

2013 2nd International Conference on Electrical, Control and Computer Engineering, Pahang, Malaysia, August 27-28, 2013

Development of Single-station Early Warning Lightning Alarm System

W.I.Ibrahim, L.N. Muhammad, S.A. Ghani
Sustainable Energy & Power Electronics Research (SuPER)
FKEE, Universiti Malaysia Pahang
26600 Pekan, Pahang.
wismail@ump.edu.my

M.R.Ghazali, M.F.M.Jusof
Instrumentation & Control Engineering (ICE)
FKEE, Universiti Malaysia Pahang
26600 Pekan, Pahang

Abstract—Lightning is one of the spectacular natural phenomena which happen on the earth. More than 2000 people are killed worldwide by lightning each year. The lightning monitoring system is important as the early warning alarm system. In this paper, lightning warning alarm system which can monitor and observe the lightning activity has been discussed. The system able to trigger the warning alarm whenever a lightning strikes at a particular area in 10 km radius from UMP Pekan, Pahang, Malaysia. The LabVIEW software was used as a data logger to measure, analyze and calculate the lightning distance. The accuracy of the system has been compared and validated by the Pekan Lightning Detection System (PLDS).

Keywords—Electromagnetics field, Electric field, Single-station, Lightning, LabVIEW, Pekan Lightning Detection System

I. INTRODUCTION

Lightning happens when two massively charged cloud is colliding in mid air. The collision releases huge amounts of energy in form of light, high volt, sound, heat, and many other more. It also produces electromagnetic field (EMF) and electrostatic field (EF). Due to its very high volt, it is very dangerous to human's life. It also can cause losses to communication equipments, power transmission line, power distributions system and more other expensive equipments. Development of a lightning warning alarm system is very important to monitor local lightning activity so that early precautions can be taken before any unexpected tragedy happen.

There are a lot of researches that related to lighting detection system had been done by researchers all over the world. The aim for their research is to monitor and get the early warning so that they can avoid or minimize the damage to the equipments that caused by lightning activity. Beside that the researches are also to increase the effectiveness and reliability of the system which is important for a good lightning detector. There are a lot of method of lightning detection. Among them are Electromagnetic Field (EMF) and Electric Field (EF) signal detection.

There are also a few of approaches for locate lightning based on observations at a single station. The techniques basically use a single VLF receiver and give a more convenient way to locate the sources. The system [1] usually a combine the direction finding with estimation of the distance to the source strikes.

The simplest method to estimate the distance is based on the amplitude of lightning signal, which assumes that all lightning are the same and its amplitude decreases with distance [2]. The distance of the lightning strike also can be determined by the ratio [3] of the magnetics field to the electric field signals.

Wave line theory in waveguide is another method to get the distance of lightning. Full wave analysis [4] was used in order to examine the applicability of location technique. The technique was based on the observation of a couple of sequential pulses appearing on the waveform of each VLF sferics. From that, the information of both the direction and the distance can be determined.

Wave impedance [5] technique was used to measure the distance of nearby thunderstorm discharges in the Earth ionosphere. Wave interval is examined based on differences in the frequency dependencies of the static induction and components of electromagnetic field. Radio-wave reflection from waveguide walls is described by sferics of imaginary sources of decreasing amplitude, which allows estimation of the near zone side which range about 50km.

The time-to-thunder [6] method was used to determine the lightning strike distance. The method used the combinations of broadband VHF antenna and microphone to form single-station detection. The broadband antenna was used to detect the electric field signals and the microphone was used to detect the acoustic signals. Based on the different time delay between both signals, the lightning strike can be calculated.

In this paper, the ratio of EMF to EF method was used to determine the lightning strike distance. The method used the combinations of wire antenna and magnetics loop antenna to

form a single-station lightning monitoring system. In the method, the wire antenna was used to detect the EF signals and the magnetics loop antenna was used to detect the EMF signals. Based on the both signals, the distance of lightning stroke can be calculated.

II. METHODOLOGY

The lightning monitoring system has three main parts, which is hardware part, interfacing part and the software part. The location of this system was installed are at Faculty Electrical and Electronics Engineering, Pekan campus, Universiti Malaysia Pahang. The complete process flow of this system is showed in Figure 1.

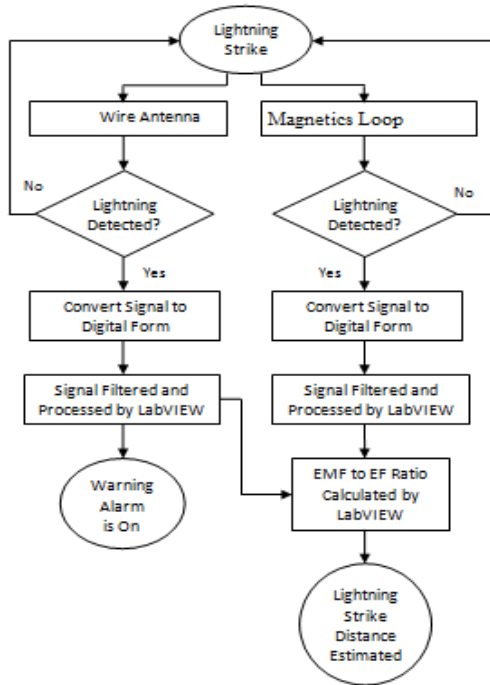

Figure 1. Process flow of the system

A. Hardware

The hardware that has been used in the system is a wire antenna for EF detection. The antenna consists of copper wire receiver, amplifier circuit, PVC protection housing and connection coaxial cable. The main function of this hardware part is to detect and amplify lightning's Electromagnetic Field (EF) signal from the lightning strikes. Figure 2 showed the wire antenna has been installed at Block 1, Faculty of Electrical & Electronics UMP, Pekan.



Figure 2. Wire Antenna to detect EF signals

An amplifier circuit was used in this system to amplify the EF signal showed in Fig 3. This amplifier circuit also consist element of protection which can protect the system in case of high voltage or high current pass through the receiver system.

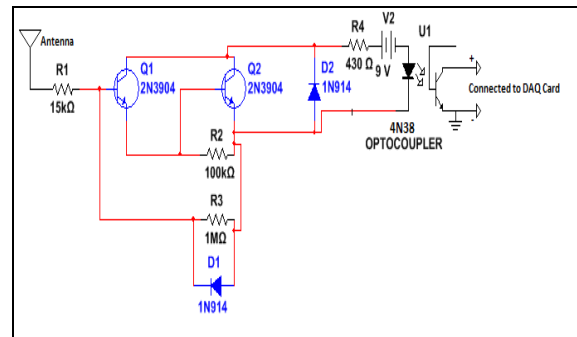

Figure 3. Amplifier circuit diagram

Magnetics loop antenna was used to detect the electromagnetic fields (EMF) radiates when lightning strike. The antenna was placed on FKEE's building and connected to 40m coaxial cables. Both antennas have same length and specification of coaxial cables. Figure 4 showed the magnetics loop antenna installed at the site.

The Mitti-75Ω coaxial cable was used to connect the wire antenna to the DAQ- NI 6212-USB. This type of cable have relatively low resistance and suitable for transferring high speed signal without huge losses.



Figure 4. Magnetics antenna to detect EMF

The prototype of warning alarm system consists of 6-15V dc buzzer and indicator LED. The buzzer will be triggered for particular period of time depends to the EMF and EF intensity in that area. Fig 5. showed the prototype of warning alarm system that has been used.



Figure 5. Prototype of warning alarm system

B. Software

The graphical user interface (GUI) has been developed using National Instrument LabVIEW 2011 software. The GUI was developed to monitor the lightning activity at 25 km radius from UMP Pekan. The signals will be filtered and analyze by the software programming. Time of detection, EMF and EF waveform signal, filter signals and estimated distance has been displayed the front panel of LabVIEW programming. Fig.6 showed the front panel of LabVIEW programming

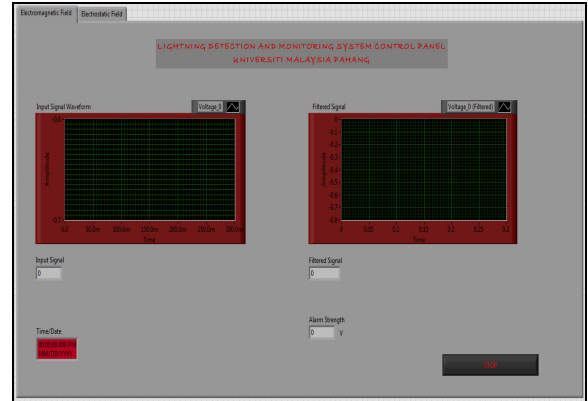

Figure 6. Offline labVIEW GUI program

III. SINGLE-STATION DETECTION

A. Estimation of Distance

Electric and magnetic fields generated by the lightning produced a signal having amplitude corresponding to the distance of lightning stroke. It has been determine that the distance of the lightning stroke within approximately 30 miles is directly proportional to the ratio of magnetics field to the electric field generated by the lightning stroke [10]. Equation (1) shows the formula to estimate the distance of the lightning stroke from the sensor.

$$Dis \tan ce = \frac{\sqrt{H_{\omega}}}{E_{\omega}} \quad (1)$$

Where H_{ω} is a horizontal magnetic fields and E_{ω} is vertical electric fields.

However, each magnetics loop antennas produces a voltage V_m which depends on the angle, θ of the loop plane to the signal source, the frequency of observation, the loop area F , and the number of the turns n , according to the following formula:

$$V_m = \mu \cdot H \cdot \omega \cdot F \cdot n \cdot \cos \theta \quad (2)$$

B. Estimation of Direction

From a pair of loop antenna that place perpendicular to each other, the direction of lightning strike can be estimated. The angle is determined by using this formula:

$$Direction = \tan^{-1} \frac{H_{NS}}{H_{EW}} \quad (3)$$

Note that, the negative angle means the direction anti-clockwise from east direction. Figure 7 shows a pair of loop antenna schematic to find the direction of lightning strike.

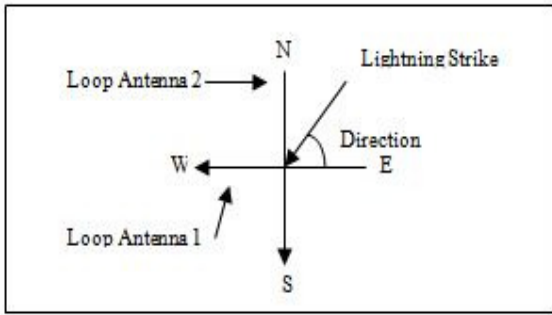

Figure7. A pair of loop antenna

IV. RESULT

This section describes the experimental results of lightning measurement using the ratio of EMF and EF. It includes results analysis and output that captured by the GUI LabVIEW software. In this project, the actual lightning strike distance has been compared to Pekan Lightning Detection System (PLDS).

The data of lightning strike detection was observed during thunderstorm days on 4th May 2012 at 8.15PM until 9.30PM. This data was captured by the system and the entire signal that observed in GUI was recorded. The data consist of the time of during lightning strike, EMF and EF amplitude. The data record as shown in Table 1.

Fig.8 shows the EF captured by the system for the negative return stroke occurred at 8.39pm on 4th May 2012. The positive value of EF indicates negative cloud to ground stroke.

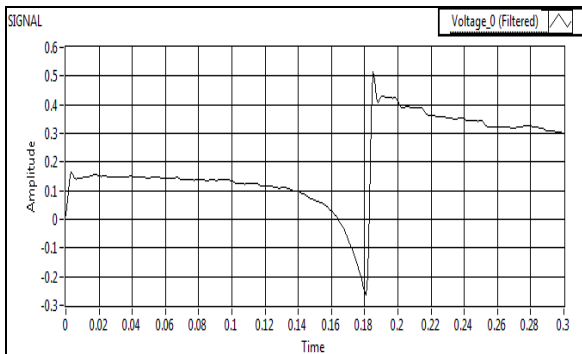

Figure8. EF negative first stroke discharge on 4th May 2012 at 8.39 pm

Fig.9 shows the EMF measured by the system for the multiple negative return strokes occurred on 4th May 2012 at 9.03 pm.

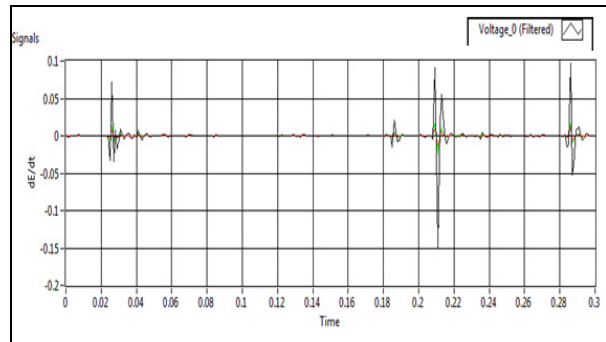

Figure9. EMF measured for return stroke occurred at 9.03 pm on 4th May 2012.

The strength of EMF appears usually very small value of V_m compared to EF signals. A wire antenna is utilized to sense the EF produced by lightning stroke is a higher impedance device. That why the wire antenna produces higher voltage (V_m) than EMF antenna. The voltage produced by the loop antenna (EMF) signals appears usually as a very low impedance source because of technical difficulties to construct high loop inductances. That why the strength of EMF (V_m) is smaller compared to EF.

Several data had been captured throughout the testing process. Table I showed the time of lightning occurrences, measurement of EF and EMF and calculated distance. The distance to the lightning stroke within approximately 30 miles is directly proportional to the ratio of EMF to EF generated by the lightning stroke. The distance can be calculated using equation (1). The shortest distance was recorded at 8.44.18 PM which is 0.19 km from the sensor to the lightning stroke. The strength of EF is equal to 4.2 V/cm and 0.65 V/cm for EMF.

TABLE I. LIGHTNING EF, EMF AND DISTANCE OF STRIKE ON 4TH MAY 2012.

Time (PM)	EF Amplitude (V_m)	EMF Amplitude (V_m)	Estimated Distance (KM)
8.39.10	0.5	0.15	0.77
8.43.22	1.0	0.25	0.5
8.44.18	4.2	0.65	0.19
8.45.39	1.2	0.32	0.47
8.55.31	-2.6	0.45	0.25
8.56.44	0.5	0.13	0.72
9.02.12	0.55	0.18	0.77
9.02.25	-0.27	0.1	1.17
9.03.39	0.2	0.08	1.41
9.26.14	-0.4	0.15	0.97

Table II showed the detection comparison between the single station detection with Pekan Lightning Detection System (PLDS). The sensor was located on coordinate 3° 32' 0" North, 103° 28' 0" East which is Block 1, FKEE, Universiti Malaysia Pahang, Pekan. The system consists of three major parts, including the combination of magnetic direction and time -of- arrival finder antenna, receiver and lightning location information analysis and GUI system.

TABLE II. DETECTION COMPARISON WITH PLDS

Time (PM)	No. of Lightning Detected	
	Single Station Detection	PLDS
8.39	1	3
8.43	1	2
8.44	1	3
8.45	1	2
8.55	1	3
8.56	1	3
9.02	2	5
9.03	1	2
9.26	1	2

Data from table II shows the comparison of the lightning strikes recorded by PLDS and single station detection. Five strikes were recorded by PLDS at 9.02 pm and 2 strikes were recorded by single station at same time. As a whole, the total of lightning strikes detected by PLDS is 25 strikes and 10 lightning strikes were detected by single station. The detection of PLDS is very high because PLDS used Magnetic Direction Finder and Time -of- Arrival method of detection.

Every time the lightning stroke occurred, the alarm automatically triggered. The triggering period is depends on the intensity of EMF and EF .The loudness of the alarm is depends on the strength of the lightning signal detected.

V. CONCLUSION

A wire antenna and magnetics loop antenna for EF and EMF detection respectively has successfully developed and

installed at FKEE UMP, Pekan. The system is able to detect EF and EMF signals during thunderstorm days. The data such as date, time and distance of the lightning event has been displayed on GUI. The detection range for single station is up to 10 km radius based on data collection during March 2012 to May 2012. The detection accuracy almost 80 percent and has been validated by Pekan Lightning Detection System (PLDS). However the percent of detection accuracy has been decreased to 40 percent if the range detection increases up to 20 km radius.

ACKNOWLEDGMENT

The authors wish to thank to Universiti Malaysia Pahang that made this research collaboration possible. The project has been supported by RDU100385

REFERENCES

- [1] Lothar H. Runhke, Boulder, Colo. "Determining Distance to Lightning Strokes from a Single Station. United Stated Patents 3715660, Feb.6, 1963
- [2] V. A. Rafalsky, A. P. Nickolaenko, A. V. Shrets, and M. Hoyakawa, "Location of Lightning Discharges from a Single Station", Journal of Geophysical Research, Vol. 100, pg 20, 829-20, 838, Oct 20, 1995.
- [3] V. Ramachandran, J. N. Prakash, A. Deo and S. Kumar, Lightning stroke distance estimation from single station observation and validation with WWLLN data, Ann. Geophys, 25, 1509-1517, 2007.
- [4] W. Itaro, I. Nagaro, S. Yagatani and M. Ozoki, "Lightning Location with Single-Station of VLF Sferics", 2ndKarazawa Workshop, WAVE 11 pg. 22, March 2006
- [5] M. A. Karol and A. P. Nikolaenko, "Measurement of Distances to Nearby Thunderstorm Discharges", Radio Physics & Quantum Electronics, Vol. 36, Nov 3-4, 1993.
- [6] W.I.Ibrahim, Zulkurnain Abdul Malek, "Time to Thunder Mmethod of Lightning Detection" 2010 International IEEE Conference on Power and Energy, (PeCON).
- [7] Noradlina Abdullah, MohdPauziYahya, Dr. NadiyahSalwiHudi, "Implementation and Use of Lightning Detection Network in Malaysia", TNB Research Sdn. Bhd., PECon Dec 2008.
- [8] MohdPauziYahya, "Lightning Phenomenon in Malaysia", TNB Research Sdn. Bhd., ARSEPE Jan 2007.
- [9] Zhang Zhi-Gang, Guofu-Yan, "Design and Implementation of Monitoring and Early Warning System in Lightning Protection Device", TIANJIN Institute of Urban Construction.
- [10] Wu Yanjie, Fan Changyuan, Li Yiding, "Design of Lightning Location System Based on Photon and Infrasound Detection", Chengdu University of Information Technology, ICEMI' 2007.