

International Journal of the Physical Sciences Vol. 6(13), pp. 3082 -3090, 4 July, 2011

Available online at <http://www.academicjournals.org/IJPS>

ISSN 1992 - 1950 ©2011 Academic Journals

Full Length Research Paper

Particle swarm optimisation prediction model for surface roughness

M. M. Noor^{1,2}, K. Kadirgama^{1,2} and M. M. Rahman^{1,2*}

¹Automotive Engineering Centre, Universiti Malaysia Pahang, 26600 Pekan, Pahang, Malaysia.

²Department of Mechanical Engineering, Universiti Malaysia Pahang, 26600 Pekan, Pahang, Malaysia.

Accepted 25 May, 2011

Acrylic sheet is a crystal clear (with transparency equal to optical glass), lightweight material having outstanding weather ability, high impact resistance, good chemical resistance, and excellent thermoformability and machinability. This paper develops the artificial intelligent model using particle swarm optimization (PSO) to predict the optimum surface roughness when cutting acrylic sheets with laser beam cutting (LBC). Response surface method (RSM) was used to minimize the number of experiments. The effect of cutting speed, material thickness, gap of tip and power towards surface roughness were investigated. It was found that the surface roughness is significantly affected by the tip distance followed by the power requirement, cutting speed and material thickness. Surface roughness becomes larger when using low power, tip distance and material thickness. Combination of low cutting speed, high power, tip distance and material distance produce fine surface roughness. Some defects were found in microstructure such as burning, melting and wavy surface. The optimized parameters by PSO are cutting speed (2600 pulse/s), tip distance (9.70 mm), power (95%) and material thickness (9 mm) which produce roughness around 0.0129 μm .

Key words: Laser beam, particle swarm optimization, surface roughness, acrylic sheet.

INTRODUCTION

Laser light differs from ordinary light because it has the photons of same frequency, wavelength and phase. Thus, unlike ordinary light, laser beams are highly directional, have high power density and better focusing characteristics (Chryssoulouris, 1991; Dubey and Yadava, 2008). These unique characteristics of laser beam are useful in processing of materials. The laser beams are widely used for machining and other manufacturing processes such as cutting, drilling, micromachining, marking, welding, sintering and heat treatment. Laser beam machining (LBM) is a thermal energy based

advanced machining process in which the material is removed by melting, vaporization and chemical degradation. When a high energy density laser beam is focused on work surface, the thermal energy is absorbed which heats and transforms the work volume into a molten, vaporized and chemically changed state that can be easily removed by flow of high pressure assist gas. LBM can be applied to a wide range of materials such as metals and non-metals. Laser surface texturing may be an ideal technology for applications in mechanical face seal, as well as in various components in engine such as piston ring and cylinder and thrust bearings, involving creation of an array of micro dimples or channels artificially distributed on the mating surface with a pulsed laser beam (Du et al., 2005; Etsion and Halperin, 2003).

*Corresponding author. E-mail: mustafizur@ump.edu.my

The most widely used lasers for sheet cutting are continuous wave (CW), CO₂ and pulsed Nd:YAG (Schreck and Zum Gahr, 2005). Pulsed Nd:YAG laser cutting becomes an excellent cutting process because of high laser beam intensity, low mean beam power, good focusing characteristics, and narrow heat affected zone (HAZ) (Luxon and Parker, 1985; Steen, 1991). Lei et al. (2001) have found that the laser-assisted turning (LAT) of silicon nitride ceramics economically reduces the surface roughness and tool wear in comparison to only conventional turning process. The study reveals that low pulse frequencies and high peak powers were found to be favourable for higher cutting speeds. Noor et al. (2010) observed that surface roughness is affected significantly by the power requirement, followed by tip distance and cutting speed when laser beam cutting on acrylic sheets. This project presents the experimental investigations of using partial swarm optimisation and acrylic sheets in order to predict the significant factors and their effects on quality characteristics for better cutting performance and showing the effect of relationship between process variables and performance characteristics.

MATERIALS AND METHODS

Response surface method

Response surface method (RSM) is a collection of statistical and mathematical methods that are useful for the modelling and optimization of the engineering problems. In this technique, the main objective is to optimize the responses that are influenced by various parameters. RSM also quantifies the relationship between the controllable parameters and the obtained response. In modelling of the manufacturing processes using RSM, the sufficient data is collected through designed experimentation. In general, a second order regression model is developed because first order models often give lack-off fit (Montgomery, 1997). The study uses the Box-Behnken design in the optimization of experiments using RSM to understand the effect of important parameters. Box-Behnken design is normally used when performing non-sequential experiments. That is, performing the experiment only once. These designs allow efficient estimation of the first and second –order coefficients. Because Box-Behnken design has fewer design points, they are less expensive to run than central composite designs with the same number of factors. Box-Behnken design do not have axial points, thus we can be sure that all design points fall within the safe operating. Box-Behnken design also ensures that all factors are never set at their high levels simultaneously (Draper and Smith, 1981; Box and Draper, 1987; Box and Behnker, 1960).

Partial swarm optimisation

PSO has many advantages over other evolutionary computation techniques (for example, genetic algorithms (GAs)) such as simpler implementation, faster convergence rate and fewer parameters to adjust (Kennedy et al., 2001; Poli, 2007). The popularity of PSO is growing with applications in diverse fields of engineering, biomedical and social sciences (Poli and Stephens, 2004). Some of the recent applications of PSO in engineering include machinery condition

monitoring and diagnostics (Li and Dam, 2003). PSO has been seen has the most potential application, areas are pattern recognition, biological system modeling, robotic applications, simulations and identification. PSO is a population-based stochastic optimization technique developed by Kennedy and Eberhart (1997), inspired by social behaviour of bird flocking or fish schooling. In the PSO algorithm, there is a swarm of particles moving in an n -dimensional problem space, where each particle represents a potential solution. In simple terms, particles are ‘flown’ through a multidimensional search space, where the position of each particle is adjusted according to its own experience and that of its neighbours (Armand et al., 2007).

PSO algorithm is similar to that of the evolutionary computation techniques in which a population of potential solutions to the optimal problem under consideration is used to probe the search space. Each potential solution is also assigned a randomized velocity, and the potential solutions, called particles, correspond to individuals. Each particle in PSO flies in the D -dimensional problem space with a velocity dynamically adjusted according to the flying experiences of its individuals and their colleagues. The location of the i th particle is represented as $X_i=[x_{i1}, x_{i2}, \dots, x_{iD}]$, where $x_{id} \in [l_d, u_d]$, $d \in [1, D]$, l_d, u_d are the lower and upper bounds for the d^{th} dimension, respectively. The best previous position (which gives the best fitness value) of the i^{th} particle is recorded and represented as $P_i=[p_{i1}, p_{i2}, \dots, p_{iD}]$, which is also called P_{best} . The index of the best particle among all the particles in the population is represented by the symbol g . The location P_g is also denoted by g_{best} . The velocity of the i^{th} particle is represented by $V_i=[v_{i1}, v_{i2}, \dots, v_{iD}]$ and is clamped to a maximum velocity $V_{max}=[V_{max1}, V_{max2}, \dots, V_{maxD}]$, which is specified by the user. The particle swarm optimization concept consists of, at each time step, regulating the velocity and location of each particle toward its P_{best} and g_{best} locations according to the Equations (1) and (2), respectively (Liu and He, 2005).

$$v_{id}^{n+1} = wv_{id}^n + c_1 r_1^n (p_{id}^n - x_{id}^n) + c_2 r_2^n (p_{gd}^n - x_{id}^n) \quad (1)$$

$$x_{id}^{n+1} = x_{id}^n + v_{id}^{n+1} \quad (2)$$

The PSO outputs have been termed as one output node representing the state variable (tool life) as shown in Figure 1. The experimental results are used for the optimisation of the tool life model using the PSO. The codes for the PSO are written in Matlab 7.0 which follows the logic of the pseudocode shown in Figure 2. According to Zhou et al. (2005), particle swarm optimization (PSO) technique performs better than back propagation (BP) algorithms when the diameter error in a boring machining is predicted. To overcome the stagnation in searching a globally optimal solution, a PSO method with nonlinear time-varying evolution (PSO-NTVE) is proposed to approach the optimal solution closely. When determining the parameters in the proposed method, matrix experiments with an orthogonal array are utilized, in which a minimal number of experiments would have an effect that approximates the full factorial experiments (Koa et al., 2007). Changa and Kob (2008) proposed a method with nonlinear time-varying evolution based on neural network (PSO-NTVENN) to design large-scale passive harmonic filters (PHF) under abundant harmonic current sources. The goal is to minimize the cost of the filters, the filters loss, and the total harmonic distortion of currents and voltages at each bus, simultaneously. The performance of PSO for function optimization in noisy environment is investigated, and an effective hybrid PSO approach named PSOHT is proposed by Pan et al. (2006).

Experimental setup

The experiment was performed on a 30 W pulsed Nd:YAG laser beam

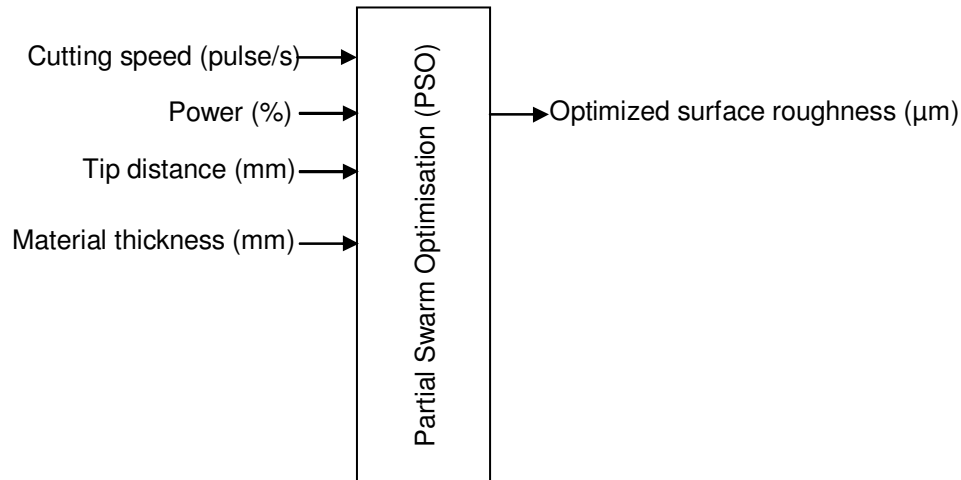

Figure 1. PSO for paddle cantilever.

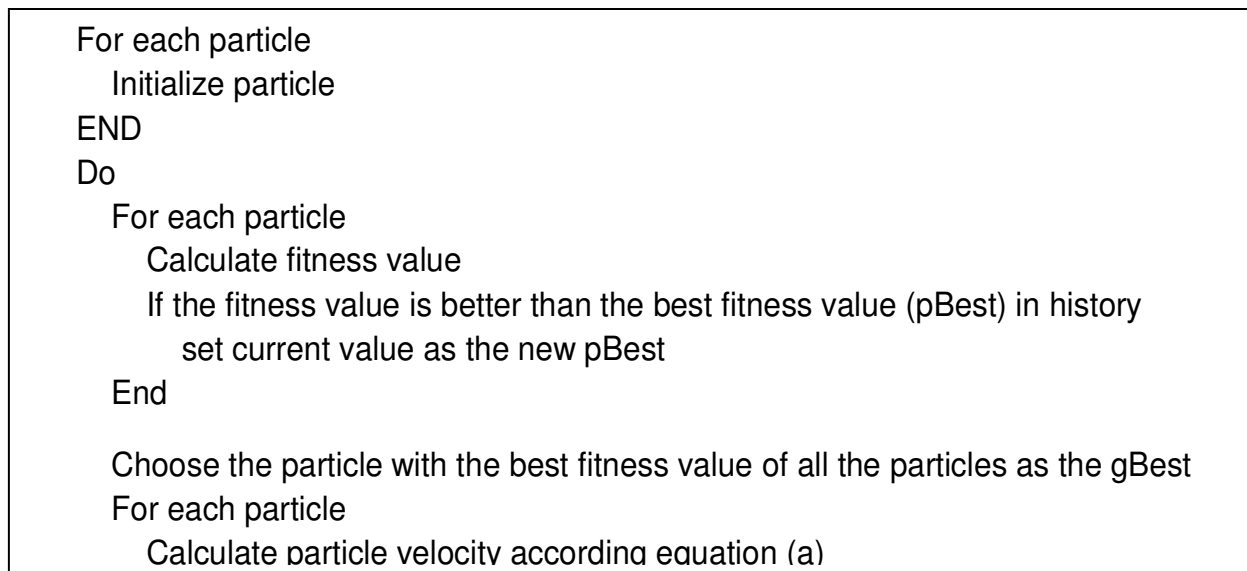

Figure 2. A pseudo-code for PSO.

system with CNC worktable. The oxygen is used as an assist gas. The variable process parameters taken are: beam power, cutting speed, materials thickness and tip distance. Focal length of the lens used is 50 mm, nozzle diameter 1.0 mm and nozzle tip distance 1.0 mm, were kept constant throughout the experiments. The 27 experiments were carried out using the laser machine, which is shown in Figure 3. Acrylic sheet of thickness 3, 6 and 9 mm was taken as specimen. The specimen was cut into 30 mm width and 40 mm long as shown in Figure 4. Acrylic sheet was cut into rectangular size to measure the surface roughness. Four sides were measured to get the average roughness. Surface roughness tester Perthometer S2 was used for measurement of roughness. The material properties of the workpiece are listed in Table 1. After the preliminary investigation, the suitable levels of the factors are used in the statistical software

to deduce the design parameters for acrylic sheets, which is also listed in Table 2. The lower and higher speed values were selected of 2600 and 3000 pulse/s, respectively. The higher and lower value of power requirement of 90 and 95% are considered. The range of tip distance is 3 to 9 mm. The design of experiment is shown in Table 3.

RESULTS AND DISCUSSION

From the experiments, it is noticed that the response surface roughness is affected by the tip distance followed by the power requirement, cutting speed and material

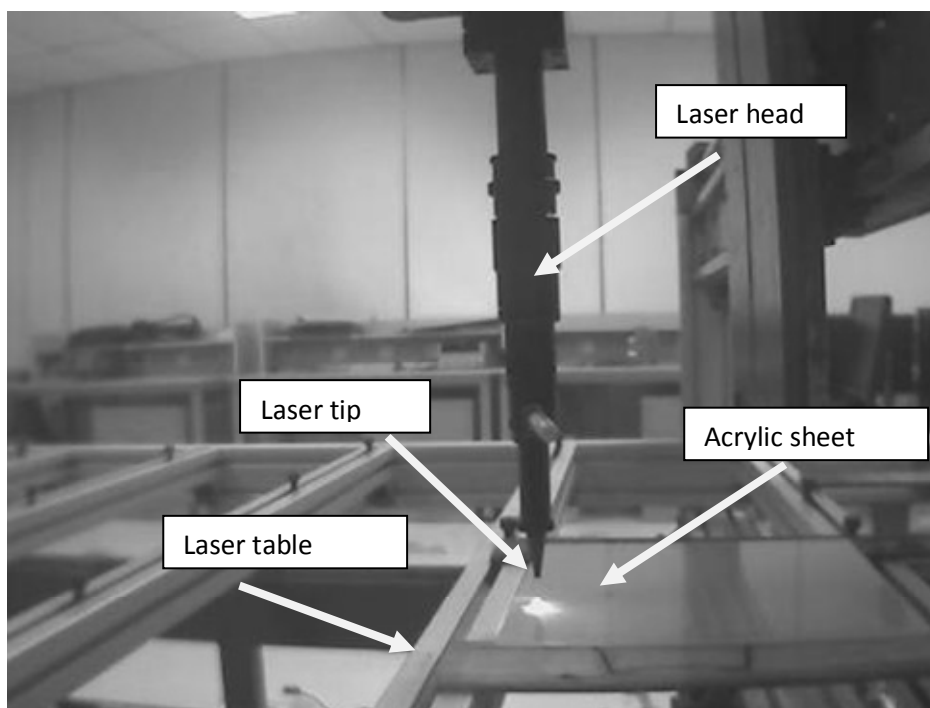

Figure 3. Laser machine.

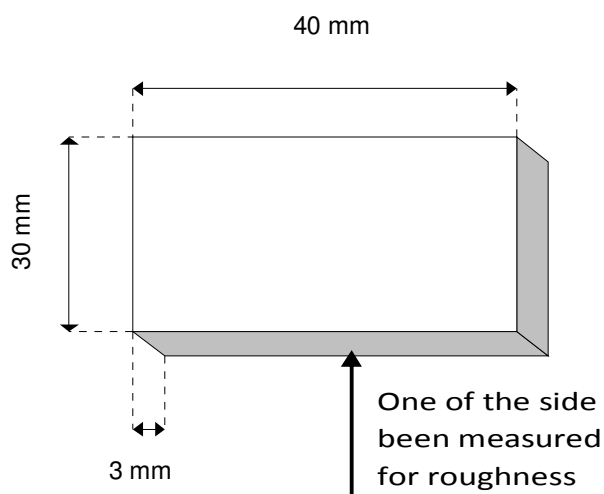

Figure 4. Dimension of the specimen.

Table 1. Material properties of specimen.

Property	Value	Unit
Density	1170	kg/m ³
Yield tensile strength	52.1	MPa
Processing temperature	156	°C
Modulus of elasticity	2.31	GPa

Table 2. Level of design variables.

Design variable	Coding of levels		
	Lowest	Middle	Highest
Power requirement (%)	90	92.5	95
Cutting speed (pulse/s)	2600	2800	3000
Tip distance (mm)	9.5	9.5	9.7
Material Thickness (mm)	3	6	9

Table 3. Design of experiment.

No.	Material thickness (mm)	Gap (mm)	Cutting speed (pulse/s)	Laser power (%)
1	3	9.5	2800	95
2	6	9.3	2800	95
3	6	9.3	2600	90
4	9	9.5	3000	90
5	9	9.5	2800	92.5
6	6	9.5	3000	92.5
7	6	9.3	3000	90
8	3	9.3	2800	90
9	6	9.5	2600	92.5
10	6	9.7	3000	90
11	3	9.5	2600	90
12	6	9.5	2600	95
13	6	9.5	3000	95
14	9	9.5	2600	90
15	9	9.7	2800	90
16	9	9.5	2800	95
17	6	9.7	2600	90
18	6	9.5	2800	90
19	6	9.3	2800	92.5
20	9	9.3	2800	90
21	3	9.5	3000	90
22	6	9.7	2800	92.5
23	6	9.7	2800	95
24	3	9.5	2800	92.5
25	3	9.7	2800	90
26	6	9.5	2800	90
27	6	9.5	2800	90

thickness. On other hand, high cutting speed produces a very smooth surface. Similar trend was observed by Choudhury and Shirley (2010) and Ciazzo et al. (2005). According to Choudhury and Shirley (2010), surface roughness represents the quality of cut surface and its value decreases with increasing speed, power and compressed air pressure. The effect of cutting speed and compressed air pressure are more pronounced than the effect of laser power on surface finish. Usually the value

of R_a diminishes as the cutting speed increases and this is true for conventional metal cutting. Meanwhile, Ciazzo et al. (2005) found that all of the three materials generally follow the rule (which the results of experiments on ferrous and nonferrous metals have already amply validated) according to which the value of R_a diminishes as cutting speed increases. Moreover, they all show R_a values which are much lower if compared, for instance, with a typical construction steel. Ghany and

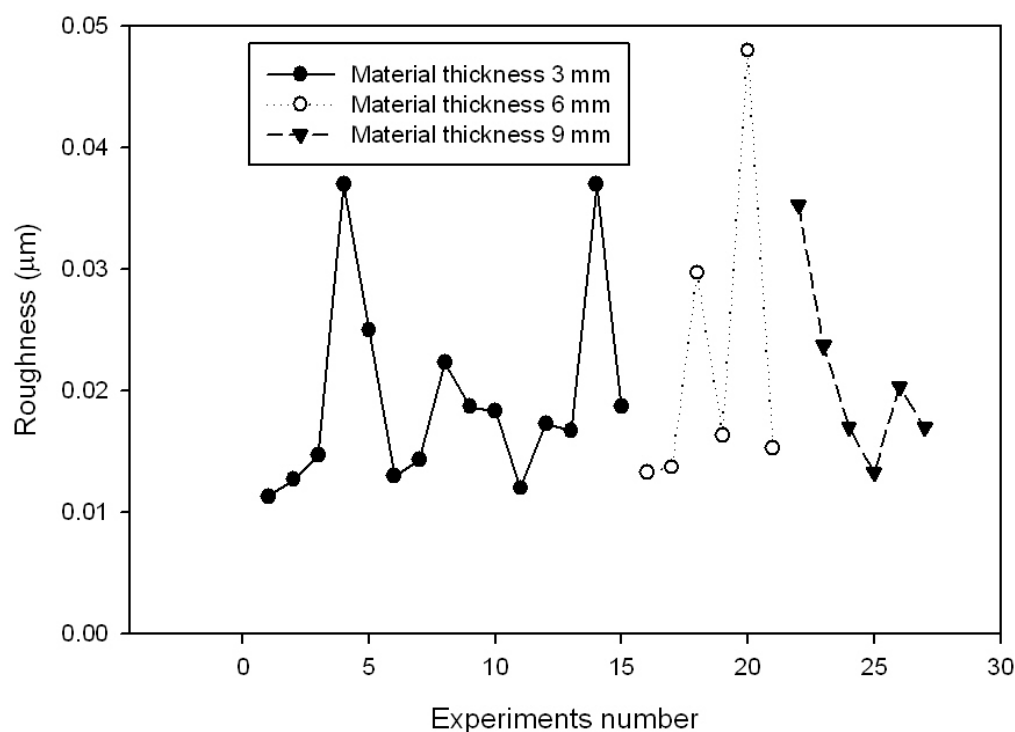

Figure 5. Effect of material thickness towards roughness.

Newishy (2005) found that surface roughness decreased as the laser cutting speed increased, and the laser power and gas pressure both decreased. The present finding of improvement in surface, finished with increasing laser power agrees with the findings of Choudhury and Shirley (2010) but not with Ghany and Newishy (2005). Rajaram et al. (2003) observed that laser power and cutting speed have a significant effect on surface roughness and striation. Ciazzo et al. (2005) found that for polypropylene, if the thickness is doubled, power is kept almost constant, and almost half the speed, the value of R_a doubles, rising from ≈ 0.7 to $1.4 \mu\text{m}$. These finding is supported with current finding, when material thickness increases from 3 to 6 mm where the roughness range from 0.012 to $0.04 \mu\text{m}$ (thickness 3 mm) rising to $0.048 \mu\text{m}$. Meanwhile, this finding is inverse when the material thickness is increase to 9 mm, where the roughness are ranged from 0.012 to $0.035 \mu\text{m}$ as shown in Figure 5. These phenomenon is supported by Ciazzo et al. (2005) when laser cutting on polycarbonate, if both thickness and power are doubled, at cutting speeds very close to the other, the R_a values observed do not differ very much (from 2.02 to $2.08 \mu\text{m}$), and fall within the range ≈ 2 to $3 \mu\text{m}$. Figure 6 shows the surface roughness condition for the experiment with high power and cutting speed. It is clearly seen that the melting and burning occurs.

Figure 7 shows the surface texture for the surface

roughness of $0.0250 \mu\text{m}$. The surface texture is without melting surface compare with Figure 6; however, it is quite wavy at the surface. It's very important to verify the surface texture since the defect at the microstructure cause the materials pathetic and less strength (Stephenson and Agapiou, 1997). Surface plot for cutting parameters and surface roughness are shown in Figure 8. The relationship between surface roughnesses with cutting parameters can be seen. In Figure 8a, it was observed that low tip distance (9.30 mm) and low power (90%) produce roughness around ($0.028 \mu\text{m}$). The combination of low cutting speed (2650 pulse/s) and low power (91%) produce rough surface ($0.026 \mu\text{m}$) as shown in Figure 8b. The situation quite different with combination of high cutting speed (2950 pulse/s) and low tip distance (9.30 mm) produce bigger roughness values ($0.04 \mu\text{m}$) as shown in Figure 8c.

Test validation

The optimized surface roughness model is tested with experimental result. The predicted surface roughness using optimized roughness model is compared with the measured roughness and their results are reported in Table 4. The validation experiment is performed in the same machining environment as the training experiment.

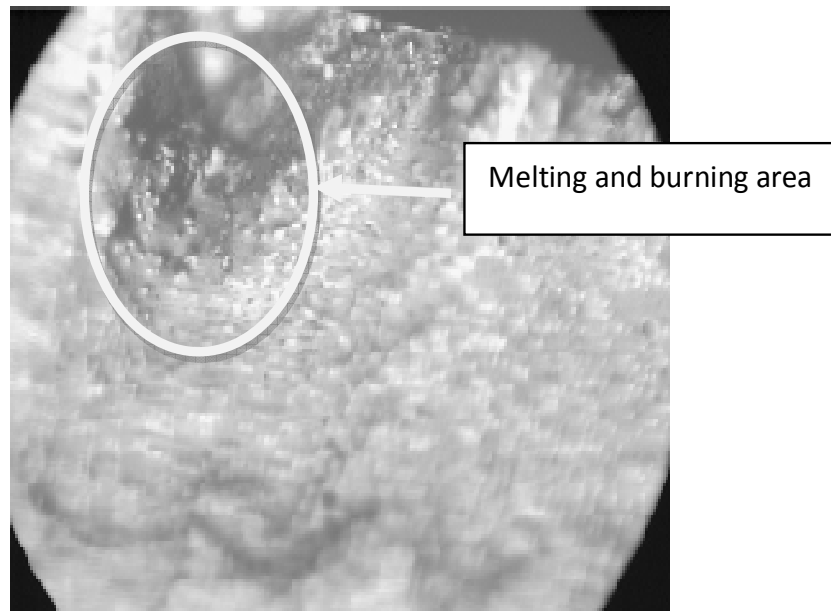

Figure 6. Microscope picture for roughness at condition materials thickness 6 mm, tip distance 9.5 mm, cutting speed 3000 pulse/s and power 95%.



Figure 7. Microscope picture for roughness at condition material thickness 6 mm, tip distance 9.5 mm, cutting speed 2600 pulse/s and power 92.5%.

The percentage of error of roughness obtained by optimized roughness model is about 3.73% which is within the acceptable level. This error also agrees with Zhou et al. (2005) results. According to Zhou et al.

(2005), the networks for diameter error prediction trained by the PSO algorithm or by the BP algorithm both improve the precision of the boring machining, but the neural networks trained by the PSO algorithm perform

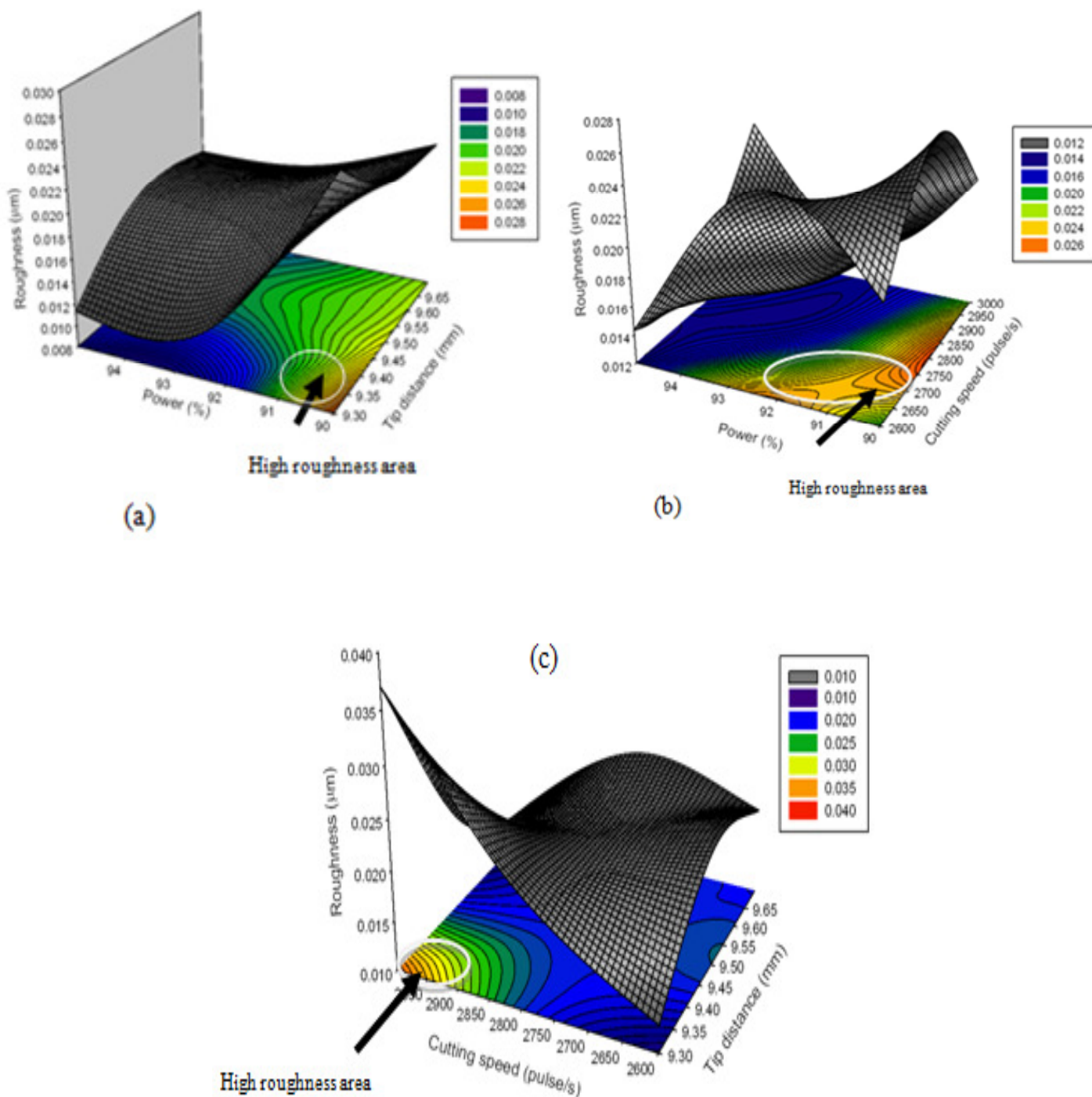

Figure 8. (a) Surface roughness at power and tip distance plane; (b) Surface roughness at power and cutting speed plane; (c) Surface roughness at cutting speed and tip distance plane.

better than those trained by the BP algorithm. It is expected that the PSO algorithm will become more popular as an optimization tool in many fields in the future.

CONCLUSIONS

According to the results obtained in this study, the following conclusions could be drawn as follows:

Table 4. Comparison between optimization and experimental results.

Cutting speed (pulse/s)	Tip distance (mm)	Power (%)	Material thickness (mm)	Surface roughness (μm)		Deviation (%)
				Expt.	Predicted	
2600	9.70	95	9	0.0132		2.27
2600	9.70	95	9	0.0135	0.0129	4.44
2600	9.70	95	9	0.0135		4.44
				0.0134 (av.)		3.73

(1) It was found that the surface roughness is significantly affected by the tip distance followed by the power requirement, cutting speed and material thickness.

(2) Surface roughness becomes larger when using low power, tip distance and material thickness. Combination of low cutting speed, high power, tip distance and material distance produce fine surface roughness.

(3) The optimised parameters by PSO are cutting speed (2600 pulse/s), tip distance (9.70 mm), power (95%) and material thickness (9 mm) which produce roughness around (0.0129 μm). The error of roughness obtained by optimized roughness model is 0.085%.

(4) At materials thickness (6 mm), tip distance (9.5 mm), cutting speed (3000 pulse/s) and power (95%), there is a melting and burning area.

ACKNOWLEDGMENT

The authors would like to acknowledge the support of Universiti Malaysia Pahang for funding under University Grant No. RDU0903098.

REFERENCES

- Armand S, Blumenstein M, Muthukumarasamy V (2007). Off-line signature verification using an enhanced modified direction feature with single and multi-classifier approaches. *IEEE Comput. Intell. Mag.*, pp. 18–25.
- Box GEP, Behnken DW (1960). Some new three level designs for the study of quantitative variables. *Technometrics*, 2: 455–475.
- Box GEP, Draper NR (1987). *Empirical model-building and response surfaces*. John Wiley & Sons, New York.
- Ciazzo F, Curcio F, Daurelio G, Memola F, Minutolo C (2005). Laser cutting of different polymeric plastics (PE, PP and PC) by a CO₂ laser beam. *J. Mater. Process. Technol.*, 159: 279–285.
- Changa YP, Kob CN (2008). A PSO method with nonlinear time-varying evolution based on neural network for design of optimal harmonic filters. *Expert Sys. Applic.*, 36(3): 6809–6816.
- Choudhury IA, Shirley S (2010). Laser cutting of polymeric materials: An experimental investigation. *Opt. Laser Technol.*, 42: 503–508.
- Chryssolouris G (1991). *Laser Machining- Theory and Practice*. Springer, New York.
- Draper NR, Smith H (1981). *Applied Regression Analysis*. John Wiley, New York.
- Du D, He YF, Sui B, Xiong LJ, Zhang H (2005). Laser texturing of rollers by pulsed Nd:YAG laser. *J. Mater. Process. Technol.*, 161: 456–461.
- Dubey AK, Yadava V (2008). Experimental study of Nd:YAG laser beam machining– An overview. *J. Mater. Process. Technol.*, 195(1-3): 15–26.
- Etsion I, Halperin G (2003). A laser surface textured hydrostatic mechanical seal. *Seal. Tech.*, 3: 6–10.
- Ghany KA, Newishy M (2005). Cutting of 1.2 mm thick austenitic stainless steel sheet using pulsed and CWNd: YAG laser. *J. Mater. Process. Technol.*, 162: 438–47.
- Kennedy J, Eberhart R (1997). A discrete binary version of the particle swarm optimization. *Proc. IEEE Intl. Conf. System, Man, Cybern.*, 5: 4104–4108.
- Kennedy J, Eberhart R, Shi Y (2001). *Swarm Intelligence*. Morgan Kaufmann, San Francisco, USA.
- Koa CN, Changa YP, Wuc CJ (2007). An orthogonal-array-based particle swarm optimizer with nonlinear time-varying evolution. *Appl. Math. Comput.*, 191(1): 272–279.
- Lei S, Shin YC, Incropera FP (2001). Experimental investigations of thermo-mechanical characteristics in laser-assisted machining of silicon nitride ceramics. *ASME J. Manuf. Sc. Engg.*, 123: 639–646.
- Li X, Dam KH (2003). Comparing particle swarms for tracking extrema in dynamic environments. *Proc. IEEE CEC*, pp. 1772–1779.
- Liu Y, He X (2005). Modeling Identification of Power Plant Thermal Process Based on PSO Algorithm. *Am. Control Conf.*, USA.
- Luxon JT, Parker DE (1985). *Industrial Lasers and their Applications*. Prentice Hall, London.
- Montgomery DC (1997). *Design and analysis of experiments*. Wiley, New York.
- Noor MM, Kadrigama K, Rahman MM, Zuki NMNM, Rejab MRM, Muhamad KF, Julie JM (2010). Prediction Modelling of Surface Roughness for Laser Beam Cutting on Acrylic Sheets. *Adv. Mat. Res.*, 83-86: 793-800.
- Pan H, Wanga L, Liu B (2006). Particle swarm optimization for function optimization in noisy environment. *Appl. Math. Comput.*, 181(2): 908–919.
- Poli R (2007). An analysis of publications on particle swarm optimization applications. Technical Report CSM-469, Dept. Computer Science, University of Essex.
- Poli R, Stephens CR (2004). Constrained molecular dynamics as a search and optimization tool. In M. Keijzer et al. (Eds.), *Lecture notes in computer science*: 3003: 150–161.
- Rajaram N, Ahmad JS, Cheraghi SH (2003). CO₂ Laser cut quality of 4130 steel. *Int. J. Machine Tools Manuf.*, 43: 351–358.
- Schreck S, Zum Gahr KH (2005). Laser-assisted structuring of ceramic and steel surfaces for improving tribological properties. *Appl. Surf. Sci.*, 247: 616–622.
- Steen WM (1991). *Laser Material Processing*. Springer, New York.
- Stephenson DA, Agapiou JS (1997). *Metal cutting theory and practice*. Marcel Dekker, Inc.
- Zhou J, Duana ZC, Lia Y, Denga J, Yua D (2005). PSO-based neural network optimization and its utilization in a boring machine. *J. Mater. Process. Technol.*, 178(1-3):19–23.