

TESTING OF STATIC SYNCHRONOUS SERIES COMPENSATOR (SSSC) MODEL  
IN IEEE 9 BUS POWER SYSTEM NETWORK USING PSCAD AND MATLAB  
SOFTWARE

SUKMA CITRA BIN JAFIRIN

This thesis is submitted as partial fulfillment of the requirements for the award of the  
Bachelor of Electrical Engineering (Power System)

Faculty of Electrical & Electronics Engineering  
University Malaysia Pahang

November, 2010

“All the trademark and copyrights use herein are property of their respective owner. References of information from other sources are quoted accordingly; otherwise the information presented in this report is solely work of the author.”

Signature : \_\_\_\_\_

Author : SUKMA CITRA BIN JAFIRIN

Date : 30 NOVEMBER 2010

## ACKNOWLEDGMENT

First of all, I would like to give my thanks to the Almighty Allah, for giving me the strength and the ability to complete the project wholeheartedly. Without it I possibly can not finish the project in a timely manner.

Secondly, to my supervisor, Miss Lailatul Niza bt Muhammad, for being there when I needed it the most. I appreciate your guidance and critics, with hope; I could be better engineer in the future.

Not forget, my father, Jafirin bin Ja'far, my mother, Nurbaini bt Sioyok, all my siblings and Mr.Redzuan Ahmad for their continuous support and encouragement words together with understanding that have pushed me this far.

Lastly, to all the peoples that have whether directly or indirectly involved and contributed for the realisation of this project. Friends, librarians, I appreciate your help and involvement.

**LIST OF SYMBOLS AND ABBREVIATIONS**

$\delta$	-	Power angle
AC	-	Alternating Current
DC	-	Direct Current
FACTS	-	Flexible AC Transmission System
PSCAD	-	Power System Computer-Aided Design
p.u.	-	Per Unit
PSCAD	-	Power System CAD
SSSC	-	Static Synchronous Series Compensator
STATCOM	-	Static Synchronous Compensator
SVC	-	Static VAR Compensator
TCSC	-	Thyristor-Controlled Series Capacitor
TCPAR	-	Thyristor Controlled Phase Angle Regulator.
UPFC	-	Unified Power Flow Controller
V	-	Voltage
VAR	-	Reactive Power
X	-	Line Reactance

**LIST OF FIGURES**

<b>List of Figures</b>	<b>TITLE</b>	<b>PAGE</b>
1.1	PSM1 Schedule	4
1.2	PSM2 Schedule	5
2.1	Master Library of PSCAD	7
2.2	Simplified Diagram of SSSC	14
2.3	Line Diagram of SSSC	15
2.4	Control Structure of SSSC	16
2.5	Valve for a voltage-sourced converter	20
2.6	Voltage-sourced converter concept	21
3.1	Flow Chart of Methodology	25
3.2	IEEE 9 Buses Power System	26
3.3	6-pulse VSC Configuration	28
3.4	6-pulse VSC Gate Pulse Pattern	29
3.5	Control of SSSC	32
4.1	9-Bus Test System without SSSC	37
4.2	Power Flow command in Marlab	39
4.3	Total Line Losses	42
4.4	Percentage of Active Power ,P, Transfer	44
4.5	Injection SSSC	46

## ABSTRACT

Power system capability can be increased by the use of Flexible AC Transmission System devices (FACTS) in transmission systems experiencing high power flows. This thesis presents an analysis of one of these devices, namely, a Static Synchronous Series Compensator (SSSC). Voltage Source Converter (VSC) based FACTS is the most recent approach in FACTS technology. The SSSC is the key series compensation devices that open up new opportunities to control the power on transmission systems in order to enhance their utilization, increase power transfer capability and to improve voltage profile. In order to perform an investigation, an exact model of a 6-pulse GTO converter, is used as the basic building block of SSSC. Then by using a 9-bus test system the effects of SSSC on voltage stability in power systems are examined using MATLAB and PSCAD software. The optimal location of this controller is determined by analyze the lowest bus voltage profile. The 9-bus system parameters such as line voltage, line current, reactive power,  $Q$ , and real power,  $P$ , transmissions are observed when the SSSC is applied to the system.

## ABSTRAK

Sumber Tegangan Converter (STC) berdasarkan Flexible AC Transmission Systems (FACTS) adalah pendekatan yang paling terkini dalam teknologi FACTS. The statik Synchronous Seri Compensator (SSSC) adalah serangkaian peranti pampasan kunci yang membuka peluang baru untuk mengawal kuasa pada sistem penghantaran dalam rangka meningkatkan penggunaan mereka, meningkatkan daya kemampuan pemindahan dan untuk meningkatkan profil voltan. Dalam rangka melakukan penyelidikan, sebuah model yang tepat dari sebuah konverter GTO 6-pulsa, digunakan sebagai blok bangunan dasar dari SSSC. Kemudian dengan menggunakan sistem ujian 9-bas kesan SSSC terhadap kestabilan voltan dalam sistem kekuasaan diperiksa menggunakan MATLAB dan software PSCAD. Lokasi yang optimum kawalan ini ditentukan dengan menganalisis profil bus voltan yang paling rendah. Parameter sistem 9-bas seperti voltan baris, arus baris, kuasa reaktif,  $Q$ , dan kuasa aktif,  $P$ , penghantaran diamati ketika SSSC diterapkan kepada sistem.

## TABLE OF CONTENTS

CHAPTER	TITLE	PAGE
	<b>DECLARATION</b>	<b>ii</b>
	<b>DEDICATION</b>	<b>iii</b>
	<b>ACKNOWLEDGMENT</b>	<b>iv</b>
	<b>LIST OF SYMBOLS AND ABBREVIATIONS</b>	<b>v</b>
	<b>LIST OF FIGURES</b>	<b>vi</b>
	<b>ABSTRACT</b>	<b>vii</b>
	<b>ABSTRAK</b>	<b>viii</b>
	<b>TABLE OF CONTENT</b>	<b>ix</b>
<b>1</b>	<b>INTRODUCTION</b>	
	1.1 Introduction	1
	1.2 Objectives of Project	2
	1.3 Scope of Project	3
	1.4 Problem Statement	3
	1.5 Outline of Thesis	3
	1.6 Gantt Charts	4
<b>2</b>	<b>LITERATURE REVIEWS</b>	
	2.1 Introduction	6
	2.2 PSCAD	6
	2.3 MATLAB	9
	2.4 FACTS	9
	2.5 Research Background	11
	2.6 Location of SSSC (Theory)	12
	2.7 Theory of SSSC	13
	2.7.1 Basic Control of SSSC	15
	2.7.2 Basic Operating Principles of the SSSC	17
	2.8 Voltage-Sourced Converter	18
	2.8.1 Basic Concept of VSC	19
	2.8.2 Gate Turn Off (GTO)	21
	2.8.3 Snubber circuit	21
	2.9 Summary	22
<b>3</b>	<b>METHODOLOGIES</b>	
	3.1 Introduction	23
	3.2 Project Flow	23



	3.3 IEEE 9-Bus Test System	26
	3.4 Transmission Line Impedance	27
	3.5 SSSC Model	28
	3.6 Generating Firing Pulse	29
	3.7 Control of the Static Synchronous Series Compensator (SSSC)	30
	3.7.1 Source of the SSSC Voltages	30
	3.7.2 AC Voltages of the SSSC	31
	3.7.3 Magnitude Control of the SSSC Voltage	31
	3.7.4 Phase Angle Control of the SSSC Voltage	32
	3.7.5 PWM Technique	33
	3.8 Summary	33
<b>4</b>	<b>RESULT AND DISCUSSION</b>	
	4.1 Introduction	34
	4.2 Data and Calculation	35
	4.2.1 IEEE 9 Bus System from Matlab	35
	4.3 Data from Simulation of PSCAD	38
	4.3 Power Flow Analysis	38
	4.4 Location of SSSC	39
	4.5 Summary	47
<b>5</b>	<b>CONCLUSION</b>	
	5.1 Conclusion	48
	5.2 Future Recommendations	49
	<b>REFERENCE</b>	50
	<b>APPENDICES</b>	53

## CHAPTER 1

### INTRODUCTION

#### 1.1 Introduction

Some of the major issues that are involved in bulk power transmission are enhancing the level of power transfer capability of existing transmission lines and flexible control over power flow through these lines. To achieve the above goals, the current trend is to use solid state devices for faster control and reliable operation. Power electronic devices, which are used for power flow control, are categorized under the generic name of Flexible AC Transmission Systems (FACTS). There are three major facets of FACTS. They are shunt compensation, series compensation and phase angle regulation. Of these three, the series compensation is addressed in this project.

In the context of FACTS technology, there are two controllers which can be used to provide series reactive compensation; the thyristor controlled series capacitor (TCSC) and the static synchronous series compensator (SSSC). A static synchronous series compensator (SSSC) injects a magnitude-controllable, nearly sinusoidal voltage in series with the transmission system. The heart of the SSSC is a voltage source converter (VSC) that is supplied by a DC storage capacitor. The voltage injected by the SSSC is almost in quadrature with the transmission line current such that it emulates the behavior of a series inductor or capacitor [1]. Instead of using capacitor and reactor banks, a SSSC

employs self-commutated voltage-source switching converters to synthesize a three-phase voltage in quadrature with the line current and so accomplishes specific compensation objectives. In steady-state applications, the main interest is to use the SSSC for controlling either impedance line or power flow (active and/or reactive) in transmission lines.

SSSC is introduced to the power system to enhance the level of power transfer capability in transmission lines. Using IEEE 9 bus power system network along with SSSC, this project's goal is to analyze the performance of the power system by introducing SSSC into the system. Both models will be simulated using PSCAD and MATLAB software. The result of the performance will be analyzed and compared to determine the effectiveness of SSSC's application in power system.

## **1.2 Objectives**

The objectives of the project:

- i. To simulate SSSC model in IEEE 9 bus power system network using PSCAD and MATLAB software
- ii. To investigate the effects of implementing SSSC Controller in IEEE 9 bus power system.
- iii. To evaluate the performance of SSSC Controller by analyze the power flow analysis of the IEEE 9 bus power system network before and after SSSC applied.

### **1.3 Scope of Project**

There are 3 scopes that have been outlined in order to narrow and specific the project in such a way to achieve.

- i. Modeling SSSC in IEEE 9 bus power system network
- ii. Simulation on the SSSC model using PSCAD.
- iii. Analyze and compare the performance of 9 bus system before and after SSSC applied by consider the ability to improve the voltage profile and power transfer capability.

### **1.4 Problem Statement**

SSSC should be used in critical point of transmission line to control the electric power flow for purpose to decrease the reactive voltage. Therefore, in this project the performances of the SSSC Controllers are analyzed.

### **1.5 Outline of Thesis**

This thesis consists of 5 Chapters. The first chapter contained 5 sections, namely Background, Objective of Project, Scope of Project, Problem Statement and the Outline of the Thesis.

Chapter 2 will introduce PSCAD, MATLAB software, FACTS controllers and its background research. This chapter also elaborates the theory of SSSC and its principle operation by explaining the basic of VSC.

Chapter 3 elaborates on the determination of location of SSSC Controllers and the performance of SSSC Controllers. The chapter also presents the flow chart for proposed methodology and the control of SSSC.

Chapter 4 presents the results of simulation using PSCAD and MATLAB software. The chapter consists of simulation of test system in base case, and Simulations of System with SSSC Controller.

Lastly, Chapter 5 concludes the thesis and presents several suggestions for future work related to the project.

Task	Weeks													
	1	2	3	4	5	6	7	8	9	10	11	12	13	14
PSM Briefing	30/12/09													
Literature Review of Project														
PSCAD And MATLAB Learning														
Preparation Presentation Slide														
Register Title and Submit Abstract			14/01/10											
Submit Abstract + Presentation Slide + Evaluation form						12/02/10								
Seminar PSM 1								23/02/10- 24/02/10						
Submit PSM1 report + Log Book + Evaluation form													25/03/10	
Preparation of Seminar PSM 1														
Preparation of PSM 1 Report														

Figure 1.1: PSM1 Schedule

Task	Weeks													
	1	2	3	4	5	6	7	8	9	10	11	12	13	14
Meeting SV	█	█	█	█	█	█	█	█	█	█	█	█	█	█
PSCAD And MATLAB Learning	█	█	█	█	█	█	█	█						
Proceed Simulation and Design System Network	█	█	█	█	█	█	█	█	█					
Analyze Result of Simulation					█	█	█	█	█					
Submit Project Progress/Summary		█	█	█	█	█	█	█	█	█				
Preparation of PSM 2								█	█	█	█			
Presentation /Seminar PSM 2												█	█	
Writing Thesis/Report								█	█	█	█	█	█	
Submit Thesis/Report Draft												█	█	█

Figure 1.2 : PSM2 Schedule

## CHAPTER 2

### LITERATURE REVIEWS

#### 2.1 Introduction

In this chapter, the basic working principle of the FACTS Controllers will be discussed. It would also include brief overview of the continuous power flow analysis. Lastly, the reviews of related work would also be included.

#### 2.2 PSCAD (Power System Computer-Aided Design)

PSCAD becomes an indispensable tool for a variety of power system designs and studies. It is a multi-purpose tool. It is equally capable in the areas of power electronic design and simulation, power quality analysis, protection and electrical utility system planning studies [4].

As electrical power and power electronic systems become more prevalent in electric vehicles, ships, trains, and distributed generation systems, the need for easy-to-use and accurate simulation and modeling tools becomes ever more important. It is easier and much less expensive to design and optimize electrical devices and systems

prior to prototyping or manufacturing. Thus, PSCAD is becoming a true Power System Computer-Aided Design tool for a variety of industry applications [4].

PSCAD users include engineers and technologists from energy utilities, electrical equipment manufacturers, engineering consulting firms, and research and academic institutions. PSCAD is used in the planning, design, and operational phases of power systems. It is also very prevalent in power system research around the world.

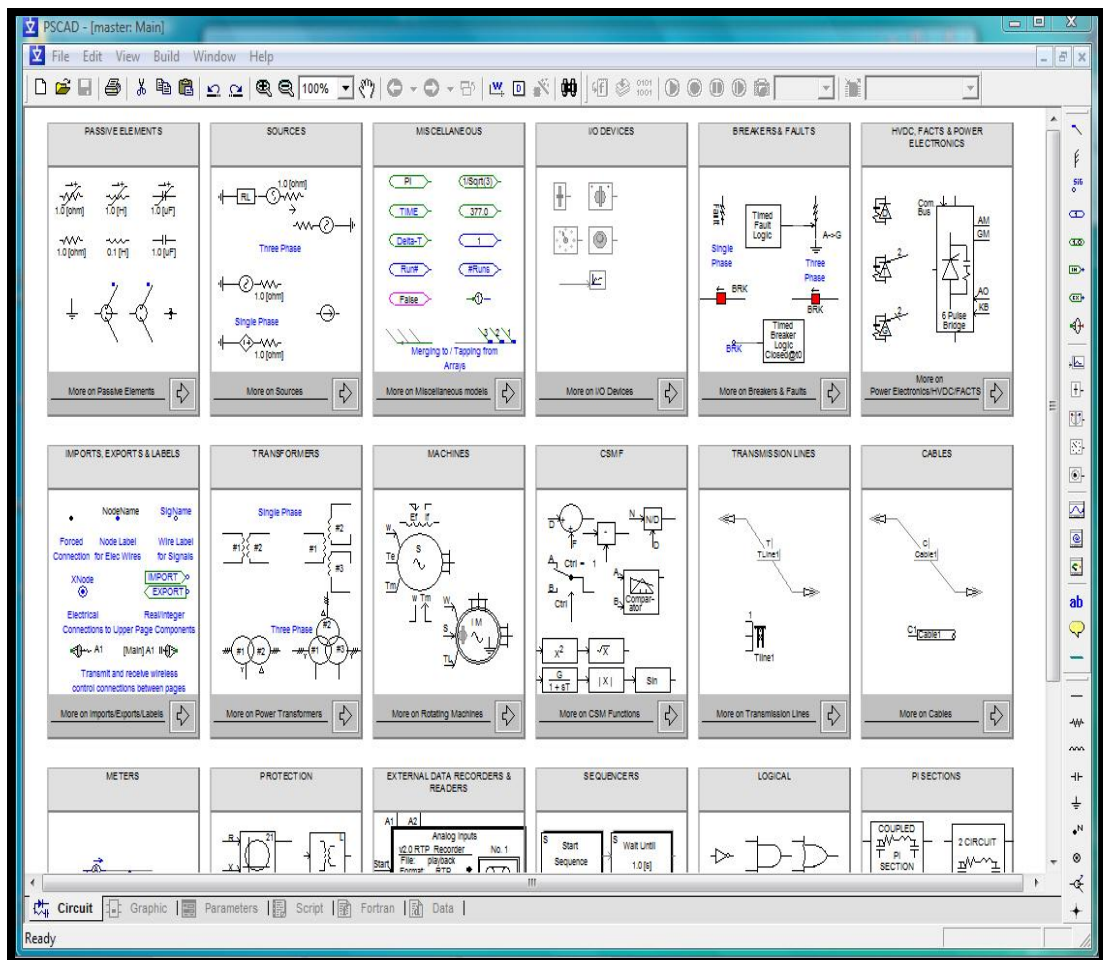

Figure 2.1: Master Library of PSCAD

Some typical examples of how PSCAD can be applied to better understand electrical power systems are:



- i. find overvoltage in a power system due to a fault or breaker operation. Transformer non-linearity (i.e. saturation) are a critical factor and are represented. Multiple run facilities are often used to run hundreds of simulations to find the worst case when varying the point on wave of the fault, type of fault, or location of the fault.
- ii. find overvoltage in a power system due to a lightning strike. This simulation would be performed with a very small time step (nano-seconds).
- iii. find the harmonics generated by a SVC, HVDC link, STATCOM, SSSC machine drive (virtually any power electronic device) using accurate models of thyristor, GTO, IGBT, and diode, along with the detailed control systems, analog or digital.
- iv. Analyze Power Quality related issues including harmonics, flicker and resonance problems.
- v. Applications in distribution networks.
- vi. Tune and design control systems for maximum performance. Multiple run facilities are often used here as well, to automatically adjust gains and time constants.
- vii. Modeling of FACTS with their detailed control models.
- viii. Study interactions between SVC, HVDC and other non-linear devices.
- ix. Investigate instabilities due to harmonic resonance or control interactions.
- x. Industrial systems, including compensation controllers, drives, electric furnaces, filters, etc.
- xi. Effect of transmission line imbalances on the system performance during contingencies.

PSCAD is a multi-purpose power system simulator and can thus be used for any scenario where a detailed understanding of the full time domain of analysis is beneficial. This includes the design and modeling of virtually any electrical power system.

### **2.3 MATLAB**

Matlab is a commercial "Matrix Laboratory" package which operates as an interactive programming environment. It is a mainstay of the Mathematics Department software lineup and is also available for PC's and Macintoshes and may be found on the CIRCA VAXes. Matlab is well adapted to numerical experiments since the underlying algorithms for Matlab's built in functions and supplied m-files are based on the standard libraries LINPACK and EISPACK.

Matlab program and script files always have filenames ending with ".m"; the programming language is exceptionally straightforward since almost every data object is assumed to be an array. Graphical output is available to supplement numerical results.

Matpower is a package of Matlab M-files for solving power flow and optimal power flow problems. It is intended as a simulation tool for researchers and educators that is easy to use and modify. Matpower is designed to give the best performance possible while keeping the code simple to understand and modify.

### **2.4 FACTS**

The solutions to improve the quality of supply in the electrical networks with distributed generation go through the application of the developments in semiconductor power devices, that is to say, the utilization of static power converters in electrical energy networks. The technological advances in power semiconductors are permitting the development of devices that react more like an ideal switch, totally controllable, admitting high frequencies of commutation to major levels of tension and power. The use of static power converters in electricity networks has the potential of increasing the

capacity of transmission of the electric lines and improving the supply quality of the electric energy. The devices used to achieve this, are the FACTS (Flexible Alternating Current Transmission Systems).

According to the IEEE the definition of FACTS device is : “Alternating Current Transmission Systems static and other power electronics controllers to improve the control and increase the capacity of power transfer”[5].

Table 2.1: Comparison of FACTS Devices

<b>DEVICES</b>	<b>LOAD FLOW CONTROL</b>	<b>VOLTAGE CONTROL</b>	<b>TRANSIENT STABILITY</b>	<b>OSCILLATION DAMPING</b>
SVC/STATCOM	SMALL	STRONG	SMALL	MEDIUM
TCSC	MEDIUM	SMALL	STRONG	MEDIUM
SSSC	STRONG	SMALL	STRONG	MEDIUM
UPFC	STRONG	STRONG	STRONG	STRONG

The FACTS controllers offer great opportunities to regulate the transmission of alternating current (AC), increasing or diminishing the power flow in specific lines and responding almost instantaneously to the stability problems. The potential of this technology is based on the possibility of controlling the route of the power flow and the ability of connecting networks that are not adequately interconnected, giving the possibility of trading energy between distant agents.

Table 2.2: FACTS Controller Control Attributes

<b>FACTS</b>	<b>Controller Control Attributes</b>
Static Synchronous Compensator (STATCOM Without storage)	Voltage control, VAR compensation, damping oscillations, voltage stability
Static Synchronous Compensator (STATCOM storage, BESS, SMES, large dc capacitor)	Voltage control, VAR compensation, damping oscillations, voltage stability, transient and dynamic stability, AGC
Static VAR Compensator (SVC, TCR, TCS, TRS)	Voltage control, VAR compensation, damping oscillations, voltage stability,

	transient and dynamic stability
Static Synchronous Series Compensator (SSSC with storage)	Current control, damping oscillations, voltage stability, transient and dynamic stability.
Static Synchronous Series Compensator (SSSC without storage)	Current control, damping oscillations, voltage stability, transient and dynamic stability, fault current limiting

## 2.5 Research Background

Due to deregulation of electricity markets, the need for new power flow controllers will certainly increase. The FACTS controllers offer the corrections of transmission capability, in order to fully utilize existing transmission system and controlling power flow while maintaining the system reliability [9]. FACTS controllers are based on high-power electronic switching devices called thyristors. The thyristor has indeed revolutionized the high power industry due to higher reliability, low cost, ruggedness and lower maintenance. FACTS application studies require careful planning and coordination in the specification, design and operating stage of project. Before meaningful results can be expected from the application studies, representative models for the transmission system and relevant FACTS controllers need to be established and verified. In this research work, it will focus on SSSC for series controller.

This research addresses the problem of regulating voltage and controlling power flow in power system using SSSC. This controller is also known as controlled reactive-power compensation devices. It provides the desired reactive power generation or absorption especially at the point of connection. Evaluation on the performance of this controller in steady state operation will be presented. Since the most important device for FACTS controllers are made of thyristor, Gate Turn-Off Thyristor (GTO) is used as the basic element of the voltage-sourced converter SSSC in this research. The GTO device is chosen because it facilitates current turn-on as well as turn-off by using control

signals. Furthermore, high-power GTOs are now available (100 mm, 6 kV or 150 mm, 9 kV) due to rapidly grown technology in this area [12].

In order to study in detail about SSSC, the 9 -bus system has been chosen to be implemented as a test system in PSCAD/EMTDC.

## **2.6 Location of SSSC (Theory)**

The SSSC were placed on the location in such a way that the capability of SSSC to compensate a particular bus or line could be optimized. Therefore, it is best if the SSSC would be located series with the weakest bus (in the case of series connected FACTS Controllers) or series with line that have the lowest percentage of underutilize capacity (in the case of series connected FACTS Controllers).

Therefore, continuous power flow analysis was applied in order to determine the weakest bus and the underutilized line in the test system. The test system was analyzed without the SSSC device and hence the original performance of the test system was required. Voltage profiles (bus voltage in per unit) for all the buses in the test network were plotted and the bus in which collapses the worst among other buses has been selected as the weak bus. On the other hand, based on the continuous power flow report, the most underutilized line was determined. The line in which has the lowest power flow out of its total rating was selected as the line that needs series compensation [6].

## 2.7 Theory of SSSC

The SSSC is generally connected in series with the transmission line with the arrangement as shown in Fig 2.1. The SSSC comprises a coupling transformer, a magnetic interface, voltage source converters (VSC) and a DC capacitor. The coupling transformer is connected in series with the transmission line and it injects the quadrature voltage into the transmission line. The magnetic interface is used to provide multi-pulse voltage configuration to eliminate low order harmonics. The injected voltage of the coupling transformer  $V_s$  is perpendicular to the line current  $I_L$ .

The SSSC is in principle a synchronous voltage source, which is typically connected in series with a transmission circuit to provide line compensation. This controllability is achieved by using a controllable interface between the dc voltage source (typically a capacitor) and the ac system. The series capacitive compensation basically to decrease the overall effective series transmission impedance from the sending end to the receiving end. The relationship characterizes the power transmission over a single line is:

$$P = \frac{V^2}{X} \sin \delta \quad (2.1)$$

Where:

$P$  - Real power transmission over a single line

$V$  - The sending end and receiving end voltage (assuming  $V_S = V_R = V$ )

$X$  - The line impedance

$\delta$  - The power angle

SSSC is a power converter connected in series with the transmission line and it injects a voltage in quadrature with the line current to emulate a series capacitive or inductive reactance into the transmission line [2, 3]. A SSSC equipped with energy storage system and/or absorbing is also able to exchange real power with power system.

Reactive power exchange is controlled by the magnitude of the injected voltage to the transmission line, and angle control is used to regulate the active power exchange. The inductive or capacitive mode of operation is set by the injected voltage phase angle with respect to the transmission line current. When injected voltage is leading the line current, reactive power is absorbed and SSSC operates in inductive mode. In capacitive mode injected voltage is lagging the line current and injects reactive power to the transmission line.

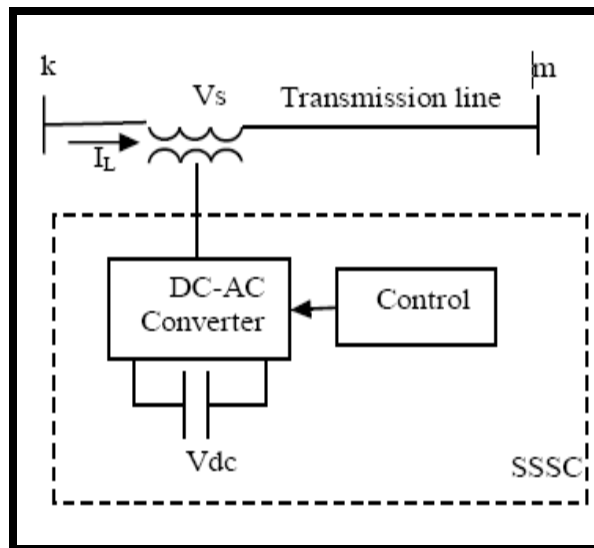

Figure 2.2: Simplified Diagram of SSSC

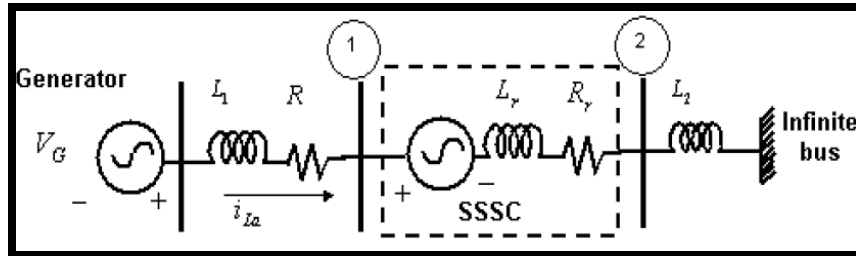

Figure 2.3: Line Diagram of SSSC

In the equivalent circuit of an SSSC compensated system, the SSSC is represented by a voltage source and impedance ( $L_r, R_r$ ). The SSSC is connected between buses 1 and 2. The pair ( $L_1, R$ ) represents the line and  $L_2$  represents a transformer.

### 2.7.1 Basic Control of SSSC

The main function of the SSSC is to control the real power flow. This can be accomplished either by direct control of the line current (power) or alternatively by indirect control of the compensating impedance,  $X_s$ , or the compensating voltage,  $V_c$  (1). The direct power flow control has the advantage of maintaining the transmitted power in a closed loop manner by the defined reference. However under some network contingency, the maintenance of the constant power flow may not be either possible or even desirable. Therefore in some applications the impedance (or voltage) control that maintains the impedance characteristic of the line may be preferred from the operating standpoint. The degree of series impedance compensation,  $S$ , is usually expressed as the ratio of the series injected reactance  $X_s$ , to the line reactants,  $X_l$ ,  $S = X_s/X_l$ . Therefore for a capacitive series compensation, the line series reactants is  $X_{line} = X_l - X_s$ , where  $X_s = S X_l$ . Similarly for an inductive series compensation the line series reactance is  $X_{line} = X_l + X_s$  where  $X_s = S X_l$ . The basic function of the control system is to keep the SSSC voltage,  $V_c$  in quadrature with the line current  $I_L$  and control the magnitude of  $V_c$  to meet the compensation requirement, which is the degree of series compensation.