

THE CHARACTERISTIC STUDY OF ROTATION AND ELEVATION TECHNIQUE
OF SOLAR TRACKER

MOHD ZUL-FADLY BIN ZAINUDDIN

This thesis is submitted as partial fulfillment of the requirements for the award of the
Bachelor of Electrical Engineering (Electronics)

Faculty of Electrical & Electronics Engineering
Universiti Malaysia Pahang

NOVEMBER, 2009

I declare that this thesis entitled “THE CHARACTERISTIC STUDY OF ROTATION AND ELEVATION TECHNIQUE OF SOLAR TRACKER” is the result of my own research except as cited in the references. The thesis has not been accepted for any degree and is not concurrently submitted in candidature of any other degree.

Signature : _____

Name : MOHD ZUL-FADLY BIN ZAINUDDIN

Date : 24 NOVEMBER 2009

ACKNOWLEDGEMENT

In the name of Allah S.W.T, the most Gracious, the ever Merciful, Praise is to Allah, Lord of the universe and Peace and Prayers be upon His final Prophet and Messenger Muhammad S.A.W.

First and foremost, I want to express my great deepest gratitude for my supervisor, Mr. Omar Bin Aliman for his continued support, encouragement, and guidance in overseeing the progress of my project from initial phase until it's complete. Without his valuable advices and comments, this project would not have been possible to finish.

To all my friends and course mates, thank you for believing in me and support me from beginning until this project is finished. The experience and knowledge I gained would help me to face the challenges lie ahead.

Last but definitely not the least to my parent and my family, I would never thank enough for their love, and for supporting me throughout my studies in University Malaysia Pahang (UMP).

ABSTRACT

Solar tracker is a device at solar panel which the characteristic of this device is it will track the motion of sun across the sky to ensure the amount of sunlight strikes at the solar panel are maximum. Currently, there are two techniques to control the solar tracker which is rotation-elevation technique and azimuthally-elevation technique. A characteristic study on the rotation and elevation tracking technique in solar tracker is proposed. The study will focus on the characteristic of this tracking technique and prove this concept by demonstrating this technique in practical. The characteristic study will base on the parameter in the equation involved in this tracking technique and plotted graph. Several parameters then will be manipulated to see the effect of that parameter to the plotted graph. The process of demonstrating this technique in practical will be made with several considerations. The benefit of this study is that it can help the future research related with this tracking technique to be their reference for their research.

ABSTRAK

Pengesan solar adalah satu alat yang terdapat pada panel solar di mana mempunyai ciri-ciri untuk mengesan pergerakan matahari di atas langit untuk memastikan jumlah cahaya matahari yang diterima oleh panel solar dapat dimaksimumkan. Buat masa ini, terdapat dua teknik untuk mengawal pengesan solar. Teknik pertama adalah pergerakan berdasarkan orientasi kiri-kanan dan depan-belakang. Teknik yang kedua pula adalah pergerakan berdasarkan orientasi putaran dan depan-belakang. Kajian untuk mengenal pasti ciri-ciri teknik berdasarkan pergerakan orientasi putaran dan depan-belakang diutarakan. Kajian ini akan berfokuskan pada ciri-ciri teknik tersebut dan membuktikan teknik ini dengan menjalankan ujian secara praktikal. Kajian pada ciri-ciri teknik ini akan berdasarkan pada parameter yang terdapat di dalam persamaan yang terlibat di dalam teknik ini dan graf yang terhasil. Beberapa parameter kemudiannya akan diubah bagi melihat kesan perubahan parameter tersebut pada graf yang terhasil. Proses menjalankan ujian secara praktikal akan dijalankan berdasarkan beberapa pertimbangan yang perlu dipatuhi. Kajian ini akan dapat membantu kajian yang akan dijalankan pada masa hadapan yang berkaitan dengan teknik ini sebagai rujukan untuk kajian tersebut.

TABLE OF CONTENTS

CHAPTER	ELEMENTS	PAGE
	DECLARATION	ii
	DEDICATION	iii
	ACKNOWLEDGEMENT	iv
	ABSTRACT	v
	TABLE OF CONTENTS	vii
	LIST OF FIGURES	x
	LIST OF APPENDICES	xii
CHAPTER 1	INTRODUCTION	
	1.1 Background	1
	1.2 Project objective	2
	1.3 Problem statement	2
	1.4 Project scope	3
	1.5 Thesis outline	3
CHAPTER 2	LITERATURE REVIEW	5

CHAPTER 3	METHODOLOGY	
3.1	Introduction	8
3.2	Rotation and Elevation Movement	
3.2.1	Rotation movement	10
3.2.2	Elevation movement	10
3.3	Principle of rotation and elevation	11
	Tracking technique	
3.4	Hardware development	15
3.4.1	Parallel port	15
3.4.2	Stepper motor	16
3.4.3	Stepper motor driver	18
3.4.4	Circuit diagram	18
3.5	Software development	19
3.5.1	Introduction	19
3.5.2	Characteristic Study	20
3.5.3	Controller Development	23
3.5.4	Coding Example in VBA	27
CHAPTER 4	RESULT AND ANALYSIS	
4.1	Introduction	30
4.2	Figure explanation	30

CHAPTER 5**CONCLUSION AND RECOMMENDATION**

5.0	Conclusion	38
5.1	Future Recommendation	39

REFERENCES**APPENDICES****A**

LIST OF FIGURES

FIGURE	TITLE	PAGE
2	Example of Solar Tracker using CdS photocell	5
3.1	Rotation modes of rotation and elevation tracking Technique	9
3.2	Diagram to show the rotation and elevation axes	10
3.3a	Coordinate system attached to earth reference frame	11
3.3b	Coordinate system attached to the local heliostat Reference frame	11
3.4.1	Parallel port configuration	15
3.4.2	Electrical drawing for the stepper motor	18
3.4.4	Circuit diagram	19
3.5.2	Table to study the characteristic of the rotation And elevation technique	20
3.5.3a	Controller 1	24
3.5.3b	Controller 2	25
3.5.3c	Controller 3	26
3.5.3d	Controller 4	27
3.5.4.1	Declaration of parallel port in VBA	28
3.5.4.2	Coding for running the stepper motor in VBA	28
3.5.4.3	Coding for displaying the current time	29

4.2.1	Manipulation of Solar Time - Latitude Angle, Φ , (Malaysia, 3.83° due to North), Facing Angle, ϕ , (1.20°), and Target Angle, λ , (0°)	31
4.2.2	Manipulation of Solar Time - Latitude Angle, Φ , (Beijing, 39.93° due to North), Facing Angle, ϕ , (1.20°), and Target Angle, λ , (0°)	32
4.2.3	Manipulation of Solar Time - Latitude Angle, Φ , (Mumbai, 18.56° due to North), Facing Angle, ϕ , (1.20°), and Target Angle, λ , (0°)	33
4.2.4	Manipulation of Solar Time - Latitude Angle, Φ , (Malaysia, 3.83° due to North), Facing Angle, ϕ , (10°), and Target Angle, λ , (0°)	34
4.2.5	Manipulation of Solar Time - Latitude Angle, Φ , (Malaysia, 3.83° due to North), Facing Angle, ϕ , (-10°), and Target Angle, λ , (0°)	35
4.2.6	Manipulation of Solar Time - Latitude Angle, Φ , (Malaysia, 3.83° due to North), Facing Angle, ϕ , (1.20°), and Target Angle, λ , (10°)	36
4.2.7	Manipulation of Solar Time - Latitude Angle, Φ , (Malaysia, 3.83° due to North), Facing Angle, ϕ , (1.20°), and Target Angle, λ , (-10°)	37

LIST OF APPENDICES

APPENDIX	TITLE	PAGE
A1	Datasheet for ULN2003 for Stepper Motor Driver	
A2	Datasheet for ULN2003 for Stepper Motor Driver	

LIST OF ABBREVIATION

VBA	Visual Basic for Application
CDS	Cadmium Sulphide

CHAPTER 1

INTRODUCTION

1.1 Background

Solar thermal energy (STE) is a technology for harnessing the solar energy for thermal energy by using solar thermal collector. There are two type of solar thermal energy application that is low –temperature solar thermal collectors and high-temperature concentrating solar thermal electric (HTSTE). Low temperature collectors are flat plate that generally used to heat swimming pool, space heating and process that involved heating process. High temperature collector concentrated the sunlight using mirror or lenses to heat a fluid through a turbine power generator. HTSTSE system used two type of solar collector that is moving target type and fixed target type. Parabolic dish, linear Fresnel and parabolic trough are the example of moving target type while solar tower is the examples of fixed target type. For moving target type usually are for small scale project and lower power application compared to the fixed target type.

This project will focus on the technique that will be used to move the heliostat in order to track the motion of the sun. The rotational-elevation technique is one of the examples of technique that can be applied in order to get high practicability and competency in solar tracker. This project can help future research on developing a

new technique based on the rotation-elevation technique on the solar tracker to get high practicability and competency in reality.

1.2 Project Objective

- To study the characteristic of the rotational-elevation technique of solar tracker
- To prove the concept of rotational-elevation technique by demonstrating this technique in practical

This project put an objective to complete the study of the characteristic of rotation and elevation technique in terms of parameter in the equation and hardware development in order to demonstrate this technique in practical.

1.3 Problems statement

Solar tower is one of the technologies in solar system. This type of solar thermal energy system usually applied for large power generation and required large space to place hundred of solar panel. This solar panel were designed to reflect the sunlight to the receiver at the top of solar tower usually located at the central of generation plant. To increase the efficiency in solar system, the power output from the generation plant need to be maximize. In order to maximize the power output from a solar system, all of the solar panel must always align with the movement of sun. To control the solar panel to track the motion of the sun, solar tracker is used.

The solar tracker will support the movement of the solar panel according to the motion of the sun. Currently, there are two techniques on how the solar tracker moves the solar panel that is azimuthally-elevation technique and rotation-elevation technique. In azimuthally-elevation technique, by considering of one solar panel, to realize the sunlight focusing, each mirror on the solar panel needs to be manipulated

varied time. By considering of M row and N columns of element of mirror in the one solar panel and one solar panel have two degree of freedom, the number of controlling device that have to be used is $2 \times (M \times N)$. This will reduce the practicability and competency on this technique. Therefore, a new technique had being proposed by replacing the azimuth direction with the rotation direction and then elevation. Although this method is not popular as azimuth technique, this technique had been mentioned by some authors in a previous publication. This project proposed a research on the characteristic of rotational-elevation technique to prove this concept by demonstrating this technique in practical.

1.4 Project scope

The development of solar tracker has increase the efficiency of power generation. The development has included the consideration of the shape of solar thermal collector, design of solar tower and technique on moving the heliostat. In solar tower case, to produced high power generation, a large number of heliostat need to be used and several technique had being developed on the way the heliostat will track the motion of the sun.

This project will be discussed based on rotation-elevation technique. The rotational-elevation technique is a technique based on the rotational axis and elevation axis. The process of identifying the characteristic of this technique will be done by taking a single heliostat as a reference based on the parameter which involved in the mathematical equation only.. In hardware demonstration, two stepper motor will represent as a single heliostat. The movement of stepper motor is according to the change of second in current time.

1.5 Thesis outline

This thesis contain of 5 chapters they include Chapter 1: Introduction, Chapter 2: Literature reviews, Chapter 3: Methodology, Chapter 4: Software development, Chapter: Result and discussion. Each chapter will contribute to explain different focus and discussion relating with the corresponding chapters heading.

Chapter 1 contain introduction which present about the overviews of the project that is constructed. It consists of project background, objective, problem statement and project scope.

Chapter 2 contain literature review which discussed about the reference that is taken for this project completion.

Chapter 3 will discuss about the methodology in this project which consist of characteristic study of rotation and elevation technique, the construction of the hardware and development of controller for this project.

Chapter 4 contain result and discussion focused on the analysis of the result acquired and discussed the outcome that is obtained.

Chapter 5 contain conclusion and recommendations for this project

CHAPTER 2

LITERATURE REVIEW

Currently, there are many type of solar tracker that already being developed in order to track the motion of sun to achieved high concentration of sunlight. There was solar tracker which applied light dependent resistor in order to detect the present of sun. This type of solar tracker uses a cadmium sulphide (CdS) photocell for light sensing. The CdS photocell is a passive component whose resistance is inversely proportional to the amount of light intensity directed toward it. The photocell is placed in series in order to utilize the photocell. The photocell then was placed in the top position in order to increase the light intensity. The photocell will use a stepper motor for precision positioning control application. Other method which had been proposed is by using two phototransistors covered with a small plate to act as a shield to sunlight.

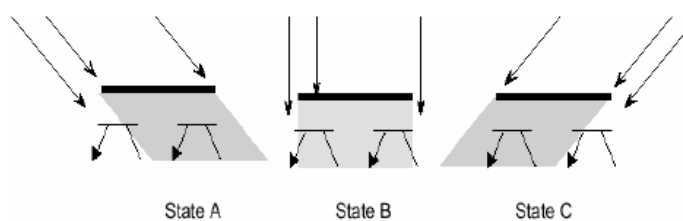

Figure 2: Example of Solar Tracker using CdS photocell

In this system, by referring figure above, in the morning, the tracker in state A from the previous day. The left phototransistor is turned on, causing a signal to turn the

motor continuously until the shadow from the plate returns the tracker to state B. As the day slowly progresses, state C is reached shortly, turning on the right phototransistor. The motors turn until state B is reached again, and the cycle continues until the end of the day or until the minimum detectable light level is reached. This system provide an excellent mechanism in light intensity detection because this system are sensitive to varying light and provide a near-linear voltage range that can be used to an advantage in determining the present declination or angle to the sun. Both examples above are using a single axis technique which is better compared to a fixed solar panel. For two axis tracker, currently there are two types that is azimuthally-elevation and rotational-elevation technique. For rotational-elevation technique, the prototypes of this project had been proposed by a team of researcher in Malaysia. The characteristic study about this technique will help the development of the solar tracker which has high applicability and efficiency in order to produce large power generation.

The conventional heliostat can be categorized as not applicable because it experienced strong astigmatic aberration whenever the reflection is off-axis. The aberration will increase the sun's image size on the target which leads to a significant spillage loss, a reduction in the average flux on the receiver, and a reduction in receiver efficiency.

To solve this problem, several author proposed their study such as Igel and Hughes [1] which realized that the amount of aberration depends on the incidence angle as measured in the tangential plane, defined by the sun, the centre of the heliostat, and the target. According to their study, the image size could be reduced if the heliostat can be constructed with asymmetric curvature, but this requires that the heliostat be aligned with the tangential plane rather than just pointing at the target. In addition, they also propose to rotate the heliostat frame about the normal of the centre facet, in addition to the azimuth and elevation motions, to achieve this alignment which is mechanically cumbersome and too expensive to be practical.

Ries [2] and Zaibel *et al.* [3] made another proposal to use a target aligned mount method for sun tracking. In this method, the sagittal and tangential directions

are fixed with respect to the heliostat frame. The aberration can then be corrected by using a non-symmetric heliostat with two different radii of curvature. They noted that the correction is different for each time, and computed the fixed asymmetric curvature that would provide the best annual average correction.

Chen *et al.* [4, 5] derived the sun tracking formula for the rotation-elevation tracking mount, where the rotation axis points towards the target and keeps the heliostat normal within the tangential plane, and the elevation axis rotates the heliostat normal within the tangential plane. They proposed a heliostat with a dynamically adjusted geometry that has the ability to make a full aberration correction. It is composed of a number of smaller movable facet mirrors, which can be manoeuvred to make the first-order aberration correction.

The new design was therefore named “non-imaging focusing heliostat”. The shape of the non-imaging focusing heliostat is similar to the shape of non-symmetric geometry proposed by Ries *et al.* [2, 3], having two different radii of curvature along the row and column directions. However, this is only true when the distance between the target and heliostat is large relative to the dimension of the heliostat. The rotation-elevation techniques provides the only mode to link the movements of all the facets using a small number of motors, and thus reduce the number of controls to the minimum. The application of non-imaging focusing heliostats in a heliostat field, e.g., in a solar power plant, requires a significant emphasis on cost reduction since the heliostat cost is a major factor in the overall plant cost-effectiveness. A fixed geometry of the heliostat is therefore preferred relative to the dynamic facet alignment.

CHAPTER 3

METHODOLOGY

3.1 Introduction

In the rotation-elevation technique, it has the advantage on the elevation axis which will maintain perpendicular to the plane consisting of the mirror normal, the sun and the target for example the plane of reflection. Figure 1 will explain detail about the rotation and elevation axis. Previous research had been developed by a group of researcher which related with the characteristic of rotation and elevation technique. The research had been conducted by a student from Faculty of electrical Engineering of University of Technology Malaysia titled 'Non-Imaging Focusing Heliostat'. According from the research, there are two principle involved in the rotational-elevation axis technique operation that is primary tracking and secondary tracking. In this study, only the primary tracking will be involved because it related with the rotation and elevation technique. The purpose of the primary tracking is to target the solar image of the master mirror into a fixed target. This image will function as a reference for secondary tracking where the entire slave mirror is projected at the solar image.

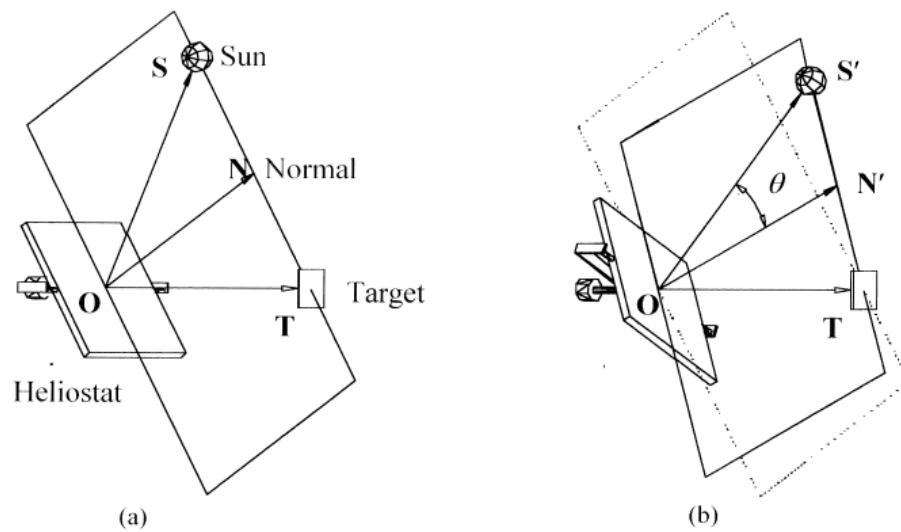

Figure 3.1: Rotation modes of rotation and elevation tracking technique

From Figure 3.1(a), ON is defined as a vector normal to the reflector surfaces. OS is a vector that points the sun and OT is the vector that point to a fixed target. Figure 3.1(b) show the rotation of the plane reflection. Vector OS' points to the new position of sun and the vector ON' is the reflector normal of the new orientation so that the vector OT still point to a fixed target. The tracking movement in this technique can be studied by two independently component (referring to Figure 3.2).

3.2 Rotation and Elevation movement

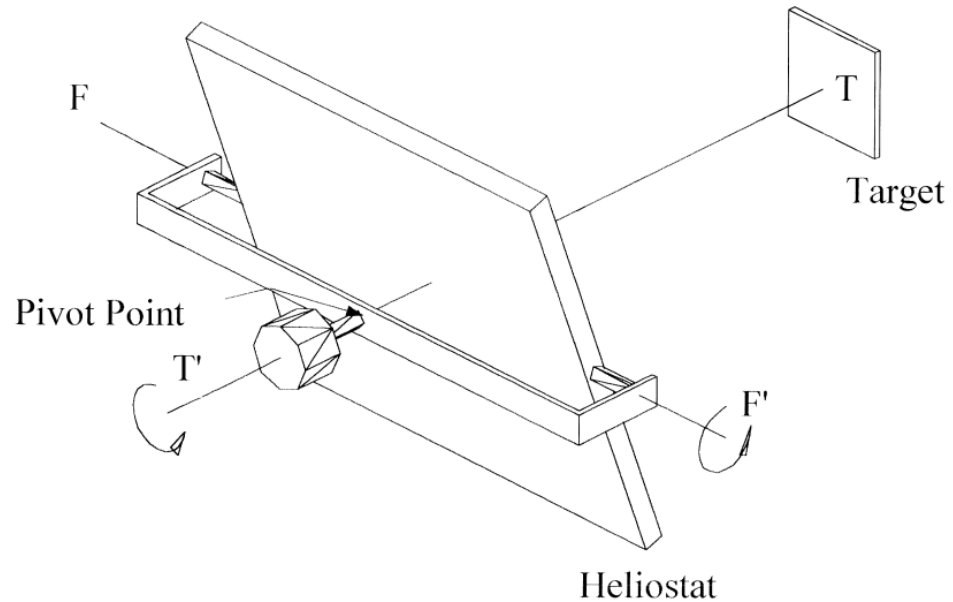

Figure 3.2: Diagram to show the rotation and elevation axes

3.2.1 Rotation movement

The heliostat has to rotate about the TT' axis so that the plane of reflection can follow the rotation of the vector OS. Therefore, as the sun moves through sky at solar from the morning until solar noon, the plane will rotate starting from the horizontal and turning to vertical. The angular movement of this rotation axis is denoted as ρ .

3.2.2 Elevation movement

The rotation of the heliostat on the FF' axis which is perpendicular to the plane will adjust the reflector normal position within the plane until it bisects the angle between OS and OT. As a result, the sunlight will be reflected onto the target.

This angular movement depends on the incidence angle of the sun relative to the heliostat surface normal and it is denoted as θ .

3.2 Principle of Rotation and Elevation Tracking Technique

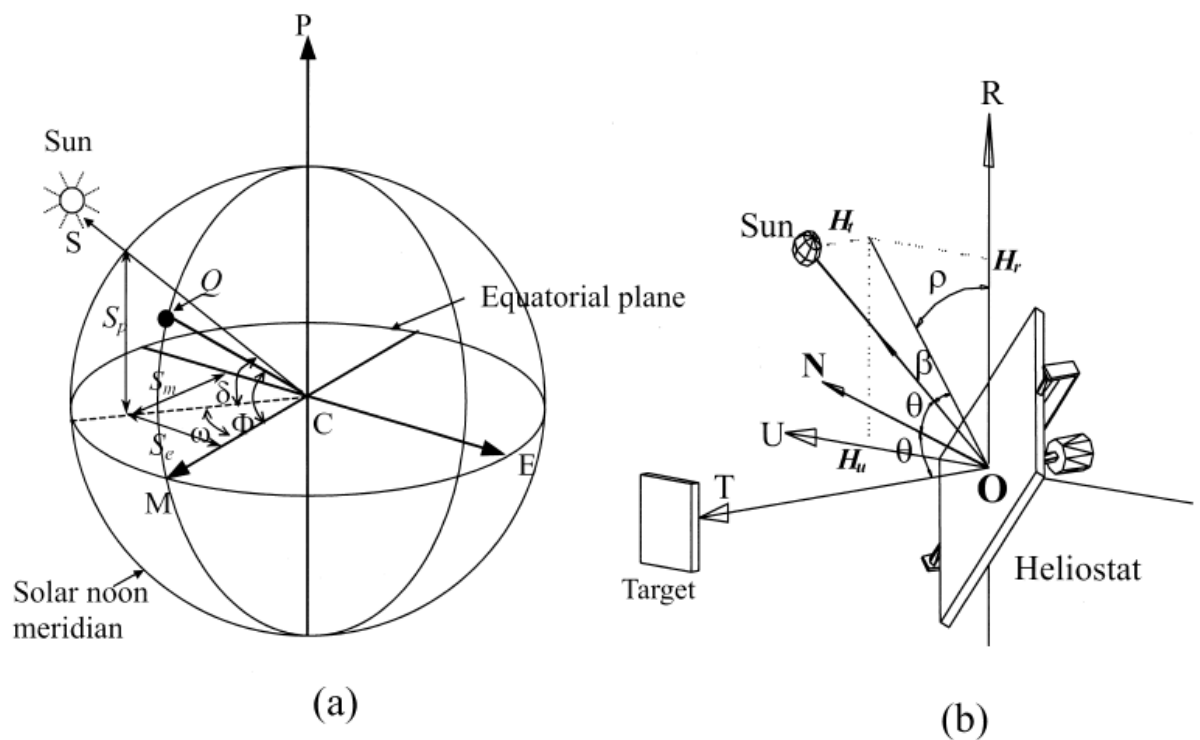

Figure 3.3a: Coordinate system attached to earth reference frame **Figure 3.3b:**

Coordinate system attached to the local heliostat reference frame

From Figure 3.3a, by taking the coordinate system attached to earth frame as a reference, the vector CS that points towards the sun can be described in terms of hour angle, ω and the declination angle, δ . The observer, Q is located at the latitude angle of Φ . Consider a coordinate system with the origin, C; set at the centre of the earth, the CM axis is a line from the origin to the intersection point between the equator and the meridian of the observer at Q. The CE (east) axis in the equatorial plane is

perpendicular to CM axis. The third orthogonal axis, CP is the rotation axis of the earth. The vector CS which pointing the sun can be described in terms of its direction cosines, S_m , S_e and S_p to the axes of CM, CE and CP respectively. Given the direction cosines of CS in terms of declination angle (δ) and hour angle (ω), the set of coordinates in matrix form can be derived as

$$S = \begin{bmatrix} S_m \\ S_e \\ S_p \end{bmatrix} = \begin{bmatrix} \text{Cos} \delta \text{Cos} \omega \\ -\text{Cos} \delta \text{Sin} \omega \\ \text{Sin} \delta \end{bmatrix} \quad [1]$$

From Figure 3.3b, by taking the coordinate system attached to the local heliostat as a reference frame, the origin of the coordinate system is defined at the centre of the master mirror and denoted as O. The OR axis is parallel with the array of mirrors arranged in the horizontal direction. The third orthogonal axis, OT axis is a line pointing out from the origin towards the target direction. The angle between the vector OS and its projection on the plane that contains the OR and OU axes denoted as β . The rotation angle denoted as ρ while elevation angle as θ and both angle are used to determine the position of the heliostat according to the position of the sun at current time. Vector OS which pointing toward the sun can be described in terms of its direction cosines, H_r , H_u and H_t to the OR, OU and OT axes respectively. In daily sun tracking, the elevation axis (FF') is rotated about the OT axis from the morning to the evening, but the OR and OU axis and the FF' axis is ρ and these two axes coincides with each other at solar noon. In terms of the angles β and ρ , the vector OS can be represent in the matrix form

$$H = \begin{bmatrix} H_f \\ H_r \\ H_t \end{bmatrix} = \begin{bmatrix} \text{Cos} \beta \text{Cos} \rho \\ -\text{Cos} \beta \text{Sin} \rho \\ \text{Sin} \beta \end{bmatrix} \quad [2]$$

From the law of reflection, Figures 1 and 3 show that θ is obviously:

$$\theta = \frac{1}{2} \left(\frac{\pi}{2} - \beta \right) \quad [3]$$

The new set of coordinates, \mathbf{H} , can be interrelated to the earth frame based coordinates, \mathbf{S} , by three successive rotation transformation. The first transformation is effected by a rotation about the CE axis through the latitude angle Φ like illustrated in Figures 3(a). In matrix notation, it takes the form

$$\Phi = \begin{bmatrix} \text{Cos}\Phi & 0 & \text{Sin}\Phi \\ 0 & 1 & 0 \\ -\text{Sin}\Phi & 0 & \text{Cos}\Phi \end{bmatrix} \quad [4]$$

In the non-imaging focusing heliostat, the rotation axis (TT' axis) has to be aligned pointing towards the target and the elevation axis (FF' axis) is perpendicular to the first axis and attached parallel to the reflector. If more than one heliostat shares a common target, each heliostat has its own orientation of the rotation axis relative to the earth surface. Taking into account of the orientation angles of the rotation axis, which are facing angle ϕ and target angle λ , it is necessary to have two transformations. The facing angles, ϕ , is the rotation angles about the Zenith made by the rotation axis (OT) when it rotates from the direction pointing towards north to the direction pointing towards a fixed target (assuming that the fixed target and central point of master mirror are the same horizontal level). Hence, $\phi = 0^\circ$ if the heliostat is placed due south of the target and $\phi = 90^\circ$ if the heliostat is located due to west of the target. The transformation matrix for the angle ϕ about the Zenith is

$$\phi = \begin{bmatrix} 1 & 0 & 0 \\ 0 & \text{Cos}\phi & -\text{Sin}\phi \\ 0 & \text{Sin}\phi & \text{Cos}\phi \end{bmatrix} \quad [5]$$