

An Investigation of Profiles for Plate Cams with Vertical In-line Roller Followers

M.R.M.Rejab, K.Kadrigama, M.M.Noor, Z.Ahmad@Manap, M.M.Rahman, R.Daud and M.S.M.Sani

Abstract— This paper presents an evaluation of graphical method and experimental work for determining plate cam profiles. Both methods are accurate for obtaining points on a cam with vertical roller followers. The coordinates of the centre of the follower are required at small increments of the cam angle. It can be easily programmed and depend only on the follower coordinates and not the follower type. A comparison on motion analysis has been made to determine the percentage error occurred in both methods. From result between graphical and experimental methods, the different of the follower displacement calculated and shows the small value of displacement occur among them where less than 5 %.

Keywords: Plate Cams, Vertical In-line Roller Follower, Mechanism Analysis

I. INTRODUCTION

Cam mechanism is preferred over a wide variety of machines because the cam is possible to obtain an unlimited variety of motions. The cam has a very important function in the operation of many classes of machines, especially those of the automatic type, such as printing presses, shoe machinery, textile machinery, gear-cutting machines, and screw machines. The cam may be defined as a machine element having a curved outline or a curved groove, which, by its oscillation or rotation motion, gives a predetermined specified motion to another element called the follower [1]. In other word, cam mechanism transforms a rotational or oscillating motion to a translating or linear motion. In fact, cam can be used to obtain unusual or irregular motion that would be difficult to obtain from other linkage.

The variety of different types of cam and follower systems that one can choose from is quite broad. It depends on the shape of contacting surface of the cam and the profile of the follower. Cams are made in a variety of forms, including a rotating disk plate with radial required profile, a reciprocating wedge of a required shape, a cylindrical barrel cam with a follower groove cut in a diameter and a cylindrical with required profile cut in the end. [1,5].

The transformation of one of the simple motions, such as rotation, into any other motions is often conveniently accomplished [2]. Cam is the common mechanism element that drives a mating component. A cam mechanism usually consists of two moving elements, the cam and the follower, mounted on a fixed frame. The cam mechanism can be classified by the modes of input/output motion, configuration and arrangement of the follower, and the shape of the cam [3].

Fig. 1 shows the nomenclature of typical designing of cam shape. In the figure, pitch curve is a path generated by the trace point at the follower is rotated about a stationary cam. Pitch circle is a circle from the cam center through the pitch point. The pitch circle radius is used to calculate a cam of minimum size for a given pressure angle. Prime circle is a smallest circle from the cam center through the pitch curve. Base circle is a smallest circle from the cam center through the cam profile curve.

Follower travel is a position of the follower from a specific zero or rest position in relation to time or the rotary angle of the cam. Pressure angle is an angle at any point between the normal to the pitch curve and the instantaneous direction of the follower motion. This angle is important in cam design because it represents the steepness of the cam profile.

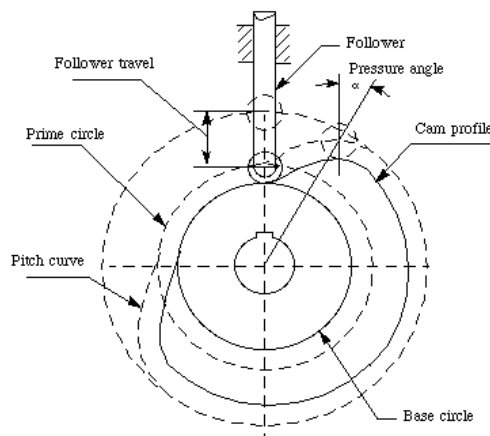

Figure 1. Cam Nomenclature [3]

When the cam turns through one motion cycle, the follower executes a series of events consisting of rises, dwells and returns. Rise is the motion of the follower away from the cam center, dwell is the motion during which the follower is at rest; and return is the motion of the follower toward the cam center [1, 4, 5, 6].

Design of Disk cam with roller follower

Nowadays, method for design plate cam became more complex and sophisticated. Recent methods focus on the design of dynamically compensated cams with the purpose of minimizing residual vibrations in high speed cam-follower systems [7]. The basic principle of designing a cam profile with the inversion method is still used. However, the curve is not directly generated by inversion. In Fig. 2 show this procedure where it has two steps

- (i) Imagine the center of the roller as a knife edge. This concept is important in cam profile design and is called the trace point of follower. Calculate the pitch curve aa , that is, the trace of the pitch point in the inverted mechanism.
- (ii) The cam profile bb is a product of the enveloping motion of a series of rollers.

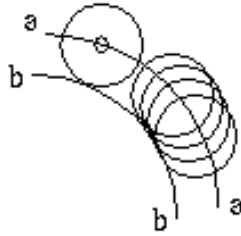

Figure 2. The trace point of the follower on a plate cam

The problem of calculating the coordinates of the cam profile is the problem of calculating the tangent points of a sequence of rollers in the inverted mechanism. At the moment shown Fig. 3, the tangent point is **P** on the cam profile.

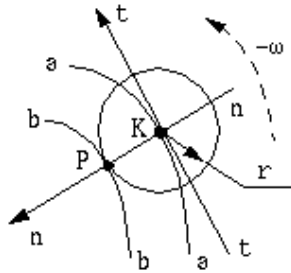

Figure 3. The tangent point, P, of a roller to the plate cam

The calculation of the coordinates of the point **P** has two steps:

- (i) Calculate the slope of the tangent tt of point **K** on pitch curve, aa .
- (ii) Calculate the slope of the normal nn of the curve aa at point **K**.
- (iii) Since we have already have the coordinates of point **K**: (x, y) , we can express the coordinates of point **P** as

$$\begin{cases} x_p = x - IW \cdot RM \cdot r \cdot \frac{dy/d\phi}{\sqrt{(dx/d\phi)^2 + (dy/d\phi)^2}} \\ y_p = y + IW \cdot RM \cdot r \cdot \frac{dx/d\phi}{\sqrt{(dx/d\phi)^2 + (dy/d\phi)^2}} \end{cases}$$

where;

IW = A parameter whose absolute value is 1. It represents the turning direction of the cam. r = the radius of the roller.

IM = A parameter whose absolute value is 1, indicating which envelope curve will be adopted.

RM = inner or outer envelope curve. When it is an inner envelope curve: $RM=+1$, otherwise: $RM=-1$.

II. EXPERIMENTS

In this design, ellipse shape was chosen to be analyzed. This shape is a basic shape that generally use in the industries nowadays. This shape has been chosen because of the performance between input data can be differentiate and can be analyzed according to the several parameters that been considered. The Fig. 4 shows the shape and geometry of the heart shape cam.

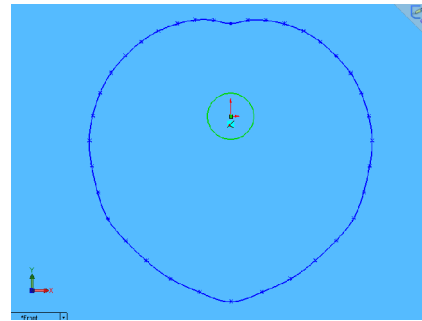

Figure 4. Heart shape of cam

Cam Mechanism Analysis System

In analyzing cam motion mechanism, the machine that had been used is cam mechanism analysis system, as shown in Fig. 5. This system is used Dewesoft software to run and gathering the experimental data.

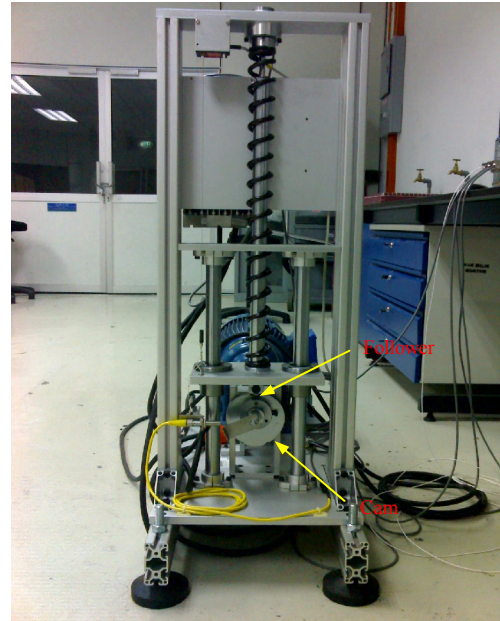

Figure 5. Cam mechanism analysis system

From this experiment, the parameters that gathered were displacement (s), velocity (v) and acceleration (a) of the follower. From this data, the performance of the cam and follower system can be analyzed and had been compared with the theoretical analysis.

Data collection method

From the heart shape of cam that had be used, the performance of this type of the cam using kinematics parameter can be differentiate from the experiment in the cam mechanism analysis system using different speed of cam. In this experiment, the speeds of cam that used were 100 rpm, 150 rpm, 200 rpm, 250 rpm and 300 rpm.

III. RESULTS & DISCUSSION

From the experiment, the output is in form of graphs (displacement, torque, force, vibration and speed) versus time (Fig. 6), and the raw data is about the 60000 data for every single experiment. Figure below show mode output data while doing experiment with input 100 rpm.

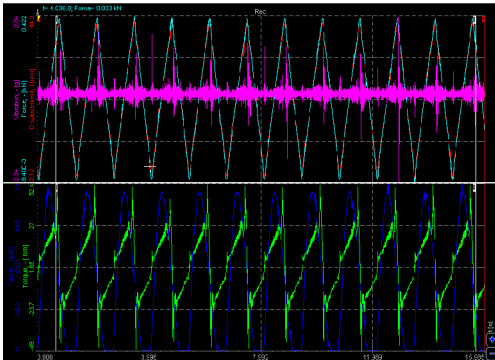

Figure 6. Graphs of output data of 100 rpm for one complete cycle

The data gathered can be interpreted due to kinematics analysis, which meaning that, the data can be reconstructed in form of displacement, velocity and acceleration analysis. For that, the data for one cycle of cam rotation ($\beta = 360^\circ$) was determined.

Fig. 7 shows the displacement diagram, velocity diagram, and acceleration diagram, after reconstructed of the output data for one complete cycle of the experiment using speed of 100 rpm.

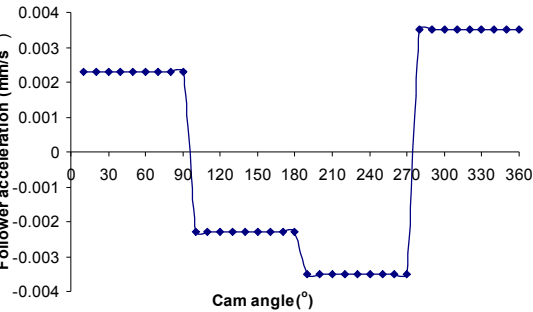
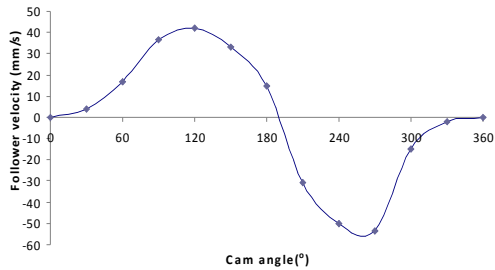
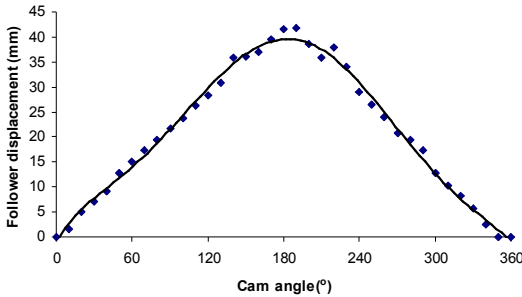

Figure 7. Follower displacement, velocity diagram (b) and acceleration diagram (c) versus cam angle at 100 rpm

For other input value (100 rpm, 150 rpm, 200 rpm, 250 rpm and 300 rpm), its show same pattern of graph. In the follower displacement graphs, they have same value and same pattern graph of the diagram. The differences among the input value are the maximum value of velocity and acceleration that has change constantly with the change of speed of the cam. For this shape of cam, the maximum value of displacement, velocity and acceleration are summarized in the Table 1 according to the input value.

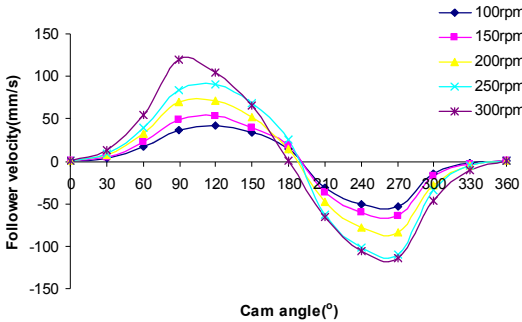

Figure 8. Follower velocity diagram in 5 different speeds

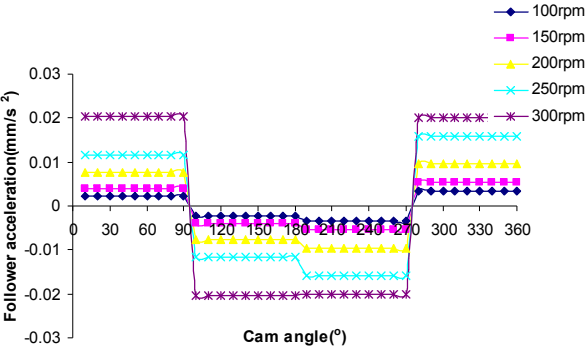

Figure 9. Follower acceleration diagram in 5 different speeds.

Fig. 8 shows the velocity of the follower rose gradually from 0° to 90° before it constantly went down until 270°. The velocity of the follower increased again constantly until 360°. Here, it shows that when the speeds increase, it will also increase the velocity of the cam and the follower system.

In contrast with the follower acceleration diagram (Fig. 9), the acceleration of the follower remained stable from 0° to 90° before it rapidly went down to the negative value from 90° to 270°. After that, the acceleration of the follower increased rapidly until 360°. The figure also shows same trend that when the system undergoes the high speed application, the acceleration of the cam and the follower system will increase. Also, it can increase the vibration of the system. Increasing in vibration will affect the system due to rapid wear and the system will collapse for the certain time.

Table 1. Maximum values for experimental method

Speed (rpm)	Displacement (mm)	Velocity (mm/s)	Acceleration (mm/s ²)
100	41.6	53.59	0.0023
150	41.6	64.06	0.0040
200	41.6	83.71	0.0077
250	41.6	109.33	0.0116
300	41.6	114.06	0.0203

Cam profile analysis

From Fig. 10, it shows a little difference between graphical method and experimental method. It may occur when reconstruction of cam profile between actual cam compare to experimental data. But from analysis, it shows the small different between actual cam and experimental data of construction cam.

From comparison between graphical and experimental methods, the different of instantaneous follower displacement can be calculated and shows the small value of displacement occur among them (less than 5 %).

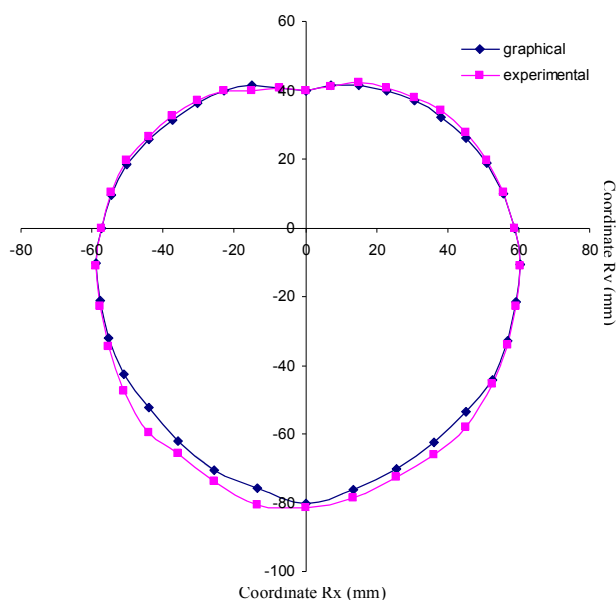

Figure 10. Comparison of cam profile between graphical and experimental methods

Table 2. Error occur during the experiment compare to graphical methods

Speed (rpm)	Displacement (%)	Velocity (%)	Acceleration (%)
100	4.00	4.40	3.14
150	4.83	30.20	79.37
200	4.65	50.45	99.23
250	3.43	77.78	404.34
300	4.90	98	782.60

The detail of the percentage errors between graphical and experimental methods had been summarized in the Table 2. Overall, the error occurs during the low speed application is smaller than during high speed application.

IV. CONCLUSION

In conclusion, this project attempts to study the kinematics analysis of heart cam shape in 3 parameters; follower displacement, follower velocity and follower acceleration. The cam profile shows that the rise quadrant is from 0° to 180°, fall quadrant is from 180° to 360° of the cam mechanism system.

Comparison between graphical and experimental methods of cam mechanism show that the error occurs in many type of parameter using in the analysis. From this analysis, the displacement error between graphical and experimental method is around 3.43% ~ 4.90%. It shows that whatever error is small or not, it still has an error because of many aspects that interrupt while doing experiment. The velocity error between graphical and experimental method is 4.40% and the acceleration error between graphical and experimental method is 3.14%. The error will increase while the speeds of the cam mechanism increase.

The error occurs between low speed application and high speed application show that when this shape of cam used for low speed, it endure low follower velocity and low follower acceleration, that cause little bit of vibration. But when this shape of cam having a high speed application, it endure the large external force, used to be in high velocity and high acceleration of cam, that cause high vibration not only to the cam and follower, but to the whole system. When the system operating at 100 rpm, it only show the low percentage of error (velocity error = 4.40 % and acceleration error = 3.14 %), but when operating at 300 rpm, it show very high percentage of error (velocity error = 98 % and acceleration error = 782.60 %). Therefore, this shape of heart cam shape is only suitable for low speed application, because it show the unbalance system when operating in high speed. It must endure the rapid ware due to high vibrations when operating in high speed application.

ACKNOWLEDGMENT

The authors would like to express their thanks to the Universiti Malaysia Pahang for funding this project.

REFERENCES

- [1] Zhang Y., Finger S. and Behrens S., (2006), Rapid Design through Virtual and Physical Prototyping, Carnegie Mellon University.
- [2] Erdman A.G. and Sandor G.N., (1964), Mechanism Design: Analysis and Synthesis Vol. 1, Prentice Hall, New Jersey.

- [3] Chen F. Y., (1982), Mechanics and Design of Cam Mechanisms, Pergamon Press, New York.
- [4] Myszka D.H., (2005), Machines & Mechanisms, Pearson Prentice Hall, Third Edition, New Jersey.
- [5] Jensen P. W., (1987), Cam Design and Manufacture 2nd ed, Marcel Dekker Inc.
- [6] Lee R. S. and She C. H., (1998). Tool path Generation and Error Control Method for Multi Axis NC machining of Spatial Cam. International Journal Machine Tools Manufacturing. 38 (4) 277-290.
- [7] Rothbart, H.A., (2005), Cam Design Handbook. McGraw-Hill Handbooks, New York.