

RAIN-WATER PLC BASED DETECTOR AND VALVE SWITCHER

MOHAMMAD HADI BIN ISMAIL

This thesis is submitted as partial fulfillment of the requirements for the award of
the
Bachelor Degree of Electrical Engineering (Electronics)

Faculty of Electrical & Electronics Engineering
University Malaysia Pahang

MAY, 2008

“I hereby acknowledge that the scope and quality of this thesis is qualified for
theaward of the
Bachelor’s Degree of Electrical Engineering (Electronics)”

Signature : _____

Name : IR ZULKEFLEE BIN KHALIDIN

Date :

“All the trademark and copyrights use herein are property of their respective owner. References of information from other sources are quoted accordingly; otherwise the information presented in this report is solely work of the author.”

Signature : _____

Author : MOHAMMAD HADI BIN ISMAIL

Date : 6 May 2008

To my beloved parents....
who always pray for me and give me courage to finish this thesis.

Also, to those people who have guided and inspired me throughout my journey.

Thank you for the supports and advices that have been given...

ACKNOWLEDGEMENT

In the name of Allah S.W.T, the Most Gracious, the Ever Merciful. Praise is to Allah, Lord of the Universe and Peace and Prayers be upon His final Prophet Muhammad s.a.w.

I would like to take this opportunity to sincerely express my highest gratitude to my supervisor Mr. IR Zulkeflee Bin Khalidin for his guidance, ideas and advice from the started till the project is done.

Secondly, I would also like to thank for all other University Malaysia Pahang staff members that I may have called upon for assistance since the genesis of this project. Their opinions and suggestions have helped me in realizing this project. Also not to be forgotten, I would like to thank for all my friends with the support, valuable help and sharing ideas during the progress of this project.

Finally, special thanks expressed to my beloved father and mother who are always by my side supporting me with love, moral and money. Not to forget my brother who is always encourages me to complete this project.

ABSTRACT

The main purpose of this project is to collect clean rain water automatically by using water sensor; solenoid valves, buzzer and water pump that controlled by Programmable Logic Controller (PLC). Below is modeling of the project.

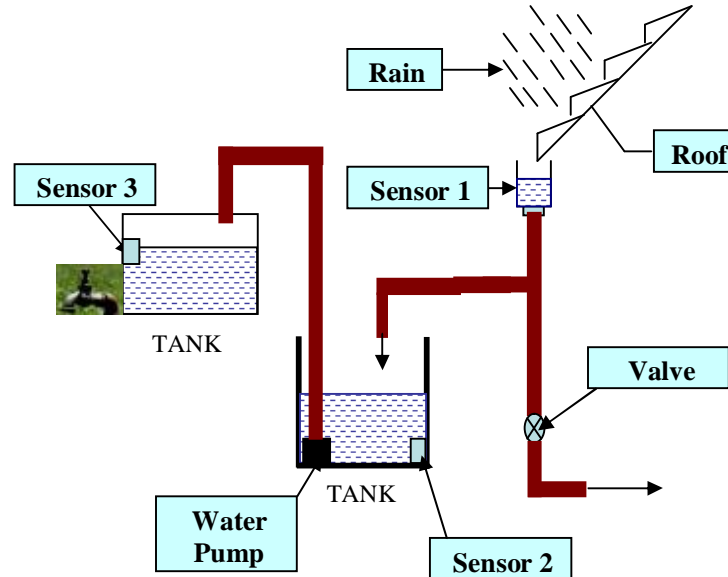

When rain fall, sensor 1 will be detect water and make cause valve 1 will be open for 10 second. This is because; we need to flow out the dirty water from the roof firstly. After 10 second, the valve will be close and make cause the rain water will go to the tank A. If sensor 3 detect no water, water from tank A will be pump to the tank B, with condition, sensor 2 must be detect water in tank A firstly. Finally we can use rain water from Tank B for useful purpose like flushing toilets, washing machines, watering gardens, washing cars and etc.

ABSTRAK

Tujuan utama projek ini ada untuk mengumpulkan air hujan yang bersih secara automatik dengan menggunakan pengesan air, pili selonoid, penggera dan pam air yang dikawal oleh Pengawalan Logik Program (PLC). Rajah dibawah menunjukkan gambarajah projek tersebut:-

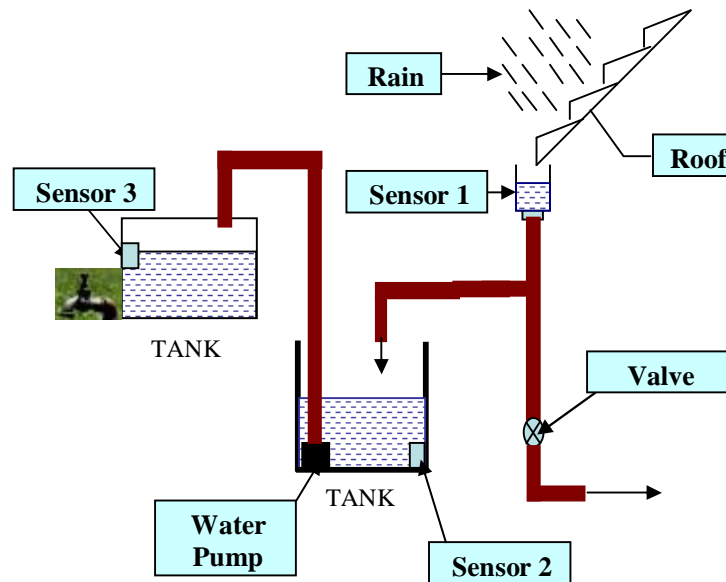

Apabila hujan turun, pengesan air 1 akan mengesan air hujan dan menyebabkan pili 1 akan terbuka untuk 10 saat. Ini adalah kerana air hujan yang kotor akan dikeluarkan terlebih dahulu. Selapas 10 saat, pili air akan ditutup dan menyebabkan air hujan tadi akan mengalir ke tangki A. Jika pengesan air 3 tidak mengesan air, air dari tangki A akan dipam ke Tangki B, dengan syarat, pengesan air 2 mesti mengesan air di Tangki A terlebih dahulu. Akhir sekali, air hujan yang telah dikumpul di Tangki B boleh digunakan untuk kegunaan harian seperti tangki air tandas, membasuh kain, pertanian, membasuh kereta dan lain-lain.

TABLE OF CONTENTS

CHAPTER	TITLE	PAGE
	ACKNOWLEDGEMENT	vii
	ABSTRACT	viii
	ABSTRAK	viii
	TABLE OF CONTENTS	x
	LIST OF FIGURES	vii
1	INTRODUCTION	
	1.1 Project Background	1
	1.2 Problem Statement	2
	1.3 Objective of Project	3
	1.4 Scope of Project	3
	1.5 Methodology	4
	1.6 Review Of Thesis Content	6
2	LITERATURE REVIEW	
	2.1 Introduction	7
	2.2 Rainwater Harvesting System Overview	7
	2.2.1 Roof	7
	2.2.2 PVC Gutter	8
	2.2.3 Down pipes	8
	2.2.4 Storage Tank	8
	2.2.5 Overflow Pipe	8

2.3 Programmable Logic Controllers (PLC)	
2.3.1 Introduction	9
2.3.2 Digital and Analog signals	9
2.4 Switcher Valve	
2.4.1 Introduction	13
2.4.2 Construction	13
2.4.3 Direct Acting 2 Way Valves	14
2.5 Water Pump	
2.5.1 Introduction	15
2.5.2 Water Pump System	15
2.6 Water Level & Rain Sensor	
2.6.1 Introduction	16

3

SYSTEM DESIGN

3.1 Introduction	17
3.2 Literature Review	18
3.3 Roof	18
3.4 Theoretical Design	19
3.5 Hardware Development	19
3.6 Software Development	20

4

RESULT & DISCUSSION

4.1 Introduction	21
4.2 Rainwater And Water Level Sensor Detector	22
4.3 The Concept of The Water Sensor Circuit	26
4.4 OMRON Programmable Logic Controllers	29
4.5 Valve	34
4.6 Water Pump	36
4.7 Programming Design	38
4.8 Costing And Commercialized	43

5

CONCLUSION & RECOMMENDATION

5.1 Conclusion	44
5.2 Future Recommendations	44

REFERENCES	45
-------------------	----

APPENDICES

APPENDIX A (Datasheet of 555 TIMER)	46
APPENDIX B (PLC)	56
APPENDIX C (MOTOR PUMP)	78
APPENDIX D (RELAY)	82
APPENDIX E CX-PROGRAMMER	87
APPENDIX F (PICTURE)	94

CHAPTER 1

INTRODUCTION

1.1 Project Background

Everyday we used mains water to supply all our water needs is needlessly wasteful, both financially and environmentally. Mains water is expensively purified to drinking water standards but much of the water is used for non-potable purposes, like flushing toilets, cleaning and gardening. Harvested rainwater can be substituted for mains water, saving money and contributing to the protection of a key natural resource. The idea of collecting rainwater has been around for thousands of years. Archaeologists have found that rainwater harvesting systems were being used in the Negev desert 4000 years ago. In Ancient Rome villas had their own individual cisterns and the rainwater was collected from paved courtyards which made them less reliant on the supply fed by the city's aqueducts. Today around the world rainwater harvesting is enjoying a renaissance and systems are being extensively installed for domestic, commercial and industrial use.

Rainwater is particularly useful to supply the large volume of water needed for flushing toilets. Each person on average uses almost 45 liters a day for this purpose. In an average household, this contaminates nearly 66,000 liters of drinking water a year. This is the main use of water in a household, closely followed by bathing and washing which uses 37 liters per person per day.

Rainwater is ideal for use in washing machines; on average people use 20 litres a day for washing clothes. The advantage is that the soft rainwater allows the use of natural soaps and biological washing powders, which are much more gentle on clothes than standard detergents.

Gardeners through the centuries have recognized the importance of a plentiful supply of water, and that plants prefer natural rainwater instead of heavily treated mains water. Rainwater can also be used for car washing and other general cleaning tasks around the home. The use of rainwater can really come into its own in business and industry. Not only is water extensively used in a wide range of tasks, but there are often large roof and hard standing areas to catch rainwater. This provides an incentive to invest in rainwater harvesting equipment as business use can offer a relatively short pay-back period. In large offices and public buildings, rainwater can be used for flushing toilets and urinals and for cleaning.

1.2 Problem Statement

Many people want to harvest rainwater to fill their tank. But they need to open the cap of tank to allow rainwater flow to the tank. So, rainwater PLC based water detector and valve switcher is a system to open and close valve automatically when rain is fall. Hence the user will not go to tank just want to open the cap.

1.3 Project Objectives

The Objectives of this project are:-

- 1.3.1 To develop the hardware and software by using PLC (Programmable Logic Controller) and as a main controller.
- 1.3.2 To open switcher valve when the sensor detect rainwater to allow dirty rainwater flow out firstly before fulfill Tank A.
- 1.3.3 To Control water level between Tank A and Tank B.
- 1.3.4 To develop rain water and water level sensor circuit.

1.4 Project Scope

The scope of this project is:-

- 1.4.1 PLC (Programmable Logic Controller) as main controller.
- 1.4.2 Constructing rainwater detection sensor circuit by using 555 timer IC.
- 1.4.3 Controlling Switcher Valve to flow out the dirty rainwater for 10 second.
- 1.4.4 Controlling Water level between Tank A and Tank B so that there were have same level water.

1.5 Methodology

There were some method was taken to make sure the flow of the project is smooth and can be done according to due date. There were two steps that must be taken to done this project. It is:-

- 1.5.1 do studies on hardware that needed in this project such as PLC, Water detection sensor and switcher valve.
- 1.5.2 Design a model to show the flow of the water.
- 1.5.3 Do studies on the available software that can be program on PLC to control the valve.

Figure 1.1 showed the methodology or work flow of the project that have been used as the guideline in order to do the project. In started with investigate the topic and objectives with supervisor. After doing literature review, equipment that needed was investigated like water detection sensor, PLC and valve. In the same time, programming was designed to control the system.

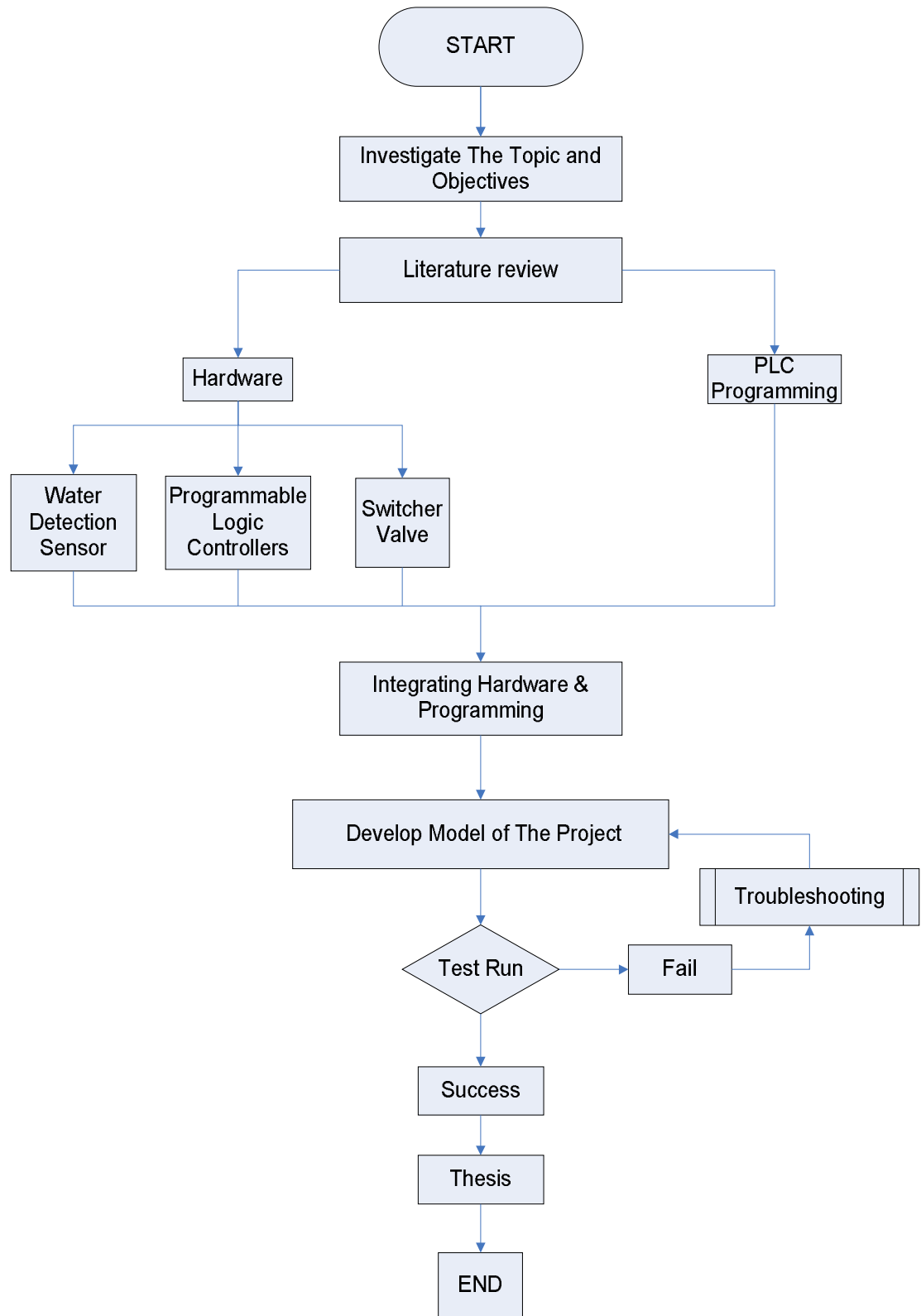

FIGURE 1.1 THE WORK FLOW OF THE PROJECT.

1.6 Review of Thesis Contents.

This thesis had six contents. Chapter 1 discusses about background of the project, problem statement, project objectives, scope of project and methodology.

Chapter 2 provides a literature review about water harvesting that many use by people in the world today. In this chapter, also discussing about characteristics of water detection sensor, PLC and switcher electronic valve that usually used in industry.

Chapter 3 focuses on the methods system architecture that is used for this project including all essential modules of the system. It also discusses on hardware and programming used for this project. For hardware, there were divided into several parts like hardware design module and programming development module.

Chapter 4 discusses all about the design system of the project. The explanation begin with applying the idea into action, using the hardware that has been choose, applying the programming that control the system and lastly combine all component into one perfect system.

Chapter 5 will be outcomes from the project which will be consist of figure of the hardware project and other related stuff.

Chapter 6 will be include the summary of the project where it will conclude overall of the project and recommendation for future development.

CHAPTER 2

LITERATURE REVIEW

2.1 INTRODUCTION

On this chapter, some literature reviews have been done on several resources. The theories and description have taken as guidance in completing this project. So this chapter will present and overview the equipment that needed in this project.

2.2 RAINWATER HARVESTING SYSTEM OVERVIEW

2.2.1 ROOF

The existing roof is made use of to collect rainwater. Since rainwater is pure as it falls from the sky it is necessary that the roof be kept clean for it to remain pure when it is collected. This means the roof will need to be swept and cleaned daily during the rainy season in the district.

2.2.2 PVC GUTTERS

The gutters of PVC collect the rainwater from the roof and transfer it to the filter by controlled by valve to open and close. On sloping roofs, PVC gutters can pick up leaves, dust, small twigs and other organic matter. The gutters need to be cleaned regularly at least weekly once. During the rainy season the PVC gutters should be inspected and cleaned daily.

2.2.3 DOWNPIPES

PVC down pipes brings the water from the rainwater gutters or pipes vertically down. They should invariably be clamped firmly to the wall and should never be loosely fixed.

2.2.4 STORAGE TANK

The rainwater **storage tank** collects all the rainwater and keeps it for future use. The storage tank is made above the ground and on a platform. It can also be an underground sump in some cases.

2.2.5 OVERFLOW PIPE

The storage tank will have an overflow pipe from the top of the tank. In case of heavy rain, the overflow pipe will allow the excess rain water to be safely disposed of without causing any flooding.

2.3 PROGRAMMABLE LOGIC CONTROLLERS (PLC)

2.3.1 Introduction

A *programmable logic controller (PLC)* is a specialized computer used to control machines and processes. It uses a programmable memory to store instructions and execute specific functions that include on/off control, timing, counting, sequencing, arithmetic, and data handling.

Initially the PLC was used to replace relay logic, but its ever-increasing range of functions means that it is found in many and more complex applications. Because the structure of a PLC is based on the same principles as those employed in computer architecture, it is capable not only of performing relay switching tasks but also of performing other applications such as counting, calculating, comparing, and the processing of analog signals.

2.3.2 Digital and analog signals

Digital or discrete signals behave as binary switches, yielding simply an On or Off signal (1 or 0, True or False, respectively). Pushbuttons, limit switches, and photoelectric sensors are examples of devices providing a discrete signal. Discrete signals are sent using either voltage or current, where a specific range is designated as *On* and another as *Off*.

For example, a PLC might use 24 V DC I/O, with values above 22 V DC representing *On*, values below 2VDC representing *Off*, and intermediate values undefined. Initially, PLCs had only discrete I/O.

Analog signals are like volume controls, with a range of values between zero and full-scale. These are typically interpreted as integer values (counts) by the PLC, with various ranges of accuracy depending on the device and the number of bits available to store the data. As PLCs typically use 16-bit signed binary processors, the integer values are limited between -32,768 and +32,767. Pressure, temperature, flow, and weight are often represented by analog signals. Analog signals can use voltage or current with a magnitude proportional to the value of the process signal. For example, an analog 4-20 mA or 0 - 10 V input would be converted into an integer value of 0 - 32767.

An analog output could send a 4 to 20 milliamp signal to a variable-speed drive. The drive will control the speed of a motor in proportion to analog signal received from the analog output module.

Figure below showed the valve position correlation to the module's output voltage.

ANALOG SIGNAL COMPARISON FOR SAMPLE ANALOG VALUE OUTPUT		
Valve Position	Voltage Ouput Signal	Decimal Valve Output to Output Section
FULL OPEN	10	32,767
80%	8	26,214
70%	7	22,937
60%	6	19,660
50%	5	16,384
40%	4	13,107
30%	3	9,830
20%	2	6,553
10%	1	3,276
Closed	0	0

Figure 2.1 Valve position correlation to the module's output voltage.

In addition to cost savings, PLCs provide much other benefit including:-

i) **Increased reliability**

Once a program has been written and tested, it can be easily downloaded to other PLCs. Since all the logic is contained in the PLC's memory, there is no chance of making a logic wiring error. PLC's also offer the reliability associated with solid-state components.

ii) **More Flexibility**

It is easier to create and change a program in a PLC than to wire and rewired a circuit. Originally equipment manufacturers can provide system updates by simply sending out a new program.

iii) **Lower Cost**

PLC were originally designed to replace relay control logic, and the cost savings have been so significant that relay control is becoming obsolete except for power application.

iv) **Communications Capability**

A PLC can communicate with other controllers or computer equipment to perform such functions as supervisory control, data gathering, monitoring devices and process parameters, and download and upload of programs.

v) **Faster Response Time**

PLCs are designed for high-speed and real-time applications. The programmable controller operates in real time, which means that an event taking place in the field will result in the execution of an operation or output.

vi) **Easier to troubleshoot**

PLCs have resident diagnostics and override functions that allow users to easily trace and correct software and hardware problems. [1] (Frank D. Petruzella, 2005)

Many types of PLC are available such as Omron, Mitsubishi, Siemen, Nais and many more. In this project, I am using Omron PLC which has 3 inputs and 2 outputs. This PLC is suitable to control the switching of valve and speed of motor pump.

2.4 SWITCHER VALVE

2.4.1 Introduction

A solenoid valve is a device that regulates the flow of substances (either gases, fluidized solids, slurries, or liquids) by opening, closing, or partially obstructing various passageways. Valves are technically pipe fittings, but usually are discussed separately.

Solenoid valves are used wherever fluid flow has to be controlled automatically. They are being used to an increasing degree in the most varied types of plants and equipment. The variety of different designs which are available enables a valve to be selected to specifically suit the application in question.

Valves are used in a variety of applications including industrial, military, commercial, residential, and transportation. Plumbing valves are the most obvious in everyday life, but many more are used.

2.4.2 Construction

Solenoid valves are control units which, when electrically energized or de-energized, either shut off or allow fluid flow. The actuator takes the form of an electromagnet. When energized, a magnetic field builds up which pulls a plunger or pivoted armature against the action of a spring. When de-energized, the plunger or pivoted armature is returned to its original position by the spring action.

2.4.3 Direct-Acting 2-Way Valves