

Flowering of strict photoperiodic *Nicotiana* varieties in non-inductive conditions by transgenic approaches

Petr Smykal · Jérôme Gennen · Stefanie De Bodt · Venkatesh Ranganath · Siegbert Melzer

Received: 23 April 2007 / Accepted: 16 July 2007 / Published online: 28 July 2007
© Springer Science+Business Media B.V. 2007

Abstract The genus *Nicotiana* contains species and varieties that respond differently to photoperiod for flowering time control as day-neutral, short-day and long-day plants. In classical photoperiodism studies, these varieties have been widely used to analyse the physiological nature for floral induction by day length. Since key regulators for flowering time control by day length have been identified in *Arabidopsis thaliana* by molecular genetic studies, it was intriguing to analyse how closely related plants in the *Nicotiana* genus with opposite photoperiodic requirements respond to certain flowering time regulators. *SUPPRESSOR OF OVEREXPRESSION OF CONSTANS 1* (*SOC1*) and *FRUITFULL* (*FUL*) are two MADS box genes that are involved in the regulation of flowering time in *Arabidopsis*. *SOC1* is a central flowering time pathway integrator, whereas the exact role of *FUL* for floral induction has not been established yet. The putative *Nicotiana* orthologs of *SOC1* and *FUL*, *NtSOC1* and *NtFUL*, were studied in day-neutral tobacco *Nicotiana tabacum* cv Hicks, in short-day

tobacco *N. tabacum* cv Hicks Maryland Mammoth (MM) and long-day *N. sylvestris* plants. Both genes were similarly expressed under short- and long-day conditions in day-neutral and short-day tobaccos, but showed a different expression pattern in *N. sylvestris*. Overexpression of *NtSOC1* and *NtFUL* caused flowering either in strict short-day (*NtSOC1*) or long-day (*NtFUL*) *Nicotiana* varieties under non-inductive photoperiods, indicating that these genes might be limiting for floral induction under non-inductive conditions in different *Nicotiana* varieties.

Keywords *Nicotiana* · Floral induction · MADS box genes · *TobMADS* · *NtSOC1* · *NtFUL*

Introduction

Plants have adapted flowering time for their natural habitats and, therefore, the onset of flowering varies widely among different species and ecotypes. Temperature and day length are the principal environmental cues for plants to track the seasons of the year, which allow flowering to be synchronised for maximum reproductive success. Since the discovery of photoperiodism in soybean and Maryland Mammoth tobacco plants by Garner and Allard (1920), numerous experimental approaches in different plant species have been undertaken in order to study the day-length-dependent flowering in a large variety of photoperiodic plants (Thomas and Vince-Prue 1997). These classical studies, however, were limited in their ability to identify the underlying molecular nature for flowering time control in long- and short-day plants.

In recent years, rapid progress has been made in understanding the molecular mechanisms of floral induction in *Arabidopsis thaliana*, a facultative long-day plant

P. Smykal · S. Melzer
Institute of Plant Sciences, ETH Zürich, Universitaetstrasse 2,
8092, Zurich, Switzerland

Present Address:
P. Smykal
Department of Biotechnology, AGRITEC Plant Research Ltd.,
Zemedelska 2520/16, 78701, Sumperk, Czech Republic

J. Gennen · S. De Bodt · S. Melzer (✉)
Department of Plant Systems Biology, Flanders Interuniversity
Institute for Biotechnology, Ghent University, Technologiepark
927, 9052, Ghent, Belgium
e-mail: siegbert.melzer@psb.ugent.be

V. Ranganath
The Wellcome Trust Sanger Institute, Wellcome Trust Genome
Campus, Hinxton, Cambridge, CB10 1SA, UK

and, more recently, in rice (*Oryza sativa*), a short-day plant (reviewed in Searle and Coupland 2004). In *Arabidopsis* four main pathways that control flowering time have been defined genetically. The photoperiod and the vernalisation pathways are involved in the perception of environmental signals, whereas the autonomous pathway acts independently of environmental cues (Koornneef et al. 1998; Mouradov et al. 2002; Simpson and Dean 2002). Gibberellins (GAs) are limiting for flowering in *Arabidopsis* (Wilson et al. 1992) and by genetic analysis of double mutant combinations of GA and late-flowering mutants the promotion of flowering by GAs has been shown to be mediated by a fourth independent pathway (Reeves and Coupland 2001). These flowering time pathways converge on pathway integrators, such as LEAFY (LFY) (Blazquez and Weigel 2000), FT (Kardailsky et al. 1999; Kobayashi et al. 1999) and the MADS box protein SOC1 (Borner et al. 2000; Lee et al. 2000; Samach et al. 2000). *CONSTANS* (*CO*) encodes a zinc finger protein that is a central regulator for flowering time control in *Arabidopsis* by long days. *CO* is expressed in the vasculature where it directly activates *FT* transcription (An et al. 2004). The FT protein has been shown to be transported to apical meristems (Corbesier et al. 2007; Tamaki et al. 2007), where it interacts with FD (Abe et al. 2005; Wigge et al. 2005) to activate *SOC1* expression (Searle et al. 2006), which finally leads to the activation of floral meristem identity genes and the formation of flowers.

In *Sinapis alba* (mustard) plants, the *SOC1* ortholog, *SaMADSA*, is co-expressed with the *FUL* ortholog, *SaMADSB*, in apical meristems and procambial strands during floral transition (Menzel et al. 1996) and in a genome-wide expression analysis, *SOC1* and *FUL* have been found to be similarly up-regulated in response to photoperiodic floral induction in apical meristems in *Arabidopsis* (Schmid et al. 2003). *FUL* was originally identified as a regulator for fruit dehiscence (Ferrández et al. 2000b; Gu et al. 1998), but mutant analysis indicated that it also plays a role in flowering time control (Ferrández et al. 2000a; S. Melzer, unpublished data). Molecular studies have shown that *FUL* expression is controlled in part by *FT* (Teper-Bamnolker and Samach 2005), but the role of *FUL* for floral induction in *Arabidopsis* is not clear yet.

Nicotiana species and cultivars have different photoperiodic requirements for flowering time control and have been used for many decades in floral induction studies (Lang 1989; McDaniel 1996). These studies have indicated that identical flowering stimulatory and inhibitory substances are formed in different photoperiodic response types under inductive or non-inductive conditions, whereas classical grafting experiments have revealed that these substances can be transferred from one response type to another (Lang 1989). However, molecular and genetic

studies of flowering time control are still limited in *Nicotiana* species. In an attempt to understand whether the same mechanism controlling flowering time might exist in species of the same genus with different photoperiodic requirements, we studied flowering time responses in *Nicotiana* varieties by overexpressing genes that play a central role in *Arabidopsis* for floral induction. In this work, we characterised the tobacco orthologs of *SOC1* and *FUL*, *NtSOC1* and *NtFUL*. Furthermore, transgenic plants were made that constitutively expressed either *NtSOC1* or *NtFUL* in day-neutral cv Hicks tobacco, strict long-day *N. sylvestris* and the short-day MM cv Hicks tobacco. The MM cv Hicks tobacco was established by introgressing the recessive Maryland Mammoth gene into *N. tabacum* cv Hicks through backcrossing with the short-day MM cultivar (Gebhardt and McDaniel 1991).

Overexpression of *NtSOC1* and *NtFUL* caused very early flowering in day-neutral tobacco, and under inductive photoperiods also in the short-day variety MM cv Hicks and in long-day *N. sylvestris* plants. However, under non-inductive conditions the transgenic lines behaved differently. The *35S::NtSOC1* transgene bypassed the photoperiodic requirements in the MM cv Hicks tobacco, but not in long-day *N. sylvestris* plants under non-inductive conditions. Conversely, the *35S::NtFUL* transgene triggered flowering of *N. sylvestris* under non-inductive short days, but had no effect in MM cv Hicks tobacco in long days, suggesting that these genes are limiting in certain *Nicotiana* varieties under non-inductive conditions.

Materials and methods

Plant material and growth conditions

Seeds from *Nicotiana tabacum* cv. Hicks, *N. tabacum* MM cv Hicks and *N. sylvestris* plants were obtained from Dr Susan Singer (Carleton College, Northfield, MN, USA) and were sown on soil. Seedlings were singled out in 16-cm pots after 21 days. Plants were grown either in phytotrons under short-day (8 h light) and long-day conditions (16 h light), under fluorescent tubes emitting a photon flux density of $160 \mu\text{mol m}^{-2} \text{s}^{-1}$ at 20°C, or in greenhouses in long days at 22°C during the day and 18°C during the night.

Isolation and characterisation of *SaMADSA/SOC1* and *SaMADSB/FUL* tobacco orthologs

To identify tobacco orthologs to mustard and *Arabidopsis* *SaMADSA/SOC1* and *SaMADSB/FUL* genes, cDNA libraries were constructed from RNA of florally induced apices derived from *N. tabacum* cv Hicks plants with

standard protocols. A λ gt10 library with 5,000,000 plaque forming units (pfu) were screened at low stringency (hybridisation at 45°C and washing in 1× SSC, 0.2% SDS at 37°C) with *Hind*III fragments of *SaMADSA* and *SaMADSB* that did not contain the MADS domain (Menzel et al. 1996). Positive pfu were purified, phage DNA was isolated and *Eco*RI-digested with fragments subcloned into a pBluescript SK⁺ vector (Stratagene, Madison, WI, USA). Ten cross-hybridising clones for each gene were selected and sequenced.

The *SOC1* and *FUL* homologous sequences of *Arabidopsis thaliana* (*At*), *Sinapis alba* (*Sa*), *Petunia x hybrida* (*Ph*), *Lycopersicon esculentum* (*Le*), *N. tabaccum* (*Nt*) and *N. sylvestris* (*Ns*) were extracted from the NCBI database (<http://www.ncbi.nlm.nih.gov>). Protein sequences were aligned with ClustalW (Thompson et al. 1994), and the alignment was edited with BioEdit (URL: <http://www.mbio.ncsu.edu/BioEdit/bioedit.html>), resulting in an alignment of the conserved residues of the MADS, I and K domain. Neighbour-Joining (Saitou and Nei 1987) trees for the proteins were constructed with TREECON (Van de Peer and De Wachter 1997) based on Poisson-corrected distances. To assess support for the inferred relationships, 500 bootstrap samples (Felsenstein 1985) were generated.

Transgene construction and plant transformation

By using primers with *Eco*RI adaptors, the coding regions of *NtSOC1* and *NtFUL* were amplified by standard PCR reactions and fused to the CaMV 35S promoter in pRT101 plasmids (Töpfer et al. 1987). The expression cassette of the pRT101 vector was introduced as a *Hind*III fragment into pRD400 (Datla et al. 1992) and the binary vector was transformed into the *Agrobacterium tumefaciens* strain C58C1. For *Agrobacterium*-mediated leaf disc transformation (Horsch et al. 1985), day-neutral *N. tabacum* cv. Hicks, *N. tabacum* MM cv Hicks and *N. sylvestris* plants were grown in vitro. Regenerating plants were selected on agar plates containing Murashige and Skoog (MS) media (Duchefa, Haarlem, The Netherlands) supplemented with 500 mg/l Timenten and 200 mg/l kanamycin. Seeds from T1 and T2 plants were tested for homozygosity on kanamycin plates and T3 or T4 homozygous lines were used for experiments.

RNA blot and semi-quantitative RT-PCR analysis

Total RNA was isolated according to Melzer et al. (1990). For transgene expression analyses, 30 μ g of total RNA from seedlings was separated on formaldehyde agarose gels, transferred to nylon membranes and hybridised with *NtSOC1* or *NtFUL* probes, without the MADS box region, at 65°C according to standard protocols.

For a semi-quantitative RT-PCR analysis, reverse transcription of 3 μ g of total RNA was performed with SuperScript II RT (Invitrogen, Carlsbad, CA, USA) as described (Melzer et al. 1999). Gene-specific PCR products were amplified with the following primer pairs: for 5'-*NtSOC1*: GCATGCGGCAGCAAGTTTGAT; for 3'-*NtSOC1*: GGAAAATATAATACACATCC; for 5'-*NtFUL*: GGGGAAAGCATATCAGAGTAC; for 3'-*NtFUL*: CAAGGCTGATAAAGATCAG; for 5'-*NtNAPI-2*: CCTCCTACAACCACATCCAT; for 3'-*NtNAPI-2*: TAGGAAATTACATTCTCA; for 5'-*NtNFI*: CAAGAAGATGAGTGAATATTAACGA and for 3'-*NtNFI*: CAGTTACAGAA TTTGCAGAACTGAAT. Semi-quantitative PCR was performed at 58°C annealing temperature for 20 or 25 cycles. The PCR fragments were gel separated, transferred to nylon membranes and hybridised with their corresponding probes. As a control, tobacco *eIF4A10* transcripts (Mandel et al. 1995) were amplified with 5'-*NteIF4A10* CAATTGCTACCACCAAAGAT and 3'-*NteIF4A10* AAAGGAGATCGGCCACATTGG primers.

Microscopy

For microscopic analysis, samples were fixed overnight with 4% formaldehyde in 50 mM phosphate buffer, pH 7, dehydrated with EtOH and embedded in Technovit 7100 resin (Heraeus Kulzer, Wetzlar, Germany). Sections of 6 μ m were cut with a rotary microtome, stained with phloroglucinol/HCL to visualize lignified cells and mounted in DePex medium (British Drug House, UK).

Results

Identification of *SOC1* and *FUL* orthologs in tobacco

Since *SOC1* and *FUL* in *Arabidopsis* as well as the mustard orthologs, *SaMADSA* and *SaMADSB*, have similar expression patterns, both in apical meristems and in procambial strands of the developing inflorescence after floral induction (Borner et al. 2000; Menzel et al. 1996), we analysed the orthologs of both genes in strict photoperiodic tobacco plants. To identify putative *SOC1/SaMADSA* and *FUL/SaMADSB* orthologs in tobacco, we screened a *N. tabacum* cDNA library, which was made from mRNA of apical buds from induced plants, under low-stringency conditions with mustard *SaMADSA* and *SaMADSB* probes. Probes without the conserved MADS box regions hybridised to several phage plaques from which 10 were selected for further characterisation. All clones that cross-hybridised with *SaMADSA* were identical to the previously identified *TobMADSI* gene (Mandel et al. 1994; X76188), which

showed a high sequence homology to *SOC1* and *SaMADSA*, indicating that this is the *SOC1* ortholog of tobacco. Therefore, for more clarity, this gene was re-designated to *NtSOC1*. From cDNAs showing cross-hybridisation with *SaMADSB*, three were identical to *NtNAP1-1* and its homolog *NsMADS1* in *N. sylvestris* (Wu et al. 2000). Seven other cDNAs were identical, had a higher amino acid identity to *SaMADSB* and *FUL* and were subsequently designated *NtFUL* (GenBank: DQ534202).

Phylogenetic relationships of *NtSOC1* and *NtFUL*

NtSOC1 (CAA53782) belongs to the TM3 (TDR3-X60756) subfamily of MADS-box proteins, of which *SOC1/AGL20* (AAG16297) and *SaMADSA* (AAB41526) are the *Arabidopsis* and mustard representatives, respectively (Borner et al. 2000; Samach et al. 2000). Based on the phylogenetic tree of the closest *SOC1* homologs, we can conclude that *NtSOC1* is most closely related to the petunia (*Petunia hybrida*) FBP21 protein (AAK21252). The petunia FBP20 or UNSHAVEN (UNS) protein (AAK21252) (Ferrario et al. 2004) also belongs to this subfamily, albeit it is not directly related to the tobacco *NtSOC1* protein (Fig. 1A).

NtFUL (ABF82231) belongs to the SQUAMOSA (SQUA) (X63701) subfamily and is closely related to the *Arabidopsis* *FUL* (NM_125484) and mustard *SaMADSB* (U25695) proteins (Fig. 1B). The *FUL* clade has undergone a duplication in the *Solanaceae* lineage (Litt and Irish 2003) and the tobacco protein described here belongs to the clade of the tomato (*Lycopersicon esculentum*) *TDR4* (X60757) and the *PETUNIA FLOWERING GENE* (PFG) (AF176782) (Immink et al. 1999) proteins, whereas *NtNAP1-1* (AAD01421) and *NsMADS1* (AF068725) (Wu et al. 2000) belong to the clade of *LeFUL2* (AY306156) and *PhFBP26* (AAF19164) (Fig. 1B).

Expression analysis of *NtSOC1* and *NtFUL*

Expression of *NtSOC1* and *NtFUL* in roots, stems and leaves of *N. tabacum* plants was analysed by semi-

Fig. 1 Phylogenetic relationships of *NtSOC1* and *NtFUL*. The phylogenetic trees of *NtSOC1* (A) and *NtFUL* (B) are based on protein sequences. The scale represents the evolutionary distance, with 0.1 substitutions per site

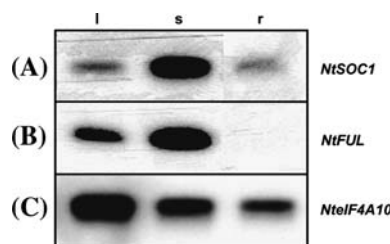
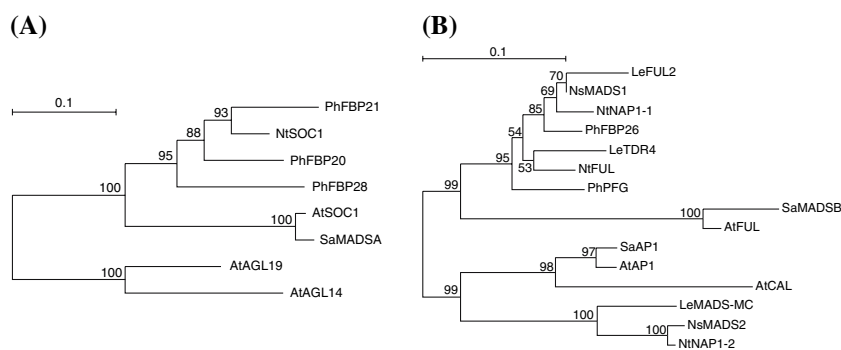

Fig. 2 Expression analysis of *NtSOC1* and *NtFUL* in different tissues. RT-PCR was performed on samples from leaves (l), upper internodes of stems without the apex (s) and roots (r) from 6-week-old vegetative plants with either *NtSOC1* (A) or *NtFUL* (B) primer pairs. As a control fragments of tobacco *eIF4A10* cDNAs were amplified (C)

quantitative RT-PCR. As shown in Fig. 2, both genes were detectable in leaves with 20 cycles of RT-PCR and at higher levels in stems of 9-week-old vegetative plants grown under long days. *NtSOC1* was also visible at low levels in roots, in which we did not see any transcript accumulation of *NtFUL*. *SOC1* and *FUL* are both expressed during vegetative stages in *Arabidopsis* plants, but are dramatically up-regulated in apical meristems after floral induction (Borner et al. 2000; Mandel et al. 1995; Schmid et al. 2003). Therefore, we analysed by semi-quantitative RT-PCR whether *NtSOC1* and *NtFUL* might also be developmentally regulated in apices of different *Nicotiana* varieties, grown for 3, 6, 9, and 12 weeks either under short- or long-day conditions. Until 9 weeks after sowing, all *Nicotiana* plants examined remained vegetative, but the 12-week-old plants grown under inductive conditions had started flower development. Expression profiles of *NtSOC1* and *NtFUL* as well as that of the *APETALA1* (*API*) ortholog *NtMADS5* (Calonje et al. 2004) and that of one of the *Nicotiana FLORICAULA* (*FLO*) *LEAFY* (*LFY*) orthologs, *NFL1* (Kelly et al. 1995), were compared from apices of day-neutral tobacco, short-day cv Hicks MM tobacco and long-day *N. sylvestris* plants (Fig. 3). The *NtSOC1* and *NtFUL* expression levels were very low in apical buds of day-neutral tobacco plants and short-day cv Hicks MM plants grown for 3 weeks in short- and long-day regimes. The expression levels increased similarly in apical buds of both tobacco varieties under short photoperiods to high

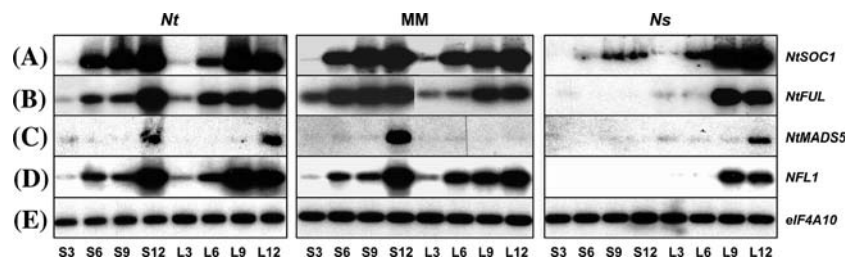

Fig. 3 Development-dependent expression of *NiSOC1* and *NtFUL* in apices of different *Nicotiana* varieties. A semi-quantitative RT-PCR was performed with RNA from apices of plants grown for 3, 6, 9 or 12 weeks under short (S3–S12) or long days (L3–L12) with *NiSOC1*

primers on samples from *N. tabacum* cv. Hicks (*Nt*), *N. tabacum* cv. Hicks MM (MM) and *N. sylvestris* plants (*Ns*). Amplification of *N. sylvestris* *eIF4A10* is shown as an internal control for the expression in *N. sylvestris* (E) levels in 12-week-old plants. In long days, transcript levels of both genes increased also continuously with age, but compared to *NiSOC1*, *NtFUL* mRNA accumulated at lower levels in apices of vegetative MM cv. Hicks plants. However, both genes were expressed under these non-inductive conditions. We observed a different expression pattern in long-day *N. sylvestris* plants: expression of both genes was not detectable in non-inductive short days 3 weeks after sowing. Whereas *NiSOC1* mRNA accumulated to very low levels, *NtFUL* was undetectable throughout further development in short days. Under long-day conditions, both genes were expressed at low levels during the early stages of development and mRNA levels gradually increased to high levels after 9 and 12 weeks from sowing (Fig. 3A, B).

NiMADS5 could not be detected above background in apical buds of all vegetative stages, except at very basal levels in *N. sylvestris* in long days, but increased to high levels at stages in which all *Nicotiana* varieties had undergone the floral transition (Fig. 3C). Transcripts of *NFL1* were already visible in apical buds of vegetative stages in day-neutral and short-day tobacco plants. The expression levels increased during subsequent stages to high levels in 12-week-old plants. In *N. sylvestris*, expression of *NFL1* was not observed in apical buds of plants grown under non-inductive short days. In long days, expression of *NFL1* was first detectable in 9-week-old plants at a level similar to that in 12-week-old plants (Fig. 3D).

Modulation of flowering time by constitutive expression of *NiSOC1* or *NtFUL*

Constitutive expression of *SOC1* and *FUL1* in the facultative long-day plant *Arabidopsis* shortened drastically the vegetative phase and caused a photoperiod-independent flowering (Borner et al. 2000; S. Melzer, unpublished result). To analyse whether the orthologous *NiSOC1* and *NtFUL* transgenes might also modulate flowering time in transgenic *Nicotiana* plants, we introduced the coding regions of *NiSOC1* and *NtFUL* under the control of the strong cauliflower mosaic virus 35S promoter into *N. tabacum* cv Hicks, *N. tabacum* MM cv Hicks and

N. sylvestris plants. We obtained several independent transgenic lines either expressing the *NiSOC1* or the *NtFUL* transgene. Five transgenic lines of day-neutral tobacco and 10 transgenic lines each from MM cv Hicks and *N. sylvestris* with each transgene were studied in detail. All lines had very high transgene expression levels compared to those of the endogenous genes (Fig. 4).

Since the number of leaf nodes can be used to analyse flowering time in tobacco plants (McDaniel 1996), we compared different genotypes by counting leaf numbers. The *NiSOC1* and *NtFUL* transgenes promoted flowering in each transgenic line under inductive photoperiods (Fig. 5A–E). Day-neutral cv Hicks tobacco wild-type plants flowered after the production of 25 leaves under long days (Fig. 5E, *Nt*), whereas the different transgenic 35S::*NiSOC1* tobacco lines flowered after forming 14–22 leaves (Fig. 5E, T1-1 to T1-5). The transgenic 35S::*NtFUL* tobacco lines started flowering later after forming 18–22 leaves (Fig. 5E, T2-1 to T2-5). In short days, the wild-type tobacco plants flowered earlier than under long days after forming 18 leaves and the transgenic lines flowered again earlier after the initiation of 9–14 (35S::*NiSOC1*) or 12–16 (35S::*NtFUL*) leaves (Fig. 5E).

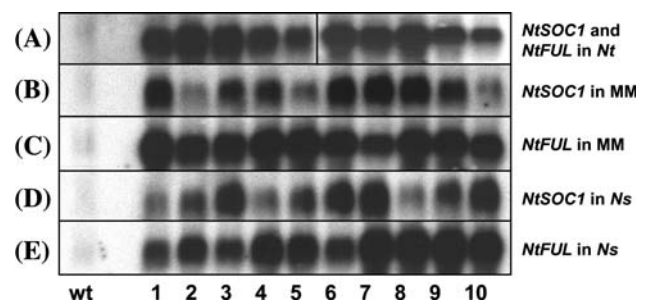
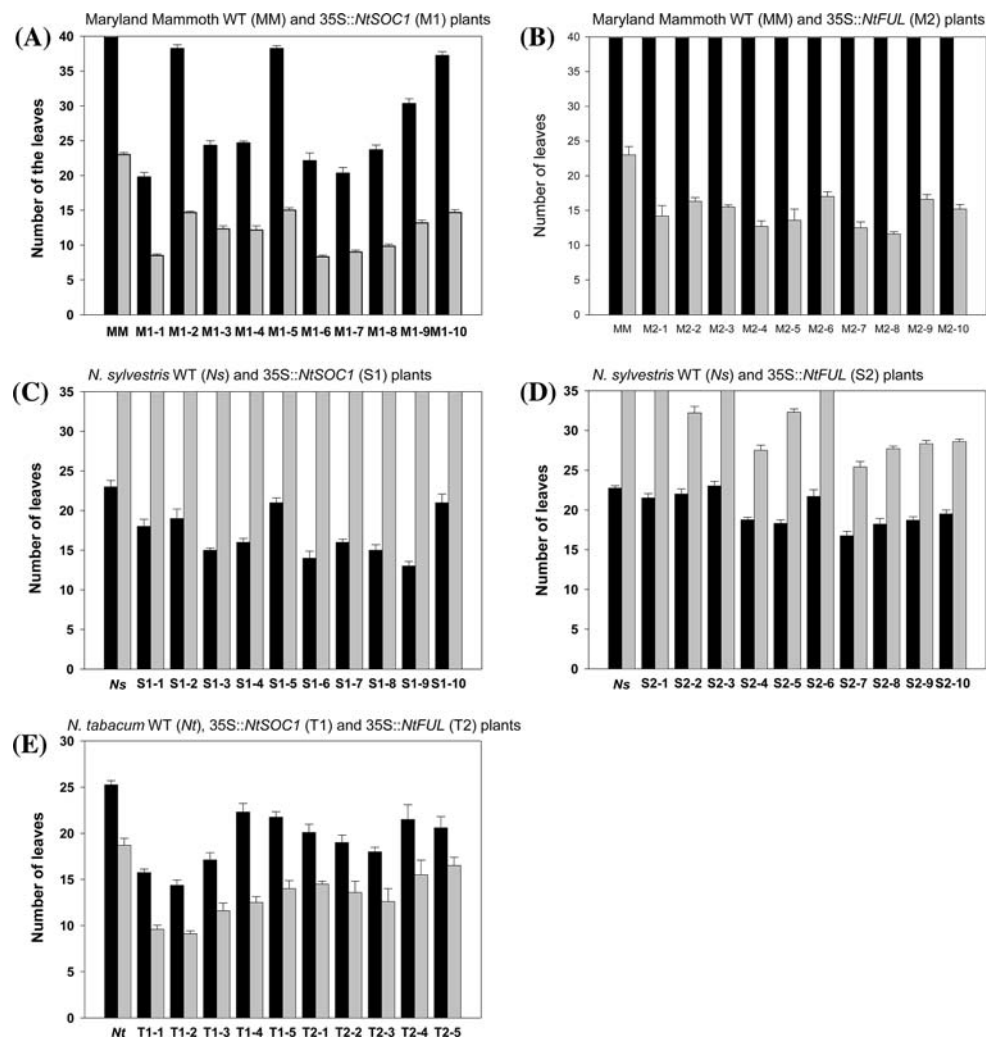

Fig. 4 Expression levels of 35S::*NiSOC1* and 35S::*NtFUL* in different *Nicotiana* varieties. (A) Expression level of 35S::*NiSOC1* (left) and 35S::*NtFUL* (right) transgenes in five analysed lines each from *N. tabacum* cv. Hicks. (B) *N. tabacum* MM cv. Hicks wild-type plants and 10 transgenic lines overexpressing 35S::*NiSOC1*. (C) *N. tabacum* MM cv. Hicks wild-type and 10 transgenic lines overexpressing 35S::*NtFUL*. (D) *N. sylvestris* wild-type plants and 10 transgenic lines overexpressing 35S::*NiSOC1*. (E) *N. sylvestris* wild-type plants and 10 transgenic lines overexpressing 35S::*NtFUL*

Fig. 5 Flowering time analysis of transgenic *Nicotiana* plants overexpressing *NtSOC1* or *NtFUL*. Comparison of leaf numbers of wild-type and different transgenic *Nicotiana* lines grown either under long (black bars) or under short days (grey bars). **(A)** *N. tabacum* cv. Hicks MM wild-type (MM) and transgenic plants overexpressing 35S::*NtSOC1* (M1-1 to M1-10). **(B)** *N. tabacum* cv. Hicks MM wild-type (MM) and transgenic plants overexpressing 35S::*NtFUL* (M2-1 to M2-10). **(C)** *N. sylvestris* wild-type (*Ns*) and transgenic plants (S1-1 to S1-10) overexpressing 35S::*NtSOC1*. **(D)** *N. sylvestris* wild-type (*Ns*) and transgenic plants (S2-1 to S2-10) overexpressing 35S::*NtFUL*. **(E)** *N. tabacum* WT (*Nt*) and transgenic plants (T1-1 to T1-5 for 35S::*NtSOC1* and T2-1 to T2-5 for 35S::*NtFUL* lines). Bars reaching the top of the graphs, without an error bar, represent plants that did not flower under the particular conditions



Nicotiana tabacum MM cv Hicks wild-type plants had a short initial rosette stage under inductive short days and flowered after forming 23 leaves, whereas the transgenic lines overexpressing *NtSOC1* had no initial rosette stage (Fig. 6A) and flowered after forming 8–15 leaves (Fig. 5A, M1-1 to M1-10). *N. tabacum* MM cv Hicks wild-type plants never flowered under our experimental conditions in long days. However, all 35S::*NtSOC1* lines flowered under non-inductive conditions after the formation of 20–38 leaves (Figs. 6B and 5A, M1-1 to M1-10). Transgenic MM cv Hicks lines overexpressing *NtFUL* also flowered earlier under inductive short days after forming 12–17 leaves, but these transgenic lines never flowered in non-inductive long days (Fig. 5B, M2-1 to M2-10). *N. sylvestris* plants overexpressing 35S::*NtSOC1* had no initial rosette stage and flowered earlier under inductive long days (Fig. 6C). The leaf number was reduced from 23 in wild-type plants (Fig. 5C, *Ns*) to 13–21 leaves in the transgenic lines (Fig. 5C, S1-1 to S1-10). Under non-inductive short days, wild-type *N. sylvestris* plants remained for up to 9 months in the rosette stage before senescing, whereas the

transgenic lines overexpressing *NtSOC1* bolted after a short initial rosette stage, but did not flower under these conditions (Fig. 6H). In addition to flowering time effects, we also observed some other pleiotropic phenotypes in transgenic lines overexpressing *NtSOC1*. In *N. sylvestris* lines with strong transgene expression, leaves were fused at the base (Fig. 6E), which was never observed in transgenic tobacco or MM cv Hicks plants, indicating that the *NtSOC1* transgene interferes with processes in the apical meristem of vegetative *N. sylvestris* plants. In all transgenic lines of the different *Nicotiana* varieties overexpressing *NtSOC1*, floral structures were also affected. Flowers had a longer style, which consequently raised the stigma above the anthers and prevented self-pollination (Fig. 6F). In addition to the longer style, the pods developed on twisted petioles that were 10–15 mm long (Fig. 6G). *N. sylvestris* plants overexpressing 35S::*NtFUL* (lines S2-1 to 2-10) flowered after 17–22 leaves had been formed, only a bit earlier than the wild-type *N. sylvestris* plants under inductive long days (Fig. 5D, S2-1 to S2-10). However, seven 35S::*NtFUL* transgenic lines with strong transgene expression levels

Fig. 6 Phenotypes of transgenic *Nicotiana* plants overexpressing *NtSOC1* or *NtFUL*. **(A)** Wild-type MM plant (left) flowered later than a 35S::*NtSOC1* MM plant (right) under short days. **(B)** Under long days, MM wild-type plants (left) never flowered, whereas the 35S::*NtSOC1* MM plant (right) flowered. **(C)** *N. sylvestris* plant overexpressing *NtFUL* (right) flowered earlier than control plants (left) under inductive long days. **(D)** *N. sylvestris* 35S::*NtFUL* plants (right) overcame the photoperiodic barrier for flowering in short days. **(E)** *N. sylvestris* 35S::*NtSOC1* plant showing laminar connections of subsequent leaves. **(F)** *N. tabacum* flowers overexpressing 35S::*NtSOC1* (right) had shorter tubes and longer styles than wild type plants (left). **(G)** The capsules of *N. tabacum* 35S::*NtSOC1* plants sitting on a petiole (right), absent in wild-type plants. **(H)** In short days, *N. sylvestris* 35S::*NtSOC1* plants (right) started to bolt, but did not flower under these non-inductive conditions as the *N. sylvestris* wild-type plants (left)

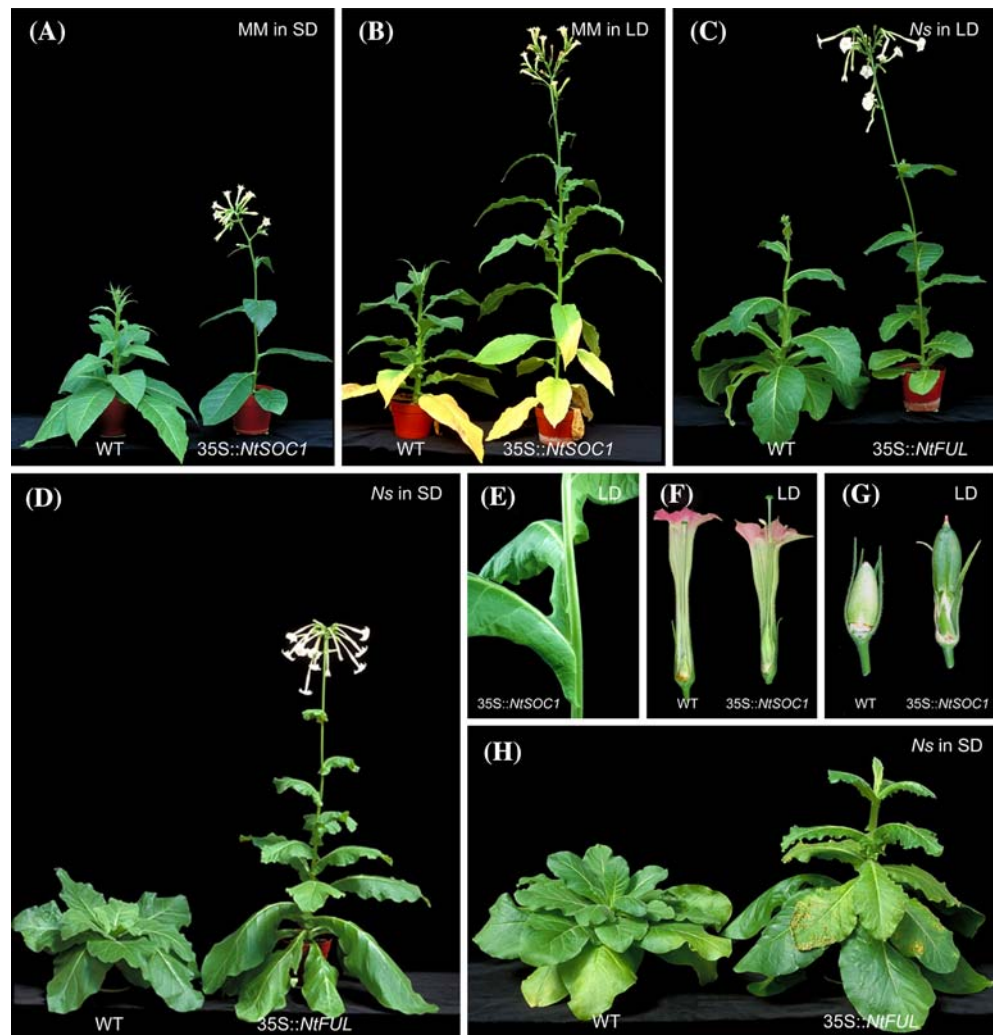

actually flowered under otherwise non-inductive short-day conditions (Figs. 5D, 6D).

Constitutive expression of *NtFUL* prevents seed dehiscence in transgenic *Nicotiana* plants

Constitutive expression of *FUL* in *Arabidopsis* has been shown to prevent seed dispersal. Since the orthologous gene also might have the same function in *Nicotiana* plants, we analysed whether transgenic lines overexpressing *NtFUL* were altered in fruit opening. Capsules of wild-type *Nicotiana* plants open at maturity from the top (Fig. 7A) and the seeds are dispersed from the capsules by slight movements. However, the capsules of plants overexpressing *NtFUL* remained closed (Fig. 7B) and had alterations at the cellular level. As seen in Fig. 7C, D, the amount of lignified cells and the degree of lignification at the midrib of a carpel was higher in wild-type plants (Fig. 7C) than that of a transgenic line (Fig. 7D). Together with a larger incision in wild-type plants, physical forces of the drying capsule had created

tissue tensions that easily opened the pods, whereas those of the transgenic lines remained closed. This phenotype strongly indicates that *NtFUL* from tobacco is a true orthologs of *FUL* in *Arabidopsis*.

Discussion

The developmental switch to flowering has been studied intensively in different model plants over the last decades. However, only in the last 15 years molecular-genetic studies in *Arabidopsis* have shown that complex networks of genetic pathways converge on integrators to control the transition to reproductive growth. Triple mutants with mutations in key genes of the autonomous, photoperiodic and GA pathways, such as the *fca co gal* triple mutant, do not flower (Reeves and Coupland 2001), whereas triple *lfy ft soc1* integrator mutants still do (Moon et al. 2005), implying that other genes might act in parallel. *SOC1* and *FUL* have a similar expression pattern during the transition to flowering in apical meristems (Borner et al. 2000;

Fig. 7 Altered pod dehiscence in transgenic *N. sylvestris* plants overexpressing *NtFUL* in long days. (A) Open capsule of a *N. sylvestris* wild-type plant. (B) Closed capsule of a *N. sylvestris* 35S::*FUL* plant. (C) Section through the midrib of a *N. sylvestris* wild-type carpel. (D) Section through the midrib of a *N. sylvestris* 35S::*FUL* carpel

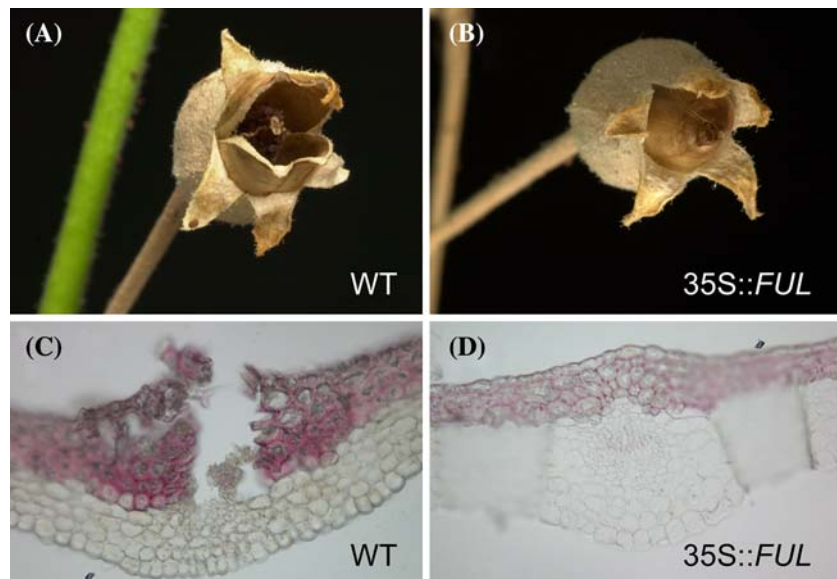

Mandel and Yanofsky 1995) and their proteins interact (de Folter et al. 2005), suggesting that *FUL* might also represent an important factor downstream of flowering time pathways. Therefore, it was intriguing to analyse whether the orthologous genes of *SOC1* and *FUL* also act as flowering time regulators in *Nicotiana* varieties. We identified and characterised the putative orthologs, *NtSOC1* and *NtFUL* from tobacco that were highly expressed in stems of non-flowering plants. Since in situ hybridisations in mustard have revealed that the orthologs, *SaMADSA* and *SaMADSB* are expressed in procambial strands and in inflorescence stem veins (Menzel et al. 1996), these genes as well as *NtSOC1* and *NtFUL* in *Nicotiana* species might also have a physiological function there.

In cv Hicks and MM cv Hicks tobacco plants, expression of *NtSOC1* and *NtFUL* was already observable in vegetative stages under long and short days and the expression increased to high levels until the plants flowered. In *N. sylvestris*, the expression patterns of both genes and that of *NFL1* were different from those in the tobacco varieties. The *SOC1* ortholog was weakly detectable from the 6th week on and increased only slightly during the following weeks in short days. However, no expression of the *NFL1* and *FUL* orthologous genes was detectable under non-inductive short days over the entire growth period, indicating that these genes might be limiting for flowering of *N. sylvestris* in short days.

Modulation of flowering time by *NtSOC1* and *NtFUL* in *Nicotiana* varieties

Overexpression of *NtSOC1* and *NtFUL* shortened the vegetative phase under inductive conditions in all

Nicotiana varieties (Fig. 6A, C), which is in accordance with observations in transgenic *Arabidopsis* plants overexpressing *SOC1* or *FUL* that flower dramatically earlier and independently of the photoperiod (Borner et al. 2000; S. Melzer, unpublished data). The spontaneous MM mutation transformed a day-neutral tobacco into a short-day tobacco, which had a great impact on the discovery of photoperiodism (Garner and Allard 1920). Previously, we have shown that the strict photoperiodic control of flowering in long days can also be bypassed in MM tobacco plants by overexpressing the mustard ortholog of *SOC1*, *MADSA* (Borner et al. 2000) and the *NtFPF1* gene (Smykal et al. 2004). Expression of *NtSOC1* and *NtFPF1* is not altered in the MM tobacco (Fig. 3B and Smykal et al. 2004), indicating that the expression of both genes is not under control of the gene, which in the mutated form leads to the short-day photoperiodic response. Overexpression of both genes can overcome the photoperiodic barrier under otherwise non-inductive long days in transgenic MM tobacco plants, implying that the mutation is also not acting downstream of both genes. For that reason, *NtSOC1* and *NtFPF1* might act in parallel to the blocked photoperiodic pathway and the ectopic expression induces flowering by activating downstream components for floral induction that are otherwise not activated under long days (Fig. 8). However, flowering of the transgenic plants overexpressing *NtSOC1* in long days seems to be contradictory to the observed expression of *NtSOC1* under these conditions. Due to the experimental setup, cells containing *NtSOC1* mRNAs could not be exactly identified. Therefore, it might be that the expression was restricted only to the small leaves, which have been collected together with the apical meristems, or that an expression in apical meristems was below a certain threshold that was reached then by the

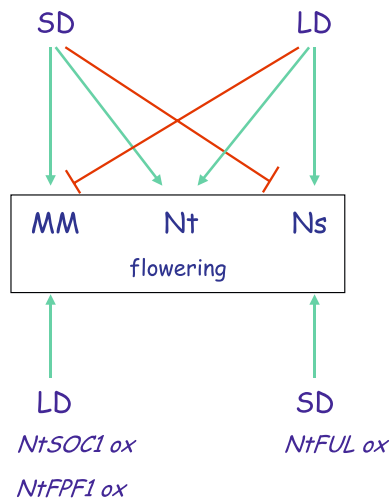

Fig. 8 Diagram for flowering in different *Nicotiana* varieties. *N. sylvestris* (*Ns*) and the MM tobacco flower only under long days or short days (green arrows), respectively, whereas the opposite conditions are inhibitory (red lines) and the day-neutral *N. tabacum* (*Nt*) flowers under both photoperiods. Overexpression of *NtSOC1ox* and *NtFPF1ox* caused flowering under non-inductive long days in the MM tobacco, but not in *N. sylvestris* under short days. Vice versa, overexpression of *NtFULox* leads to flowering in *N. sylvestris* under non-inductive short days, but not to flowering of transgenic MM plants in long days

overexpression of *NtSOC1*, which caused finally flowering under non-inductive long-day conditions.

The *FT* ortholog from tomato, *SINGLE FLOWER TRUST* (*SFT*), also bypassed the photoperiodic requirements of MM tobacco under non-inductive long days (Lifschitz et al. 2006) and the transgenic plants flowered even earlier than those overexpressing *NtSOC1* in both photoperiods. *FT* in *Arabidopsis* activates in addition to *SOC1* also *FUL* and *SEPALLATA3* (*SEP3*) expression (Abe et al. 2005; An et al. 2004; Schmidt et al. 2003; Teper-Bamnolker and Samach 2005; Wigge et al. 2005). Therefore, the activation of *FUL* and *SEP3* orthologs might also contribute to the earlier flowering phenotype of 35S::*SFT* MM tobacco plants. However, overexpression of *NtFUL* alone is not sufficient to induce flowering in the short-day MM tobacco under long days. Similarly, overexpression of *NtSOC1* and *NtFPF1* (Smykal et al. 2004) did not induce flowering in *N. sylvestris* under non-inductive short days. But on the contrary, constitutive expression of *NtFUL* caused flowering in *N. sylvestris* in short days, in which no expression of the *FUL* orthologs was observed (Fig. 3B), indicating that *FUL* is controlled by the photoperiodic pathway and is a limiting factor for flowering under non-inductive conditions. Most obviously, the earliest transgenic line overexpressing *NtFUL* (*S2-7*) flowered almost at the same time as did wild-type plants under long days and resembled a wild-type plant flowering under inductive conditions (Fig. 6D). The role of *FUL* for floral

induction in *Arabidopsis* has not been clarified yet. However, the fact that *FUL* is activated by *CO* and *FT* (Schmidt et al. 2003; Teper-Bamnolker and Samach 2005) and overexpression of *CO* in double mutants of *ful* and *soc1* greatly delays flowering compared to overexpression of *CO* in wild-type plants and single mutants (S. Melzer, unpublished results) argues for a specific and highly redundant role of *FUL* for the control of flowering by long days in *Arabidopsis* as well as in *N. sylvestris*.

Like in *Arabidopsis*, the *SOC1* ortholog might also act as a basic integrator in different *Nicotiana* varieties and might interact with other genes, such as *FUL*, to execute the signal-integrating function for certain flowering time pathways. Therefore, overexpression of *SOC1* alone might be not sufficient to overcome the photoperiodic barrier for flowering time control when other genes are limiting, as observed in *N. sylvestris* plants in short days, in which the *FUL* ortholog is not expressed. However, the data so far are also in line with the assumption that *NtSOC1* and *NtFUL* are specifically involved in two different pathways in photoperiodic *Nicotiana* varieties, which are not activated in non-inductive photoperiods, but can be activated or bypassed, by *NtSOC1* or *NtFUL* overexpression (Fig. 8). Therefore, our results indicate that the behaviour of long- and short-day *Nicotiana* varieties might differ in the requirement for certain MADS box genes to establish floral development in apical meristems after the arrival of the mobile flowering signal FT.

Acknowledgements We would like to thank Susann Singer for tobacco seeds, Klaus Apel, Tom Beeckman and Dirk Inzé for their generous support, Dieter Rubli and Karel Spruyt for taking pictures and Martine de Cock and Ryan Whitford for critical reading of the manuscript. S.D.B. is indebted to the Institute for the Promotion of Innovation by Science and Technology in Flanders (IWT) for a postdoctoral fellowship.

References

- Abe M, Kobayashi Y, Yamamoto S et al (2005) FD, a bZIP protein mediating signals from the floral pathway integrator FT at the shoot apex. *Science* 309:1052–1056
- An H, Roussot C, Suárez-López P et al (2004) CONSTANS acts in the phloem to regulate a systemic signal that induces photoperiodic flowering of *Arabidopsis*. *Development* 131:3615–3626
- Blazquez MA, Weigel D (2000) Integration of floral inductive signals in *Arabidopsis*. *Nature* 404:889–892
- Borner R, Kampmann G, Chandler J et al (2000) A MADS domain gene involved in the transition to flowering in *Arabidopsis*. *Plant J* 24:591–599
- Calonje M, Cubas P, Martínez-Zapater JM, Carmona MJ (2004) Floral meristem identity genes are expressed during tendril development in grapevine. *Plant Physiol* 135:1491–1501
- Corbesier L, Vincent C, Jang S et al (2007) FT protein movement contributes to long-distance signalling in floral induction of *Arabidopsis*. *Science* 316:1030–1033

- Datla RSS, Hammerlindl JK, Panchuk B, Pelcher LE, Keller W (1992) Modified binary plant transformation vectors with the wild-type gene encoding NPT II. *Gene* 211:383–384
- de Folter S, Immink RGH, Kieffer M et al (2005) Comprehensive interaction map of the *Arabidopsis* MADS box transcription factors. *Plant Cell* 17:1424–1433
- Felsenstein J (1985) Confidence limits on phylogenies: an approach using the bootstrap. *Evolution* 39:783–791
- Ferrández C, Gu Q, Martienssen R, Yanofsky M (2000a) Redundant regulation of meristems identity and plant architecture by, *FRUITFULL*, *APETALA1* and *CAULIFLOWER*. *Development* 127:725–734
- Ferrández C, Liljegren SJ, Yanofsky MF (2000b) Negative regulation of the *SHATTERPROOF* genes by *FRUITFULL* during *Arabidopsis* fruit development. *Science* 289:436–438
- Ferrario S, Busscher J, Franken J et al (2004) Ectopic expression of the *Petunia* MADS box gene *UNSHAVEN* accelerates flowering and confers leaf-like characteristics to floral organs in a dominant-negative manner. *Plant Cell* 16:1490–1505
- Garner WW, Allard HA (1920) Effect of the relative length of the day and night and other factors of the environment on growth and reproduction in plants. *J Agric Res* 18:553–606
- Gebhardt JS, McDaniel CN (1991) Flowering response of day-neutral and short-day cultivars of *Nicotiana tabacum* L. interactions among roots, genotype, leaf ontogenetic position and growth conditions. *Planta* 185:513–517
- Gu Q, Ferrández C, Yanofsky MF, Martienssen R (1998) The *FRUITFULL* MADS-box gene mediates cell differentiation during *Arabidopsis* fruit development. *Development* 125:1509–1517
- Horsch RB, Fry JE, Hoffmann NL et al (1985) A simple and general method for transferring genes into plants. *Science* 227:1229–1234
- Immink RGH, Hannapel DJ, Ferrario S et al (1999) A *petunia* MADS box gene involved in the transition from vegetative to reproductive development. *Development* 126:5117–5126
- Kardailsky I, Shukla VK, Ahn JH et al (1999) Activation tagging of the floral inducer *FT*. *Science* 286:1962–1965
- Kelly AJ, Bonnlander MB, Meeks-Wagner DR (1995) *NFL*, the tobacco homolog of *FLORICAULA* and *LEAFY*, is transcriptionally expressed in both vegetative and floral meristems. *Plant Cell* 7:225–234
- Kobayashi Y, Kaya H, Goto K, Iwabuchi M, Araki T (1999) A pair of related genes with antagonistic roles in mediating flowering signals. *Science* 286:1960–1962
- Koorneef M, Alonso-Blanco C, Peeters AJM, Soppe W (1998) Genetic control of flowering time in *Arabidopsis*. *Annu Rev Plant Physiol* 49:345–370
- Lang A (1989) *Nicotiana*. In: Halevy AH (ed) *Handbook of flowering*, vol VI. CRC Press, Boca Raton
- Lee H, Suh SS, Park E et al (2000) The *AGAMOUS-LIKE 20* MADS domain protein integrates floral inductive pathways in *Arabidopsis*. *Genes Dev* 14:2366–2376
- Lifschitz E, Eviatar T, Rozman A et al (2006) The tomato *FT* ortholog triggers systemic signals that regulate growth and flowering and substitute for diverse environmental stimuli. *Proc Natl Acad Sci USA* 103:6398–6403
- Litt A, Irish VF (2003) Duplication and diversification in the *APETALA1/FRUITFULL* floral homeotic gene lineage: implications for the evolution of floral development. *Genetics* 165:821–833
- Mandel MA, Yanofsky MF (1995) The *Arabidopsis AGL8* MADS box gene is expressed in inflorescence meristems and is negatively regulated by *APETALA1*. *Plant Cell* 7:1736–1771
- Mandel T, Lutziger I, Kuhlemeier C (1994) A ubiquitously expressed MADS-box gene from *Nicotiana tabacum*. *Plant Mol Biol* 25:319–321
- Mandel T, Fleming AJ, Krähenbühl R, Kuhlemeier C (1995) Definition of constitutive gene expression in plants: the translation initiation factor 4A gene as a model. *Plant Mol Biol* 29:995–1004
- McDaniel CN (1996) Developmental physiology of floral initiation in *Nicotiana tabacum* L. *J Exp Bot* 47:465–475
- Melzer S, Majewski DM, Apel K (1990) Early changes in gene expression during the transition from vegetative to generative growth in the long-day plant *Sinapis alba*. *Plant Cell* 2:953–961
- Melzer S, Kampmann G, Chandler J, Apel K (1999) PPF1 modulates the competence to flowering in *Arabidopsis*. *Plant J* 18:395–405
- Menzel G, Apel K, Melzer S (1996) Identification of two MADS box genes that are expressed in the apical meristem of the long-day plant *Sinapis alba* in transition to flowering. *Plant J* 9:399–408
- Moon J, Lee H, Kim M, Lee I (2005) Analysis of flowering pathway integrators in *Arabidopsis*. *Plant Cell Physiol* 46:292–299
- Mouradov A, Cremer F, Coupland G (2002) Control of flowering time: interacting pathways as a basis for diversity. *Plant Cell* 14:S111–S130
- Reeves PH, Coupland G (2001) Analysis of flowering time control in *Arabidopsis* by comparison of double and triple mutants. *Plant Physiol* 126:1085–1091
- Saitou N, Nei M (1987) The neighbour-joining method: a new method for constructing phylogenetic trees. *Mol Biol Evol* 4:406–425
- Samach A, Onouchi H, Gold SE et al (2000) Distinct roles of *CONSTANS* target genes in reproductive development of *Arabidopsis*. *Science* 288:1613–1616
- Schmid M, Uhlenhaut NH, Godard F et al (2003) Dissection of floral induction pathways using global expression analysis. *Development* 130:6001–6012
- Searle I, Coupland G (2004) Induction of flowering by seasonal changes in photoperiod. *EMBO J* 23:1217–1222
- Searle I, He Y, Turck F et al (2006) The transcription factor *FLC* confers a flowering response to vernalization by repressing meristem competence and systemic signaling in *Arabidopsis*. *Genes Dev* 20:898–912
- Simpson GG, Dean C (2002) *Arabidopsis*, the rosetta stone of flowering time. *Science* 296:285–289
- Smykal P, Gleissner R, Corbesier L, Apel K, Melzer S (2004) Modulation of flowering responses in different *Nicotiana* varieties. *Plant Mol Biol* 55:253–262
- Tamaki S, Matsuo S, Wong HL et al (2007) Hd3a protein is a mobile flowering signal in rice. *Science* 316:1033–1036
- Teper-Bamnolker P, Samach A (2005) The flowering integrator *FT* regulated *SEPALLATA3* and *FRUITFULL* accumulation in *Arabidopsis* leaves. *Plant Cell* 17:2661–2675
- Thomas B, Vince-Prue D (1997) *Photoperiodism in plants*. Academic Press, New York, NY
- Thompson JD, Higgins DG, Gibson TJ (1994) CLUSTAL W: improving the sensitivity of progressive multiple sequence alignment through sequence weighting, position-specific gap penalties and weight matrix choice. *Nucleic Acids Res* 22:4673–4680
- Töpfer R, Matzeit V, Gronenborn B, Schell J, Steinbiss HH (1987) A set of plant expression vectors for transcriptional and translational fusions. *Nucleic Acids Res* 15:5890
- Van de Peer Y, De Wachter Y (1997) TREECON for Windows: a software package for the construction and drawing of evolutionary trees for the Microsoft Windows environment. *Comput Appl Biosci* 10:569–570
- Wigge PA, Kim MC, Jaeger KE et al (2005) Integration of spatial and temporal information during floral induction in *Arabidopsis*. *Science* 309:1056–1059
- Wilson RN, Heckman JW, Somerville CR (1992) Gibberellin is required for flowering in *Arabidopsis thaliana* under short days. *Plant Physiol* 100:403–408
- Wu YY, Li Q, Zhang JS et al (2000) Molecular cloning and characterization of two tobacco MADS-box genes. *Sex Plant Reprod* 13:163–169