

Plant Soil (2011) 344:143–158
DOI 10.1007/s11104-011-0735-9

REGULAR ARTICLE

A consensus map of QTLs controlling the root length of maize

Andreas Hund · Regina Reimer · Rainer Messmer

Received: 21 June 2010 / Accepted: 20 January 2011 / Published online: 5 April 2011
© Springer Science+Business Media B.V. 2011

Abstract Traits related to the root length of maize (*Zea mays* L.), reported by 15 QTL studies of nine mapping populations, were subjected to a QTL meta-analysis. Traits were grouped according to ontology, and we propose a system of abbreviations to unambiguously identify the different root types and branching orders. The nine maps were merged into a consensus map, and the number and positions of putative QTL clusters (MQTLs) were determined. A total of 161 QTLs was grouped into 24 MQTLs and 16 individual QTLs. Seven MQTLs harbored root traits, which had been reported to be collocated with QTLs for grain yield or other drought-responsive traits in the field. The most consistent collocations were observed for the number and weight of the seminal roots (five loci). Based on our analysis at least six loci are good candidates for further evaluation (bins 1.07, 2.04, 2.08, 3.06, 6.05 and 7.04). For example, the MQTL in bin 2.04 harbored ten different single QTLs; the MQTLs in bins 1.07 and 3.06

combined 11 and 7 QTLs, respectively, that were detected in more than three populations. The presented database is a first step for a comprehensive overview of the genetic architecture of root system architecture and its ecophysiological function.

Keywords Consensus map · Meta-analysis · QTL · Roots · Root system architecture · *Zea mays* L.

Introduction

One of the central targets of trait-based crop research in this century is to increase the efficiency of the crop's root system. Having to provide food for a growing number of people requires energy-efficient cropping systems and better stewardship of limited soil resources, such as phosphorus and water. Many of these challenges can be tackled by improving the efficiency of root systems to acquire resources. However, more than 20 years ago, O'Toole and Bland (1987) noted that the improvement of crop root systems lagged behind that of aboveground plant traits. It may be argued that nothing has really changed since then, but the vision of efficient root systems remains strong. Roots are in the focus of Lynch's vision of a second Green Revolution to increase productivity in soils with suboptimal fertility (Lynch 2007). Considerable effort is being made to improve the phenotyping of root traits in such a way that they will become amenable to selection (Gregory

Responsible Editor: Peter J. Gregory.

Electronic supplementary material The online version of this article (doi:10.1007/s11104-011-0735-9) contains supplementary material, which is available to authorized users.

A. Hund (✉) · R. Reimer · R. Messmer
Institute of Agricultural Sciences, ETH Zurich,
8092 Zurich, Switzerland
e-mail: hundan@ethz.ch

et al. 2009; Hund et al. 2009b; Manschadi et al. 2008; Nagel et al. 2009; Yazdanbakhsh and Fisahn 2009). Some of these efforts are related to the questions of how an efficient root system looks like and how it responds to environmental stimuli. The answer to these questions depends on the target environment. For example, when water is limiting in a drying soil, deeper rooting may facilitate water uptake. Shallow rooting in contrast may facilitate foraging the topsoil for nutrients. Furthermore, the root system has to be capable of responding to a patchy distribution of nutrients in the soil and withstanding adverse conditions.

In order to compare root traits across experiments and developmental stages, it is necessary to employ an accurate, standardized nomenclature and to understand the relationships among the traits. The International Society of Root Research (ISRR, www.rootresearch.org) proposed a general nomenclature for roots (Zobel 2009; Zobel and Weisel 2010) to compare root types across species. The nomenclature suggested by Feix et al. (2000), which is used here, is probably the most common one for maize. It distinguishes four root types: primary, seminal, crown and prop roots, the latter also referred to as brace roots (Fig. 1) (Feix et al. 2000). The first two root types are embryonic as they develop during embryogenesis (Feldman 1994). The primary root forms at the basal pole of the embryo, while the seminal roots develop from the scutellar node. The internode between the scutellar node and the following first shoot node (coleoptilar node) is the mesocotyl. It elongates to lift the shoot base from the seed level up

to the soil surface. Nodal roots emerging from successive underground shoot nodes are termed crown roots. These roots become increasingly important for water and nutrient uptake during the later ontological development of the maize plant. Several orders of lateral roots, also termed branch roots, form successively on the parental axes of all four root types. In general, the diameter of lateral roots is less than 0.8 mm (McCully 1999). Accordingly, there are at least two ways to characterize the root system: i) according to the root type (primary, seminal and crown roots) and ii) according to the branching order (axile and lateral roots).

When comparing genotypes with regard to the organization of the embryonic root system, there is usually a striking difference between the lateral roots that emerge from the primary root and those that emerge from the seminal roots. For some genotypes, the lateral roots of the primary root can be considerably longer (up to 18 cm) than those of the seminal roots, which are usually about 3 cm long (Hund et al. 2007). Furthermore, the number of seminal roots can vary between 0 and 20 depending on the genotype (Kisselbach 1999; Sass 1977). Due to this variability of both the lateral branching of the primary root and the number of seminal axile roots, inbred lines can be distinguished according to the organization of their embryonic root system (Fig. 1a).

While the embryonic root system and its organization are the subject of an increasing number of studies, there are fewer studies of crown roots that develop later. However, since crown roots are by far the most

Fig. 1 Abbreviations used for the root types of maize. a) (primary (Pr), seminal (Se) crown (Cr) and prop (Pp) roots) as well as their branching order (axile (Ax) and lateral (Lat) roots) at the seedling stage (a) and at flowering (b). Plants of two contrasting inbred lines Lo964 (left) and Lo1016 (right) are shown in (a); Hund et al. 2004). Numbers in b indicate the node including the scutellar node (defined as node 0)

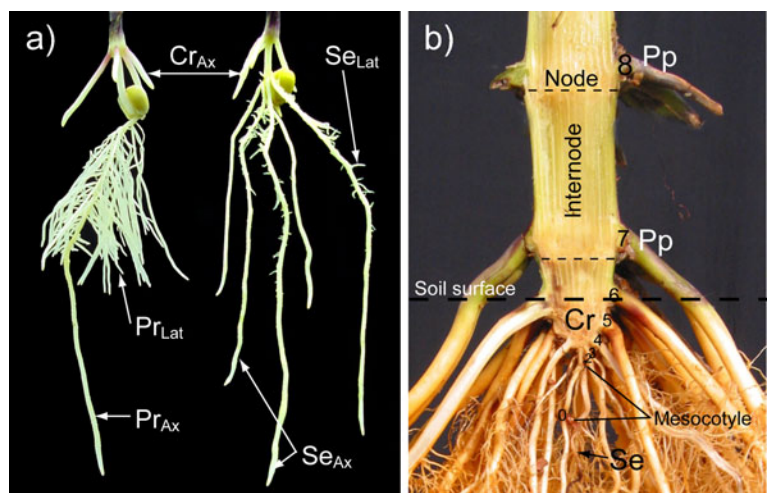

dominant root type of maize (Hoppe et al. 1986) and may be under a different genetic control than the embryonic roots (Feix et al. 2000; Hochholdinger 2008), they should not be neglected. Traits related to crown roots are usually measured in the field, mainly because of the space requirement of mature maize plants. For the sake of throughput, the examined traits are usually simple proxy measures for the size of the root system rather than very accurate quantifications of root system size and architecture. Examples for such proxy measures are: root pulling force (Landi et al. 2002; Lebreton et al. 1995), root capacitance (Messmer 2006; Van Beem et al. 1998), root number (Barrière et al. 2001; Guingo et al. 1998) and root angles (Barrière et al. 2001).

Root traits are the example *par excellence* for difficult-to-phenotype traits that may be modified by marker-assisted selection. As concluded by Hochholdinger and Tuberosa (2009): “the combination of novel genomic and phenomic tools will increase the knowledge about the association of root architecture and yield ... and will eventually assist breeders in developing superior maize hybrid via marker-assisted selection of key root features.” Marker-assisted selection of root traits proved to be successful in a scientific context: Molecular markers have been employed to isogenize root QTLs in maize to verify or clone them (Giuliani et al. 2009; Landi et al. 2009, 2010). Marker-assisted back-crossing was successfully used to transfer QTLs for root length in rice (Shen et al. 2001; Steele et al. 2006). In addition, the number of studies reporting QTLs for root traits is growing fast. Compiling these QTL results in meta-analyses will enhance our understanding of the genetic control of traits related to root architecture in maize beyond individual mapping populations.

The first meta-analysis for QTLs controlling root traits in maize was presented by Tuberosa et al. (2003). QTLs were collocated using a bin map on which each detected QTL was allocated to a genomic region (bin) defined by anchor markers (Gardiner et al. 1993). Although efficient, this approach was limited by the relatively coarse resolution of the bins. Alternatively, QTLs may be projected to a reference map, such as the IBM2 2008 Neighbors Frame (Schaeffer et al. 2008), to enable a comparison on a finer scale. Still, the question remains when to consider two QTLs as collocated. Furthermore, the straightforward projection of QTLs on a reference

map does not account for differences in family structure, sample size, marker number or QTL detection methods among studies. Alternatively, consensus maps can be constructed by considering the statistical properties of genetic distance estimates using the weighted least squares strategy (Veyrieras et al. 2007). Clustering algorithms allow grouping QTLs and projecting these meta-QTLs on a reference map. This approach was used to detect meta-QTLs for *Fusarium* head blight resistance of wheat (*Triticum aestivum* L.) (Loffler et al. 2009), for virus resistance of apricots (*Prunus armeniaca* L.) (Marandel et al. 2009) and root architecture in rice (*Oryza sativa* L.) (Courtois et al. 2009).

The aims of the present QTL meta-analysis in maize were: i) to summarize the literature on QTLs related to root length, ii) to describe the relationship among the different root components according to their ontology iii) to cluster the root QTLs and present them on a reference map and iv) to identify promising traits and loci for selecting efficient root systems.

Material and methods

Bibliographic review of traits related to root length

Fifteen published and two unpublished studies report QTLs related to root length in maize (*Zea mays* L.). These studies are based on nine QTL mapping populations. Only 15 studies provided enough information for a meta-analysis. These are ordered chronologically (ID) in Table 1. With regard to the origin of the map and the mapping populations, most studies refer to third-party origin. This was the case for the studies d1 and d2 (Tuberosa et al. 2002b), e1, e2 and e3 (Senior et al. 1996), f (Ma et al. 2007), g1 and g2 (Messmer et al. 2009), h1 and h2 (Fracheboud et al. 2002) and i (Keygene integrated map, Keygene NV, Wageningen, The Netherlands). All the mapping populations were designed to analyze the whole genome.

We considered the dry weight and the number of roots as traits that are related to root length. Moreover, root capacitance (study g2) was included in the meta-analysis since it correlated with root fresh mass in the field and, thus, with root length (Van Beem et al. 1998). Furthermore, root pulling force (studies a and d2) was included since it relates to root density and,

Table 1 Summary table of QTL studies reporting traits related to root length. Experiment ID of the QTL study, number of treatments (Tr.), number of independent replications per treatment (Rp.) and the total number of biological replications,

i.e. plants per genotype and treatment (BRp) are given. Several years or locations within a field experiment are considered one treatment with as many independent replications as years or locations (see ID d2)

Cross Name ^a	Map dens. (cM)	ID	Cross Type ^b	Media and treatment ^c	Stage ^d	Tr. #	Rp. #	BRp. #	Traits ^e	QTLs per trait ^f	Pop. Size	Map. Method ^g	Reference
Poly17×F2	14.8	a	F2	Pot	R6	1	1	1	RPF, NO _{CrAx} , NO _{SeAx}	5.0	81	IM	Lebreton et al. 1995
<u>Io</u> ×F2 ^h	12.1	b	F5:6 RIL	Field	R1-2	1	2	30	NO _{Cr5Ax} , NO _{Cr6Ax} , NO _{Cr7Ax}	1.0	100	IM	Guingo et al. 1998
F271×F288	20.3	c	F7 RIL	Field	R6	1	1	5	NO _{Cr5Ax} , NO _{Cr6Ax} , NO _{Cr7Ax}	2.3	135	CIM	Barrière et al. 2001
Lo964× <u>Lo1016</u>	9.8	d1	F2:3	Hydroponics	V2	1	4	44	DW _{Se} , L _{PrAx}	10.5	171	CIM	Tuberosa et al. 2002a, b
		d2	F2:3	Field	R2	1	3	30	RPF	10.0	118	CIM	Landi et al. 2002
		d3	F2:4	Pot	V1	1	2	6	L _{PrAx} , L _{SeAx} , L _{PrLat} , L _{SeLat} , NO _{SeAx}	4.8	168	CIM	Hund et al. 2004
B73× <u>Mo17</u>	8.9	e1	RIL	Pot, phosphorus/mycorrhiza	6 wks	3	2	3	Vol _{Rt}	1.0	167	CIM	Kaeppler et al. 2000
		e2	F10 RIL	Paper, phosphorus	V1-2	2	3	3	L _{PrLat} , NO _{PrLat}	6.5	160	CIM	Zhu et al. 2005
		e3	F10 RIL	Paper, phosphorus	V1-2	2	3	3	L _{SeAx} , NO _{SeAx}	4.5	162	CIM	Zhu et al. 2006
<u>Z3</u> ×87-1	8.8	f	F8 RIL	Hydroponics/nitrogen	6-leaf tip	2	3	9	L _{Ax} , L _{Axi} , L _{Lat} , MaxL _{Ax} , NO _{Ax}	2.2	94	CIM	Liu et al. 2008
<u>CML444</u> × <u>SC-Malawi</u>	13.2	g1	F7 RIL	Paper	V1-2	1	6	6	k _{Lat} , ER _{Ax} , L _{PrAx} , NO _{Ax}	3.0	236	CIM	Trachsel et al. 2009
		g2	F7 RIL	Field, drought	R1-2	3	2	20	RCT	11.0	236	ICIM	Messmer 2006
<u>Ac7643</u> × <u>Ac7729</u> / <u>TZSRW</u>	17.1	h1	RIL	Paper, water pot.	V1-2	2	6	6	NO _{CrAx} , NO _{SeAx}	3.5	208	CIM	Ruta et al. 2010
		h2	RIL	Paper, water pot.	V1-2	2	6	6	ER _{Ax} , k _{Lat} , L _{Ax} , L _{Lat}	2.0	208	CIM	Ruta et al. 2009
Association Panel UHOH	11.0/1.5 ⁱ	i	IL	Paper, Temp.	V1-2	3	8	8	ER _{Ax} , NO _{SeAx}	3.75	74	ANOVA	Reimer 2010

^a Contributing parent is underlined

^b Recombinant inbred line (RIL), inbred line (IL)

^c Growth media under controlled conditions (greenhouse or growth chamber): hydroponics, solid media in pots (pot), paper-based media in rolls or pouches (paper). Treatments: nutrients, water potential or temperature levels

^d Vegetative stages (Vx) with x indicating the number of fully developed leaves, reproductive stages (R1, silking; R2, blister; R6, physiological maturity and silage stage)

^e RPF, root pulling force; RCT, root capacitance, for other abbreviations see Table 2

^f Average number of QTLs per trait

^g Mapping methods were interval mapping (IM), composite interval mapping (CIM), inclusive composite interval mapping (ICIM), analysis of variance (ANOVA)

^h Crossed to F252 as a tester

ⁱ Density of SSR/AFLP map

thus, root length (Sanguineti et al. 1998). In contrast, root diameter (study b, d1 and d3), weight of the primary root (study d1) and root angles (study b, c) were not included. Traits related to the response of root traits to environmental factors (study e2, f and i) were omitted from the analysis as well. If available, robust QTLs detected across field experiments were preferred over QTLs detected in only one environment (study d2 and g2). Root QTLs of four studies (a, b, d1 and d2) had been reviewed by Tuberosa et al. (2003).

In addition to these genome-wide mapping studies, the genomic regions of three root mutants were known as well as the positions of two other root QTLs. The position of these mutations were indicated on the IBM2 2008 Neighbors Frame reference map (Schaeffer et al. 2008) obtained from the Maize Genetics and Genomics Database (MaizeGDB; Lawrence et al. 2008). These were *rootless 1 (rtl)* in bin 3.04 at

208 cM (Jenkins 1930), *lateral rootless 1 (lrt1)* in bin 1.00-03 (Hochholdinger and Feix 1998) and the cloned mutation *rootless for crown and lateral roots (rtcs1)* in bin 1.01 at 103 cM (Taramino et al. 2007). Moreover, the QTL *seminal root 1 (sr1)*, bin 1.02, identified in the B73 × Gaspé Flint population (Giuliani et al. 2009), was included, as well as the QTL *Root-ABAI*, which had been identified in the Os420 × IABO78 population (bin 2.04, Tuberosa et al. 1998).

Terminology of root traits

To describe the different root traits (Table 2, Fig. 2), we adopted the common terminology for maize (Feix et al. 2000; Hochholdinger 2008). For the sake of comparability across species we also refer to the terminology proposed by the International Society of Root Research (ISRR) (Zobel 2009) and by the Plant Ontology Consortium (Ilic et al. 2007). The used abbreviations

Table 2 Proposed nomenclature and abbreviations. Root types can be referred to, either by means of a combination of abbreviated trait names, root types and branching orders or by counting the phytomers

Traits	Abbreviation		
Dry Weight	DW		
Elongation rate	ER		
Rate constant of the elongation	k		
Length	L		
Number	No		
Volume	Vol		

Root type (ZM ^a , PO ^b /ISRR ^c)	Abbreviation	Phytomer/ internode	Synonyms
Primary ^{ab} /tap ^c	Pr		
Embryonic roots ^{ab}			
Seminal ^{ab} /basal ^c	Se	0	scutellar nodal root ^b
Crown ^{ab}	Cr	>0	
Crown roots from whorl n to n_{max} ($n=1, \dots, n_{max}^d$)	Crn	n	
Prop root ^b	Pp	$>n_{max}$	brace root ^b ; aerial nodal root ^e
Prop roots from whorl p to p_{max} ($p=1, \dots, p_{max}^d$)	Ppn	$n_{max} + p$	

Branching order	Abbreviation	Order	Synonyms
Axile	Ax	0	main root
Lateral	Lat	$> = 1$	branch root
Laterals of order m ($m=1-m_{max}^d$)	Latm	m	

^a According to Feix et al. (2000) for *Zea mays* (ZM)

^b According to Plant Ontology Consortium (PO, on www.plantontology.org, accessed October 21, 2009)

^c According to International Society of Root Research (ISRR)

^d Maximal numbers depend on genotype and environment

^e Proposed by Hoppe et al. (1986)

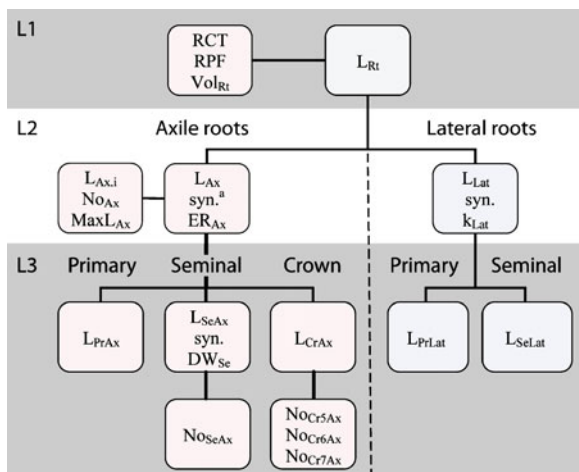

Fig. 2 Ontology of traits (QTLs) related to root length. Trait coding: [Trait]_[root type]_[branching order]. See Table 2 for abbreviation. ^a synonym

consist of the trait name followed by root type and branching order in subscript, e.g. L_{PrLat} for the length of the primary lateral roots. The term “nodal roots” includes those, which emerge sequentially at the top of each node, i.e. the seminal, crown and prop roots. More generally, nodal roots emerge from successive segmentation units (phytomers), with each phytomer consisting of a leaf, leaf node, internode, root primordial and axillary bud (Kisselbach 1999). Successive phytomers/nodes are numbered from 0 to n . The first node, i.e. the scutellar node from which the seminal roots emerge, is defined as node 0 (Hoppe et al. 1986; Pages et al. 1989). Accordingly, No_{Cr7Ax} refers to the number of axile roots on the seventh whorl of the crown roots. Note that this is the eighth whorl when the scutellar node is considered as the first node, as done by Guingo et al. (1998, study b) and Barrière et al. (2001, study c) according to the suggestion of Girardin et al. (1986).

Ontology of root traits

The ontology of root traits (Fig. 2) was defined so that all the observed traits were clustered hierarchically into root length (L_{Ri}) as the overall meta trait. Total root length was divided into the length of axile (L_{Ax}) and lateral (L_{Lat}) roots. The elongation rates of axile roots (ER_{Ax}) and the rate constant of lateral root elongation (k_{Lat}) were considered synonyms of L_{Ax} and L_{Lat} , respectively. Axile and lateral roots were

subdivided into primary, seminal and crown roots and the components that contribute to their length. We considered lateral and axile roots to be at the second-order level (Fig. 2, L2) since three studies (g1, h2 and i) distinguished these but did not differentiate between root types. Root capacitance (RCT), root pulling force (RPF) and root volume (Vol_{Ri}) were considered to be related to overall root length. The average and maximum length of axile roots (L_{Ax} and $MaxL_{Ax}$; study f) as well as the number of axile roots (No_{Ax} ; studies f and g1) were considered to be related to the length of the axile roots.

Preparation of QTL data

According to Goffinet and Gerber (2000), we considered QTLs of the same trait at the same location to be independent when they were detected in different populations and/or under different treatment conditions. Dependent QTLs, in contrast, were eliminated. It was the case in study h2, where two QTLs for the length of the axile roots in bins 2.02 and 3.05 were eliminated from the analysis whereas the corresponding QTLs for the elongation rate of the axile roots were retained. Elongation rates were considered a more reliable measure for root morphology than root length, since they are not affected by differences in germination (see Hund et al. 2009b). In the case of study i, several marker-trait associations of the same trait were mapped to the same genomic region. Therefore, a first meta-analysis (see below) was conducted using study i only. The positions and confidence interval of the resulting preliminary meta-QTLs (Pre-MQTL) were then used in the meta-analysis across all studies, as suggested by Löffler et al. (2009). The prefix “ Mn ” was added to the trait identification (QTL ID, see below) of the Pre-MQTL, where n indicates the number of individual QTLs combined by each Pre-MQTL. Two QTLs for the length of axile roots in bin 7.02 and two QTLs for the number of seminal axile roots in bin 1.08 were combined. Three studies (e2, e3 and f) did not report the positions of the QTL peaks. We thus calculated the positions of the peaks as in between the reported flanking markers.

The QTL IDs, which link each QTL unambiguously to the original publication, are given in the supplements as [*Experiment*]_{Trait}_{LOD score}_{Chromosome.position in cM ± Sign of the additivity}. For example the QTL ID “g1|No.Ax|2.6|1.219+” refers to

a QTL detected in experiment g1 for the number of axile roots. The QTL had an LOD score of 2.6 and was located on chromosome 1 at 219 cM in the original map. The “+” indicates that the trait-increasing allele was contributed by the parental line whose name is underlined in Table 1, i.e. CML444 in this example. In the text, individual QTLs are referred to by a shorter QTL ID omitting the LOD score and the sign of additivity.

Meta-analysis of QTLs

The software package MetaQTL 1.1.2 (Veyrieras et al. 2007) was used for the QTL meta-analysis. The software provides a complete statistical procedure to establish a genome-wide consensus model for both the marker and the QTL positions. First, the nine distinct genetic maps were merged into a single consensus map using a weighted least squares model. Second, the QTLs of these nine maps were projected onto this consensus map, and the putative number of QTL clusters (MQTLs) was determined using a Gaussian mixture model. The subprograms used to perform these two steps are described below.

- a) Construction of the consensus map. The consensus map of the nine genetic maps was constructed according to the procedure in the MetaQTL tutorial (Veyrieras et al. 2005). The subprogram InfoMap was used to detect inversions between markers. The subprogram ConsMap was used to construct a preliminary consensus map and to compare its marker order with that of the IBM2 2008 Neighbors Frame reference map (“Neighbors 2008”; Schaeffer et al. 2008). The Neighbors Frame map was chosen because it contains only statistically significant loci. In subsequent steps, singleton markers (present in only one of the nine maps), which were inverted between the consensus map and the Neighbors 2008 reference map, were removed. In some cases markers occurring in more than one map were also removed in order to obtain the same marker order in both maps.
- b) Clustering and projection of QTLs. The extraction of meta-QTLs (MQTLs) involved several subprograms: QTLs were projected onto the consensus map (QTLProj), clustered (QTLClust), extracted (QTLModel) and projected onto the reference map (QTLProj).

Only those QTLs were projected, for which there was a pair of flanking markers that met the following criteria: the interval distance was shortened by less than a factor 0.25 or the p-value of the homogeneity test of equal distances was greater than 0.05 (the default settings of MetaQTL). One QTL ($f|_{L.at}|_{10.90}$) could not be projected because it did not meet these criteria. The number of QTL clusters per chromosome was determined based on the Akaike information criterion (AIC). Where available, confidence intervals were used to compute variances (studies a, b, g1, g2, h1, h2). Otherwise, R^2 values were used to estimate confidence intervals and variances (QTLClust, cimode model 1). Finally, the determined number of MQTLs per chromosome was extracted using the subprogram QTLModel and was projected onto the Neighbors 2008 reference map using the subprogram QTLProj. The projected MQTLs were named according to the root ontology (Fig. 2) as those controlling mainly axile roots (Ax), lateral roots (Lat) and both branching orders (Rt). MQTLs were classified as being specific to axile or lateral root length when they harbored QTLs related to these root types and less than 50% of QTLs controlling overall root length (e.g. RPF and RCT).

Results

Characteristics of the QTL experiments

The size of the populations used for phenotyping ranged from 74 (pop. i) to 236 (pop. g) with an average of 154 (Table 1). The number of treatments per QTL experiment ranged from one to three. The treatments comprised nutrient stress (studies e1-3, and f), drought stress (studies g2, h1-2) or temperature stress (study i) (Table 1). Roots were grown on germination paper (six studies), in pots with solid substrate (three studies), in hydroponics (two studies) or under field conditions (four studies). The majority of eight studies evaluated root traits at the early seedling stage when about one to two leaves were fully developed (V1-V2 stage). Accordingly, the main focus of these studies was the embryonic root system. In the field, simple traits like root capacitance (study g2), root pulling force (study d2) or the number of the youngest belowground crown roots (study b and c) were measured at the reproductive stage.

Characteristics of the examined maps (results of subprogram InfoMap)

The average distance between markers ranged from 1.5 cM (pop. i) to 20.3 cM (pop. c) with an average of 12.2 cM (Table 1; map density). The number of detected QTLs per trait ranged from 1 (study b and e1) to 11 (study g2) with an average of 4.9. The different maps had 23.5 markers per chromosome in common (20% of all markers), with values ranging from 17 on chromosome 10 to 37 on chromosome 1. Only one marker (*phi233376*, mapping populations f and i) was removed from the consensus map because of inconsistent marker order.

Results of the trait ontology analysis

From the 15 QTL studies, a total of 161 QTLs, including two Pre-MQTLs from study i, were projected. Of these 161 QTLs, 29 were related to the total root length, 102 to the length of axile roots and 30 to the length of lateral roots. Taking into account the hierarchy among traits (Fig. 2), 29 QTLs controlled the total root length (level 1), 32 QTLs controlled the branching order (level 2) without distinguishing between root types and 100 QTLs controlled both branching order and root type (level 3). Of the latter, 16 QTLs were detected for the primary axile root, 44 for the seminal axile roots, 18 for the crown axile roots, 18 for the primary lateral roots and four for the seminal lateral roots.

Results of QTL clustering

The 161 QTLs were grouped into 24 MQTLs and 16 remaining individual QTLs (Fig. 3). The MQTLs combined QTLs of two (six cases), three (16 cases), four (one case) and five (one case) mapping populations. The number of clusters per chromosome ranged from seven on chromosome 1 to two on chromosome 9. The MQTLs were classified according to branching order (see Fig. 2) into QTLs controlling mainly the axile roots (Ax-1 to 20), QTLs controlling the lateral roots (Lat-1 to 3) or both root types (Rt-1 to 17). The MQTL Ax-2 was classified as being specific to axile roots because it harbored 10 QTLs controlling axile roots but only one QTL for lateral roots.

The accuracy of the estimated positions of the MQTLs was judged by evaluating their confidence

intervals. The six most accurate MQTLs with confidence intervals below an arbitrary threshold of 30 cM on the Neighbors 2008 reference map were Rt-6 and 8, Ax-2, 3, 4, and 12. The least accurate MQTLs with confidence intervals larger than 90 cM were recorded for six individual QTLs (Rt-14, 16, Ax-5, 10, 13, 17, 18, and Lat-2).

The following loci deserve special attention:

MQTL Rt-6 (bin 2.04) was located 15 cM after the *Root-ABAI* locus and harbored 10 QTLs from three mapping populations. It constitutively controlled the length and number of seminal roots across phosphorus treatments (study e2) and root capacitance across levels of water stress (study g2) as well as the numbers and elongation rates of axile roots (study g1) and root pulling force (study a).

MQTL Ax-2 (bin 1.07) mainly controlled the root number per whorl throughout developmental stages in five populations. This is concluded since most of the QTLs at this locus controlled the numbers and lengths of the roots (pop. e, g and i). Furthermore, the number of crown roots that emerged from internodes five to seven was controlled at this locus (study c).

MQTL Rt-7 (bin 3.06) controlled a range of different root traits during all stages of development in four populations. The locus included root pulling force detected in two independent populations (a, d), which indicates the importance of the locus for later stages of development. Rt-7 also controlled lateral rooting in two different populations (e and h) indicating its potential influence on the foraging of immobile nutrients.

MQTL Ax-15 (bin 7.03) controlled axile roots in three environments (pop. d) and in two other populations (g and i). Of particular interest is the fact that RPF was negatively collocated with seedling root traits (pop. d).

Collocations among QTLs for root types or branching orders

Among the eight loci controlling both the lengths of primary and seminal roots, four showed adverse effects between root types (Ax-1, Rt-3, Rt-10 and Rt-13). The other four simultaneously increased the length of both root types (Rt-3, Rt12, Ax-15 and Ax-16). Thus, both cases existed, loci affecting root

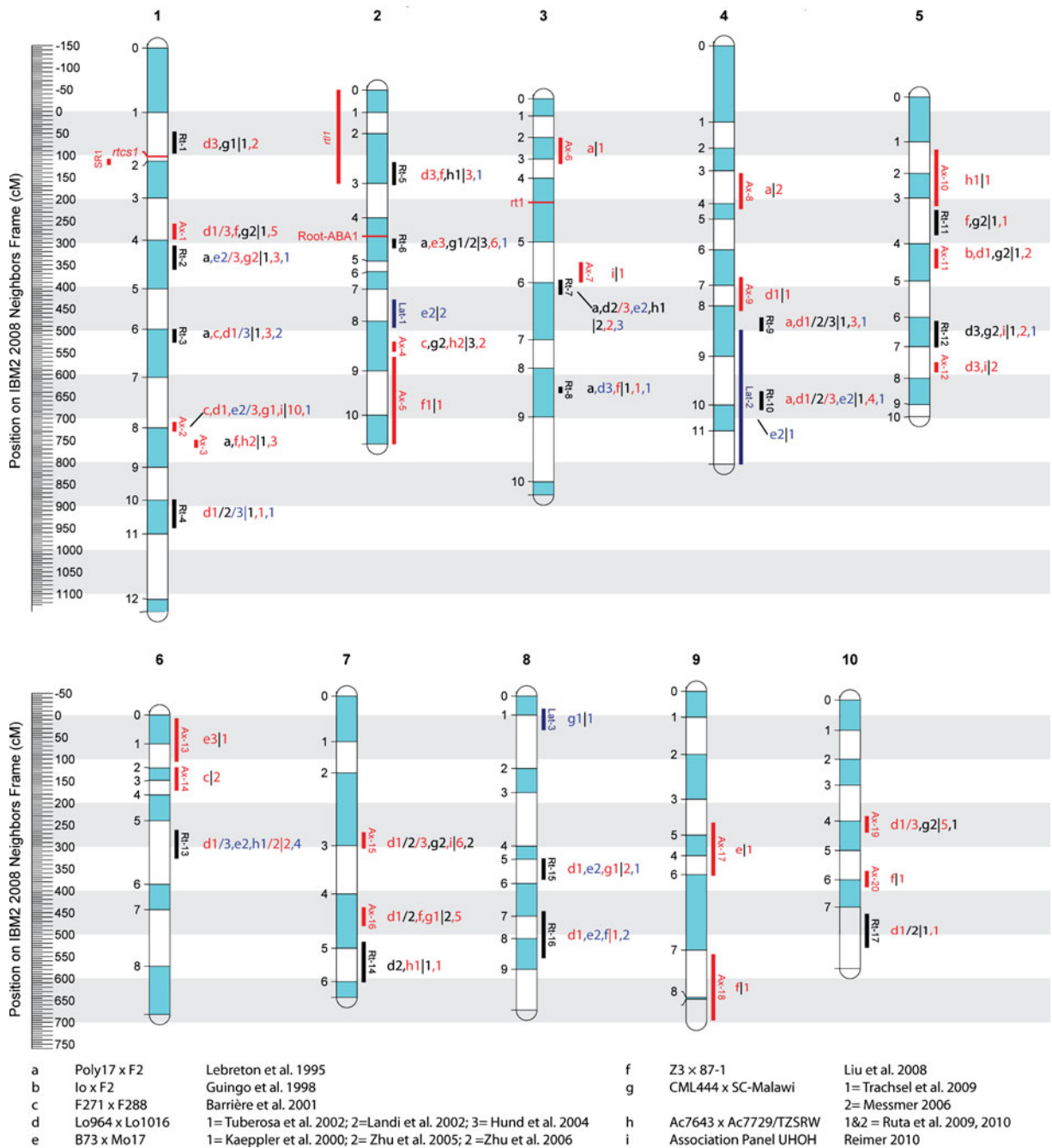

Fig. 3 Reference map of the meta-analysis. The scale indicates the position on the Neighbors 2008 reference map in cM. Labels on the left indicate the bin number of each chromosome (shaded areas) as well as mapped mutations and known genes controlling the root growth of maize. Vertical bars right to chromosome show confidence intervals of meta-QTLs. Combinations of letters followed by a number (left of the vertical bar

“|”) refer to different mapping experiments (Table 1). Numbers (right of the vertical bar) indicate the number of detected root QTLs per branching order (Rt, Ax, Lat). Colors indicate whether only axile roots (Ax: red) lateral roots (Lat: blue) or overall root length (Rt: black) was involved in the meta-QTL or study

system architecture (with opposed additive effects) and loci affecting overall root system size (with consistent additive effects). All these QTLs were detected in population d.

QTL for the number and length of axile roots were usually positively collocated (Ax-1, Ax-2, Rt-6, and Ax-16), with the exception of Ax-19. This is not surprising, because usually the cumulated length of all the individual axile roots was measured, which increases with increasing numbers of axile roots. Furthermore, the QTLs controlling axile roots and those controlling lateral roots were also usually positively collocated (Rt-1, Rt-7, Rt-9 and Rt-12), with the exception of Rt-13. This indicates that most of the loci controlled the size of the root system rather than causing drastic changes in the root architecture. Changes in root architecture would be indicated by negative collocations of the different branching orders. However, relative differences in additive effects of these QTLs may still alter root architecture even though the QTL collocation among branching orders is positive.

MQTLs detected at the seedling stage and in the field

Sixteen detected MQTLs controlled root growth across developmental stages, i.e. at the seedling stage under controlled conditions and later in the field. The number and dry weight of seminal roots were most frequently collocated with root traits measured in the field. Eight collocations of QTLs across developmental stages were detected within the same population (one in pop. g and seven in pop. d). Half of them showed positive associations between the seedling traits and the field traits (Rt-4 in bin 1.10; Rt-6 in bin 2.04; Rt-9 in bin 4.08 and Rt-10 in bin 4.09). We consider these loci as particularly interesting for future evaluations.

Discussion

Collocations of QTLs across developmental stages

Several studies mentioned here focused on QTLs controlling root length at the seedling stage, mainly because of the higher throughput that can be realized at this stage. It is generally assumed that these early characteristics have some predictive value for later stages of development and even for grain yield, as discussed by Tuberosa et al. (2002a). The authors

suggested to use the sign of the association (positive or negative) between the QTLs of two traits to judge if linkage or pleiotropy is more likely. Accordingly, pleiotropy is indicated when the sign of the association within each population remains the same at the majority of these loci. We did not find strong evidence for pleiotropy based on this assumption of “consistent signs”. The eight collocations among root traits of young and adult plants within the same population had no consistent signs. This result is in line with the lack of correlation among root traits measured in different environments and developmental stages in other crops. For example, root traits of wheat (Wojciechowski et al. 2009) and barley (Hargreaves et al. 2009), assessed at the early seedling stage in gel chambers, were not correlated with root traits at later stages of development or in soil substrate. However, the assumption of consistent signs to test for pleiotropy may not be reasonable for our type of studies. The reason for this is that the signs of the association may depend on the gene products, the environment and the developmental stage. For example, a locus with a negative effect on one root type may have a positive effect on another root type by reducing competition for carbohydrates. By contrast, a locus enhancing carbohydrate supply may positively affect all root types. Thus, the detected association may still be caused by pleiotropy even so they lack consistent signs. Can we, however, expect pleiotropic effects for root length across all stages of development? At least three factors explain why this may not hold true. Genotypes may differ in i) germination speed, ii) the mobilization of seed reserves and iii) the genetic control of their embryonic roots compared to their crown roots. These factors affect early root morphology but do not affect root morphology at later stages of development, as discussed in the next section. Even the maternal environment can affect gene expression as shown for germination of *Arabidopsis thaliana* (Donohue 2009). It may likely affect early root elongation, too. Unfortunately, there is little research conducted to clarify the influence of the maternal genetic environment on early plant growth.

Effect of germination, seed size and seed quality on root QTLs

Differences in germination and early nutrient supply by the seed can considerably affect the ranking of genotypes with respect to root length and root

morphology. For example, the length of the lateral roots of a genotype that germinated one day earlier than another genotype may be overestimated by more than 100% at the V1 stage (Hund et al. 2009b). This strong overestimation is due to the fact that the total length of the lateral roots increases exponentially during the early growth phase. Therefore, some QTLs for root length at the seedling stage might in fact be simply QTLs for germination speed. This might have been the case in two QTLs detected in the Lo964 × Lo1016 population (d, Rt-12 in bin 5.06 and Rt-13 in bin 6.05), controlling the length of the primary lateral roots, since they collocated positively with QTLs for a fast germination (Hund et al. 2004). These loci probably control seed vigor rather than root morphology.

Apart from differences in germination, the amount and mobilization of nutrient reserves from the seed may alter root morphology. This effect will diminish when seed reserves are exhausted. For example, removal of the endosperm reduced the length and density of lateral roots within 10 cm from the primary root of nine-days-old seedlings (Enns et al. 2006). Similarly seed size may affect root morphology. Trachsel et al. (2009) reported a weak positive correlation between hundred kernel weight and the elongation rate of axile roots and detected positive collocations at MQTL Rt-2 (bin 1.04), Rt-6 (bin 2.04) and Ax-16 (bin 7.04).

Finally, studies of root mutants and the QTL studies considered here provide evidence that the embryonic roots are, at least in part, under a different genetic control than the crown roots developing later. For example, the mutation *rtl* (bin 1.01-3) affects only shoot-born roots, mainly prop roots (Jenkins 1930). By contrast, the mutation *rtcs* (Hetz et al. 1996) affects the formation of both crown and seminal roots but not the primary root.

Thus, certainly not all QTLs detected at the seedling stage can be expected to control root growth across developmental stages. Nevertheless, there are examples for root QTLs that were expressed at the very early stage as well as later on. For example, a QTL controlling seedling root morphology (Rt-3, study d1) turned out to affect root morphology and other agronomic traits at later stages of development (Landi et al. 2009, 2010). Moreover, the embryonic root system may contribute more efficiently to water uptake and grain yield than the crown roots do, as discussed at the end of the next section.

Collocations between root QTLs and QTLs for yield components and other relevant traits related to yield

The ultimate aim of studying root system architecture of crops is to understand its influence on harvestable yield. Identifying key genomic regions by means of QTL collocations is an important approach to reach this aim. The collocations of QTLs for root characteristics and other morpho-physiological traits were discussed by Tuberosa et al (2003) and in some of the papers used for our meta-analysis here (h2, Ruta et al. 2009; h1, Ruta et al. 2010; g1, Trachsel et al. 2009; d1, Tuberosa et al. 2002b). Here we present the most relevant collocations identified by these authors and consider the sign of the additive effects to judge the consistency of the collocations (positive or negative collocation). To enhance readability we omit the phrase “QTLs for ...” when describing the collocations of QTLs for different traits.

At MQTL Rt-6 (bin 2.04), root vigor (Trachsel et al. 2009) and root capacitance were negatively collocated with leaf greenness under different water regimes in the field (Messmer 2006); root pulling force was positively collocated with leaf size (Lebreton et al. 1995). Near isogenic hybrids carrying the positive allele at the *Root-ABA1* locus had consistently larger and more horizontal root systems (Giuliani et al. 2005). They also had higher contents of leaf abscisic acid and showed less root lodging under all water regimes as well as a decreased yield under water stress (Landi et al. 2007).

At MQTL Rt-13 (bin 6.05), there was a negative collocation of the rate constant of lateral root elongation (Ruta et al. 2009) and a positive collocation of the number of seminal roots (Ruta et al. 2010) with the anthesis-silking interval (Ribaut et al. 1996). Thus, a higher number of axile roots seemed to be favorable for drought tolerance, while a stronger development of lateral roots seemed to be unfavorable.

At MQTL Ax-16 (bin 7.04), there was a positive collocation between the number and length of axile root (Trachsel et al. 2009) with grain yield and other yield components (Messmer et al. 2009).

At MQTL Ax-4 (bin 2.08), root capacitance was positively collocated with the anthesis-silking interval under water stress (Messmer et al. 2009). At the same locus, the number of seedling crown roots (Ruta et al. 2010) was also positively collocated with the anthesis-silking interval (Ribaut et al. 1996). Enhanced rooting at the seedling stage would therefore

have a negative effect on drought tolerance, as indicated by the larger anthesis-silking interval.

At **MQTLs Rt-3, Ax-2 and Ax-19**, the dry weight of the seminal roots was consistently positively collocated with grain yield and the drought tolerance index of grain yield in the field (Tuberosa et al. 2002b). These three loci affected root architecture, too: the diameter, the length or the dry weight of the primary root was negatively collocated with the dry weight of the seminal roots (Tuberosa et al. 2002b). This negative association among root types may partly explain the strongly altered root system architectures of the parents of this population (Lo964 and Lo1016; Fig. 1). The effect of Rt-3 (bin 1.06) has been validated by Landi et al. (2009, 2010) and is discussed below.

The above-mentioned collocations indicate that an increased root growth does not always lead to higher yield or to better drought tolerance (e.g. Rt-6, Ax-4). This is supported by the finding that RILs of the B73 x Mo17 population with poorer early lateral and adventitious (crown) root development yielded better under drought than those with more vigorous early root development (Bruce et al. 2002). Assuming pleiotropic effects, the negative collocations may be explained by higher carbon costs and increased stress signaling associated with larger root system or other factors, such as the timing of water use. Concerning the first explanation, larger root systems may have costs for growth and respiration exceeding the benefits of a better access to water and nutrients (Nielsen et al. 1994). Furthermore, transpiration may be decreased due to an increased abscisic acid signal from roots in dry superficial soil layers as discussed by Giuliani et al. (2005) and Hund et al. (2009a). Concerning the second explanation, larger and deeper root systems early in development may exhaust stored soil water too early leading to drought stress during grain filling as discussed by Passioura (1972). Thus, the answer to the question whether a larger root system may be beneficial is dependent on the target environment. Nevertheless, some root traits were identified as beneficial in a large number of studies.

The number of seminal roots was consistently associated with grain yield and secondary traits for grain yield (e.g. Rt-3, Rt-13, Ax-2, Ax-19 and possibly Ax-16). This association may be even in agreement with reduced carbon cost or a better timing of water use. Seminal roots frequently have shorter

lateral roots compared to the primary roots (Hund et al. 2004, 2007, 2009b), which may reduce their carbon costs. Furthermore, all the water that is taken up by seminal roots has to pass the mesocotyl. As a result, an increased number of seminal roots may grant access to a larger soil volume without increasing the transport capacity of water to the shoot. Less water uptake may save water for later stages of development as shown for wheat (Richards and Passioura 1989). We claim that seminal roots were even indirectly selected by breeders: Sanguineti et al. (2006) reported that breeders selected for a reduced weight of shoot and embryonic roots. This may be a result of an adaptation to an increased planting density in the examined material during the last 70 years (Duvick 2005). Important for the discussion here is, that the weight of the seminal root remained constant during selection (Sanguineti et al. 2006), which we interpret as sign of indirect selection. Looking at the mature root system in Fig. 1b one may doubt that seminal roots contribute significantly to water and nutrient uptake. Nevertheless, the embryonic root system was significantly more efficient at supplying water to the shoot on the basis of volume/dry weight or surface area than the crown roots (Navara et al. 1994). A reason for this may be that seminal roots of maize are among the root types with greatest length around silking (Araki et al. 2000) and, thus, the potential to root deepest. Seminal roots have only the “potential” to root deepest, since their rooting depth depends on their growth angle. Root types emerging from early internodes, like the seminal roots, orient more horizontally than those emerging from later internodes (Araki et al. 2000). However, genetic variation for root angles of seminal roots exists (Hund 2010; Singh et al. 2010) and ranges from almost vertical to almost horizontal (Hund 2010). Moreover, according to Navara et al. (1994), the embryonic root system (termed seminal roots by Navara et al.) supplied a significant amount of water to the growing ear. In field-grown wheat (*Triticum aestivum*), barley (*Hordeum vulgare*) and triticale (*Triticale hexaploide*) the deepest roots were primary axile roots (these species possess two to six primary axile roots) and lateral roots while no nodal roots were detected (Watt et al. 2008). Given these evidences, the loci controlling the number and growth of seminal roots together with yield components may be promising to adapt genotypes to conditions where water is scarce during

later stages of development. However, as pointed out by de Dorlodot et al. (2007), “high genetic resolution is required to ascertain accurately the role of linkage in the cosegregation of QTL effects for traits that are plausibly related on a functional basis”.

QTLs targets for gene cloning

Some root QTLs are being considered for verification and gene cloning. For a QTL controlling the length of the primary axile root and the dry weight of the seminal roots (Study d1, Tuberosa et al. 2002a, b) assigned to MQTL Rt-3, near-isogenic lines were developed (Landi et al. 2009, 2010). The QTL showed consistent effect on overall plant vigor including roots, shoots and agronomic traits across levels of irrigation, genetic backgrounds and levels of inbreeding. This locus may have an effect on lateral root morphology because the length and diameter of the seminal lateral roots were negatively collocated (Hund et al. 2004). A second locus, targeted for verification and positional cloning, is *seminal root 1* (*sr1*) in bin 1.02 (Giuliani et al. 2009). It is located 43 cM after Rt-1 and about 12 cM after the cloned mutation *rtcs* (Taramino et al. 2007) and does not seem to be controlled by the same gene as *rtcs* (Giuliani et al. 2009). A third locus targeted for positional cloning is *Root-ABA1* in bin 2.04 (Giuliani et al. 2005; Landi et al. 2007). This locus is 17 cM away from MQTL Rt-6, one of the key loci identified herein. As discussed by Giuliani et al. (2005) and Landi et al. (2007), *Root-ABA1* has pleiotropic effects on other traits at various stages of development including root lodging and grain yield. The same applies for the QTLs clustering at Rt-6 in population g. We identified further loci that are interesting targets for verification and cloning, such as Ax-2 or Ax-15.

Limitations of the analysis

MetaQTL helped to collocate QTLs across genomes. Its clustering procedure provided an objective criterion to define MQTLs. However, certainly not all these MQTLs are likely caused by an underlying pleiotropic gene action. Some of these MQTLs may assemble several closely linked QTLs. This is evidenced by at least two loci, where two separate QTLs were detected for the same traits within the same experiment. This was the case for two QTLs at Ax-19 (d1|

DW.Se|10.60 and d1|DW.Se|10.74, Supplement 1) and two QTLs at Ax-16 (d2|RPF|7.74 and d2|RPF|7.90, Supplement 1).

We restricted the meta-analysis to traits related to root length, for the sake of clarity. The list of other traits that could be considered in addition is long. It contains QTLs mapped for other architectural and anatomical traits such as root angle (Barrière et al. 2001; Guingo et al. 1998; Omori and Mano 2007), diameter (Guingo et al. 1998; Hund et al. 2004; Tuberosa et al. 2002b), and branching pattern (Zhu et al. 2005) or the formation of aerenchyma (Mano et al. 2007) but also adaptive traits such as response to abiotic (Reimer 2010; Ruta et al. 2009, 2010) or biotic stress. Furthermore, most studies evaluated recombinant inbred lines which do not allow estimating dominant effects. Dominance effects for root growth exist (Hoecker et al. 2006) and may be important in hybrid breeding. However, most of these traits and the effect of dominance were evaluated in only few studies, making a more general comparison difficult. Research efforts should be intensified to identify root traits with a high heritability across developmental stages but also in developing phenotyping platforms or methodologies to map root QTLs at later stages of development (Trachsel et al. 2010), which could be more predictive for root growth under realistic field conditions.

Conclusion

Among the 16 detected MQTLs, some had a relatively precise position on the reference map and harbored a large number of QTLs from at least three populations. The collocation of these QTLs and their signs of the additive effects suggest a complex genetic architecture of root traits within and across developmental stages. We detected fewer genes controlling root growth across developmental stages as one may expect. For such genes changes in root architecture would be simple to predict. However, we detected more genes with a positive pleiotropic effect on early root growth, water uptake and yield as we expected. In particular, the number of seminal roots was consistently associated with grain yield and secondary traits related to grain yield (e.g. Rt-3, Rt-13, Ax-2, Ax-19 and possibly Ax-16). We did not expect such collocations given the insignificant appearance of the

embryonic root system compared to the root system of a mature maize plant. An explanation of the collocations may be that the seminal roots are the earliest root type with a great potential to tap deep water sources.

We consider several loci of interest for QTL validation or cloning. They were detected in three or more populations in different environments or at different developmental stages and were collocated with QTLs related to grain yield (Rt-6, Rt-13, Ax-4, Ax-2 and Ax-16). The loci Ax-2 and Rt-7 are particularly interesting, because they involved the greatest number of populations (five and four, respectively). From an experimental point of view, it would be interesting to select for loci, which cause a drastic change in the architecture of the root system: for example, loci with a negative collocation between the length of the primary and the seminal roots (Ax-1, Rt-3, Rt-10 and Rt-13). There are a large number of root traits that can be altered to enhance the efficiency of the root system. Near-isogenic lines with different root architecture, would enable us to decipher the eco-physiological role, if any, of this morphological diversity.

Acknowledgements We would like to thank Prof. Dr. Peter Stamp for supporting this project and Marcia Schoenberg for linguistic corrections.

References

- Araki H, Hirayama M, Hirasawa H, Iijima M (2000) Which roots penetrate the deepest in rice and maize root systems? *Plant Prod Sci* 3:281–288
- Barrière Y, Gibelin C, Argillier O, Mechin V (2001) Genetic analysis in recombinant inbred lines of early dent forage maize. I—QTL mapping for yield, earliness, starch and crude protein contents from *per se* value and top cross experiments. *Maydica* 46:253–266
- Bruce WB, Edmeades GO, Baker TC (2002) Molecular and physiological approaches to maize improvement for drought tolerance. *J Exp Bot* 53:13–25
- Courtois B, Ahmadi N, Khowaja F, Price A, Rami J-F, Frouin J, Hamelin C, Ruiz M (2009) Rice root genetic architecture: meta-analysis from a drought QTL database. *Rice* 2:115–128
- Donohue K (2009) Completing the cycle: maternal effects as the missing link in plant life histories. *Philos. Trans. R. Soc. B-Biol. Sci.* 364:1059–1074
- de Dorlodot S, Forster B, Pages L, Price A, Tuberosa R, Draye X (2007) Root system architecture: opportunities and constraints for genetic improvement of crops. *Trends Plant Sci* 12:474–481
- Duvick DN (2005) The contribution of breeding to yield advances in maize (*Zea mays* L.). In *Adv Agron.* Academic Press, pp 83–145
- Enns LC, McCully ME, Canny MJ (2006) Branch roots of young maize seedlings, their production, growth, and phloem supply from the primary root. *Funct Plant Biol* 33:391–399
- Feix G, Hochholdinger F, Park WJ (2000) Maize root system and genetic analysis of its formation. In: Waisel Y, Eshel A, Kafkafi U (eds) *Plant roots: the hidden half.* Marcel Dekker, New York, pp 205–220
- Feldman L (1994) The maize root. In: Freeling M, Walbot V (eds) *The maize handbook.* Springer-Verlag, New York, pp 29–37
- Fracheboud Y, Ribaut J-M, Vargas M, Messmer R, Stamp P (2002) Identification of quantitative trait loci for cold-tolerance of photosynthesis in maize (*Zea mays* L.). *J Exp Bot* 53:1967–1977
- Gardiner JM, Coe EH, Meliahancock S, Hoisington DA, Chao S (1993) Development of a core RFLP map in maize using an immortalized-F2 population. *Genetics* 134:917–930
- Girardin P, Jordan MO, Picard D, Trendel R (1986) Harmonization of terms used for the morphological description of maize. *Agronomie* 6:873–875
- Giuliani S, Sanguineti MC, Tuberosa R, Bellotti M, Salvi S, Landi P (2005) *Root-ABAI*, a major constitutive QTL, affects maize root architecture and leaf ABA concentration at different water regimes. *J Exp Bot* 56:3061–3070
- Giuliani S, Busatto C, Salvi S, Ricciolini C, Carraro N, Presterl T, Ouzunova M, Conti S, Sanguineti MC and Tuberosa R (2009) Genetic dissection of root characteristics at the seminal and seedling level in maize. In XXI International Conference of the EUCARPIA Maize and Sorghum Section, June 21–24, Bergamo, Italy
- Goffinet B, Gerber S (2000) Quantitative trait loci: a meta-analysis. *Genetics* 155:463–473
- Gregory PJ, Bengough AG, Grinev D, Schmidt S, Thomas WTB, Wojciechowski T, Young IM (2009) Root phenomics of crops: opportunities and challenges. *Funct Plant Biol* 36:922–929
- Guingo A, Hébert Y, Charcosset A (1998) Genetic analysis of root traits in maize. *Agronomie* 18:225–235
- Hargreaves CE, Gregory PJ, Bengough AG (2009) Measuring root traits in barley (*Hordeum vulgare* ssp *vulgare* and ssp *spontaneum*) seedlings using gel chambers, soil sacs and X-ray microtomography. *Plant Soil* 316:285–297
- Hetz W, Hochholdinger F, Schwall M, Feix G (1996) Isolation and characterisation of *rtcs*, a mutant deficient in the formation of nodal roots. *Plant J* 10:845–857
- Hochholdinger F (2008) The maize root system: morphology, anatomy, and genetics. In: Hake SC, Bennetzen JL (eds) *Handbook of maize: its biology.* Springer, The Netherlands, pp 145–160
- Hochholdinger F, Feix G (1998) Early post-embryonic root formation is specifically affected in the maize mutant *lrtl*. *Plant J* 16:247–255
- Hochholdinger F, Tuberosa R (2009) Genetic and genomic dissection of maize root development and architecture. *Curr Opin Plant Biol* 12:172–177
- Hoecker N, Keller B, Piepho HP, Hochholdinger F (2006) Manifestation of heterosis during early maize (*Zea mays* L.) root development. *Theor Appl Genet* 112:421–429

- Hoppe DC, McCully ME, Wenzel CL (1986) The nodal roots of *Zea*—their development in relation to structural features of the stem. *Can J Bot-Revue Canadienne De Botanique* 64:2524–2537
- Hoshikawa K (1969) Underground organs of seedlings and systematics of Gramineae *Botanical Gazette* 130:192–203
- Hund A (2010) Genetic variation in the gravitropic response of maize roots to low temperatures. *Plant Root* 4:22
- Hund A, Frachboud Y, Soldati A, Frascaroli E, Salvi S, Stamp P (2004) QTL controlling root and shoot traits of maize seedlings under cold stress. *Theor Appl Genet* 109:618–629
- Hund A, Richner W, Soldati A, Fracheboud Y, Stamp P (2007) Root morphology and photosynthetic performance of maize inbred lines at low temperature. *Eur J Agron* 27:52–61
- Hund A, Ruta N, Liedgens M (2009a) Rooting depth and water use efficiency of tropical maize inbred lines, differing in drought tolerance. *Plant Soil* 318:311–325
- Hund A, Trachsel S, Stamp P (2009b) Growth of axile and lateral roots of maize: I development of a phenotyping platform. *Plant Soil* 325:335–349
- Ilic K, Kellogg EA, Jaiswal P, Zapata F, Stevens PF, Vincent LP, Avraham S, Reiser L, Pujar A, Sachs MM, Whitman NT, McCouch SR, Schaeffer ML, Ware DH, Stein LD, Rhee SY (2007) The plant structure ontology, a unified vocabulary of anatomy and morphology of a flowering plant. *Plant Physiol* 143:587–599
- Jenkins MT (1930) Heritable characters of maize XXXIV—rootless. *J Hered* 21:79–80
- Kaeppeler SM, Parke JL, Mueller SM, Senior L, Stuber C, Tracy WF (2000) Variation among maize inbred lines and detection of quantitative trait loci for growth at low phosphorus and responsiveness to arbuscular mycorrhizal fungi. *Crop Science* 40:358–364
- Kisselbach TA (1999) The structure and reproduction of corn, 50th anniversary ed. Cold Spring Harbor Laboratory Press, New York, USA
- Landi P, Sanguineti MC, Darrah LL, Giuliani MM, Salvi S, Conti S, Tuberosa R (2002) Detection of QTLs for vertical root pulling resistance in maize and overlap with QTLs for root traits in hydroponics and for grain yield under different water regimes. *Maydica* 47:233–243
- Landi P, Sanguineti MC, Liu C, Li Y, Wang TY, Giuliani S, Bellotti M, Salvi S, Tuberosa R (2007) *Root-ABAI* QTL affects root lodging, grain yield, and other agronomic traits in maize grown under well-watered and water-stressed conditions. *J Exp Bot* 58:319–326
- Landi P, Bellotti M, Ferri M, Giuliani S, Salvi S, Sanguineti MC, Tuberosa R (2009) Validation of a QTL on Bin 1.06 for root and agronomic traits in maize. In XXI International Conference of the EUCARPIA Maize and Sorghum Section, June 21–24, Bergamo, Italy
- Landi P, Giuliani S, Salvi S, Ferri M, Tuberosa R, Sanguineti MC (2010) Characterization of *root-yield-1.06*, a major constitutive QTL for root and agronomic traits in maize across water regimes. *J Exp Bot* doi:10.1093/jxb/erq192
- Lebreton C, Lazic Jancic V, Steed A, Pekic S, Quarrie SA (1995) Identification of QTL for drought responses in maize and their use in testing causal relationships between traits. *J Exp Bot* 46:853–865
- Liu JC, Li JS, Chen FJ, Zhang FS, Ren TH, Zhuang ZJ and Mi GH (2008) Mapping QTLs for root traits under different nitrate levels at the seedling stage in maize (*Zea mays* L.). *Plant and Soil* 305:253–265
- Löffler M, Schon CC, Miedaner T (2009) Revealing the genetic architecture of FHB resistance in hexaploid wheat (*Triticum aestivum* L.) by QTL meta-analysis. *Mol Breed* 23:473–488
- Lynch JP (2007) Roots of the second green revolution. *Aust J Bot* 55:493–512
- Ma XQ, Tang JH, Teng WT, Yan JB, Meng YJ, Li JS (2007) Epistatic interaction is an important genetic basis of grain yield and its components in maize. *Mol Breed* 20:41–51
- Mano Y, Omori F, Takamizo T, Kindiger B, Bird RM, Loaisiga CH, Takahashi H (2007) QTL mapping of root aerenchyma formation in seedlings of a maize x rare teosinte “*Zea nicaraguensis*” cross. *Plant Soil* 295:103–113
- Manschadi AM, Hammer GL, Christopher JT, deVoil P (2008) Genotypic variation in seedling root architectural traits and implications for drought adaptation in wheat (*Triticum aestivum* L.). *Plant Soil* 303:115–129
- Marandel G, Salava J, Abbott A, Candresse T, Decroocq V (2009) Quantitative trait loci meta-analysis of Plum pox virus resistance in apricot (*Prunus armeniaca* L.): new insights on the organization and the identification of genomic resistance factors. *Mol Plant Pathol* 10:347–360
- McCully ME (1999) Roots in soil: unearthing the complexities of roots and their rhizospheres. *Annu Rev Plant Physiol Plant Mol Biol* 50:695–718
- Messmer R (2006) The genetic dissection of key factors involved in the drought tolerance of tropical maize (*Zea mays* L.). Diss. ETH No. 16695., Zurich, Switzerland
- Messmer R, Fracheboud Y, Banziger M, Vargas M, Stamp P, Ribaut JM (2009) Drought stress and tropical maize: QTL-by-environment interactions and stability of QTLs across environments for yield components and secondary traits. *Theor Appl Genet* 119:913–930
- Nagel KA, Kastenholz B, Jahnke S, Van Dusschoten D, Aach T, Muhlich M, Truhn D, Scharf H, Terjung S, Walter A, Schurr U (2009) Temperature responses of roots: impact on growth, root system architecture and implications for phenotyping. *Funct Plant Biol* 36:947–959
- Navara J, Jesko T, Duchoslav S (1994) Participation of seminal roots in water-uptake by maize root-system. *Biologia* 49:91–95
- Nielsen KL, Lynch JK, Jabllokow AG, Curtis PS (1994) Carbon cost of root systems: an architectural approach. *Plant Soil* 165:161–169
- Omori F, Mano Y (2007) QTL mapping of root angle in F₂ populations from maize ‘B73’ x teosinte ‘*Zea luxurians*’. *Plant Root* 1:57–64
- O’Toole JC, Bland WL (1987) Genotypic variation in crop plant root systems. *Adv Agron* 41:91–145
- Pages L, Jordan MO, Picard D (1989) A simulation-model of the 3-dimensional architecture of the maize root-system. *Plant Soil* 119:147–154
- Passioura J (1972) Effect of root geometry on yield of wheat growing on stored water. *Aust J Agric Res* 23:745–752
- Reimer R (2010) Responses of maize (*Zea mays* L.) seedlings to low and high temperature: association mapping of root

- growth and photosynthesis-related traits. In AGRL. Diss. ETH No. 18807, Zurich
- Ribaut JM, Hoisington DA, Deutsch JA, Jiang C, Gonzalez de Leon D (1996) Identification of quantitative trait loci under drought conditions in tropical maize. 1. Flowering parameters and the anthesis-silking interval. *Theor Appl Genet* 92:905–914
- Richards RA, Passioura JB (1989) A breeding program to reduce the diameter of the major xylem vessel in the seminal roots of wheat and its effect on grain-yield in rain-fed environments. *Aust J Agric Res* 40:943–950
- Ruta N, Liedgens M, Fracheboud Y, Stamp P, Hund A (2009) QTLs for the elongation of axile and lateral roots of maize in response to low water potential. *Theor Appl Genet* 120:621–631
- Ruta N, Stamp P, Liedgens M, Fracheboud Y, Hund A (2010) Collocation of QTLs for seedling traits and yield components of tropical maize under limited water availability. *Crop Sci* 50:1385–1392
- Sanguineti MC, Duvick DN, Smith S, Landi P, Tuberosa R (2006) Effects of long-term selection on seedling traits and ABA accumulation in commercial maize hybrids. *Maydica* 51:329–338
- Sanguineti MC, Giuliani MM, Govi G, Tuberosa R and Landi P (1998) Root and shoot traits of maize inbred lines grown in the field and in hydroponic culture and their relationship with root lodging. *Maydica* 43:211–216
- Sass JE (1977) Morphology. In: Sprague CF (ed) Corn and corn improvement. American Society of Agronomy, Madison, pp 89–110
- Schaeffer ML, Sanchez-Villeda H, Coe E (2008) Neighbors 2008. In: Maize GDB <http://www.maizegdb.org/cgi-bin/displayrefrecord.cgi?id=1204261> (27. Oct 2009)
- Senior ML, Chin ECL, Lee M, Smith JSC, Stuber CW (1996) Simple sequence repeat markers developed from maize sequences found in the GENBANK database: map construction. *Crop Sci* 36:1676–1683
- Shen L, Courtois B, McNally KL, Robin S, Li Z (2001) Evaluation of near-isogenic lines of rice introgressed with QTLs for root depth through marker-aided selection. *Theor Appl Genet* 103:75–83
- Singh V, van Oosterom EJ, Jordan DR, Messina CD, Cooper M, Hammer GL (2010) Morphological and architectural development of root systems in sorghum and maize. *Plant Soil* 333:287–299
- Steele KA, Price AH, Shashidhar HE, Witcombe JR (2006) Marker-assisted selection to introgress rice QTLs controlling root traits into an Indian upland rice variety. *Theor Appl Genet* 112:208–221
- Taramino G, Sauer M, Stauffer JL, Multani D, Niu XM, Sakai H, Hochholdinger F (2007) The maize (*Zea mays* L.) *RTCS* gene encodes a LOB domain protein that is a key regulator of embryonic seminal and post-embryonic shootborne root initiation. *Plant J* 50:649–659
- Trachsel S, Messmer R, Stamp P, Hund A (2009) Mapping of QTLs for lateral and axile root growth of tropical maize. *Theor Appl Genet* 119:1413–1424
- Trachsel S, Kaepler SM, Brown KM, Lynch J (2010) Shovelomics: High throughput phenotyping of maize (*Zea mays* L.) root architecture in the field. Submitted to Plant and Soil. Plant Soil in press
- Tuberosa R, Sanguineti MC, Landi P, Salvi S, Casarini E, Conti S (1998) RFLP mapping of quantitative trait loci controlling abscisic acid concentration in leaves of drought-stressed maize (*Zea mays* L.). *Theor Appl Genet* 97:744–755
- Tuberosa R, Salvi S, Sanguineti MC, Landi P, Maccaferri M, Conti S (2002a) Mapping QTLs regulating morpho-physiological traits and yield: case studies, shortcomings and perspectives in drought-stressed maize. *Ann Bot* 89:941–963
- Tuberosa R, Sanguineti MC, Landi P, Giuliani MM, Salvi S, Conti S (2002b) Identification of QTLs for root characteristics in maize grown in hydroponics and analysis of their overlap with QTLs for grain yield in the field at two water regimes. *Plant Mol Biol* 48:697–712
- Tuberosa R, Salvi S, Sanguineti MC, Maccaferri M, Giuliani S, Maccaferri M, Sanguineti MC, Landi P, Tuberosa R, Giuliani S, Salvi S (2003) Searching for quantitative trait loci controlling root traits in maize: a critical appraisal. *Plant Soil* 255:35–54
- Van Beem J, Smith ME, Zobel RW (1998) Estimating root mass in maize using a portable capacitance meter. *Agron J* 90:566–570
- Veyrieras JB, Goffinet B, Charcosset A (2005) MetaQTL. In Version 1.0, France
- Veyrieras JB, Goffinet B, Charcosset A (2007) MetaQTL: a package of new computational methods for the meta-analysis of QTL mapping experiments. *BMC Bioinformatics* 8
- Watt M, Magee LJ, McCully ME (2008) Types, structure and potential for axial water flow in the deepest roots of field-grown cereals. *New Phytol* 178:135–146
- Wojciechowski T, Gooding MJ, Ramsay L, Gregory PJ (2009) The effects of dwarfing genes on seedling root growth of wheat. *J Exp Bot* 60:2565–2573
- Yazdanbakhsh N, Fisahn J (2009) High throughput phenotyping of root growth dynamics, lateral root formation, root architecture and root hair development enabled by PlaRoM. *Funct Plant Biol* 36:938–946
- Zhu JM, Kaepler SM, Lynch JP (2005) Mapping of QTLs for lateral root branching and length in maize (*Zea mays* L.) under differential phosphorus supply. *Theor Appl Genet* 111:688–695
- Zhu JM, Mickelson SM, Kaepler SM and Lynch JP (2006) Detection of quantitative trait loci for seminal root traits in maize (*Zea mays* L.) seedlings grown under differential phosphorus levels. *Theoretical and Applied Genetics* 113:1–10
- Zobel RW (2009) Report of the Root Nomenclature Workgroup ISRR V (1996) a Reprise. In Proceedings of the Seventh Symposium of the International Society for Root Research, September 4, 2009, Vienna. <http://rootrap.boku.ac.at/index.php?id=28>.
- Zobel RW, Weisel Y (2010) A plant root system architectural taxonomy: a framework for root nomenclature. *Plant Biosyst*, in press