

Thomas Jaecklin
Denis R. Morel
Peter C. Rimensberger

Volume-targeted modes of modern neonatal ventilators: how stable is the delivered tidal volume?

Received: 7 June 2005
Accepted: 13 October 2006
Published online: 22 November 2006
© Springer-Verlag 2006

Electronic supplementary material
Supplementary material is available in the online version of this article at <http://dx.doi.org/10.1007/s00134-006-0450-9> and is accessible for authorized users.

P. C. Rimensberger (✉)
Hôpital des Enfants,
6 rue Willy-Donzé, 1211 Geneva 14,
Switzerland
e-mail: peter.rimensberger@hcuge.ch
Tel.: +41-22-3824595
Fax: +41-22-3824675

T. Jaecklin · P. C. Rimensberger
Geneva University Hospital, Pediatric
Intensive Care Unit,
1211 Geneva 14, Switzerland

D. R. Morel
Geneva University Hospital,
Anesthesiology Investigation Unit,
1211 Geneva 14, Switzerland

Abstract Objective: Volume-targeted modes are designed to deliver a constant tidal volume (V_t) at lowest possible pressure independently of changes in compliance, resistance, and leak of the respiratory system. We examined whether these volume-targeted modes respond rapidly enough to sudden changes in respiratory mechanics (e.g., selective intubation, surfactant administration, endotracheal tube kinking, de-kinking, obstruction), resulting in insufficient or excessive V_t delivery. **Design and setting:** Bench study of six neonatal ventilators in the volume-targeted mode simulating preterm and full-term infant settings on a test lung. **Measurements and results:** Breath-to-breath expiratory V_t were measured after rapid compliance, resistance, and leak changes. Under our test settings all ventilators showed important volume overshooting following rapid increase in compliance or decrease in resistance. Between

one and 16 inflations were required to return to the set V_t . Some ventilators delivered inaccurate V_t under steady state condition while others showed considerable breath-to-breath V_t variability. **Conclusions:** We observed inaccurate V_t delivery under specific conditions as well as immediate and sometimes prolonged volume overshooting after a rapid respiratory system compliance increase or resistance decrease in volume-targeted modes of modern neonatal ventilators. Similar discrepancies between the set V_t and the delivered inflations can be harmful in clinical situations, especially in newborns. Their clinical relevance needs to be clarified with safety studies in the neonatal population and we encourage manufacturers to further improve the ventilators algorithms.

Keywords Mechanical ventilation · Neonate · Full-term · Preterm · Volume-targeted ventilation

Introduction

Chronic lung disease, or bronchopulmonary dysplasia, is in part thought to be a result of injurious ventilation (i. e., ventilator-induced lung injury, VILI) [1]. Limitation of tidal volumes (V_t , i. e., low V_t ventilation) has proved to be an effective tool to attenuate VILI [2, 3] and to improve outcome in the clinical setting [3]. For neonates pressure-limited ventilation has been the traditional mode of ventilation for over three decades for two major reasons: (a) pressure limitation has allowed minimizing

the risk of gross air leak (i. e., pneumothorax) and (b) technical limitations were given for reliable measurements of very small V_t . With the advent of small V_t ventilation as a lung-protective strategy and technological progress in the design of ventilators and pneumotachographs, volume-targeted modes [4] have been incorporated in many neonatal ventilators. These modes adapt peak inspiratory pressure (PIP) or inspiratory flow to the compliance and resistance of the patient's respiratory system in order to deliver the set V_t at the lowest possible airway pressure. The governing algorithm varies from one ventilator to the

other. Some use the measured V_t (expiratory or inspiratory, depending on the algorithm) of the previous, others of the current inflation to feedback the measured PIP. This feedback may affect the adequacy of V_t delivery upon rapid changes in compliance (e.g., exogenous surfactant administration, right main stem bronchus intubation, acute constitution or drainage of pneumothorax, and reopening of atelectasis), resistance (e.g., kinking and de-kinking of the endotracheal tube or its obstruction by secretion or meconium), and airway leak (e.g., variable endotracheal tube leak depending on infant's head position).

Many potential advantages of volume-targeted over pressure-controlled ventilation in neonates have been reported in the literature [5, 6, 7, 8, 9, 10, 11, 12, 13, 14]: Breath-to-breath variability of V_t has shown to be reduced [6, 7, 9, 10] and PIP and mean airway pressure to be lowered [5, 8, 13, 14]. Slower respiratory rates have been observed, but the underlying mechanism of this remains unclear so far [8, 10]. Decreased lung inflammatory response and cytokine production has been found [7, 14], probably due to decreased shear stress to the lung tissue, acceleration of weaning from mechanical ventilation has been reported [11, 12], and a lower incidence of intraventricular hemorrhage or intraparenchymal brain echodensities has been observed than with intermittent mandatory ventilation (synchronized or not) in pressure-controlled mode [11, 12], potentially due to the lower airway pressure and decreased repercussions on cerebral blood flow by the more stable V_t .

On the other hand, Abubakar et al. [6] have noted substantial V_t fluctuations around the set value in clinical settings, which was attributed to the breath-to-breath variability of the infants' respiratory effort and the incapacity of this ventilator mode to adjust its support instantaneously. Others have warned of the latency of V_t adaptation and the risk of volume overshooting [9, 15] and recommended close attention to the infant under volume-targeted ventilation [16]. To our knowledge, only one small, unpublished study has yet tested the algorithms of two ventilators on a bench and observed volume overshooting after rapid compliance increase with one ventilator [17]. The aim of

this bench study of six modern neonatal ventilators was to assess the adequacy of V_t delivery of their volume-targeted modes when acute resistance, compliance, or leak changes occur, in respect to potential safety issues.

Methods

Test circuit

The test circuit was mounted as shown in Fig. 1. The various ventilators equipped with a commercially available standard neonatal respiratory circuit (single-use neonatal respiratory circuit, Fisher & Paykel, Auckland, New Zealand) that allowed rapid leak changes, rapid resistance changes via a Manual Valve Switch (Hans Rudolph, Kansas City, USA) using different airway resistors (Michigan Instruments, Grand Rapids, USA) and rapid compliance changes on the Michigan Infant Training and Test Lung (Model 1601, Michigan Instruments, Grand Rapids, USA). This device simulates an infant respiratory system: the "lung" uses an elastomer bellow and expands as shown in Fig. 1 when gas is inflated via a simulated airway. The compliance can be adjusted from 1 to 15 ml/cmH₂O via a lateral spring opposing variable forces against the bellow expansion. The total "lung" capacity is 200 ml and the residual capacity is 70 ml. Expiratory V_t was measured with a Florian Neonatal Respiration Monitor (Acutronic, Hirzel, Switzerland) that has been validated for measurements of very small V_t [18]. The measured data were digitized with a Biopack MP 100 analogue/digital converter (Biopack Systems, Goleta, USA) with 200 samples per second and recorded on a personal computer. The Florian's sensor was located at the Y-piece right before the test lung but after the resistor and leak device and was calibrated according to the user manual before each test series with a new ventilator. The accuracy of its volume measurements was confirmed by the calibrated syringe method prior to our experiences, showing a maximum offset of only 3%.

Fig. 1 Test circuit with the ventilator connected to a variable resistor, a variable leak, and a test lung that allowed compliance variations. Respiratory measurements were performed via a Florian Neonatal Respiration Monitor and recorded on a personal computer (PC). P/V-Sensor Pressure/flow sensor. Note: The Servo-i's P/V-Sensor is not located at the Y-piece

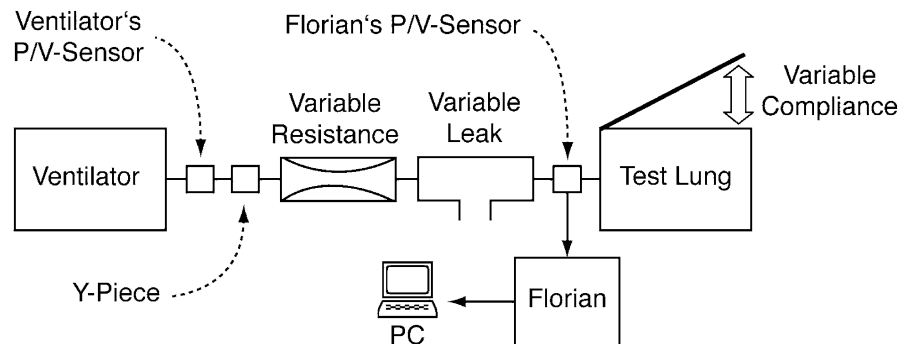

Table 1 Characteristics of tested ventilators: Babylog 8000 plus (Dräger Medical, Lübeck, Germany), Evita XL, (Dräger Medical), Galileo Gold (Hamilton Medical, Rhäzüns, Switzerland), Servo-i (Maquet, Solna, Sweden), SLE 5000 (SLE, South Croydon, UK), and VIP Gold (Bird, Palm Springs, USA) (V_t tidal volume, PIP peak inspiratory pressure, Standard PIP alarm settings see text, NA not applicable, NI no information from user interface, manual, or manufacturer)

	Babylog 8000+	Evita XL	Galileo Gold	Servo-i	SLE 5000	VIP Gold
Type	Continuous flow	Continuous baseflow combined with variable flow	Variable flow	Variable flow	Continuous flow	Continuous flow
Version	NI	Version 5.10	Software version GMP 03.41f, GCP 03.04a, GPT 01.00	NI	Controller hardware 2, software 28	NA
Mode	Synchronized intermittent positive pressure	Neoflow	NA	NA	Continuous mandatory ventilation	Assist control, decelerating flow pattern
Preselection	NA	Infant, preselection	Infant, preselection	Infant, preselection	Infant, preselection	NA
Volume-targeted mode	Volume guarantee	Autoflow	Adaptive pressure ventilation	Pressure-regulated volume Control	Targeted tidal volume	Volume-assured pressure support
Set V_t in preterm/full-term settings (ml)	8/28	8/28	10/28	8/28	8/28	10/25
PIP alarm settings Algorithm details	Standard Exhaled V_t feedbacks PIP of following inflation, maximal PIP set by operator ^a	Standard Inspiratory V_t feedbacks PIP of following inflations ^b	40 cmH ₂ O Calculated dynamic compliance (based on inspiratory V_t) determines PIP of following inflations	Standard Determines dynamic compliance to calculate lowest PIP for following inflations	Standard Controls ongoing V_t by breath-to-breath adjustment of PIP	Standard Inflation starts in pressure, controlled mode switch to flow cycled volume control if V_t not reached
Security feature	Maximal Δ PIP limited, expiratory valve opens when $V_t > 130\%$ of set	Maximal Δ PIP 3 cmH ₂ O in next inflations	NI	Maximal Δ PIP limited to 3 cmH ₂ O, detects overshooting	NI	NI

^a Data provided by manufacturer: Ahluwalia J, Morley C, Wahle HG (2005) Volume guarantee, new approaches in volume controlled ventilation for neonates; ^b Data provided by manufacturer: Fitzgerald J (2005) Autoflow, 20 questions—20 answers

Study protocol

Changes in compliance, airway leak, and resistance were systematically introduced and the delivered V_t was recorded. The various ventilators were compared for their effectiveness in maintaining the desired V_t . All experiments were performed simulating full-term and preterm infant settings. Basic full-term infant settings were: V_t 28 ml, resistance $50 \text{ cmH}_2\text{O l}^{-1} \text{ s}^{-1}$, compliance $4 \text{ ml/cmH}_2\text{O}$, respiratory rate 35 breaths/min, leak 0%, inspiratory time 0.4 s. The following changes were inflicted on the full-term infant system (one parameter change per experiment): (a) compliance change from 4 to 2 ml/cmH₂O, from 2 to 6 ml/cmH₂O, and stepwise from 2 to 4 to 6 ml/cmH₂O, (b) leak change from 30% to 0% and from 0% to 30%, and (c) resistance change from 50 to 200 cmH₂O l⁻¹ s⁻¹ and back to 50 cmH₂O l⁻¹ s⁻¹ and from 50 to 500 cmH₂O l⁻¹ s⁻¹ and back to 50 cmH₂O l⁻¹ s⁻¹ (partial obstruction of the endotracheal tube being simulated in the first and its kinking in the second setting). Basic preterm infant settings were: V_t 8 ml, resistance $50 \text{ cmH}_2\text{O l}^{-1} \text{ s}^{-1}$, compliance $2 \text{ ml/cmH}_2\text{O}$, respiratory rate 50 breaths/min, leak 0%, inspiratory time 0.4 s. The following changes were inflicted on the preterm infant system (one at a time): (a) compliance change from 2 to 1 ml/cmH₂O, from 1 to 4 ml/cmH₂O and stepwise from 1 to 2 to 4 ml/cmH₂O, (b) leak change from 20% to 0% and from 0% to 20%, and (c) resistance change as described above.

In order to isolate the ventilators reaction to any of the above changes only one parameter was changed at a time; all other settings were left at baseline. The compliance and resistance values used were based on lung function testing in healthy and sick infants [19, 20]. All changes were made rapidly from one inflation to the other after observation of a steady state of V_t delivery (generally six inflations in the full-term infant settings and nine inflations in the preterm infant settings were required to achieve this). Only this technique allows us to observe how the ventilators adapt the V_t in response to changes in respiratory mechanics. No further modification were performed during the measurement, neither on the ventilator settings nor in the respiratory system. V_t , PIP, and peak inspiratory flow were recorded for 1 min after each change. Each test series was run five times, and mean values of the measurements were calculated. The standard deviation for delivered V_t was calculated for the five or eight inflations of the steady state before the compliance, resistance, or leak change and for the five or eight final inflations of the measuring period in full-term or preterm infant settings.

The statistical significance of V_t change before and after the inflicted change was tested by one-way analysis of variance for multiple measurements: differences at the level of $p < 0.05$ were considered to be statistically significant.

Ventilators, modes, and settings

Six modern neonatal ventilators were used, defined by its volume-targeted mode: volume guarantee (Babylog 8000, Dräger Medical, Lübeck, Germany), autoflow (Evita XL, Dräger Medical), adaptive pressure ventilation (Galileo Gold, Hamilton Medical, Rhäzüns, Switzerland), pressure-regulated volume control (Servo-i, Maquet, Solna, Sweden), targeted V_t (SLE 5000, SLE, South Croydon, UK), and volume-assured pressure support (VIP Gold, Bird, Palm Springs, USA; see Table 1). The alarms

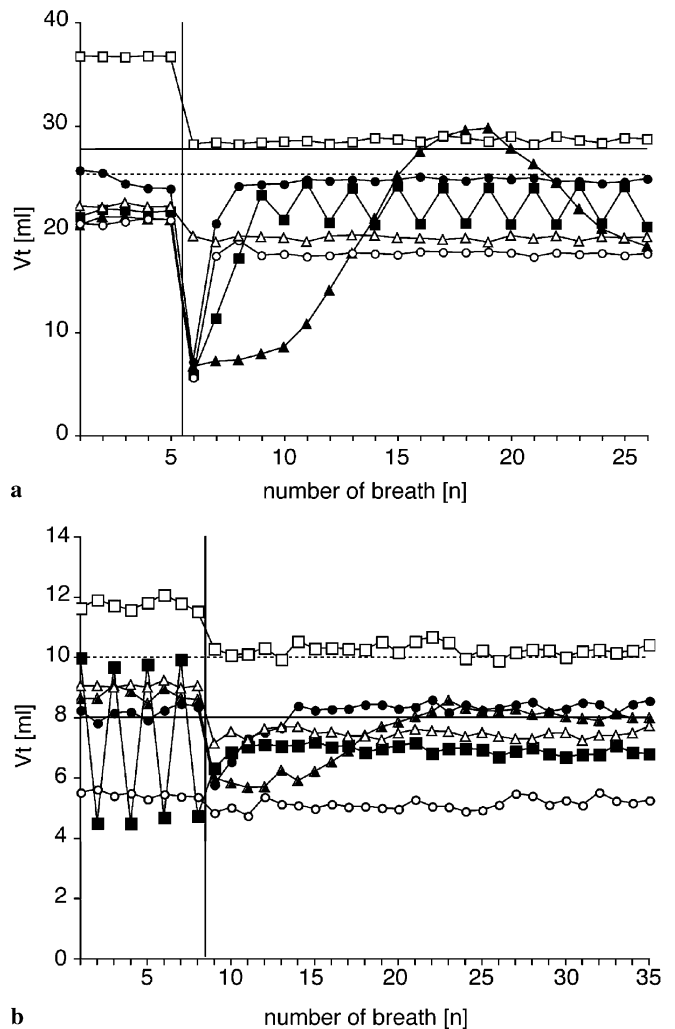

Fig. 2 Compliance decrease from 4 to 2 ml/cmH₂O (2 to 1 ml/cmH₂O) in **a** full-term and **b** preterm infant settings. V_t Tidal volume; horizontal solid bar set V_t of 28 ml (8 ml) in full-term (preterm) infant settings; horizontal dotted bar set V_t of 25 ml (10 ml) for Galileo Gold (Galileo Gold and VIP Gold) ventilator in full-term (preterm) infant settings; vertical bar compliance change before inflation number six (nine) in full-term (preterm) infant settings; filled circles Babylog 8000 plus; filled squares Evita XL; filled triangles Galileo Gold; open circles Servo-i; open squares SLE 5000; open triangles VIP Gold

were set according to the user manual. Where no recommendations were given by the manufacturer, standard alarm settings were used with minimum/maximum V_t alarms at 50%/150% of set V_t , the minimum/maximum minute volume alarm at 50%/150% of the set V_t multiplied with the set respiratory rate, and maximum PIP at 30 cmH₂O. In all machines a positive end-expiratory pressure of 5 cmH₂O was set.

Following the measurements in volume-targeted mode the entire study protocol was run through with all ventilators set on their conventional pressure-controlled modes. Whenever possible the automatic leak compensation was switched off for the following reasons: (a) not all ventilators offered automatic leak compensation, or (b) pilot measurements with automatic leak compensation showed inconsistent breath-to-breath variation in V_t delivery and PIP.

conditions (V_t ranged from 68% to 147% of the set value; Fig. 2, Table 2). All ventilators showed volume undershooting after lowering the compliance, at least during some inflations, under full-term infant settings. The machines varied in the extent of volume undershooting, the number of inflation before reaching a steady state and its adequacy compared to the set V_t value. Compliance decrease was well managed by all machines under preterm infant settings without major changes in delivered V_t compared to baseline conditions. Two ventilators showed a cyclic instability of the delivered V_t : the Evita XL showed breath-to-breath variation after the change (full-term infant settings) and under prechange conditions (preterm infant settings), whereas the Galileo Gold showed a sinusoidal pattern of V_t delivery without achieving a new steady state after the change (full-term infant settings). The VIP Gold and SLE 5000 did not adjust their V_t after the compliance change.

Results

Compliance decrease

Considerable discrepancies between the set V_t and the delivered volumes were observed under prechange

Compliance increase

All ventilators showed volume overshooting above the set value, although to variable extent (Fig. 3, Table 2). The

Table 2 V_t delivery by the various volume-targeted modes before and after compliance decrease and increase of tested ventilators: Babylog 8000 plus (Dräger Medical, Lübeck, Germany), Evita XL, (Dräger Medical), Galileo Gold (Hamilton Medical, Rhäzüns,

Switzerland), Servo-i (Maquet, Solna, Sweden), SLE 5000 (SLE, South Croydon, UK), and VIP Gold (Bird, Palm Springs, USA) (NA: not applicable)

	Babylog 8000+	Evita XL	Galileo Gold	Servo-i	SLE 5000	VIP Gold
Compliance decrease						
Full-term settings ^a						
V_t before the change (% of set V_t) ^b	91 ± 2.5	80 ± 0.8	77 ± 0.8	76 ± 0.7	134 ± 0.1	92 ± 0.5
V_t after the change (% of set V_t) ^c	90 ± 0.4	81 ± 6.4	77 ± 7.0	65 ± 0.3	105 ± 0.7	79 ± 0.5
ΔV_t after/before the change (%) ^d	0	1	NA	-14*	-21*	-13*
Max. volume offset (% of set V_t) ^e	28	23	26	22	103	78
Preterm settings ^f						
V_t before the change (% of set V_t) ^b	102 ± 2.0	90 ± 2.0	87 ± 2.2	68 ± 1.0	147 ± 1.8	91 ± 0.7
V_t after the change (% of set V_t) ^c	105 ± 1.7	86 ± 2.0	80 ± 0.9	66 ± 1.3	128 ± 1.0	75 ± 1.3
ΔV_t after/before the change (%) ^c	3**	-5	-8*	-3**	-13*	-18*
Max. volume offset (% of set V_t) ^e	72	60	57	60	124	72
Compliance increase						
Full-term settings ^g						
V_t before the change (% of set V_t) ^b	91 ± 1.3	83 ± 10.3	68 ± 0.7	67 ± 0.3	104 ± 0.4	81 ± 0.3
V_t after the change (% of set V_t) ^c	82 ± 1.6	80 ± 0.2	75 ± 4.7	80 ± 0.4	140 ± 0.7	97 ± 0.6
ΔV_t after/before the change (%) ^d	-10*	-4	10**	19*	35*	19*
Max. volume offset (% of set V_t) ^e	134	131	163	131	155	101
Preterm settings ^h						
V_t before the change (% of set V_t) ^b	109 ± 1.9	88 ± 1.6	81 ± 3.6	65 ± 2.1	134 ± 1.9	75 ± 0.8
V_t after the change (% of set V_t) ^c	93 ± 2.1	145 ± 1.4	115 ± 0.9	94 ± 1.9	180 ± 1.7	113 ± 0.7
ΔV_t after/before the change (%) ^d	-15*	65*	42*	45*	34*	50*
Max. volume offset (% of set V_t) ^e	187	145	234	146	188	115

* $p < 0.001$, ** $p < 0.05$ vs. prechange V_t ; ^a Target V_t 28/25 ml, compliance decrease from 4 to 2 ml/cmH₂O; ^b Mean ± SD of first five (eight) inflations expressed as proportion of set V_t in full-term (preterm) infant setting; ^c Mean ± SD of last five (eight) inflations expressed as proportion of set V_t in full-term (preterm) infant settings; ^d V_t increase/decrease expressed as proportion of V_t before the change; ^e Highest/lowest V_t expressed as proportion of set V_t ; ^f Target V_t 8/10 ml, compliance decrease from 2 to 1 ml/cmH₂O; ^g Target V_t 28/25 ml, compliance increase from 2 to 6 ml/cmH₂O; ^h Target V_t 8/10 ml, compliance increase from 1 to 4 ml/cmH₂O

ratio between the maximally delivered volume and the set V_t was consistently higher in the low V_t range: under full-term infant settings (compliance change from 2 to 6 ml/cmH₂O) this overshooting ranged from 130% of set V_t (Babylog 8000+, Evita XL, Servo-i) to 163% (Galileo Gold), whereas under preterm infant settings (compliance change from 1 to 4 ml/cmH₂O) it ranged from 115% (VIP Gold) to 234% (Galileo Gold). Between one and 13 inflations were needed for the various machines to achieve a new steady state. The Servo-i, however, overshoot only

once and then lowered the delivered volume significantly for the following inflation before approaching the new steady state by small V_t increments from one inflation to the other. The Evita XL showed again breath-to-breath variability under prechange full-term infant settings, and the VIP Gold as well as the SLE 5000 showed only minimal V_t adjustment after the change. The same pattern of volume overshooting was observed (although to a lesser extent) when the compliance was increased stepwise (data not shown).

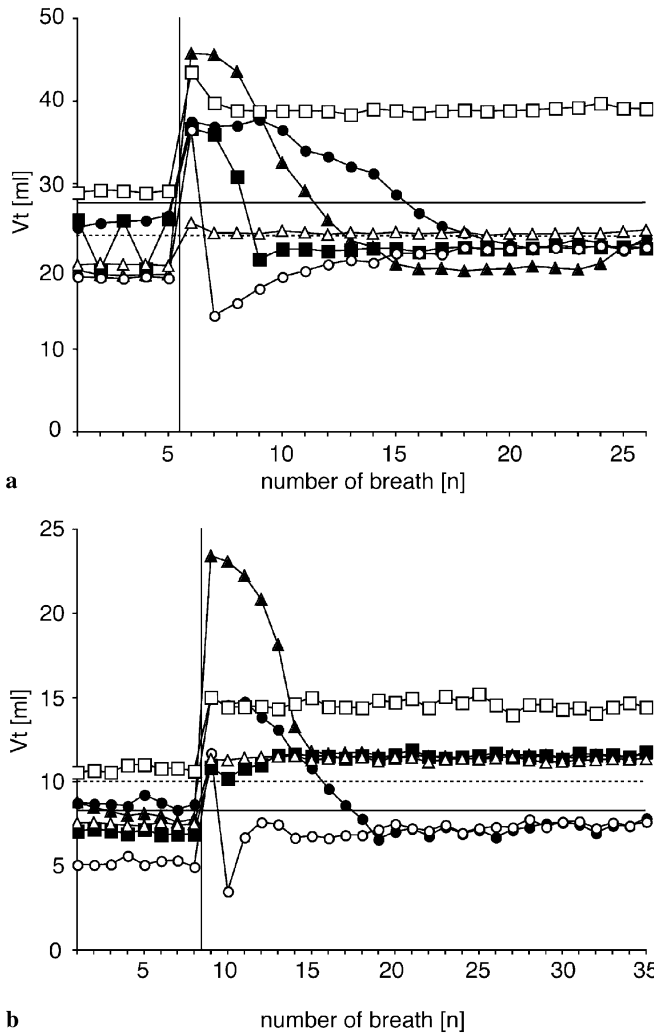

Fig. 3 Compliance increase from 2 to 6 ml/cmH₂O (1 to 4 ml/cmH₂O) in **a** full-term and **b** preterm infant settings. V_t Tidal volume; *horizontal solid bar*: set V_t of 28 ml (8 ml) in full-term (preterm) infant settings; *horizontal dotted bar* set V_t of 25 ml (10 ml) for Galileo Gold (Galileo Gold and VIP Gold) ventilator in full-term (preterm) infant settings; *vertical bar* compliance change before inflation number six (nine) in full-term (preterm) infant settings; *filled circles* Babylog 8000 plus; *filled squares* Evita XL; *filled triangles* Galileo Gold; *open circles* Servo-i; *open squares* SLE 5000; *open triangles* VIP Gold

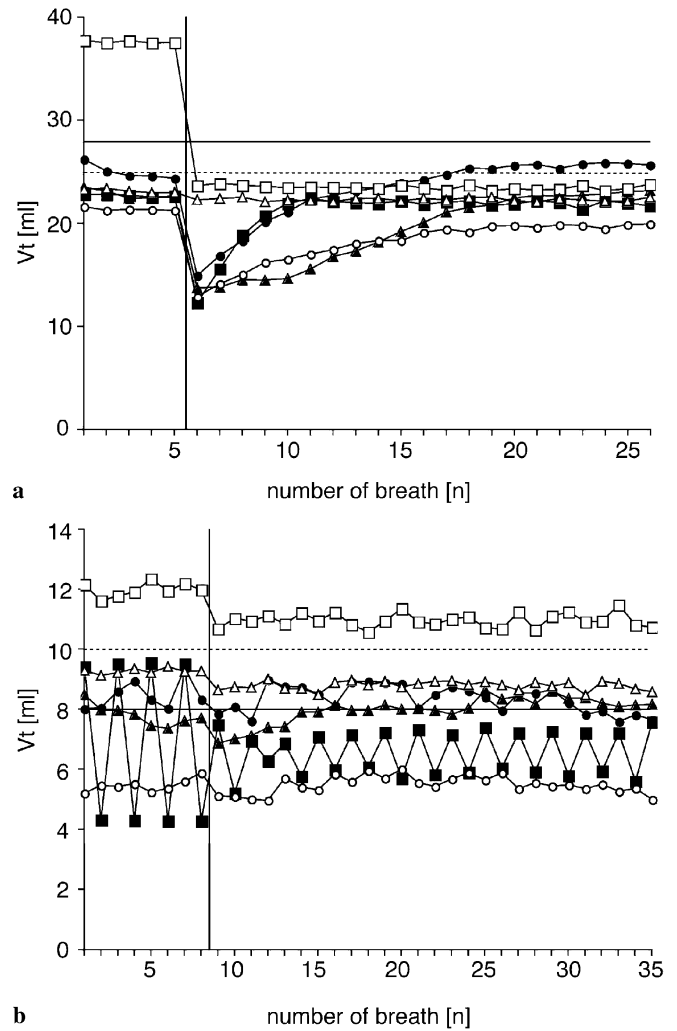

Fig. 4 Resistance increase from 50 to 200 cmH₂O l⁻¹ s⁻¹ in **a** full-term and **b** preterm infant settings. V_t Tidal volume; *horizontal solid bar* set V_t of 28 ml (8 ml) in full-term (preterm) infant settings; *horizontal dotted bar* set V_t of 25 ml (10 ml) for Galileo Gold (Galileo Gold and VIP Gold) ventilator in full-term (preterm) infant settings; *vertical bar* compliance change before inflation number six (nine) in full-term (preterm) infant settings; *filled circles* Babylog 8000 plus; *filled squares* Evita XL; *filled triangles* Galileo Gold; *open circles* Servo-i; *open squares* SLE 5000; *open triangles* VIP Gold

Leak changes

Leak increase or decrease was generally well managed by most ventilators, and we observed only minor variations in V_t delivery. For a more detailed description of these results see Electronic Supplementary Material (ESM; Fig. 1, 2, Table 1).

Resistance increase

All ventilators dropped their V_t for the first inflations after the resistance increase (Fig. 4 and Table 3 show results of the 50 to 200 $\text{cmH}_2\text{O l}^{-1} \text{s}^{-1}$ increase; for data on the 50 to 500 $\text{cmH}_2\text{O l}^{-1} \text{s}^{-1}$ increase see ESM). This drop was less pronounced with the lower set V_t (minimal volume 45–50% under full-term infant settings for the majority of machines and 65–87% under preterm infant settings). Most ventilators adapted the delivered volume to prechange level within 3–14 inflations. The VIP Gold showed only minor V_t variation whereas the SLE did not adapt its volume to the new condition. Under preterm infant settings the Evita XL again demonstrated the

described breath-to-breath V_t variability, before and after the change.

Resistance decrease

All ventilators delivered lower than set V_t under high resistance conditions in full-term infant settings, whereas the V_t was more adequately achieved in preterm infant settings (Fig. 5 and Table 3 show results of the 200 to 50 $\text{cmH}_2\text{O l}^{-1} \text{s}^{-1}$ increase; for data on the 500 to 50 $\text{cmH}_2\text{O l}^{-1} \text{s}^{-1}$ increase see ESM). All machines except the VIP Gold overshoot the delivered volume above the set value in full-term infant settings, with a maximal volumes ranging from 119% of the set value (Servo-i) to 173% (Galileo Gold). The Servo-i behaved in the same way as after the compliance increase and administered only one inflation above the set value, lowered significantly the delivered V_t for the following inflation before approaching a steady state close to the set value by small breath-to-breath volume increments. Under preterm infant settings the delivered volume of all ventilators increased after resistance decrease but to a lesser extent than under

Table 3 V_t delivery by the various volume-targeted modes before and after resistance increase and decrease of tested ventilators: Babylog 8000 plus (Dräger Medical, Lübeck, Germany), Evita XL, (Dräger Medical), Galileo Gold (Hamilton Medical, Rhäzüns,

Switzerland), Servo-i (Maquet, Solna, Sweden), SLE 5000 (SLE, South Croydon, UK), and VIP Gold (Bird, Palm Springs, USA) (NA not applicable)

	Babylog 8000+	Evita XL	Galileo Gold	Servo-i	SLE 5000	VIP Gold
Resistance increase						
Full-term settings ^a						
V_t before the change (% of set V_t) ^b	89 ± 1.9	81 ± 0.3	81 ± 1.4	76 ± 0.4	134 ± 0.3	93 ± 0.6
V_t after the change (% of set V_t) ^c	92 ± 0.6	78 ± 0.9	82 ± 0.7	71 ± 0.5	84 ± 0.8	89 ± 0.5
ΔV_t after/before the change (%) ^d	3	-4**	0	-7**	-38**	-4**
Max. volume offset (% of set V_t) ^e	53	44	49	46	84	89
Preterm settings ^f						
V_t before the change (% of set V_t) ^b	106 ± 4.8	86 ± 32.7	78 ± 3.3	68 ± 1.9	150 ± 2.3	93 ± 0.8
V_t after the change (% of set V_t) ^c	101 ± 4.1	82 ± 9.4	83 ± 1.7	67 ± 1.6	138 ± 2.8	88 ± 1.7
ΔV_t after/before the change (%) ^d	-5	-5	6*	-2	-8**	-6**
Max. volume offset (% of set V_t) ^e	98	65	69	62	134	87
Resistance decrease						
Full-term settings ^g						
V_t before the change (% of set V_t) ¹	84 ± 1.5	78 ± 0.3	83 ± 0.4	67 ± 0.8	84 ± 0.4	89 ± 0.6
V_t after the change (% of set V_t) ²	84 ± 1.2	81 ± 0.6	77 ± 3.4	77 ± 0.4	134 ± 0.7	92 ± 0.2
ΔV_t after/before the change (%) ³	1	3**	-7*	14**	59**	3**
Max. volume offset (% of set V_t) ⁴	130	125	173	119	137	91
Preterm settings ^h						
V_t before the change (% of set V_t) ^b	105 ± 3.3	84 ± 14.3	86 ± 1.2	63 ± 1.3	136 ± 2.2	85 ± 1.5
V_t after the change (% of set V_t) ^c	107 ± 1.9	88 ± 31.3	88 ± 8.5	72 ± 1.8	148 ± 2.2	91 ± 1.2
ΔV_t after/before the change (%) ^d	1	5	NA	14**	9**	6**
Max. volume offset (% of set V_t) ^e	119	118	99	76	155	92

* $p < 0.001$, ** $p < 0.05$ vs. prechange V_t ; ^a Target V_t 28/25 ml, resistance increase from 50 to 200 $\text{cmH}_2\text{O l}^{-1} \text{s}^{-1}$; ^b Mean ± SD of first five (eight) inflations expressed as proportion of set V_t in full-term (preterm) infant setting; ^c Mean ± SD of last five (eight) inflations expressed as proportion of set V_t in full-term (preterm) infant settings; ^d V_t increase/decrease expressed as proportion of V_t before the change; ^e Highest/lowest V_t expressed as proportion of set V_t ; ^f Target V_t 8/10 ml, resistance increase from 50 to 200 $\text{cmH}_2\text{O l}^{-1} \text{s}^{-1}$; ^g Target V_t 28/25 ml, resistance decrease from 200 to 50 $\text{cmH}_2\text{O l}^{-1} \text{s}^{-1}$; ^h Target V_t 8/10 ml, resistance decrease from 200 to 50 $\text{cmH}_2\text{O l}^{-1} \text{s}^{-1}$

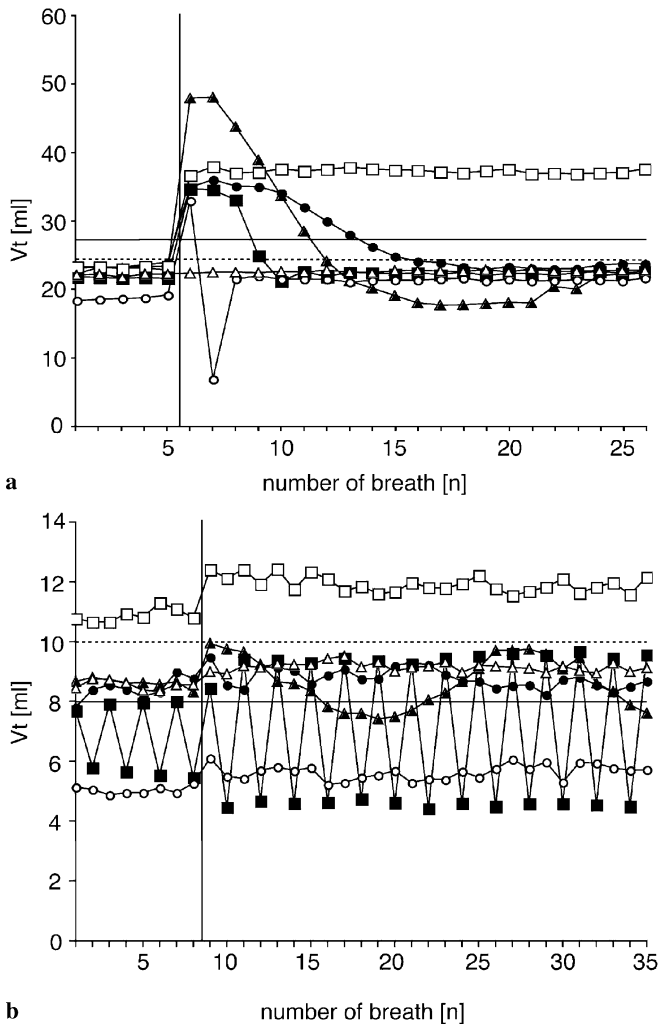

Fig. 5 Resistance decrease from 200 to 50 $\text{cmH}_2\text{O l}^{-1} \text{s}^{-1}$ in **a** full-term and **b** preterm infant settings. V_t Tidal volume; *horizontal solid bar* set V_t of 28 ml (8 ml) in full-term (preterm) infant settings; *horizontal dotted bar* set V_t of 25 ml (10 ml) for Galileo Gold (Galileo Gold and VIP Gold) ventilator in full-term (preterm) infant settings; *vertical bar* compliance change before inflation number six (nine) in full-term (preterm) infant settings; *filled circles* Babylog 8000 plus; *filled squares* Evita XL; *filled triangles* Galileo Gold; *open circles* Servo-i; *open squares* SLE 5000; *open triangles* VIP Gold

full-term infant settings. The Evita XL, however, again showed the described breath-to-breath variability, the Servo-i delivered V_t well below the set value before and after the change, and the Galileo Gold started a sinusoidal pattern of volume delivery with the resistance decrease (V_t between 7 and 10 ml; set value 10 ml). There was of course no volume adaptation in any of the pressure-control modes in any of the above settings (data not shown).

Discussion

Published data on the stability of V_t delivery during volume-targeted ventilation are conflicting [6, 7, 12, 14, 17]. The aim of this study was to evaluate how the ventilators algorithms manage to stabilize the delivered V_t after deliberately rapid modifications in respiratory mechanics. The most important observation was that important volume overshooting occurred in all ventilators after compliance increase and resistance decrease (Figs. 3, 5; Tables 2, 3). The difference between the tested machines can be found in the degree of volume overshooting, the response time needed to bring the V_t back to baseline, the ability to achieve a steady state at the set value, and the way in which these changes were handled by the built-in algorithm. The most alarming observations were made under “preterm infant” test conditions (i. e., set V_t of 8 and 10 ml, respectively). After compliance increase one ventilator overshoot the V_t up to 234% of set value and others up to 190%. Only the Evita XL, Servo-i, and VIP Gold kept their V_t within the 150% range, which might be considered to be acceptable in the clinical setting. The Evita XL, VIP Gold, and SLE 5000 behaved as in a pressure-control mode, without lowering V_t towards the set value after the initial overshoot; the Galileo Gold and Babylog 8000 plus needed 7–11 inflations to reach steady state again at acceptable V_t . The Servo-i had the quickest response time and showed a unique particularity in its algorithm. Delivered V_t is lowered dramatically after the first overshoot inflation; there was then a trend in V_t values toward baseline by small volume adjustments. This is a very safe way to react to volume overshooting. Most other machines delivered too high V_t after these changes. The same pattern can be observed in “full-term infant” conditions (i. e., set V_t of 28 or 25 ml) after compliance increase. Under this condition only the Galileo Gold and SLE 5000 showed more than 150% volume overshooting. V_t after resistance decrease increased to 182% (Galileo Gold) of set values, but most ventilators did not overshoot to more than 40 ml. Our results are consistent with the findings of an unpublished bench study comparing the Babylog 8000 plus with the VIP Gold that observed variable volume overshooting as well [17].

The lower than set V_t delivery was transient with most ventilators after compliance decrease and resistance increase in preterm and full-term infant settings (Figs. 2, 4; Tables 2, 3). However, the transient tendency to deliver lower than set V_t is of less clinical concern. The final adaptation of V_t in volume-targeted modes can be pointed out as a clear advantage over conventional pressure control modes since the latter continues to deliver a low V_t until the operator adjusts the PIP manually. Leak changes (up or downwards) were generally well handled by all

ventilators, and only minor changes in V_t delivery were noted (see ESM, Figs. 1, 2, Table 1).

With some settings considerable V_t discrepancy from the set value was observed after the inflected change but even under baseline conditions. This may be due to any of several factors, including a flow sensor not located at the Y-piece (as in the Servo-i) and differences in flow algorithms applied. Under low compliance and high resistance settings the inadequate V_t delivery may be due to the discrepancy of the respiratory system's time constant and the set inspiratory time of 0.4 s. This hypothesis is supported by the absence of a high PIP alarm in most ventilators. We chose this inspiratory time as it is a classical setting in many neonatal care units, and we elected not to adapt this setting after the changes as this rarely happens in daily practice.

Some ventilators showed considerable variation in delivered V_t , which seems to be a result of the volume adjustment algorithm used. The Evita XL showed a breath-to-breath variability of $\pm 25\%$ around the set value. This variability was abolished or attenuated under high resistance and low compliance settings. This may be due to the fact that the Evita XL's algorithm adjusts PIP by steps of 3 cmH₂O in order to match the expiratory V_t with the set value. In conditions with low resistance and high compliance this leads to a falsely high volume, which triggers the feedback decrease in PIP that leads to a V_t lower than the target volume and so on. The Galileo Gold showed a sinusoidal pattern of V_t delivery after compliance decrease (set V_t of 28 ml), leak changes (set V_t of 10 ml) and resistance decrease (set V_t of 10 ml), which may be due to the fact that its algorithm targets the set V_t over a longer period of time by progressive PIP increases or decreases.

There are differences in the way in which the various ventilators target the V_t . The details of the algorithms are part of the manufacturers art to build respirators and they are therefore not available for all machines (Table 1). These vary substantially between the various

machines tested in this study. It would be helpful for the clinician to have easy access to the ventilator algorithms in detail in order to decide whether a specific patient can be considered eligible for this ventilation mode and to take appropriate bedside decisions. Short-term ventilation with high V_t has been clearly shown to be detrimental to the patients lung [21]. Large V_t (certainly if higher than 9 ml/kg) can lead to overdistension [22] and increased incidence of acute lung injury [23]. However, there is to our knowledge no evidence concerning the adverse effect of acute application of high V_t (if not excessive [24]) for only a few inflations and no critical threshold can therefore be determined above which lung injury may be worsened. The settings chosen in our study may not reflect clinical situations completely; some changes were more rapid and some of them extremer than those commonly encountered at the bedside. However, these artificial events allowed us to isolate the exact way the various ventilator algorithms deal with changes in respiratory mechanics and help us to better understand the patient-ventilator interaction in this relatively new ventilation mode. In addition, we believe that the extent of volume overshooting that we observed under some circumstances can be of clinical concern, even if the high V_t is applied for only a short period of time.

In conclusion, using volume-targeted mode some ventilators showed important V_t overshooting upon rapid changes in respiratory mechanics (i. e., compliance increase or resistance decrease) that may be of clinical concern. Some ventilators did not achieve the set V_t after compliance decrease or resistance increase, which may lead to inadvertent hypoventilation. Therefore clinical studies are needed to determine the significance of our observations from the bench to determine complication rate and patient outcome with this relatively new ventilator mode. We also encourage manufacturers to further improve their ventilator algorithms governing volume delivery in volume-targeted modes.

References

1. Clark RH, Gerstmann DR, Jobe AH, Moffitt ST, Slutsky AS, Yoder BA (2001) Lung injury in neonates: causes, strategies for prevention, and long-term consequences. *J Pediatr* 139:478–486
2. Chiumello D, Pristine G, Slutsky AS (1999) Mechanical ventilation affects local and systemic cytokines in an animal model of acute respiratory distress syndrome. *Am J Respir Crit Care Med* 160:109–116
3. Network TARDS (2000) Ventilation with lower tidal volumes as compared with traditional tidal volumes for acute lung injury and the acute respiratory distress syndrome. The Acute Respiratory Distress Syndrome Network. *N Engl J Med* 342:1301–1308
4. Keszler M (2005) Volume-targeted ventilation. *J Perinatol* (Suppl 2) 25:S19–S22
5. Lista G, Marangione P, Azzali A, Castoldi F, Pogliani L, Compagnoni G (2000) [The “guaranteed volume” in pressure support ventilation reduces the risk of barotrauma in premature children with severe respiratory syndrome]. *Acta Biomed Ateneo Parmense* (Suppl 1) 71:453–456
6. Abubakar KM, Keszler M (2001) Patient-ventilator interactions in new modes of patient-triggered ventilation. *Pediatr Pulmonol* 32:71–75

7. Lista G, Colnaghi M, Castoldi F, Condo V, Reali R, Compagnoni G, Mosca F (2004) Impact of targeted-volume ventilation on lung inflammatory response in preterm infants with respiratory distress syndrome (RDS). *Pediatr Pulmonol* 37:510–514
8. Herrera CM, Gerhardt T, Claure N, Everett R, Musante G, Thomas C, Bancalari E (2002) Effects of volume-guaranteed synchronized intermittent mandatory ventilation in preterm infants recovering from respiratory failure. *Pediatrics* 110:529–533
9. Keszler M, Abubakar K (2004) Volume guarantee: stability of tidal volume and incidence of hypocarbia. *Pediatr Pulmonol* 38:240–245
10. Mrozek JD, Bendel-Stenzel EM, Meyers PA, Bing DR, Connett JE, Mammel MC (2000) Randomized controlled trial of volume-targeted synchronized ventilation and conventional intermittent mandatory ventilation following initial exogenous surfactant therapy. *Pediatr Pulmonol* 29:11–18
11. Sinha SK, Donn SM, Gavey J, McCarty M (1997) Randomised trial of volume controlled versus time cycled, pressure limited ventilation in preterm infants with respiratory distress syndrome. *Arch Dis Child Fetal Neonatal Ed* 77:F202–205
12. Piotrowski A, Sobala W, Kawczynski P (1997) Patient-initiated, pressure-regulated, volume-controlled ventilation compared with intermittent mandatory ventilation in neonates: a prospective, randomised study. *Intensive Care Med* 23:975–981
13. Cheema IU, Ahluwalia JS (2001) Feasibility of tidal volume-guided ventilation in newborn infants: a randomized, crossover trial using the volume guarantee modality. *Pediatrics* 107:1323–1328
14. Lista G, Colnaghi M, Castoldi F, Fontana P, Reali R, Mosca F, Compagnoni G (2003) [Lung injury and ventilatory strategies]. *Pediatr Med Chir* 25:35–41
15. McCallion N, Davis PG, Morley CJ (2004) Volume-targeted versus pressure-limited ventilation in the neonate. *Cochrane Database of Systematic Reviews*, Cochrane Library
16. Riley C, Pilcher J (2003) Volume-guaranteed ventilation. *Neonatal Netw* 22:17–22
17. Collins E, Faciane V, Abbruzzese L (2005) Comparison of Bird Vip Gold ventilator in conventional volume mode to Drager Babylog 8000 Plus in volume guarantee mode a bench study. http://www.viasyshealthcare.com/prod_serv/downloads/045_Volume_Accuracy_Monograph.pdf; accessed 18 September
18. Scalfaro P, Pillow JJ, Sly PD, Cotting J (2001) Reliable tidal volume estimates at the airway opening with an infant monitor during high-frequency oscillatory ventilation. *Crit Care Med* 29:1925–1930
19. Hjalmarson O, Sandberg K (2002) Abnormal lung function in healthy preterm infants. *Am J Respir Crit Care Med* 165:83–87
20. Kavvadia V, Greenough A, Itakura Y, Dimitriou G (1999) Neonatal lung function in very immature infants with and without RDS. *J Perinat Med* 27:382–387
21. Dreyfuss D, Saumon G (1998) Ventilator-induced lung injury: lessons from experimental studies. *Am J Respir Crit Care Med* 157:294–323
22. Roupie E, Dambrosio M, Servillo G, Mentec H, el Atrous S, Beydon L, Brun-Buisson C, Lemaire F, Brochard L (1995) Titration of tidal volume and induced hypercapnia in acute respiratory distress syndrome. *Am J Respir Crit Care Med* 152:121–128
23. Gajic O, Dara SI, Mendez JL, Adesanya AO, Festic E, Caples SM, Rana R, St Sauver JL, Lymp JF, Afessa B, Hubmayr RD (2004) Ventilator-associated lung injury in patients without acute lung injury at the onset of mechanical ventilation. *Crit Care Med* 32:1817–1824
24. Bjorklund LJ, Ingimarsson J, Curstedt T, John J, Robertson B, Werner O, Vilstrup CT (1997) Manual ventilation with a few large breaths at birth compromises the therapeutic effect of subsequent surfactant replacement in immature lambs. *Pediatr Res* 42:348–355