

Wood Sci Technol (2012) 46:927–938  
DOI 10.1007/s00226-011-0449-4

ORIGINAL

# Moisture-dependent orthotropic elasticity of beech wood

Stefan Hering · Daniel Keunecke · Peter Niemz

Received: 28 October 2010 / Published online: 1 November 2011  
© Springer-Verlag 2011

**Abstract** Elastic material properties are one of the most important material characteristics in mechanical modelling. Wood with distinctively different properties in the longitudinal, radial and tangential directions exhibits a strong moisture-dependent material characteristic in the elastic range. In order to characterise beech wood as an orthotropic material, all of the independent elastic properties were determined at different moisture conditions. These characteristic properties have never been determined before as a function of moisture content yet are vital to the field of wood modelling. All elastic parameters, except for some Poisson's ratios, show a decrease in stiffness with increasing moisture content. In comparison to available literature references at a moisture content of  $\omega \approx 12\%$ , the identified values were of the same order of magnitude. The determined material properties can be used to investigate the mechanical behaviour of beech wood structures including different moisture conditions.

## Introduction

The elasto-mechanical characterisation of wood based on a three-dimensional approach is needed as input for ambitious calculations in such fields like civil engineering and material science. It is usually given by a symmetric and orthotropic material description and is basically built up out of nine (resp. twelve) independent components. Hörig (1933), Keylwerth (1951) or Bodig and Jayne (1993) summarised the theoretical background of orthotropic elasticity in wood. In many literature references, a combination of experimentally determined elastic properties is described (Stamer and Sieglerschmidt 1933; Stamer 1935; Hörig 1935; Keylwerth 1951; Kollmann 1951; Guitard and Amri 1987; Bodig and Jayne 1993; Pozgaj et al. 1993;

---

S. Hering (✉) · D. Keunecke · P. Niemz  
Institute for Building Materials (Wood Physics), ETH Zurich, 8093 Zurich, Switzerland  
e-mail: shering@ethz.ch

Niemz 1993; Keunecke et al. 2008). However, significantly less is known about the moisture dependency of the elastic properties. One example is given by Neuhaus (1983) for spruce wood, where all components of the compliance matrix were determined for eight different moisture levels.

For beech wood, the most comprehensive investigation of moisture-dependent elasticity was carried out by Wommelsdorf (1966), but unfortunately not as a full set of compliance parameters. Further properties were presented by Neumann (1998) but with little information on moisture and also not as a complete set of elastic properties.

Since the authors' concern is a moisture-dependent orthotropic material description, all of the required compliance parameters at different moisture states for this study were determined by combined compression and ultrasonic testing. Young's moduli and Poisson's ratios were derived from compression tests. In contrast to diverse mechanical or inductive measurement devices (Stamer and Sieglerschmidt 1933; Neuhaus 1981; Niemz and Caduff 2008), strain information is obtained by means of a non-contact optical surface deformation measurement method based on digital image correlation (DIC) as already used in a previous study (Keunecke et al. 2008).

To quantify the shear moduli, different measurement techniques are reported in literature. Static tests with a torsion pendulum (Stamer and Sieglerschmidt 1933; Grimsel 1999), the Iosipescu-Test (Iosipescu 1967; Dumail et al. 2000) or the Arcan-Test (Arcan et al. 1978; Dahl and Malo 2009a, b) were frequently used. In this study, however, an acoustic method (ultrasound velocity measuring) was carried out (Bucur and Archer 1984). Due to the small specimen dimensions, orthogonal material directions along the cubic specimen edges were feasible. Furthermore, the simple and flexible measurement procedure enables testing in environments with different climatic conditions. Combining the static and dynamic measurement techniques mentioned, the main goals of this study are thus

- to evaluate the three-dimensional elastic behaviour of beech wood
- to determine the influence of the moisture content on the elastic properties
- to visualise moisture dependence and to verify the assumed symmetry of the compliance matrix.

## Materials and methods

### Specimens

The compression test samples were prepared from European beech (*Fagus sylvatica* L.) grown in Switzerland near Zurich from solely clear specimens (free of knots, tension wood and red heartwood). In order to minimise the friction dependence of the material parameters, the strains were measured in the middle of the specimens and as far as possible from the specimen–clamp interfaces (Diot et al. 2008; van Mier 1997). Normally, cylindrical specimens are used but for the measurement of Poisson's ratios for an orthotropic material, the specimen shape shown in Fig. 1 is

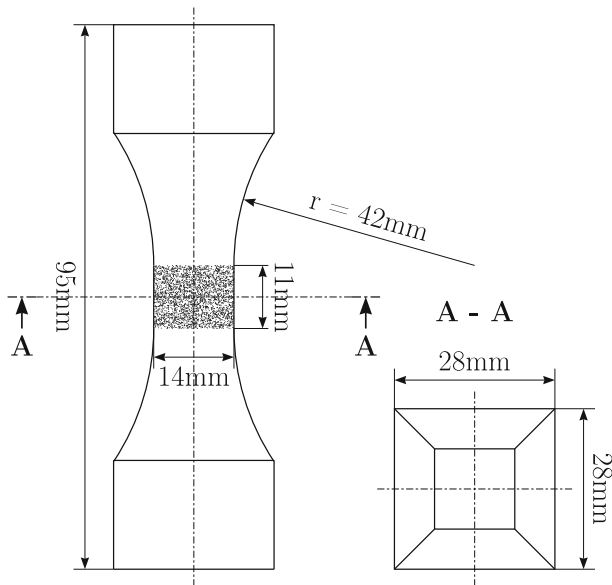

**Fig. 1** Waisted specimen with random texture used for compression testing

more appropriate. The cross-sectional area in the narrow specimen section was  $14 \text{ mm} \times 14 \text{ mm}$  with parallel specimen surfaces with a length of 11 mm in the load direction. The matching of the specimen coordinate system and the principle orientation of the wooden material in the load area was ensured. The specimens were divided into four groups with 15–25 samples per load axes *L*, *R* and *T*. After specimen preparation in standard climatic conditions at  $20^\circ\text{C}$  and 65% relative humidity (RH), each group was climatized at a different relative humidity (35, 65, 85, 95%) and a temperature of  $20^\circ\text{C}$ .

### Speckle pattern

A high-contrast random dot texture (‘speckle pattern’) was sprayed on two adjacent sides of the waisted specimen section (Fig. 1). These patterns were needed for the evaluation of strains at the specimen surface during compression testing by means of DIC software. The texture generation and the used strain measurement equipment are explained in detail in Keunecke et al. (2008).

### Compression test

After the specimens reached equilibrium moisture content, compression tests were performed using a Zwick Z10 universal testing machine with a 10 kN load cell. A flexible joint was used to avoid bending and to compensate for possible non-parallel planes due to small dimensional changes as a result of climatization. The load rate was defined such that the maximum load would theoretically be reached in 90

( $\pm 30$ ) s. The compression tests (displacement-controlled via a constant cross-head load rate) were carried out in standard climatic conditions and with only small strains in the linear elastic range. Hence, each specimen was taken out of its specific ambient climate and immediately tested. The respective Young's moduli  $E$  was calculated according to the ratio of the stress  $\sigma$  to the corresponding strain  $\varepsilon$  by

$$E_i = \frac{\Delta\sigma_i}{\Delta\varepsilon_i} = \frac{\sigma_{i,2} - \sigma_{i,1}}{\varepsilon_{i,2} - \varepsilon_{i,1}} \quad i \in R, L, T. \quad (1)$$

To maximise the evaluation range in the elastic region, the specified stress boundaries  $\sigma_{i,1}$  and  $\sigma_{i,2}$  varied from 0.5...1.5 MPa for the determination of  $E_T$  over 1...3 MPa for  $E_R$  up to 5...15 MPa for  $E_L$ . In a subsequent post-processing step, the optically recorded deformations were used to calculate two strain components by means of a cross-correlation algorithm: applying the active strain component  $\varepsilon_j$  in the load direction and the passive (lateral) strain component  $\varepsilon_i$ . The negative ratio is given by

$$v_{ij} = -\frac{\varepsilon_i}{\varepsilon_j}, \quad i, j \in R, L, T \text{ and } i \neq j \quad (2)$$

and is known as Poisson's ratio  $\nu$  and can be determined by a linear regression of the passive–active strain diagram. After the compression tests, a cuboid section was cut out of the undeformed region of the specimen, climatised at 20°C and 65% RH and subsequently oven-dried to determine the moisture content and the density of the sample (Niemz 1993). In all following tables, the densities are given for standard climate conditions.

### Ultrasound testing

The sound velocity measurements were carried out with an EPOCH XT (Panametrics) ultrasonic flaw detector, which was used with transverse waves in transmission mode. The coupling between transducer (1 MHz) and sample was realised with a gel-like coupling medium (Ultrage II). Cubic specimens with orthotropic material directions parallel to the sample edges were prepared: 40 main specimens for velocity measurements and 40 twin specimens for the determination of the moisture content via the gravimetric method for every specific climate condition. This was necessary due to irreversible falsification of the wood mass by means of the couplant penetrating into the cell cavities during the velocity measurements. The 40 main cubes were classified into four groups with ten specimens each, with edges of 8, 10, 12 and 14 mm length. This procedure enables the direct analysis of the ultrasound velocity  $c$  by a simple linear regression. Afterwards, the respective shear moduli  $G$  were derived taking into consideration the moisture-dependent raw density  $\rho$  by applying

$$G_{ij} = c_{ij}^2 \rho, \quad i, j \in R, L, T \text{ and } i \neq j. \quad (3)$$

By measuring all six acoustic properties, an additional comparison between the corresponding values with interchanged indexes was possible.

## Results and discussion

### Young's moduli

Table 1 provides an overview of the determined moisture-dependent Young's moduli of European beech. The varying number of analysed specimens is a combined result of the varying number of available samples in the three material directions and rejected outliers identified in a statistical test (DIN V 65352 1987). However, the number of  $n \geq 14$  per test series yields a rather low coefficient of variation (CoV) for the Young's moduli. In general, all anatomical directions show a significant decrease in stiffness with increasing moisture content.

A comparison with literature references (as summarised in Table 2) reveals that the identified values obtained in standard climatic conditions (20°C, 65% RH) are of the same order of magnitude, even with low values for the tangential moduli caused by the low densities of these specimens. Literature values are based on slightly lower moisture contents causing higher stiffness. Moreover, the different raw densities affect the material properties and have to be considered when making a direct comparison. The experimental method is a further influencing factor. The longitudinal values stated by Bucur and Archer (1984) are remarkably low; values determined with dynamic methods are usually higher than those determined with static tests (Bucur 1995; Keunecke et al. 2007).

### Poisson's ratios

An example of typical measurement data and application of the linear regression to evaluate the Poisson's ratios are illustrated in a previous study (Keunecke et al. 2008). To ensure a high validity of the measurements, only data sets with a

**Table 1** Moisture-dependent Young's moduli of European beech determined under compression

Load direction	Number of specimen $n$ (–)	Moisture content $\omega$ (%)	Density $\rho$ (kg/m <sup>3</sup> )	Young's moduli $E$ (MPa)	Coefficient of variation CoV (%)
<i>R</i>	14	8.7	724	1,990	10.2
	17	12.9	713	1,900	11.3
	17	16.4	726	1,570	8.9
	18	18.6	717	1,430	7.4
<i>L</i>	18	8.7	705	14,400	12.2
	17	12.3	740	13,900	11.2
	15	15.9	716	13,200	9.8
	16	17.9	707	11,600	15.5
<i>T</i>	21	8.7	621	679	10.8
	23	12.1	621	606	8.3
	21	16.3	626	505	7.1
	20	17.4	622	475	7.7

**Table 2** Moisture-dependent Young's moduli of European beech; comparison of mean values at 12.5% moisture content and literature references

References	Density $\rho$ (kg/m <sup>3</sup> )	Moisture content $\omega$ (%)	Young's moduli (MPa)		
			$E_L$	$E_R$	$E_T$
Measurements of this study	691	12.5	13,900	1,900	610
Stamer and Sieglerschmidt (1933)	745	10.5	13,700	2,240	1,140
Wommelsdorf (1966)	–	8.2	11,100	2,070	1,070
Neumann (1998)	–	12	–	1,100	580
Bucur and Archer (1984) (0.5 MHz)	674	–	9,560	1,490	880
Bucur and Archer (1984) (1 MHz)	674	–	9,160	1,850	1,040
Pozgaj et al. (1993)	684 <sup>a</sup>	10–12	16,800	1,590	610
Hearmon and Barkas (1941)	750	12	11,900	1,700	1,030

<sup>a</sup> Oven-dry density

coefficient of correlation  $r^2 \geq 0.9$  were summarised, which explains the varying number of specimens. Only a fraction of the tested samples provided usable results, especially when the longitudinal material direction corresponded to the passive lateral strain component. This is a well-known problem in material testing (Bodig and Jayne 1993). This low number of analysed specimens is expressed by the high coefficient of variation for those samples, which is summarised in Table 3 for all material directions and four moisture contents. Although statistical significance is reduced, real values were obtained. In contrast to the common procedure of calculating these values under the assumption of material symmetries (Bodig and Jayne 1993; Garab et al. 2010), the measurement approach enables a discussion of the mentioned symmetries. Even though approximately 20 specimens per orientation were tested, all directions show a high coefficient of variation, except those in the *RT* plane. Considering the high coefficient of correlation for every single specimen, a high natural variance of the Poisson's ratios in the *LT* and *LR* planes is implied. In Table 3 the Poisson's ratios are presented for samples with different moisture contents. Except for the values of  $v_{rt}$ , an increase in moisture content results in a slight decrease in Poisson's ratios, with the major changes occurring in the longitudinal lateral contraction.

In general, all determined ratios are in the range of their respective literature values (Table 4) with the exception of the low Poisson's ratios with longitudinal load direction. Differences in the nature of load, such as tension and bending as in Wommelsdorf (1966), or alternative test methods as in Grimsel (1999) or simply a very low number of specimens as in Stamer and Sieglerschmidt (1933) complicate a comparison.

### Shear moduli

The approach to determine the shear moduli on the basis of a linear regression is exemplarily shown in Fig. 2 for measurement data in the *RT* plane. The presumed similarity in the corresponding measurement directions *RT/TR*, *LT/TL* and *LR/RL*

**Table 3** Moisture-dependent Poisson's ratios of European beech determined under compression (left values correspond to left Poisson's ratio/right values correspond to right Poisson's ratio)

Load direction <sup>a</sup>	Contraction direction	Number of specimen <i>n</i> (–)	Moisture content $\omega$ (%)	Density $\rho$ (kg/m <sup>3</sup> )	Poisson's ratio			Coefficient of variation CoV (%)
					$\nu_{ra}$ (–)	$\nu_{ra}$ (–)	$\nu_{ra}$ (–)	
<i>R</i>	<i>llt</i>	6/20	8.7/8.7	747/735	–	0.09	0.65	18.9/5.1
		6/20	12.7/12.9	731/718	–	0.07	0.64	44.4/6.3
		9/20	15.9/16.4	724/727	–	0.06	0.64	59.7/3.9
		8/20	18.5/18.6	717/720	–	0.05	0.63	42.3/2.8
<i>L</i>	<i>rlt</i>	21/21	8.7/8.7	700/700	0.31	–	0.26	26.0/25.5
		20/20	12.3/12.3	731/731	0.27	–	0.24	23.9/26.3
		20/19	15.9/15.8	711/710	0.24	–	0.18	26.8/31.2
		19/15	17.9/17.9	690/683	0.24	–	0.18	35.1/44.9
<i>T</i>	<i>rl</i>	21/9	8.7/8.7	622/618	0.29	0.10	–	16.3/40.4
		24/10	12.1/12.2	621/615	0.27	0.09	–	20.3/38.1
		21/10	16.3/15.6	626/626	0.27	0.06	–	9.4/49.4
		21/10	17.4/17.2	623/619	0.28	0.06	–	8.3/35.7

<sup>a</sup> Replacement character**Table 4** Moisture-dependent Poisson's ratios of European beech; comparison of mean values at 12.5% moisture content and literature references

References	Density $\rho$ (kg/m <sup>3</sup> )	Moisture content $\omega$ (%)	Poisson's ratios (–)					
			$\nu_{lr}$	$\nu_{rl}$	$\nu_{rt}$	$\nu_{rt}$	$\nu_{lr}$	$\nu_{lr}$
Measurements of this study	691	12.5	0.64	0.24	0.27	0.27	0.07	0.09
Stamer and Sieglers Schmidt (1933)	745	10.5	0.75	0.51	0.45	0.36	0.07	0.04
Wommelsdorf (1966)	–	8.2	0.65	0.48	0.37	0.33	0.06	0.03
Neumann (1998)	–	12	0.77	–	–	0.29	–	–
Grimmel (1999)	720	–	0.68	–	–	0.25	–	–
Bodig and Jayne (1993) (hardwood)	–	12	0.67	0.50	0.37	0.33	0.04	0.03

can obviously be confirmed by the comparison of the resulting linear functions. The maximum deviations of the ultrasound velocities summarised over all moisture states differ from 4.1% in the *LT/TL* plane over 12.5% in the *LR/RL* plane and up to 12.7% in the *RT/TR*. These low deviations compared with the variances of the individual test series legitimate a simple averaging procedure on the appropriate data sets. Table 5 summarises the obtained moisture-dependent shear properties. Besides very low CoV for the density and the moisture content, significant moisture dependence is clearly visible. In the tested moisture range, a decrease in the shear moduli varying from  $\approx 15\text{--}40\%$  can be observed. Apparently, a ratio of approximately 3(*LR*):2(*LT*):1(*RT*) between the material planes is valid for the shear moduli.

Literature references (Table 6) for the shear moduli of European beech are rare and moisture-dependent values almost unavailable. A comparison of the existent

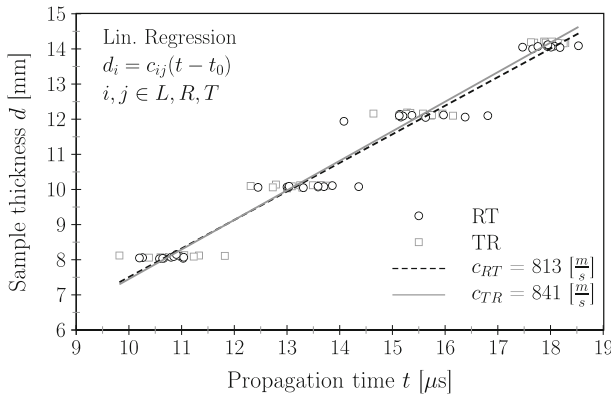

**Fig. 2** Propagation velocity analysis by means of linear regression with multiple sample thicknesses. (Scheme with both measurement options in *RT* plane for a moisture content of  $\omega = 11.9\%$ )

**Table 5** Moisture-dependent shear moduli of European beech determined with ultrasonic waves

<i>n</i> = 40	Moisture content $\omega$ (%)	Density $\rho$ (kg/m <sup>3</sup> )	<i>LR/RL</i>		<i>LT/TL</i>		<i>RT/TR</i>	
			<i>G</i> (MPa)	<i>r</i> <sup>2</sup> (–)	<i>G</i> (MPa)	<i>r</i> <sup>2</sup> (–)	<i>G</i> (MPa)	<i>r</i> <sup>2</sup> (–)
$\bar{x}$	8.2	709	1,360	0.99	973	0.98	550	0.98
CoV (%)	9.2	4.2						
$\bar{x}$	11.9	711	1,280	0.98	855	0.97	486	0.97
CoV (%)	13.8	4.6						
$\bar{x}$	15.8	709	1,280	0.98	833	0.97	406	0.95
CoV (%)	2.6	4.1						
$\bar{x}$	18.7	708	1,180	0.98	771	0.96	400	0.95
CoV (%)	3.0	4.2						

$\bar{x}$  mean value, *CoV* coefficient of variation, *r*<sup>2</sup> coefficient of correlation

**Table 6** Moisture-dependent shear moduli of European beech; comparison of mean values at 11.9% moisture content and literature references

References	Density $\rho$ (kg/m <sup>3</sup> )	Moisture content $\omega$ (%)	Shear moduli (MPa)		
			<i>G</i> <sub>LR/RL</sub>	<i>G</i> <sub>LT/TL</sub>	<i>G</i> <sub>RT/TR</sub>
Measurements of this study (Ultrasound 1 MHz)	711	11.9	1,280	860	490
Bucur and Archer (1984) (Ultrasound 0.5 MHz)	674	–	1,240	860	350
Bucur and Archer (1984) (Ultrasound 1 MHz)	674	–	1,400	980	360
Neumann (1998) (Shear frame)	–	12	750	720	–
	–	18	630	600	–
Neumann (1998) (Torsion, static)	–	12	1,110	770	220
Hearmon and Barkas (1941) (Torsional vibration)	750	12	980	760	370
Stamer and Sieglerschmidt (1933) (Torsion, static)	750	12	1,250	700	620



references given for a moisture content of  $\omega \approx 12\%$  with the authors' own measurements reveals a reasonable similarity. However, the exact specification of the wooden material used by Bucur and Archer (1984) and Hearmon and Barkas (1941) remains unclear, and the values of Stamer and Sieglerschmidt (1933) have poor statistical significance.

Three-dimensional elasticity

To characterise the elastic properties of a wooden material, the engineering parameters, Young's moduli, shear moduli and Poisson's ratios are usually represented as components of a  $6 \times 6$  compliance matrix  $\mathbf{S}$ , which can be given by:

$$\mathbf{S} = \begin{bmatrix} E_L^{-1} & -\nu_{LR}E_R^{-1} & -\nu_{LT}E_T^{-1} & 0 & 0 & 0 \\ -\nu_{RL}E_L^{-1} & E_R^{-1} & -\nu_{RT}E_T^{-1} & 0 & 0 & 0 \\ -\nu_{TL}E_L^{-1} & -\nu_{TR}E_R^{-1} & E_T^{-1} & 0 & 0 & 0 \\ 0 & 0 & 0 & G_{LR}^{-1} & 0 & 0 \\ 0 & 0 & 0 & 0 & G_{LT}^{-1} & 0 \\ 0 & 0 & 0 & 0 & 0 & G_{RT}^{-1} \end{bmatrix} \tag{4}$$

Using the data from Tables 1, 3, 5 and Eq. 4, every orthotropic compliance component  $s_{ij}$  can be derived. Table 7 gives an overview of the determined moisture-dependent compliance parameters. For a general classification into four moisture levels, the resulting differences in the moisture values caused by varying measurement procedures were averaged. The diagonal elements clearly show an increase in compliance with increasing moisture content. These elements show very similar relative moisture sensitivity, even though considerable differences in the parameters' absolute values exist. However, the non-diagonal elements (except for the connection between the  $R$  and  $T$  direction) indicate no analogous significant

**Table 7** Moisture-dependent compliance parameters of European beech wood

	Compliance parameters ( $\times 10^{-12} \text{ Pa}^{-1}$ )			
	$\omega = 8.6\%$	$\omega = 12.3\%$	$\omega = 16.1\%$	$\omega = 18.2\%$
$s_{11}$	69	72	76	86
$s_{22}$	502	527	637	701
$s_{33}$	1,470	1,650	1,980	2,110
$s_{44}$	736	779	783	850
$s_{55}$	1,030	1,170	1,200	1,300
$s_{66}$	1,820	2,060	2,460	2,500
$-\nu_{12}$	47	35	40	33
$-\nu_{13}$	149	147	127	131
$-\nu_{23}$	433	439	543	598
$-\nu_{21}$	22	19	18	20
$-\nu_{31}$	18	17	14	16
$-\nu_{32}$	324	335	405	442

behaviour. Moreover, the difference between the corresponding non-diagonal elements attracts attention. Usually, they are assumed to be equal, even though Neuhaus (1983) or Bodig and Jayne (1993) mentioned partial variations of this material symmetry. When comparing the appropriate non-diagonal compliance parameters in Table 7, deviations of approximately 35% for the coupling of the  $R$  and  $T$  directions can be noticed, which is comparable to literature references (Bodig and Jayne 1993; Keunecke et al. 2008). Values related to the  $LR$  plane, however, are more than twice as high, and the components in the  $LT$  plane are partially almost decoupled. Besides low absolute values resulting in an expanded uncertainty measurement, only strains at the specimen surface were taken into account.

Nevertheless, it has to be kept in mind that the symmetry of the compliance matrix is an approach to reduce the unknown coefficients for the material description, which works very well for many wood species but is still a simplification. For a better understanding of the complex material behaviour, the elastic properties can be described by means of ‘deformation bodies’, which illustrate the degree of deformation of a material depending on the load direction (Grimsel 1999; Keunecke et al. 2008). To simplify matters, the following illustrations were generated assuming the discussed material symmetry by averaging the non-diagonal compliance elements. To demonstrate the moisture dependency of the compliance, a two-dimensional illustration in the principle planes is provided in Fig. 3a. An increase in compliance with increasing moisture content can be observed in all planes. The connection between the absolute compliance value and the moisture sensitivity is clearly visible. Furthermore, this illustration gives an impression of an off-axis deformation. Moreover, the moisture dependency is spatially illustrated in Fig. 3b by comparing the three-dimensional deformation bodies. In this manner, the influence of the moisture content on the overall

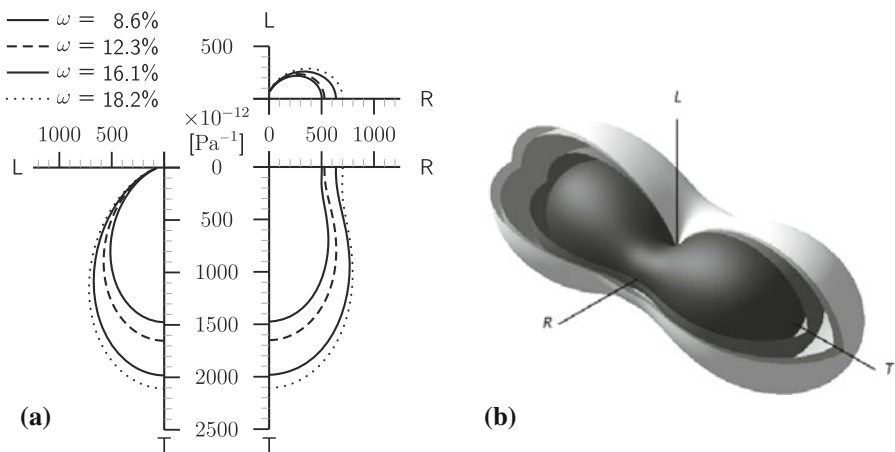

**Fig. 3** Load-directional dependence of beech wood compliance under compression for different moisture contents illustrated in the principle planes via polar diagrams (a) and in three-dimensional illustration mode (decreasing moisture content from *light* to *dark*) in (b)

deformation capability of European beech under compression can be summarised effectively. Differences of almost 40% for the compliances in the *RT* plane can be distinguished in the three-dimensional representation.

## Conclusion

With compression and ultrasound test methods, the elastic properties of beech wood were quantified at different moisture contents. The results confirm the general influence of the material moisture content and show an increase in compliance with increasing moisture content. However, the impact of moisture on the compliance differs between the components. Compared to the Young's and shear moduli, the Poisson's ratios show a rather low sensitivity to the material's moisture content.

Nevertheless, using this visualisation method for the compliance parameters, a clear moisture dependency on compression ability can be displayed. Moreover, by determining all independent elastic components, not only differences in their moisture sensitivity but also the usually implied symmetry in the non-diagonal elements of the compliance matrix can be found to be an approximation. Even though, by averaging the latter compliance parameters, a usable set of material properties for macroscopic moisture-dependent elastic material modelling of beech wood can be provided.

**Acknowledgments** This work was funded by the State Secretariat for Education and Research of Switzerland (SER) and supported by the European Cooperation in the field of Scientific and Technical Research (COST, Action E53).

## References

- Arcan M, Hashin Z, Voloshin A (1978) A method to produce uniform plane-stress states with applications to fiber-reinforced materials. *Exp Mech* 18(4):141–146
- Bodig J, Jayne BA (1993) *Mechanics of wood and wood composites*. Krieger Publishing Company, New York
- Bucur V (1995) *Acoustics of wood*. CRC Press, Boca Raton
- Bucur V, Archer RR (1984) Elastic constants for wood by an ultrasonic method. *Wood Sci Technol* 18:255–265
- Dahl KB, Malo KA (2009a) Linear shear properties of spruce softwood. *Wood Sci Technol* 43(5–6):499–525
- Dahl KB, Malo KA (2009b) Nonlinear shear properties of spruce softwood: experimental results. *Wood Sci Technol* 69(13):2144–2151
- DIN V 65352 (1987) Verfahren zur statistischen Auswertung der Prüfergebnisse bei der Qualifikations- und Abnahmeprüfung von Faserverbundwerkstoffen. DIN Deutsches Institut für Normung e. V
- Diot S, Guines D, Gavrus A, Ragneau E (2008) Minimization of friction influence on the evaluation of rheological parameters from compression test—application to a forging steel behavior identification. *J Eng Mater T ASME* 131(1):10
- Dumail JF, Oloffson K, Salmén L (2000) An analysis of rolling shear of spruce wood by the Iospescu method. *Holzforschung* 54:420–426
- Garab J, Keunecke D, Hering S, Szalai J, Niemz P (2010) Measurement of standard and off-axis elastic moduli and Poisson's ratios of spruce and yew wood in the transverse plane. *Wood Sci Technol* 44(3):451–464
- Grimsel M (1999) *Mechanisches Verhalten von Holz*. Dissertation, Dresden, p 89

- Guitard D, Amri FE (1987) Tridimensional elastic behavior predicting models for hardwood and softwood (in French). *Ann Sci Forest* 44:335–358
- Hearmon RFS, Barkas WW (1941) The effect of grain direction on the Young's moduli and rigidity moduli of beech and Sitka spruce. In: *Proceedings of the physical society*
- Hörig H (1933) Zur Elastizität des Fichtenholzes. *Z Tech Phys* 12:369–379
- Hörig H (1935) Anwendung der Elastizitätstheorie anisotroper Körper auf Messungen an Holz. *Arch Appl Mech* 6(1):8–14
- Iosipescu N (1967) New accurate procedure for single shear testing of metals. *J Mater* 2:537
- Keunecke D, Sonderegger W, Pereteanu K, Lüthi T, Niemz P (2007) Determination of Young's and shear moduli of common yew and Norway spruce by means of ultrasonic waves. *Wood Sci Technol* 41(4):309–327
- Keunecke D, Hering S, Niemz P (2008) Three-dimensional elastic behaviour of common yew and Norway spruce. *Wood Sci Technol* 42(8):633–647
- Keylwerth R (1951) Die anisotrope Elastizität des Holzes und der Lagenhölzer. Verlag des Vereins Deutscher Ingenieure—VDI-Forschungsheft 430
- Kollmann F (1951) *Technologie des Holzes und der Holzwerkstoffe*. Springer, Berlin
- Neuhaus FH (1981) Elastizitätszahlen von Fichtenholz in Abhängigkeit von der Holzfeuchtigkeit. Dissertation, Bochum, p 162
- Neuhaus FH (1983) Über das elastische Verhalten von Fichtenholz in Abhängigkeit von der Holzfeuchtigkeit. *Holz Roh Werkst* 41:21–25
- Neumann AJ (1998) Ermittlung und Bewertung der elastischen Materialkennwerte von Vollholz in Abhängigkeit der Feuchte und der Anisotropie. Master Thesis, Dresden, p 87
- Niemz P (1993) *Physik des Holzes und der Holzwerkstoffe*. DRW-Verlag Weinbrenner GmbH & Co
- Niemz P, Caduff D (2008) Research into determination of the Poisson ratio of spruce wood. *Holz Roh Werkst* 66(1):1–4
- Pozgaj A, Chovanec D, Kuriatko S, Babiak M (1993) Štruktúra a vlastnosti dreva (Wood structure and properties). *Príroda*, Bratislava
- Stamer J (1935) Elastizitätsuntersuchungen an Hölzern. *Arch Appl Mech* 6(1):1–8
- Stamer J, Sieglerschmidt H (1933) Elastische Formänderung der Hölzer. *Zeitschrift des Vereins Deutscher Ingenieure* 77(19):503–505
- van Mier JGM (1997) *Fracture processes of concrete: assessment of material parameters for fracture models*. CRC Press, Boca Raton
- Wommelsdorf O (1966) Dehnungs- und Querdehnungszahlen von Hölzern. Dissertation, Hannover, p 100