

REVIEW ARTICLE

INTERNATIONAL MICROBIOLOGY (2004) 7:95–104
www.im.microbios.org

INTERNATIONAL
MICROBIOLOGY

M. Mar Jiménez-Gasco¹
Juan A. Navas-Cortés²
Rafael M. Jiménez-Díaz^{2,3*}

¹Department of Plant Pathology,
The Pennsylvania State University,
University Park, PA, USA

²Department of Crop Protection,
Institute for Sustainable
Agriculture, CSIC, Córdoba, Spain

³College of Agronomy and Forestry,
University of Córdoba, Spain

The *Fusarium oxysporum* f. sp. *ciceris*/Cicer arietinum pathosystem: a case study of the evolution of plant-pathogenic fungi into races and pathotypes

Summary. The use of resistant cultivars is one of the most practical and cost-efficient strategies for managing plant diseases. However, the efficiency of resistant cultivars in disease management is limited by pathogenic variability in pathogen populations. Knowledge of the evolutionary history and potential of the pathogen population may help to optimize the management of disease-resistance genes, irrespective of the breeding strategy used for their development. In this review, we examine the diversity in virulence phenotypes of *Fusarium oxysporum* f. sp. *ciceris*, the causal agent of Fusarium wilt of chickpeas, analyze the genetic variability existing within and among those phenotypes, and infer a phylogenetic relationship among the eight known pathogenic races of this fungus. The inferred intraspecific phylogeny shows that each of those races forms a monophyletic lineage. Moreover, virulence of races to resistant chickpea cultivars has been acquired in a simple stepwise pattern, with few parallel gains or losses. Although chickpea cultivars resistant to Fusarium wilt are available, they have not yet been extensively deployed, so that the stepwise acquisition of virulence is still clearly evident. [Int Microbiol 2004; 7(2):95–104]

Key words: *Cicer arietinum* · Fusarium wilt · pathogenic variability · DNA fingerprinting · gene genealogy · transposons

Received 4 December 2003

Accepted 30 January 2004

*Corresponding author:

Rafael M. Jiménez-Díaz

Departamento de Protección de Cultivos

Instituto de Agricultura Sostenible, CSIC

Apartado 4084

14080 Córdoba, Spain

Tel. +34-957499221. Fax +34-957499252

E-mail: agljdir@uco.es

Introduction

Plant diseases continue to threaten crop production in modern agriculture, thus challenging plant pathologists for their efficient management. A recent study indicates an average 12.4% loss of attainable harvest for eight crops of significance for food and industry, which together account for more than half of the cultivated area in the world (i.e. barley, cotton, coffee, maize, potato, rice, soybean and wheat) [30]. The monetary value of that loss amounts to 13% of the potential harvest value, to which not less than 10% post-harvest loss should be added.

The use of resistant cultivars is one of the most practical and cost-efficient strategies for plant disease management. Possibly, this control strategy will become increasingly widespread in the coming years in order to satisfy consumers' demand for healthier foods and better environmental quality through new forms of agricultural production, i.e. sustainable agriculture, organic agriculture, and ecological agriculture. However, the efficiency of resistant cultivars in disease management can be seriously limited by pathogenic variability occurring in pathogen populations, including the existence of pathogenic races (defined as biotypes of a pathogen able to cause disease on host cultivars carrying specific resistance genes) and pathotypes (defined as biotypes of a pathogen

able to cause a particular disease syndrome in the host plant).

For almost 100 years, since the discovery of pathogenic races in plant pathogens and 'major gene'-regulated complete disease resistance in plants (defined as the ability to prevent the establishment of infection), plant pathologists have witnessed the breakdown of valuable disease resistance as a result of adaptations in the pathogen population to the presence of major disease-resistance genes (R). The most dramatic and best documented examples of resistance breakdown concern biotrophic pathogens, in which there is a gene-for-gene interaction [6] between virulence in the pathogen (defined as the ability to cause disease on plants with race-specific resistance) and resistance in the host (e.g. downy mildews, powdery mildews, rusts). In this interaction, avirulence genes in the pathogen show a functional correspondence with their matching genes in the host so that molecules encoded by avirulence genes are recognized directly or indirectly by the matching R gene product.

The breakdown in resistance was a consequence of directional selection for better-adapted mutants, recombinants, or immigrants, posed by the widespread and intense deployment of R genes favored by monoculture-type practices and genetic uniformity that prevails in modern agriculture [2]. The vulnerability of major-gene resistance has emphasized the advantages of partial, quantitatively inherited resistance based on the efficient expression of plant defense mechanisms against pathogens (i.e. phytoalexins, pathogenesis-related proteins, hydrolytic enzymes, phenolic compounds, cell wall reinforcement, etc.) that do not follow (or the it is difficult to demonstrate) the gene-for-gene relationship. Quantitative resistance tends to be effective against all pathogen variants. However, there have been examples in this type of resistance of an 'erosion' in efficiency rather than a breakdown, as a result of evolution in pathogen populations [5,18]. Therefore, knowledge of the evolutionary history and potential of the pathogen population may help to optimize the management of disease-resistance genes, irrespective of the breeding strategy used for their development, i.e. conventional plant breeding or genetic engineering [27]. In this review, we examine the genetic variability existing within and among pathogenic races in a fungal plant pathogen, and infer a phylogenetic relationship among them, using *Fusarium oxysporum* f. sp. *ciceris*/chickpea (*Cicer arietinum*) as a model pathosystem for the analysis.

Virulence phenotypes in *Fusarium oxysporum* f. sp. *ciceris*

Fusarium oxysporum f. sp. *ciceris* is a soil-borne fungus pathogenically specialized on *Cicer* spp. [19] that causes

Fusarium wilt in chickpea, the only cultivated species of *Cicer*. This disease, which is one of the most important factors limiting chickpea production worldwide [11], has been the target of breeding for resistance [13,24,33]. Resistant cultivars are one of the few means for managing Fusarium wilt of chickpeas, but their deployment has not been extensive because of undesirable agronomic characteristics. However, the high pathogenic variability in *F. oxysporum* f. sp. *ciceris* may limit the effectiveness of resistance [9,13]. Two pathotypes have been distinguished within *F. oxysporum* f. sp. *ciceris* based on the distinct yellowing or wilting syndromes they cause in chickpeas [36]. The yellowing pathotype induces progressive foliar yellowing with vascular discoloration, while the wilting one induces severe and fast chlorosis, flaccidity and vascular discoloration.

In addition to major symptom types, eight pathogenic races (races 0, 1A, 1B/C, 2, 3, 4, 5 and 6) can be identified in *F. oxysporum* f. sp. *ciceris* based on disease reactions on a set of differential chickpea cultivars [9,13]. Races 0 and 1B/C induce the yellowing symptoms (yellowing pathotype), whereas the remaining races cause wilting (wilting pathotype) [3,15,20]. The eight races also have a distinct geographic distribution. Races 2, 3 and 4 have only been reported in India [9], whereas races 0, 1B/C, 5 and 6 are found mainly in the Mediterranean region and the United States (California) [8,13,15]. Unlike the other races, race 1A is more widespread and has been reported in India, California, and the Mediterranean region [9,15].

Besides the differences in virulence phenotype, pathogenic races of *F. oxysporum* f. sp. *ciceris* differ also in aggressiveness (defined as the amount of disease caused by a pathogen genotype on a given genotype of the host plant), as indicated by differences in the amount of inoculum needed to cause severe disease in a chickpea cultivar. At 25°C, the optimum temperature for Fusarium wilt development, the maximum amount of disease in 'P-2245' chickpea was attained despite a very low initial inoculum density (i.e. 6–50 chlamydo-spores/g soil) of the wilt-inducing race 5 (Fig. 1A) [28]. Conversely, an inoculum density of 20,000 chlamydo-spores/g soil of the yellowing-inducing race 0 was required to cause similar amount of disease in that same cultivar (Fig. 1B) [28]. Also, when the aggressiveness of race 1B/C (yellowing pathotype) was compared with that of races 1A and 5 (wilting races) on race 0-resistant 'PV-61' chickpea, maximum intensity of disease occurred with an inoculum density of 1000 chlamydo-spores/g soil of race 5, which was not significantly different from that reached with 5000 chlamydo-spores/g soil. However, 5000 chlamydo-spores/g soil of race 1A were required for the same intensity of disease to develop, and the maximum intensity of disease attained

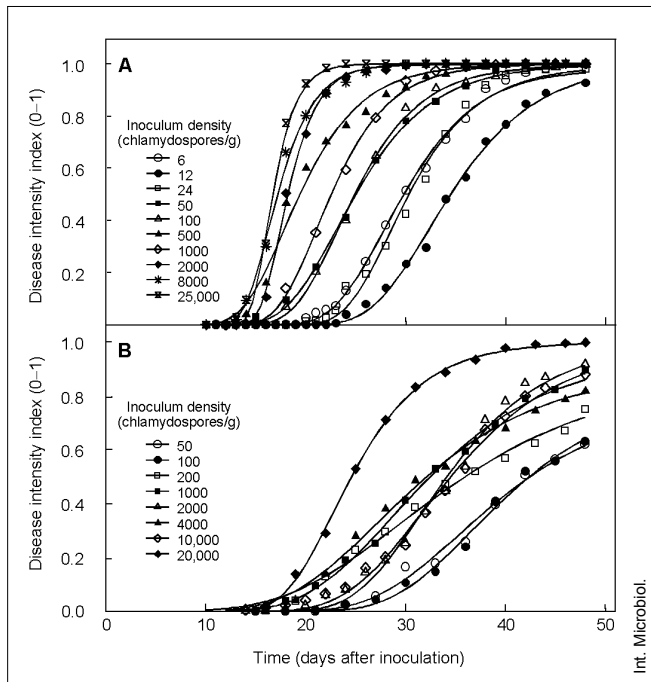

Fig. 1. *Fusarium* wilt disease progress in chickpea cultivar P-2245 grown in soil infested with different inoculum densities of *Fusarium oxysporum* f. sp. *ciceris* races 5 (A) and 0 (B). Each point is the mean disease intensity index calculated with data from four randomized blocks, each with three pots and four plants per pot at 2-day intervals. The solid line represents the predicted disease progress curve calculated by the Gompertz function.

with 5000 chlamydo-spores/g soil of race 1B/C was similar to that attained with 1000 chlamydo-spores/g soil of race 1A (Fig. 2).

Note that races 0 and 1B/C share symptom type but differ in virulence to just one of the 10 race-differential cultivars used in this study, whereas races 1B/C and 1A differ in symptom type as well as in partial or full virulence, respectively, to race-differential cv. C-104 (Table 1). Therefore, it appears that, as a whole, the yellowing *F. oxysporum* f. sp. *ciceris* pathotype is less aggressive than the wilting pathotype, but differences in aggressiveness to chickpea cultivars can also occur among races within a pathotype. Differences in the stages of plant-pathogen interaction might account for the difference in aggressiveness between *F. oxysporum* f. sp. *ciceris* races observed in our studies. One of these would be, for example, the faster and more extensive colonization of xylem vessels in ‘P-2245’ chickpea roots and stem by race 5 than by race 0, as revealed in histological studies [12].

Evolutionary pattern in *Fusarium oxysporum* f. sp. *ciceris*

Fusarium oxysporum is a cosmopolitan soil-borne species complex composed of pathogenically specialized *formae*

speciales and nonpathogenic root-inhabiting parasitic populations, for which no sexual means of reproduction is yet known. The forced asexual reproduction in *F. oxysporum* precludes regular recombination, and genetic variation must result mainly from the accumulation of mutations. As a consequence, in these fungi the whole genome is linked, transmitted as a unit from one generation to the next, and their natural populations should be clonal in nature.

Clonality in *F. oxysporum* has been associated with vegetative compatibility [7,21], i.e. the ability of fungal isolates to establish stable heterokaryons by continued anastomosis between adjacent homokaryotic hyphae [4,7,23]. Compatible isolates belong to the same vegetative compatibility group (VCG) and are in effect genetically isolated from isolates in other VCGs within the species by incompatibility mechanisms. In ascomycetes, to which teleomorphic stages of *Fusarium* belong, vegetative compatibility is homogenic in a set of incompatibility loci (designated *vic* or *v-c*), so that strains in the same VCG carry the same alleles at all *vic* loci [23]. Results of studies in VCG diversity and molecular genetics in *F. oxysporum* indicate that VCGs and molecular markers are usually not independently associated, which has been interpreted to mean that VCGs in *F. oxysporum* represent clones or lineages [23]. Furthermore, studies also indicate that the *formae speciales* in pathogenic *F. oxysporum* may have different evolutionary patterns. Thus, some *formae speciales* (i.e. *albedinis*, *canariensis*, *conglutinans*) must have originated once and are therefore monophyletic [1,22], whereas others (i.e. *cubense*, *lycopersici*, *melonis*) must have originated multiple and independent times and are therefore polyphyletic [1,29].

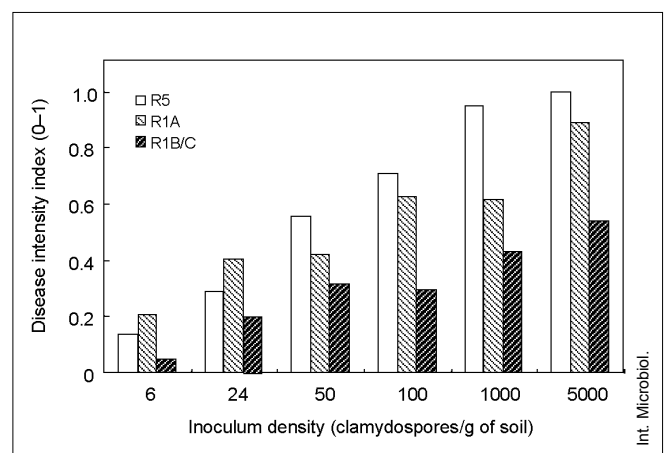

Fig. 2. *Fusarium* wilt disease intensity in chickpea cultivar PV-61 grown in soil infested with different inoculum densities of *Fusarium oxysporum* f. sp. *ciceris* races 1A, 1B/C and 5. Each bar is the mean disease intensity index calculated with data from four randomized blocks, each with three pots and four plants per pot at the end of the experiment 48 days after inoculation.

Table 1. Disease reaction of differential chickpea lines to inoculation with pathogenic races of *Fusarium oxysporum* f. sp. *ciceris*^a

Differential chickpea line	Code ^b	Pathogenic race							
		0	1A	1B/C	2	3	4	5	6
12-071/10054	A	S	M	S	R	R	R	R	M
JG-62	B	R	S	S	S	S	S	S	S
C-104	C	M	M	R/M	S	S	S	S	M
JG-74	D	R	R	R	S	R	R	M	R
CPS-1	E	R	R	R	S	M	M	M	R
BG-212	F	R	R	R	S	M	M	R	R
WR-315	G	R	R	R	R	S	R	R	R
ICCV-2	H	R	R	R	S	S	S	S	M
ICCV-4	I	R	R	R	S	S	S	S	M
P-2245	J	S	S	S	S	S	S	S	S

^aDisease was evaluated on a 0–4 severity scale depending on the percentage of affected foliar tissue (0 = 0%, 1 = 1–33%, 2 = 34–66%, 3 = 67–100%, 4 = dead plant) at 40 days after sowing in an infested soil [9,13]. Average disease reactions of <1 and >3 were considered resistant (R) and susceptible (S), respectively. Intermediate disease reactions were considered moderately susceptible (M) [9,13].

^bCode used to map each differential cultivar onto the neighbor-joining tree inferred from DNA fingerprints (see Fig. 6).

Whether *F. oxysporum* f. sp. *ciceris* has monophyletic or polyphyletic origin has a direct consequence on the prospects for disease management through genetic resistance. The high phenotypic and geographic diversity observed within the fungus raises the possibility that *F. oxysporum* f. sp. *ciceris* might be polyphyletic. However, despite this high degree of variability, a series of studies showed that all isolates of the pathogen studied—regardless of pathotype, race and geographic origin—are genetically identical for VCG [Nogales-Moncada AM (1997) Ph. D. Thesis, University of Córdoba, Spain], mitochondrial DNA restriction fragment length polymorphism [31], and the sequences of five genes highly conserved in fungi: the translation elongation factor 1 α (EF1 α), β -tubulin, histone 3, actin, and calmodulin [16]. Moreover, when sequences of the EF1 α gene from 17 *F. oxysporum* f. sp. *ciceris* isolates representative of all races, pathotypes and geographic range of the pathogen, and three *F. oxysporum* isolates nonpathogenic to chickpea were compared with 24 EF1 α sequences from isolates of 11 different *formae speciales* of *F. oxysporum* by parsimony analysis, *F. oxysporum* f. sp. *ciceris* isolates formed a clade distinct from other *formae speciales* and nonpathogenic isolates (Fig. 3) [16]. Altogether, the above information indicates that *F. oxysporum* f. sp. *ciceris* has a monophyletic origin.

The simplest interpretation of monophyly and lack of multilocus sequence variation in *F. oxysporum* f. sp. *ciceris* is that the pathogen derives from a small founder population that became pathogenic to *Cicer* spp.; as a consequence, variation in virulence phenotypes must have resulted from the accumulation of relatively recent genetic changes [7]. Based on the monophyly of *F. oxysporum* f. sp. *ciceris*, we hypothesized that such a variation must have arisen after the pathogen diverged from other taxa in the *F. oxysporum*

species complex; and in particular that variation in pathotypes and races on chickpea arose in geographically isolated subpopulations which postdated that divergence [15].

Molecular variability and markers in *Fusarium oxysporum* f. sp. *ciceris*

The few, hypothesized genetic changes in *F. oxysporum* f. sp. *ciceris* are not reflected in the sequences of the genes studied, but they were detected by association with random amplified polymorphic DNA (RAPD) markers. Some 63 [20] and 57 [15] *F. oxysporum* f. sp. *ciceris* isolates, representative of all pathotypes, races and geographic origin of the pathogen, were independently assayed using different sets of three and seven RAPD primers, respectively. UPGMA (unweighted paired group method with arithmetic averages) cluster analyses of both RAPD data sets were consistent in grouping *F. oxysporum* f. sp. *ciceris* isolates into two main clusters that correlated with the yellowing and wilting pathotypes, respectively [15,20]. Results in the two studies were similar and are illustrated in Fig. 4 [15]. Furthermore, the yellowing isolates were divided into two distinct sub-clusters, which corresponded to races 0 and 1B/C. Results from cluster analysis also were consistent with the analysis of molecular variance; genetic differences between isolates of the yellowing and wilting pathotypes were highly significant, as were differences between races 0 and 1B/C [15].

The DNA banding patterns in the RAPD assays allowed the identification of markers that unambiguously differentiate the yellowing and wilting pathotypes [20], as well as pathogenic races 0, 1B/C, 5 and 6 [15]. The reliability of those markers for diagnostic purposes was confirmed by bio-

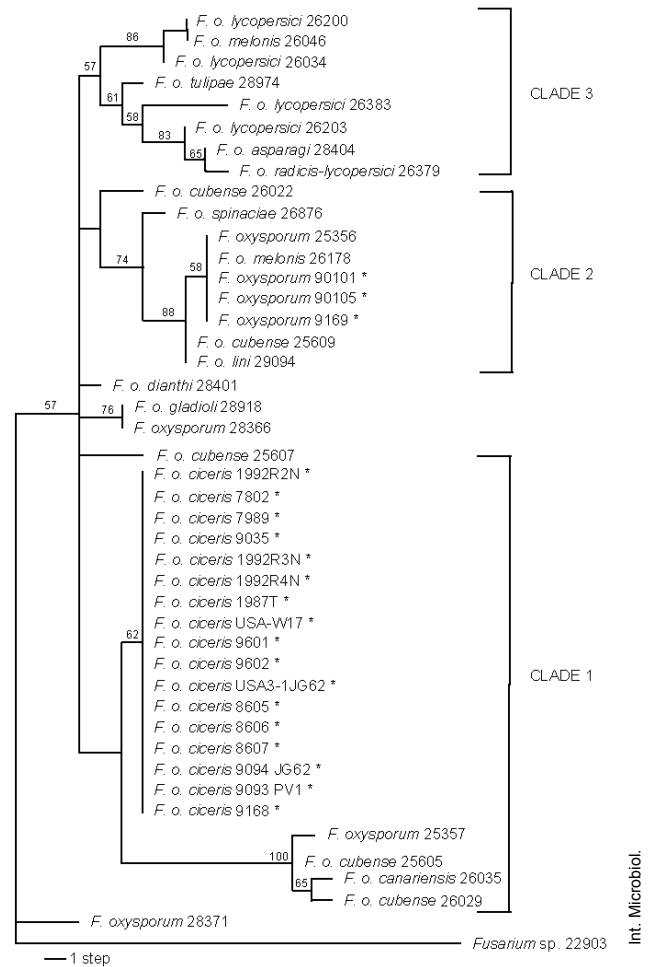

Fig. 3. Genealogy of the translation elongation factor 1 α (EF1 α) gene, demonstrating monophyly in *Fusarium oxysporum* f. sp. *ciceris* [16]. The tree shown is one of the three most-parsimonious trees (73 steps; consistency index, CI = 0.904; retention index, RI = 0.953; rescaled consistency index, RC = 0.862). Sequences from *F. oxysporum* f. sp. *ciceris* and *F. oxysporum* nonpathogenic to chickpea are denoted by * in comparison to sequences from the *Fusarium oxysporum* complex available in GenBank (identified by their NRRL [Agricultural Research Service Culture Collection, National Center for Agricultural Utilization Research, Peoria, IL, USA] isolate number). The tree was rooted with the sequence from *Fusarium* sp. isolate NRRL 22903 [1,29]. Numbers on branches represent bootstrap values >50% based on 1000 replicates.

logical and molecular blind trials and found to be reproducible in repeated experiments [15,20]. Moreover, the race-specific RAPD markers identified were cloned and sequenced, and primers for specific PCR were developed that unambiguously differentiate races 0, 1A, 5, and 6, which are prevalent in the Mediterranean Basin [14].

Genetic variability within and between races of *Fusarium oxysporum* f. sp. *ciceris*

The association between RAPD markers, pathotypes and races in *F. oxysporum* f. sp. *ciceris* allowed the development of diagnostic markers for them; however, RAPDs lack the resolution needed to assess the genetic variability existing within races of the pathogen as well as for inferring an evolutionary relationship among them [15,20]. Nonetheless, discerning the evolutionary pathways for pathogenic variation within *F. oxysporum* f. sp. *ciceris* was possible by means of DNA fingerprinting using three repetitive DNA sequences

from the pathogen genome that share similarities with fungal transposons as probes [14,17]. A total of 36 *F. oxysporum* f. sp. *ciceris* isolates and three nonpathogenic *F. oxysporum* isolates representative of all pathotypes, races and geographic origins of the pathogen were assayed with the three probes, resulting in 88 fragments being scored in the hybridization patterns [17].

Phenetic UPGMA analysis of the combined fingerprinting data clearly delineated pathogenic isolates from nonpathogenic ones, and further divided *F. oxysporum* f. sp. *ciceris* isolates into two distinct clusters highly correlated with the yellowing and wilting pathotypes (data not shown). Furthermore, isolates within each pathotype were distributed in sub-clusters that corresponded to their race. The amount of fingerprinting similarity within races, calculated using Jaccard's coefficient [35] in NYSYSpc2.0 (Exeter Software, Setauket, NY), varied because of differences in sample size and geographic distribution of races. Nonetheless, with samples roughly comparable in size and geographic variation, the most extreme difference was between the average similarities within races 0 and 5, which were approximately 64% and 93%, respectively [17].

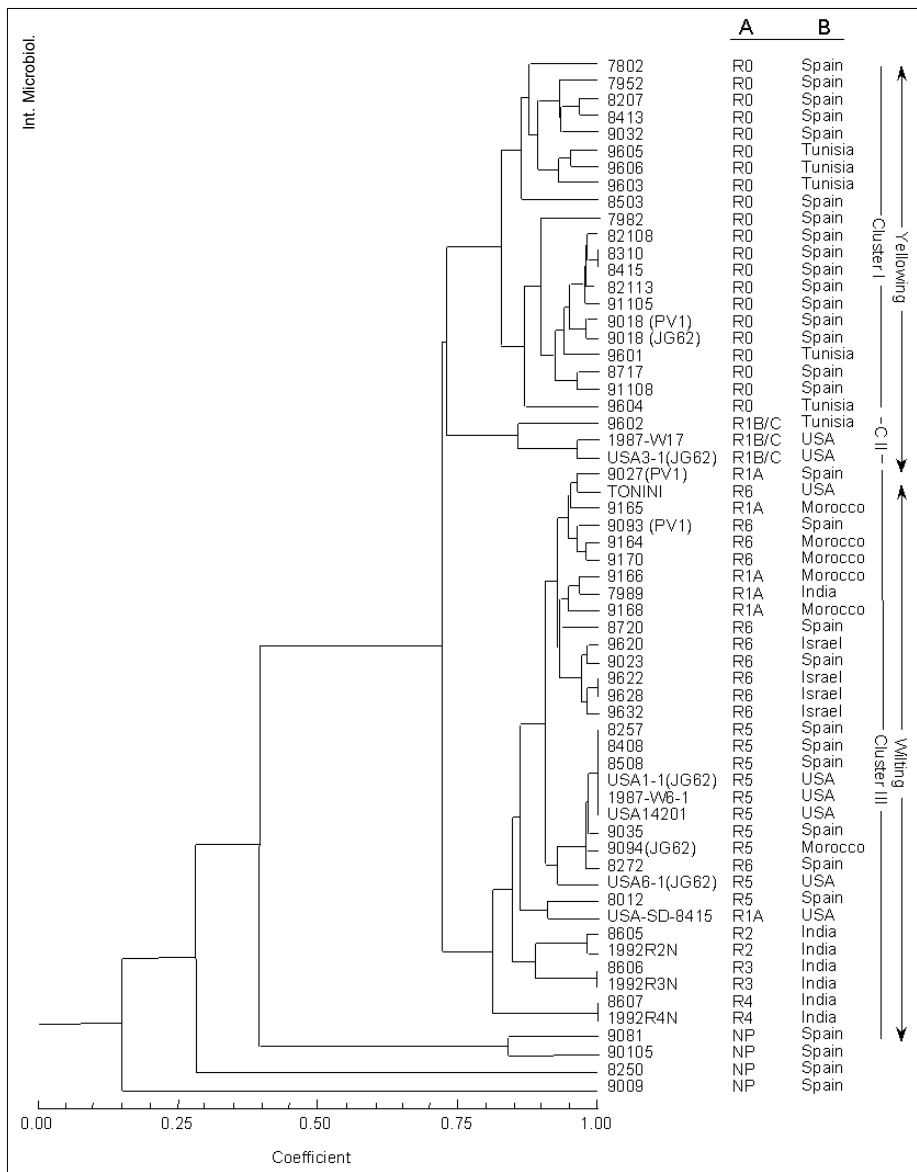

Fig. 4. Dendrogram derived from RAPD analysis of 57 *Fusarium oxysporum* f. sp. *ciceris* isolates and four *F. oxysporum* isolates nonpathogenic to chickpea using primers OPI-01, OPI-09, OPI-18, OPF-06, OPF-10, OPF-12, and OPF-16 [15]. The dendrogram was derived by UPGMA (unweighted paired group method with arithmetic averages). The bottom scale is the percentage of similarity by Jaccard's similarity coefficient. (A) Race assignment of an isolate: R0, race 0; R1A race 1A; R1/BC, race 1B/C; R2, race 2; R3, race 3; R4, race 4; R5, race 5; R6, race 6; NP, nonpathogenic *F. oxysporum*. (B) Geographic origin of isolates.

Inferred phylogeny of *Fusarium oxysporum* f. sp. *ciceris* races based on DNA fingerprints

The phylogeny of *Fusarium oxysporum* f. sp. *ciceris* isolates was inferred from fingerprinting haplotypes in PAUP* 4.0b4a (Sinauer Associated, Sunderland, MA, USA) by neighbor-joining [32] analysis. This cladistic analysis produced trees with branching pattern similar to that obtained with the phenetic UPGMA analysis; pathogenic isolates grouped together in a clade with high bootstrap support and they were clearly delineated from isolates nonpathogenic to chickpea. Within pathogenic isolates, two well-supported clades clearly

correlated with the yellowing and wilting pathotypes, and fingerprint lineages correlated to races, with each race corresponding to a unique lineage with moderate to high bootstrap support for most races (Fig. 5). Neither UPGMA nor neighbor-joining trees showed any association between fingerprint lineage and geographic origin of isolates, except for grouping of races 2, 3, and 4, which have been reported only from India.

Several lines of evidence indicate that the yellowing race 0 is probably ancestral to the wilting races. First, race 0 is virulent on the fewest race-differential cultivars of all pathogen races [13] and is the most widespread race in the Mediterranean region, although it has not been reported in the Indian subcontinent [9,11,13]. Second, *F. oxysporum* f. sp. *ciceris* has a monophyletic origin [16,31], which argues for this pathogen

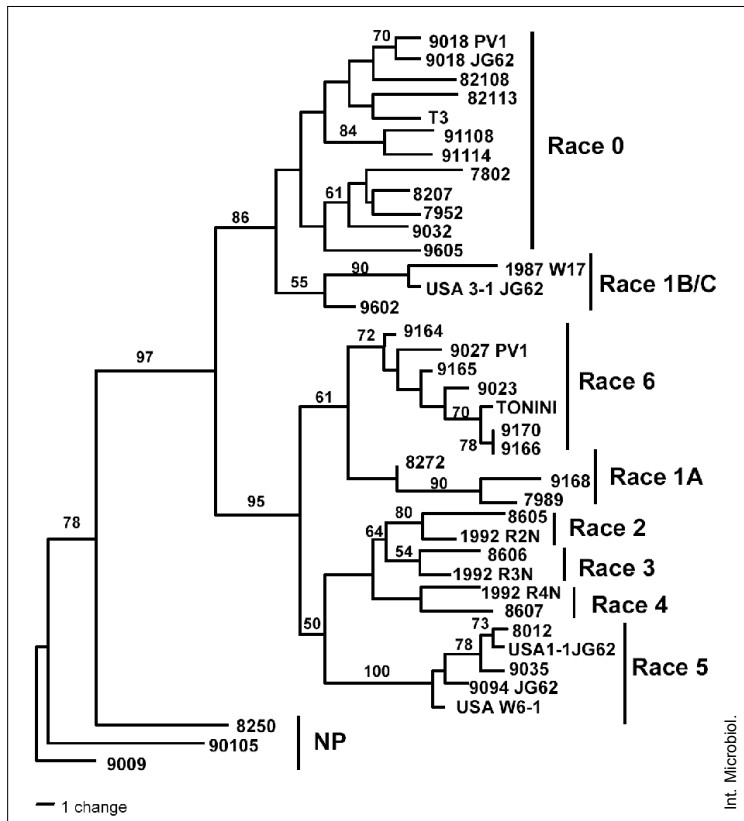

Fig. 5. Inferred phylogeny of races within *Fusarium oxysporum* f. sp. *ciceris* based neighbor-joining analysis of DNA fingerprint haplotypes [17]. Fingerprints were generated by hybridization of genomic DNA to three repetitive probes: FocB10, FocO2 and FocP18. Three *F. oxysporum* isolates (NP) nonpathogenic to chickpea were included for comparison. Numbers on branches represent bootstrap values >50% based on 1000 replicates.

to be derived from parasitic, nonpathogenic populations or from single individuals that acquired pathogenicity on chickpea [3,25]. Therefore, we would expect an ancestral race to be virulent on fewer resistant cultivars than the more recently derived races. Moreover, in this asexually reproducing fungus, genetic variation results mainly from accumulation of mutations over time, which should give rise to greater diversity in older lineages. The relatively low average similarity of fingerprinting [17] and RAPD [15] haplotypes (higher diversity) within race 0 is consistent with the hypothesis of it being an old race. Conversely, race 5 shows the lowest diversity in fingerprinting and RAPD haplotypes and is the most virulent of all races reported in the Mediterranean region [13,15,17]. According to this hypothesis, race 1B/C is the closest to race 0 in evolutionary terms. These two races share the ability to induce the yellowing syndrome in chickpea and show very similar patterns in genetic diversity and virulence [13,15,17].

Stepwise evolution of races in *Fusarium oxysporum* f. sp. *ciceris*

The origin of pathogenic variation has intrigued plant pathologists since the discovery of pathogenic races in the early twentieth century. For asexually reproducing fungal pathogens such as *formae speciales* of *F. oxysporum*, races capable of over-

coming resistance genes are thought to evolve by successive accumulation of mutations. In particular, races with close genetic relatedness in monophyletic *formae speciales* were hypothesized to derive in a stepwise process rather than independently [7]. Although this hypothesis is reasonable, the lack of phylogenetic resolution within monophyletic *formae speciales* of *F. oxysporum* made it difficult to analyze the evolutionary pathways of pathogenic variation. Mapping of virulence to each race-differential chickpea cultivar (see Table 1) onto the inferred phylogeny of clonal lineages (Fig. 6) showed for the first time that races of *F. oxysporum* f. sp. *ciceris* had evolved in a stepwise process [17]. Mapping was done manually to minimize the number of evolutionary events and to infer the two simplest scenarios: (i) considering only the gain, but not the loss of virulence (Fig. 6A); and (ii) allowing virulence to be either gained or lost (Fig. 6B).

The first scenario postulates at least three parallel gains of virulence and the existence of three ancestral races that have never been observed (Fig. 6A), the first acquisition of virulence from the oldest unknown race giving rise to race 0. Thereafter, yellowing race 1B/C evolved from race 0, and wilting races evolved in a stepwise manner from a second ancestral, an unknown race. This scenario is consistent with the phylogeny of races inferred above, with yellowing race 0 being ancestral to wilting races.

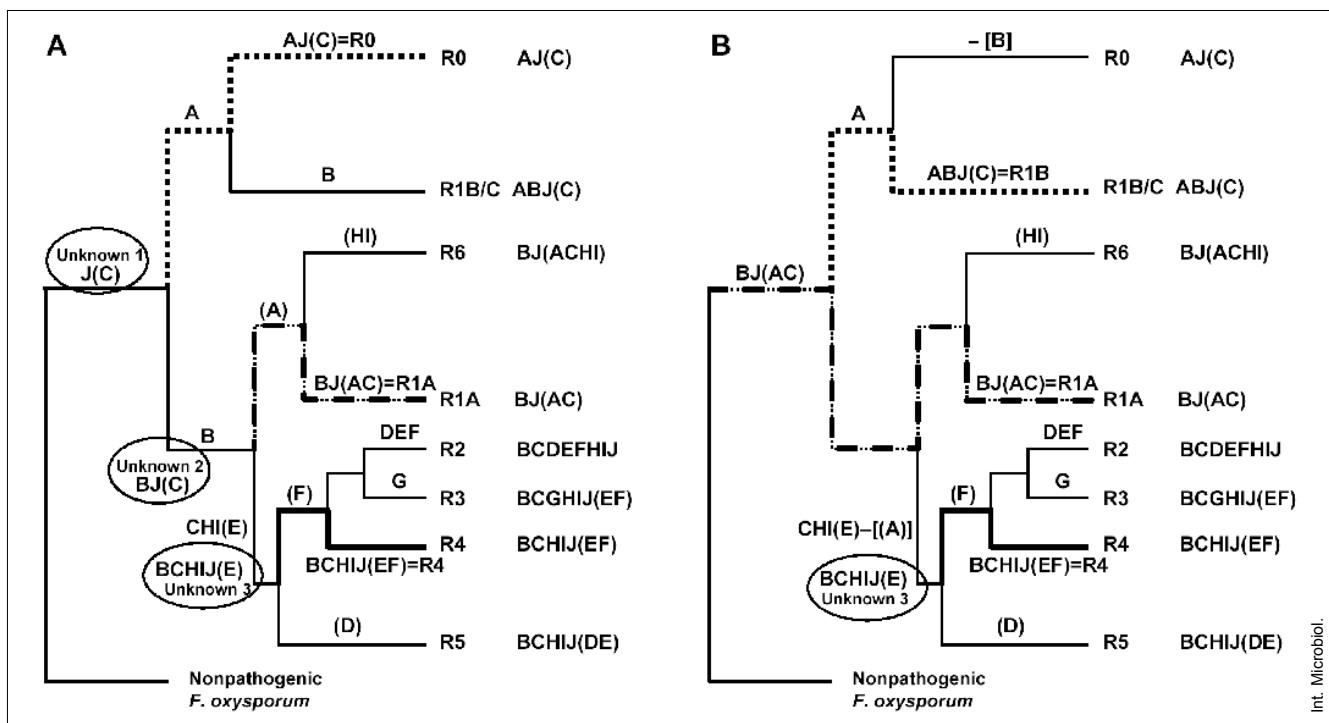

Fig. 6. Mapping of virulence acquisition by races of *Fusarium oxysporum* f. sp. *ciceris* onto the inferred neighbor-joining tree in Fig. 5. Each race is defined by virulence to differential cultivars as shown in Table 1. Capital letters (coded A through J) indicate virulence, and capital letters in parentheses represent partial virulence. Dotted and bold branches indicate the races inferred to be ancestral during the evolution of other races (races 0, 1A and 4 in scenario A; races 1B/C, 1A and 4 in scenario B) (for more details see text and reference [17]). Races that are inferred but have not been found in nature are labeled "unknown". (A) Scenario that allows only the gain, not loss of virulence. (B) Scenario that allows both gains and losses of virulence. Loss of partial virulence to cultivar A is indicated by $-[A]$; loss of virulence to cultivar B is indicated by $-[B]$.

The second scenario inferred in the study [17] seems to be simpler. It suggests that wilting race 1A could be the common ancestor of all races (Fig. 6B), instead of a race that is not known to be extant, as proposed in the first scenario. As expected for an ancient lineage, race 1A is the most widespread geographically; it was first described in India [9] and was later found in the Mediterranean Basin and California [13].

Final remarks

The inferred phylogeny and stepwise evolution of *F. oxysporum* f. sp. *ciceris* provides some insights into long-distance migrations that have occurred for this pathogen. It can be speculated that there were at least two migration events between the Mediterranean region and India, most probably as a consequence of the spread of infected seeds [10]. If *F. oxysporum* f. sp. *ciceris* evolved in the Mediterranean region, then race 1A and the common ancestor of races 2, 3, and 4 must have been introduced into India. Alternatively, if the pathogen evolved in India, then race 1A, which may be the progenitor of all races (Fig. 6B), should have migrated in the opposite direction. In addition, a common ancestor of races

2, 3, 4 and 5 would have migrated from India to the Mediterranean region. In either case, at least two different races have migrated in or out of India. It can be speculated that the Mediterranean region, or the Fertile Crescent, which is the diversity center for *Cicer* spp. [26], is the most probable origin of *F. oxysporum* f. sp. *ciceris*, at some time after the domestication of chickpea, 8000–9000 years ago [26,34]. Regardless of the origin, the similarities in race composition between the Mediterranean region and California indicate that repeated migration has occurred between these two areas rather than the independent evolution of races in different regions.

It is not probable that the stepwise evolution of races in *F. oxysporum* f. sp. *ciceris* resulted from selection by specific resistance in chickpea populations. Some pathogen races are widely distributed geographically even where resistant cultivars have not been deployed. For example, resistant cultivars generally have not been used in the Mediterranean region; this region, however, has a high diversity of races [8,13–15]. Conversely, widespread use of race1A-resistant cultivars H and I in India has not yet led to reports on development of race 6, which specifically overcomes that resistance and derives from race1A (see Table 1)

[13,15]; rather, races 2, 3, and 4, which are virulent to cultivars H and I, were reported in India [9] long before the release of these cultivars [24]. Thus, unlike other pathosystems (e.g. downy mildews, rusts, rice blast), there may have been little or no selection for resistance-breaking races of *F. oxysporum* f. sp. *ciceris*, which minimizes the probabilities of obtaining parallel changes in virulence, such as those frequently observed in other systems. Limited selection by resistance deployment might help to explain why a relatively simple relationship between clonal lineages and virulence acquisition, with few parallel events, can still be detected.

Acknowledgements. Research on Fusarium wilt of chickpeas in RMJD laboratory was supported by grants AGF97-1479 and AGF98-0878 from Comisión Interministerial de Ciencia y Tecnología (CICYT) of Spain.

References

- Baayen RP, O'Donnell K, Bonants PJM, Cigelnik E, Kroon LPNM, Roebroek EJA, Waalwijk C (2000) Gene genealogies and AFLP analyses in the *Fusarium oxysporum* complex identify monophyletic and nonmonophyletic formae speciales causing wilt and rot disease. *Phytopathology* 90:891–900
- Brown JKM (1995) Pathogen's responses to the management of disease resistance genes. In: Andrews JH, Tommerup IC (eds) *Advances in plant pathology*, vol. 11. Academic Press, NY, pp 75–102
- Correll JC (1991) The relationship between formae speciales, races and vegetative compatibility groups in *Fusarium oxysporum*. *Phytopathology* 81:1061–1064
- Di Primo P, Cartia G, Katan T (2001) Vegetative compatibility and heterokaryon stability in *Fusarium oxysporum* f. sp. *radicis-lycopersici* from Italy. *Plant Pathol* 50:371–382
- Flier WG, van den Bosch GBM, Turkensteen, LJ (2003) Stability of partial resistance in potato cultivars exposed to aggressive strains of *Phytophthora infestans*. *Plant Pathol* 52: 326–337
- Flor HH (1971) Current status of the gene-for-gene concept. *Annu Rev Phytopathol* 9:275–296
- Gordon TR, Martyn RD (1997) The evolutionary biology of *Fusarium oxysporum*. *Annu Rev Phytopathol* 35:111–128
- Halila HM, Strange RN (1996) Identification of the causal agent of wilt of chickpea in Tunisia as *Fusarium oxysporum* f. sp. *ciceris* race 0. *Phytopathol Medit* 35:67–74
- Haware MP, Nene YL (1982) Races of *Fusarium oxysporum* f. sp. *ciceris*. *Plant Dis* 66:809–810
- Haware MP, Nene YL, Rajeshwary R (1978) Eradication of *Fusarium oxysporum* f. sp. *ciceris* transmitted in chickpea seed. *Phytopathology* 68:1364–1367
- Jalali BL, Chand H (1992) Chickpea wilt. In: Singh US, Mukhopadhyay AN, Kumar J, Chaube HS (eds) *Plant diseases of international importance*. Vol. 1. Diseases of cereals and pulses. Prentice Hall, Englewood Cliffs, NJ, pp 420–444
- Jiménez-Díaz RM, Basallote-Ureba MJ, Rapoport H (1989) Colonization and pathogenesis in chickpea infected by races of *Fusarium oxysporum* f. sp. *ciceris*. In: Tjamos EC, Beckman CH (eds) *Vascular wilt diseases of plants*. NATO ASI Series Vol. H 28. Springer-Verlag, Berlin, pp 515–520
- Jiménez-Díaz RM, Alcalá-Jiménez AR, Hervás A, Trapero-Casas, JL (1993) Pathogenic variability and hosts resistance in the *Fusarium oxysporum* f. sp. *ciceris* / *Cicer arietinum* pathosystem. In: Proc. 3rd Eur. Semin. *Fusarium* Mycotoxins, Taxonomy, Pathogenicity and Host Resistance. Hodowla Róslin Aklimatyzacja i Nasiennictwo. Plant Breeding and Acclimatization Institute, Radzików, Poland, pp 87–94
- Jiménez-Gasco MM, Jiménez-Díaz RM (2003) Development of a specific polymerase chain reaction-based assay for the identification of *Fusarium oxysporum* f. sp. *ciceris* and its pathogenic races 0, 1A, 5, and 6. *Phytopathology* 93:200–209
- Jiménez-Gasco MM, Pérez-Artés E, Jiménez-Díaz RM (2001) Identification of pathogenic races 0, 1B/C, 5, and 6 of *Fusarium oxysporum* f. sp. *ciceris* with random amplified polymorphic DNA (RAPD). *Eur J Plant Pathol* 107:237–248
- Jiménez-Gasco MM, Milgroom MG, Jiménez-Díaz RM (2002) Gene genealogies support *Fusarium oxysporum* f. sp. *ciceris* as a monophyletic group. *Plant Pathol* 51:72–77
- Jiménez-Gasco MM, Milgroom MG, Jiménez-Díaz RM (2004) Stepwise evolution of races in *Fusarium oxysporum* f. sp. *ciceris* inferred from fingerprinting with repetitive DNA sequences. *Phytopathology* 94:302–307
- Johnson R (1983) Genetic background of durable resistance. In: Lamberti F, Waller JM, van der Graaf NA (eds) *Durable resistance in crops*. NATO ASI Series A., Life Sciences, Plenum Press, NY, pp 5–26
- Kaiser WJ, Alcalá-Jiménez AR, Hervás-Vargas A, Trapero-Casas JL, Jiménez-Díaz RM (1994) Screening of wild *Cicer* species for resistance to races 0 and 5 of *Fusarium oxysporum* f. sp. *ciceris*. *Plant Dis* 78:962–967
- Kelly AG, Alcalá-Jiménez AR, Bainbridge BW, Heale JB, Pérez-Artés E, Jiménez-Díaz RM (1994) Use of genetic fingerprinting and random amplified polymorphic DNA to characterize pathotypes of *Fusarium oxysporum* f. sp. *ciceris* infecting chickpea. *Phytopathology* 84:1293–1298
- Kistler HC (1997) Genetic diversity in the plant-pathogenic fungus *Fusarium oxysporum*. *Phytopathology* 87:474–479
- Kistler HC (2001) Evolution of host specificity in *Fusarium oxysporum*. In: Summerell BA, Leslie JF, Beckhouse D, Bryden WL, Burgess LW (eds) *Fusarium*. Paul E. Nelson Memorial Symposium. APS Press, St Paul, MN, pp 70–82
- Klein KK, Correll JC (2001) Vegetative compatibility group diversity. In: Summerell BA, Leslie JF, Beckhouse D, Bryden WL, Burgess LW (eds) *Fusarium*. Paul E. Nelson Memorial Symposium. APS Press, St Paul, MN, pp 83–96
- Kumar J, Haware MP, Smithson JB (1985) Registration of four short duration Fusarium wilt-resistant kabuli chickpea germplasm. *Crop Sci* 25:576–577
- Leslie JF (1993) Fungal vegetative compatibility. *Annu Rev Phytopathol* 31:127–150
- Lev-Yadun S, Gopher A, Abbo S (2000) The cradle of agriculture. *Science* 288:1602–1603
- McDonald BA, Linde C (2002) Pathogen population genetics, evolutionary potential and durable resistance. *Annu Rev Phytopathol* 40:349–379
- Navas-Cortés JA, Alcalá-Jiménez AR, Hau B, Jiménez-Díaz RM (2000) Influence of inoculum density of races 0 and 5 of *Fusarium oxysporum* f. sp. *ciceris* on development of Fusarium wilt in chickpea cultivars. *Eur J Plant Pathol* 106:135–146
- O'Donnell K, Kistler HC, Cigelnik E, Ploetz RC (1998) Multiple evolutionary origins of the fungus causing Panama disease of banana: concordant evidence from nuclear and mitochondrial gene genealogies. *Proc Natl Acad Sci USA* 95:2044–2049
- Oerke E-C, Weber A, Dehne H-W, Shönbeck F (1994) Conclusions and perspectives. In: Oerke E-C, Dehne H-W, Shönbeck F, Weber A (eds) *Crop production and crop protection*. Elsevier, Amsterdam, pp 742–770
- Pérez-Artés E, Roncero MIG, Jiménez-Díaz RM (1995) Restriction

- fragment length polymorphism analysis of the mitochondrial DNA of *Fusarium oxysporum* f. sp. *ciceris*. J Phytopathol 143:105–109
32. Saitou N, Nei M (1987) The neighbor-joining method: A new method for reconstructing phylogenetic trees. Mol Biol Evol 4:406–425
33. Singh KB (1987) Chickpea breeding. In: Saxena MC, Singh KB (eds) The chickpea. CAB International, Wallingford, Oxon, pp 127–162
34. Singh KB (1997) Chickpea (*Cicer arietinum* L.). Field Crop Res 53:161–170
35. Sneath P, Sokal R (1973) Numerical taxonomy: the principles and practice of numerical classification. W. H. Freeman, San Francisco, CA
36. Trapero-Casas A, Jiménez-Díaz RM (1985) Fungal wilt and root rot diseases of chickpea in southern Spain. Phytopathology 75:1146–1151

El patosistema *Fusarium oxysporum* f. sp. *ciceris*/*Cicer arietinum*: un modelo de la evolución de los hongos patógenos de plantas en razas y patótipos

Resumen. La utilización de cultivares resistentes es una de las estrategias más prácticas y económicas para el control de las enfermedades de las plantas. No obstante, la eficiencia de los cultivares resistentes en dicho control está limitada por la variabilidad patogénica en las poblaciones de los patógenos. El conocimiento de la historia y el potencial evolutivo de las poblaciones de los patógenos puede ayudarnos a optimizar el uso de los genes de resistencia contra enfermedades, independientemente de la estrategia de mejora genética del huésped empleada para su desarrollo. En esta revisión examinamos la diversidad de los fenotipos de virulencia en *Fusarium oxysporum* f. sp. *ciceris*, el agente causal de la Fusariosis vascular del garbanzo, analizamos la variabilidad genética intra- e interfenotípica, e inferimos la relación filogenética existente entre las ocho razas patogénicas conocidas de este hongo. La filogenia intraespecífica inferida muestra que cada una de estas ocho razas constituye un linaje monofilético. Además, las razas virulentas sobre los cultivares resistentes de garbanzo han adquirido esta capacidad según un modelo gradual simple, con pocas ganancias o pérdidas paralelas de virulencia. A pesar de que existen cultivares de garbanzo resistentes a la Fusariosis vascular, la utilización restringida de ellas realizada hasta ahora permite que la adquisición gradual de virulencia sea aún claramente perceptible. [Int Microbiol 2004; 7(2):95–104]

Palabras clave: *Cicer arietinum* · Fusariosis vascular · variabilidad patogénica · impronta genética · genealogía génica · transposones

O patosistema *Fusarium oxysporum* f. sp. *ciceris*/*Cicer arietinum*: um modelo de evolução de fungos fitopatogênicos de plantas em raças e patótipos

Resumo. A utilização de cultivares resistentes é uma das estratégias mais práticas e econômicas para o controle das doenças de plantas. Entretanto, a eficiência dos cultivares resistentes no referido controle está limitada pela variabilidade da patogenicidade nas populações dos patógenos. O conhecimento sobre a história e o potencial evolutivo das populações de patógenos, podem ajudar na otimização do uso dos genes de resistência contra as doenças, independentemente da estratégia empregada para o cultivo do hospedeiro durante seu desenvolvimento. Na presente revisão examinamos a diversidade dos fenótipos de virulência em *Fusarium oxysporum* f. sp. *ciceris*, o agente etiológico da fusariose vascular do feijão garbanzo, analisamos a variabilidade genética intra- e interfenotípica, e inferimos a relação filogenética existente entre as oito raças patogênicas conhecidas deste fungo. A filogenia intraespecífica inferida mostra que as oito raças constituem uma linhagem monofilética. Por outro lado, as raças virulentas sobre os cultivares resistentes de garbanzo adquiriram esta capacidade segundo um modelo gradual simples, com poucos ganhos ou perdas paralelas de virulência. Apesar de existirem cultivares de garbanzo resistentes à fusariose vascular, seu uso fica restrito, de modo que a aquisição gradual de virulência continua evidente. [Int Microbiol 2004; 7(2):95–104]

Palavras chave: *Cicer arietinum* · fusariose vascular · variabilidade patogênica · perfil de DNA · genealogia génica · transposons