

Jürgen Wehland  
Uwe D. Carl

Gesellschaft für Biotechnologische  
Forschung (GBF), Braunschweig, Germany

## The sophisticated survival strategies of the pathogen *Listeria monocytogenes*

Received 10 November 1997  
Accepted 10 January 1998

Correspondence to:  
Jürgen Wehland. Gesellschaft für  
Biotechnologische Forschung.  
Mascheroder Weg 1. D-38124  
Braunschweig, Germany.  
Tel.: +49-531-6181415. Fax: +49-531-  
6181444.  
E-mail: [jwe@gbf.de](mailto:jwe@gbf.de)

**Summary** The function of the ActA protein of *Listeria monocytogenes* has been partially elucidated. These results illustrate the sophistication with which intracellular pathogens like *Listeria* use the host cell to their advantage, and have provided new insights into some of the molecular mechanisms of complex cell functions such as actin-promoted cell motility. The clarification of these processes is of fundamental importance not only for understanding elementary processes such as development and growth, but also for the treatment of both diseases caused by cytopathogenic bacteria such as *Listeria* and pathophysiological processes arising from disorders in cell motility and cell adhesion.

**Key words** *Listeria monocytogenes* · ActA · Profilin · Ena/VASP family · Actin-based motility

### Introduction

Infectious diseases represent one of the greatest dangers to human health worldwide. Even in industrial countries, infections which had long been considered conquered are again on the rise. This phenomenon can be attributed to the increasing occurrence of strains of bacterial pathogens that are resistant to broad spectrums of antibiotics. Thus, effective control of infectious diseases in the future cannot rely solely on the search for new antibiotics, but must also include programs for the development of new vaccines and therapeutic agents. This latter approach requires detailed knowledge of the mechanisms of pathogenesis at the molecular level, taking into consideration both host-pathogen interactions and host defense mechanisms.

During the last decade, new fundamental knowledge has been acquired pertaining to the mechanisms bacterial pathogens use to avoid destruction by their host and exploit its metabolic machinery to their own advantage. This renaissance in research on bacterial pathogenicity was made possible by the combined use of modern techniques in molecular and cell biology, immunology, and microbial genetics. In addition to its importance for the treatment of disease, research on the mechanisms of pathogenesis also reveals detailed insights into the physiology of the host cell, thus contributing significantly to the clarification of complex eucaryotic cell functions.

Bacterial pathogens and their products have therefore become indispensable research tools for many fields such as cell biology and neurobiology. For example, investigations on the toxins secreted by *Bordetella pertussis* (the whooping cough pathogen) and *Vibrio cholerae* (the cholera pathogen) led to the elucidation of the roles of the large heterotrimeric G-proteins in signal transduction. Both of these toxins are ADP-ribosylating enzymes. They modify the  $\alpha$ -subunit of the G-protein which then irreversibly binds to and activates the enzyme adenylate cyclase. In the case of cholera toxin, this leads to an increase in the intracellular cAMP level in intestinal epithelial cells. An increased excretion of sodium ions and water into the intestinal lumen follows, resulting in serious diarrhea. As another example, clarification of the way bacterial neurotoxins work, in particular the tetanus and botulism toxins from clostridia, not only led to a better understanding of neurotransmission processes, but also revealed the basic mechanisms of vesicular protein transport in cells (for references see [20]).

In addition to isolated bacterial products, facultative intracellular bacteria have also attracted increasing attention in cell biology in recent years. The persistence and survival of mycobacteria within their host cells are a result of their ability to prevent acidification of the intracellular vacuoles in which they reside. This has the effect of preventing those cell compartments from maturing and fusing with lysosomes, a process that normally leads to the elimination of the pathogen. Other

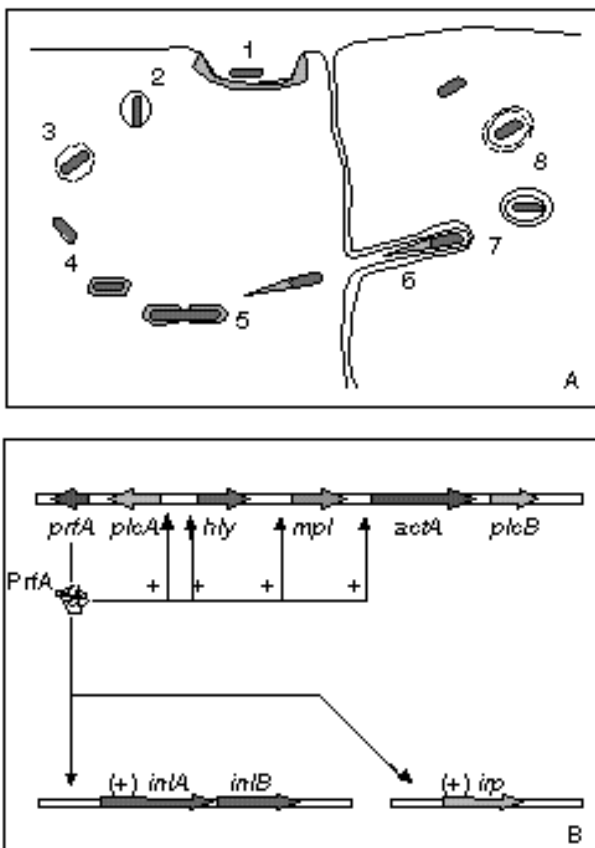

**Fig. 1** (A) The infection of *Listeria monocytogenes* at the cellular level. The numbers in the drawing label each step in the process with respect to the bacterial factors involved according to current understanding (see Fig. 2). 1: adhesion (*inlA*, *inlB*); 2: invasion (*inlA*, *inlB*); 3: release from the phagosome (*hly*, *plcA*); 4: recruitment of actin filaments (*actA*); 5: tail formation and motility (*actA*); 6: development of pseudopodia (?); 7: assimilation of the pseudopodia (?); 8: lysis of the double membrane and release (*plcB*, *hly*). (B) Schematic illustration of the organization of *Listeria monocytogenes* virulence genes and their coordinated regulation by the positive regulation factor PrfA. The virulence gene cluster includes the genes that express the regulatory factor PrfA, a phosphatidylinositol-specific phospholipase (*plcA*), the cytotoxin listeriolysin (*hly*), a metalloprotease (*mpl*), the actin filament accumulating factor (*actA*) and a phosphatidylcholine-specific phospholipase C or lecithinase (*plcB*). The internalin genes (*inlA*, *inlB*) are organized in a separate operon outside of the virulence gene cluster. Recently, an internalin-related protein (*Irp*) was identified that is independent of this operon. Only the expression of the genes in the virulence gene cluster is strictly PrfA-regulated

intracellular bacterial pathogens such as *Shigella* and *Listeria* have developed even more sophisticated mechanisms to insure survival within the infected host cell. These make it possible for them to circumvent the host's defense mechanisms, or immune system (for references see [4, 7]). After being engulfed, or phagocytosed, by the cell, the bacteria secrete hemolytic factors that lyse the surrounding vesicular membrane of the phagosome, allowing them to enter the host cell cytoplasm. In an intriguing series of events, both types

of bacteria begin to accumulate cytoskeletal elements of the host cell, specifically components of the microfilament system, on their surface. These are then transferred to one pole of the bacteria, forming a comet-like tail structure that bestows on these normally immobile bacteria the capability of directional movement within the cytoplasm, an event that has a number of consequences for the host organism (see below).

Two papers, published in 1989, first described these events and provided the basis for the experiments to be discussed in this article. In those publications, Sansonetti and coworkers at the Pasteur Institute in Paris showed that intracellular shigella recruit actin filaments [1], and Tilney and Portnoy from Philadelphia reconstructed the cellular infection cycle of *Listeria* on the basis of elegant electron microscopic analyses [35]. The diagram in Fig. 1A is based on these latter observations. Almost simultaneously, molecular biological methods, including transposon mutagenesis, complementation, and homologous recombination, were developed to the point where it was possible to construct mutants of these intracellular pathogens with defects specifically in the genes to be investigated (Fig. 1B). A close cooperation begun in 1991 with Trinad Chakraborty and focused our work on listeria, and in particular on *Listeria monocytogenes*, because this pathogen has several advantages over shigella. *L. monocytogenes* is a pathogen for both humans and animals, and therefore has a broad host spectrum in contrast to shigella, which is strictly a human pathogen. This allows the use of a variety of tissue culture cells for in vitro analyses of the behavior of the pathogen at the individual host cell level. In addition, the mouse is an ideal animal model for in vivo investigations, in which *L. monocytogenes* infection has long been used for the study of T-cell mediated immunity [13].

## The infection cycle of *Listeria*

*Listeria* are ubiquitously occurring, Gram-positive, non-sporulating rod-shaped bacteria. The genus *Listeria* comprises six species of which two are pathogenic. *Listeria ivanovii*, unlike *L. monocytogenes*, is pathogenic only for animals. Listeriosis, the illness caused by *L. monocytogenes*, is characterized in its acute phases by meningoencephalitis, meningitis, and septicemia, and it can cause damage to the unborn. The infection is usually disseminated through contaminated food, in particular dairy products made from unpasteurized milk such as some cheeses, but also from meat products such as pâtés. The pathogen enters the host organism via the intestinal epithelium. Despite frequent exposure within the general population, serious complications rarely

develop. However, people with weakened immune systems are particularly at risk, and the pathogen can be transferred to the fetus during pregnancy. Pathogenic listeriae are a problem for food storage and conservation because of their special ability to multiply even under high salt concentrations and at low temperatures [12, 29].

The infection cycle of *L. monocytogenes*, shown in Fig. 1A, is remarkable for several reasons. In addition to being ingested by professional phagocytes such as macrophages, listeria can also infect non-phagocytic cells such as epithelial and connective tissue cells. The bacteria have developed mechanisms to induce their own phagocytosis, thus gaining entrance into the host cell. This is brought about by the listerial internalin proteins (InlA and InlB), to which adhesion as well as invasion activities has been attributed [10, 17]. The amino-terminal regions of both internalin A and internalin B contain leucine-rich repeats with lengths of 22 amino acids. They can therefore be assigned to a protein superfamily all of which contain leucine-rich repeats and whose members occur in eucaryotic cells and procaryotic pathogens. According to current understanding, proteins with these motifs are involved in signal transduction processes [14]. Recently the eucaryotic receptor of Internalin A was identified. InlA interacts directly with the cell-cell adhesion protein E-cadherin [19].

After phagocytosis, bacteria are normally destroyed in special cellular organelles, the phagolysosomes. *L. monocytogenes* avoids this fate by secreting a cytotoxin, listeriolysin. This disrupts the phagosome membrane and allows the pathogen to enter the host cell cytoplasm where it finds suitable conditions for survival. Shortly after its "release" into the cytoplasm, *L. monocytogenes* begins to accumulate actin filaments on its surface. These filaments subsequently organize into a tail-like structure

at one pole of the bacteria (Fig. 2). The listeriae then begin to move through the host cell cytoplasm at speeds of up to 1  $\mu\text{m}$  per second. In addition to actin, a number of actin-binding proteins such as  $\alpha$ -actinin and fimbrin have been identified in the actin tails. These microfilament-associated proteins form crosslinks with the actin filaments in the tail and the surrounding cytoskeleton [5, 21, 32]. When the listeriae reach the plasma membrane, they form finger-like pseudopodia on the cell surface. If these pseudopods come into contact with neighboring cells, they can be phagocytosed together with the bacteria they contain. Although the bacteria are then surrounded by a double membrane, they can enter the cytoplasm of the new host cell by way of a secreted phospholipase enzyme, thus continuing the infection cycle. In this way, listeria can spread through the tissues of the host organism without coming into contact with the extracellular environment. This elegant spreading mechanism explains why antibodies produced as a result of the humoral immune response are ineffective in eliminating listeria, and why, during the course of an infection, pathogenic listeria can overcome the normally very effective barriers between blood and brain or blood and placenta.

A decisive step for the analysis of the *L. monocytogenes* pathogenicity mechanisms was the establishment of isogenic mutants in each virulence gene. Various laboratories were involved in this work. Using transposon mutagenesis, the production of a nonhemolytic *L. monocytogenes* mutant led to the identification of the listeriolysin gene [25]. Surprisingly, experiments in which the neighboring genes were sequenced and then inactivated by insertion mutagenesis showed that a large proportion of the *L. monocytogenes* virulence genes identified to date lay in a chromosomal gene cluster (see Fig. 1B).

In addition to listeriolysin, this cluster included: the genes of two phospholipases (PlcA and PlcB), enzymes involved in the lysis of the intracellular phagosomal membrane; a so far poorly characterized metalloprotease; and the ActA protein, which will be discussed in more detail below. Interestingly, the expression of the five above-mentioned virulence-associated genes is controlled by a positive regulation factor (PrfA). Since these factors are only produced at temperatures above 30°C, the listeria bacterium appears to be exquisitely adapted to its mammalian host organisms [25]. The contribution of each virulence gene to the total pathogenic potential of *L. monocytogenes* was shown by infection experiments in animal models. Isogenic mutants in each of those genes were either reduced in virulence or were avirulent [7].

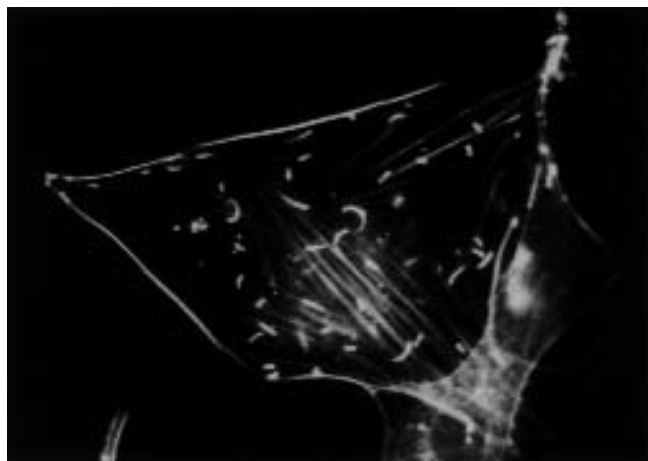

**Fig. 2** Fluorescence micrograph showing epithelial cells infected with *Listeria monocytogenes* wild type revealing the distribution of actin. Note the typical actin "comet tails"

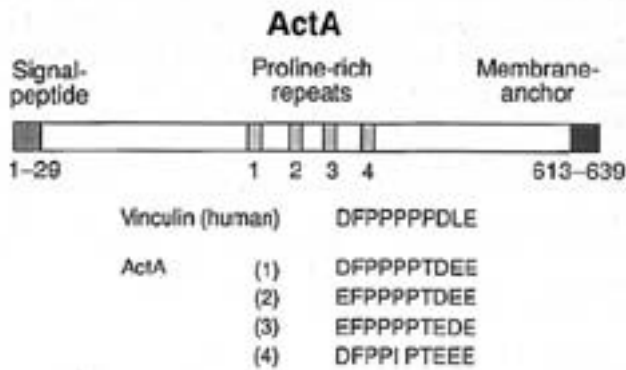
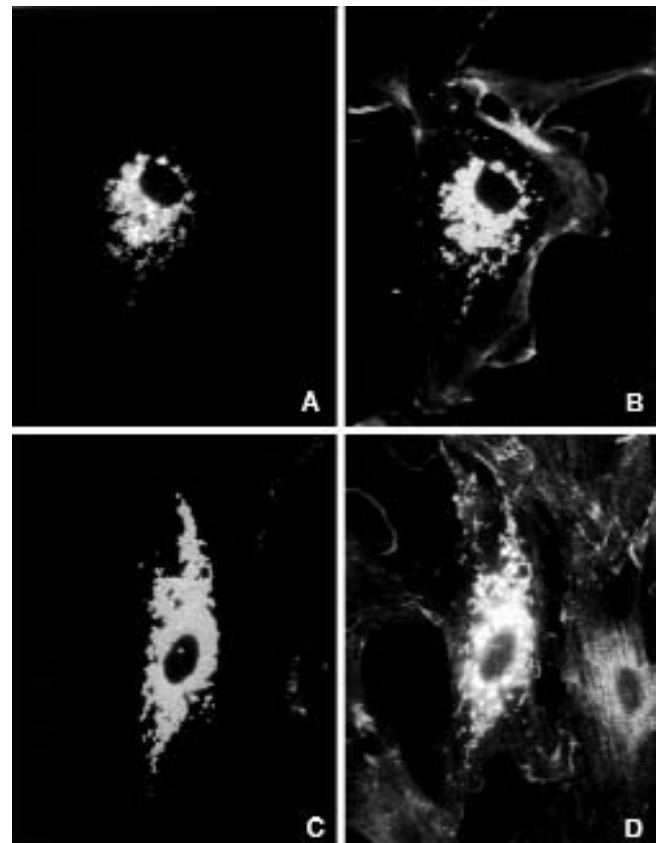

**Fig. 3** Schematic drawing of the ActA protein showing the proline-rich sequences of the central repeat domain and their homology to the related sequence in vinculin, a cytoskeletal protein present in focal contacts

### The ActA protein

Each step in the infection cycle shown in Fig. 1A is in itself extremely interesting and raises a number of questions, the discussion of which would go beyond the scope of this review. Therefore, the following discussion is limited to the ActA protein, which we have studied intensively in recent years, and whose function and mechanism of action are fairly well understood in comparison to the other listerial virulence factors. The function of ActA was in part revealed by the unusual phenotype of an isogenic ActA mutant of *L. monocytogenes* in infected tissue culture cells: although still invasive and capable of multiplying, the ActA mutant no longer spread in the host cell cytoplasm but instead formed microcolonies. Actin recruitment no longer took place in this mutant, which indicated that the listerial ActA protein played a significant role in this process [2, 6, 15]. The ActA polypeptide was found to contain an amino-terminal signal sequence and a carboxy-terminal membrane anchor. A database search turned up a limited homology of the central proline-rich domain to vinculin, a microfilament associated protein (Fig. 3). Shortly after this discovery, it was shown that the motility of listeria in the host cell cytoplasm was attributable to the recruitment of actin and the formation of actin filaments on the bacterial surface [28, 33].

Actin is a highly conserved protein that is found in all eucaryotic cells. It is the main structural component of the cytoskeletal microfilament system. The salient feature of this system, its dynamic reaction in response to extra- or intracellular stimuli, can be attributed to the ability of the actin molecule to reversibly polymerize into a double helical actin filament. Actin therefore serves a pivotal function in various cellular processes such as cell



**Fig. 4** Double fluorescence micrographs of an *actA* transfected epithelial cell. (A) Distribution of the ActA protein in the transfected cell, and (B) distribution of actin in the same field of view. (C) Distribution of ActA in the transfected cell, and (D) overall distribution of  $\alpha$ -actinin in the same field of view. Actin and  $\alpha$ -actinin are located on the ActA-decorated mitochondria in transfected cells

division, chemotaxis, movement, phagocytosis, and secretion. Despite numerous *in vitro* analyses, little is known about the regulation of the proteins involved in the cellular processes that influence actin dynamics.

Actin filaments have a polar structure that can be visualized by decorating it with myosin subfragments. If one observes the organization of actin filaments in motile cell appendages such as the lamellipodia of connective tissue cells, all of the actin filaments can be seen to have the same polarity. The extension of the actin filaments, which occurs through the addition of actin monomers, takes place directly at the plasma membrane. This leads to the local protrusion of the lamellipodia in response to extracellular stimuli. Similarly, the actin filaments in the microvilli of brush border epithelia all have identical polarity, and extension of the microvilli, as during regeneration, takes place at their tips by the deposition of actin monomers directly underneath the plasma membrane. The mechanisms and/or proteins responsible for these processes are unknown.

Actin filaments in the tails induced by listeria have an analogous polarity, and the deposition of actin monomers takes place directly on the surface of the bacteria. This strongly suggests that listeriae utilize the host cell's machinery for actin filament formation to their own advantage. The elucidation of the mechanisms by which actin filaments are formed at the bacterial surface would therefore contribute significantly to our understanding of how eucaryotic cells normally control the assembly and dismantling of actin filaments. In this regard it was of interest to investigate the ActA protein in more detail. The first question we asked was whether or not this bacterial factor alone was sufficient for the recruitment of actin filaments on the bacterial surface. To address this problem, an experimental system was required that allowed the analysis of ActA activity in the absence of other bacterial factors. Therefore, ActA was expressed in eucaryotic cells [23]. To our surprise, the ActA protein was distributed in point-like clusters in the transfected cells and co-localized with the mitochondria. Analysis of the actin distribution in the transfected tissue culture cells showed that actin filaments were attached to the ActA-decorated mitochondrial surface (Fig. 4). For the aforementioned transfection experiments, the complete ActA gene including the signal sequence and membrane anchor was used. When an ActA construct without a membrane anchor was employed, the ActA remained dispersed within the cytoplasm of the transfected cells, indicating that the ActA membrane anchor was responsible for the mitochondrial localization. In addition to actin filaments, microfilament-associated proteins such as  $\alpha$ -actinin (Fig. 4) and fimbrin were localized to the ActA-decorated mitochondria in transfected cells. We therefore concluded that ActA, regardless of whether it is anchored to the bacterial or the mitochondrial surface, can induce the recruitment of actin filaments and additional microfilament-associated proteins. This proved that ActA alone is sufficient to initiate a reorganization of the microfilament system, and suggested that this bacterial factor can be considered a prototype of an actin nucleator [23]. Furthermore, the mitochondrial targeting system also opened the possibility of investigating the functional domain structure of the ActA protein by using different ActA constructs in transfection experiments (see below). Using other experimental approaches, these results were previously confirmed [9, 16, 31].

### Profilin, VASP, Mena

During the course of this work we also attempted to identify potential ActA-binding host cell-derived factors that might be involved in actin filament nucleation on the bacterial surface. Analysis of the protein composition of

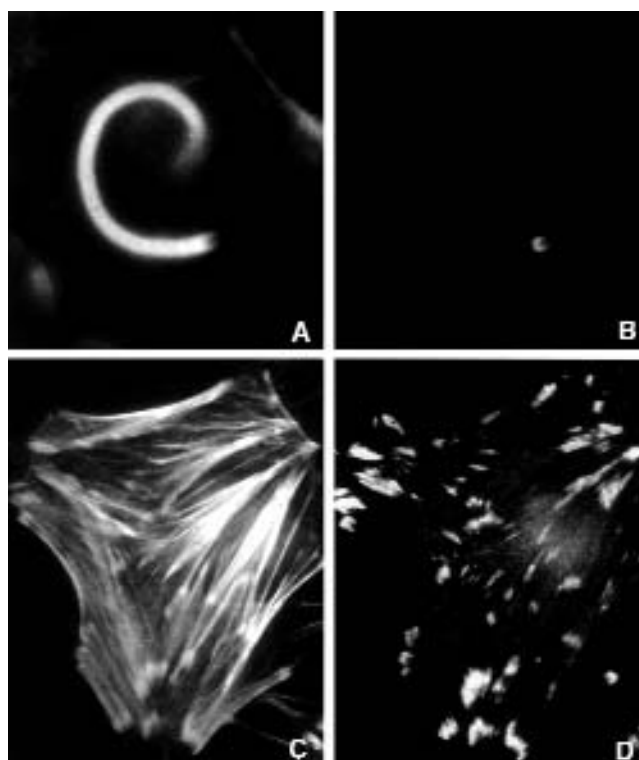

**Fig. 5** (A, B) Detection of VASP on the surface of intracellular listeria. Double fluorescence micrographs of a portion of an epithelial cell infected with *Listeria monocytogenes* at higher magnification showing: (A) the actin labelling of a typical "comet tail" and (B) the distribution of VASP in the same field of view. (C, D) Double fluorescence micrographs of an epithelial cell showing: (C) the distribution of actin and (D) that of VASP in the same field of view. Note the accumulation of VASP in focal contacts

the microfilament elements recruited by listeria showed that different actin-binding proteins such as  $\alpha$ -actinin and fimbrin were localized at the ends of the actin tail; this observation led to the conclusion that these proteins do not interact directly with the bacterial surface, i.e., with ActA [5, 32]. An exception to this rule was profilin, which was shown to have a polar distribution on the surface of motile intracellular listeriae [34]. From this observation it was suggested that profilin may be required for the polymerization of cellular actin on the bacterial surface. In vitro, profilin binds monomeric actin and catalyzes nucleotide exchange (ADP for ATP) on the actin molecule. Because the polymerization of ADP-actin proceeds more slowly than for ATP-actin, profilin can promote actin polymerization in the presence of excess ADP-actin by means of this nucleotide exchange. However, in a cell-free system it was not possible to establish a direct association between profilin and listeria. It was thus concluded that an additional host cell factor must be involved in the interaction between ActA and profilin.

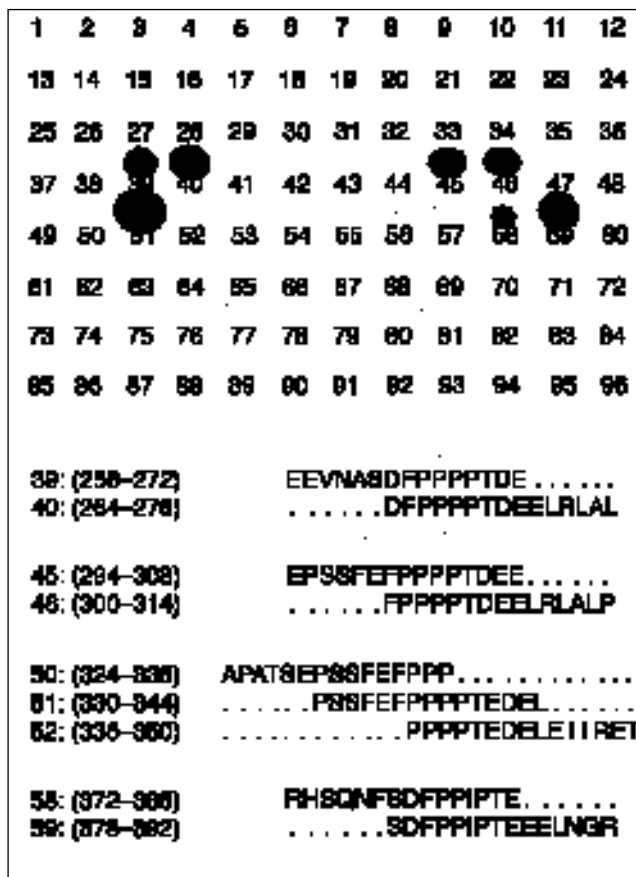

**Fig. 6** Identification of the VASP binding position on the ActA protein with the help of the peptide spot synthesis method. The numbers from 1 to 96 mark the spots on a filter membrane containing the immobilized, overlapping synthetic peptides that together compose the entire ActA sequence. The bound, radioactively-labeled VASP was revealed with the help of an X-ray film. VASP binds specifically to the peptides that contain polyproline, as shown by the list of positive peptides

We carried out a comprehensive series of tests with different antibodies that react with microfilament-associated proteins to search for this missing protein. The most promising candidate could be identified as a protein known as VASP, the vasodilator-stimulating phosphoprotein [3]. VASP was originally identified as an *in vitro* substrate for cAMP and cGMP-dependent protein kinases in thrombocytes. Moreover, it is virtually ubiquitous in mammalian cells as a microfilament-associated "focal contact protein", as well as being localized in the active margins of lamellipodia as shown in Fig. 5. We showed that VASP was localized at one pole of intracellular motile listeriae and, furthermore, that purified VASP binds to ActA *in vitro* [3]. In the meantime, the natural VASP binding partner in the cell was identified as profilin [27]. It could therefore be concluded that, by binding to ActA and profilin, VASP establishes a direct connection between intracellular listeriae and the cytoskeletal

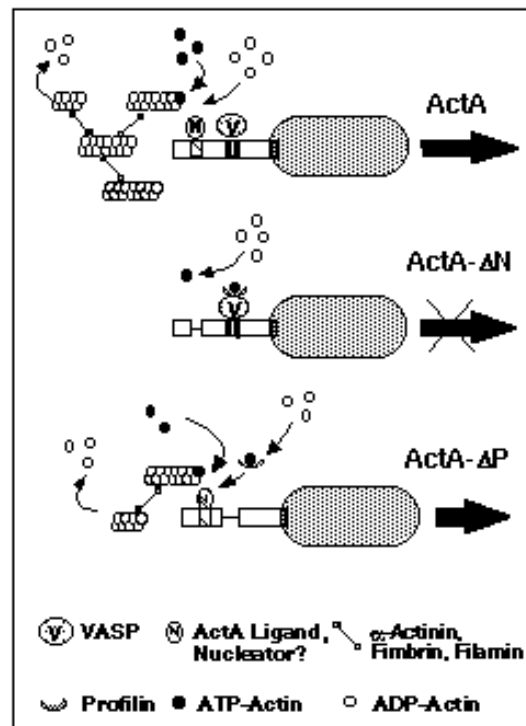

**Fig. 7** A model for ActA-mediated actin filament formation. ActA recruits VASP that in turn binds profilin. ActA also recruits another, as yet unknown, ligand or complex which possibly represents the actual actin nucleator. Profilin promotes nucleotide exchange within actin (ADP for ATP) and thus raises the concentration of polymerizable actin in the immediate vicinity of the ActA-bound nucleator. The resulting actin filaments are diagonally cross-linked with actin-binding proteins such as  $\alpha$ -actinin, fimbrin and filamin, and thus the polymerization process in itself can be considered the propelling force for bacterial motility in the cytoplasm. In the absence of the amino-terminal domain (ActA- $\Delta$ N) ActA still recruits VASP but actin filaments cannot be formed. This mutant forms micro-colonies in infected cells and is incapable of spreading intra- or intercellularly. An *actA* mutant from which the proline-rich repeat domain has been deleted (ActA- $\Delta$ P) is only capable of forming short actin tails in infected cells and has a markedly reduced intracellular motility. Thus, VASP substantially enhances the effectivity of the ActA-induced actin filament formation

components of the host cell. More recently another microfilament-associated protein, Mena, was identified to interact directly with both, ActA and profilin. Both proteins, VASP and Mena, belong to the newly discovered Ena/VASP family, whose members share a similar organization [11].

The VASP-binding domain on the ActA molecule was located using the mitochondrial targeting system. Unlike complete ActA, derivatives of ActA lacking the central proline-rich repeats do not recruit VASP in transfected cells although they can still recruit actin filaments to a small degree. Further analysis of the N-terminal region of ActA resulted in the identification of a second domain that, independent of the VASP-binding domain, is essential for the recruitment of actin filaments [24].

The method of parallel spot synthesis of peptides on membrane supports [8] proved to be useful for the detailed characterization of VASP/ActA binding. Since we had used this technique for the epitope analysis of monoclonal antibodies, we already had a complete set of overlapping peptides (peptide length: 15 amino acid groups; 96 peptides in total), together comprising the whole of the ActA molecule, immobilized as spots on a membrane. The incubation of this membrane with [<sup>32</sup>P]-phosphorylated VASP (i.e., radioactively labeled) enabled us to identify the peptides to which VASP binds (Fig. 6), which in each case were the polyproline-containing peptides within the proline-rich repeat domain. These findings confirmed the experiments discussed above in which different ActA constructs were tested in the mitochondrial targeting system. Additional experiments using the peptide spot synthesis method allowed an even more detailed analysis of the VASP-binding domain in the ActA molecule, revealing that the proline-rich motif of ActA represents a novel polyproline ligand also present in cytoskeletal proteins such as vinculin and zyxin [22]. In addition the N-terminal domain of VASP and Mena, termed Ena/VASP homology domain 1 (EVH1), mediates the binding to this proline-rich ligand [11, 22].

On the basis of the aforementioned results, two *L. monocytogenes* mutants with specific chromosomal deletions within the *actA* gene were produced in collaboration with Trinad Chakraborty and coworkers at the University of Giessen. The potential actin recruiting domain at the amino-terminal end of the ActA molecule (amino acids 129-151) was deleted in one case, and the VASP-binding peptides (amino acids 265-389) in the other. Compared to *L. monocytogenes* wild type, the two mutants revealed unusual phenotypes in infected tissue culture cells. The N-terminal deletion resulted in an abrogation of motility comparable to an ActA deletion mutant. Deletion of the central proline-rich domain led to an impaired, or slower intracellular motility. These latter listeria mutants had very short actin tails. Both mutants were attenuated (i.e., had reduced virulence) in mouse infection models. Each of the two domains identified in the ActA molecule therefore plays an important role in the development of the full pathogenic potential of *L. monocytogenes*.

The model shown in Fig. 7 is based on the results described here. Although actin recruitment also takes place in the absence of VASP, the binding of VASP to ActA considerably enhances the efficiency of actin filament formation and thus the motility of the intracellular listeriae. In comparison to the mutants, the wild type can spread more rapidly within the infected tissue or host, and therefore has an increased chance of eluding the immune system. Our current research activities are being concentrated on the amino-terminal ActA domain that is

vital for actin filament recruitment. Because it so far has not been possible to show a direct interaction between ActA and actin, it appears likely that the ActA protein recruits one or more additional host cell factors that are responsible for the efficient nucleation of actin filaments. Cytoplasmic extracts derived from *Xenopus* oocytes or platelets that support listeria-induced actin recruitment and moreover motility have turned out to be powerful systems to dissect the listeria-induced actin-based motility [18, 30, 34, 36]. An eight polypeptide complex containing two actin-related proteins, Arp2 and Arp3, was recently identified in platelet extracts to be involved in actin filament formation on the surface of listeria [36]. In conclusion, even though we are far away from understanding the mechanisms of actin filament formation in detail, the analysis of the listeria-induced actin-based motility has already enabled us to gain quite detailed insights into this cellular process.

**Acknowledgements** The authors wish to thank Trinad Chakraborty and his colleagues at the Institute of Medical Microbiology, University of Giessen, Germany, without whom the work of this review would have not been possible. In addition, we would also like to thank all members of our laboratory who have contributed to the work presented in this review, Ronald Frank for the peptide spot synthesis and David Monner for critically reading the manuscript. The work in our laboratory was supported by BMBF (01GB 9506), the Deutsche Forschungsgemeinschaft and Fonds der Chemischen Industrie.

## References

1. Bernadini ML, Mounier J, Hauteville D, Coquis-Rondon M, Sansonetti PJ (1989) Identification of *icsA*, a plasmid locus of *Shigella flexneri* that governs bacterial intra- and intercellular spread through interaction with F-actin. Proc Natl Acad Sci USA 86:3867-3871
2. Brundage RA, Smith GA, Camilli A, Theriot JA, Portnoy DA (1993) Expression and phosphorylation of the *Listeria monocytogenes* ActA protein in mammalian cells. Proc Natl Acad Sci USA 90:11890-11894
3. Chakraborty T, Ebel F, Domann E, Niebuhr K, Gerstel B, Pistor S, Temm-Grove, CJ, Jockusch BM, Reinhard M, Walter U, Wehland J (1995) A focal adhesion factor directly linking intracellular motile *Listeria monocytogenes* and *Listeria ivanovii* to the actin based cytoskeleton of mammalian cells. EMBO J 14:1314-1321
4. Chakraborty T, Wehland J (1997) The host cell infected with *Listeria monocytogenes*. In: Kaufmann SHE (ed) Host Responses to Intracellular Pathogens. RG Landes Co, pp 271-290
5. Dabiri GA, Sanger JM, Portnoy DA, Southwick, FS (1990) *Listeria monocytogenes* moves rapidly through the host-cell cytoplasm by inducing directional actin assembly. Proc Natl Acad Sci USA 87:6068-6072
6. Domann E, Wehland J, Rohde M, Pistor S, Hartl M, Goebel W, Leimeister-Wächter M, Wünsch M, Chakraborty T (1992) A novel

- bacterial virulence gene in *Listeria monocytogenes* required for host cell microfilament interaction with homology to the proline-rich region of vinculin. *EMBO J* 11:1981-1990
7. Finlay BB, Cossart P (1997) Exploitation of mammalian host cell functions by bacterial pathogens. *Science* 276:718-725
  8. Frank R (1992) Spot-synthesis: An easy technique for the positionally addressable, parallel chemical synthesis on a membrane support. *Tetrahedron* 48:9217-9232
  9. Friederich E, Gouin E, Hellio R, Kocks C, Cossart P, Louvard D (1995) Targeting of *Listeria monocytogenes* ActA protein to the plasma membrane as a tool to dissect both actin-based cell morphogenesis and ActA function. *EMBO J* 14:2731-2744
  10. Gaillard JL, Berche P, Frehel C, Gouin E, Cossart P (1991) Entry of *Listeria monocytogenes* into cells is mediated by internalin, a repeat protein reminiscent of surface antigens from Gram-positive cocci. *Cell* 65:1127-1141
  11. Gertler FB, Niebuhr K, Reinhard M, Wehland J, Soriano P (1996) Mena, a relative of VASP and *Drosophila* Enabled, is implicated in the control of microfilament dynamics. *Cell* 87:227-239
  12. Gray ML, Killinger AH (1966) *Listeria monocytogenes* and listeric infections. *Bacteriol Rev* 30:309-382
  13. Kaufmann SHE (1993) Immunity to intracellular bacteria. *Annu Rev Immunol* 11:129-163
  14. Kobe B, Deisenhofer J (1994) The leucine-rich repeat: a versatile binding motif. *Trends Biochem Sci* 19:415-421
  15. Kocks C, Gouin E, Tabouret M, Berche P, Ohayon H, Cossart P (1992) *Listeria monocytogenes*-induced actin assembly requires the actA gene product, a surface protein. *Cell* 68:521-531
  16. Lasa I, David V, Gouin E, Marchand JB, Cossart P (1995) The amino-terminal part of ActA is critical for the actin-based motility of *L. monocytogenes*, the central proline-rich region acts as a stimulator. *Mol Microbiol* 18:425-436
  17. Lingnau A, Domann E, Hudel M, Bock M, Nichterlein T, Wehland J, Chakraborty T (1995) Expression of the *Listeria monocytogenes* EDG *inlA* and *inlB* genes whose products mediate bacterial entry into tissue culture cell lines, by *prfA*-dependent and-independent mechanisms. *Infect Immun* 63:3896-3903
  18. Marchand JB, Moreau P, Paoletti A, Cossart P, Carlier MF, Pantaloni D (1995) Actin-based movement of *Listeria monocytogenes* actin assembly results from the local maintenance of uncapped filament barbed ends at the bacterium surface. *J Cell Biol* 130:331-343
  19. Mengaud J, Ohayon H, Gounon P, Mege RM, Cossart P (1996) E-cadherin is the receptor for internalin, a surface protein required for entry of *Listeria monocytogenes* into epithelial cells. *Cell* 84:923-932
  20. Montecucco C, Papini E, Schiavo G (1994) Bacterial protein toxins penetrate cells via a four-step mechanism. *FEBS Lett* 346:92-98
  21. Niebuhr K, Chakraborty T, Rohde M, Gazlig T, Jansen B, Köllner P, Wehland J (1993) Localization of the ActA polypeptide of *Listeria monocytogenes* in infected tissue culture cell lines: ActA is not associated with actin comets. *Infect Immun* 61:2793-2802
  22. Niebuhr K, Ebel F, Frank R, Reinhard M, Domann E, Carl UD, Walter U, Gertler F, Wehland J, Chakraborty T (1997) A novel proline-rich motif present in ActA of *Listeria monocytogenes* and cytoskeletal proteins is the ligand of EVH1 domain, a protein module present in the Ena/VASP family. *EMBO J* 16:5433-5444
  23. Pistor S, Chakraborty T, Niebuhr K, Domann E, Wehland J (1994) The ActA protein of *Listeria monocytogenes* acts as a nucleator inducing reorganization of the actin cytoskeleton. *EMBO J* 13:758-763
  24. Pistor S, Chakraborty T, Walter U, Wehland J (1995) The bacterial actin nucleator protein ActA of *Listeria monocytogenes* contains multiple binding sites for host microfilament proteins. *Current Biology* 5:517-525
  25. Portnoy DA, Chakraborty T, Goebel W, Cossart P (1992) Molecular determinants of *Listeria monocytogenes* pathogenesis. *Infect Immun* 60:1263-1268
  26. Reinhard M, Halbrügge M, Scheer U, Wiegand C, Jockusch BM, Walter U (1992) The 46/50 kDa phosphoprotein VASP purified from human platelets is a novel protein associated with actin filaments and focal contacts. *EMBO J* 11:2063-2070
  27. Reinhard M, Giehl K, Abel K, Haffner C, Jarchau T, Hoppe V, Jockusch BM, Walter U (1995) The proline-rich focal adhesion and microfilament protein VASP is a ligand for profilins. *EMBO J* 14:1583-1589
  28. Sanger JM, Sanger JW, Southwick FS (1992) Host cells actin assembly is necessary and likely to provide the propulsive force for intracellular movement of *Listeria monocytogenes*. *Infect Immun* 60:3609-3619
  29. Schuchat A, Swaminathan B, Broome CV (1991) Epidemiology of human listeriosis. *Clin Microbiol* 4:169-183
  30. Smith GA, Portnoy DA, Theriot JA (1995) Asymmetric distribution of the *Listeria monocytogenes* ActA protein is required and sufficient to direct actin-based motility. *Mol Microbiol* 17:945-951
  31. Smith GA, Theriot JA (1995) *Listeria monocytogenes* ActA protein controls the rate of actin-based motility, the percentage of moving bacteria, and the localization of vasodilator-stimulated phosphoprotein and profilin. *J Cell Biol* 135:647-660
  32. Temm-Grove CJ, Jockusch BM, Rohde M, Niebuhr K, Chakraborty T, Wehland J (1994) Exploitation of microfilament proteins by *Listeria monocytogenes*: microvillus-like composition of the "comet tails" and vectorial spreading in polarized epithelial sheets. *J Cell Sci* 107:2951-2960
  33. Theriot JA, Mitchison TJ, Tilney LG, Portnoy DA (1992). The rate of actin-based motility of intracellular *Listeria monocytogenes* equals the rate of actin polymerization. *Nature* 357:257-260
  34. Theriot JA, Rosenblatt J, Portnoy DA, Goldschmidt-Clermont PJ, Mitchison TJ (1994) Involvement of profilin in the actin-based motility of *Listeria monocytogenes* in cells and in cell-free extracts. *Cell* 76:505-517
  35. Tilney LJ, Portnoy DA (1989) Actin filaments and the growth, movement and spread of the intracellular parasite *Listeria monocytogenes*. *J Cell Biol* 109:1597-1608
  36. Welch MD, Iwamatsu A, Mitchison TJ (1997) Actin polymerization is induced by Arp2/3 protein complex at the surface of *Listeria monocytogenes*. *Nature* 385:265-269