



Balasubramani, Nimal Kumar and Sitnikova, Elena and Li, Shuguang (2016) On understanding the applicability of Mohr-Coulomb failure hypothesis for composite materials using UnitCells©. In: 5th Aircraft Structural Design Conference, 4-6 October 2016, Manchester, UK.

Access from the University of Nottingham repository:

<http://eprints.nottingham.ac.uk/52460/1/On%20Understanding%20the%20Applicability%20of%20Mohr-Coulomb%20Failure%20Hypothesis%20for%20Composite%20Materials%20using%20UnitCells.pdf>

Copyright and reuse:

The Nottingham ePrints service makes this work by researchers of the University of Nottingham available open access under the following conditions.

This article is made available under the University of Nottingham End User licence and may be reused according to the conditions of the licence. For more details see: http://eprints.nottingham.ac.uk/end_user_agreement.pdf

A note on versions:

The version presented here may differ from the published version or from the version of record. If you wish to cite this item you are advised to consult the publisher's version. Please see the repository url above for details on accessing the published version and note that access may require a subscription.

For more information, please contact eprints@nottingham.ac.uk

On Understanding the Applicability of Mohr-Coulomb Failure Hypothesis for Composite Materials using UnitCells©

Nimal Kumar Balasubramani^a, Elena Sitnikova^b, Shuguang Li^c
Faculty of Engineering, The University of Nottingham, University Park,
Nottingham NG7 2RD, UK

Abstract

The applicability of Mohr-Coulomb (M-C) failure hypothesis for anisotropic composite materials is re-examined in this paper. Mohr-Coulomb failure theory has been widely referred to in the literature to study the failure of unidirectional (UD) fibre reinforced composites under transverse loading including the renowned Puck's criteria. This has been partially validated based on the experimental correlations with the predictions made by the M-C criterion for a few set of test cases, which remains a debatable way of formulating composites failure criterion. It is brought to attention that Mohr utilised the concept of principal stresses in constructing principal circles and assumed that the outermost circle represents the critical state of failure. This hypothesis and its derivative "failure is dictated by the stresses acting on the fracture surface" have thus been used for formulating the criterion for isotropic materials that exhibit brittle fracture characteristics. However, the concept of principal stresses is not employable in the analysis of composites. Hence, the same hypothesis may not be applicable in studying composite materials. Also, the micromechanical aspects that lead to failure have not been taken into consideration in this hypothesis which can lead to incorrect predictions in the case of composite materials.

The capability of an appropriately representative unit cell model in better understanding the micromechanical aspects and the implications of the hypothesis is studied by attempting micromechanical analysis of UD composites through UnitCells© tool. It is utilised to locate stress concentrations within the unit cell from which the likely angle of the fracture surface can be identified. It has also been shown that the stress concentrations could help locate the fracture angle for UD composite materials as a sufficient but not a necessary requirement due to the presence of non-linear behaviour before fracture. If one wishes to employ M-C failure hypothesis to formulate a failure criterion, the assumption that the failure is determined by the stresses exposed on fracture surface has to be made with caution.

Keywords: Mohr-Coulomb criterion, Failure criterion, Fracture surface, UD composites, Puck criterion, Mohr's circle, Principal stresses, Micromechanics, RVE, UnitCells.

1. Introduction

Since the first commercial use of aircraft on January 1st, 1914, the aviation sector has grown strongly over the past century and is of great economic and social importance. Aircraft of today use hydrocarbon based fossil fuels and thus add to anthropogenic CO₂ emissions resulting in climate change. The current contribution of aviation sector to the global CO₂ emissions is approximately 2% which has been estimated to grow to around 3-4% per year in line with the projected increase in passenger numbers [1]. Recognising this challenge to mitigate the emissions, global aviation organisations have called for steep reductions in CO₂ emissions [1][2]. Given the long development cycle and lifetime of aircraft, it is imperative that even those under design today need to undergo dramatic weight reductions in order to reach these targets. Due to high specific properties and also the ability to tailor the required properties optimally for the specific application, fibre reinforced composite laminate materials have gradually replaced conventional materials like aluminium in the design of aerospace structures. The directional nature of stiffness and strength in fibres provides a greater motivation for fabricating them into such laminates consisting of thin unidirectional (UD) laminae with different reinforcement orientations.

^a Postgraduate Student, MSc Aerospace Technologies, University of Nottingham; eaxnkb@nottingham.ac.uk

^b Postdoctoral Research Fellow, University of Nottingham; Elena.Sitnikova@nottingham.ac.uk

^c Professor of Aerospace Composites, University of Nottingham; Shuguang.li@nottingham.ac.uk

Owing to their greater adoption over the recent years, weight savings of up to 20% have been reported in the aircraft designs [3]. However, there is still significant conservatism surrounding their use caused by the difficulty in predicting their failure. Unlike isotropic materials whose failure modes have been understood to a greater extent through empirical studies, the failure response of the composites is not predicted completely yet. The tendency of laminates to fail progressively from initial cracking to final fracture means that a cascading of damage modes is encountered during a typical loading scenario. Only by achieving better understanding of the damage mechanisms involved, comprehensive failure criteria can be established to aid in the optimal design of a composite component or structure.

Thanks to the surge in research efforts in this area, a number of failure theories and their variations [4] are being proposed since 1950's for composite materials in an attempt to predict their failure and hence aid in structural design. In order to establish their level of maturity in predicting failure, a series of benchmarking exercises under the name World-Wide Failure Exercise [5][6] is being conducted in the composites community. The findings of the study have established so far that there is neither a comprehensive theory addressing the entire range of design combinations possible (choice of fibres and matrix, volume fractions, layer dimensions, fibre orientation, layup configurations and practical loadings scenarios) nor a consensus among the theories in predicting a particular failure event. This uncertainty surrounding failure prediction in composites is bound to have a cascading effect on the cost to design, build and run the aircraft. Besides conservatism, weakness in predictive modelling also dramatically increases the length and expense of design iteration and certification. This has resulted in an undeniable need to improve failure models for composites and this will only come through an improved understanding of the fundamental damage mechanisms and making hypothesis that better reflect these damage mechanisms in composite structures.

Many composite failure criteria in practice including Tsai-Wu [7] are based on the yield criteria of von Mises or Hill which hold good only for ductile isotropic materials. The composite materials, on the other hand, fail in a brittle manner and this encouraged Puck [8] to use the failure hypothesis of Mohr [9] as a guideline in formulating a failure criterion. Although it was earlier acknowledged by Hashin [10], it was not accomplished in a fully functioning failure criterion and instead he resorted to the stress invariant based approach. For the purpose of distinguishing between failure modes in the fibre and matrix and the contributing stress components, Hashin [10] assumed that "the failure is dictated by the stresses exposed on the fracture surface". This hypothesis has been carried forward in the Puck's criteria citing the availability of enormously increased computer capacities making it desirable to develop and apply these ideas further to study the Inter-Fibre Failure (IFF) or matrix failure [11]. The distinctive feature of Puck's criterion is that it identified the different modes of failure in composites and used the information in formulating distinct failure criterion for each mode. Further, it involved the calculation of fracture plane angle of IFF under the transverse loading conditions. Apparently, it was one of the best failure theories found through World-Wide Failure Exercise-I [5] as the predicted failure envelopes correlated comparatively well with the test results than the other participants. Even, at a more recent World-Wide Failure Exercise-II [12], a theory by the codename LaRC05 [13] which adopted Mohr's hypothesis for matrix failure "was able to capture almost all the features exhibited in the test results" [6]. Although the adoption of Mohr's hypothesis seems to have improved the predictions made by these theories [8][13], there is still a great scope for improvement that requires further explanation on the differences observed. Hence, a fresh look at the fundamental hypothesis of Mohr-Coulomb theory of failure and its applicability to composites is desired. This would greatly help develop more comprehensive failure criteria that better capture the various damage mechanisms.

Traditionally, effective material properties such as strength and stiffness used in designing composite materials and structures are obtained by experimentally testing the material and any design improvement has been achieved empirically and by qualitative judgement. However, the mechanical behaviour of composite materials is different from that of the conventional engineering materials because of their inherent heterogeneity. Following a typical design sequence of composite structure (fibres and matrix → unidirectional lamina → laminate → laminated structure), it can be seen that the composite materials are of such immense variety and hence proper analysis, rather than experimentation and empiricism, would be the practical procedure to obtain their effective properties. The viewpoint of micromechanics [14] enables studying the mechanical behaviour of composite materials much more

conveniently under the action of loads. Micromechanics approach allows predicting the properties of such heterogeneous composite materials on the basis of the geometries and properties of the individual constituent materials by approximately homogenising the material. As an added advantage, understanding the micromechanics of materials allows evaluating the local stress and local strain fields in the constituents for given macroscopic load states, constituent properties and geometries. Such knowledge is especially important in understanding and describing the material damage and failure. These two aspects of micromechanics are of interest in meeting the objectives of the paper.

In micromechanics approach, a common way of homogenising the composite material while retaining the heterogeneity present between fibres and matrix has been done by representing the composite material through representative volume elements (RVEs) or unit cells (UCs). An RVE is the smallest volume of a heterogeneous composite material that is of sufficient size for representing the effective properties of the constituents in a statistical sense necessary for obtaining the homogenised material behaviour. When such a volume or the microstructure under consideration show up in a periodic manner in the material, UCs can be a more convenient form of RVE as demonstrated in [15]. One can imagine that a three-dimensional repetition of UCs would yield the whole material and by establishing appropriate boundary conditions for each UC, the micromechanical analysis of the whole material can be performed. Figure 1 below illustrates the concept of unit cell using a square periodic element.

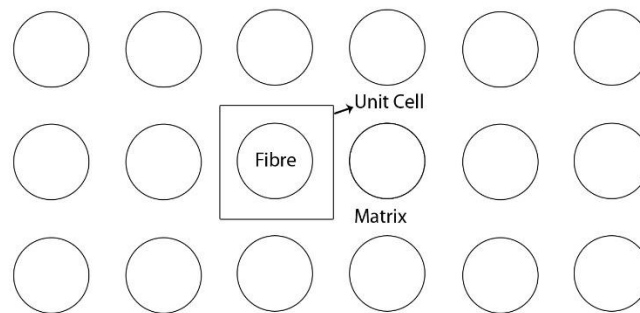

Figure 1. Square Unit Cell

The UCs can be used to study the material properties by a range of methods [16] viz. analytical methods, numerical methods such as finite element (FE) and finite difference (FD), boundary element methods, variational principle models, elasticity approach and also semi-empirical methods such as Halphin-Tsai model. This research work, in fact, attempts at revisiting the fundamental hypothesis of Mohr-Coulomb theory of failure and understand its extend of applicability to composite materials by conducting finite element based micromechanical analysis using UnitCells© as a vehicle. Chapter 1 has introduced the background information on the Mohr's hypothesis and the micromechanical modelling approach used to clearly lay down the motive of this research. Chapter 2 focuses on the history of research works in formulating failure criteria for fibre reinforced composite laminate materials providing a critical understanding of the Mohr-Coulomb failure hypothesis. Chapter 3 provides an overview of the micromechanical modelling tool UnitCells© utilised in this work and the FE analysis methodology has been elaborated in chapter 4. The simulation results obtained using the FE method are presented and further discussed in chapter 5. Finally, the conclusions are drawn out in chapter 6.

2. Mohr-Coulomb Failure Hypothesis

Dating back to the classic literature, Coulomb (1773) [17] and Mohr (1900) [9] separately proposed hypotheses on the fracture of brittle materials. Timoshenko [18] and Nadai [19] has provided a detailed account on the evolution of these hypotheses. However, to the knowledge of the authors, it was Paul [20] in 1961 who referred to them together as "Coulomb-Mohr theory of fracture" and modified the failure criterion to better explain the experimental observations on compression, tension and shear tests of brittle material such as cast iron. Since then, the hypothesis and the associated failure criterion have been widely referred to in the literature as Mohr-Coulomb or Coulomb-Mohr failure theory. In order to better understand the intricacies and the basis of the hypothesis and avoid any potential

misinterpretation by the subsequent researchers, back-to-source reading has been attempted to the possible extent.

Coulomb [17] in his experimental work on establishing the compressive strength of sandstone observed that the test specimens fractured at an angle to the plane of applied longitudinal force. He assumed that the fracture is due to sliding/shearing in that plane when the component of the applied stress (σ) along this plane exceeds the cohesive resistance in shear (τ). However, to achieve better alignment with the experimental results, he proposed that this sliding/shearing action is impeded by friction along the plane and introduced the parameter, coefficient of friction (μ). Also, Coulomb believed that the strength of the material under shear is equal to that of tension. Accordingly, he proposed that failure depends only upon the tractions acting on the failure surface and postulated the failure function for ultimate shear strength (τ^*) or ultimate tensile strength as

$$\tau + \mu\sigma \leq \tau^* \quad (1)$$

where the two parameters τ^* and μ are material specific and can be determined by the intercepts and slope of the Coulomb failure envelope as shown in figure 2 below.

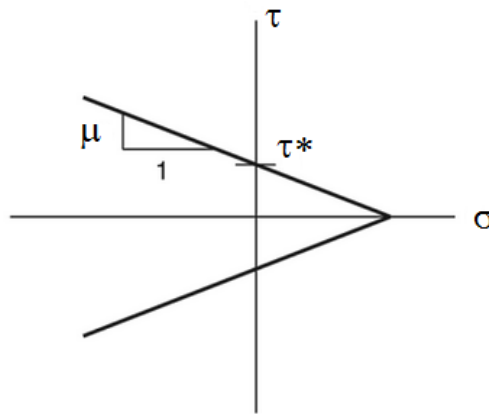

Figure 2. Coulomb failure envelope.

In order to study Mohr's failure theory [9] which is based on Mohr's earlier work [21] on graphical representation of stress at a body point (what is now referred to as Mohr's Circle), the concept of principal stress introduced by Cauchy [22] has to be understood. Cauchy showed that principal stresses can be used to characteristically represent the stresses acting on a body point and it is invariant to the plane of action. One can readily understand that finding the maximum and minimum values and the corresponding planes of the stress state is an important aspect from the design considerations and the concept of principal stress and principal plane is a useful 'reference' tool to find such information. Thus the principal planes and principal stresses can be solely relied upon to understand the failure in isotropic materials. However, as widely known, the concept of principal stresses is not useful in composite materials which have another 'reference' axis inherent to the material itself. Also, the principal stresses computed in composite materials in the similar way to isotropic materials may not be the maximum and minimum values which instead depend on the fibre orientations in the UD composite laminates. Hence, any method or hypothesis that was based on the information of principal stresses is expected to be made with caution in studying composite materials that doesn't behave the same way.

At a time when there weren't any computational tools to perform numerical calculations (like the computers and calculators of today), graphically depicting the stress states was of interest to Culmann [23] in order to perform calculations using the drafting tools available. Culmann's circle was in fact the precursor to "Mohr's circle", the concept of using circles to analyse the stress state of a body point. Further coverage about this is available in Timoshenko's book, p. 195 [18]. Mohr extended Culmann's circle concept to three-dimensional case and used principal stresses to plot "Mohr's circles" as shown in figure 3 below. One can find detailed procedure of constructing Mohr's circle in many standard textbooks on strength of materials and solid mechanics. Hence, focus is resorted to aspects that are important to the case made here.

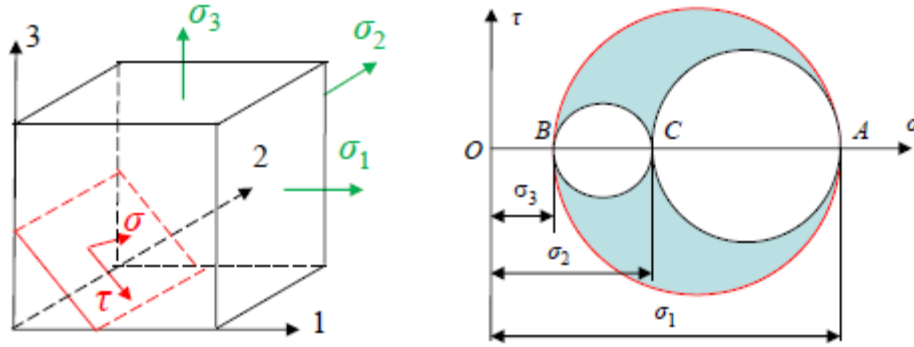

Figure 3. Depiction of 3D stress state indicating principal stresses and directions and the corresponding 3D Mohr circle.

Some of the major assumptions made by Mohr in his further extension of Mohr circle to his failure theory and their implications when considered for composite materials are as follows:

1. The outermost circle on the stress plane is the most critical one (shown in red in figure 3) and failure happens beyond this stress state. This assumption has also been verified based on the experimental results of uniaxial testing of commonly used (isotropic) materials at that time viz. iron and steel.

Implication: It is obvious that the largest and outermost circle has diameter equal to the difference between largest (σ_1) and smallest (σ_3) principal stresses. In isotropic materials, these principal planes are the only planes that possess maximum and minimum stress values and hence it could be acceptable to assume that they contribute to the failure. However, in anisotropic composite laminate materials, it is not applicable similar to the concept of principal stress as discussed earlier. Also, testing the material under uniaxial stress states might have satisfied the assumption and its consequence that the intermediate principal stress (σ_2) doesn't contribute to failure. However, under a multi-axial stress state involving stresses in the intermediate principal direction (2-2'), the same cannot be true and this has not been attempted by Mohr to be verified experimentally.

2. Failure is dictated by the stresses acting on the fracture surface/plane.

Implication: This assumption is basically a derivative of the above assumption and as such the fracture plane determined by this method may not be a true and accurate reflection of the reality.

These aspects could potentially be overlooked when composites are treated from macro-mechanics or strength of materials point of view. However, when looked from micromechanics view of composite materials, they often contain microscopic defects in the form of voids, micro-cracks which arise during material processing and could have a potential impact on the predictions. Also, Inter-Fibre fracture (IFF) as defined by Puck [8] is a macroscopic crack which runs parallel to the fibres and separates an isolated UD layer into two pieces. Such a macroscopic separation is often preceded by micro-mechanical damage of the matrix or the fibre-matrix interface. Considering these factors and their implications, applying Mohr's hypothesis to composites as done by Puck is likely to produce the predictions that could be different from the true failure event.

For instance, in predicting the fracture plane out of all possible fracture planes under Mode-C of Inter-Fibre Failure (IFF), Puck used stress exposure factor (f_E) to find the stress action plane with the highest risk of fracture. This means that there are number of potential failure planes and any material anomaly would affect the predictions made. In fact, the implications of Assumption-1 and the above micromechanical aspects have been acknowledged in [24]. When subjected to 3D stress states as required by World-Wide Failure Exercise-II, it has been observed that the predictions made using Mohr approach tend to be on "the non-conservative side". In order to take these into account, Puck [25] resorted to using "weakening factor", an arbitrary parameter to consider the strength weakening caused by these factors. Such an approach is not physically based and finding its appropriate value to effectively

predict failure is not justifiable. To further understand the implications of the Mohr's hypothesis and the micromechanical aspects discussed above, micromechanics based characterisation of UD composites is thus desired.

3. Micromechanical Modelling Approach

In order to perform micromechanical characterisation of composite materials using unit cells approach, a finite element tool named UnitCells© has been made use of in this work. Based on the systematic consideration of symmetries present in idealised fibre-matrix composites, a comprehensive framework of micromechanical analysis using unit cells to predict the effective properties of the composites has been developed over the years [26][27][28][29]. For accurate predictions of effective properties of the composites, it is necessary to apply appropriate boundary conditions to a unit cell model. Since most of the UD composite laminate materials have regular periodic microstructures, the stress and strain distributions in the regular microstructure are also periodic. Therefore, the smallest periodic volume of a regular microstructure can be regarded as a unit cell. The unit cell model with periodic boundary condition represents a large regular microstructure. Considering the periodic geometry and continuous displacement field, periodic boundary conditions for cubic unit cells are defined as follows [28]:

$$\begin{aligned} (u|_{x=b} - u|_{x=-b})|_{y,z} &= 2b\varepsilon_x^0 & (u|_{y=b} - u|_{y=-b})|_{x,z} &= 2b\gamma_{xy}^0 & (u|_{z=b} - u|_{z=-b})|_{x,y} &= 2b\gamma_{xz}^0 \\ (v|_{x=b} - v|_{x=-b})|_{y,z} &= 0 & (v|_{y=b} - v|_{y=-b})|_{x,z} &= 2b\varepsilon_y^0 & (v|_{z=b} - v|_{z=-b})|_{x,y} &= 2b\gamma_{yz}^0 \quad (2) \\ (w|_{x=b} - w|_{x=-b})|_{y,z} &= 0 & (w|_{y=b} - w|_{y=-b})|_{x,z} &= 0 & (w|_{z=b} - w|_{z=-b})|_{x,y} &= 2b\varepsilon_z^0 \end{aligned}$$

where u , v and w are displacements in the unit cell, $2b$ is the dimension of the unit cell and ε_x^0 , ε_y^0 , ε_z^0 , γ_{xy}^0 , γ_{yz}^0 , γ_{xz}^0 are the average strains in the material represented by the unit cell. Unit cells of hexagonal shape are obtained using different translational symmetries, however, their boundary conditions are derived based on the same principle, namely, the displacements on one part of the boundary of the unit cell are related to those on another part, while involving the macroscopic strains in an appropriate manner. With periodic boundary conditions, a model consisting of a number of unit cells should produce identical results as a single unit cell. The periodic boundary conditions for a unit cell require the coordinates of nodes on any pair of opposite faces to be precisely related [27]. For that, the surface mesh of the unit cell has to be created accordingly to satisfy those boundary conditions. Generating a suitable mesh and imposing appropriate boundary conditions within a single piece of software can be an extremely challenging task for composite models. In order to automatise the extremely demanding task of using such a framework in commercial finite element software such as Abaqus, UnitCells© has been developed in the University of Nottingham in order to perform an automated micromechanical analysis of composite materials.

The UnitCells© framework is a highly automated code developed in Python which has been integrated in the Abaqus/CAE platform with a graphical user interface (GUI) similar to that of Abaqus/CAE as shown in figure 4. When using the tool, users can choose their unit cells from the available library of types of unit cells. Abaqus/CAE or its inherent FE pre-processor, Hypermesh, can then be called within the code to generate high-quality meshes and subsequent processing can be done using Abaqus Solver. By using UnitCells©, users have been relieved of the challenging aspects of micromechanical analysis such as generating suitable meshes, imposing appropriate boundary conditions, applying loads, choosing the type of finite elements, submitting the analysis to the Solver and post-processing for the results as they are automated [15].

4. UnitCells FE Analysis Methodology

This section will briefly describe the methodology of using UnitCells© tool to perform finite element micromechanical analysis of composites and hence determine the extent of applying the Mohr

hypothesis to UD composites. The unit cell formulation is the result of an idealisation process and hence it is subjected to the following assumptions or conditions:

- (1) There exist regular irregularities throughout the material: The formulation is capable of accommodating irregular fibre shapes, imperfections such as local debonding, microcracks and voids as long as all these arbitrary irregularities within a unit cell extend throughout the length and the cross-section of the fibres showing a regular pattern. Although such a case may not exist in reality, it provides a useful understanding of the stress distribution within the unit cell.
- (2) The material behaviour is linear elastic: The unit cell formulation has been derived for only linear material behaviour. However, it is capable of being extended to non-linear problems of any material, geometry [27].

The FE method of micromechanical analysis used in this work is relatively straightforward and can be broken down into the following steps. All these steps can be dealt with using appropriate GUIs in a user-friendly, interactive manner.

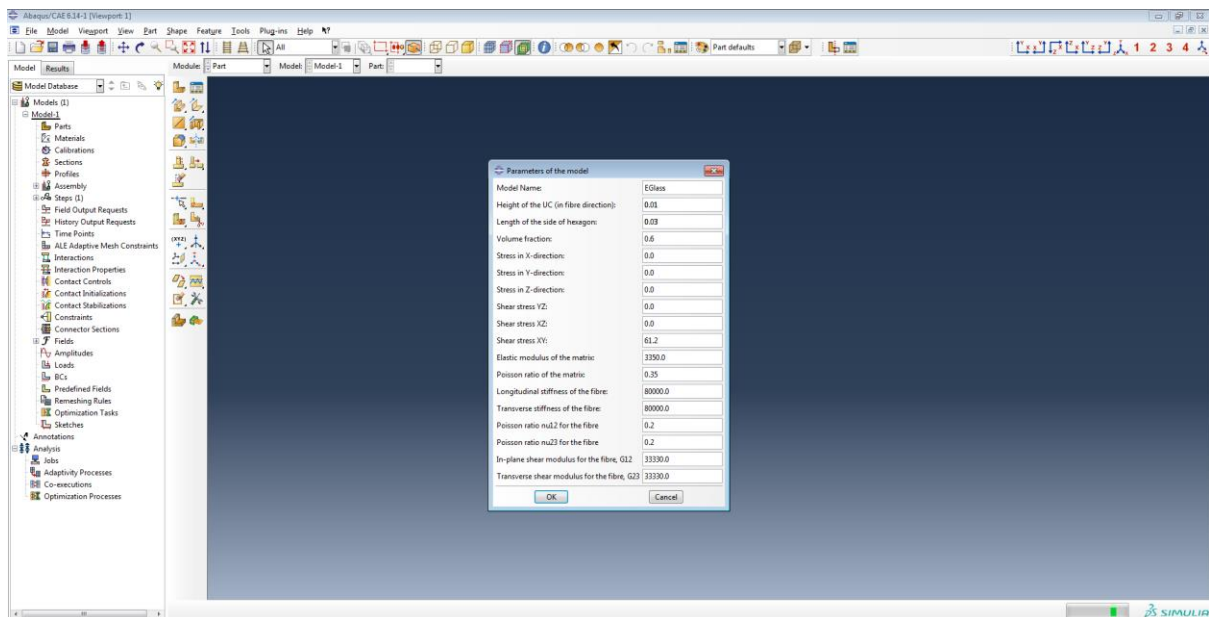

Figure 4. UnitCells© GUI in Abaqus/CAE.

4.1. Selection of an appropriate UC shape

In general, the shape of the unit cell appropriate for an analysis depends on the micro-structure of the composite material studied and the one which can ideally reflect the material structure on a macroscale. For unidirectional fibre-reinforced composites in which fibres are distributed at random over the transverse cross sections, hexagonal packing can be a good reflection of reality and much idealistic than square packing. The reason being, unidirectional (UD) composites are usually transversely isotropic due to the random distribution of fibres over cross sections and hexagonal packing/unit cell is able to preserve this feature of the UD composites.

4.2. Dimensioning of the unit cell

Ideally, the dimensions of the unit cell should be defined as they are in reality. In that case, unit cells are usually at microscopic length scales and the actual numbers used to define the dimensions of the unit cell are often in the scale of microns. A practical issue with Abaqus/CAE is that the numbers used to define the dimensions should fall within a range of 10^{-3} to 10^{+5} [15]. However, users can define the unit system employed in Abaqus like most commercial codes as long as it is consistent. For instance, when using standard ISO units, the dimensions would be in metres, while the input material elastic

moduli and output stresses would be in pascals. Poisson's ratios and strains are dimensionless and hence they cause no problems. For simplicity and easier recognition, millimetres for dimensions and megapascals for stresses and elastic moduli are followed in this work. The specific dimensions of the hexagon unit cell can be the height (h) of the unit cell (in fibre direction) and the length of the side of the hexagon (a) as shown in figure 5.

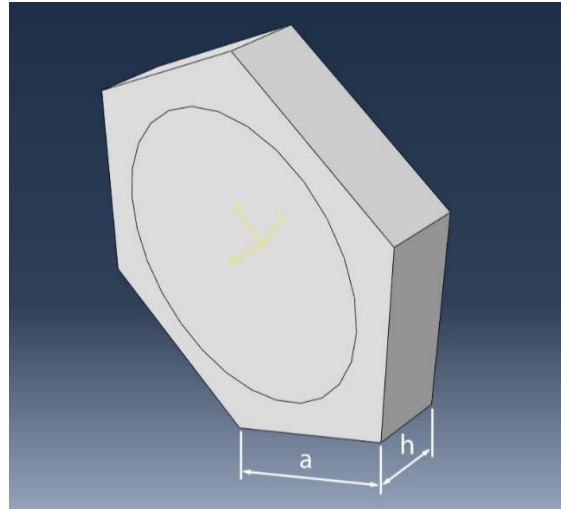

Figure 5. A hexagonal unit cell model

4.3. Choosing the FE element type

The choice of finite element has been 3D brick elements in UnitCells© as they are suitable for much smaller geometry as in this case. Also they support translational degrees of freedom employed in formulating the periodic boundary conditions and automatic mesh generation using Hypermesh. Since there is no gradient of the microscopic stress/strain field in the direction along the fibres in a UD composite, when subjected to uniform macroscopic stresses, a single layer of brick elements in this direction is sufficient to capture the behaviour completely. Further use of layers of elements in this direction is unnecessary as long as the boundary conditions have been imposed correctly.

4.4. Defining mesh density

FE analyses often require reasonable mesh sizes for the numerical convergence considerations. Besides, some extra restrictions apply for hexagonal unit cells. To impose periodic boundary conditions, the corresponding paired faces of the periodic boundary conditions in the hexagon must be related identically [15]. This is usually achieved by copying one tile to another before generating the mesh inside the unit cell between such paired faces. Since this function is not available in Abaqus/CAE, UnitCells© calls Hypermesh as required for mesh generation. The Python script programming facility enables this feature and it can be called within UnitCells© through Abaqus/CAE without user involvement. Although the convergence of effective properties is usually obtained sooner, a higher mesh density is still desired to achieve convergence in the microscopic stress field. For this work, a mesh density of 20 element nodes per side of the hexagon has been used to ensure finer stress distribution.

4.5. Definition of constituent materials

Transversely isotropic glass fibre reinforced epoxy composite material is considered as an example for this analysis. The material properties of the matrix and fibre can be defined in a local coordinate system to account for the material orientations. The specific material properties used for this work are in terms of elastic engineering constants i.e. Young's modulus, Poisson's ratio and shear modulus. A graphical

user interface allows for the definition of each phase of the composite reinforcement and matrix as shown in figure 6. Further the volume fraction of the material can also be entered.

Parameter	Value
Model Name:	EGlass
Height of the UC (in fibre direction):	0.01
Length of the side of hexagon:	0.03
Volume fraction:	0.6
Stress in X-direction:	0.0
Stress in Y-direction:	0.0
Stress in Z-direction:	0.0
Shear stress YZ:	0.0
Shear stress XZ:	0.0
Shear stress XY:	61.2
Elastic modulus of the matrix:	3350.0
Poisson ratio of the matrix:	0.35
Longitudinal stiffness of the fibre:	80000.0
Transverse stiffness of the fibre:	80000.0
Poisson ratio nu12 for the fibre:	0.2
Poisson ratio nu23 for the fibre:	0.2
In-plane shear modulus for the fibre, G12:	33330.0
Transverse shear modulus for the fibre, G23:	33330.0

Figure 6. A unified GUI window for inputting the parameters of the model

4.6. Applying the boundary conditions

Automatically prescribing the periodic displacement boundary conditions has been one of the highlighting features of using the UnitCells© tool. Defining the boundary conditions of unit cells in a micromechanical analysis can be tedious and challenging process even for advanced FE user. This process has been automated in UnitCells© and the appropriate boundary conditions are applied intrinsically for the unit cell geometry considered. Further information on the implementation process can be found in [15].

4.7. Applying the loading

The unit cell formulation enables applying the loading in terms of the six macroscopic stresses σ_x^0 , σ_y^0 , σ_z^0 , τ_{xy}^0 , τ_{yz}^0 , τ_{xz}^0 in any way the user requires either individually or in any combination. The six macroscopic stresses are prescribed individually as six load cases within a single step of analysis using graphical user interface shown in figure 6.

Following the user required inputs such as unit cell dimensions, volume fraction, material properties and loading conditions, the user can simply submit the analysis and the UnitCells© tool automatically invokes other modules including Hypermesh and Abaqus Solver. After post-processing, the output is produced in the form of geometry model which can then be accessed by the user for contour plots of stress field distribution using Visualisation module in Abaqus/CAE.

5. Results and Discussion

In order to ensure obtaining accurate results, sanity check is performed initially by homogenising the unit cell. Although the implementation has been extensively verified for the unit cell used, sanity check will provide confidence over the stress contours obtained at a much later part of the analysis. A simple ‘sanity check’ can be performed by entering the known data values of an isotropic material for both fibre and matrix such that the whole unit cell becomes isotropic. Upon applying the loads, obtaining a uniform stress field throughout the unit cell will qualify the sanity check. One can be assured of a potential error in the code if a colourful contour plot with largely varying values is obtained. Table 1 below lists the constituent material properties of the E-glass/epoxy composite lamina (Fibre: E-glass 21xK43 Gevetex, Matrix: LY556/HT907/DY063 epoxy). By using the resin properties of table 1 for both matrix and fibre in the hexagonal unit cell and applying an arbitrary longitudinal tensile loading of 10 MPa, the input data has been reproduced as the effective properties of the material albeit some numerical noise due to rounding off errors as shown in figure 7. This verified the completeness of the unit cell model and the code used.

Table 1. Material property of the matrix and fibre (taken from [30])

Matrix: LY556/HT907/DY063 epoxy		Fibre: E-glass 21xK43 Gevetex		
E_m (GPa)	ν_m (–)	E_f (GPa)	ν_f (–)	G_f (GPa)
3.35	0.35	80	0.2	33.33

With the confidence in unit cell code established through sanity check, the step-by-step FE methodology described in section 4 has been followed. Using the constituent material properties listed in table 1 and a fibre volume fraction of 62%, hexagonal unit cell was used to calculate the effective properties of the unidirectional lamina of interest. The values computed have been provided in table 2 and it can be seen that there exists a good correlation between both the model predictions and the experimental results.

Table 2. Effective material properties of the unidirectional composite lamina.

	E_1 (GPa)	E_2 (GPa)	ν_{12} (–)	G_{12} (GPa)	ν_{23} (–)
UnitCells©	50.87	12.65	0.249	4.63	0.396
Experimental [30]	53.48	17.7	0.278	5.83	0.4

Following a double validation using sanity check and further experimental validation of the effective property values computed using simulations, further analyses have been performed for varying load ratios listed in table 3 for the same input material parameters. In order to understand the stress distribution in the composite unit cell and the corresponding stress values in the matrix, two sets of stress plots for each loading case are presented (see figure 8). First parts denoted (a) correspond to the composite unit cell and (b) to the isolated matrix.

Having performed the sanity checks and experimental validation of effective properties predicted using the unit cell model, the results of the unit cell analysis are expected to ideally reflect the stress distribution within the composite lamina in the macro scale. For the uniaxial and biaxial transverse loading cases considered in table 3, it can be seen that the stress concentration is present in the fibre region (see figure 8: Ia, IIa, IIIa, IVa, Va). This might indicate the crushing failure of fibres. However, experimental evidence shows that the composite lamina will be subjected to matrix failure since the matrix is much softer than the fibres. Hence, the stress concentrations in the matrix alone have been focussed for understanding the possibility of failure as shown in parts Ib, IIb, IIIb, IVb, Vb of the figure 8. Having only implemented linear elastic analysis in this model, these stress concentrations could be indicative of the first failure locations. However, the composites might undergo marginal non-linear behaviour immediately preceding the final fracture and hence these stress concentrations may not truly reflect the actual failure surface. Hence further understanding of the non-linear behaviour may be required to fully comment on the applicability of Mohr’s hypothesis.

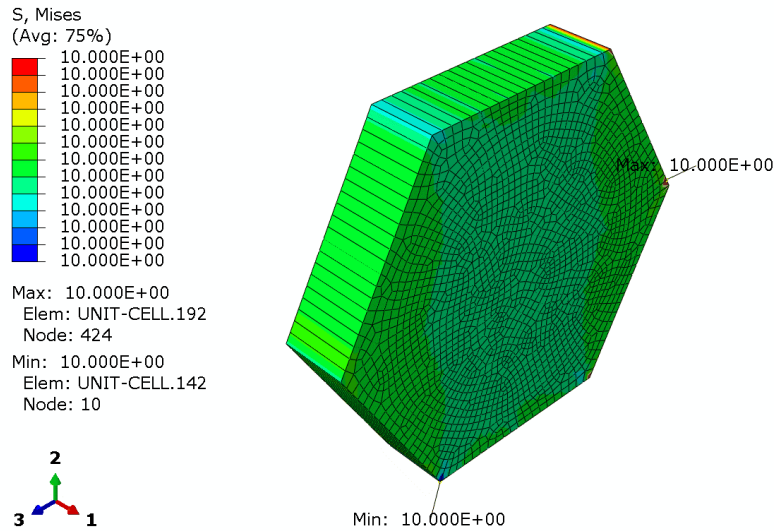
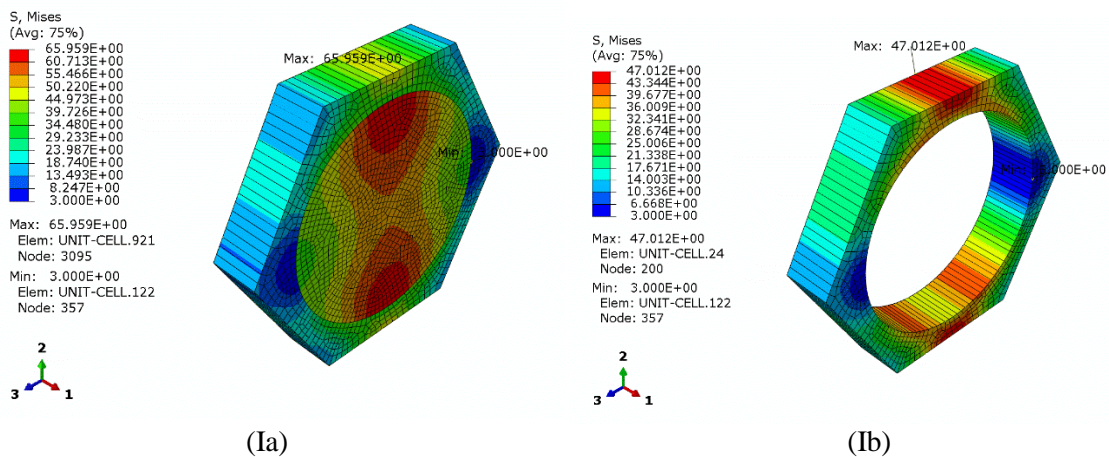

Figure 7. Stress distribution in a homogenised unit cell for Sanity Check

Table 3. Data for biaxial failure stresses of 0° unidirectional lamina under combined transverse and shear loading (σ_y versus τ_{xy}). (selected from [30])

Load case	Transverse stress - σ_y (MPa)	Shear stress - τ_{xy} (MPa)
I	40	0
II	18	51.3
III	-132.3	0
IV	-122	54.6
V	0	61.2

In a similar way to the effective stiffness calculations performed, the model can be used to perform strength analysis by subjecting the model to increasing values of stress. The corresponding stress components obtained in the local material coordinates of the model can then be used in an appropriate failure criterion to predict the strength. This approach may be applicable until the occurrence of localisation in the complete failure mechanism. Post the onset of such localised deformation, non-linearity has to be considered and this makes the model no longer periodic. As a result, the periodic boundary conditions used in this model need to be redefined. This will be considered as a future course of action, nevertheless it is challenging. UnitCells© tool can also be extended for the non-linear and strength analysis by incorporating a UMAT subroutine.



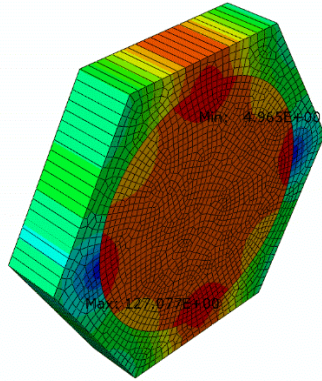
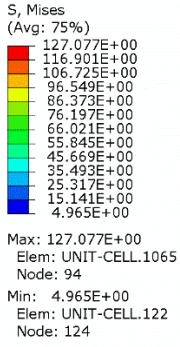

(IIa)

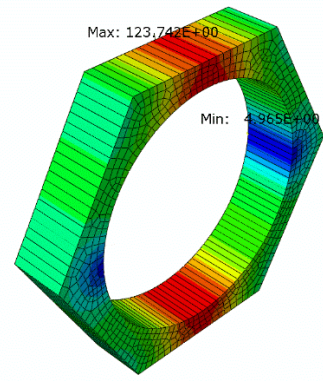
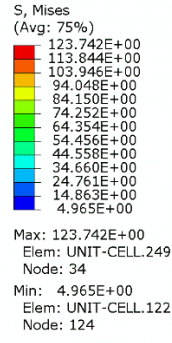

(IIb)

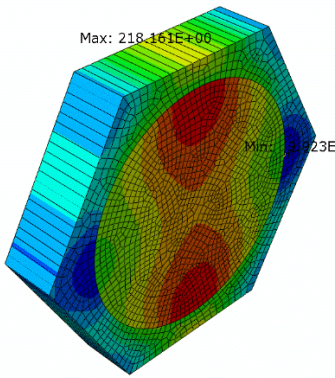
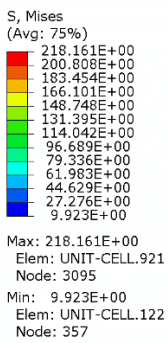

(IIIa)

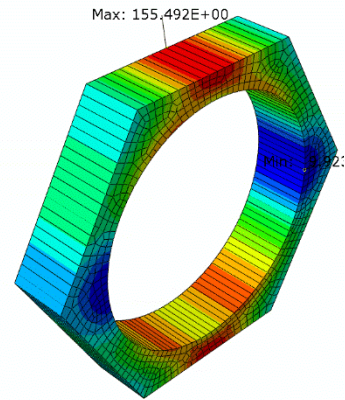
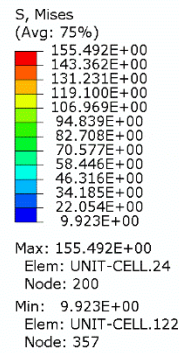

(IIIb)

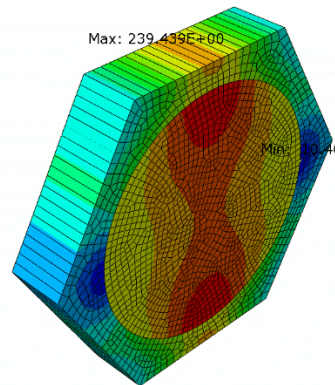
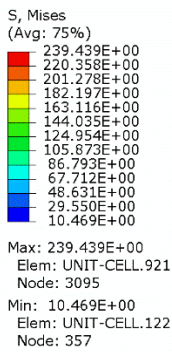

(IVa)

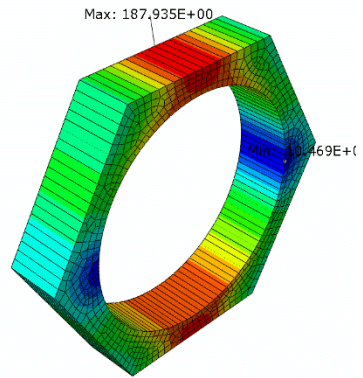
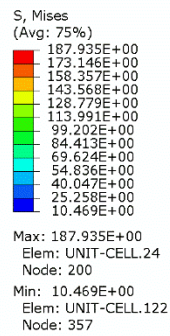

(IVb)

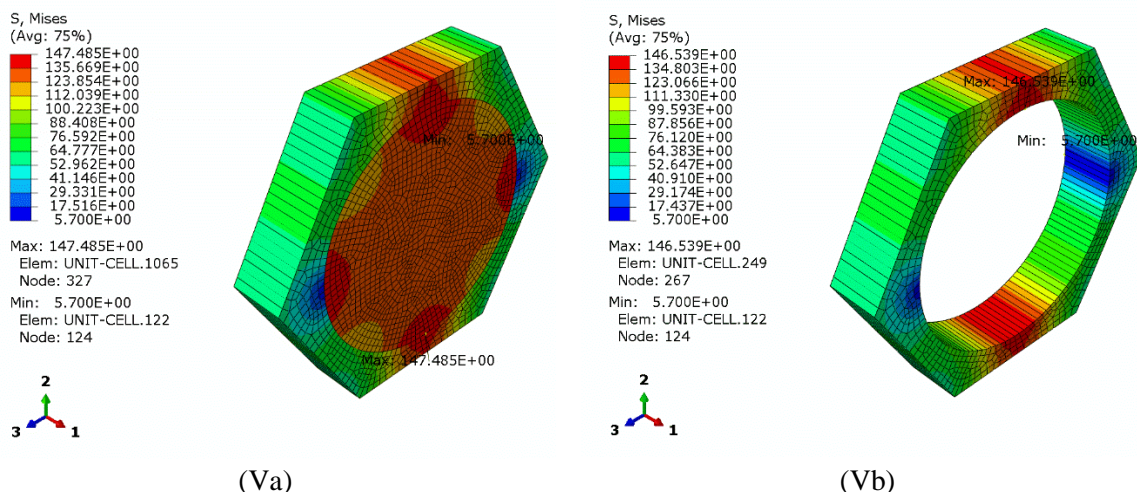

Figure 8. von Mises stress contour plots for five load cases in: (a) composite unit cell, (b) isolated matrix.

6. Conclusion

The applicability of Mohr-Coulomb failure hypothesis for composite materials has been re-evaluated in this work. Following the extensive review of evolution of the hypothesis and its current performance in predicting the failure of composite laminates, it was understood that the concept of principal stresses utilised in constructing 3D Mohr circle and the subsequent assumption that the outermost circle represents the critical state of failure, led to overlooking certain micromechanical aspects of failure in composites. Thus, it was found that the concept of principal stresses is not applicable in composites to completely define failure as in isotropic materials. Further, the necessity to understand the micromechanical viewpoint of failure is identified.

Micromechanical characterisation of UD composites using UnitCells was attempted and it was found that it could be useful in predicting initial failure using stress concentrations observed in the matrix. However, non-linear behaviour has to be considered in order to fully make use of the UnitCells predictions to comment on the applicability of Mohr's failure hypothesis. With the future areas of work identified, this paper has provided a possible direction to improve the failure criterion of composites based on Mohr's hypothesis and hence effectively design composite structures.

Acknowledgements

The first author would like to thank the University of Nottingham's International Office for providing the funding required to undertake this research in the name of Developing Solutions Scholarship.

References

- [1] IPCC, (2014). Synthesis Report. Climate Change 2014. Geneva, Switzerland: Intergovernmental Panel on Climate Change, p.151.
- [2] Advisory Council for Aeronautical Research in Europe, (2011). *Roadmap to a Single European Transport Area – Towards a competitive and resource efficient transport system*. Brussels, Belgium: European Commission.
- [3] Hale, J. (2006). Boeing 787 from the Ground Up. *Aero*, [online] (24), p.18. Available at: http://www.boeing.com/commercial/aeromagazine/articles/qtr_4_06/AERO_Q406.pdf [Accessed 03 Sep. 2016].
- [4] Paris, F. (2001). *A study of failure criteria of fibrous composite materials*. Tech. Rep. NASA/CR-2001-210661. Hampton, Virginia: National Aeronautics and Space Agency.
- [5] Hinton, M., Kaddour, A. and Soden, P. (2004). *Failure criteria in fibre reinforced polymer composites*. Amsterdam: Elsevier.

- [6] Kaddour, A., Hinton, M. (2013) Maturity of 3D failure criteria for fibre-reinforced composites: Comparison between theories and experiments: Part B of WWFE-II. *Journal of Composite Materials*, 47(6-7), 925-966.
- [7] Tsai, S. and Wu, E. (1971). A General Theory of Strength for Anisotropic Materials. *Journal of Composite Materials*, 5(1), pp.58-80.
- [8] Puck, A., Schürmann, H. (1998). Failure analysis of FRP laminates by means of physically based phenomenological models. *Composites Science and Technology*, 58(7), pp.1045-1067.
- [9] Mohr, O. (1900) Welche Umstände Bedingen die Elastizitätsgrenze und den Bruch eines Materials. *Zeitschrift des Vereines Deutscher Ingenieure*, 44, 1524 – 1530 and 1572-1577 [in German].
- [10] Hashin, Z. (1980). Failure Criteria for Unidirectional Fiber Composites. *Journal of Applied Mechanics*, 47(2), p.329-334.
- [11] Puck, A. (1992). A failure criterion shows the direction. *Kunst- stoffe, German Plastics*, 82, pp.29-32. (German text pp. 607-610).
- [12] Hinton, M. and Kaddour, A. (2012). The background to the Second World-Wide Failure Exercise. *Journal of Composite Materials*, 46(19-20), pp.2283-2294.
- [13] Pinho, S., Darvizeh, R., Robinson, P., Schuecker, C. and Camanho, P. (2012). Material and structural response of polymer-matrix fibre-reinforced composites. *Journal of Composite Materials*, 46(19-20), pp.2313-2341.
- [14] Hashin, Z. (1983). Analysis of Composite Materials—A Survey. *Journal of Applied Mechanics*, 50(3), p.481.
- [15] Li, S., Jeanmeure, L. and Pan, Q. (2015). A composite material characterisation tool: UnitCells. *Journal of Engineering Mathematics*, 95(1), pp.279-293.
- [16] Chamis, C. and Sendeckyj, G. (1968). Critique on Theories Predicting Thermoelastic Properties of Fibrous Composites. *Journal of Composite Materials*, 2(3), pp.332-358.
- [17] Coulomb, C. A. (1773). Sur une Application des Regles de Maximis et Minimis a quelques Problemes de Statique, relatifs a l'Architecture. In *Memories de Mathematique et de Physique. Academic Royal des Sciences par divers sans*, 7, 343 - 382.
- [18] Timoshenko, S. (1953). *History of strength of materials*. New York: McGraw-Hill.
- [19] Nádai, A. (1950). *Theory of flow and fracture of solids*. New York: McGraw-Hill.
- [20] Paul, B. (1961). A Modification of the Coulomb-Mohr Theory of Fracture. *Journal of Applied Mechanics*, 28(2), p.259-268.
- [21] Mohr, O. (1882). Ueber die Darstellung des Spannungszustandes und des Deformationszustandes eines Korperelementes und uber die Anwendung derselben in der Festigkeitslehre. *Civilingenieur*, 28, pp.113-156.
- [22] Cauchy, A. (1823). Recherches sur l'equilibre et le mouvement interieur des corps solides ou fluides, elastiques ou non elastiques. *Bulletin de la Société Philomathique de Paris*, p.9.
- [23] Culmann, K. (1875). *Die graphische Statik*. Zürich: Meyer & Zeller (A. Reimann).
- [24] Deuschle, H. and Kroplin, B. (2012). Finite element implementation of Puck's failure theory for fibre-reinforced composites under three-dimensional stress. *Journal of Composite Materials*, 46(19-20), pp.2485-2513.
- [25] Deuschle, H. and Puck, A. (2013). Application of the Puck failure theory for fibre-reinforced composites under three-dimensional stress: Comparison with experimental results. *Journal of Composite Materials*, 47(6-7), pp.827-846.
- [26] Li, S. (1999). On the unit cell for micromechanical analysis of fibre-reinforced composites. *Proceedings of the Royal Society A: Mathematical, Physical and Engineering Sciences*, 455(1983), pp.815-838.
- [27] Li, S. (2001). General unit cells for micromechanical analyses of unidirectional composites. *Composites Part A: Applied Science and Manufacturing*, 32(6), pp.815-826.
- [28] Li, S. (2008). Boundary conditions for unit cells from periodic microstructures and their implications. *Composites Science and Technology*, 68(9), pp.1962-1974.
- [29] Li, S. (2011). On the nature of periodic traction boundary conditions in micromechanical FE analyses of unit cells. *IMA Journal of Applied Mathematics*, 77(4), pp.441-450.
- [30] Soden, P. (1998). Lamina properties, lay-up configurations and loading conditions for a range of fibre-reinforced composite laminates. *Composites Science and Technology*, 58(7), pp.1011-1022.