

Running head: DEVELOPING A PHOTOVOLTAIC POWER PLANT

1

Developing a 1-Megawatt Photovoltaic Power Plant for Liberty University

Andrew Knudsen

A Senior Thesis submitted in partial fulfillment
of the requirements for graduation
in the Honors Program
Liberty University
Spring 2018

Acceptance of Senior Honors Thesis

This Senior Honors Thesis is accepted in partial fulfillment of the requirements for graduation from the Honors Program of Liberty University.

Jung-Uk Lim, Ph.D.
Thesis Chair

John Vadnal, Ph.D.
Committee Member

Edward Moore, Ph.D.
Committee Member

David Schweitzer, Ph.D.
Assistant Honors Director

Date

Abstract

A photovoltaic power plant with a generation capacity of 1-megawatt is designed for Liberty University. Liberty University's location and size are stated to provide context for the design. Design choices are presented, first with general information that is applicable to any photovoltaic plant design, then with significant factors that impact this design. Specific models of solar panels and inverters are selected after the necessary classifications are determined. The final design has 2,880 solar panels with a fixed angle 30° above the horizon, has two central inverters, and takes up 2.57 acres. Future research is suggested for finances as well as expected technological advances.

Developing a 1-Megawatt Photovoltaic Power Plant for Liberty University

Since its inception, photovoltaic power generation has been a growing source of excitement for those who must purchase power and for those who imagine a world where pollution is minimized. While many have doubted whether it would become a viable technology, recent history has indicated that photovoltaic power generation will continue to improve through reductions in hardware costs and increases in efficiency. Even now, photovoltaic power is worthwhile in places with unreliable or very expensive power that have adequate exposure to the solar resource. Based on the trend of increasing worldwide photovoltaic power generation capacity, the amount and importance of energy generated from photovoltaic panels is likely to continue to rise.

Parties Considering Solar Power

In this environment of improving photovoltaic technology and fears over rising fuel costs, many different parties are considering installation of photovoltaic panels on their property to meet some or all of their energy needs. According to Masters (2013), many home-owners are finding that the payback period for solar power is rapidly decreasing so that the initially high cost of solar is becoming increasingly palatable. The residential rates of energy are usually the highest, so offsetting a little bit of energy from a utility has obvious benefits.

Organizations that would consider mid-sized photovoltaic generation facilities are classified as commercial. Masters (2013) explains that these organizations face commercial rates for energy, which usually have a lower base price than the residential rates, but which include a factor for the peak power that the organization uses during a

pay period. If the peak power usage is much higher than the usual power usage by the organization, this will tend to result in the organization paying much higher rates for the power than if the peak power usage is closer to the organization's average demand for power. In this situation, solar power is doubly effective because it can be generated during the daytime hours when power usage reaches its peak for many organizations. Although peak power usage is often in the later afternoon which is after solar power's typical peak power generation at the solar noon, solar power can still reduce the commercial organization's demand for power during its peak power usage time period.

Commercial organizations include mid- to large-sized businesses, government entities, large farms, and educational institutions. These organizations consider photovoltaic power generation for the long-term savings, but also because of the positive attention which they receive for using power that has little negative effect on the environment and does not consume resources that could theoretically run out. Even a smaller installation of photovoltaic panels often gives these organizations enough media attention to offset any costs without even considering additional savings.

The last type of party that could consider photovoltaic power generation are utilities. For photovoltaic power generation to be economical for utilities, Masters (2013) argues that it must reach a low cost because it is competing with the actual cost of generation of the other types of power rather than the retail or commercial price that a customer faces. Additionally, utility-scale power generation plants require the most capital investment, so the risk tolerance is often lower. Because photovoltaic power generation technology is still developing, the involved components' long-term durability

is not as certain, so utilities may be hesitant to install them until they have proved their durability and effectiveness for long enough to ensure that they will be an economically prudent choice.

Parties in the residential, commercial, and utility categories do not make decisions such as purchasing photovoltaic panels in a political vacuum. According to Masters (2013), governments today play a major role in incentivizing activities such as installing photovoltaic panels. In many developed nations, there are tax benefits for installing renewable energy generation capacity. In the United States, this could include benefits at the national, state, and local levels. While not every party can directly take advantage of these tax benefits, almost all of them can take advantage of the benefits indirectly through the use of power purchase agreements, where a party that can use the tax benefits owns the photovoltaic panels and sells the generated power to the party that is unable to use the tax benefits but can use power at a reduced price.

One organization that could benefit from considering a photovoltaic power plant is Liberty University, an educational institution of higher learning located in Lynchburg, Virginia. Romaniuk (2018) states that it has around 15,000 residential students. Liberty University purchases power from the grid from the Appalachian Power Company, a subsidiary of American Electric Power. Liberty University owns 6,500 acres of land, so using property may have a smaller opportunity cost than it would for an organization surrounded by expensive or very desirable land. While Liberty University is not located in the ideal location for solar power generation because of the moderate amount of clear, sunny skies it receives, as can be seen in Table 1, it still provides an interesting design

Table 1

Lynchburg Sky Conditions by Month

Month	Clear Days	Partly Cloudy Days	Cloudy Days
January	9	7	15
February	8	7	13
March	9	9	13
April	9	9	12
May	8	10	13
June	8	12	10
July	8	12	11
August	9	11	11
September	10	9	11
October	13	7	11
November	10	7	13
December	10	7	14
Total	111	107	147
% of Total	30.4	29.3	40.3

Note. While Lynchburg receives many clear days throughout the year, it receives even more cloudy days. Data for table retrieved from the “The History of Solar” by the U.S. Department of Commerce, National Oceanic and Atmospheric Administration (n.d.), <https://www1.ncdc.noaa.gov/pub/data/ccd-data/CCD-2015.pdf>

situation which could show that photovoltaic power generation is feasible for many other organizations throughout the world, even if they are not in the sunniest regions.

Relevant Solar Projects

In the United States, solar power generation is not ubiquitous, but it is also not uncommon. While home-owners have been considering roof installations for many years, the Solar Energy Industries Association (2017) shows that many large solar projects around the world have been planned and completed in the last five years. Some solar projects relevant to Liberty University are included below. First, to show that universities can benefit from owning a photovoltaic power generation facility, some projects from other universities are included. Second, to show that solar power is a viable option in Virginia, projects from Virginia are included. As an example, a simple schematic of a solar power system for a university is included in Figure 1.

University of Illinois

Romaniuk (2018) states that the University of Illinois at Urbana-Champaign, Illinois, has over 40,000 enrolled students and sits on 1,783 acres. The university completed a 4.68 MW solar farm on 20.8 acres of land in 2015. The array consists of 1,008 strings of up to 19 modules each, which adds up to a total of 18,867 modules. These modules are the typical crystalline silicon modules. The university believes that the panels will continue to produce power for 40 years and that the panels will only meet around 2% of the university's energy demand (University of Illinois at Urbana Champaign Facilities and Services, 2015).

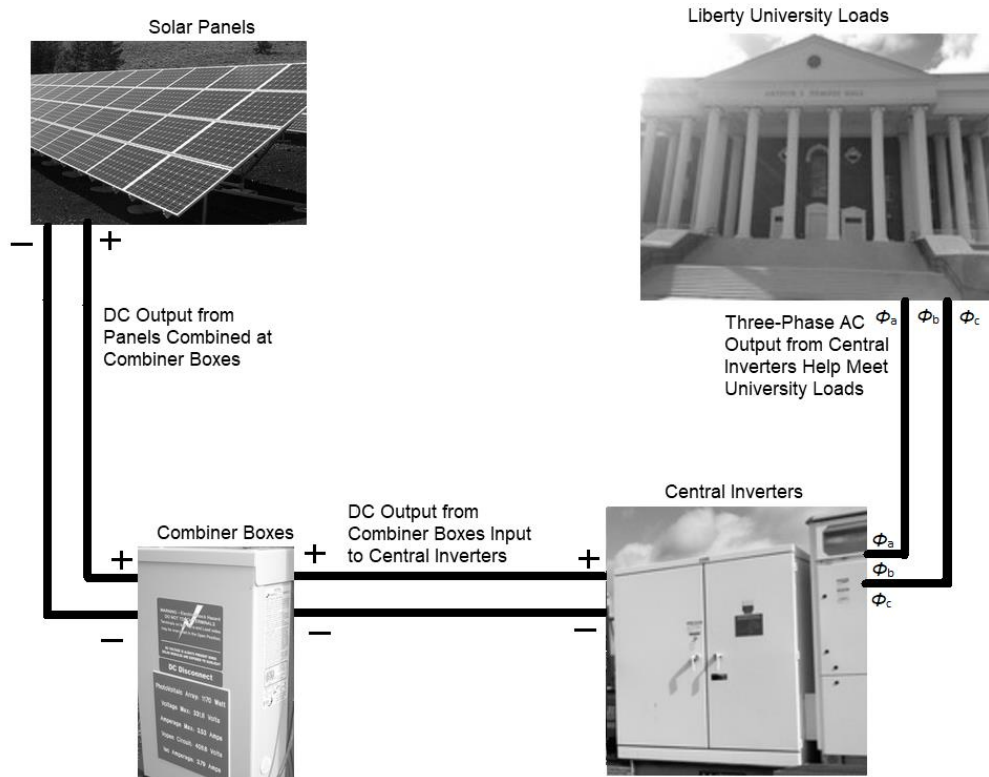

Figure 1. Schematic of a photovoltaic power system with key components. The image of photovoltaic panels is adapted from *Solar Panel Array, Power, Sun*, by Skeeze (2011), <https://pixabay.com/en/solar-panel-array-power-sun-1591350/>. Used under CC0 1.0 Universal License: <https://creativecommons.org/publicdomain/zero/1.0/>. The image of a combiner box is adapted from *Combiner box*, by Cgulyas (2008), <https://pixabay.com/en/solar-panel-array-power-sun-1591350/Cgulyas2002>. Used under Attribution-NonCommercial 2.0 Generic License: <https://creativecommons.org/licenses/by-nc/2.0/>. The image of an inverter is adapted from the government work, *An inverter on a 100 MW solar site*, by D. Huston-Bursaw (2017), <https://www.flickr.com/photos/departmentofenergy/35941357930>. The image of Liberty University was taken by the author.

Eastern Mennonite University

Eastern Mennonite University is a smaller Christian college in Harrisonburg, Virginia. Romaniuk (2018) indicates that it has over 1,700 students overall. According to Eastern Mennonite University (n.d.), it installed an array of solar panels in 2010. This was a smaller project, with a capacity of only 104 kW, but it is evidence that colleges near Liberty University are considering solar power generation. When this project was completed in 2010, it was the largest solar power plant in Virginia, but it has now been surpassed by several others.

University of Virginia

According to Romaniuk (2018), the University of Virginia is located on over 1,100 acres in Charlottesville, Virginia, and has over 23,000 students. Kelly (2017) states that in 2016 and 2017, the university agreed to purchase the output from two solar power generation facilities that have a capacity of 32 MW. These facilities together cover 280 acres of land and will meet about 21% of the university's projected energy demand. Both of these facilities are expected to be completed before 2019.

University at Buffalo

Romaniuk (2018) states that the University at Buffalo has a campus of 1,350 acres and over 30,000 students enrolled. According to Hill (n.d.), the university completed a 750 kW project on around 4 acres of land in 2012. The university views the solar project as a way for the university to educate children about solar power and the benefits that renewable energy can bring.

Colorado State University

Romaniuk (2018) writes that Colorado State University has a campus of 586 acres in Fort Collins, Colorado, and over 33,000 students. According to Colorado State University (n.d.), the university completed a two-phase solar project which has a DC capacity of 5.3 MW in 2010. This project covers a total of 30 acres and is expected to meet over 30% of the university's energy demand.

Princeton University

According to Romaniuk (2018), Princeton University is located in Princeton, New Jersey, has a campus of 600 acres, and has 8,181 enrolled students. The Princeton University Office of Sustainability (n.d.) states that the university completed a 4.5 MW project on 27 acres of land in 2012. The university claims that it has one of the largest solar arrays of any educational institution.

Bedford, Virginia

A 3 MW solar farm has been constructed in Bedford, Virginia, which is around 30 miles east of Lynchburg, Virginia. Sides (2018) claims that this project was initiated in 2016 and began operating in December 2017. Smith (2016) states that the project is located on Bedford city land and that the energy it generates will be sold to the city for 6.19 cents per kWh. This makes the venture beneficial to the city because, according to the U.S. Energy Information Administration (2017b), the city will sell the energy to residential customers at a rate of 11.1 cents per kWh. The solar farm was also recognized as a good use of land that was undesirable because it is located next to a landfill.

Rationale for Creating a Design for Liberty University

With the evidence of the numerous other solar projects on university campuses and in Virginia, it seems like it would be reasonable to think that Liberty University could potentially benefit from a photovoltaic power generation plant. Expected savings would come through paying less mark-up to the utility and through less transmission line losses that the utility must charge to the end customer. A potential design for Liberty University will be presented that is specific to the university, but could also be theoretically useful to a more generalized audience for creating a potential design for their circumstances.

Scope

The purpose of this paper is to demonstrate an example of the design process that could take place for engineers who are planning to create a solar power plant. A specific situation is chosen to use as an example, but efforts are taken to show what sets apart the example situation from other situations in order to increase the usefulness of this paper to anyone designing a solar power plant. An attempt is made to show why each element of the design is chosen as opposed to others in order to clarify that process for the reader.

While universities represent some of the demand for solar power plants, Perea et al. (2017) states that they represent a small fraction of the entities considering ways to lessen their reliance on the grid and save money through installing solar power plants. Homeowners may want to install solar power panels for long-term cost savings. Industrial companies are another example of a party that may want to install larger power generation facilities in order to power factories. Power companies may need to increase

their capacity in a way that fits into possible future government regulations. Some of the rationale in this paper defending the choice of fuel and other design specifications could be applied to the other situations as well.

Method

This paper provides a conceptual background for building new power plants and then narrows down to an engineering feasibility and design process for Liberty University. A similar process was completed by Berwal, Kumar, Kumari, Kumar, and Haleem in 2017. Some of the key steps in this process are analyzing the location, making design choices, determining the system's layout, and developing a maintenance schedule. Each of these steps are utilized as a part of the method for this paper. Before stepping forward to this process, it is helpful to view an overall system diagram. Because of this, a block diagram of a photovoltaic power plant is included as Figure 2 to show how several of the components fit together and to show how the power flows in the system. Many of the components and the layout of the system are described and explained throughout the rest of the paper.

Location Analysis

The first step of the process is to consider relevant features of the university's location. These relevant features include weather, solar radiation received, and land available. The local price of power also helps to determine whether the project will be worthwhile. The surrounding infrastructure in place for power can also be accounted for when finding if new power lines are needed or even if the system can be set up in a grid-connected way.

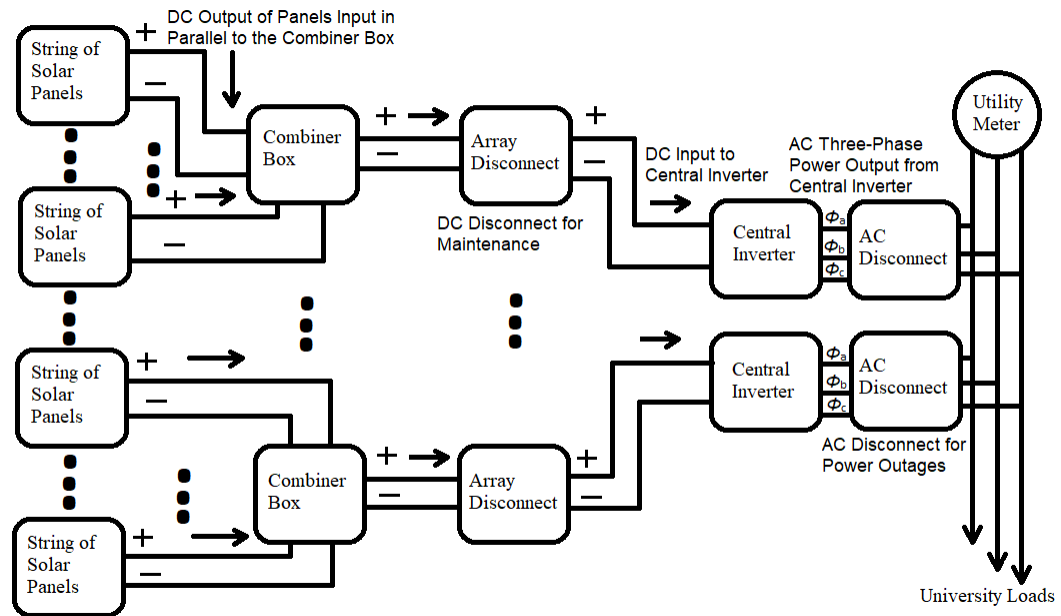

Figure 2. Block diagram of the system which will be designed. The figure has been logically extended based on the much smaller system presented by Masters (2013, p. 318).

Design Choices

After the important characteristics of Liberty University's location are understood, system characteristics, layout, and the maintenance schedule for the power plant can be selected. This paper initially considers several fuel types that could be used for a new power plant before defending the choice to design a photovoltaic power plant. After this, the most important choices are the solar panels and inverters that will be used in the system. The layout is developed based on the electrical values of the solar panels and inverters. According to Tanțău, Regneală, and Coraș (2014), the layout of a solar power plant is an important contributor to the overall efficiency of the system, so this step

will be taken carefully. Finally, the maintenance required is specified based on the manufacturer's suggestion.

Main Argument

The price of electric power is one of the costs that most organizations in developed nations face. However, Corneli and Kihm (2016) state that the market for electric power tends to result in a natural monopoly for one company. This means that there is often little competition from which to buy power, so organizations have few options but to buy from the local utility. One choice that has been made in the past by universities is the choice to generate power by the organization for the organization. This choice is attractive to large, traditional universities and continues to grow in popularity according to Gild (2013). This forces the utility to compete with another price and could result in real cost savings.

Power Generation Fuel Options

Electric power has become a significant resource for civilized societies. It facilitates other technology advances and increases the quality of life for those who have access to it. Because of this, power generation is clearly an important practice that is deserving of study and analysis. Hausman and Neufeld (1990) state that centralized power generation and distribution began in 1882 with Edison's Pearl Street Station in Manhattan. This station lit only a thousand lights within one square mile, but it signaled the rise of the current power grid. Since then, various fuels have been used as the means to produce power. Key fuels from the past include coal, oil, and water power. Some of these resources have the theoretical possibility of being entirely used up if all of the

earth's reserves have been discovered and depleted. Additionally, power generation with these fuels often releases pollutants into the atmosphere, so now governments and organizations are strongly encouraging the use of renewable, clean sources of energy.

Traditional fuels. New power plants are likely to continue to be constructed for fuels such as coal, oil, and natural gas into the foreseeable future. According to Marcy (2018), more than half of new utility-scale capacity in 2017 utilizes non-renewable fuels. This means that the renewable options will need to continue to improve to be able to compete with these solid, traditional options.

Nuclear. Xiao, Liu, and Feldman (2017) state that while nuclear power generation has many benefits for utilities, its drawbacks include a small chance of extreme catastrophe and the associated public reluctance to embrace the technology. It is also not feasible for most organizations to generate power in this way because of the large-scale and large input costs associated with nuclear power. According to the U.S. Energy Information Administration (2017a), the smallest nuclear power plant in the United States still has a capacity of 582 MW. With continued advances in nuclear power technology, it could remain a key competitor in the general power generation field, but not for most organizations looking to generate their own power and not with continued societal ambivalence toward the technology.

Wind. Wind power generation has been growing rapidly throughout the United States where there is an abundance of wind available. Lu, McElroy, and Kiviluoma (2009) state that the wind resource within the borders of the country has the potential to supply 16 times the country's current demand for electricity. Masters (2013) shows how

the length of windmill blades has been increasing and how that allows each windmill to produce more electricity than before. Windmills can be difficult to use, though, because they have a bigger environmental impact than expected, because they are often described as unpleasing aesthetically, and because they can be unpredictable in their generation capacity schedule.

Non-photovoltaic solar. Concentrated solar power is the generation of power from several mirrors concentrating sunlight on one point to heat up that point and produce power through traditional steam generation. This method of power generation is renewable and could have many benefits, but, according to Ho (2016), one drawback is the environmental impact that birds sometimes face as they fly through these generation facilities, although some say this effect is overstated.

Photovoltaic solar. Photovoltaic power generation is one option that has been growing in popularity throughout the world. In the last five years, several large utility-scale photovoltaic power plants have been begun operating. Additionally, decreasing manufacturing costs have made solar panels more affordable for everyone from residential homeowners to large commercial factories and this trend could continue.

Relevant Types of Organizations

Organizations that produce power can be categorized into three different groups. Each of these groups have different interests and needs, so they can end up making different decisions about the type of power generation that they use.

Residential. Goodrich, James, and Woodhouse (2012) state that residential power has a capacity up to 10 KW. This is small, but a small power generator can make sense

for people that live in high energy price areas or who want the security of having a source of energy that is not on the grid. Photovoltaic power is one of the key options for this set of stakeholders.

Commercial. Goodrich et al. (2012) indicate that commercial power plants have a capacity up to several MW. This means that they can be producing a large amount of electricity and offsetting considerable costs. At this scale, most fuels, notably excluding nuclear, can be considered as an option.

Utility. Romero-Cadaval, Francois, Malinowski, and Zhong (2015) state that utility-scale power plants can have a capacity of thousands of megawatts and photovoltaic power plants in particular have reached capacities of at least 250 MW. Utilities have an economy of scale and the demand for a high amount of whatever fuel is being consumed, so they come with their own set of constraints that are different from the residential or commercial power plants. Utilities are also often risk-averse and tend to opt for a traditional option that has worked well in the past.

Choice for Liberty University

Universities have power plants for different reasons. According to Gild (2013), some older universities have power plants because the universities are older than the power grid and they needed to generate power before they could purchase it. Many universities want to save money by building a power plant. Others want to increase their real and perceived environmental friendliness by opening a power plant using a renewable fuel to reduce dependence on the coal or oil power plants often utilized by utilities.

Liberty University is a moderately sized university located in Lynchburg, Virginia. This area receives a moderate amount of solar irradiance and has relatively low electricity costs. According to unpublished Liberty University power data from 2017, a higher portion of its demand is during the typical hours of classes, which is from around 8 am to 5 pm.

Weather details. According to Marion and Wilcox (1994), on a flat plane, Lynchburg receives 1604.9 kWh/m² of solar radiation per year, or an average of 4.4 hours per day. On a plane pointed south at the angle of Lynchburg's latitude of 37.41°, this increases to 1834.7 kWh/m² of solar radiation per year and 5.03 hours per day, as shown in Table 2. This is based both on its latitude, as locations closer to the equator will receive more solar radiation, and on the proportion of days that are cloudy, as clear skies will increase the solar radiation received by a location.

Property available. Romaniuk (2018) states that Liberty University is known to own over 6,500 acres of land. This means the university would be able to use some of that land for a power plant at a low opportunity cost. Right now, much of the land is covered by trees, so they would need to be cleared away before the land would be useful for a power plant.

Price of energy. Liberty University pays the commercial rate for electricity. According to the U.S. Energy Information Administration (2017b), the overall average rate is about 8.43 cents per kWh in Virginia, which is below the national average. This means that any power generation plant would need to compete with a fair price for electricity.

Table 2

Monthly Solar Radiation Received in Lynchburg

Month	Flat Collector (kWh/m ² /day)	Collector at 37.41° (kWh/m ² /day)
January	2.4	3.9
February	3.2	4.6
March	4.3	5.3
April	5.4	5.7
May	6.0	5.7
June	6.5	5.8
July	6.2	5.7
August	5.6	5.7
September	4.7	5.3
October	3.7	5.0
November	2.6	4.0
December	2.1	3.6

Note. The flat collector performs better than the collector at Lynchburg's latitude during the months of May, June, and July because the sun is higher in the sky during those months. This means that the sun's radiation is closer to normal to the flat collector during those months. Table adapted from *Solar Radiation Data Manual for Flat-Plane and Concentrating Collectors* by Marion and Wilcox (1994), Golden, CO: National Renewable Energy Laboratory.

Selection. The fuel for Liberty University's situation can be selected from the factors given so far. While a fuel such as coal or oil could be used, the desire to reduce pollution makes them less attractive. The generation capacity of a potential nuclear power station would be too large for the university's load. Liberty is a commercial customer of electricity and so would need only a moderately sized facility to offset current power usage from the grid. The renewable resources that have been growing in popularity are solar and wind. Wind is considered a less viable option for Lynchburg because of wind turbines' detriment to the environment and because, according to Edelstein, Walcek, Cox, and Davis (2003), wind power is feasible only if average wind speeds exceed a minimum of 15.84 km/h. This is greater than the average wind speed for any month in Lynchburg, as is demonstrated in Table 3. Much of the university's power demand comes during the day, so solar power's peak in the afternoon would help to reduce the peak demand of the university from the grid. Lynchburg receives enough solar irradiation for a significant amount of power to be generated from solar arrays. Finally, Liberty has enough property available to be able to set aside many acres for a solar power generation facility, if that is found to be beneficial to the university.

The Basics of the Solar Resource and Solar Power

The sun is vital to life on earth. It not only provides the warmth needed for a temperate climate, but also provides the light needed for vision and the energy needed for plants to perform photosynthesis. The U.S. Department of Energy (n.d.) states that humans have continually discovered new ways to use the sun in technology. From using magnifying lenses and sunlight to start fires to cooking food with a solar collector, the

Table 3

Lynchburg Weather Details by Month

Month	Average Temperature (°C)	Average Wind Speed (km/h)
January	1.7	10.5
February	3.4	10.6
March	7.7	11.4
April	13.0	11.6
May	17.3	9.7
June	22.0	8.4
July	24.1	7.7
August	23.4	7.2
September	19.4	8.0
October	13.4	8.4
November	8.2	9.2
December	3.1	9.3

Note. The average wind speeds are well below what is needed for wind power to be a reasonable option. Data for table retrieved from “Comparative Climatic Data for the United States Through 2015” by the U.S. Department of Commerce, National Oceanic and Atmospheric Administration (n.d.), <https://www1.ncdc.noaa.gov/pub/data/ccd-data/CCD-2015.pdf>.

solar resource has been consciously used for valuable purposes. Some noticed that light from the sun could be converted into electricity, but the significance of this discovery was inconsequential until the twentieth century.

Photovoltaic technology is pivotal because it is a way to generate electric power from a resource that is free and widely available throughout the earth. According to the U.S. Department of Energy (n.d.), the first photovoltaic solar cell was created with an efficiency of 4% in 1954. Green et al. (2018) shows that since that time, these cells have been increasing in efficiency, with one cell even reaching the experimental efficiency of 46%. Retail cells have much lower efficiencies currently and may never reach those heights, but this still shows that the possibility for such high efficiencies exists.

Solar cells receive energy from solar radiation in three different forms. Masters (2013) writes that they receive energy directly from the sun, from scattered sources where the sun's energy has been diffused by particles in the atmosphere, and from reflected surfaces on the ground. The energy directly from the sun is also called direct normal irradiation and the diffused energy is also called diffuse horizontal irradiation. Unless there is a reflective surface such as snow or water on the ground, the reflected energy is usually negligible, so the sum of the direct normal irradiation and the diffuse horizontal irradiation is considered more important and is called the global horizontal irradiation. Measurements for these sources of energy are important in determining whether solar power generation is a good option for a given location. The measurements of solar radiation are usually given in kWh/m². With a clear sky and a surface normal to the sun,

about 1 kWh/m² of solar radiation is received on the surface, so 1 kWh/m² is often called 1 peak sun-hour.

Photovoltaic Power Generation Facility Design

After it has been determined that a photovoltaic power plant would be a good option for the university, many of the details must be selected. This section of the paper details why a selection must be made for each of the following elements, presents some of the options available and reasons for choosing them, and then chooses one that fits Liberty University's situation the best.

Standalone or grid-connected. The choice of connecting a power generation system to the grid or leaving it standalone is a foundational one. For some organizations, it could result in the utility paying them if excess energy is sold to the utility or it could result in security against power outages.

Factors to consider. For a solar plant to be standalone, it usually must have expensive batteries to store energy that is not used during the day. On the other hand, to connect to the grid, there must be safeguards in place to ensure that power does not continue to be sent into the grid during a power outage in order to protect the safety of workers who will be fixing whatever has broken in the grid, according to Masters (2013). Grid-connected systems allow the consumer to continue to use electricity from the grid if the photovoltaic system does not produce enough to meet the needs of the consumer or to feed electricity into the grid if the photovoltaic system produces more electricity than the consumer needs.

Choice for Liberty University. Because of the university's power needs and the projected size of this system, the photovoltaic power plant design will be grid-connected. The expensive nature of batteries at this time supports the choice of a grid-connected system. Masters (2013) states that a grid-connected system will not require significant extra wiring and that it will permit the use of power from either the photovoltaic plant or from the utility.

Generation capacity. One of the first characteristics of the photovoltaic plant to consider is how much power it should generate. This will help determine the number of solar panels needed as well as the size of any inverters.

Factors to consider. The main factor to consider when determining the generation capacity of the plant is the overall goal for the system. For a utility, there may be a need to increase the maximum capacity of the grid to match peak demand that would determine the necessary capacity of the plant. Residential parties may choose a capacity based on the maximum amount of energy the utility will buy from a single customer if the utility buys energy that is added into the grid. For a commercial situation, the desire to offset the peak load of the organization at a key time could help to determine the right capacity.

Choice for Liberty University. The main criteria chosen for this situation was to choose a size that would demonstrate the effectiveness of a photovoltaic power plant while also never feeding excess energy back into the grid. This would ensure that Liberty would not rely on the utility to buy any power from its photovoltaic power generation facility and that no power would need to be stored in batteries.

In order to choose a capacity that is less energy than Liberty uses at any time throughout the year, the energy usage data set for Liberty's main campus was obtained (Liberty University Power Usage Data, 2017). Throughout the entire year, Liberty's main campus is using several MW of power at any time in the afternoon, when a solar power plant would be generating electricity.

The chosen capacity for Liberty University is then 1 MW. While this is small in comparison to some power plants, this size would still demonstrate the effectiveness of the system and make a difference in the budget to the university. To allow for a larger system, the system is designed in modular chunks of 500 kW. This means that if it is determined that a larger system is more beneficial to the university, it will be simple to add another 500 kW of generation to the current design. For this design, though, a capacity of 1 MW is used as the baseline for choosing the rest of the components.

Type of solar panel. The choice of solar panel may be the most significant choice that is made. In the last several years, many types of solar panels have become viable options, so each must be considered in turn. Masters (2013) writes that there have been three generations of photovoltaic cells so far; the first are thick single junction semiconductors, the second are thin-film semiconductors, and the third include multijunction tandem cells and quantum dots.

Survey of options available. The main options that are currently available on the market are first-generation monocrystalline or polycrystalline cells and second-generation thin-film cells, while the third-generation cells are still being developed. Monocrystalline

cells are the most efficient and oldest type of cell. According to Masters (2013), they are produced using the Czochralski process and are the most expensive type of cell.

Polycrystalline cells also have a proven history, but have existed for a shorter time than the monocrystalline cells. Masters (2013) states that polycrystalline cells are less efficient than the monocrystalline cells because of defective atomic bonds created by the cheaper processes used to create these cells. These cells have become the most common throughout the industry.

Finally, thin-film cells can be made using several different materials. These cells are newer and may develop further, but currently have lower efficiencies than the crystalline cells. However, according to Masters (2013), this can be offset by the cheaper materials that compose thin-film cells and their reduced complexity. The first example of a thin-film technology is amorphous silicon, which can be used to create multi-junction cells. An atypical example is gallium arsenide cells, which are made of more expensive materials and require a more expensive fabrication process, but have higher efficiencies than the crystalline cells. Cadmium telluride cells are more characteristic of the typical thin-film cell because they feature lower efficiencies and cheaper prices, but they also contain a material that is toxic to humans. This concern must be kept in mind to ensure safety. The last example of a thin-film cell is the copper indium selenide cell, which are slightly more efficient than the cadmium telluride cells.

Factors to consider. In choosing the type of cell to use in a design, the main tradeoff is space and efficiency. Higher efficiencies mean that a solar array will take up less space, while lower efficiencies mean that a solar array must take up more space to

produce the same amount of power. The other main factor is historical reliability. Masters (2013), indicates that the historically reliable silicon crystalline cells, whether mono- or polycrystalline, can reach efficiencies of at least 24%. On the other hand, thin-film cells provide less historical experience and vary widely in efficiency by type.

After determining the type of cell to use, the exact model must be chosen from among the different manufacturers. The efficiency of the cell is usually thought of as the most important characteristic, but other potential impactful factors include the operating voltage and current levels, the open-circuit voltage, and the short-circuit current. In addition, the size of the panels must be considered when an actual system is being designed.

Choice for Liberty University. Based on their widespread use throughout the industry and proven track record, polycrystalline cells were chosen for this design. In order to select specific panels, those used in nearby projects were considered. One example is in Bedford, VA, where REC Twinpeak 2S 72 Series solar panels are being used which are made up of polycrystalline cells. While these cells do not have the highest possible efficiency, they are also usually less expensive, so the main loss is that they take up more space. However, the available property for Liberty University indicates that this is a good tradeoff to make for this design, so these REC panels are used. These panels have a number of distinguishing characteristics which can be found in Table 4.

Type of inverter. The type of inverter that will be used in a system is the major electrical component to choose other than the panels. Inverters are used to convert DC

Table 4

Key Characteristics of the REC355TP2S 72 Solar Panel

Nominal Power	355 W
Nominal Power Voltage	39.1 V
Nominal Power Current	9.09 A
Open Circuit Voltage	46.8 V
Short Circuit Current	9.78 A
Panel Efficiency	17.7%
Nominal Operating Cell Temperature	44.6° C
Length	2.005 m
Width	1.001 m
Area	2.01 m

Note. Data retrieved from *REC TwinPeak 2S 72 Series* by REC Solar (n.d.),

https://usa.recgroup.com/sites/default/files/documents/ds_rec_twinpeak_2s_72_series_rev_b2_eng.pdf.

power from solar panels to AC power for the grid. There are now many types of inverters available, all with different benefits and drawbacks.

Survey of options available. Inverters are usually categorized by their size.

According to Yilmaz and Dincer (2017), there are central inverters, which are used for many strings of photovoltaic panels, string inverters for one string of photovoltaic panels each, and microinverters for one photovoltaic panel each. Kim and Winston (2014) state

that central inverters have been used in larger projects with success for many years, while the smaller inverters, which can be more efficient, have not yet demonstrated the same reliability due to their relative youth.

Factors to consider. The size of the project under consideration is a major factor to consider when choosing the inverter. For a single home with solar panels on the roof, the choice will often clearly favor microinverters. However, according to Fu, Feldman, Margolis, Woodhouse, & Ardani (2017), a large project will typically benefit more from the economy of scale provided by the central inverters than from the modularity offered by microinverters.

Again, after choosing the type of inverter, a specific model must be chosen from the relevant manufacturers. Several characteristics can be important in this case, including the maximum output, number of inputs, maximum input voltage, and maximum input current. These characteristics will each impact the end design of a system.

Choice for Liberty University. Because of the reliability of the central inverters, they are chosen for this design. The central inverters also tend to be cheaper per watt than smaller inverters, so that will be taken advantage of in this case. The specific inverter chosen is ABB's 500 kW PVS800. The model chosen for this design was selected because of a high number of inputs and high voltage and current input maximums. The key data for this inverter can be found in Table 5.

Location. The location of a solar plant is less important than for other types of power plants. Solar panels are unobtrusive and have little effect on surrounding wildlife according to prior studies (Lazaroiu, Longo, Roscia, & Pagano, 2015;

Table 5

Key Characteristics of the PVS800-57-0500kW-A Central Inverter

DC MPPT Range	450 to 825 V
Maximum DC Voltage	1100 V
Maximum DC Current	1145 A
Number of protected DC inputs	4 to 15
Nominal AC Power	500 kW
Maximum AC Power	600 kW
Maximum Efficiency	98.6%

Note. Data retrieved from *ABB central inverters PVS800 – 500 to 1000 kW* by ASEA

Brown Boveri (2017), <https://search->

[ext.abb.com/library/Download.aspx?DocumentID=3AUA0000057380&LanguageCode=en&DocumentPartId=1&Action=Launch](https://search-ext.abb.com/library/Download.aspx?DocumentID=3AUA0000057380&LanguageCode=en&DocumentPartId=1&Action=Launch).

Seyedmahmoudian, Kavalchuk, Horan, Oo, & Stojcevski, 2015). After they begin operating, solar panels do not emit any gases at all. They are quiet and should not be a nuisance to the surrounding population.

Factors to consider. One factor to consider is the topography of the location and its surroundings. If the location is not perfectly flat, its slope could either allow for the solar panels to take up more or less space depending on the fixed or tracking angle at which they will be set.

Another factor to consider for the location of the plant is the availability and use of transmission and distribution lines. Soleimani and Mazloun (2017) state that transmission lines are expensive, so existing transmission lines should be used if they are available. The distance from the power generation to the point of power usage also results in increasing losses. According to Masters (2013), transmission line power losses equal the product of the square of the current (I) through the line and the resistance (R) of the transmission line. The resistance of the line is proportional to the length of the line (l) and the resistivity of the line's material (ρ) and inversely proportional to the cross-sectional area of the line (A), as shown in Equation 2. Thus, based on Equations 1 and 2, the distance from the plant to the load should be minimized.

$$\text{Power Losses} = I^2 \times R \quad (1)$$

$$R = \frac{\rho \times l}{A} \quad (2)$$

Choice for Liberty University. An example of a location that works well for this design is about 3 miles to the east of Liberty's main campus, as shown in Figure 3. Liberty University already owns this 200-acre property, of which only a small fraction is needed for this project. This location has an elevation between 800 and 825 feet above sea level and a slight south-facing slope which allows the solar panels to be slightly closer together, therefore taking up less space overall, as is discussed later. Finally, new

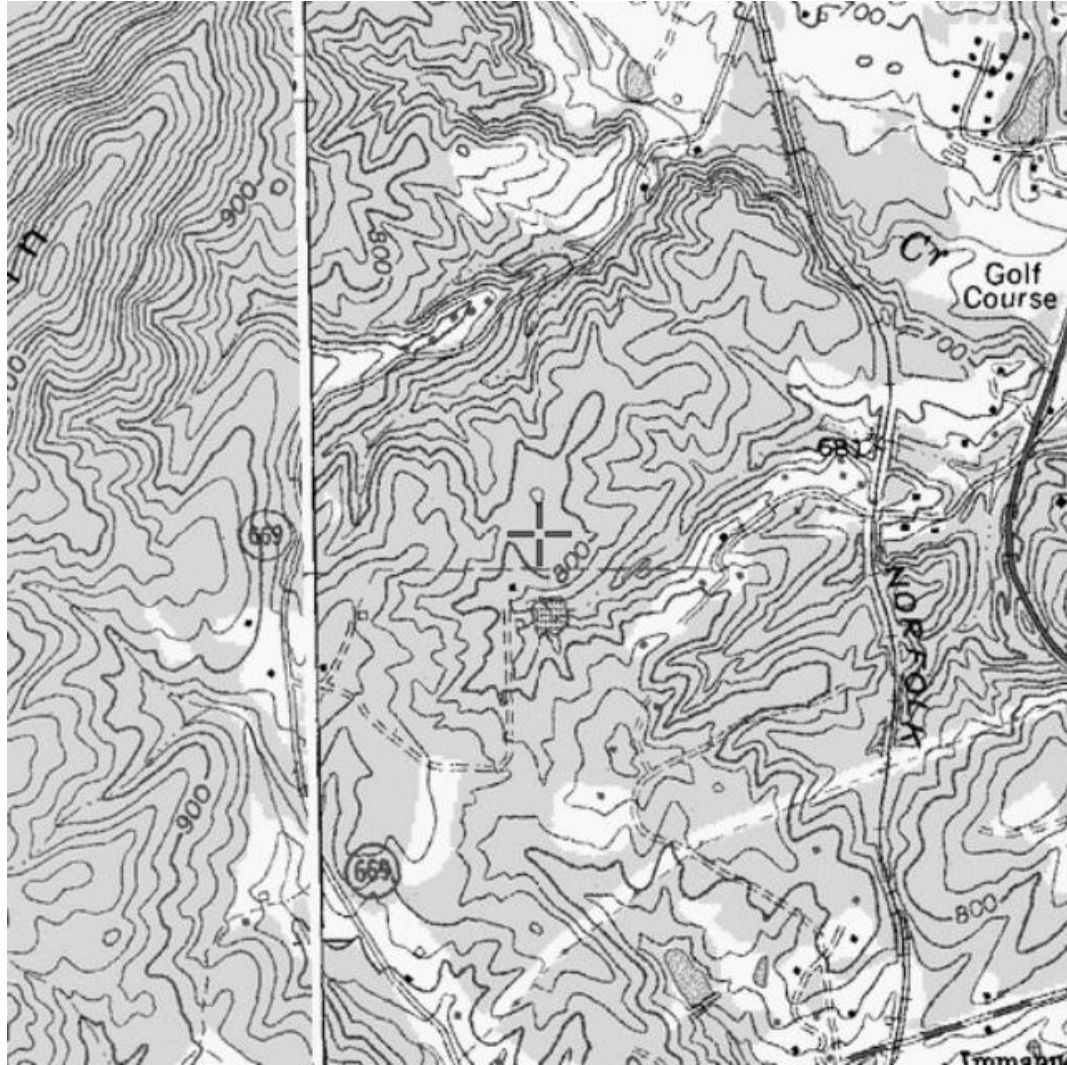

Figure 3. Topographical map of the proposed location of the system at the crosshairs.

Map reproduced from TopoQuest by Niemi (n.d.),

<https://www.topoquest.com/map.php?lat=37.34034&lon=->

[79.12012&datum=nad27&zoom=4&map=auto&coord=d&mode=pan&size=s&cross=on.](https://www.topoquest.com/map.php?lat=37.34034&lon=-79.12012&datum=nad27&zoom=4&map=auto&coord=d&mode=pan&size=s&cross=on)

Public domain.

distribution lines may need to be constructed because of the location's distance from campus.

Type of mounting. There are many ways to mount solar panels. From fixed mount to single-axis tracking to two-axes tracking, there are many tradeoffs that can be made. Additionally, solar panels can often be mounted on the rooftops of buildings, which is an option that should not be ignored.

Options available. A combination of two choices are made in this section. One choice concerns how the panels will be mounted. The other choice will determine whether the system will have a tracking system.

Roof-mounted. Solar panels can be mounted on the rooftops of buildings, although this raises many different challenges because the solar panels must be carefully attached and supported. Horizontally mounting panels results in a situation where water does not runoff the panels, but solar panels that are set at an angle require more support due to wind, so horizontally mounting the panels is the best option in many cases for roof-mounting.

Roof-mounting also limits the capacity of the solar plant based on the size of the roof. However, no buildings are present at the proposed location, so roof-mounting is not a real option in this case.

Ground-mounted. If solar panels are mounted on the ground, the wind concerns are not usually quite as high because of the wind-breaking effects of the surroundings. This will allow for installation angles for the solar panels that may be more effective than the preferred horizontal installation on a rooftop. Ground-mounted arrays are also limited in size only by how much land is available.

Fixed mount. This is the simplest option. The solar panels could be set at an angle designed to achieve maximum benefits based on the area available for the panels. The most obvious way to set the panels up other than flat is south-facing to an angle equal to the location's latitude because the sun is consistently in the southern portion of the sky for any location north of the Tropic of Cancer, which is 23.44° north of the equator.

Single-axis tracking. This option requires some type of motor to rotate the panel along a single axis. Masters (2013) states that this increases the cost but also increases the potential output that can be gained from pointing the panel normal, or closer to normal, to the sun. The most beneficial axis along which to rotate the panel is the North-South axis, so that the panel can point in an East direction in the morning and a West direction in the evening.

Two-axes tracking. This option is very expensive and usually results in less benefit than the effort that is expended to gain what that benefit costs. Masters (2013) indicates that while a single-axis tracking system often has significant advantages over a fixed-mount system, a two-axis tracking system provides fewer advantages. A comparison among fixed, single-axis, and two-axis systems is in Figure 4.

Choice for Liberty University. The fixed-axis ground-mounted option is used for this design. The system is ground-mounted to avoid the structural and wind concerns that come from roof-mounting. The system is fixed rather than tracking to eliminate the need for motors that would increase installation costs and which could also require regular maintenance as they break down or work less effectively over time. The angle of mounting is chosen next.

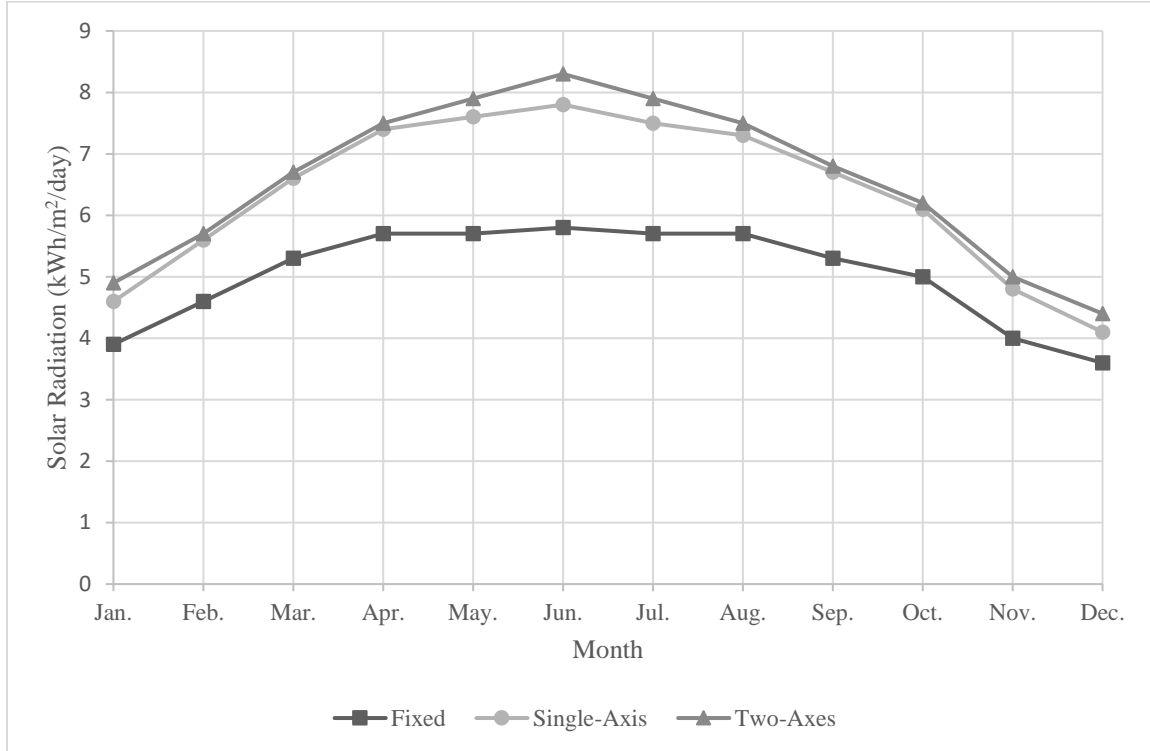

Figure 4. Monthly solar radiation received by Lynchburg collectors. The single-axis collectors offer significant improvement over fixed-axis collectors, but the two-axes collectors are only slightly better than the single-axis collectors. Data for figure retrieved from *Solar Radiation Data Manual for Flat-Plane and Concentrating Collectors* by Marion and Wilcox (1994), Golden, CO: National Renewable Energy Laboratory.

Installation angle for solar panels. Based on the decision to use a fixed-mount for the solar panels, an angle must be chosen. This angle will be chosen to minimize the space needed for the panels and to maximize the solar radiation that the panels receive.

Factors to consider. Masters (2013) writes that panels which are normal to the sun receive the maximum amount of solar radiation. However, the earth faces the sun at different angles throughout a day because the earth is constantly rotating. For one string

of solar panels, the ideal angle is the same angle as the location's latitude. However, with more strings of panels, shading effects must be considered, which could result in a different angle being chosen.

Choice for Liberty University. Based on software simulations using the National Renewable Energy Laboratory's PVWATTS online tool (n.d.), an angle of around 30° would be the lowest angle that would receive around the peak average solar radiation in Lynchburg. This angle then corresponds to a ground coverage ratio (GCR) that optimizes the use of space by minimizing the shading that modules receive from rows in front of them. According to Masters (2013), a shading derate factor of 0.975 is a good number to aim for because it represents just a 2.5% power loss and avoids the decreasing marginal benefits of spreading the module rows farther apart. This then results in a GCR of 0.47, which means that the solar panels cover 47% of the total area of the system.

$$\text{Distance Between Rows} = \text{Panel Width} \times \frac{(1 - \text{GCR} \times \cos(\angle_{\text{Panel}}))}{\text{GCR}} \quad (3)$$

Based on the GCR and panel width of 1.001 m, this would result in a distance between rows of strings of 1.26 m. However, the property location chosen for this system has a 7% south-facing grade, which is about a 4° angle, so the installation angle can instead be 26° to achieve the same angle relative to the sun. This requires several different calculations to achieve a similar amount of shading as the 0.47 GCR, which will be used later.

Upkeep considerations. One aspect of a solar plant that may be often forgotten is the upkeep that should be done to keep it performing at a peak level. Deb and Brahmabhatt (2018) state that one of the benefits of a solar plant is the minimal cost of operations and maintenance as compared with a traditional power plant, but a small amount of upkeep can make a big difference to some solar plants. The manufacturer, REC Solar (2014), instructs that the main way to upkeep the power plant is by washing the panels periodically. For the solar panels chosen for this project, the manufacturer states that rainfall should typically clean them sufficiently, but if dirt is visible, cleaning it off can help to eliminate unnecessary reductions in the generation of electricity.

Results

All of the system components have been chosen, so what remains is to determine the layout of the solar panels and to calculate the power output of the system. This will indicate how each of the design choices have fared.

Design Details and Calculations

Based on the components that have been chosen for this design, several details can ultimately be worked out. These include details about the layout of solar panels, the number of solar panels in a string, the number of strings per input to the inverter, and the distance between strings. The layout of the solar panels will also determine the total area needed for the plant. This process follows the example given by Masters (2013).

The number of solar panels needed to reach the 1-MW goal of this project is simple. Because a peak sun hour results in solar insolation of 1 kW/m^2 for a normal flat

collector, the area of the solar panels must be 1000 square meters divided by the efficiency of the panels.

$$\text{Area of Panels} = \frac{\frac{\text{System Output}}{1 \text{ Peak Sun} \cdot \text{Hour}}}{\text{Panel Efficiency}} \quad (4)$$

The panel efficiency is 17.7%, so the total area of the panels needs to be 5,650 square meters. The area of each panel is the product of the panel's length, 2.005 m, and the panel's width, 1.001 m, which is 2.01 m². When the total area of the panels is divided by the area of each panel, the minimum number of panels that is needed is found to be 2,811.

$$\text{Minimum Panels} = \frac{\text{Total Area of Panels}}{\text{Area of One Panel}} \quad (5)$$

This is also confirmed by dividing the desired output of the system, 1 MW, by the output power of each panel, 355 watts, which gives a panel minimum of 2,817.

The number of solar panels in a string is determined by the voltage characteristics of the solar panels and inverters. The rated voltage of the solar panels is 39.1 volts, while the maximum power point tracking range for the inverters is 450 to 825 volts.

$$\frac{\text{Maximum Panels}}{\text{String}} = \frac{V_{\text{High}}}{V_{\text{Panel}}} \quad (6)$$

$$\frac{\text{Minimum Panels}}{\text{String}} = \frac{V_{\text{Low}}}{V_{\text{Panel}}} \quad (7)$$

This means that the minimum number of panels per string is 12 and the maximum number of panels per string is 21. The next value that comes into play is the maximum voltage that the panels reach when they are cold, which is higher than the normal voltage. Based on data from the U.S. Department of Commerce (n.d.), the lowest temperature ever recorded in Lynchburg is -24° Celsius. The ambient temperature can be used as the minimum temperature of the cell.

$$V_{\text{Panel,Modified}} = V_{\text{Panel,Rated}} \times (1 + (T_{\text{Cell}} - T_{\text{STC}}) \times C_{\text{Temperature}}) \quad (8)$$

When combined with the temperature coefficient of voltage of the panels, which is $-0.3 \text{ \%/}^{\circ}\text{C}$ and the standard temperature of 25°C , this gives a voltage of 44.8 volts for each panel. From the upper limit of the inverter tracking range of 825 volts and Equation 6, this gives a new maximum number of panels per string of 18. In addition to staying in the tracking range, the open-circuit voltage of the panels should stay under the unqualified maximum input voltage of the inverters, particularly when cold. The open-circuit voltage of the panels is 46.8 volts, which becomes 53.7 volts when it is cold in Lynchburg based on Equation 8. The maximum input voltage to the inverters is 1,100 volts, so this gives a maximum number of modules per string of 20 based on Equation 6, which is higher than the previously determined maximum of 18. Finally, the minimum voltage that the panels reach when they are hot should be considered. The U.S.

Department of Commerce (n.d.) has a highest recorded temperature of 40° C for Lynchburg. When finding the maximum temperature of a cell, the quotient of a dividend consisting of the difference between the nominal operating cell temperature (NOCT), which is 44.6° C in this case, and 20° C and a divisor consisting of the solar insolation of 0.8 kW/m² should be used to find the real temperature of the cell, as shown in Equation 9.

$$T_{\text{Cell}} = T_{\text{Amb}} + \frac{\text{NOCT} - 20}{0.8} \quad (9)$$

The maximum cell temperature is then 70.8° C and Equation 8 results in a minimum voltage of 33.7 volts for each panel. From the lower limit of the tracking voltage of the inverters of 450, a minimum of 14 panels per string is found. Putting all of this together, there must be at least 14 panels per string but no more than 18. From this range, 16 panels per string was chosen.

The number of strings per input to the inverter is determined by current characteristics of the solar panels and inverters as well as the maximum inputs to the inverter. The maximum input current to each inverter is 1,145 amperes. Each string of solar panels can output up to the short-circuit current of 9.78 amperes, although the nominal current is 9.09 amperes.

$$\frac{\text{Maximum Strings}}{\text{Inverter}} = \frac{I_{\text{Input,Max}}}{I_{\text{SC,Panel}}} \quad (10)$$

That means, based on the current, that each inverter can have a maximum of 117 strings input to it. Based on the previously found minimum number of panels of about 2,800, a value of 2,880 panels is chosen because it is the product 180 and 16. Each inverter will then have 90 strings input to it. The maximum number of inputs per inverter is 15, so 10 combiner boxes will be used per inverter to combine 9 strings into 1 input to the inverter. The output of each combiner box will be 1 input to the inverter, so each inverter will have 10 inputs.

The total area of the system can be determined now based on the number of strings, dimensions of the panels, and distance between the rows. A design of 4 strings per row and 45 rows can be used. Equation 11 then results in a length of 128.32 meters.

$$L_{\text{System}} = \text{Strings} \times \frac{\text{Panels}}{\text{String}} \times L_{\text{Panel}} \quad (11)$$

The width of the system will then be 45 rows multiplied by the distance on the ground from the front to the back of the panel, which is cosine of 26° multiplied by the width of the panel of 1.001 meters, all added to 44 spaces between the panels. The previously calculated distance between the panels was 1.26 m, but that is for a flat property. The property chosen has a 4° angle down to the south, so the panels will be able to be closer together, as shown in Figure 5. With flat ground, the angle from the bottom of one row to the top of the one in front of it is 21.6° . Adding 4° to this means that there will be an angle of 25.6° for this system. Based on the following equations, the distance

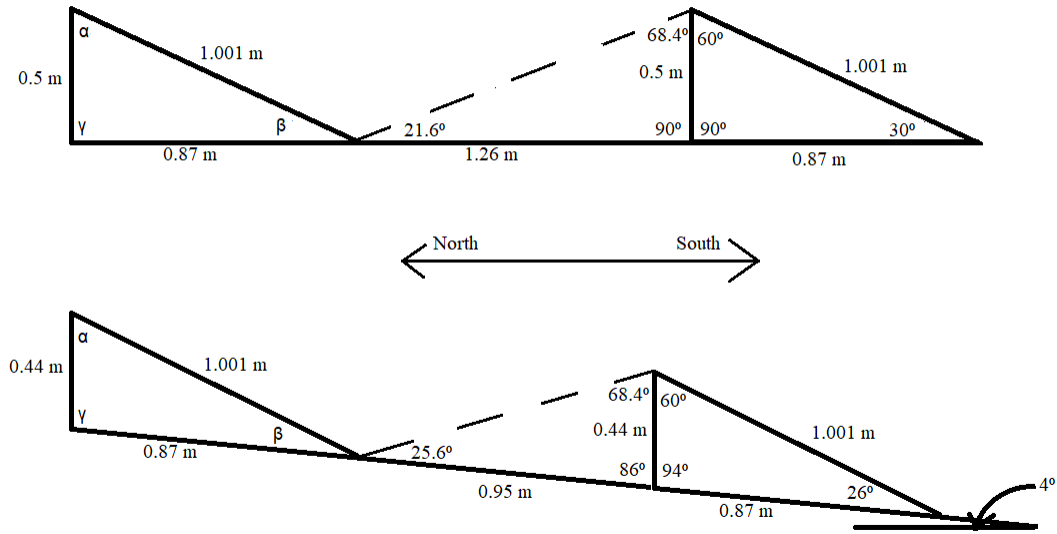

Figure 5. Solar collectors on a flat surface with a ground coverage ratio of 0.47 are above while solar collectors on a 4° slope are below. The collectors can be closer together on the sloped surface and still have the same amount of shade covering.

between the panels will be 0.95 m, while the distance of ground under the panel will be 0.87 m.

$$H_{\text{Panel}} = \frac{W_{\text{Panel}} \times \sin(\angle_{\text{Panel}})}{\sin(90 + \angle_{\text{Slope}})} \tag{12}$$

$$\angle_{\text{Vertical, Between Rows}} = 180^0 - (90^0 - \angle_{\text{Slope}}) - \angle_{\text{Shading}} \tag{13}$$

$$W_{\text{Between Panels}} = \frac{H_{\text{Panel}} \times \sin(\angle_{\text{Vertical, Between Rows}})}{\sin(\angle_{\text{Shading}})} \tag{14}$$

$$W_{\text{Panel on the Ground}} = \frac{W_{\text{Panel}} \times \sin(\alpha)}{\sin(\gamma)} \quad (15)$$

$$W_{\text{System}} = \text{Rows} \times W_{\text{Panel on the Ground}} + (\text{Rows} - 1) \times W_{\text{Between Panels}} \quad (16)$$

$$A_{\text{Panels, Total}} = L_{\text{System}} \times W_{\text{System}} \quad (17)$$

Based on Equation 17, the area used by the system's panels and the space between them is then 10,390 square meters, or 2.57 acres. Additionally, a small amount of space will be needed for the inverters and other electrical equipment.

The total output of the system could vary from year to year, but an expected value can be calculated from the details previously determined and an additional derate factor. Masters (2013) states that this derate factor is a combination of many factors that can hinder the system's performance, including inverter inefficiencies, wiring between the components, soiling, and shading. Because of the care that will be taken to maintain the solar panels to reduce losses caused by soiling, a slightly higher value of 0.78 was chosen for the derate factor rather than the more typical 0.77. This can then be multiplied by the number of modules, the output power of each module, the solar radiation that the panels receive per day, and 365 days per year to result in a value of about 1,490,000 kWh/year.

$$\frac{\text{Energy}}{\text{Year}} = \text{Derate Factor} \times \text{Panels} \times \frac{\text{Power}}{\text{Panel}} \times \frac{\text{Solar Radiation}}{\text{Day}} \times \frac{\text{Days}}{\text{Year}} \quad (18)$$

Design Summary

The plant that has been designed as a result of this analysis can now be summarized. There are 16 panels per string with 180 strings in total. There are two central inverters, which will utilize 10 inputs each.

$$\text{Panel Total} = \text{Inverters} \times \frac{\text{Inputs}}{\text{Inverter}} \times \frac{\text{Strings}}{\text{Input}} \times \frac{\text{Panels}}{\text{String}} \quad (19)$$

The entire system takes up about 2.57 acres, based on Equation 17. The maximum output of the system based on the inverters is 1,000 kW, which is the system design goal, although the maximum DC output of the solar panels is a little greater than 1,000 kW, providing a DC-to-AC ratio of about 1.02.

$$\text{DC:AC Ratio} = \frac{\text{Solar Panel Maximum DC Output}}{\text{Inverter Maximum AC Output}} \quad (20)$$

The expected annual production of the system is 1,490,000 kWh based on Equation 18 and is shown by month in Figure 6.

Discussion

The primary motivation to complete this project is the potential financial benefit that the university would see. Nuortimo, Härkönen, and Karvonen (2018) indicate that some positive media coverage and some environmental benefits would result from a photovoltaic power plant. However, it is likely that saving money is the main reason an

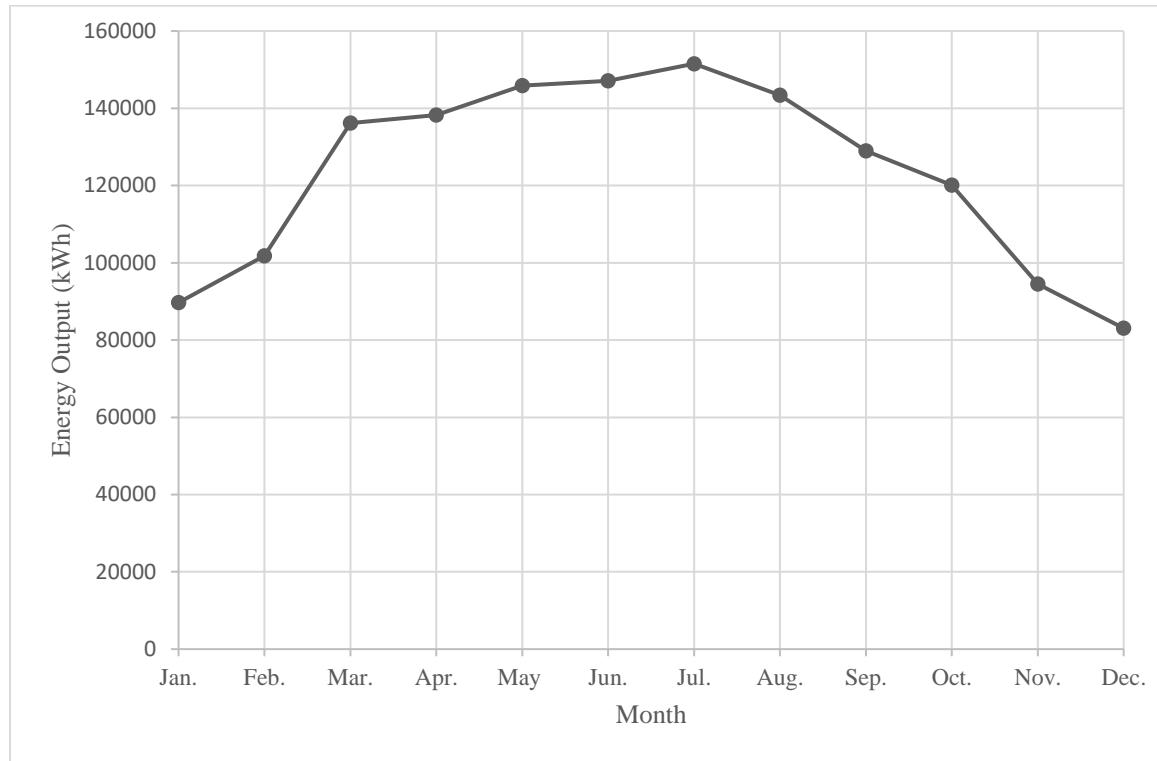

Figure 6. Monthly energy output of the system. The system output peaks in the late spring and summer.

organization would install solar panels. Several reasons why this project may save money are included below.

Little Transmission Loss

When the utility sells power to a customer, it must travel along a line for a certain distance. Tian, Gai, and Qu (2017) provide an example of a transmission system in Shandong Province, China that is 58.4 km, or 36.3 miles, long, which is much longer than the system that would be needed for this project. As indicated by Equation 1, whenever current is traveling along a line, the losses equal the square of the current times the resistance of the line. This means that the shorter distance that the power from the

solar plant would travel to the university than it might from a different power plant could make the power cheaper than the utility could provide. This is one of the major reasons that this project could save the university money.

No Middle Man

Another reason that the power from the solar project could save the university money is the removal of the profits that the utility is making from the equation. While utilities bring a valuable service to the economy, if an organization can produce its own power at a certain scale, there may be significant cost savings because of a general lack of competition for the utility, which allows it to sell power for a higher price based on supply and demand.

Low Operational and Maintenance Costs

The above factors would apply to any power plant that the university owned, but renewable power plants and specifically solar power stand out for one other reason. They have no or very low operations and maintenance costs. While a coal power plant continually needs more coal as fuel to operate, a solar power plant simply waits for the sun to come back up for its fuel. While there may be some benefits to activities with minor maintenance costs, like cleaning the panels, the costs incurred are insignificant compared to the operational costs faced by traditional power plants.

Future Research

This paper has shown the reasoning behind many different choices that must be made in the design of a photovoltaic power plant. However, there is more work to be done beyond this paper to determine the feasibility of the project. The goal is to set up

any organization, but especially Liberty University, to be able to take the next step if it chooses to do so.

Financial analysis. The main reason this paper cannot confidently claim that a photovoltaic power plant would be a practical option for Liberty University is because no financial analysis is attempted. Many of the costs of components, including the solar panels and inverters, are not readily available to the public. The financial resources and willingness of the university to do a project like this are not fully known. The university may or may not even be willing to dedicate property to this project. A person with this kind of knowledge would be better equipped to make this analysis and determine if the project should be pursued or prioritized by the university.

Potential improvement of options that were discarded. In the future, it is possible that technology advances or price changes will make the reasoning for several of the choices made for this design wrong. If a certain type of solar cell becomes much more efficient, it may become the clear option for most designs. If a material used to make another solar cell increases rapidly in price, it may become an option that can be safely ignored. Any number of technology advances could fundamentally change the value of a solar power plant.

Analysis of overlooked options for Liberty University. Finally, small factors that were not considered or known for this paper could mean that some options are better or worse than this paper assumed. The university could decide that instead of designing a 1-MW plant, it would like to use its rooftops as the location for a solar power plant, regardless of the exact amount of power that will be generated. This would change many

things about this analysis and shows why this paper is just one example of the many ways that this problem could be approached.

Conclusion

Solar power appears to be on the rise throughout the United States and around the world. Increasing efficiencies of solar panels and decreasing costs, combined with continued subsidies means that many sensible organizations and individuals will continue to consider installing them. In addition to the cost savings, there are potential environmental benefits that cannot be ignored as solar power systems are considered. Based on this analysis, a photovoltaic system is worth considering for Liberty University. More research will need to be done, but a good stepping-stone has been provided. Improvements can be made on the design presented and future researchers can compare their designs against the baseline design in this paper.

References

- ASEA Brown Boveri. (2017). “*ABB central inverters PVS800 – 500 to 1000 kW*” [Data sheet]. Zurich, Switzerland: Author. Retrieved from <https://search-ext.abb.com/library/Download.aspx?DocumentID=3AUA0000057380&LanguageCode=en&DocumentPartId=1&Action=Launch>
- Berwal, A. K., Kumar, S., Kumari, N., Kumar, V., & Haleem, A. (2017). Design and analysis of rooftop grid tied 50 kW capacity solar photovoltaic (SPV) power plant. *Renewable and Sustainable Energy Reviews*, 77, 1288-1299.
doi:10.1016/j.rser.2017.03.017
- Cgulyas2002. (2008, December 12). *Combiner box* [Photograph]. Retrieved from <https://www.flickr.com/photos/gulyas/3107779984/in/album-72157611250254270/>
- Colorado State University. (n.d.). Sustainability in facilities management at Colorado State University. Retrieved January 22, 2018, from <https://www.fm.colostate.edu/sustain/>
- Corneli, S., & Kihm, S. (2016, June). Will distributed energy end the utility natural monopoly? *Electricity Daily*, 2. Retrieved from https://emp.lbl.gov/sites/default/files/corneli_29june2016.pdf
- Deb, D., & Brahmhatt, N. L. (2018). Review of yield increase of solar panels through soiling prevention, and a proposed water-free automated cleaning solution. *Renewable and Sustainable Energy Reviews*, 82, 3306-3313.
doi:10.1016/j.rser.2017.10.014

Eastern Mennonite University. (n.d.). Solar project. Retrieved January 22, 2018, from

<https://www.emu.edu/sustainability/solar>

Edelstein, W. A., Walcek, C. J., Cox, D. L., & Davis, L. (2003, September 12). *Wind energy*. Retrieved from

https://www.aps.org/policy/reports/occasional/upload/wind_energy.pdf

Fu, R., Feldman, D., Margolis, R., Woodhouse, M., & Ardani, K. (2017). U.S. solar photovoltaic system cost benchmark: Q1 2017. doi:10.2172/1395932

Gild, S. (2013, April 22). VU power plant to convert to all-natural gas. Retrieved January 22, 2018, from <https://www.vanderbilt.edu/sustainvu/2013/04/vu-power-plant-faq/>

Goodrich, A., James, T., & Woodhouse, M. (2012, February). *Residential, commercial, and utility-scale photovoltaic (PV) system prices in the United States: Current drivers and cost-reduction opportunities*. Retrieved

<https://www.nrel.gov/docs/fy12osti/53347.pdf>

Green, M. A., Hishikawa, Y., Dunlop, E. D., Levi, D. H., Hohl-Ebinger, J., & Ho-Baillie, A. W. (2018). Solar cell efficiency tables (version 51). *Progress in Photovoltaics: Research and Applications*, 26(1), 3-12. doi:10.1002/pip.2978

Research and Applications, 26(1), 3-12. doi:10.1002/pip.2978

Hausman, W. J., & Neufeld, J. L. (1990). The structure and profitability of the US electric utility industry at the turn of the century. *Business History*, 32(2), 225-243. doi:10.1080/000767990000000047

Hill, D. J. (n.d.). The solar strand. Retrieved January 22, 2018, from

http://www.buffalo.edu/home/feature_story/solar-strand.html

- Ho, C. K. (2016). Review of avian mortality studies at concentrating solar power plants. *AIP Conference Proceedings*, 1734, 070017. doi:10.1063/1.4949164
- Huston-Bursaw, Dalton. (2017, May 22). *An inverter on a 100 MW solar site* [Photograph]. Retrieved from <https://www.flickr.com/photos/departmentofenergy/35941357930>
- Kelly, M. (2017, July 20). UVA, Dominion Energy and Coronal Energy announce ambitious solar energy project. Retrieved January 22, 2018, from <https://www.news.virginia.edu/content/uva-dominion-energy-and-coronal-energy-announce-ambitious-solar-energy-project>
- Kim, Y. S., & Winston, R. (2014). Power conversion in concentrating photovoltaic systems: central, string, and micro-inverters. *Progress in Photovoltaics: Research and Applications*, 22(9), 984-992. doi:10.1002/pip.2317
- Lazaroiu, G. C., Longo, M., Roscia, M., & Pagano, M. (2015). Comparative analysis of fixed and sun tracking low power PV systems considering energy consumption. *Energy Conversion and Management*, 92, 143-148. doi:10.1016/j.enconman.2014.12.046
- Liberty University Power Usage Data. (2017). Unpublished raw data.
- Lu, X., McElroy, M. B., & Kiviluoma, J. (2009). Global potential for wind-generated electricity. *Proceedings of the National Academy of Sciences of The United States of America*, 106(27), 10933-10938. doi:10.1073/pnas.0904101106

- Marcy, C. (2018, January 10). Nearly half of utility-scale capacity installed in 2017 came from renewables. U.S. Energy Information Administration. Retrieved from <https://www.eia.gov/todayinenergy/detail.php?id=34472>
- Marion, W., & Wilcox, S. (1994). *Solar radiation data manual for flat-plane and concentrating collectors*. Golden, CO: National Renewable Energy Laboratory.
- Masters, G. M. (2013). *Renewable and efficient electric power systems* (2nd ed.). Hoboken, NJ: Wiley-Blackwell.
- National Renewable Energy Laboratory. (n.d.). PVWatts calculator [Web application]. Retrieved from <http://pvwatts.nrel.gov/pvwatts.php>
- Niemi, R. (n.d.). TopoQuest [Digital image]. Retrieved March 24, 2018, from <https://www.topoquest.com/map.php?lat=37.34034&lon=-79.12012&datum=nad27&zoom=4&map=auto&coord=d&mode=pan&size=s&cross=on>. Public domain.
- Nuortimo, K., Härkönen, J., & Karvonen, E. (2018). Exploring the global media image of solar power. *Renewable and Sustainable Energy Reviews*, 81, 2806-2811. doi:10.1016/j.rser.2017.06.086
- Perea, A., Honeyman, C., Mond, A., Shiao, M., Jones, J., Moskowitz, S., . . . Baca, J. (2017, December). *U.S. solar market insight*. Retrieved from <https://www.seia.org/sites/default/files/2017-12/U.S.%20Solar%20Market%20Insight%20Q4%202017%20-%20Executive%20Summary.pdf>

- Princeton University Office of Sustainability. (n.d.). Live data. Retrieved January 22, 2018, from <https://sustain.princeton.edu/lab/live-data>
- REC Solar. (2014). *Quick guide to cleaning ensuring the best performance of REC Peak Energy solar panels*. Retrieved from https://www.recgroup.com/sites/default/files/documents/quick_guide_cleaning_eng_0.pdf
- REC Solar. (n.d.). *REC TwinPeak 2S 72 Series*. Retrieved from https://usa.recgroup.com/sites/default/files/documents/ds_rec_twinpeak_2s_72_series_rev_b2_eng.pdf
- Romaniuk, B. (Ed.). (2018). *The college blue book* (45th ed., Vol. 1). Farmington Hills, MI: Gale.
- Romero-Cadaval, E., Francois, B., Malinowski, M., & Zhong, Q. (2015). Grid-connected photovoltaic plants: An alternative energy source, replacing conventional sources. *IEEE Industrial Electronics Magazine*, 9 (1), 18-32.
doi:10.1109/mie.2014.2362211
- Seyedmahmoudian, M., Kavalchuk, I., Horan, B., Oo, A. M., & Stojcevski, A. (2015). Viable approaches for increasing the efficiency of building integrated photovoltaic systems. *2015 Australasian Universities Power Engineering Conference (AUPEC)*. doi:10.1109/aupec.2015.7324864
- Sides, E. (2018, January 12). Town of Bedford begins offering electricity from local solar farm. *The News & Advance*. Retrieved from <http://www.newsadvance.com/news/local/town-of-bedford-begins-offering->

electricity-from-local-solar-farm/article_6788dd88-f7d7-11e7-be58-97b028e3484b.html

Skeeze. (2011, July 10). *Solar panel array, power, sun* [Photograph]. Retrieved from <https://pixabay.com/en/solar-panel-array-power-sun-1591350/>

Smith, R. (2016, November 22). Bedford town council approves solar farm project. Retrieved January 22, 2018, from http://www.newsadvance.com/work_it_lynchburg/news/bedford-town-council-approves-solar-farm-project/article_c3bd7c00-16c2-58cc-bfa2-3bca854c8059.html

Solar Energy Industries Association. (2017, September 9). Major solar projects list. Retrieved January 22, 2018, from <https://www.seia.org/research-resources/major-solar-projects-list>

Soleimani, K., & Mazloum, J. (2017). Considering FACTS in optimal transmission expansion planning. *Engineering, Technology & Applied Science Research*, 7(5), 1987-1995.

Tanțău, A. D., Regneală, H., & Coraș, E. L. (2014). Layout design as a risk driver for energy efficiency of photovoltaic power systems. *The International Journal of Management Science and Information Technology*, (11), 127-154.

Tian, L., Gai, X., & Qu, B. (2017). Shake table tests of steel towers supporting extremely long-span electricity transmission lines under spatially correlated ground motions. *Engineering Structures*, 132, 791-807.
doi:10.1016/j.engstruct.2016.11.068

- University of Illinois at Urbana Champaign Facilities and Services. (2015). Solar farm project. Retrieved from http://www.fs.illinois.edu/docs/default-source/news-docs/solar-farm-fact-sheet.pdf?sfvrsn=f209f9ea_2
- U.S. Department of Commerce, National Oceanic and Atmospheric Administration. (n.d.). Comparative climatic data for the United States through 2015. Retrieved <https://www1.ncdc.noaa.gov/pub/data/ccd-data/CCD-2015.pdf>
- U.S. Department of Energy, Office of Energy Efficiency and Renewable Energy. (n.d.). The history of solar. Retrieved from https://www1.eere.energy.gov/solar/pdfs/solar_timeline.pdf
- U.S. Energy Information Administration. (2017a, December 12). How much electricity does a nuclear power plant generate? Retrieved January 22, 2018, from <https://www.eia.gov/tools/faqs/faq.php?id=104&t=3>
- U.S. Energy Information Administration. (2017b, August 17). Virginia state energy profile. Retrieved January 22, 2018, from <https://www.eia.gov/state/print.php?sid=VA>
- Xiao, Q., Liu, H., & Feldman, M. W. (2017). How does trust affect acceptance of a nuclear power plant (NPP): A survey among people living with Qinshan NPP in China. *Plos One*, 12(11). doi:10.1371/journal.pone.0187941
- Yilmaz, S., & Dincer, F. (2017). Impact of inverter capacity on the performance in large-scale photovoltaic power plants – A case study for Gainesville, Florida. *Renewable and Sustainable Energy Reviews*, 79, 15-23. doi:10.1016/j.rser.2017.05.054