

Invited paper

Some Advances in the Circuit Modeling of Extraordinary Optical Transmission

Francisco MEDINA¹, Francisco MESA², Raúl RODRIGUEZ-BERRAL²¹Dept. of Electronics and Electromagnetism, University of Seville, Av. Reina Mercedes s/n, 41012, Seville, Spain²Dept. of Applied Physics 1, University of Seville, Av. Reina Mercedes s/n, 41012, Seville, Spain

medina@us.es, mesa@us.es, rrberral@us.es

Abstract. *The phenomenon of extraordinary optical transmission (EOT) through electrically small holes perforated on opaque metal screens has been a hot topic in the optics community for more than one decade. This experimentally observed frequency-selective enhanced transmission of electromagnetic power through holes, for which classical Bethe's theory predicts very poor transmission, later attracted the attention of engineers working on microwave engineering or applied electromagnetics. Extraordinary transmission was first linked to the plasma-like behavior of metals at optical frequencies. However, the primary role played by the periodicity of the distribution of holes was soon made evident, in such a way that extraordinary transmission was disconnected from the particular behavior of metals at optical frequencies. Indeed, the same phenomenon has been observed in the microwave and millimeter wave regime, for instance. Nowadays, the most commonly accepted theory explains EOT in terms of the interaction of the impinging plane wave with the surface plasmon-polariton-Bloch waves (SPP-Bloch) supported by the periodically perforated plate. The authors of this paper have recently proposed an alternative model whose details will be briefly summarized here. A parametric study of the predictions of the model and some new potential extensions will be reported to provide additional insight.*

Keywords

Extraordinary optical transmission, diffraction gratings, circuit modeling, open resonators.

1. Introduction

It is well known that the electromagnetic radiation transmittivity through electrically small apertures in opaque screens is extremely low [1]. However, if the holes are arranged into a 2D periodic array, the transmittivity per hole is, at certain particular frequencies, much higher than expected [2]. Although it was immediately appreciated that the wavelengths of the enhanced transmission and the period of the structure were closely connected, in a first stage it was the plasma behavior of metals at optical frequencies

what was thought to be essential to the phenomenon [3]. Thus, the interaction between the impinging wave and surface plasmon polaritons (SPP) supported by metal/dielectric interfaces was considered the reason behind EOT. The role of the holes would then be to add the grating momentum required to match the wave vector of the impinging wave to the wave vector of the SPP. However, it was soon clear that the constitutive relation of the metal is not specially relevant. Indeed, EOT is possible at frequencies for which metals are almost perfect conductors, such as was experimentally demonstrated to happen at millimeter-wave frequencies [4], [5] (in this case the term *optical* in EOT is clearly inappropriate). Further theoretical studies concluded that extraordinary transmission is possible even if the metal is considered as an ideal perfect conductor [6] (in this paper the reader can find an extensive review on the phenomenon). Nevertheless, the penetration of fields inside the metal and the plasma-like behavior of metals at optical frequencies was still considered to play some role [7].

Nowadays, the most accepted model in the frame of the optical community still gives primordial importance to SPP's but taking into account that these surface waves are not the waves supported by a flat (real) metal/dielectric interface but the surface waves supported by a periodically structured conducting layer (the metal layer with the holes). The key point is no longer that the holes are practiced on a perfect conducting screen or on a plasma-like screen. These waves are what people first called *spoof plasmons* [8], [9] or SPP-Bloch waves (these waves are the version for 2D structured surfaces of the waves supported by 1D corrugated surfaces that have been known in the microwave engineering domain since the forties of the past century [10, 11, 12] and more recently in the optics domain [13]). Direct evidence of the existence of these surface waves in 2D periodic structures has been recently reported in the THz regime [14] as well as in the microwave regime [15], although these results should not be surprising for microwave and antenna engineers. Enhanced transmission through aperiodic arrays of holes has also been reported [16], but the structures treated in that paper are quasi-crystals with some kind of periodicity at several length scales. In summary, SPP-Bloch waves interacting with planar uniform waves seems to be a good framework to explain EOT.

In spite of the successful theory based on SPP's, some of the authors of this paper have recently proposed a new paradigm [17], [18] which is simpler than SPP model, at least for people familiar with transmission line and circuit theory. Other additional advantages of our model are:

- it allows for an easy understanding of how each dimensional parameter affects the response of the extraordinary transmission structure,
- it easily leads to some simplified analytical formulas [19], and
- the extension to other systems exhibiting exotic transmission spectra, such as compound 1D gratings [20], is straightforward [21], [22].

However, what is more important from a conceptual point of view is that our theory does not make exactly the same predictions as the SPP theory. Our model is based on the concept of *impedance matching* rather than on surface wave excitation, and this makes that our theory predicts situations of extraordinary transmission where SPP's have no sense. This has been experimentally confirmed for a circular waveguide system with a small diaphragm, see for instance [23]. This situation seems to be out of the current SPP theory. In the frame of our theory, it can also be said that EOT through periodic arrays of either holes or slits are just particular cases. It must be mentioned that other authors also support this point of view using different arguments [24], [25].

The purpose of this contribution is to summarize the essential features of the impedance matching model and to provide more insight into the possibilities of such model. This will be done by performing a parametric study of the EOT as a function of the geometry of the unit cell and the holes. The influence of the geometry on the values of the components of the electric circuit used to simulate the phenomenon in the real system will be explored. It will also be discussed the addition of dielectric layers (such as those present in the original experiments) and how material losses can be introduced. This is particularly relevant because the influence of losses is very important for extraordinary transmission operation conditions, in contrast to what happens when holes are not electrically small.

2. Circuit Model for Thick Lossless Screens

The extraordinary transmission problem is represented in Fig. 1(a). A flat planar screen with thickness t is perforated with a periodic array of holes (in this case, rectangular holes to simplify mode matching computations, but the shape of the holes can be arbitrary). A uniform transverse electromagnetic (TEM) planar wave with the electric field linearly polarized along the y direction normally impinges on the screen and yields a reflected and a transmitted beam with

the same polarization. There is a single reflected/transmitted beam if the wavelength of the incident field is equal or larger than the period along the direction of the polarization, i.e., $\lambda \geq a_y$. Otherwise the situation complicates due to the appearance of grating lobes (however this is not the situation usually treated in the literature on the topic). The first idea behind the use of the impedance matching concept to explain extraordinary transmission is that the original periodic problem can be replaced by a single unit cell problem, such as that illustrated in Fig. 1(b).

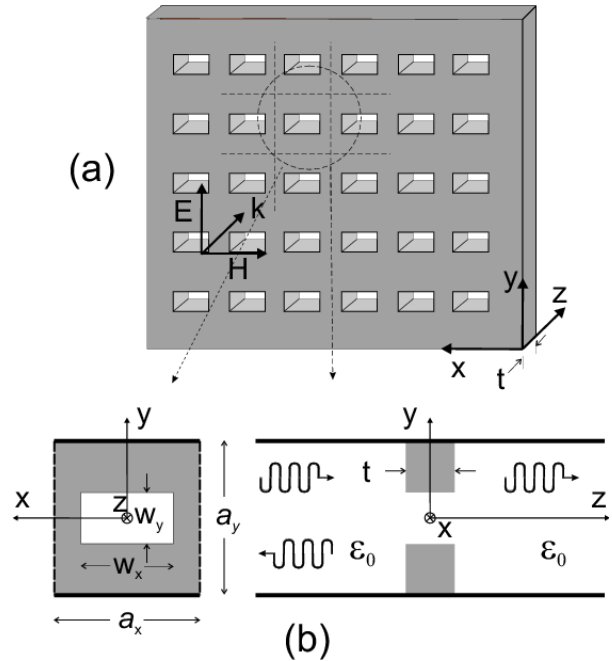

Fig. 1. (a) A portion of a periodically perforated metal screen. (b) The equivalent structure corresponding to a single cell under normal incidence conditions. In the waveguide, horizontal solid lines stand for “Electric walls” and vertical dashed lines for “Magnetic walls”.

This concept has also been used, for instance, by M. Beruete et al. [26] to perform the simulations of simple and stacked perforated plates, making some important observations about the nature of the fields at the extraordinary transmission frequency. The substitution of the periodic structure by its unit cell is possible because the fields inside the structure depicted in Fig. 1(b) are identical to the fields of the periodic system. The difference with the original problem is that the situation in Fig. 1(b) is better seen as the scattering of the TEM mode supported by a parallel plate waveguide when a thick diaphragm is placed inside the waveguide. In this situation, *regular* transmission is expected when $2W_x \geq a_y$ (this is the regular operation of frequency selective surfaces, FSS), but if there appears some transmission peaks for $2W_x \leq a_y$, this phenomenon can be considered somehow as “extraordinary” (in the sense that, to the authors’ knowledge, it was not reported in the past).

Following the theory in [17], [18], an equivalent circuit can be developed for the situation shown in Fig. 1(b). The most general circuit proposed in [18], which takes into

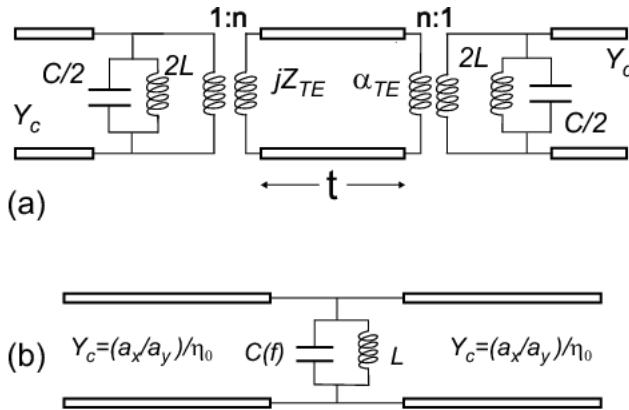

Fig. 2. Equivalent circuit to compute the scattering parameters for the TEM mode in the structure shown in Fig. 1(b).

account very subtle details of the transmission spectrum, is shown in Fig. 2(a).

There are two important features of the simulated phenomenon that are incorporated in the model in Fig. 2(a). The first feature is that only one higher-order mode of the TE-type modes is relevant to account for magnetic energy stored inside the hole (mode TE_{10} for square/rectangular holes, TE_{11} for cylindrical holes). This mode gives place to the evanescent-type transmission-line section depicted in Fig. 2(a). But there is a second point that is essential for extraordinary transmission, namely, the frequency dependence of the capacitance C appearing at both sides of the model for the discontinuity in Fig. 2(a). This capacitance accounts for the electrical energy stored around the diaphragm (and outside the hole) by higher-order TM modes supported by the unit cell parallel plate waveguide associated with the free-space region in Fig. 1(b). The contribution of these modes to C is almost frequency independent for operation frequencies corresponding to wavelengths meaningfully larger than the period of the structure. However, when the free-space wavelength of the impinging wave approaches the period a_y , a strong dependence on frequency is expected from conventional waveguide theory. Fortunately, this dependence is controlled by a single mode, the TM_{02} mode of the parallel plate waveguide, which is the TM mode with the lowest cutoff frequency that can be supported by the structure under symmetrical excitation. This means that the frequency dependent capacitance has the following form:

$$C(f) = C_0 + \frac{A_{TM_{02}}}{2\pi\eta_0\sqrt{(f_c^{TM_{02}})^2 - f^2}} \quad (1)$$

where $\eta_0 = \sqrt{\mu_0/\epsilon_0}$, $f_c^{TM_{02}}$ is the cutoff frequency of the mode TM_{02} and f is the operation frequency. The constant $A_{TM_{02}}$ gives the relative amplitude of the TM_{02} mode in comparison with other TM modes.

The key point in (1) is that $C(f)$ steadily increases up to infinity at the cutoff of the TM_{02} . Thus at that frequency the circuit model predicts a zero transmission point because the capacitance will behave as a short circuit. This is what,

in the frame of the theory of gratings, is called a Rayleigh-Wood anomaly. For a couple of frequency values below (but close to) the first Rayleigh-Wood anomaly frequency, the circuit model predicts two total transmission peaks (assuming the structure is lossless). These peaks correspond to what some researchers call EOT. They are present provided that the thickness of the screen is not too large. For very thin screens the model can be greatly simplified because the contribution of the region inside the hole is not important. The equivalent circuit for very thin screens is given in Fig. 2(b). This geometry is very convenient to study how the different geometric parameters of the unit cell affect the values of the capacitance, C , and inductance, L (which are both related to the fields outside the hole). The study of the behavior of those parameters is enough to understand the simplest system exhibiting extraordinary transmission. The next section is devoted to the analysis of this question.

2.1 Influence of Some Geometric Parameters

This section will analyze the influence of the geometric parameters on the transmission behavior of the perforated screen as well as on the values of the parameters of the circuit model. Although this analysis is not pretended to be very exhaustive, it will be enough to extract some important qualitative conclusions. In order to simplify the analysis, we will consider a rather thin screen and, therefore, the simplified circuit model in Fig. 2(b) is the relevant one. The influence of the thickness is explained in detail in [18], where the presence of two instead of only one transmission peaks is revealed and the evolution of those peaks as a function of the screen thickness is explained.

Let us then concentrate here on the influence of the transverse size of the hole. To begin with, it will be considered a square 2D lattice of rectangular slots practiced on a very thin screen. The period of the structure is $a_x = a_y = 5$ mm, the thickness of the screen is $t = 0.2$ mm and the slot width along the y direction is $W_y = 0.5$ mm. In particular we are interested in the study of the influence of the horizontal size of the slot (W_x) on the total transmission frequency/wavelength. This study is shown in Fig. 3. Conventional theory of FSS's says that the finite-length slot resonates at some frequency below the frequency for which $W_x = \lambda/2$ (i.e., the resonance wavelength is expected to be slightly larger than $2W_x$). This rough theoretical prediction ($\lambda_{res} = 2W_x$) has been included as a dashed grey straight line in Fig. 3 for comparison purposes. If the rough approximation was corrected to account for the edge effects of the short-circuit slot we could obtain the correct curve for values of $W_x \gtrsim 2.5$ mm. However, the total transmission frequency is far apart the dashed grey straight line for smaller values of W_x . For these values the total transmission frequency is governed by the periodicity ($\lambda_{res} \approx a_y$). This is the region of values of W_x for which the term *extraordinary* is properly used. It is interesting to compare this curve with the curves in [27, Fig. 3]. In that figure the authors plotted the measured and simulated (full-wave) extraordinary transmission wave-

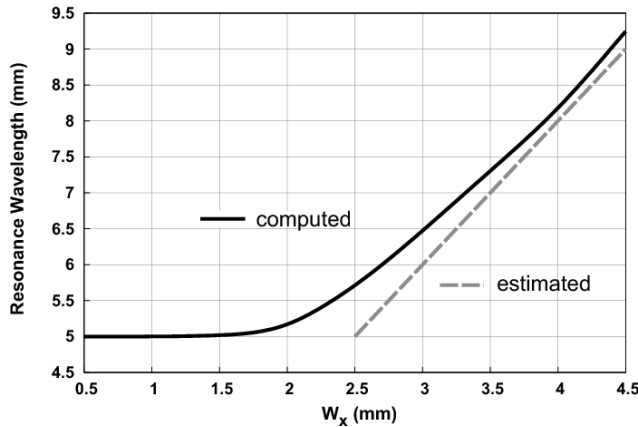

Fig. 3. The black solid line is the computed resonance wavelength (total transmission wavelength) for a 2D square lattice of rectangular holes practiced on a perfect conducting screen with the following dimensions: $t = 0.2$ mm, $a_x = a_y = 5.0$ mm, and $W_y = 0.5$ mm. The grey dashed line is the theoretical approximate curve given by $\lambda_{\text{res}} = 2W_x$.

lengths for a periodic structure fabricated with annular holes (i.e., the hole can be seen as a short section of coaxial cable operating in its first TE mode —TEM mode cannot be excited due to symmetry considerations—). The maximum transmission wavelength is plotted against the period keeping unchanged the size of the hole. Thus that figure does not exactly provides the same information as our Fig. 3. However, it is clear that SPP theory predictions correlate with measurements/simulations in the range of values of the period where the size ratio of the hole and the period is small. This corresponds with the horizontal part of the solid black curve in Fig. 3. For smaller periods it is the size of the hole what controls EOT wavelength. This is consistent with the part of our solid black curve in Fig. 3 having a slope near to 2. However it seems that the authors of [27] have not used the adequate expression for the dispersion equation of SPP's when the holes are relatively large. If the exact expression for this dispersion equation was used we should recognize that the results of our model and the results of the SPP theory would be closer to each other (it seems that the use of unappropriate dispersion relations for relatively large holes is a relatively frequent mistake in the literature on the topic).

In Fig. 4 the size of the hole and the periodicity along the y direction have been fixed in order to study the effect of varying the periodicity along the x direction. Since the size of the hole has been chosen large enough, the total transmission (resonance) wavelength is expected to be mainly controlled by the dimensions of the slot. This is more or less what happens in the range of values $4 < a_x(\text{mm}) < 6$ (see the grey curve in Fig. 4(b)). Note that the resonance wavelength is controlled by the product of the values of C and L in our simplified circuit model. From the full-wave simulations at a few low frequencies it is easy to extract the values of L and C . These values are plotted in Fig. 4(b). We can see that the resonance wavelength is more or less independent of a_x

because of the compensation of the values of C and L (see [18]). In general, shorter values of a_x imply larger inductance and smaller capacitance. Although it is the product of those parameters what determines the resonance wavelength, the actual value of L is also relevant. This is a very important issue if losses are taken into consideration, as it will be briefly discussed in next section (apart from consequences on bandwidth).

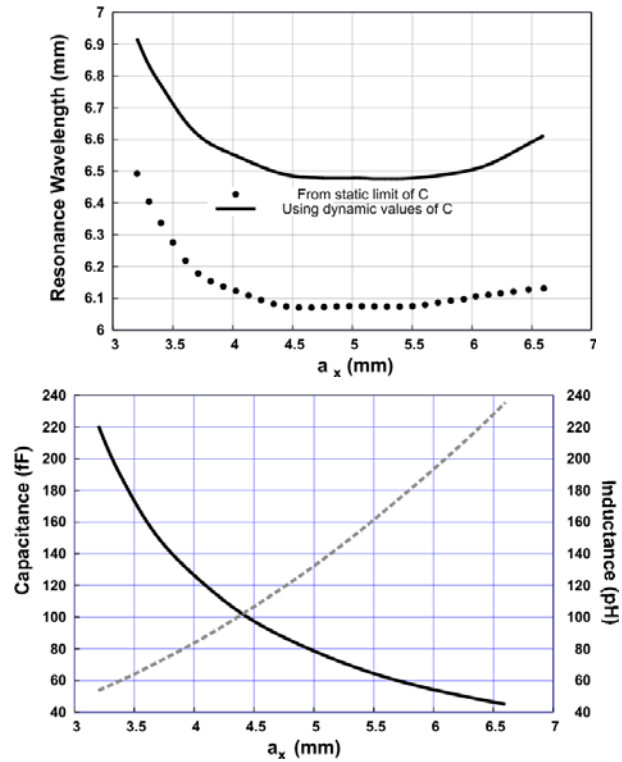

Fig. 4. (a) The solid black curve is the computed resonance wavelength (total transmission wavelength) versus a_x for a 2D square lattice of rectangular holes practiced on a perfect conducting screen with the following dimensions: $t = 0.2$ mm, $a_y = 5.0$ mm, $W_y = 0.5$ mm, and $W_x = 3.0$ mm. The black circles are the resonance wavelengths computed from the low frequency (static) value of C . (b) Inductance (solid black) and capacitance (dashed grey) of the simplified circuit model.

The increasing of the resonance wavelength at low values of a_x is associated with a faster increasing of L that cannot be compensated by the decreasing of C . The slight increasing of the resonance wavelength for $a_x > 6.0$ mm can be linked to the onset of the mode TE_{20} at $\lambda = a_x$. It is worthy to note that simple qualitative quasi-static considerations are also consistent with this behavior. Thus, in Fig. 4(a) we have included a plot with the predictions of the model using quasi-static values of C (that is, ignoring the frequency dependent contribution to C). The black points follow qualitatively the correct curve with a systematic shift due to the suppression of the dynamic contribution. This means that the evolution of λ_{res} with a_x can be explained from quasi-static arguments.

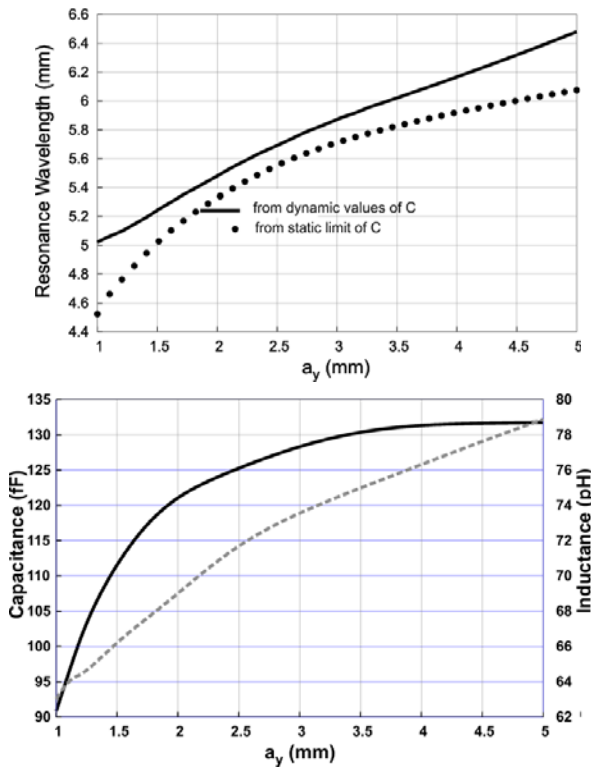

Fig. 5. (a) The solid black curve is the computed resonance wavelength (total transmission wavelength) versus a_y for a 2D square lattice of rectangular holes practiced on a perfect conducting screen with the following dimensions: $t = 0.2$ mm, $a_x = 5.0$ mm, $W_y = 0.5$ mm, and $W_x = 3.0$ mm. The black circles are the resonance wavelengths computed from the low frequency (static) values of C . (b) Inductance (solid black) and capacitance (dashed grey) of the simplified circuit model.

In Fig. 5 the results of a similar study to that carried out in Fig. 4 are shown. This new plot shows the influence of the period along the y direction (a_y) when keeping constant the size of the hole and a_x . The resonance or total transmission wavelengths are plotted in Fig. 5(a). The solid black curve is the exact full-wave calculation and the black circles are associated with the results obtained when the quasi-static value of C is taken. Once again (excepting a slight difference for small and large values of a_y), the quasi-static value of the capacitance seems to be very predictive. The values of the parameters C and L of the equivalent circuit are represented in Fig. 5(b). The inductance is very sensitive to a_y when the y period is small but remains almost constant for $a_y \gtrsim 3.5$ mm. However the capacitance is almost a linear function of a_y with two different slopes below and above $a_y \approx 2.5$ mm.

3. Extensions of the Model

Up to now it has been shown that our circuit-like model is very satisfactory to explain the reflected/transmitted spectra of thin/thick perforated screens of perfectly conducting metals. However, the applicability of the model is still limited since it does not cover some important realistic situations such as the presence of dielectric layers and/or con-

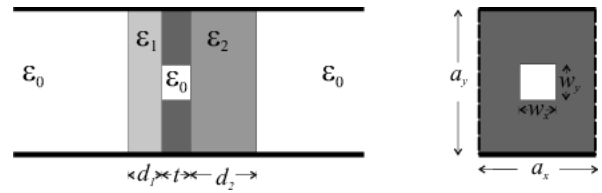

Fig. 6. Longitudinal and frontal views of the unit cell corresponding to a perforated perfect conductor screen sandwiched between two dielectric layers.

ductor losses. In this section we will discuss two significant modifications of the structure under analysis and how to account for those modifications without losing the simplicity of the model.

3.1 The Effect of Dielectric Layers

The first modification of the structure in Fig.1 that will be discussed is the presence of dielectric layers in the system. Although free standing perforated thick metal screens can be fabricated and have been used for microwave/millimeter wave experiments, the most usual situation corresponds to the case of a perforated thin metal film deposited on some transparent dielectric material (this is the situation for high frequencies of course; for instance, Au or Ag over fused quartz). Indeed, the original experiments [2] were carried out using a silver thin film 200 nm thick deposited over a quartz substrate. The influence of dielectric layers at one or two sides of the perforated metal screen has been the object of an in-depth theoretical study in [28] motivated by the potential applications of such structure. Thus, the inclusion of dielectric layers in our model would be useful because of two different reasons: a) many structures used in experiments make use of a supporting dielectric slab and, b) adding dielectric layers allows for control on the transmission spectrum if practical applications are envisaged. The exhaustive analysis of a sandwiched perforated structure reported in [28] (a perforated perfect conducting screen embedded between two slabs of equal/different dielectric materials having equal/different thicknesses) explains why the transmission spectrum for this configuration is much richer than the transmission spectrum observed in free standing metal surfaces. The qualitative reason is that, apart from the Floquet modes that can be supported by the perforated screen, additional surface waves associated with the presence of dielectric slabs take part in the phenomenon.

Our challenge now is how to extend the equivalent circuit model to the above situation. In order to illustrate our proposal let us consider the sandwiched structure treated in [28]. Following the same rational as in Sec. 2 the unit cell for that structure is shown in Fig. 6. For the representation of impinging, reflected, and transmitted TEM mode we use conventional transmission lines, such as those shown in Fig. 7(a) (where, at each section, it must be used the appropriate characteristic admittances corresponding to the free space or the dielectric). However, the presence of the dielectric slabs makes it rather complicated to figure out how to

substitute the effect of the higher-order modes scattered by the diaphragm using capacitances and/or inductances. Fortunately, frequency-dependent lumped admittances can still be used to account for higher-order mode effects. For slab thicknesses in the order of those considered in [28] it is reasonable to use a lumped capacitance to account for higher-order TM modes, $C_{TM_{ho}}^1$ (higher than the first one), and a lumped inductance for higher-order TE modes, $L_{TE_{ho}}^1$ (higher than the first one), in the region outside of the hole. For the region inside the hole, which is electrically small, the TE_{10} mode is the only mode to be retained; a lumped inductive π -circuit is used here instead of the distributed model in Fig. 2(a), but this is not important. The TM and TE modes with the lowest cutoff frequency should be treated in a different manner. For these modes we propose to use the input impedances and admittances, $jX_{TE_{02}}^r$ and $jB_{TM_{02}}^r$, corresponding to the transmission lines connections shown in Fig. 7(b).

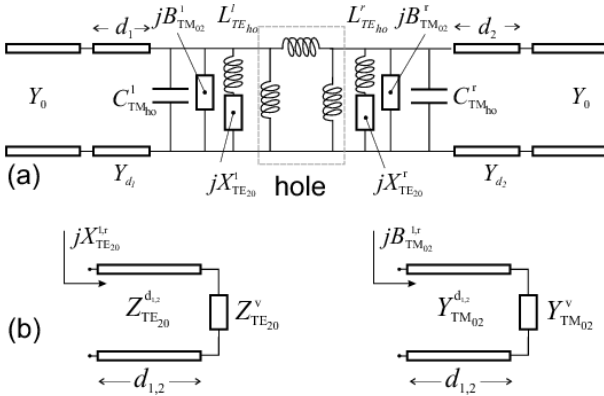

Fig. 7. (a) Circuit model for the unit cell shown in Fig. 6. (b) Distributed circuits giving the new impedances and admittances included in (a) to account for the modifications of the first higher order modes due to the presence of dielectric layers.

Although an *a priori* estimation of the total transmission (EOT) and total reflection (Rayleigh-Wood anomalies) is not now as obvious as for the free standing screen, it is clear again that resonances and antiresonances of the reactive part of the discontinuity will be associated with the above mentioned critical frequencies. This point of view is completely consistent with that adopted in [28], but the availability of an equivalent circuit makes easier the interpretation of the results and also any further design (apart from giving the possibility of developing semi-analytical formulas such as those reported in [19]). Just as an example to check the possibilities of this model, we have considered an EOT structure made of a thin metal screen with periodically perforated circular small holes deposited over a relatively thick quartz substrate. The structure has been simulated using the commercial software HFSS and the computed transmission coefficient has been plotted in Fig. 8. The susceptance associated to TM modes (namely, $B(\omega) = \omega C_{TM_{ho}}^r + B_{TM_{02}}^r$ in the circuit of Fig. 7(a)) is plotted in the same graph. Our theory predicts that transmission zeros are expected at the frequency values corresponding to the poles of this susceptance. More-

over, provided the inductance is small (as it happens for the case treated in this example, where the radius of the circular hole is electrically small), a transmission peak should appear just below the transmission zero. These predictions are fully corroborated by the curves plotted in Fig. 8. The slight frequency shift between the $|S_{12}|$ and the $B(\omega)$ curves can be attributed either to rough estimation of the parameters involved in our circuit model or to inaccuracies inherent to the numerical computation based on a finite elements code. Although more situations must be checked to validate our proposed model, our preliminary results seem to be rather satisfactory.

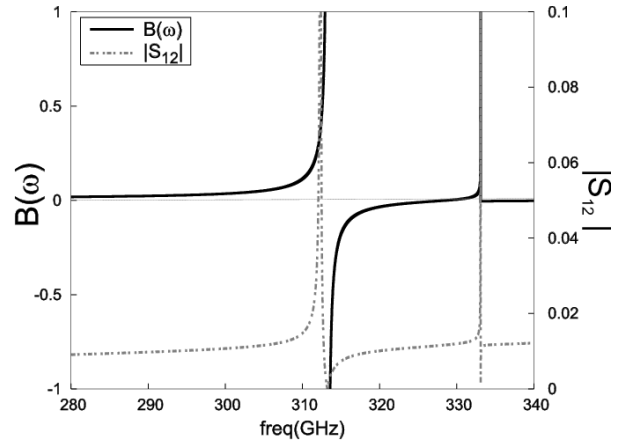

Fig. 8. Solid black line: Magnitude of the transmission coefficient, $|S_{12}|$, for an EOT structure (see Fig. 6) consisting of a square lattice of small circular holes (radius = 0.2 mm) in a thin perfect conductor ($t = 0$ mm) screen deposited over a slab of fused quartz ($\epsilon_{r2} = 2.13$). Data: $a_x = a_y = 0.9$ mm; $d_2 = 0.1$ mm (thickness of the quartz layer), $d_1 = 0$ mm. Commercial electromagnetic solver HFSS has been used for these computations. Dashed grey line: Normalized susceptance of the higher order TM modes computed using our circuit model and some rough estimations of its parameters.

3.2 The Effect of Losses

A potential significant penetration of the electromagnetic field into the material used to build the perforated screen should also be accounted for by our equivalent circuit model. At optical frequencies both magnetic and electric fields penetrate inside the conductor due to the plasma-like behavior of metals at such frequencies. Certainly, this is the main difference between working at optical frequencies and at microwave-to-THz frequencies. In this paper only losses in the latter case will be considered; namely at frequencies below THz where metals work under the skin effect regime. In this case, only the magnetic field inside the conductor is relevant but the additional inductance associated with the magnetic field penetration is not very important when compared with the inductance associated with TE modes. But surface currents are responsible for losses which could be important if currents are important too.

In the study of frequency selective surfaces operation, ohmic losses are considered by the engineers due to practi-

cal implications but they are not meaningful from the point of view of the phenomenology. In other words, most of the impinging power is either transmitted or reflected and only a small fraction is dissipated in the screen as ohmic losses. The physical reason that explains the relatively low level of losses in those systems is that the surface current on the metal screen is not very large. In the frame of our equivalent circuit model, this surface current is connected with the current intensity flowing in the LC tank circuit in Fig. 2(b). For electrically large holes, such as those used in FSSs, the inductance is relatively large and the capacitance relatively small. Trivial circuit theory reveals that currents will be rather small in such case even at resonance conditions. If ohmic losses are present they can be phenomenologically included in the model in the form of a series resistance connected with the inductance, for example. Obviously, this resistance will not depend on the current level. Thus, if the current level is kept low, ohmic losses will also be low. This is the case for usual FSS operation but not what happens at EOT operation conditions. In this latter situation, the resonance conditions involve values of L and C that can be very different from those found in regular FSS operation. Previously it was discussed that despite the low value of L associated with small holes, resonant transmission is possible below the cutoff of the first TM mode because C can reach very large values. Thus, at true EOT operation, L is much smaller and C is much greater than for regular FSS operation. It implies that, at resonance, current flowing in the LC tank is very large and high losses can be expected. More precisely, if we assume that losses can be included with a resistance, R , which is series connected to the inductance, L , of the circuit in Fig. 2(b), the impedance of the tank resonator at resonance can be written as

$$Z_{\text{res}} = \sqrt{\frac{L}{C}} \left[\frac{\sqrt{L/C}}{R} - j \right]. \quad (2)$$

For lossless materials, $R = 0$ and the impedance is infinite. Thus perfect total transmission is expected. For $R \neq 0$ but small (the case for good conductors), the impedance can still be large thus allowing almost perfect transmission, but losses will increase if $\sqrt{L/C}$ decreases (if almost total transmission is expected the voltage applied to the LC circuit is the same for any set of parameters L , C and R). Indeed, for typical EOT operation conditions, $\sqrt{L/C}$ might be much smaller than for regular FSS operation, which leads to two relevant consequences. The first one is that absorption in the screen is much larger than that expected in FSS problems, since currents are significantly higher. The second consequence is that the shunt impedance of the LC resonator might be of the same order of magnitude that the characteristic impedances of the transmission lines modeling the free space region, in such a way that important reflection is still present at the theoretical total transmission frequency (i.e., total transmission is not possible). Thus, if the holes are actually small, transmission peaks can be observed but important levels of absorption and reflection will remain. Published experiments do not report on the reflection coef-

ficient but we would expect relevant reflection levels when the transmission peak is very close to the Rayleigh-Wood's anomaly. Nevertheless, low reflection could be achieved while still operating in the EOT regime provided that the theoretical total transmission frequency is not too close to the Rayleigh-Wood's anomaly.

4. Conclusions

This paper has presented an overview of a new approach to the extraordinary optical transmission phenomenon that has been exhaustively studied within the optics community. It is shown how conventional tools employed for decades by microwave practitioners can satisfactorily account for the most fine details of this phenomenon. The influence of the geometry of the holes on the electrical parameters of our model has been studied and the results show that very intuitive ideas of electrostatics, magnetostatics, and circuit theory can be used to advance the behavior of such parameters. Finally, a couple of important problems connected with the transmission of electromagnetic waves through perforated screens have been addressed: presence of dielectric layers and material losses on the screen. Even in these latter cases, conventional circuit theory still provides a deep physical insight.

Acknowledgements

The authors acknowledge financial support of Spanish Ministry of Science and Innovation and European Union Feder funds (projects TEC2007-65376 and project Consolider Ingenio 2010, Engineering Metamaterials, CSD2008-00066).

References

- [1] BETHE, H. A. Theory of diffraction by small holes. *Phys. Rev.*, 1944, vol. 66, no. 7/8, p. 163 - 182.
- [2] EBBESEN, T. W., LEZEC, H. J., GHAEMI, H. F., THIO, T., WOLFF, P. A. Extraordinary optical transmission through subwavelength hole arrays. *Nature*, 1998, vol. 391, p. 667 - 669.
- [3] GHAEMI, H. F., THIO, T., GRUPP, D. E., EBBESEN, T. W., LEZEC, H. J. Surface plasmons enhance optical transmission through subwavelength holes. *Phys. Rev. B*, 1998, vol. 58, no. 11, p. 6779 - 6782.
- [4] BERUETE, M., SOROLLA, M., CAMPILLO, I., DOLADO, J. S., MARTIN-MORENO, L., BRAVO-ABAD, J., GARCIA-VIDAL, F. J. Enhanced millimeter-wave transmission through subwavelength hole arrays. *Optics Letters*, 2004, vol. 29, no. 21, p. 2500 - 2502.
- [5] BERUETE, M., SOROLLA, M., CAMPILLO, I., DOLADO, J. S., MARTIN-MORENO, L., BRAVO-ABAD, J., GARCIA-VIDAL, F. J. Enhanced millimeter wave transmission through quasioptical subwavelength perforated plates. *IEEE Transactions on Antennas and Propagation*, 2005, vol. 53, no. 6, p. 1897 - 1903.

- [6] GARCIA-DE-ABAJO, F. J., Colloquium: Light scattering by particle and hole arrays. *Rev. Modern Phys.*, 2007, vol. 79, p. 1267 - 1290.
- [7] GENET, C., EBBESEN, T. W. Light in tiny holes. *Nature*, 2007, vol. 445, p. 39 - 46, Jan. 2007.
- [8] PENDRY, J. B., MARTIN-MORENO, L., GARCIA-VIDAL, F. J. Mimicking surface plasmons with structured surfaces. *Science*, 2004, vol. 305, p. 847 - 848.
- [9] GARCIA-DE-ABAJO, F. J., SAENZ, J. J. Electromagnetic surface modes in structured perfect-conductor surfaces. *Phys. Rev. Lett.*, 2005, vol. 95, p. 233901 - (1-4).
- [10] CUTLER, C. C. Electromagnetic waves guided by corrugated conducting surfaces. Bell Telephone Labs. Report MM-44-160-218, October, 1944.
- [11] ELLIOTT, R. S. On the theory of corrugated plane surfaces. *IRE Trans. Antennas and Propagat.*, 1954, vol. 2, no. 2, p. 71 - 81.
- [12] COLLIN, R. E. *Field Theory of Guided Waves*. IEEE Press, 1971.
- [13] BARNES, W. L., DEREUX, A., EBBESEN, T. W. Surface plasmon subwavelength optics. *Nature*, 2003, vol. 424, p. 824 - 830.
- [14] WILLIAMS, C. R., ANDREWS, S. R., MAIER, S. A., FERNANDEZ-DOMINGUEZ, A. I., MARTIN-MORENO, L., GARCIA-VIDAL, F. J. Highly confined guiding of terahertz surface plasmon polaritons on structured metal surfaces. *Nature Photonics*, 2008, vol. 2, p. 175 - 179.
- [15] LOCKYEAR, M. J., HIBBINS, A. P., SAMBLES, J. R. Microwave surface-plasmon-like modes on thin metamaterials. *Physical Review Letters*, 2009, vol. 102, p. 073901(1-4).
- [16] MATSUI, T., AGRAWAL, A., NAHATA, A., VARDENY, Z.V. Transmission resonances through aperiodic arrays of subwavelength apertures. *Nature*, 2007, vol. 446, p. 517 - 521.
- [17] MEDINA, F., MESA, F., MARQUES, R. Equivalent circuit model to explain extraordinary transmission. In *Int. Microwave Symposium, IMS-2008*. Atlanta (GA, USA), 2008, p. 213 - 216.
- [18] MEDINA, F., MESA, F., MARQUES, R. Extraordinary transmission through arrays of electrically small holes from a circuit theory perspective. *IEEE Transactions on Microwave Theory and Techniques*, 2008, vol. 56, no. 12, p. 3108 - 3120.
- [19] MARQUES, R., MESA, F., JELINEK, L., MEDINA, F. Analytical theory of extraordinary transmission through metallic diffraction screens perforated by small holes. *Optics Express*, 2009, vol. 17, no. 7, p. 5571 - 5579.
- [20] SKIGIN, D. C., DEPINE, R. A. Transmission resonances of metallic compound gratings with subwavelength slits. *Physical Review Letters*, 2005, vol. 95, p. 217402(1-4).
- [21] MEDINA, F., SKIGIN, D. C., MESA, F. Extraordinary transmission through slits from a microwave engineering perspective. In *Proc. of the 38th European Microwave Conference*. Amsterdam (The Netherlands), 2008, p. 702 - 705.
- [22] MEDINA, F., MESA, F., SKIGIN, D. C. Extraordinary transmission through arrays of slits: a circuit theory model. submitted to *IEEE Transactions on Microwave Theory and Techniques*, 2009.
- [23] MEDINA, F., RUIZ-CRUZ, J. A., MESA, F., REBOLLAR, J., MONTEJO-GARAI, J.R., MARQUES, R. Extraordinary transmission without surface plasmons. submitted to *Phys. Rev. Lett.*, 2009.
- [24] KIRILENKO, A. A., PEROV, A. O. On the common nature of the enhanced and resonance transmission through the periodical set of holes. *IEEE Transactions on Antennas and Propagation*, 2008, vol. 56, no. 10, p. 3210 - 3216.
- [25] PANG, Y., NONE, A. N., SO, P. P. M., GORDON, R. Total optical transmission through a small hole in a metal waveguide screen. *Optics Express*, 2009, vol. 17, no. 6, p. 4433 - 4441.
- [26] BERUETE, M., CAMPILLO, I., NAVARRO-CIA, M., FALCONE, F., SOROLLA, M. Molding left- or right-handed metamaterials by stacked cutoff metallic hole arrays. *IEEE Transactions on Antennas and Propagation*, 2007, vol. 55, no. 6, p. 1514 - 1521.
- [27] KOFKE, M. J., WALDECK, D. H., FAKHRAAI, Z., IP, S., WALKER, G. C. The effect of periodicity on the extraordinary optical transmission of annular aperture arrays. *Applied Physics Letters*, 2009, vol. 94, p. 023104.
- [28] LOMAKIN, V., MICHIELSSEN, E. Enhanced transmission through metallic plates perforated by arrays of subwavelength holes and sandwiched between dielectric slabs. *Physical Rev. B*, 2005, vol. 71, p. 235117(1-10).

About Authors ...

Francisco MEDINA was born in Puerto Real (Cádiz, Spain), in November 1960. He received the Licenciado (M.Sc.) and Ph.D. degrees from the University of Seville, Seville, Spain, in 1983 and 1987, respectively, both in physics. From 1986 to 1987, he spent the academic year with the Laboratoire de Microondes de l'ENSEEIH (Toulouse, France) under supervision of Prof. Henri Baudrand. From 1985 to 1989, he was an assistant professor with the Department of Electronics and Electromagnetism, University of Seville, where, since 1990, he has been an associate professor in electromagnetism. He is currently head of the Microwave Group. His research interest includes analytical and numerical methods for guiding, resonant, and radiating structures, passive planar circuits, periodic structures, and the influence of anisotropic materials (including microwave ferrites) on such systems. He is also interested in artificial media modeling and design. He is on the editorial board of the International Journal of RF and Microwave Computer-Aided Engineering and is a reviewer of about 30 different journals IEEE, Institution of Electrical Engineers (IEE), U.K., and American Physics Society journals, among others. He has been a member of the technical programme committees (TPC) of several international and national conferences and has organized a few conferences and workshops. Dr. Medina is a fellow of the Massachusetts Institute of Technology (MIT) Electromagnetics Academy.

Francisco MESA was born in Cádiz (Spain), in April 1965. He received the Licenciado (M.Sc.) and Ph.D. degrees from the University of Seville (Seville, Spain), in 1989 and 1991, respectively, both in physics. He is currently an associate professor with the Department of Applied Physics 1, University of Seville, Seville, Spain. His research interests focus on electromagnetic propagation/radiation in planar structures and artificial electromagnetic materials.

Raúl RODRIGUEZ-BERRAL was born in Casariche (Seville, Spain), in August 1978. He received the Licenciado (M.Sc.) degree in Physics from the University of Seville (Seville, Spain), in 2001 and the Ph.D. degree from the same university and also in physics in June 2008. In January 2002, he joined the Department of Applied Physics 1, University of Seville, where he is currently an assistant professor. His research interest includes the study of the spectrum of periodic and non-periodic planar structures and high-frequency microstrip circuit modeling.