



Università degli studi di Ferrara

DOTTORATO DI RICERCA IN
“FISICA”

CICLO XXIII

COORDINATORE PROF. FILIPPO FRONTERA

**Bose-Einstein Condensates in the
Electro-Weak Sector
and General Treatment of
Primordial Perturbations**

Settore Scientifico Disciplinare: FIS/02

DOTTORANDA:
Angela Lepidi

TUTORE:
Prof. Alexander Dolgov

CO-TUTORE:
Prof. David Langlois

ANNI 2008/2010

A coloro che hanno raddrizzato la schiena e deciso di andare avanti.
Nonostante tutto.

Abstract

In the first part of this thesis, the possible realization of Bose-Einstein condensates in the early universe is analyzed. It is shown that, in the broken phase of the electroweak theory, W bosons may condense and form a ferromagnetic state with aligned spins. In this case the primeval plasma may be spontaneously magnetized inside macroscopically large domains and form magnetic fields which may act as seeds for the observed today galactic and intergalactic fields. Screening effects, due to the dense and hot primeval plasma, may turn the system into an antiferromagnetic one. To analyze the medium impact, electrodynamics of charged condensed bosons and spin $1/2$ fermions is studied at non-zero temperature and chemical potentials. The Debye screening length, the plasma frequency, and the photon dispersion relation are calculated.

In the second part of this thesis a general formalism, that provides a systematic computation of the linear and non-linear perturbations for an arbitrary number of cosmological fluids in the early Universe, is presented. Various transitions are considered, in particular the decay of some species. Using this formalism, the question of isocurvature non-Gaussianities in the mixed inflaton-curvaton scenario is revisited. It is shown that one can obtain significant non-Gaussianities dominated by the isocurvature mode while satisfying the present constraints on the isocurvature contribution in the observed power spectrum. Two-curvaton scenarios are also studied, taking into account the production of dark matter. Cases in which significant non-Gaussianities can be produced are investigated.

Abstract

Nella prima parte di questa tesi viene analizzata la possibilità che si formino dei condensati di Bose-Einstein nell'universo primordiale. Viene dimostrato che, nella fase rotta della teoria elettro-debole, i bosoni W possono condensare e formare uno stato ferromagnetico con spin allineati. Di conseguenza, il plasma primordiale potrebbe magnetizzarsi spontaneamente all'interno di domini di dimensione macroscopica. Questo meccanismo permette di generare in maniera spontanea dei campi magnetici primordiali che potrebbero essere all'origine di quelli che vengono osservati oggi su scala galattica e intergalattica.

Dal momento che il plasma primordiale ha temperatura e densità elevate, gli effetti di screening nel mezzo potrebbero mutare la natura del sistema rendendolo anti-ferromagnetico. In questa tesi viene presentata l'analisi degli effetti legati alla presenza del mezzo in elettrodinamica in presenza di un condensato di bosoni scalari carichi e fermioni con spin $1/2$. Vengono inclusi temperatura finita e potenziali chimici non nulli per le specie in esame. In particolare, vengono calcolate la lunghezza di screening di Debye, la frequenza di plasma e in generale la relazione di dispersione del fotone.

Nella seconda parte di questa tesi viene presentato un formalismo generale che permette di calcolare in maniera sistematica le perturbazioni lineari e non lineari per un numero arbitrario di fluidi cosmologici nell'universo primordiale. Vengono prese in esame diversi tipi di transizione, con particolare riferimento al decadimento di diverse specie. Con l'aiuto di questo formalismo vengono analizzate le non-Gaussianità di isocurvatura prodotte in un modello misto inflatone-curvatone. Viene dimostrato che si possono ottenere non-Gaussianità significative dominate dal modo di isocurvatura e nel contempo soddisfare i limiti attuali sullo spettro di isocurvatura. Vengono anche considerati modelli con due curvatoni e produzione di materia oscura. Vengono infine analizzati i casi in cui si ottengono non-Gaussianità significative.

Abstract

Dans la première partie de cette thèse, nous analysons la possible réalisation de condensats de Bose-Einstein dans l'univers primordial. Nous montrons que, dans la phase brisée de la théorie électrofaible, les bosons W peuvent condenser et former un état ferromagnétique où les spins sont alignés. Dans ce cas, le plasma primitif peut devenir spontanément magnétique dans des régions macroscopiques et donner lieu à des champs magnétiques qui pourraient être à l'origine de ceux galactiques et extragalactiques observés aujourd'hui. Des effets d'écrantage, dus au plasma primitif chaud et dense, peuvent transformer le système en un système antiferromagnétique. Afin d'analyser l'impact moyen, nous étudions l'électrodynamique des condensats de bosons chargés et des fermions de spin $1/2$ à température et à potentiels chimiques finis. La longueur de Debye, la fréquence du plasma et la relation de dispersion des photons sont calculées. Dans la seconde partie de cette thèse, nous présentons un formalisme général permettant un calcul systématique des perturbations linéaires et non linéaires pour un nombre arbitraire de fluides cosmologiques dans l'univers primordial. Plusieurs transitions, et en particulier la désintégration de certaines espèces, sont prises en compte. À l'aide de ce formalisme, nous revisitions la question des non-gaussianités d'isocourbure dans le scénario mixte inflaton-curvaton. Nous montrons qu'il est possible d'obtenir des non-gaussianités non négligeables dominées par le mode isocourbe tout en respectant les contraintes actuelles sur la contribution de l'isocourbure au spectre de puissance observé. Nous étudions également des scénarios mettant en jeu deux curvatons en prenant en compte la production de matière noire. Les cas où des non-gaussianités non négligeables peuvent être produites sont examinés.

Contents

Contents	v
Introduction	1
I Bose-Einstein condensates at the electro-weak phase transition.	5
1 Bose-Einstein condensation	6
1.1 Introduction	6
1.2 Formation of the Bose-Einstein condensate.	8
1.2.1 Kinetic approach	10
1.3 The electro-weak symmetry	12
1.3.1 Spontaneous symmetry breaking	13
1.3.2 The electro-weak phase transition	15
1.3.3 Sphalerons	16
1.4 The condensation of W bosons in the primordial universe	18
1.4.1 Lepton asymmetry - cosmological bounds	20
1.4.2 Generation of a large lepton asymmetry	22
1.5 Screening in plasma	24
2 Ferromagnetic properties of vector boson condensate	27
2.1 Equations of motion of gauge bosons and their condensation.	27
2.2 Spin-spin interactions of W bosons	31
2.2.1 Electromagnetic interactions	32
2.2.2 Quartic self-coupling of W	34
2.2.3 Z -boson exchange	35
2.2.4 Plasma screening	35
2.3 Magnetic properties of BECs	38
2.4 Discussion of the results	41

3	Condensate in plasma: medium effects	44
3.1	Perturbative calculations of the photon polarization operator	45
3.2	Photon propagation in plasma	49
3.3	Electrodynamics with BEC	52
3.3.1	Calculations in another gauge	55
3.4	Friedel oscillations in fermionic plasma	56
3.5	Screening in bosonic plasma	62
3.5.1	Contribution from poles	63
3.5.2	Contribution from the integral along the imaginary axis	64
3.5.3	Contribution from the logarithmic branch cuts	65
3.6	Discussion of the results	71
II Primordial perturbations and non-Gaussianities.		74
4	Perturbations: the state of the art	75
4.1	Introduction	75
4.2	Inflation	77
4.2.1	Generation of cosmological perturbations	78
4.3	Non linear perturbations	80
4.3.1	Curvature perturbation	81
4.3.2	Adiabatic, isocurvature and number perturbations	83
4.4	From theory towards observations	85
4.4.1	Power spectrum	86
4.4.2	Bispectrum	87
4.5	Observational bounds on non-Adiabaticity	88
4.6	Non-Gaussianities	90
4.7	The curvaton scenario	91
5	Evolution of perturbations	96
5.1	Decay	97
5.1.1	Before the decay	97
5.1.2	After the decay	98
5.1.3	Several transitions	99
5.2	Scenario with a single curvaton	100
5.2.1	Perturbations after the decay	100
5.2.2	Primordial adiabatic and isocurvature perturbations	102
5.2.3	Non-Gaussianities	103
5.3	Scenario with two curvatons	107

5.3.1	First order	107
5.3.2	Second order	109
5.3.3	Limit $\Lambda \ll 1$	111
5.3.4	Other limits	113
5.4	Discussion of the results	113
 Conclusions		 115
 A Equations of motion for the SM gauge bosons		 117
 B Correlation functions for several perturbations		 119
 C Second order coefficients for the model with two curvatons		 122
 Bibliography		 124

Introduction

In the 1960s and 1970s, the standard model of particle physics (SM) was developed. With the only exclusion of gravity, it describes successfully all the low-energy interactions between elementary particles, which are represented in terms of gauge interactions mediated by bosons, such as photon, W^\pm and Z^0 . The predictions of the SM have been tested experimentally and have resulted consistent with data to very high precision (e.g. within one part in 10^8 for electron-photon interactions).

In spite of its amazing successes, the SM is far to be an exhaustive theory. First of all, as we have said, it does not include gravity, while it would be highly desirable to have a complete theory including all the interactions. Second, although it is theoretically self-consistent and renormalizable, it has several unnatural properties giving rise to puzzles. For instance, there is no experimental evidence of CP breaking in chromodynamics (QCD), although there are natural terms in the QCD Lagrangian which are able to break the CP symmetry (strong CP problem). Another puzzle is the so called hierarchy problem. That is, there are quadratic divergences in the Higgs mass arising from loop computations, which can be cancelled by a very precise fine tuning of the fermion-Yukawa and the quartic scalar coupling constants. But such a precise fine tuning (up to one part in 10^{17}) does not seem very natural. Finally, it should be mentioned that the SM has a high number of free parameters (19 without considering neutrino interactions), which are chosen to fit the experimental data but can not be derived from first principles. Besides theoretical problems, the SM has a phenomenological shortcoming, since it does not predict neutrino oscillations, which are now well established and are related to non-vanishing masses of neutrinos.

At the beginning of the 1970s, when the SM was being developed with the invaluable help of data from accelerators, I. B. Zeldovich used to say that the universe is the poor man's accelerator. There, experiments do not need to be funded and built: all we have to do is to observe, take data and interpret them. Actually, the universe is the only possible "laboratory" where energies as high as 10^{10} GeV can be reached. Hence, it is the only place where we can study very high energy phenomena.

In the last years, the basic features of the universe have been determined: it is spatially flat, accelerating and its composition has been determined with high accuracy. It was found that ordinary matter (baryons) only constitutes a small fraction of the total energy content, about 4,5%. Concerning the rest, about 23% is made of some form of matter which is revealed through gravitational effects, but is undetectable by emitted or scattered electromagnetic radiation. This is the so called *dark matter*. The

largest part of the energy content of our universe, about 72%, is accounted for in terms of a hypothetical form of energy, which makes the universe accelerating. This is the so called *dark energy*.

In this sense, cosmology shows another limit of the SM, since the latter does not contain any viable dark matter candidate, which should possess all the properties deduced from observational cosmology.

As we have said, the universe is very flat and homogeneous, at least on large scales. Together with some other striking properties, these features find a natural explanation within a theory which became one of the fundamental ingredients of modern cosmology: inflation. Inflation is a phase of rapid and accelerated expansion which took place in the very early stages of the universe evolution. Besides solving the flatness and the homogeneity puzzles, inflation naturally enables the production of primordial perturbations, which can act as seeds for the observed cosmic structures. In spite of the simplicity of the basic models, the details of inflation and of the related production of primordial perturbations are still unclear and a lot of models have been proposed and studied. The primordial perturbations left an imprint on the cosmic microwave background of photons in the form of tiny temperature fluctuations, which are being observed today. A lot of data are being collected, which are helping to discriminate among the plenty of possible models. This is why inflation and the related production of primordial perturbations are hot topics in modern cosmology.

Another open issue in particle physics, which requires some help from cosmology and vice versa, is the formation of the baryon asymmetry which we observe today and that enables our world to exist. Since there is no baryon number violation at low energy, what we think today is that the excess of baryons over anti-baryons was produced at some point in the early universe evolution. A lot of possible solutions have been proposed, which are often based on the extensions of the SM (e.g. SUSY theories) and sometimes implement the physics of massive neutrinos or of the early universe (e.g. the inflaton, that is a scalar field which is supposed to drive inflation). Nevertheless, none of them is universally accepted as "the" one and, how it is commonly said, having a lot of solutions to a single problem means that the problem has not been solved.

For all the reasons listed above, it is evident that we need models for physics going beyond the standard one and that one of the best places to test such models is the early universe. On the other hand, to deal with the early universe, we need to understand the high energy behavior of particles and their interactions. This is why it is interesting to merge informations and ideas from the two fields.

This thesis is devoted to the study of some problems for which the combination of informations from cosmology and particle physics is important. Emphasis is given to the original results achieved rather than to a complete pedagogical review on the subjects.

Being a student of the International Doctorate on AstroParticle Physics (IDAPP) program, I had the occasion to work in two different institutes: the University of Ferrara and the APC (AstroParticule et Cosmologie) center of the University of Paris 7 D. Diderot. As a consequence, this thesis is divided in two parts corresponding to the two different research projects.

The first part deals with Bose-Einstein condensates and their possible formation in the early universe, in particular around the electro-weak phase transition epoch. Bose-Einstein condensation is the quantum phenomenon of accumulation of identical bosons in their lowest energy state. Under these conditions they behave as a single macroscopic entity described by a coherent wave function rather than a collection of separate independent particles. In this thesis the impact of such a condensate on quantum field theories is analyzed in the framework of the SM.

An introduction to Bose-Einstein condensation is presented in chapter 1. There, it is shown that a condensate of W bosons could be formed in the early universe, around the electroweak symmetry breaking epoch. This would happen in the presence of a large lepton asymmetry. The conditions necessary for condensation are discussed together with their compatibility with the observational bounds.

Chapters 2 and 3 are devoted to the original results obtained in collaboration with A. Dolgov and G. Piccinelli. In chapter 2 it is shown that the condensed W s act as a ferromagnet, that is, it is energetically favorable for them to align their spins. This behavior results from the competition of two terms. The first of them is determined by the direct magnetic interaction of the spins and which favors their alignment, while the second arises from the local quartic interaction of W s and goes in the opposite direction. As a consequence, this ferromagnetic system may be changed into an anti-ferromagnetic one, where the spins are anti-aligned, when the relative strength of the two terms is changed. This could happen, for instance, due to medium effects or in non standard theories. If realized, the ferromagnetic state may lead to the spontaneous magnetization of the early universe.

In chapter 3 a Bose-Einstein condensate of scalar particles is considered as one of the components of a medium in which an electromagnetic interaction takes place. It is well known that the medium can have relevant effects on the interactions, especially in the presence of high temperatures and densities, such as the ones realized in the early universe. It is shown that the presence of the condensate has a dramatic impact on the photon polarization tensor, that becomes infrared singular. A detailed analysis of the singularities is performed and the impact on the electrostatic interactions is studied. It is shown that the Coulomb potential is changed into an oscillating and exponentially damped one, having several unusual properties.

The second part of this thesis deals with cosmological perturbations and the related

production of non-Gaussianities. A general introduction to the subject is presented in chapter 4, where theoretical tools as well as the present observational bounds are reviewed.

Chapter 5 deals with the results of the work done in collaboration with D. Langlois. There a unified treatment of linear and nonlinear perturbations is presented, which enables to compute their evolution through one or several cosmological transitions such as the decay of some particle species. Various decay products and their branching ratio are taken into account. As a consequence, this formalism can be applied to a large class of early Universe scenarios, in order to compute automatically their predictions for adiabatic and isocurvature perturbations, and their non-Gaussianities. As input, one simply needs parameters that depend on the homogeneous evolution. This provides a simple way to confront an early Universe scenario, and its underlying particle physics model, with the present and future cosmological data. As applications, scenarios with one or two curvatons are considered. In both examples, the results that have been obtained in previous works are generalized, allowing the curvaton to decay into several species.

Part I

**Bose-Einstein condensates at the
electro-weak phase transition.**

Chapter 1

Bose-Einstein condensation

1.1 Introduction

Bose-Einstein condensation is the quantum phenomenon of accumulation of identical bosons in the same state, which is their lowest energy (ideally zero momentum) state. It corresponds, at the macroscopic level, to the appearance of superfluidity. One of the striking features of condensed bosons is that they behave as a single macroscopic entity described by a coherent wave function rather than as a collection of separate independent particles.

The existence of Bose-Einstein condensation was predicted by Satyendra Nath Bose and Albert Einstein in 1924-25. Nevertheless, it took seventy years to make the first experimental observation, which was performed in a vapor of rubidium-87 atoms [1] and was awarded the 2001 Nobel Prize in Physics. Difficulties in performing this observation were created by the extremal conditions necessary for the condensation. Roughly, the Bose-Einstein condensate is realized when the inter-particle separation d is smaller than their de Broglie wavelength:

$$d < \lambda_{dB} \sim 2\pi/\sqrt{2mT}. \quad (1.1)$$

Such a condition can be satisfied by cooling the system down to a very low temperature, as it is done in laboratory experiments, or making the boson states "crowded", since $d \sim n^{-1/3}$, where n is the number density. The latter condition can be realized, for instance, when a large chemical potential is associated to the boson species.

Given the requirement of crowded quantum states, it is clear that bosons condense as long as their particle number is conserved. This is true independently of their spin. For instance, in this thesis we analyze in detail the condensation of the vector W boson as well as a generic scalar particle, having respectively spins 1 and 0. It is even possible to make photons condense in photon-number conserving systems, as it was recently

experimentally proven [2].

The peculiar features of BEC give rise to a lot of interesting physical phenomena. This is why, in the recent years, the study of BEC became an active area of research in different fields of physics, for instance plasma and statistical physics, for a review see book [3] and references therein. It is also possible that matter in the form of a BEC is present in astrophysical environments, for instance a condensate of scalar ${}^4\text{He}$ nuclei may be realized in white dwarf cores [4]. BECs could be also realized in the early phases of the universe evolution, as it is discussed below for W bosons.

W bosons may condense in the early universe both below and above the electro-weak phase transition if the cosmological lepton asymmetry happened to be sufficiently high, i.e. if the chemical potential of neutrinos was larger than the W boson mass at this temperature [5]. The condensation of vector bosons differs from the theoretically simpler case of scalar bosons, such as the ${}^4\text{He}$ nuclei, due to the presence of an additional degree of freedom, their spin states. In both cases, scalar and vector, the condensed bosons are in the zero momentum state but in the latter case the spins of the individual vector bosons can be either aligned or anti-aligned. These states are called respectively ferromagnetic and anti-ferromagnetic ones. In [6] the magnetic properties of a W -boson condensate are analyzed in detail and it is shown that the condensed W -bosons form a ferromagnetic state with aligned spins. This phenomenon may spontaneously generate primordial magnetic fields, which may act as seeds for the observed today galactic and intergalactic fields.

A recent application of vector BEC to astrophysics was studied in reference [7], where the condensation of deuterium nuclei was considered. The authors argue that the interaction between deuterium nuclei forces them into the lowest spin antiferromagnetic state. A detailed analysis of the phases of deuterium at densities higher than atomic, but lower than nuclear can be found in [8]. The authors found that, at very high densities, nuclear interactions dominate favoring a ferromagnetic state, while at lower densities a new phase is realized.

It is well known that the presence of a medium, instead of the vacuum, can have important consequences on the particle interactions. For instance, the screening of a test charge is a typical medium effect. If BECs are realized in the primordial plasma or in star cores, it is important to understand how they affect the interactions in such an environment. As an example, medium effects may change the ferromagnetic W boson system, that is discussed above, into an antiferromagnetic one.

Surprisingly, while medium effects have been extensively studied since the formulation of gauge field theories, the consequences of having a BEC component in such a medium were not considered till very recent times [9; 10; 11; 12; 13; 14]. In these papers the problem of electrodynamics of charged fermions and condensed scalar bosons was

considered. Condensation is induced through an asymmetry in the leptonic sector: if a lepton asymmetry resides on charged particles (e.g. the electrons), there must be a corresponding boson asymmetry to preserve the global electric charge neutrality of the system. When the fermion asymmetry reaches a certain critical value, such that the boson chemical potential has to be equal to the boson mass, the bosons condense.

In references [9; 10; 11] both the effects of condensate and finite temperature were considered in electrodynamics plus BEC of scalar particles. A perturbative approach was used to calculate the photon polarization tensor in such a plasma. As a result, it was found that the screening of impurities is essentially different from the case when the condensate is absent.

In [4; 12; 13; 14; 15] a similar problem was considered in the framework of an effective field theory. This formalism is complementary to the perturbative one and the results agree in overlapping areas. The authors focused on the applications to the astrophysics of the helium white dwarfs discussing possible condensation of helium nuclei and analyzing the thermodynamical properties of the system and possible observational signatures. A similar study, but generalized to the case when two different nuclei (Helium and Carbon) coexist in the same star, was done in [16].

1.2 Formation of the Bose-Einstein condensate.

In gauge field theories, it is convenient to describe formation of BEC using the kinetic theory approach. Let us consider a system of bosons and fermions in thermal equilibrium at temperature T . As is known, the equilibrium distribution functions of bosons (B) and fermions (F), up to the spin counting factor, are equal to:

$$f_{F,B} = \frac{1}{\exp[(E - \mu_{F,B})/T] \pm 1}, \quad (1.2)$$

where the signs plus and minus stand respectively for fermions and bosons and $\mu_{F,B}$ are the chemical potentials of particles. Evidently, the chemical potential of bosons cannot exceed their mass, $\mu_B \leq m_B$, otherwise their distribution would not be positive definite. This upper bound on μ_B enforces a phase transition when the asymmetry between bosons and anti-bosons is so high that even maximally large chemical potential, $\mu_B = m_B$, is not sufficient to provide for such a high asymmetry. At the microscopic level this phase transition coincides with the formation of a BEC. Hence the boson distribution function takes the form:

$$f_B = C\delta^{(3)}(\mathbf{p}) + \frac{1}{\exp[(E - m_B)/T] - 1}, \quad (1.3)$$

where the first delta-function term describes the condensate and a new constant parameter C is its amplitude. The second term, which is the usual Bose distribution, describes non-condensed particles and vanishes at $T = 0$. As it is evident from equation (1.3), the kinetic approach naturally enables to take finite temperature effects into account.

The fact that the boson distribution takes the form given in (1.3) can be demonstrated, for instance, by using the Heisenberg formalism for quantum operators - see [17]. Here we adopt an *a posteriori* approach: we assume the distribution (1.3) as given and demonstrate that it is an equilibrium one by using kinetic theory, that is, showing that it annihilates the collision integral.

The distribution in equation (1.3) is the stationary solution of the kinetic equation if and only if $\mu_B = m_B$ (or $\mu_{\bar{B}} = m_B$). When $C \neq 0$, it describes non-vanishing number density of bosons in a vanishingly small momentum interval near $q = 0$. In this sense, it can be interpreted as a classical field configuration $\phi(t) = \phi_0 \exp(im_B t)$, where the field amplitude is related to the condensate amplitude as $2\phi_0^2 m = C/(2\pi)^3$. On the other hand, it evidently can be interpreted as a collection of particles at rest.

Once the boson charge density \mathcal{J}_0^B is fixed, it is possible to calculate the critical temperature T_C , when the phase transition takes place and the Bose condensate is formed. This temperature can be calculated imposing

$$\mathcal{J}_0^B(\mu_B = m_B, C = 0) = \mathcal{J}_0^B(T_C), \quad (1.4)$$

where $\mathcal{J}_0(T_C) \equiv e\Delta n(T_C)$, being Δn the number density of particles minus antiparticles. In the limit $\mu \ll T$ and $m = 0$, one finds, for fermion and boson species having g degrees of freedom:

$$\begin{aligned} \Delta n_F &= \frac{g}{6} T^3 \left[\frac{\mu_F}{T} + \frac{1}{\pi^2} \left(\frac{\mu_F}{T} \right)^3 \right], & \text{(FERMIONS)} \\ \Delta n_B &= \frac{g}{3} T^3 \left[\frac{\mu_B}{T} - \frac{3}{2\pi^2} \left(\frac{\mu_B}{T} \right)^3 \right], & \text{(BOSONS)} \end{aligned} \quad (1.5)$$

that gives, at first order:

$$\mathcal{J}_0^B(T_C) \simeq \frac{e}{3} \mu_B T_C^2. \quad (1.6)$$

It follows that

$$T_C \simeq \sqrt{\frac{3\mathcal{J}_0^B(\mu_B = m_B, C = 0)}{e m_B}} \quad (1.7)$$

which coincides with what is presented in the literature - see e.g. reference [18].

1.2.1 Kinetic approach

To verify that the distributions f_F and f_B written above are the equilibrium ones, one can use a kinetic approach. The kinetic equation has the form:

$$\frac{df_1}{dt} = I_{coll}[f], \quad (1.8)$$

where the collision integral I_{coll} is equal to

$$I_{coll} = -\frac{(2\pi)^4}{2E_1} \int d\tau'_{in} d\tau_{fin} \delta^{(4)} \left(\sum p_{in} - \sum p_{fin} \right) |A_{if}|^2 F[f], \quad (1.9)$$

and

$$F[f] = \Pi f_{in}(1 \pm f_{fin}) - \Pi f_{fin}(1 \pm f_{in}). \quad (1.10)$$

In equation (1.9) $d\tau'_{in}$ is the phase space of all initial particles except for particle under scrutiny, i.e. the initial particle 1, $d\tau_{fin}$ is the phase space of all final particles, A_{if} is the amplitude of the transition from an initial to a final state. The product is taken over all initial (in) and final (fin) states and signs plus or minus stand for bosons and fermions respectively. It is straightforward to check that $F[f]$ vanishes on distributions (1.2) for arbitrary μ_F and $\mu_B \leq m_B$ satisfying the usual condition of chemical equilibrium:

$$\sum \mu_{in} = \sum \mu_{fin}. \quad (1.11)$$

If $\mu_B = m_B$, there arises an additional freedom that $F[f]$ vanishes for distribution (1.3) with an arbitrary C . The value of the latter is determined by the magnitude of the asymmetry between bosons and anti-bosons - see below. Notice that, in equilibrium, the chemical potentials of particles and antiparticles are opposite, $\bar{\mu} = -\mu$. Hence, if bosons condense with $\mu_B = m_B$, the anti-bosons cannot condense because $\mu_{\bar{B}} = -m_B$.

We assume above that the collision amplitude is T-invariant, but even if this restriction is lifted, the collision integral is still annihilated by functions (1.2) or (1.3) due to S-matrix unitarity [19].

Concerning the formation of the Bose-Einstein condensate, it is essential that the particles in question possess a conserved quantum number that forces their chemical potential to be non-vanishing, if the number of particles is not equal to the number of antiparticles. The amplitude C is then calculated from the known difference of the number densities of particles and antiparticles.

For the models discussed in this thesis, the conserved quantum number is the electric charge, since we consider electrically charged bosons and induce their condensation through an asymmetry in the leptonic sector. When this asymmetry resides on charged

leptons, bosons must have a non vanishing chemical potential to preserve the global electric charge neutrality of the system. Hence, if the asymmetry in the fermion sector is large enough, bosons condense.

We can express the amplitude of the condensate through the electric charge density of the plasma. We impose the condition that the total electric charge density of all the present species is zero. The condition of vanishing electric charge density may be not fulfilled e.g. in cosmology [20], but we postpone this case for future consideration. So we assume that the total electric charge is vanishing: $\mathcal{J}_0 = 0$. Expressed through the particle occupation numbers $f_{B,F}$ this condition reads:

$$\int d^3q \left[\sum_B g_B Q_B (f_B - \bar{f}_B) + \sum_F g_F Q_F (f_F - \bar{f}_F) \right] = 0, \quad (1.12)$$

which is valid for any plasma made of bosons (B) and fermions (F) having $g_{B,F}$ spin degrees of freedom and particle charges $Q_{B,F}$ (of course, antiparticles have charges $-Q_{B,F}$). Here we skipped the arguments of $f_{F,B}$.

To conclude, the amplitude of the Bose condensate C for globally neutral plasma is equal to:

$$C = -4\pi \int dq q^2 \left[\sum_B g_B Q_B \left(f_B(E_B, \mu_B, T) - \bar{f}_B(E_B, -\mu_B, T) \right) + \sum_F g_F Q_F \left(f_F(E_F, \mu_F, T) - \bar{f}_F(E_F, -\mu_F, T) \right) \right] \quad (1.13)$$

Here $E_{B,F} = \sqrt{m_{B,F}^2 + q^2}$ and $\mu_B = m_B$ for the condensed bosonic species. The magnitude of the fermionic chemical potential, μ_F , is determined by the charge density of fermions. For instance, for a model containing one scalar boson with charge +1 and one spinor fermion having charge -1, we have:

$$C = -4\pi \int dq q^2 \left[f_B(E_B, m_B, T) - \bar{f}_B(E_B, -m_B, T) - 2f_F(E_F, \mu_F, T) + 2\bar{f}_F(E_F, \mu_F, T) \right]. \quad (1.14)$$

The fermion chemical potential is assumed as a free parameter in the models considered in chapters 2 and 3. Nevertheless, when considering the realistic $SU(2) \times U(1)$ model in cosmology, the cosmological bounds on the lepton asymmetry of the universe must be taken into account - see discussion in section 1.4.1.

1.3 The electro-weak symmetry

The standard model of particle physics (SM) successfully describes the interactions between elementary particles with the exclusion of gravity. Dynamics, that is, interactions, naturally arise when using a locally symmetric lagrangian, that is, in gauge field theories. In particular, the SM lagrangian is invariant under the non-abelian symmetry group $SU(3) \times SU(2) \times U(1)$, where $SU(3)$ accounts for strong forces, while $SU(2) \times U(1)$ constitutes the weak sector. For a complete review on the subjects which are introduced in this section see [21; 22] and references therein.

Let us recall that the generators T_j (with $j = 1, \dots, N_G$) of a non-abelian group G obey, by definition, the commutation relations:

$$[T_i, T_j] = if_{ijk}T_k, \quad (1.15)$$

where f_{ijk} are called the structure constants of the group and are antisymmetric under interchange of any pair of indices. Let us consider the transformation of fields according to some representation of G . The generators T_j will be represented by $n \times n$ matrices L_j and the field transformation is specified by N_G parameters which we call θ_j and can be written as:

$$\phi \rightarrow \phi' = \exp^{-i\mathbf{L}\cdot\boldsymbol{\theta}} \phi, \quad (1.16)$$

where ϕ is a multiplet of fields

$$\phi = \begin{pmatrix} \phi_1 \\ \phi_2 \\ \vdots \\ \phi_n \end{pmatrix}. \quad (1.17)$$

Let us assume that the lagrangian is invariant under a global transformation $\mathcal{U}(\theta_j)$. If the parameters θ_j depend on the position x , the gradients contained in the lagrangian break the invariance at local level. This problem can be solved by substituting the standard derivatives with a covariant derivative having the property:

$$D_\mu\phi(x) \rightarrow D'_\mu\phi'(x) = \mathcal{U}(\theta)D_\mu\phi(x). \quad (1.18)$$

As long as all the gradients of the lagrangian are contained in the covariant derivative, the invariance under local non-abelian gauge transformations is ensured. If we introduce one vector field $W_\mu^j(x)$ for each generator of the group, we can write the covariant

derivative as:

$$D_\mu \phi(x) = [\partial_\mu + ig \mathbf{L} \cdot \mathbf{W}_\mu(x)] \phi(x), \quad (1.19)$$

where g plays the role of a coupling constant. Evidently this procedure introduces, in the free particle lagrangian, interactions mediated by the gauge boson $W_\mu^j(x)$.

1.3.1 Spontaneous symmetry breaking

The SM is a gauge theory based on the group $SU(3) \times SU(2) \times U(1)$. As it is clear by the number of generators of such a group, the SM contains twelve gauge bosons: the photon, the W^\pm , the Z^0 and eight gluons respectively for the electromagnetic, weak and strong interactions. But, while photons and gluons are massless, the weak bosons W^\pm and Z^0 have almost degenerate masses of order of 100 GeV. If we introduce such masses explicitly in the lagrangian, e.g. we break the symmetry of the model by an explicit mass term, the renormalizability of the theory is spoiled, since the high momentum limit of the propagator tends to a constant:

$$\frac{k_\mu k_\nu / m^2}{k^2 - m^2} \rightarrow \text{const}, \quad (1.20)$$

which leads to divergent terms. The way to generate the required masses while avoiding such a undesirable feature passes through the spontaneous breaking of the symmetry of the electro-weak gauge group, $SU(2) \times U(1)$. In spontaneously broken systems the ground state does not possess the same symmetry properties of the lagrangian. The spontaneous breakdown of a continuous symmetry in field theory implies the existence of massless spin-less particles (*Nambu-Goldstone bosons*), whose number is equal to the number of the broken generators [23]. It comes out that, when SSB occurs in a gauge theory involving massless vector fields and scalar fields, the Goldstone bosons disappear and re-emerge as the longitudinal mode of the vector fields, which therefore behave become massive particles (*Higgs phenomenon*). By using this mechanism it is possible to generate masses for the W and Z bosons without spoling renormalizability.

As an example, let us consider a simple lagrangian locally invariant under $U(1)$:

$$\mathcal{L} = -\frac{1}{4} F_{\mu\nu} F^{\mu\nu} + [(\partial_\mu - ieA_\mu) \phi^*][(\partial_\mu + ieA_\mu) \phi] - \mu^2 \phi \phi^* - \lambda(\phi \phi^*)^2. \quad (1.21)$$

Clearly, if we assume $\lambda > 0$ and $\mu^2 < 0$ there is a ring of degenerate ground states. The lagrangian (1.21) has in total four degrees of freedom (DOFs), two from the massless

vector boson and two from the scalar complex field. If we redefine the scalar field as:

$$\phi(x) = \frac{1}{\sqrt{2}} [v + \xi(x) + i\chi(x)] \quad v = \sqrt{\frac{-\mu^2}{\lambda}} \quad (1.22)$$

and substitute it in the lagrangian (1.21) we get:

$$\mathcal{L} = -\frac{1}{4}F_{\mu\nu}F^{\mu\nu} + \frac{e^2v^2}{2}A_\mu A^\mu + \frac{1}{2}(\partial_\mu\xi)^2 + \frac{1}{2}(\partial_\mu\chi)^2 - \lambda v^2\xi^2 + \dots, \quad (1.23)$$

which seems to describe the interactions of a massive vector field and two scalars. Since this lagrangian contains apparently five DOFs, one of them is clearly spurious and can be eliminated by choosing a particular gauge called the *U gauge*, in which the unphysical DOF is absorbed in the arbitrary field phase. In practice and for a $\mathcal{U}(1)$ gauge theory, since the parameter $\theta(x)$ can be arbitrarily chosen, we can set it equal to the phase of $\phi(x)$ at each space-time point, so that:

$$\phi'(x) = \exp^{-i\theta(x)} \phi(x) = \frac{1}{\sqrt{2}} [v + \eta(x)] \quad (1.24)$$

This way both ϕ' and η are real and the lagrangian becomes

$$\mathcal{L} = -\frac{1}{4}F'_{\mu\nu}F'^{\mu\nu} + \frac{e^2v^2}{2}A'_\mu A'^\mu + \frac{1}{2}(\partial_\mu\eta)^2 - \lambda v^2\eta^2 + \dots, \quad (1.25)$$

where

$$A'_\mu(x) = A_\mu(x) + \frac{1}{e}\partial_\mu\theta(x) \quad F'_{\mu\nu} = \partial_\mu A'_\nu - \partial_\nu A'_\mu. \quad (1.26)$$

This way \mathcal{L} describes the interactions of a massive vector boson A'_μ and a real scalar field η , called the *Higgs boson* with mass

$$m_\eta^2 = 2\lambda v^2 = -2\mu^2 \quad (1.27)$$

In conclusion, when a symmetry is spontaneously broken the gauge boson acquires a mass while the Goldstone boson disappears, leaving the Higgs boson as the only scalar field. The same mechanism is applied to the whole electro-weak group in the *Yang-Mills theories*.

It is worth stressing that symmetry breaking is one of the crucial points of the SM: weak and electromagnetic interactions are made different by the Higgs field, which breaks the symmetry among them. Without the Higgs, weak and electromagnetic interactions would be indistinguishable and the weak bosons, W and Z , would be massless.

1.3.2 The electro-weak phase transition

The idea of spontaneous symmetry breaking was extensively used in solid state physics before than in particle physics. For instance, such phenomena as ferromagnetism, superfluidity, superconductivity etc. can be described by a spontaneous symmetry breaking. In this sense, knowing the properties of solid state physics systems turned out very useful to study particle physics by analogy.

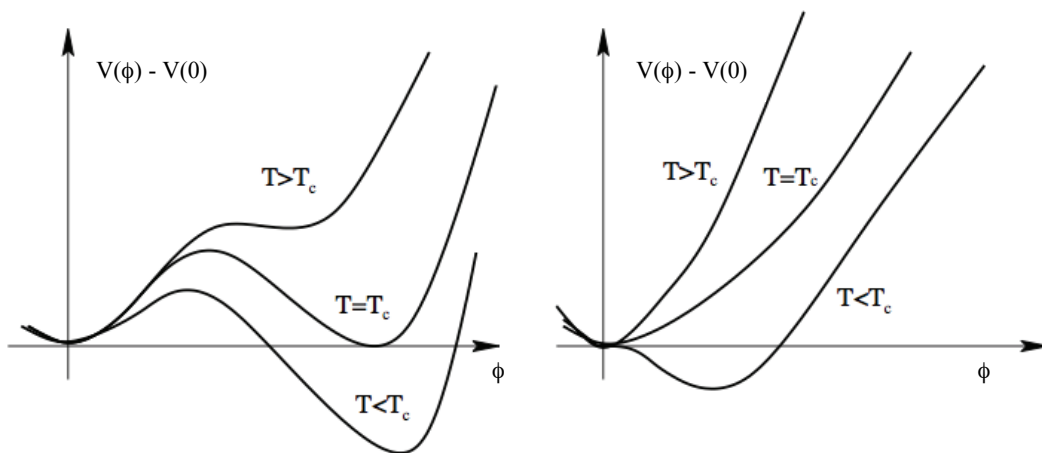

Figure 1.1: Behavior of the effective potential $V(\phi) - V(0)$ as a function of the order parameter ϕ in theories in which phase transitions are first order (left side) or second order (right side).

For instance, we know from our everyday life that thermodynamical conditions, such as temperature and pressure, can affect the properties of a physical system. Systems with spontaneously broken symmetries are not an exception. In solid state physics it was observed that heat can lead to the restoration of a broken symmetry. The associated phase transition can be first or second order, see figure 1.1. In the first case, during the phase transition, the effective potential has two local minima separated by a barrier, one corresponding to a stable state of the system and another to an unstable state. The phase transition happens through formation of bubbles of the new (stable) phase, which expand in the unstable one, as in boiling water. In a second order phase transition, instead, the order parameter ϕ decreases continuously to zero with rising temperature.

Analogously, as it was shown by Kirzhnits and Linde [25], the vacuum expectation value of the Higgs field, which is responsible for the E-W symmetry breaking, should disappear at high enough temperature, see [26] for a complete review. As a consequence, the electro-weak symmetry would be restored in the early universe, when such high temperatures were realized. This is called *electro-weak phase transition*.

In the SM framework, the critical temperature of the phase transition, T_c , is of order 100 GeV, and the transition should be second order for Higgs masses above 80 GeV [27].

In analogy with superconductivity, which can be destroyed by external fields and currents, the EW phase transition can be influenced by charge densities and currents. For instance, raising density of matter can lead to symmetry restoration in theories with only charged currents [28], see also [26], in analogy with superconductive phenomena. Roughly, this happens because, if we consider a fermion ψ interacting with a scalar field ϕ , the energy of the fermion is proportional to $\phi\langle\bar{\psi}\psi\rangle$. As a consequence, increasing the density of fermions, $\langle\bar{\psi}\gamma_0\psi\rangle$, makes the states with $\phi \neq 0$ energetically unfavorable.

On the contrary, in the presence of neutral currents, symmetry restoration is inhibited in the presence of sufficiently high fermion densities [5]. This point is discussed in detail in section 1.4 for the EW sector of the SM.

1.3.3 Sphalerons

Baryon and lepton numbers are conserved in the SM at the classical level, that is, the associated classical currents J^μ are conserved:

$$\partial_\mu J_B^\mu = \partial_\mu J_L^\mu = 0. \tag{1.28}$$

The conservation law written above is violated at the quantum level for global symmetries as a consequence of the Adler-Bell-Jackiw (ABJ) anomaly [29]. An anomaly is the failure of a classical symmetry of the lagrangian \mathcal{L} to survive the process of quantization and regularization. If we have a classic symmetry, the transformation $\phi \rightarrow \phi + \delta\phi$ will leave the action $S(\phi)$ invariant, while, if we have a quantum symmetry, the same transformation will leave the path integral $\int D\phi e^{iS(\phi)}$ invariant, where $D\phi$ is the measure. Therefore it looks reasonable that some classic symmetries may be not valid in quantum theories. On the other hand, local gauge symmetries are always associated to conserved quantities, think for instance of the electric charge.

Because of quantum corrections, the divergence of both the baryon and lepton currents is non vanishing in the SM, at least for some field configurations.

By making explicit calculations, it comes out that the two divergences are equal besides a numerical factor: the divergence of the baryon (fermion) current is proportional to the number of quark (lepton) families [30]. As a consequence, as long as the model contains the same number of quark and lepton families (e.g. the SM has three of both) $B - L$ is conserved rather than B and L separately. Of course, this is true as long as the special field configurations, which make the divergence of the currents non vanishing, are realized. Otherwise, the two currents would be automatically conserved.

An example of such a special field configuration is the $SU(2)$ instanton at low tem-

perature. In the broken phase of non-Abelian gauge theories there are topologically different vacua separated by a barrier. If the temperature is smaller than the height of the potential barrier, there may be transitions via tunneling from a vacuum state to another, characterized by different baryon numbers. The field configuration in this case is called instanton.

It was shown by 't Hooft that the rate of baryon number violation by instanton effects is suppressed by a factor $\exp(-16\pi^2/g^2) \simeq 10^{-170}$, where $g = 0.637$ [31]. This leads to practically unobservable effects, for instance the proton lifetime for decay through instanton channel has been estimated to be larger than the age of the universe by orders of magnitude.

However, the situation is different at high enough temperature, when thermal fluctuations can take the field over the barrier, making it pass from one state to another in a classic way, without tunneling [32]. In this case the static solution of the field equations is called a *sphaleron*. The latter is a classical field configuration, in the sense that its Compton wavelength is much smaller than its size.

The energy of such a sphaleron, corresponding to the height of the barrier between the vacuum states, is given by:

$$E^s = \frac{2m_W(T)}{\alpha_W} f(c.c.), \quad (1.29)$$

where m_W is the mass of the W boson, $\alpha_W = \alpha/\sin^2\theta_W \simeq 1/30$, f is a function of the coupling constants (c.c.) of the SM and takes values of order unity in the model with the doublet Higgs field. At $T \rightarrow 0$, when $m_W \sim 80$ GeV, it follows that $E^s \sim 10$ TeV.

If sphalerons are in thermal equilibrium, their number density, that is related to the probability of baryon number violating transitions, is proportional to the Boltzmann suppression factor $\exp(-E^s/T)$. The latter decreases with increasing temperatures because of the $1/T$ factor in the exponential and the reduction in m_W due to the decrease of the Higgs condensate. Formally, above the EW symmetry restoration, $E^s = 0$ because the Higgs condensate disappears. Actually, due to the medium effects, the W boson acquires a temperature dependent magnetic mass $\sim \alpha_W T$, that is anyway not sufficient to suppress the equilibrium sphaleron rate at high temperature.

As a consequence, the processes with baryon number non-conservation would not be suppressed at very high temperature and consequently any $B + L$ asymmetry would be erased. Actually, the rate of production of coherent classical field states in the collisions of elementary particles is a complicated problem. For the symmetric phase, the rate of the transitions is not calculable by any perturbative method. The only way to address such a problem is to use parametrical estimates and numerical lattice calculations, for a detailed discussion on this point see e.g [33].

1.4 The condensation of W bosons in the primordial universe

In this section the conditions for the condensation of bosons are analyzed and their possible realization in the primordial universe is discussed.

We focus in particular on the condensation of W -bosons, that was first considered in the pioneering papers [5], where the broken electroweak sector was studied at zero temperature. In the cited papers it was argued that, at sufficiently high leptonic chemical potential, a classical W_j boson field could be created in the early universe.

In what follows we consider a simple example of electrically neutral plasma where charged W -bosons condense because of a large asymmetry between leptons and antileptons. For simplicity we confine ourselves to only one family of leptons. This simplification does not influence the essential features of the result. A more detailed analysis with all the particles included can be found in reference [34]. Quarks may be essential for the imposing of the condition of vanishing of all the gauge charge densities in plasma and for the related cancellation of the axial anomaly but we work in the lowest order of the perturbation theory where the anomaly is absent.

The plasma is supposed to be electrically neutral, with zero baryonic number density but with a high leptonic one. The essential reactions are the direct and inverse decays of W :



The equilibrium with respect to these processes imposes the equality between the chemical potentials:

$$\mu_W = \mu_\nu - \mu_e \quad (1.31)$$

The condition of electroneutrality reads:

$$n_{W^+} - n_{W^-} - n_{e^-} + n_{e^+} = 0, \quad (1.32)$$

while the leptonic number density is equal to

$$n_L = n_\nu - n_{\bar{\nu}} + n_{e^-} - n_{e^+}. \quad (1.33)$$

Here $n = g_s \int d^3p / (2\pi)^3 f$ is the number density of the corresponding particles and g_s is the spin counting factor. One should remember that only left-handed electrons participate in reaction (1.30), chirality is conserved in reactions with Z -bosons and

photons, while chirality flip may take place only in reactions with Higgs bosons.

Leptonic number is supposed to be conserved, so n_L is constant in the comoving volume and is a fixed parameter of the scenario. (B+L)-nonconservation induced by sphalerons is neglected because temperature is mostly assumed to be below the electroweak phase transition.

It is evident that for sufficiently high n_L the chemical potential of W should reach its maximum value, $\mu_W = m_W$, and with further rising n_L , W -bosons must condense. In particular, the condensate is formed when the critical lepton number density, n_ν^c , is reached.

As we wrote in section 1.1, the formation of a Bose condensate takes place when the de Broglie wavelength $\lambda_{dB} \sim 2\pi/\sqrt{2mT}$ is equal or larger than the inter-particle separation. Hence we can use this simple criterion to roughly check whether the conditions to create a condensate are realized or not.

Let us first assume that the density of leptonic charge is very large, $n_L > T^3$. Correspondingly the amplitude of the condensate must also be large, $n_W^C \approx C/(2\pi)^3 > T^3$. In this case $\mu_{e,\nu} > m_W$ and equations (1.31–1.33) can be easily solved:

$$\mu_\nu \approx \mu_e \quad n_L \approx \frac{\mu_\nu^3}{2\pi^2}, \quad \text{and} \quad n_W^C \approx \frac{2}{3} n_L. \quad (1.34)$$

According to the equilibrium distribution (1.3) the plasma would consist of two parts, the condensate with zero momentum and the high temperature plasma over the condensate. Interparticle separation of the non condensed W -bosons under these conditions is $d \sim n_L^{-1/3} < T^{-1}$, while the de Broglie wave length of the condensed W 's with zero momentum is formally infinitely large. In the realistic condensate the particle momentum is not precisely zero but is of the order of the inverse size, r^{-1} , of the region where W -bosons condense. The de Broglie wave length of W -bosons above the condensate, $\lambda_{dB} \sim 2\pi/\sqrt{2mT}$ is thus larger than d as long as $T < m_W/2\pi^2$.

For instance, $n_L \gg T^3$, could be created in the Affleck-Dine scenario, see section 1.4.2. In this model the universe could be quite cold. Later, when $n_L \sim 1/a^3$ is diluted by the cosmological expansion down to the value when μ_W becomes smaller than m_W the condensate would evaporate and the universe would be reheated.

Though the possibility of a huge lepton asymmetry is quite interesting, the condensation of W -bosons could take place even with much smaller $n_L \sim m_W^3$. The interparticle separation of W -bosons under these conditions is $d \sim n_L^{-1/3} \sim m_W^{-1}$. The de Broglie wavelength of the high temperature plasma would be again $\lambda_{dB} \sim 2\pi/\sqrt{2mT}$, that is larger than d as long as $T < 2\pi^2 m_W$. As is argued above, the de Broglie wave length of the condensed W -bosons even in this case is much larger than the interparticle distance.

At $T \sim m_W$ the charged weak bosons, W , condense if all the relevant quantities are

close by an order of magnitude to the W -boson mass to a proper power, i.e. $\mu_\nu \sim \mu_e \sim m_W$, $n_L \sim m_W^3$. They rise with rising temperature, as can be found from numerical solution of equations (1.31–1.33).

More rigorous calculations of the critical number density necessary for condensation can be found in the literature, see [35; 36; 37; 38] where the general equations are presented, together with some critical discussion on the approximations used. It is also shown that an analytic solution is possible only in some special limits and that the approximations used are not valid in some regions of parameters.

For instance, the critical total leptonic chemical potential below the EW symmetry breaking in the low temperature limit, $T \rightarrow 0$, is [35; 36]:

$$\mu_L^c \simeq m_W + \frac{T^2}{65 \text{ GeV}}. \quad (1.35)$$

At high temperature, that is T much larger than masses and chemical potentials but smaller than the EW breaking value, W -bosons would condense at

$$\mu_L^c = 0.3\sqrt{T^2 - T_c^2}, \quad (1.36)$$

where $T_c \sim 200 \text{ GeV}$ [36].

The W -boson mass, m_W , approaches its usual vacuum value created by the Higgs condensate when $T \rightarrow 0$. But when the temperature rises, it changes because of two opposite effects. The first one is the usual positive temperature correction $\delta m_W \sim eT$. The second effect is negative and is related to a decrease of the amplitude of the Higgs condensate. As a result, at temperatures above the electroweak phase transition, when the Higgs condensate disappears [25], the sole contribution to W -mass comes from the temperature corrections [39] and m_W may be much smaller than its vacuum value determined by the Higgs condensate.

Hence the W mass in the electroweak symmetric phase might be lower than in the broken phase and a lower lepton asymmetry would be required for the condensation. In this thesis we mostly assume that the temperature is below the electroweak phase transition and thus the plasma consists of massive W and Z bosons, neutral Higgs bosons, quarks, leptons, and their antiparticles. Nevertheless the interesting possibility of W condensation at lower lepton asymmetry should be kept in mind.

1.4.1 Lepton asymmetry - cosmological bounds

As we have seen, a large lepton asymmetry is required to make W bosons condense in the early universe. Given the electrical neutrality of the universe, if such an asymmetry exists, it must necessarily reside in neutrinos.

Even though cosmological lepton asymmetry can not be directly measurable, its impact on big bang nucleosynthesis (BBN), CMB and large scale structure formation can be used to calculate constraints.

The most stringent bounds today come from BBN, since an asymmetry in the electronic neutrino is reflected into the primordial elements production through the weak reactions:

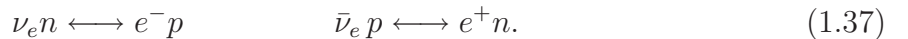

The other two neutrino species, muonic and tauonic, directly participate only through their impact on the universe cooling rate, that is typically parametrized through the effective number of neutrinos. Nevertheless, neutrinos are known to mix. Hence all flavors must have similar asymmetries at the BBN epoch [40; 41]:

$$-0.04 \leq \xi_\nu = \frac{\mu_\nu}{T} \leq 0.07. \qquad (1.38)$$

It should be noted that the entropy release from the electroweak epoch down to the BBN epoch diminishes the lepton asymmetry, n_L/n_γ , by the ratio of the particle species present in the cosmological plasma at these two epochs, which is approximately 10. Hence the original lepton asymmetry, $(n_L/n_\gamma)_{EW}$ could be of order unity and still compatible with BBN.

Nevertheless it should be noted that the stringent bounds at the BBN epoch given in equation (1.38) can not exclude a large primordial lepton asymmetry. It was shown in [42] that the previously quoted bounds apply when all initial asymmetries have the same sign. In this case there would be an approximate flavor equipartition. But, if two flavors have opposite asymmetries, the total impact on BBN would vanish. In this case the primordial lepton asymmetry would leave an imprint on the number of effective neutrinos, which may be detectable in future precision cosmological observations.

It should be also noted that in the early universe there could be mechanisms active to block neutrino oscillations, for instance the coupling to a hypothetical pseudogoldstone boson, Majoron [43].

To conclude, the formation of the W boson condensate is consistent with the present cosmological bounds on lepton asymmetry even in the broken phase of the EW sector, when an asymmetry as large as $n_L \geq m_W^3$ is required.

At high temperatures, when the Higgs condensate is underdeveloped, the W -boson mass may be noticeably smaller than the plasma temperature and W could condense even at $|\mu/T| \ll 1$, corresponding to $|\mu/T| \ll 0.07$ at BBN. If W s condensed above the electroweak phase transition, the magnitude of the chemical potential necessary for the condensation was much smaller than temperature, $\mu_W \sim gT$, as explained above.

As we see, in this case the chemical potentials of electrons and neutrinos would be also much smaller than temperature. In this limit the differences between number densities of fermions and anti-fermions, at first order in μ/T , are twice larger than the corresponding for bosons, as one can see from equations (1.5):

$$n_F - n_{\bar{F}} = \frac{1}{6} g_F \mu_F T^2, \quad (1.39)$$

where g_F is the number of the spin degrees of freedom, $g_e = 2$, $g_\nu = 1$.

Substituting this expression into equations (1.31–1.33) and assuming an arbitrary chemical potential $\mu_W < T$, we find that the condensate would be formed if approximately $n_L \geq gT^3$ and that all the chemical potentials are of the order of gT . Correspondingly the necessary lepton asymmetry could be as small as $n_L/n_\gamma \sim g$. We see that even without the entropy release such lepton asymmetry is not dangerous for BBN.

If the lepton asymmetry was generated above the EW phase transition, it might be transformed into the baryonic one by the sphaleron processes, creating unacceptably large baryon asymmetry. Nevertheless, lepton asymmetry could be generated in the broken EW phase. It should be noted that a mechanism to avoid the generation of too large baryon asymmetry is triggered by a large lepton asymmetry itself. This is discussed with some details in the following section.

1.4.2 Generation of a large lepton asymmetry

Baryogenesis is one of the open issues of modern cosmology. It is commonly believed that our universe is matter asymmetric, in the sense that there exists a tiny excess of matter over anti-matter. BBN [44] and CMB [45] data consistently indicate a local excess of baryons (B) over anti-baryons (\bar{B}), which is quantified as:

$$\eta = \frac{n_B - n_{\bar{B}}}{n_\gamma} \simeq 6 \cdot 10^{-10}, \quad (1.40)$$

where n_i are number densities of baryons, anti-baryons and photons (γ). Still, the details of how such an asymmetry was generated are not fully understood yet.

The SM contains all the ingredients required to produce a baryon asymmetry, that are the three Sakharov conditions: B and CP violating interactions and departure from thermal equilibrium [46]. Nevertheless, the amount of the CP violation is insufficient to account for the observed value of η .

Given that in several theoretical models, e.g. the SM at high temperature (see section 1.3.3) and most of Grand Unified Theories (GUTs), $B - L$ is conserved rather than B and L separately, one popular way to produce the baryon asymmetry is through partial or total conversion of a lepton asymmetry.

The usual theoretical attitude towards lepton asymmetry is that, since sphalerons should be effective before the EW phase transition, lepton and baryon cosmic asymmetries would be the same. Nevertheless, in theories with neutral currents, such as the SM, the presence of a large lepton asymmetry suppresses the EW symmetry restoration at high temperatures. This phenomenon was pointed out in reference [5] and confirmed in several subsequent papers [47; 48], see also [26].

As a consequence, sphalerons could be not fully efficient even in the early universe. Hence, even though the lepton asymmetry was generated at very high temperatures, when the EW symmetry would be normally restored, the baryon and lepton asymmetries equipartition could be not realized.

A lot of viable baryogenesis models have been proposed, for a review see e.g. [49] and references therein. Among them, models of generation of large lepton asymmetry were considered in references [47; 50; 51; 52].

One possibility to naturally produce lepton (or baryon) asymmetry of order unity is given by the popular Affleck-Dine (AD) mechanism [53]. The latter is based on the existence of flat directions in the potential of supersymmetric theories (SUSY), e.g. directions in which the potential vanishes. In SUSY ordinary quarks and leptons have boson partners, hence several scalar fields are naturally present. These scalar fields carry baryon and lepton number. A coherent field, i.e., a large classical value of such a field, can in principle carry a large amount of baryon or lepton number.

In the primordial universe, when $H \geq 100$ GeV, e.g. during inflation, the finite energy density breaks SUSY. Such a breaking can lift the flat directions from zero to finite energy. The superpotential for the scalar field ϕ in the minimal SUSY extension of the SM takes the form:

$$V(\phi) = (m_{3/2}^2 - cH^2) |\phi|^2 + \frac{|\lambda|^2}{M^{2(n-3)}} |\phi|^{2(n-1)} + \left(\frac{A\lambda + aH}{nM^{n-3}} \phi^n + h.c. \right). \quad (1.41)$$

where M is some large mass, generally assumed equal to the Planck or the GUT mass and $m_{3/2} \sim 10^2 - 10^3$ GeV. The A term is responsible for the baryon (or lepton) number violation. The parameters n , λ and A depend on the model and on which flat direction is lifted.

After the decay of both the condensate ϕ and the inflaton, an asymmetry for the $U(1)$ number carried by ϕ could be created, where the amount of the produced asymmetry is only slightly dependent on the model parameters. The baryon (or lepton) to entropy ratio can be roughly estimated as:

$$\frac{n_B}{s} \simeq \frac{n_B T_R}{\rho_I} \simeq \frac{n_B T_R \rho_\phi}{n_\phi m_\phi \rho_I}, \quad (1.42)$$

where T_R is the reheating temperature after the inflaton decay, while the fractional baryon number $n_B/n_\phi \sim 1$ must be calculated numerically. The ratio ρ_ϕ/ρ_I can be estimated analytically as:

$$\frac{\rho_\phi}{\rho_I} \simeq \left(\frac{m_{3/2} M^{n-3}}{\lambda M_{Pl}^{n-2}} \right)^{2/(n-2)}, \quad (1.43)$$

see the references quoted above for the details. Typically, the AD mechanism produces $n_{B(L)}/s$ of order 1, that would permit the condensation of W bosons in the early universe.

1.5 Screening in plasma

Being interested in applications to cosmology, when the primordial universe was dense and hot, it is important to consider the effects of medium in the physical problems addressed.

A typical and well known medium effect is screening of a an electric charge, Q . In plasma, the long-ranged Coulomb field generated by some test charge Q is transformed into the Yukawa type potential (see e.g. [39; 54]):

$$U(r) = \frac{Q}{4\pi r} \rightarrow \frac{Q \exp(-m_D r)}{4\pi r}, \quad (1.44)$$

where the Debye screening mass, m_D , is expressed through plasma temperature and chemical potentials of the charged particles. Physical interpretation of this result is evident: test charge polarizes plasma around, attracting opposite charge particles. As a consequence, the electrostatic field drops down exponentially faster than in vacuum. Formally, Debye screening appears from a pole at purely imaginary k in the photon propagator in plasma, $(k^2 + \Pi_{00})^{-1}$, where Π_{00} is the time-time component of the photon polarization operator.

More generally, the photon equation of motion in momentum space can be written as - see section 3.1:

$$[k^\rho k_\rho g^{\mu\nu} - k^\mu k^\nu + \Pi^{\mu\nu}(k)] A_\nu(k) = \mathcal{J}^\mu(k), \quad (1.45)$$

where $\Pi^{\mu\nu}(k)$ is the photon polarization tensor. In vacuum, $\Pi^{\mu\nu}$ is made of null components, while in medium it is non vanishing and gives rise to the modifications with respect to the standard electro-magnetic interactions.

In the electrostatic case, when $\omega = 0$, it follows from equation (1.45) that:

$$(|\mathbf{k}|^2 - \Pi_{00}) A_0 = -q, \quad (1.46)$$

where q is the (small) charge of the test particle. When Π_{00} is independent on the photon momentum \mathbf{k} , equation (1.46) becomes the usual equation for a scalar field with mass $m = \sqrt{-\Pi_{00}}$. In this case, which is usually realized at least for small $|\mathbf{k}|$, the Debye mass m_D is equal to $\sqrt{-\Pi_{00}}$ and the electrostatic potential turns from the Coulomb to the Yukawa one. Clearly, in this case the Debye mass coincides with the inverse of the screening length.

In the presence of a BEC, the simple relation $m_D = \sqrt{-\Pi_{00}(\omega = 0)}$ becomes invalid and a more general definition is needed. Hence, the Debye mass is defined as the position of the poles of the inverse operator $(|\mathbf{k}|^2 - \Pi_{00})^{-1}$.

By an evident reason the screening effects were studied historically first in fermionic i.e. in electron-proton and in electron-positron plasma, taking into account finite temperature T and non vanishing chemical potential μ effects [39]. Some examples that can be found in the literature are plasma consisting of:

- Relativistic fermions with $m_F \ll T, \mu_F$: $m_D^2 = e^2 (T^2/3 + \mu_F^2/\pi^2)$.
- Non relativistic fermions: $m_D^2 = e^2 n_F/T$ where

$$n_F = \frac{\exp(\mu/T)}{\pi^2} \int dq q^2 e^{-q^2/2m_F T}.$$

- Massless scalars without chemical potential: $m_D^2 = e^2 T^2/3$.

For degenerate fermionic plasma another and quite striking behavior was found. Namely the screened potential drops down as a power of distance, $1/r^3$ in non-relativistic case and $1/r^4$ in relativistic case multiplied by an oscillating function, $\cos(k_F r)$ or $\sin(k_F r)$, where k_F is the Fermi momentum. This phenomenon is called Friedel oscillations [55; 56]. It is prescribed to a sharp (non-analytic) cut-off of the Fermi distribution of degenerate electronic plasma at $T = 0$ combined with the logarithmic singularity of the photon polarization operator $\Pi_{00}(\omega = 0, k)$.

Plasma with charged bosons attracted attention much later, both for pure scalar electrodynamics, for a review see e.g. reference [57], and for quark-gluon plasma [39; 58]. Surprisingly until very recently the impact of possible Bose condensate of charged fields on the photon polarization operator was not considered. Only recently an investigation of plasma with Bose condensate of charged scalars was initiated, see chapter 2 of this thesis and references [4; 9; 10; 11; 12; 13; 14; 15; 59; 60]. It was found that in the presence of Bose condensate the screened potential behaves similarly to that in the degenerate fermionic case, i.e. the potential oscillates, exponentially decreasing with distance [4; 9]. This effect, however, in contrast to Friedel oscillations, does not come from the logarithmic branch point singularity in Π_{00} but from the pole in the photon propagator at

complex (not purely imaginary) value of k . It was shown that the polarization operator contains infrared singular term $\Pi_{00} \sim 1/k^2$ [9; 12] which shifts the pole position from imaginary axis (as in Debye case) to a point with non-zero real and imaginary parts.

At non-zero temperature the polarization operator has another infrared singular term $\sim 1/k$. This term is odd with respect to the parity transformation, $k \rightarrow -k$ and, as a result, the potential acquires a term which decreases as a power of distance but does not oscillate [9; 10]. Finally, the polarization operator has logarithmic singularity as in the fermionic case and this singularity also generates an oscillating potential similar to the Friedel one. It is interesting that the screened potential is a non-analytic function of the electric charge e . In particular in certain limit it may be inversely proportional to e , despite being calculated in the lowest order in e^2 .

Another oscillatory and exponentially damped behavior of the potential between static charges has been reported in the literature: it was argued [61] that in nuclear matter at high densities and low temperatures, the Debye pole acquires a non-zero real part and so the screened potential oscillates (see also [62]). These *Yukawa oscillations* are short-ranged oscillations and fade away with distance faster, as compared to the Friedel oscillations.

Screening of color charges in QCD in the presence of uncharged pion condensate was considered recently in [63]. Since the condensate is uncharged, its effect is quite different from what is discussed above.

Another quantity of interest is the plasma frequency ω_p , which enters the dispersion relation of electromagnetic waves propagating in plasma. It is defined as the limit of $\mathbf{k} \rightarrow 0$ of certain space-space components Π_{ij} . Using the transversality condition, $k^\mu \Pi_{\mu\nu} = 0$, we can decompose the photon polarization operator in a medium in terms of two scalar functions, $a(\omega, |\mathbf{k}|)$ and $b(\omega, |\mathbf{k}|)$:

$$\Pi_{ij} = a \left(\delta_{ij} - \frac{k_i k_j}{\mathbf{k}^2} \right) + b \frac{k_i k_j}{\mathbf{k}^2}, \quad \Pi_{0j} = \frac{k_j}{\omega} b, \quad \Pi_{00} = \frac{\mathbf{k}^2}{\omega^2} b. \quad (1.47)$$

We have assumed here that the medium is isotropic and so a and b depend only on the absolute value of the photon momentum. In the limit $\Pi_{ij} \sim \delta_{ij}$, $a = b$, that is, plasma frequency is determined by the equation:

$$\omega_p^2 = b(\omega, |\mathbf{k} = 0|) = a(\omega, |\mathbf{k} = 0|). \quad (1.48)$$

Chapter 2

Ferromagnetic properties of vector boson condensate

This chapter of the thesis is mostly based on reference [6]. The Bose-Einstein condensation of the charged weak bosons, W^\pm is analyzed in the electroweak sector $SU(2) \times U(1)$. Such condensation might occur in the early universe if the cosmological lepton asymmetry was sufficiently large, as it is discussed in section 1.4. The primeval plasma is supposed to be electrically neutral and to have zero density of weak hypercharge.

In general a Bose-Einstein condensate of vector fields may form either a scalar state, when the average value of vector W_j is microscopically small, or a classical vector state when all the individual spins of the condensed vector bosons are aligned at a macroscopically large scale.

It is shown that, as long as we neglect screening effects, a ferromagnetic state, where all the spins are aligned, is realized. This is due to the competition of the dominant direct spin-spin interactions with the subdominant local quartic interaction of W s. Screening effects are finally discussed and it is shown how they may affect the previous results. Screening is not relevant in the broken phase, nevertheless it may turn the system into an antiferromagnetic one when the symmetry is restored.

2.1 Equations of motion of gauge bosons and their condensation.

In this chapter we consider the evolution of the gauge bosons of $SU(2) \times U(1)$ electroweak model. As it is discussed in section 2.3, since W bosons are free particles, their magnetic properties are essentially determined by the direct spin-spin interactions. The latter can be analyzed by considering the equations of motion of the boson fields in the E-W sector of the SM. The Lagrangian of the minimal electroweak model has the well known form

[21]:

$$L = L_{gb} + L_{sp} + L_{sc} + L_{Yuk}, \quad (2.1)$$

which are respectively the gauge boson, the spinor, the scalar, and the Yukawa contributions. Explicitly we have:

$$L_{gb} = -\frac{1}{4}G_{\mu\nu}^i G^{i\mu\nu} - \frac{1}{4}f_{\mu\nu} f^{\mu\nu}, \quad (2.2)$$

$$G_{\mu\nu}^i = \partial_\mu A_\nu^i - \partial_\nu A_\mu^i + g\epsilon^{ijk} A_\mu^j A_\nu^k, \quad f_{\mu\nu} = \partial_\mu B_\nu - \partial_\nu B_\mu,$$

$$L_{sp} = \bar{\Psi} i \not{D} \Psi, \quad D_\mu \Psi = \left(\partial_\mu - \frac{i}{2}g \sigma^j A_\mu^j - \frac{i}{2}g' Y B_\mu \right) \Psi,$$

$$L_{sc} = \frac{1}{2} (D_\mu \Phi)^\dagger (D_\mu \Phi) + \frac{1}{2}\mu^2 \Phi^\dagger \Phi - \frac{1}{4}\lambda (\Phi^\dagger \Phi)^2,$$

$$D_\mu \Phi = \left(\partial_\mu - \frac{i}{2}g \sigma^j A_\mu^j - \frac{i}{2}g' B_\mu \right) \Phi,$$

where $i = 1, 2, 3$ and the Yukawa Lagrangian describes interactions of fermions with the Higgs field.

In the expressions above A_μ^i and B_μ are the gauge boson potentials of the $SU(2)$ and $U(1)$ groups respectively, g and g' are their gauge coupling constants, Y is the hypercharge operator corresponding to the $U(1)$ group and σ^j are the Pauli matrices operating in $SU(2)$ space. As usually, the repeated indices imply summation.

In the broken phase the physical massive gauge boson fields are obtained through the Weinberg rotation:

$$W_\mu^\pm = \frac{A_\mu^1 \mp i A_\mu^2}{\sqrt{2}}, \quad Z_\mu = c_W A_\mu^3 - s_W B_\mu, \quad A_\mu = s_W A_\mu^3 + c_W B_\mu, \quad (2.3)$$

where c_W and s_W stand respectively for $\cos\theta_W$ and $\sin\theta_W$ and θ_W is the Weinberg angle. The other fields involved in the Lagrangians presented above are the spinor Ψ and the Higgs field $\Phi = [\phi^+, \phi^0]^T$. The latter, after symmetry breaking, acquires non-zero vacuum expectation value, v , and takes the form $\Phi = (1/\sqrt{2})[0, v + \phi_1^0]^T$, where the upper index T means transposition and ϕ_1^0 describes excitations in the broken symmetry phase, i.e. neutral massive Higgs particle. We are considering here one lepton family but the results can be easily generalized to the three family model. We use the unitary

gauge in which the particle content is explicit, for example physical gauge bosons have three polarization states and only one physical neutral Higgs field, ϕ_1 is present.

From the equations that we presented above, one can conclude that, in addition to the usual kinetic and mass terms, vector boson interactions contain cubic and quartic couplings, see e.g. reference [64]. The explicit lagrangian terms, respectively L_3 and L_4 , are presented in Appendix A, see equations (A.1) and (A.2). Given the lagrangians, one can easily calculate the equations of motion for the gauge bosons, which are explicitly written in Appendix A, see equations (A.4) and (A.5).

It should be noted that equations of motion (A.4,A.5), as they are written in the appendix, describe classical fields in the tree approximation and do not include the effects of W and Z instability. The latter can be taken into account by perturbative iteration of these equations. The effects of instability are discussed at the end of this section.

In what follows we assume that the total electric charge density of the plasma is zero and the average three-vector current vanishes as well. We will consider the case when the electric charge density of fermions, J_0^ψ , is non-vanishing and homogeneous. It is usually assumed that the primeval plasma is electrically neutral and thus the non-zero charge density of fermions must be compensated by the opposite sign charge density of W . To study such a system it is convenient to use the electromagnetic gauge freedom and to impose the condition $A_\mu = 0$. We also assume that the average value of $Z_\mu = 0$. In this case there exists a homogeneous solution of the equation of motion of the form:

$$W_\mu = C_\mu \exp(-im_W t), \quad (2.4)$$

where we impose the condition $\partial_\mu W^\mu = 0$ to eliminate the non-physical spin degrees of freedom. So C_μ is a constant vector with vanishing time component and m_W is the boson mass determined by the nonzero vacuum expectation value of the Higgs field ¹. In contrast, in some papers the gauge condition of time independent charged vector field is taken: $W_\mu = C_\mu$, while the electromagnetic vector potential is non-zero: $A_\mu = \delta_\mu^t m_W / e$. The latter gauge is used only in section 3.3.1 of this thesis in order to make a comparison between the two. As it should be, the physical results are not affected by the gauge choice.

In addition to the Higgs induced part, the mass of W_μ contains also the contributions induced by the temperature effects [39] and by the impact of the W -condensate itself, which are disregarded at this stage. The latter are the only ones which are present above the E-W phase transition. The consequent possible condensation of W at lower

¹We want to stress an important difference between Bose-Einstein condensate and Higgs condensate, which is often overlooked. The equation of state of the former is simply $P = 0$, while for the latter $P = -\rho$, where P and ρ are respectively pressure and energy densities.

lepton asymmetry in section 1.4.

Solution (2.4) corresponds to the Bose condensate of W -bosons describing a collection of these particles at rest. This field configuration corresponds to the condensation of the positively charged W^+ . The condensation of W^- is described by the complex conjugate expression. However, such a solution is not obligatory and depends upon the kinetics of the system and the interactions between W -bosons at rest. In fact the only condition which we have at this level is the condition of the electric neutrality and it demands only that the average values of bilinear combinations of W must be non-zero, while classical vector field W_μ may vanish on the average. A possible vanishing of the classical vector field W_j , where $j = 1, 2, 3$ is the spatial vector index, is physically quite evident. The condensate is a collection of W -bosons at rest with the charge density which compensates the charge density of fermions. The most probable state of such particles (the highest entropy state), if the spin-spin interaction is neglected, is the state with chaotic distribution of the individual spins. It is natural to expect that the average value of the total spin in such a state is zero or at least not macroscopically large. The situation is opposite in the ferromagnetic case when the spin alignment is energetically favorable and the classical vector field could be formed.

In the first paper of reference [5] a similar statement concerning the formation of a classical vector field was done but without an analysis of the dynamics introduced by the spin-spin interaction. In the quoted paper the mentioned above gauge, where W is time independent:

$$W_\mu = C_\mu, \quad A_\mu^{(0)} = (m_B/e) \delta_\mu^0 \quad (2.5)$$

is used, but the physical results are of course gauge invariant. In this gauge the condition of the charge neutrality becomes $2A_0 W_\mu^+ W_\mu^- = -J_0^\psi$, which is again bilinear in W field and from the condition of non-zero charge density of the condensed W 's does not follow that there exists the classical field $W_j \neq 0$.

W instability The instability of W can be introduced in the usual way by adding an imaginary part to the mass equal to the decay half-width. The introduction of such a term into the equation of motion for W leads to the exponential decay of the field, $W \sim \exp(-\Gamma t/2)$. However this description is valid only for the decay into vacuum.

For the decay into a dense medium the Fermi exclusion principle should be taken into account. Hence, if neutrinos have sufficiently large chemical potential, such that all the states where W could decay would be occupied, the decay rate would be exponentially suppressed and solution (2.4) could be physically realized. This observation establishes the equivalence between the kinetic approach of section 1.2.1 and that presented here.

In fact the absolute stability of the condensed W 's is unnecessary. Even if W -

bosons decay, the ferromagnetic condensate can be formed, if the time of the condensate formation is shorter than the life-time of W -bosons in the plasma. The condensed W -bosons are in the state of dynamical equilibrium: W 's evaporating from the condensate because of their decay or scattering of hot fermions, are compensated by W 's coming back by the inverse processes. In thermodynamical equilibrium the average number of W -bosons in the zero momentum state remains constant. The decay rate of the W -bosons in plasma is proportional to

$$\frac{\Gamma}{\Gamma_0} \sim \left[\left(e^{-(m_W/2+\mu_e)/T} + 1 \right) \left(e^{-(m_W/2-\mu_\nu)/T} + 1 \right) \right]^{-1}, \quad (2.6)$$

where $\Gamma_0 \sim \alpha m_W$ is the decay rate of W in vacuum. The right hand side of equation (2.6) comes from the Fermi suppression terms $(1 - f_{e^+})(1 - f_\nu)$. We consider the decay $W^+ \rightarrow \nu e^+$ and take into account that in thermal equilibrium the chemical potentials of electrons and positrons are equal by magnitude but have the opposite signs. In the case of very large lepton asymmetry, $n_L, \mu_\nu \gg T$, the decay rate of W -bosons would be exponentially suppressed and their life time can be longer than the time of the spin alignment, τ_S . As we mentioned above, the cosmological generation of $L \gg T^3$ may be realized in a version of the Affleck-Dine scenario [53] which leads to a cold universe with non-relativistic W -bosons. Moreover, even in absence of the exponential suppression and relatively small lepton asymmetry, $L \sim T^3$, the life-time of W -bosons in the plasma can be larger than τ_S . As is shown below, the Hamiltonian of spin-spin interaction is given by equations (2.13,2.18). Correspondingly the characteristic time of the spin alignment can be estimated as:

$$\tau_S \sim \frac{1}{U^{spin}} \sim \frac{m_W^2}{(n_W e^2 S^2)}, \quad (2.7)$$

where S is the total spin of the condensed W -bosons, $n_W \equiv 1/d^3$ is their number density, and d is the average distance between them. We approximated $\delta(\mathbf{r})$ as $1/d^3 = n_W$. Evidently τ_S can be considerably shorter than the life-time of W -bosons. The same ‘‘stability’’ arguments are applicable to the decay of W into quarks.

2.2 Spin-spin interactions of W bosons

As we mentioned above, the form of the vector boson condensate depends upon the interaction between the vector bosons at rest. If the latter favors the opposite spin configuration, i.e. a pair of bosons ‘‘prefers’’ to be in the zero spin state, the condensate would have zero total spin, i.e. W -bosons would form the scalar condensate (antiferromagnetic case). In the opposite situation of the favorable spin-two state, the spins of

all vector bosons in the condensate would be aligned and the condensate would have macroscopically large spin (ferromagnetic case).

In this section we discuss the interactions between the W boson spins, as they arise from the EW lagrangian. We show that there are three different contributions to the spin-spin coupling. The first is the spin-spin interaction induced by the electromagnetic interactions of W -bosons, namely by the coupling of their magnetic moments. This term favors a ferromagnetic configuration, where all the spins are aligned. The second contribution arises from the local quartic self-coupling of W and goes in the opposite direction, namely, it favors an anti-ferromagnetic configuration. Nevertheless, it is weaker than the direct magnetic interaction. Finally, there is a contribution from the Z -boson exchange between W 's, which is negligible in the broken phase and analogous to the electromagnetic one in the unbroken phase. As a result, on the whole, the W boson condensate shows ferromagnetic properties.

2.2.1 Electromagnetic interactions

The essential particles in the system we study in this section are the charged W bosons at rest and charged relativistic fermions, which ensure the electric neutrality of the medium. The latter are electrons (or positrons) and quarks but these details are not important. For relativistic fermions helicity is conserved and hence the interaction of their spins with the spins of W is not essential, because on the average the electron-positron medium is not spin-polarized. Accordingly we take into account only the spin-spin interaction of non-relativistic W -bosons and disregard the impact of the charged fermions.

The electromagnetic interaction between W -bosons is similar to the well known interaction of nonrelativistic electrons, which is described by the Breit equation see equation (2.30). The analogue of the Breit equation for W -bosons can be derived along exactly the same lines as is done for electrons. The electromagnetic interaction between two W bosons in the lowest order in the electric charge, e , is described by the usual one-photon exchange diagram. In the Feynman gauge, where the photon propagator is $D^{\mu\nu} = g^{\mu\nu}/q^2$, the amplitude corresponding to this diagram is:

$$M = -\frac{1}{(p_1 - p_2)^2} W^{\alpha'\dagger} W^{\beta'\dagger} V_{\alpha'\alpha\mu}(p_1, p_2, q) V_{\beta'\beta}{}^\mu(p_3, p_4, -q) W^\alpha W^\beta \quad (2.8)$$

where $V_{\alpha\beta\mu}$ is the most general CP invariant $W^\dagger W \gamma$ vertex [65]:

$$V_{\alpha\beta\mu}(p_1, p_2, q) = ie \left[p_\mu g_{\alpha\beta} + 2(q_\beta g_{\alpha\mu} - q_\alpha g_{\beta\mu}) + (1 - k_\gamma)(q_\beta g_{\alpha\mu} - q_\alpha g_{\beta\mu}) + \left(\frac{\lambda_\gamma}{2m_W^2}\right) p_\mu q_\alpha q_\beta \right], \quad (2.9)$$

where p_1 and p_3 are the momenta of the incoming particles, p_2 and p_4 are the momenta of the outgoing particles and $p = p_1 + p_2$, $q = p_2 - p_1$. This expression should be symmetrized with respect to the interchange of W -bosons in the initial and/or in the final states.

The vertex written above contains two anomalous coupling parameters k_γ and λ_γ . As we can see from equation (A.3), the standard electroweak model predicts, up to the second order in the electromagnetic coupling constant e : $k_\gamma = 1$, $\lambda_\gamma = 0$. In what follows we mostly assume that these values are true, since they are compatible with the present experimental data for triple gauge boson couplings [66]. In this case the amplitude (2.8) reduces to:

$$M = \frac{e^2}{q^2} W_1^{\alpha'\dagger} W_2^{\beta'\dagger} [p_\mu g_{\alpha\alpha'} + 2(q_\alpha g_{\alpha'\mu} - q_{\alpha'} g_{\alpha\mu})] \cdot [p^\mu g_{\beta\beta'} - 2(q_\beta g_{\beta'\mu} - q_{\beta'} g_{\beta\mu})] W_1^\alpha W_2^\beta. \quad (2.10)$$

The spin-spin interaction is contained in the product of the last two terms in the square brackets in equation (2.10) i.e. the terms containing vector q . The spin operator of vector particles is defined as the generator of the rotation group belonging to its adjoint representation and is equal to the vector product:

$$\mathbf{S}_1 = -i \mathbf{W}_1^\dagger \times \mathbf{W}_1. \quad (2.11)$$

Hence the scattering amplitude induced by the interaction between the magnetic moments of the charged vector bosons is equal to:

$$M_S = -\frac{e^2 \rho^2}{m_W^2 q^2} [q^2 (\mathbf{S}_1 \cdot \mathbf{S}_2) - (\mathbf{S}_1 \cdot \mathbf{q})(\mathbf{S}_2 \cdot \mathbf{q})], \quad (2.12)$$

where ρ is the ratio of the real magnetic moment of W to its value predicted by the standard electroweak theory (e^2/m_W^2) and we divided by $4m_W^2$ for proper normalization of the W -wave function, as is explained below, see section 2.2.2.

The potential which describes the electromagnetic spin-spin interaction is the Fourier transform of amplitude (2.12) and is equal to:

$$U_{em}^{spin}(r) = \frac{e^2 \rho^2}{4\pi m_W^2} \left[\frac{(\mathbf{S}_1 \cdot \mathbf{S}_2)}{r^3} - 3 \frac{(\mathbf{S}_1 \cdot \mathbf{r})(\mathbf{S}_2 \cdot \mathbf{r})}{r^5} - \frac{8\pi}{3} (\mathbf{S}_1 \cdot \mathbf{S}_2) \delta^{(3)}(\mathbf{r}) \right]. \quad (2.13)$$

This potential has the same form as the corresponding one in the Breit's equation for electrons (2.30) but with different numerical coefficients.

To calculate the contribution of this potential into the energy of two W -bosons at rest we have to average it over their wave function. In particular, in the condensate case,

it is a S-wave function that is angle independent. Hence the contributions of the first two terms in equation (2.13) mutually cancel out and only the third one remains, which has negative coefficient. Thus the energy shift induced by the spin-spin interaction is equal to:

$$\delta E = \int \frac{d^3r}{V} U_{em}^{spin}(r) = -\frac{2e^2\rho^2}{3Vm_W^2} (\mathbf{S}_1 \cdot \mathbf{S}_2), \quad (2.14)$$

where V is the normalization volume.

Since $S_{tot}^2 = (S_1 + S_2)^2 = 4 + 2S_1S_2$, the average value of S_1S_2 is equal to:

$$S_1S_2 = S_{tot}^2/2 - 2. \quad (2.15)$$

For $S_{tot} = 2$ this term is $S_1S_2 = 1 > 0$, while for $S_{tot} = 0$ it is $S_1S_2 = -2 < 0$. Thus, if the spin-spin interaction is dominated by the interactions between the magnetic moments of W bosons, the state with their maximum total spin is more favorable energetically and W -bosons should condense in the ferromagnetic state. This could lead to the spontaneous magnetization in the early universe.

2.2.2 Quartic self-coupling of W

The contribution to the spin-spin interactions of W comes from the first term in Lagrangian (A.2) or from the third term in the r.h.s. of equation of motion (A.4). The first term in Lagrangian (A.2) can be rewritten as:

$$L_{4W} = -\frac{e^2}{2\sin^2\theta_W} [(W_\mu^\dagger W^\mu)^2 - W_\mu^\dagger W^{\mu\dagger} W_\nu W^\nu] = \frac{e^2}{2\sin^2\theta_W} (\mathbf{W}^\dagger \times \mathbf{W})^2. \quad (2.16)$$

It is assumed here that $\partial_\mu W^\mu = 0$ and thus only the spatial 3-vector \mathbf{W} is non-vanishing, while $W_t = 0$.

Since the corresponding Hamiltonian is obtained from L_{4W} by changing sign and since spin operator (2.11) contains imaginary unit factor, the sign of the Hamiltonian is positive. It means that the low spin states are energetically favorable.

For the comparison of this Hamiltonian with potential energy (2.13) we need to properly normalize the wave functions of W . In the Hamiltonian the usual relativistic normalization is used, according to which the number density of W is equal to $n_W = 2m_W \mathbf{W}^\dagger \mathbf{W}$, while in the non-relativistic Schroedinger equation the wave function is normalized to unity,

$$\int d^3r |\psi|^2 = 1. \quad (2.17)$$

Accordingly the Hamiltonian should be divided by $4m_W^2$. Its Fourier transform, producing the spin-spin interaction potential, would be:

$$U_{4W}^{(spin)} = \frac{e^2}{8m_W^2 \sin^2 \theta_W} (\mathbf{S}_1 \mathbf{S}_2) \delta^{(3)}(\mathbf{r}). \quad (2.18)$$

Thus the quartic self-coupling of W contributes to the spin-spin favoring the formation of an antiferromagnetic state.

The same result can be obtained from equation of motion (A.4) if one takes into account that in the non-relativistic limit:

$$\partial_t^2 \mathbf{W} = (-E^2 + m_W^2) \mathbf{W} \approx 2m_W \epsilon \mathbf{W}, \quad (2.19)$$

where $\epsilon = (E - m_W)$ is the non-relativistic energy.

2.2.3 Z -boson exchange

The contribution to the spin-spin potential between a pair of W from the Z -boson exchange can be found from equation (A.4) where we substitute the expression for Z_ν taken from equation (A.5) in the limit of vanishing four-momentum of Z . Indeed the transferred momentum is much smaller than m_Z , and so the diagram with Z -exchange is effectively local with Z -boson propagator equal to $1/m_Z^2$. Hence the contribution from the Z -exchange in the e^2 order to equation (A.4) is:

$$\partial_\mu W_i^\mu + m_W^2 W_i + 4e^2 \cot^2 \theta_W (m_W/m_Z)^2 (\mathbf{W}^\dagger \mathbf{W}) W_i + \dots = 0, \quad (2.20)$$

where $j = 1, 2, 3$ is the spatial vector index.

We see that the Z -boson exchange does not contribute to the spin-spin interactions of W . However, it should be kept in mind that this result is true only for the non-relativistic Z -bosons, while above the phase transition the contributions of Z bosons and photons are similar.

2.2.4 Plasma screening

We have already introduced plasma screening in section 1.5. In plasma the time-time component of the photon propagator is modified as $1/\mathbf{q}^2 \rightarrow 1/[\mathbf{q}^2 + \Pi_{00}(\mathbf{q})]$, where $\Pi_{00}(\mathbf{q})$ is the photon polarization operator in plasma and \mathbf{q} is the photon momentum. Usually $\Pi_{00} = m_D^2$, where m_D is the Debye screening mass, which is independent on \mathbf{q} . So the pole at $q^2 = 0$ shifts to an imaginary q leading to the well known effects of the Debye screening. As it was found recently [9; 10; 11; 12; 13; 14], the presence of the charged

Bose condensate drastically changes the polarization operator leading to an explicit dependence of Π_{00} on \mathbf{q} which gives rise to infrared singular terms. The modification of the propagator takes place already in the lowest order in the electromagnetic coupling, e^2 , i.e. in the one loop approximation. This issue is discussed in detail in chapter 3.

On the other hand, the space-space component of the propagator remains massless, $\Pi_{ij} \sim 1/\mathbf{q}^2$. It is known to be true in pure Abelian electrodynamics in any order of perturbation theory, while in non-Abelian theories the screening may occur in higher orders of perturbation theory due to the infrared singularities [67]. Screening may potentially change the relative strength of the electromagnetic spin-spin coupling, which is affected by screening effects, with respect to local W^4 coupling which is not screened. However, in the broken phase the system is reduced to the usual electrodynamics, where screening is absent and W -bosons would condense in the ferromagnetic state. In the unbroken phase of the electroweak theory the answer is not yet known. Perturbative calculations are impossible because of the violent infrared singularities. Maybe lattice calculations analogous to those done in QCD would help.

The potential describing the magnetic spin-spin interaction is related to amplitude (2.12) with a modified photon propagator. Thus it can be written as:

$$U_{em}^{(spin)}(\mathbf{r}) = -\frac{e^2 \rho^2}{m_W^2} \int \frac{d^3 q}{(2\pi)^3} \frac{\exp(i\mathbf{q}\mathbf{r})}{(q^2 + \Pi_{ss}(\mathbf{q}))} [q^2 (\mathbf{S}_1 \cdot \mathbf{S}_2) - (\mathbf{S}_1 \cdot \mathbf{q})(\mathbf{S}_2 \cdot \mathbf{q})] , \quad (2.21)$$

where Π_{ss} is the plasma correction to the space-space component of the photon propagator.

If, as above, we assume that the wave function of W -bosons is space independent and average this potential over space, we obtain the following expression for the spin-spin part of the energy shift:

$$\begin{aligned} \delta E &= \int \frac{d^3 r}{V} U_{em}^{(spin)}(\mathbf{r}) \\ &= -\frac{e^2 \rho^2}{V m_W^2} \int \frac{d^3 q}{(2\pi)^3} \delta^{(3)}(\mathbf{q}) \frac{q^2 (\mathbf{S}_1 \cdot \mathbf{S}_2) - (\mathbf{q} \cdot \mathbf{S}_1)(\mathbf{q} \cdot \mathbf{S}_2)}{q^2 + \Pi_{ss}(\mathbf{q})} \end{aligned} \quad (2.22)$$

Clearly δE vanishes if Π_{ss} is non-zero at $q = 0$. Of course, this is an unphysical conclusion, because the integration over r should be done with some finite upper limit, $r_{max} = l$, presumably equal to the average distance between the W bosons. So instead of the delta-function, $\delta^{(3)}(\mathbf{q})$, we obtain:

$$\int_0^l d^3 r \exp(i\mathbf{q}\mathbf{r}) = \frac{4\pi}{q^3} [\sin(ql) - ql \cos(ql)] . \quad (2.23)$$

The energy shift is given by the expression:

$$\delta E = -4\pi \frac{e^2 \rho^2}{V m_W^2} S_1^i S_2^j \int \frac{d^3 q}{(2\pi)^3} \frac{[\sin(ql) - ql \cos(ql)] [q^2 \delta_{ij} - q^i q^j]}{q^3 [q^2 + \Pi_{ss}(q)]}, \quad (2.24)$$

where $V = 4\pi l^3/3$.

When we average over an angle independent wave function, e.g. S-wave for the condensate, the non-vanishing part of the integral in equation (2.24) is proportional to the Kronecker delta, hence:

$$\delta E = S_1^i S_2^j A \delta^{ij}, \quad (2.25)$$

where the coefficient A can be calculated by taking trace of equation (2.24):

$$Tr(A\delta^{ij}) = 3A = -8\pi \frac{e^2 \rho^2}{m_W^2} \int \frac{d^3 q}{(2\pi)^3} \frac{[q \sin(ql) - q^2 l \cos(ql)]}{q^2 [q^2 + \Pi_{ss}(q)]}. \quad (2.26)$$

Hence the energy shift of a pair of W -bosons in S-wave state due to the spin-spin interaction is:

$$\delta E = -(\mathbf{S}_1 \cdot \mathbf{S}_2) \frac{8\pi e^2 \rho^2}{3V m_W^2} \int \frac{d^3 q}{(2\pi)^3} \frac{[\sin(ql) - ql \cos(ql)]}{q [q^2 + \Pi_{ss}(q)]}, \quad (2.27)$$

Introducing the new integration variable $x = ql$ we can rewrite it as:

$$\delta E = -(\mathbf{S}_1 \cdot \mathbf{S}_2) \frac{4e^2 \rho^2}{3\pi V m_W^2} \int_0^\infty \frac{dx}{x^2 + l^2 \Pi_{ss}(x/l)} [x \sin x + l^2 \Pi_{ss}(x/l) \cos x], \quad (2.28)$$

We used here the usual regularization of divergent integrals: $\exp(\pm iql) \rightarrow \exp(\pm iql - \epsilon q)$ with $\epsilon \rightarrow 0$. With such regularization $\int_0^\infty dx \cos(x) = 0$.

Evidently, if $\Pi_{ss} = 0$, we obtain the same result as that found in section 2.2.1. In fact the necessary condition for obtaining the “unscreened” result is $l^2 \Pi_{ss}(x/l) \ll 1$, but for a large $l^2 \Pi_{ss}$ the electromagnetic part of the spin-spin interaction can be suppressed enough to change the ferromagnetic behaviour into the antiferromagnetic one. This might take place at high temperatures above the EW phase transition when the Higgs condensate is destroyed and the masses of W and Z appear only as a result of temperature and density corrections and thus are relatively small. The quantitative statement depends upon the modification of the space-space part of the photon propagator in presence of the Bose condensate of charged W . As far as we know, this modification has not yet been found.

2.3 Magnetic properties of BECs

Magnetic properties of matter are determined by the state of outer (unpaired) electrons. For instance, let us consider an atomic system. Pairs of electrons belonging to different atoms may be either in symmetric, $S_{tot} = 1$, or antisymmetric, $S_{tot} = 0$, spin state. Since the total wave function of two electrons must be antisymmetric, their spin state has opposite symmetry with respect to their orbital wave function. Symmetric and antisymmetric electron states evidently have different energies, which we denote as E_s and E_a respectively. Accordingly, the spin Hamiltonian can be written as [68]:

$$H^{spin} = -J \mathbf{S}_1 \cdot \mathbf{S}_2. \quad (2.29)$$

The quantity $J = (E_s - E_a)$ is usually called the exchange energy. Its sign is determined by the atomic ground state structure. Evidently $J > 0$ favors parallel spins, while $J < 0$ favors antiparallel spins.

Besides exchange energy, electrons have direct magnetic dipole (spin-spin) interactions, which are described by the Breit equation [69]:

$$U^M(r) = \frac{e^2}{16\pi m_e^2} \left[\frac{(\sigma_1 \cdot \sigma_2)}{r^3} - \frac{3(\sigma_1 \cdot \mathbf{r})(\sigma_2 \cdot \mathbf{r})}{r^5} - \frac{8\pi}{3} (\sigma_1 \cdot \sigma_2) \delta^{(3)}(\mathbf{r}) \right], \quad (2.30)$$

where $\sigma_{1,2}$ are the spin operators of the electrons, i.e. the Pauli matrices averaged respectively over the first and second electron wave functions, and $e^2 = 4\pi\alpha = 4\pi/137$ ¹.

In atomic systems the exchange energy at small distances is typically of the order of fractions of eV, that is about 10^3 times larger than the typical spin-spin interaction between electrons. Hence the exchange interaction may force the magnetic dipoles of electrons to be aligned or anti-aligned independently on their direct magnetic interaction. The situation changes at large distances, since the exchange energy decays exponentially, while the magnetic interaction behaves like r^{-3} . Thus the latter dominates on macroscopic scales, leading to the breaking of the system into domains with different directions of the magnetic field and consequently to zero net macroscopic magnetization. Nevertheless, the ferromagnetic nature emerges when an external magnetic field is applied to the system.

Let us consider now W bosons in the early universe. Fortunately this system is simpler than solid state physics ones. In the primordial plasma all the condensed W -bosons, which are in symmetric orbital state, would be in the same state with zero momentum and not binded into a complicated atomic system. Evidently the exchange forces are not essential in this case. Hence their spin wave function should also be

¹To avoid confusion let us note that sometimes in the bibliography - see e.g reference [69] - the notation is different, namely $e^2 = \alpha$

symmetric and both the allowed spin states of W , the scalar, $S = 0$, and the tensor, $S = 2$, ones are also symmetric.

The realization of one or the other state is thus determined by the direct spin-spin interaction between the bosons. In the lowest angular momentum state, $l = 0$, a pair of bosons may have either spin 0 or 2. Depending on the sign of the spin-spin coupling, one of those states would be energetically more favorable and would be realized at the condensation. In the case of the energetically favorable higher spin state, $S = 2$, the vector bosons condense with macroscopically large value of their vector wave function $\langle W_j \rangle$. In the opposite case of the favorable $S = 0$ state the vector bosons form the scalar condensate with pairs of vector bosons making a scalar “particle”.

In principle, electrons and positrons could distort the spin-spin interactions of W by their spin or orbital motion and thus destroy the attraction of parallel spins of W . However, it looks hardly possible because electrons are predominantly ultra-relativistic and they cannot be attached to any single W boson to counterweight its spin. The low energy electrons cannot be long in such a state because of fast energy exchange with the energetic electrons. The scattering of electrons (and quarks) on W -bosons may lead to the spin flip of the latter, but in thermal equilibrium this process does not change the average value of the spin of the condensate.

The formation of ferro- or antiferromagnetic states in spin 1 condensates is observed in solid state physics with such spin-1 bosons as ^{23}Na , ^{39}K , and ^{87}Rb nuclei, see refs. [3], [70]-[72]. Usually experimental studies of the properties of the spin-1 condensate are performed in external magnetic fields. Under such conditions the spins of the vector bosons are aligned (frozen) due to the interactions of their magnetic moments with the external field. However, in optical traps an external magnetic field is absent and spin alignment or de-alignment depends upon the internal dynamics of the system. Correspondingly either ferromagnetic or scalar ground state would be formed depending on the scattering length of vector bosons in different angular momentum channels [70].

Due to macroscopically large value of the total spin in the ferromagnetic spin state the system can be accurately described by the mean field approximation, as is argued e.g. in section 12.2 of book [3] or refs. [71; 72]. Indeed, the validity of the mean field approximation is determined by the relative magnitude of the fluctuations near the ground state. The fluctuations are induced by the particle scattering which can change the spin value in a single reaction by ± 1 . It is clear that for a large value of the total spin the relative fluctuations $\delta S/S \sim \delta N/N \sim 1/\sqrt{N} \ll 1$, while for a small total spin value $\delta S/S \sim 1$.

In presence of sufficiently strong external magnetic field all the vector boson spins condense in the same direction and thus the whole body forms a single magnetic domain independently on the spin-spin interactions of the vector bosons, ferromagnetic or not.

On the contrary, when an external magnetic field is absent, several magnetic domains would be formed in the ferromagnetic case, due to dynamical instability, and none in the antiferromagnetic case. The discussion of this phenomenon in solid state physics and the list of references can be found e.g. in reference [73].

A different mechanism of formation of W -boson spin condensate by chaotic magnetic fields, which might exist in the early universe, was considered in reference [74]. If such fields were sufficiently strong, this mechanism could operate independently on the spin-spin interaction of W -bosons and would align their spins in the domains with the size of the order of that of the original cosmic magnetic field, which are normally microscopically small. To this end a magnetic field with the strength $B > \alpha m_W^2$ would be necessary. Such fields might be generated at the electro-weak phase transition. The alignment of the W spins reminds the alignment of vector fields in magnetic traps mentioned above. Moreover, such an alignment under the influence of a sufficiently strong external magnetic field would take place in both ferromagnetic and antiferromagnetic cases. However when the external magnetic field is switched-off or redshifted, the spins of the “antiferromagnetic” W -bosons would be dis-aligned making scalar condensate, while in the ferromagnetic case macroscopically large domains with aligned spins would be created. The mechanism of formation of such domains is different from the normal ferromagnets due to an absence of the exchange forces. So probably the size of the domains is not determined by the usual competition between the volume and surface energies but by the causality effects.

As we have shown, charged vector bosons would condense in maximum spin states and form classical vector field, if only electromagnetic interactions analogous to (2.30) between their spins are taken into account. In such a case the spontaneous magnetization at macroscopically large scales would take place. On the other hand, the local self-interaction of W creates the spin-spin coupling of the opposite sign. In the standard theory the magnitude of this coupling is smaller than that induced by the photon exchange, while the exchange of heavy Z -boson does not contribute at all into the spin-spin interactions of W -bosons. Thus the spin-spin coupling is dominated by the interactions of the magnetic moments of W . It should be noted that the expression for potential (2.30) created by the one photon exchange is true for virtual photons propagating in vacuum. The presence of plasma changes the propagator and could modify the spin-spin potential - see section 1.5. This is also true for non abelian theories, while the quartic local interaction is not screened. Hence one should check whether screening changes or not the system into an antiferromagnetic one. In pure electrodynamics magnetic fields are not screened and so one may expect that the plasma effects would not eliminate the dominance of the interactions between the magnetic moments. However, the situation is not clear in non-Abelian theories [75] and in principle the screening might inhibit the

spin-spin magnetic interaction, see section 2.2.4. If this is realized, the local quartic selfcoupling of W would dominate over the electromagnetic one and W bosons should condense in antiferromagnetic state and form a scalar condensate. Hence a classical vector field would not be created.

Our results are similar to that of reference [5] as long as the ferromagnetic case is realized. In this case the spins of W add up coherently creating classically large average vector W_j boson field. In the hypothetical situation of a stronger quartic self-coupling of W we arrive to an opposite conclusion of vanishingly small classical W field but with macroscopically large number density of W -bosons at rest, which is given by the bilinear product $n_W = i(\partial_t W_j^\dagger W_j - W_j^\dagger \partial_t W_j)$ (as we see in what follows, this expression for the number density of W is true in the gauge where the electromagnetic potential is zero).

2.4 Discussion of the results

In the case of W bosons the choice between ferromagnetic or antiferromagnetic state is determined by the spin-spin interaction of the individual W -bosons, realized through the interactions of their magnetic moments and their quartic self-coupling.

The total spin-spin interaction potential for W is the sum of two terms (2.13) and (2.18). As we have discussed below equation (2.13), the first two terms in the interaction of the magnetic moments cancel each other after averaging over a S-wave function. Thus only the δ -function term survives. In the standard electroweak model $\rho = 1$ and thus the absolute value of the coefficient in front of $\mathbf{S}_1 \mathbf{S}_2 \delta^{(3)}(\mathbf{r})$ in equation (2.13) is $2e^2/(3m_W^2)$ which is larger than the corresponding term in equation (2.18). Hence the former dominates and the energetically favored configuration of a multi- W state should have a macroscopically large total spin. However, as we have pointed out in section 2.2.4, the plasma screening of the interaction between the magnetic moments may be dangerous for the W -ferromagnetism. In the broken phase the problem is reduced to that of pure QED, where it is known that magnetic forces are not screened. However, in non-Abelian gauge theories the absence of screening is known only in the lowest order in perturbation theory, while higher order calculations suffer from strong infrared divergences and are not reliable. For the resolution of this problem non-perturbative methods, as e.g. lattice calculations, are necessary. At the moment the problem remains unsolved.

It should be also noted that, even though equations (2.30) and (2.13) are calculated for electrons and W bosons, they are valid respectively for any spin-(1/2) and spin-1 species having the usual electromagnetic interactions. So they may be applied to other particles, including the ones present in the extensions of the standard model. If these particles are in a S-wave state, on the average the only delta term survives and hence

they may form ferromagnetic states. Indeed, as one can see from equation (2.15), the lowest energy state for a S-wave function is the one with the maximum S_{tot}^2 .

It is clear from equations (2.13) and (2.18) that the condensate of W -bosons would be antiferromagnetic if the bosons have a negative non-standard contribution into the magnetic moment, such that $\rho < 3/(16 \sin^2 \theta_W)$. The ferromagnetism of W can be destroyed also in a model with a smaller value of the Weinberg angle. All that demands a strong deviation from the standard model and most probably is excluded, but these effects may be important in applications to extensions of the standard model, e.g. SUSY.

If a ferromagnetic state is formed, we would expect that the primeval plasma, where such bosons condensed (maybe due to a large cosmological lepton asymmetry), can be spontaneously magnetized. The typical size of the magnetic domains is determined by the cosmological horizon at the moment of the condensate evaporation. The latter takes place when the neutrino chemical potential, which scales as temperature in the course of cosmological cooling down, becomes smaller than the W mass at this temperature. However, if during the electroweak phase transition a very strong chaotic magnetic field was generated, the alignment of the spins of W -bosons and the domain size would be determined by this magnetic field. In the course of the cosmological expansion such field would drop down as the cosmological scale factor squared and the spins of W -bosons would behave as considered above. That is, their dynamics would be determined by the spin-spin interactions and microscopically small magnetic domains would rearrange themselves into macroscopically large ones in the same way as it happens in the usual ferromagnets.

Large scale magnetic field created by the ferromagnetism of W -bosons might survive after the decay of the condensate due to the conservation of the magnetic flux in plasma with high electric conductivity. Such magnetic fields at macroscopically large scales may be the seeds of the observed larger scale galactic or intergalactic magnetic fields. This problem will be studied elsewhere, we only note here that the mechanism of generation of galactic or intergalactic magnetic fields is unknown and presents a long standing cosmological problem, for reviews see e.g. reference [76]. Seed magnetic fields generated during inflation could be quite easily uniform at galactic or intergalactic scales, but they are too weak, hence a huge galactic dynamo is necessary to amplify them up to the observed magnitude. However, it is impossible in this way to explain the existence of intergalactic fields. On the other hand, seed fields generated at later stages of cosmological evolution could be quite large (e.g. magnetic fields created at some cosmological phase transitions), but the characteristic scale of such fields is by far smaller than the galactic one. The mechanism suggested here may generate large magnetic fields and at scales which are of the order of cosmological horizon at the electroweak temperatures. In this sense the mechanism is unique. Still even after the cosmological stretching up of

the characteristic wave length of the field, it remains smaller than the galactic radius. Nonetheless, with the “Brownian motion” reconnection of the field lines, the characteristic scale can be enlarged up to the galactic scale, though by an expense of their magnitude. Nevertheless with rather mild galactic dynamo the observed magnetic field may be generated.

Chapter 3

Condensate in plasma: medium effects

This chapter of the thesis is based on [9; 10; 11]. Here we discuss in detail the problem of screening for electromagnetic interactions taking place in plasma with a BEC component. Scalar condensate is considered for simplicity.

There are two standard approaches to field theory at nonzero temperature and chemical potentials: either imaginary time method (Matsubara formalism) or real time method (Schwinger-Keldysh formalism). The former is applicable only to the case of systems in thermal equilibrium, while the latter is valid for any state of the medium. For a review of these methods, see e.g. reference [77] or books [39]. In this chapter we calculate the photon Green's function for arbitrary medium in a physically transparent and simple way taking the expectation values of relevant operators not only over vacuum but over any state of the system, either it is a collection of particles with arbitrary occupation numbers or a coherent field state (the latter is possible for bosons only). We calculate the photon polarization operator in the medium and derive from it the electrostatic (Debye) screening length, the plasma frequency and more generally the photon dispersion relation. In all previously studied cases our results coincide with the known ones.

There may be some ambiguities in definition of the screening potential at higher orders in electric charge, e^4 and higher, and in non-Abelian gauge theories where the result may violate gauge invariance, as discussed in reference [78]. However, as long as we consider only Abelian $U(1)$ theory, as we do in this chapter and in the lowest, e^2 order, these ambiguities do not arise. Moreover, as one can see below, we have calculated the asymptotics of the screening potential at large distance in a self-consistent way by the location of the singularities in the complex k -plane, which are situated at non-zero k .

It is found that the screened electrostatic potential in the presence of BEC has an

oscillating behavior superimposed on the standard exponential decrease (Debye screening). The Debye screening length becomes parametrically shorter than in plasma of charged fermions and depends non-analytically on the electromagnetic coupling e . The electrostatic potential has also an other oscillating term analogous to Friedel oscillations for fermions and a power-law term. A power-law decreasing term appears also in the critical regime $\mu_B = m_B$, immediately before the formation of the condensate.

3.1 Perturbative calculations of the photon polarization operator

The Lagrangian of interacting electromagnetic field and charged scalar and fermion fields with masses m_B and m_F respectively and with opposite electric charges $\pm e$ has the form:

$$\mathcal{L} = -\frac{1}{4}F_{\mu\nu}F^{\mu\nu} - m_B^2|\phi|^2 + |(\partial_\mu + ieA_\mu)\phi|^2 + \bar{\psi}(i\cancel{\partial} - e\cancel{A} - m_F)\psi. \quad (3.1)$$

The Lagrangian is symmetric under the gauge transformations:

$$\begin{aligned} \phi(x) &\rightarrow \exp[ie\alpha(x)] \phi(x), & \psi(x) &\rightarrow \exp[ie\beta(x)] \psi(x), \\ A_\mu(x) &\rightarrow A_\mu(x) - \partial_\mu(\alpha + \beta) \end{aligned} \quad (3.2)$$

This implies the existence of two conserved currents and charges, which we can choose as the scalar and the fermion number. The Lagrangian (3.1) leads to the following equations of motion for the involved fields:

$$(i\cancel{\partial} - m)\psi(x) = e\cancel{A}\psi(x) \quad (3.3)$$

$$(\partial_\mu\partial^\mu + m^2)\phi(x) = \mathcal{J}_\phi(x) \quad (3.4)$$

$$\partial_\nu F^{\mu\nu}(x) = \mathcal{J}^\mu(x) \quad (3.5)$$

where the currents \mathcal{J} are defined as

$$\mathcal{J}_\phi(x) = -ie \left[\partial_\mu A^\mu(x) + 2A_\mu(x)\partial^\mu \right] \phi(x) + e^2 A^\mu(x)A_\mu(x)\phi(x) \quad (3.6)$$

$$\begin{aligned}
 \mathcal{J}^\mu(x) &= -ie \left[(\phi^\dagger(x) \partial^\mu \phi(x)) - (\partial^\mu \phi^\dagger(x)) \phi(x) \right] \\
 &+ 2e^2 A^\mu(x) |\phi(x)|^2 - e \bar{\psi}(x) \gamma^\mu \psi(x).
 \end{aligned} \tag{3.7}$$

Here $F_{\mu\nu} = \partial_\mu A_\nu - \partial_\nu A_\mu$ and \mathcal{J}^μ (3.7) is the total electromagnetic current of bosons and fermions in the coordinate space.

The key quantity which determines the photon propagation in plasma is the photon polarization tensor $\Pi^{\mu\nu}$ which we will calculate perturbatively. When doing this kind of calculations for massless fields, infrared singularities may arise and to regularize them one should use the resummation techniques - see e.g. [39] and references therein. Nevertheless it is safe to use the standard perturbative solution when the scalar and fermion field masses are not negligible as in the case we are considering. Moreover, the infrared singularities in Abelian theories are much milder than those in non-Abelian ones where the correspondence between the order of the perturbative series and the power of the coupling constant e is lost, see e.g. discussion in reference [26; 67]. Here we consider only Abelian QED and since it is not infrared dangerous, we neglect the resummation.

To derive the Maxwell equations with the account of the impact of medium on the photon propagator we have to average operators ϕ and ψ over the medium. The products of creation-annihilation operators averaged over the medium have the standard form:

$$\begin{aligned}
 \langle a^\dagger(\mathbf{q}) a(\mathbf{q}') \rangle &= f_B(E_q) \delta^{(3)}(\mathbf{q} - \mathbf{q}'), \\
 \langle a(\mathbf{q}) a^\dagger(\mathbf{q}') \rangle &= [1 + f_B(E_p)] \delta^{(3)}(\mathbf{q} - \mathbf{q}'), \\
 \langle c^\dagger(\mathbf{q}) c(\mathbf{q}') \rangle &= f_F(E_p) \delta^{(3)}(\mathbf{q} - \mathbf{q}'), \\
 \langle c(\mathbf{q}) c^\dagger(\mathbf{q}') \rangle &= [1 - f_F(E_p)] \delta^{(3)}(\mathbf{q} - \mathbf{q}'),
 \end{aligned} \tag{3.8}$$

where $f_{F,B}(E_q)$ are the energy dependent fermion/boson distribution functions, which may be arbitrary since we assumed only that the medium is homogeneous and isotropic. We also assumed, as it is usually done, that non-diagonal matrix elements of creation-annihilation operators vanish on the average due to decoherence. For the vacuum case $f_{F,B}(E) = 0$ and we obtain the usual vacuum average values of aa^\dagger and $a^\dagger a$, which from now on will be neglected because we are interested only in the matter effects.

We formally solve operator equations (3.3) and (3.4) as:

$$\phi(x) = \phi_0(x) + \int d^4y G_B(x-y) \mathcal{J}_\phi(y)$$

$$\psi(x) = \psi_0(x) + \int d^4y G_F(x-y)e\mathcal{A}(y)\psi(y) \quad (3.9)$$

where the zeroth order fields satisfy the free equations of motion:

$$(\partial_\mu\partial^\mu + m_B^2)\phi_0(x) = 0, \quad (i\cancel{\partial} - m_F)\psi_0(x) = 0 \quad (3.10)$$

and are quantized in the usual way

$$\begin{aligned} \phi_0(x) &= \int \frac{d^3q}{\sqrt{(2\pi)^3 2E}} [a(\mathbf{q}) \exp^{-iqx} + b^\dagger(\mathbf{q}) \exp^{iqx}] \\ \psi_0(x) &= \int \frac{d^3q}{\sqrt{(2\pi)^3}} \sqrt{\frac{m_F}{E}} [c_r(\mathbf{q})u_r(\mathbf{q}) \exp^{-iqx} + d_r^\dagger(\mathbf{q})v_r(\mathbf{q}) \exp^{iqx}]. \end{aligned} \quad (3.11)$$

In equation (3.11) $a^{(\dagger)}$, $b^{(\dagger)}$, $c^{(\dagger)}$ and $d^{(\dagger)}$ are the annihilation (creation) operators for scalar and spinor particles and antiparticles. The Green functions in equations (3.9) are the usual Feynman Green functions having the integral representation:

$$G_{B,F}(x-y) = \int \frac{d^4k}{(2\pi)^4} \exp^{-ik(x-y)} G_{B,F}(k) \quad (3.12)$$

where

$$G_B(k) = \frac{1}{k^2 - m_B^2 + i\epsilon}, \quad \text{and} \quad G_F(k) = \frac{\cancel{k} + m_F}{k^2 - m_F^2 + i\epsilon}. \quad (3.13)$$

Now we can substitute equations (3.9) into equation (3.5) with the currents given by equations (3.6) and (3.7). For the calculations up to the second order in the coupling constant e , i.e. up to e^2 , it is sufficient to include into \mathcal{J}_ϕ in equation (3.6) only terms of the first order in e , that is

$$\mathcal{J}_\phi(x) = +ie \left[\partial_\mu A^\mu(x) + 2A_\mu(x)\partial^\mu \right] \phi_0(x). \quad (3.14)$$

As a result we obtain:

$$\begin{aligned} \partial_\nu F^{\mu\nu}(x) &= -ie \left[(\phi_0^\dagger(x)\partial^\mu\phi_0(x)) - (\partial^\mu\phi_0^\dagger(x))\phi_0(x) \right] - e\bar{\psi}_0(x)\gamma^\mu\psi_0(x) \\ &\quad - ie\phi_0^\dagger(x)\partial^\mu \left[\int d^4y G_B(x-y)\mathcal{J}_{\phi_0}(y) \right] - ie \left[\int d^4y G_B(x-y)\mathcal{J}_{\phi_0}(y) \right]^\dagger \partial^\mu\phi_0(x) \\ &\quad + ie\partial^\mu\phi_0^\dagger(x) \left[\int d^4y G_B(x-y)\mathcal{J}_{\phi_0}(y) \right] + ie\partial^\mu \left[\int d^4y G_B(x-y)\mathcal{J}_{\phi_0}(y) \right]^\dagger \phi_0(x) \\ &\quad - e\bar{\psi}_0(x)\gamma^\mu \int d^4y G_F(x-y)e\mathcal{A}(y)\psi(y) - e \left[\int d^4y \bar{\psi}_0(y)\mathcal{A}(y)G_F^*(x-y) \right] \gamma^\mu\psi_0(x) \end{aligned}$$

$$+ 2e^2 A^\mu(x) |\phi_0(x)|^2. \quad (3.15)$$

The first term on the right hand side in equation (3.15), linear in e , is non-zero if the medium is either electrically charged or possesses an electric current. It is convenient to perform the Fourier transform:

$$A^\mu(k) = \int \frac{d^4x}{(2\pi)^3} \exp^{-ikx} A^\mu(x). \quad (3.16)$$

Finally we find that the field $A^\mu(k)$ satisfies the equation

$$[k^\rho k_\rho g^{\mu\nu} - k^\mu k^\nu + \Pi^{\mu\nu}(k)] A_\nu(k) = \mathcal{J}^\mu(k), \quad (3.17)$$

which is equivalent to the photon equation of motion (3.5) but in momentum space.

Thus the photon polarization tensor which contains contributions from charged bosons and fermions, $\Pi_{\mu\nu}(k) = \Pi_{\mu\nu}^B(k) + \Pi_{\mu\nu}^F(k)$, and the electromagnetic current \mathcal{J}_μ involved in equation (3.17) are explicitly found in the lowest order:

$$\begin{aligned} \Pi_{\mu\nu}^B(k) = e^2 \int \frac{d^3q}{(2\pi)^3 E} (f_B + \bar{f}_B) \cdot \\ \left[\frac{1}{2} \frac{(2q-k)_\mu (2q-k)_\nu}{(q-k)^2 - m_B^2} + \frac{1}{2} \frac{(2q+k)_\mu (2q+k)_\nu}{(q+k)^2 - m_B^2} - g_{\mu\nu} \right], \end{aligned} \quad (3.18)$$

$$\begin{aligned} \Pi_{\mu\nu}^F(k) = 2e^2 \int \frac{d^3q}{(2\pi)^3 E} (f_F + \bar{f}_F) \cdot \left[\frac{q_\nu (k+q)_\mu - q^\rho k_\rho g_{\mu\nu} + q_\mu (k+q)_\nu}{(k+q)^2 - m_F^2} \right. \\ \left. + \frac{q_\nu (q-k)_\mu + q^\rho k_\rho g_{\mu\nu} + q_\mu (q-k)_\nu}{(k-q)^2 - m_F^2} \right], \end{aligned} \quad (3.19)$$

$$\mathcal{J}_\mu = -e \int \frac{d^4x}{(2\pi)^4} \exp^{-ikx} \int \frac{d^3q}{(2\pi)^3} \frac{q_\mu}{E} \left[f_B - \bar{f}_B - 2(f_F - \bar{f}_F) \right], \quad (3.20)$$

where the arguments of the distribution functions, E and μ , are omitted. In equations (3.18) - (3.20) $k^\mu \equiv (\omega, \mathbf{k})$ and $q^\mu \equiv (E, \mathbf{q})$ are respectively the photon and the scalar/spinor four momenta, f_q and \bar{f}_q are the particle (antiparticle) distribution functions and $g_{\mu\nu} = (+ - - -)$. We assume the following charge convention: the bosons have electric charge $+e$, while fermions have electric charge $-e$. Of course the charge of antiparticles has the opposite sign. It is worth to stress that the total $\Pi^{\mu\nu}$ as well as its bosonic and fermionic components separately satisfy the transversality condition $k^\mu \Pi_{\mu\nu} = 0$. The last term in equation (3.18) describes the contribution from the tadpole

diagram and coincides with that found in reference [79]. Evidently without this term the transversality condition would be violated.

3.2 Photon propagation in plasma

The screening of test charge in the static case is determined by the zero frequency value of $\Pi_{00}(0, k)$. We assume that plasma is homogeneous and isotropic, so the polarization tensor depends only upon the magnitude of vector \mathbf{k} but not on its direction. Since the distribution functions depend only upon the energy, the integral over angles in equations(3.18) and (3.19) can be taken. In particular for time-time component of the polarization tensor in the limit of $\omega = 0$ we find ¹:

$$\Pi_{00}^B = -\frac{e^2}{2\pi^2} \int_0^\infty \frac{dq q^2}{E} (f_B + \bar{f}_B) \left(1 + \frac{E^2}{kq} \ln \left| \frac{2q+k}{2q-k} \right| \right), \quad (3.21)$$

$$\Pi_{00}^F = -\frac{e^2}{\pi^2} \int_0^\infty \frac{dq q^2}{E} (f_F + \bar{f}_F) \left(1 + \frac{E^2}{kq} \ln \left| \frac{2q+k}{2q-k} \right| \right). \quad (3.22)$$

Here and in what follows k and q are respectively the absolute values of the spatial component of the photon and charged particle momenta and we omit the arguments in the polarization tensor, i.e. write $\Pi_{00}(0, k) \equiv \Pi_{00}$. The argument of the logarithm comes in absolute value because the Green's functions in the perturbative expansion appear in the combinations $G(q+k) + G^*(q-k)$. So the imaginary part of Π_{00} in the considered limit vanishes.

It is even simpler to calculate the space-space components, Π_{ij} in the limit of zero photon momentum, $k = 0$:

$$\Pi_{ij}^B = \frac{e^2}{2\pi^2} \delta_{ij} \int \frac{dq q^2}{E} \left(1 - \frac{4}{3} \frac{q^2}{4E^2 - \omega^2} \right) (f_B + \bar{f}_B), \quad (3.23)$$

$$\Pi_{ij}^F = \frac{4e^2}{\pi^2} \delta_{ij} \int \frac{dq q^2}{E} \frac{E^2 - q^2/3}{4E^2 - \omega^2} (f_F + \bar{f}_F). \quad (3.24)$$

It is clear from these expressions that, in the limit $k = 0$, the functions a and b defined in (1.47) are equal.

At $\omega = 2m$ the polarization operator acquires a non-zero imaginary part which corresponds to the threshold of two charged particles production by the photon. For massless charged particles the threshold is at $\omega = 0$ and one has to take into account that the effective photon mass in plasma is non-zero (it is essentially the plasma frequency). This

¹It should be noted that two different sign conventions are used in the literature for Π_{00} . We follow here the notation of [9]. Of course the physical results, such as the potential, do not depend on the sign choice.

can be done using resummation technique. Accordingly the position of the threshold moves a little, as $\sim \epsilon T$. This is not essential for our consideration. Moreover electrodynamics with massless charged particles has serious infrared problems.

Let us now apply these results for the calculation of the plasma frequency and the Debye mass in some special cases which have been considered in the literature.

Massless SpQED and SQED with vanishing chemical potentials and high temperature, $T \gg m_{B,F}$: In thermal equilibrium the distributions of bosons and fermions and their antiparticles with zero chemical potentials have the usual Bose-Einstein or Fermi-Dirac form:

$$\begin{aligned} f_B(E, T) &= \bar{f}_B(E, T) = \frac{1}{\exp(E/T) - 1}, \\ f_F(E, T) &= \bar{f}_F(E, T) = \frac{1}{\exp(E/T) + 1}, \end{aligned} \quad (3.25)$$

where in high temperature limit we can neglect the particle mass i.e. we can assume $E = |\mathbf{q}|$. In this special case Π_{00} does not depend on the photon momentum \mathbf{k} and so $m_D = \sqrt{-\Pi_{00}}$. The integrals in equations (3.18) and (3.19) can be easily taken and we find for the contributions from bosons and fermions respectively:

$$\begin{aligned} m_{DB}^2(m_B = 0) &= m_{DF}^2(m_F = 0) = \frac{1}{3} e^2 T^2, \\ \omega_{PB}^2(m_B = 0) &= \omega_{PF}^2(m_F = 0) = \frac{1}{9} e^2 T^2. \end{aligned} \quad (3.26)$$

Hence the total Debye mass and the plasma frequency for the Lagrangian (3.1) are

$$m_D^2(m_B = m_F = 0) = \frac{2}{3} e^2 T^2, \quad (3.27)$$

$$\omega_P^2(m_B = m_F = 0) = \frac{2}{9} e^2 T^2 \quad (3.28)$$

These expressions coincide with the published results in the lowest order in the electromagnetic coupling, e^2 , see e.g. [39; 57].

In the case of relativistic fermions with non-zero chemical potential μ we obtain:

$$m_D^2(m_F = 0) = e^2 \left(\frac{T^2}{3} + \frac{\mu^2}{\pi^2} \right). \quad (3.29)$$

This is the result found in reference [80].

Massive SpQED with non-zero chemical potential and low temperature, $T \rightarrow 0$. In thermal equilibrium the distributions of fermions and their antiparticles are in this case the Boltzmann distributions:

$$f_F(E, \mu, T) = e^{(\mu-E)/T}, \quad \bar{f}_F(E, \mu, T) = e^{-(\mu+E)/T} \quad (3.30)$$

and once again Π_{00} does not depend on k , so it coincides with the Debye mass squared. Hence in the case of relatively small chemical potentials, $\mu < m$, we obtain:

$$\Pi_{00} = \frac{4e^2}{T} \left(\frac{mT}{2\pi} \right)^{3/2} e^{-m/T} \cosh(\mu/T). \quad (3.31)$$

In the case of strongly degenerate, $\mu \geq m$, nonrelativistic fermionic plasma, the contribution of anti-fermions may be neglected, while the fermion distribution function has the form:

$$f_F = \exp\left(\frac{\mu}{T} - \frac{q^2}{2m_F T} \right) \quad (3.32)$$

The chemical potential can be expressed through the number density of the fermions:

$$n_F = \frac{\exp(\mu/T)}{\pi^2} \int dq q^2 e^{-q^2/2m_F T} \quad (3.33)$$

There is a factor 2 in the above expression which counts two spin degrees of freedom.

Correspondingly the Debye screening mass for nonrelativistic fermions is

$$m_D^2 = \frac{e^2 n_F}{T}, \quad (3.34)$$

which coincides with the classical result, see e.g. book [54].

Analogously we find from equation (3.24) the plasma frequency for nonrelativistic fermions:

$$\omega_p^2 = \frac{e^2 n_F}{m_F} \quad (3.35)$$

which is also the classical result.

We have done these simple exercises to check the validity of our results for $\Pi_{\mu\nu}$ comparing it to the known cases. Now we will turn to the calculations of the photon polarization tensor in the medium with Bose condensate of charged scalars.

3.3 Electrodynamics with BEC

Let us use now the first of equations (3.18) together with (3.21) and (3.22) to calculate $\Pi_{00}(\omega = 0, k \rightarrow 0)$ which is needed to work out the electrostatic potential of a test charge in the plasma with Bose condensate. The distribution functions for condensed particles and their antiparticles are:

$$\begin{aligned} f_B^{(C)}(E, C, T) &= \frac{1}{\exp[(E - m_B)/T] - 1} + C \delta(\mathbf{q}) \\ &\equiv f_B(E, m_B, T) + C \delta(\mathbf{q}), \end{aligned} \quad (3.36)$$

$$\bar{f}_B(E, -m_B, T) = \frac{1}{\exp[(E + m_B)/T] - 1}, \quad (3.37)$$

- see section 1.2. Hence:

$$\begin{aligned} \Pi_{00}(\omega = 0, |k| \rightarrow 0) &= \\ &- \frac{e^2}{2\pi^2} \int_0^\infty \frac{dq q^2}{E} [f_B(E_B, m_B, T) + \bar{f}_B(E_B, -m_B, T)] \left[1 + \frac{E_B^2}{kq} \ln \left| \frac{2q+k}{2q-k} \right| \right] \\ &- \frac{e^2}{2\pi^2} \int_0^\infty \frac{dq q^2}{E} [f_F(E_F, \mu_F, T) + \bar{f}_F(E_F, -\mu_F, T)] \left[2 + \frac{(4E_F^2 - k^2)}{2kq} \ln \left| \frac{2q+k}{2q-k} \right| \right] \\ &- \frac{e^2}{(2\pi)^3} \frac{C}{m_B} \left(1 + \frac{4m_B^2}{k^2} \right) \end{aligned} \quad (3.38)$$

Evidently the last (condensate) term in f_B gives rise to the quadratic infrared singularity $\Pi_{00} \sim 1/k^2$, as found in refs. [9; 12].

At non-zero temperature the pole singularity of the Bose distribution at $q = 0$ leads to an additional infrared pole $\sim 1/k$ in the polarization tensor of photons. This contribution arises from the bosonic (but not anti-bosonic) contribution to Π_{00} when $\mu = m_B$ even in the absence of the condensate and appears from the integration region where q is smaller or comparable to k . For small q the distribution function is infrared singular,

$$f_B(E_B, m_B, T) \approx 2m_B T / q^2. \quad (3.39)$$

Usually this singularity is not dangerous because it is canceled by the integration measure, $\sim q^2$. Instead in our case the logarithmic term behaves as k/q for $q > k$ and as q/k for $q < k$. So the integral is finite but has $1/k$ singularity. Indeed we can separate the integral into two parts $0 < q < k/2$ and $k/2 < q < \infty$. It is convenient to introduce for the first part the new integration variable $x = 2q/k$, so $0 < x < 1$. For the second

part we introduce $y = k/2q$, so y runs in the same limits, $0 < y < 1$. In the limit of small k we can expand $E \approx m + k^2 x^2 / 8m_B$. Correspondingly:

$$\exp \left[\frac{E - m_B}{T} \right] - 1 \approx k^2 x^2 / 8m_B T. \quad (3.40)$$

So the integral is reduced to

$$\int_0^1 \frac{dx}{x} \ln \left(\frac{1+x}{1-x} \right) = \frac{\pi^2}{4}. \quad (3.41)$$

The same contribution comes from the second part of the integral. So finally we obtain for the singular in k part of the photon polarization tensor in the case of $\mu = m_B$ and $C = 0$:

$$\Pi_{00} = \frac{e^2 m_B^2 T}{2k} \quad (3.42)$$

Numerical calculations without expansion of the energy and the exponent gives a very close result.

Thus at low values of the photon momentum Π_{00} can be expanded as:

$$\Pi_{00}^B(0, k) = -e^2 \left[h(T) + \frac{m_B^2 T}{2k} + \frac{1}{(2\pi)^3} \frac{C}{m_B} \left(1 + \frac{4m_B^2}{k^2} \right) \right], \quad (3.43)$$

where the function $h(T)$ is independent of k and has the limiting values:

$$h(T) = \begin{cases} T^2/3 & (\text{high } T) \\ \zeta(3/2)(m_B T^3)^{1/2}/(2\pi)^{3/2} & (\text{low } T) \end{cases}. \quad (3.44)$$

The low T limit of the function $h(T)$ is however always sub-dominant with respect to the second term in equation (3.43) which comes from the logarithmic term in equation (3.21).

In the expression of the photon polarization tensor written above the singularities of Π_{00} due to pinching of the integration contour by the poles of $f_B(E_B, m_B)$ and the logarithmic branch point in the integrand of equation (3.21) are not taken into account. It will be done below in section 3.5.

The contribution of fermions into the polarization tensor is not infrared singular, so it is convenient to present the latter as

$$\Pi_{00}^F(k) = \Pi_{00}^F(0) + [\Pi_{00}^F(k) - \Pi_{00}^F(0)], \quad (3.45)$$

where

$$\Pi_{00}^F(0) = -\frac{e^2}{\pi^2} \int \frac{dq}{E} (f + \bar{f})(q^2 + E^2). \quad (3.46)$$

The potential of a test charge, Q , modified by the plasma screening effects is given by the Fourier transform of the photon propagator in plasma:

$$\begin{aligned} U(r) &= \frac{Q}{(2\pi)^3} \int \frac{d^3k \exp(i\mathbf{k}\mathbf{r})}{k^2 - \Pi_{00}(k)} = \frac{Q}{2\pi^2} \int_0^\infty \frac{dk k^2}{k^2 - \Pi_{00}(k)} \frac{\sin(kr)}{kr} \\ &= \frac{Q}{2\pi^2 r} \mathcal{J}m \int_0^\infty \frac{dk k e^{ikr}}{k^2 - \Pi_{00}(k)}. \end{aligned} \quad (3.47)$$

Usually the integrand in equation (3.47) is an even function on k and the integration along the line of positive real k can be transformed into the contour integral in the upper complex k -plane. However, in the case of bosons with $\mu_B = m_B$ the polarization operator contains an odd term $m_B^2 T/2k$, equation (3.43), and the usual contour transformation is not applicable. So we express integral (3.47) through the integral along imaginary upper k -axis plus contribution of singularities in the upper k -plane. If Π_{00} is an even function of k and $(k^2 - \Pi_{00})^{-1}$ is regular on the imaginary k -axis, the imaginary part of the integral along the imaginary axis vanishes. If the integrand has a pole at positive imaginary $k = ik_D$, i.e.

$$k_D^2 + \Pi_{00}(ik_D) = 0, \quad (3.48)$$

this pole contributes into the integral as $i\pi\delta(k - ik_D)$ and gives rise to the usual exponential Debye screening. If Π_{00} contains an odd part, the integral along imaginary k axis gives a contribution to the potential which decreases only as power of distance [9].

For plasma with charged Bose condensate [4; 9] there are also poles at complex $k = k_p$, when both real and imaginary parts of k_p are non-zero. They produce oscillating behavior superimposed on the exponential decrease of the potential. It was argued [61] that complex poles also exist in plasma of strongly interacting particles (pions and nucleons) and in QCD plasma.

There are also logarithmic singularities of $\Pi_{00}(k)$ at some non-zero $\mathcal{J}m k$ and the integrals along the corresponding cuts also produce oscillations in the screened potential but the exponential cut-off is much weaker, it is proportional to temperature and for zero T it becomes a power law one. For fermions this effect, called Friedel oscillations, was discovered long time ago [55; 56]. The potential is calculated and discussed in detail in section 3.4. For bosons, a similar phenomenon was found in [10] and is discussed in section 3.5.

3.3.1 Calculations in another gauge

Though our result is gauge invariant and for the calculation of the Debye screening length we do not need to fix the gauge, still it may be instructive to make the calculations in the gauge used in reference [5]. The homogeneous state of charged scalars with non-zero charge density was described in this paper as

$$\phi = \phi_0 = \text{const}, \quad (3.49)$$

$$A_\mu^{(0)} = (m_B/e) \delta_\mu^0. \quad (3.50)$$

It can be easily seen that this solution is a gauge transform of the zeroth order state (in coupling e) used in the present paper:

$$\phi = \phi_0 \exp(im_B t), \quad (3.51)$$

$$A_\mu = 0. \quad (3.52)$$

Evidently such a state of ϕ describes a collection of bosons at rest i.e. of a Bose condensate. The electric charge density of the condensate can be read off equation (3.7) and is equal to:

$$J_0^{(C)} = 2em_B |\phi_0|^2. \quad (3.53)$$

Expressions (3.49,3.50) and (3.51,3.52) lead to the same result for the electric charge density. Comparing it with the charge density described by the equilibrium distribution (3.36) we find that we have to identify:

$$C/(2\pi)^3 = 2m_B |\phi_0|^2. \quad (3.54)$$

Perturbation theory is less convenient in gauge (3.49,3.50) because of large value of the background potential $A_0^{(0)} \sim 1/e$. We need to make the expansion:

$$A_\mu \rightarrow \frac{m_B}{e} \delta_\mu^0 + A_\mu, \quad (3.55)$$

$$\phi = \phi_0 + \phi_q, \quad (3.56)$$

where A_μ is the potential of the physical electromagnetic field in the plasma. It may describe e.g. Coulomb-like field around test charge when we discuss Debye screening or propagating waves in plasma when we talk about plasma frequency. This A_μ is equal to A_μ considered above when we worked in the gauge defined by equations (3.51,3.52). The quantum deviation from the condensed state of the scalar field, ϕ_q , is supposed to be zero on the average. Moreover, we assume for simplicity that the plasma temperature is

zero and thus $\langle \phi_q^2 \rangle$ vanishes as well (if the vacuum quantum fluctuations are subtracted). So ϕ enters only into description of virtual particles through the Green's function.

The equation of motion of ϕ_q has the form:

$$(\partial^2 - 2im_B\partial_0)\phi_q = 2em_B A_0\phi_0 + e^2(A_\mu)^2(\phi_0 + \phi_q) + ie [2A^\mu\partial_\mu + (\partial_\mu A^\mu)]\phi_q. \quad (3.57)$$

Only the first term in the r.h.s. of this equation will be essential in what follows.

It is straightforward to write down the equation for A_μ :

$$\partial^2 A_\mu - \partial_\mu(\partial^\nu A_\nu) = J_\mu^{(F)} - 2em_B\delta_\mu^0[\phi_0^2 - 2\phi_0 Re\phi_q] + \dots \quad (3.58)$$

Here we retained only terms which are essential for the calculation of the condensate impact on the photon propagation in plasma. The missing terms can be easily found from equation (3.15). The first term in equation (3.58) is the fermionic current. Together with the second term they make the total current in the plasma, which we assume as above to be zero, $J_\mu^{(F)} - 2em_B\delta_\mu^0\phi_0^2 = 0$. The remaining term in the r.h.s. can be found by perturbative solution of equation (3.57):

$$\phi_q = 2em_B \int G(x-y) [\phi_0 A_0(y) + \dots] \quad (3.59)$$

As above, we make the Fourier transformation (3.16) and obtain the correction to the time-time component of the polarization operator from the field ϕ_0 :

$$\delta\Pi_{00} = e^2 m_B^2 \phi_0^2 / \mathbf{k}^2 \quad (3.60)$$

Keeping in mind identification (3.54) we find that it is exactly the same result which we have found above working in terms of equilibrium distribution with Bose condensate. This finalizes the argument that both descriptions (in both gauges) are equivalent and both states $\phi = \phi_0 \exp(imt)$ and $A_0 = 0$ and $\phi = \phi_0$ and $A_0 = m_B/e$ describe the same collection of particles at rest.

3.4 Friedel oscillations in fermionic plasma

We consider here the Friedel oscillations in fermionic plasma. The non-relativistic case is discussed in reference [55; 56; 81], both at zero and non-zero temperatures. The relativistic case was studied in [81]. In what follows all four cases are presented, considered in somewhat different way.

Singularities of $\Pi_{00}(k)$ in the complex k -plane appear when the singular points of the integrand in equation (3.22) in the complex q -plane pinch the contour of integration or

coincide with the integration limit at $q = 0$. The usual calculation is done at zero temperature when the fermion distribution tends to theta-function and hence the integral over dq goes from zero to the Fermi momentum, q_f . The singularity in Π_{00}^F appears when the branch points of the logarithm at $k = \pm 2q$ move to the integration limit at $q = q_F$. In more general case of arbitrary temperature the integrand is a smooth function of q and integration goes up to infinity. The integrand has two kinds of singularities. First, there are poles in the distribution function f_F which are situated at

$$q_n^2 = [\mu \pm i\pi T(2n + 1)]^2 - m_F^2, \quad (3.61)$$

where n runs from 0 to infinity.

The second type of singularities are branch points of the logarithm at

$$q_b = \pm k/2. \quad (3.62)$$

The singularities of $\Pi_{00}(k)$ are situated at such k_n for which q_n and q_b coincide, $q_n = q_b$ and the poles, q_n , and branch points, q_b approach the integration contour in q -plane from the opposite sides. Since, according to the discussion in the previous section and equation (3.47), we consider k in the first quadrant of the complex k -plane, only the singularities with $\Re k \geq 0$ and $\Im k \geq 0$ contribute to the asymptotics of the potential, i.e.

$$k_n = 2q_n = [(\mu + i\pi T(2n + 1))^2 - m_F^2]^{1/2}. \quad (3.63)$$

Symbolically the integral in the r.h.s. of equation (3.47) can be written as a sum of three contributions:

$$I_0 = \int_0^\infty [idk] + 2\pi i \sum [Res] + \sum_n \int_{k_n}^{k_n+i\infty} \Delta, \quad (3.64)$$

where the first integral goes along the positive imaginary axis in k -plane, the second one is the sum of the residues of the poles on the integrand (if the poles are on the imaginary axis, only a half of the residue is to be taken), and the third term is the integral of the discontinuity over the branch line of the logarithmic singularity of $\Pi_{00}(k)$. The integration contour in complex k -plane is schematically depicted in figure 3.1, where only one pole and one branch-cut are included.

Before calculating the singular part of Π_{00} let us first note that we are interested only in singularities in the first quadrant in k -plane and thus only contribution from $-\ln|2q - k|$ should be taken. Since the absolute value of the argument can be written as the limit of $\epsilon \rightarrow 0$ of $|2q - k| = [(2q - k)^2 + \epsilon^2]^{1/2}$, the logarithmic contribution into

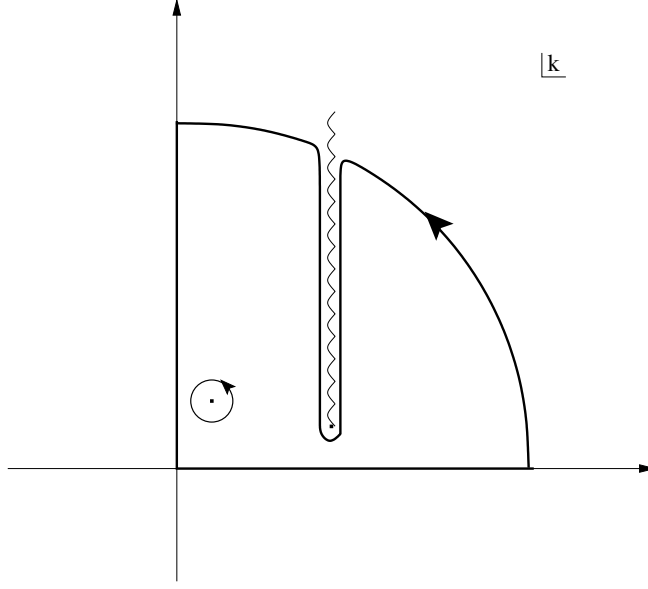

Figure 3.1: Contour of integration in complex k -plane.

$U(r)$ is given by

$$\begin{aligned} \ln \left| \frac{k+2q}{k-2q} \right| \rightarrow -\ln |k-2q| &= -[\ln(k-2q+i\epsilon) + \ln(k-2q-i\epsilon)]/2 \\ &\rightarrow -\ln(k-2q-i\epsilon)/2. \end{aligned} \quad (3.65)$$

The singular part $\Pi_{00}^{(n)}$ near k_n can be determined as follows. The integral along the contour squeezed between q_n and q_b is equal to the residue of the integrand at the pole multiplied by $2\pi i$ plus a regular part at $k = k_n$. The pole term near $q = q_n + z$ is equal to

$$\frac{1}{\exp[(E_n - \mu)/T] + 1} = -\frac{E_n T}{z q_n}. \quad (3.66)$$

The residue in the pole gives the singular term in Π_{00} equal to:

$$\Pi_{00}^{(n)}(k) = -\frac{ie^2 T}{4\pi k} (4E_n^2 - k^2) \ln(k - 2q_n - i\epsilon), \quad (3.67)$$

where q_n is the pole position given by equation (3.63) and $E_n = \sqrt{q_n^2 + m^2}$. We have neglected here the contributions of antiparticles assuming that the chemical potential is sufficiently large. The discontinuity of Π_{00} at the branch line $k = 2q_n + iy$, where y

runs from zero to infinity, is equal to

$$\Delta\Pi_{00}^{(n)} = -\Pi_{00}^{(n)+} + \Pi_{00}^{(n)-} = \frac{e^2 T(4E_n^2 - k^2)}{2k}, \quad (3.68)$$

where upper index " + " or " - " indicate that the value of Π_{00} is taken on the right or the left hand side of the cut.

The contribution of this discontinuity into the asymptotic behavior of $U(r)$, equation (3.47), is equal to:

$$U_n(r) = \frac{Q}{2\pi^2 r} \mathcal{J}m \int_0^\infty \frac{id y k \exp(-y r + 2i q_n r) (\Delta\Pi_{00})}{\left[k^2 - \Pi_{00}^{(n)+}(k) \right] \left[k^2 - \Pi_{00}^{(n)-}(k) \right]}. \quad (3.69)$$

Here $k = 2q_n + iy$. For fermionic plasma we can neglect y in comparison with q_n because in the limit of large distances $y \sim 1/r$. However in the bosonic case a non-vanishing contribution comes from sub-dominant in y terms, see below.

Below we consider separately relativistic and non-relativistic cases. In relativistic limit $E_n = q_n$ and the factor in front of logarithm, equation (3.67), and discontinuity (3.68) vanish at the branch point and the discontinuity becomes purely imaginary in the leading order, $\Delta\Pi_{00}^{(n)} = -ie^2 T y$. This leads to a faster decrease of the screened potential in comparison with non-relativistic case, $1/r^4$ instead of $1/r^3$, and to the change of phase, $\sin(2\mu r)$ instead of $\cos(2\mu r)$.

Relativistic limit In relativistic case, when $m \ll T$ but μ may be large, the poles are situated at:

$$E_n = q_n = \mu \pm i\pi T(2n + 1). \quad (3.70)$$

Since $|k|^2 > 4|q_n|^2 > 4(\mu^2 - m_F^2)$, then for sufficiently large μ , $\mu > m_F$, and low T we can neglect $\Pi_{00} \sim e^2 \mu^2$ in the denominator in comparison with $4q_n^2$ and obtain:

$$U_n(r) = \frac{Q e^2 T}{16\pi^2 q_n^3 r^3} \mathcal{J}m e^{2i q_n r} = \frac{Q e^2 T}{16\pi^2 q_n^3 r^3} \sin(2\mu r) e^{-2\pi(2n+1)Tr}. \quad (3.71)$$

For non negligible T the dominant term is that with $n = 0$ and though it decreases exponentially, the power of the exponent may be much smaller than the standard one, equation (1.44) with $m_D = e\mu/\pi$, as follows from equation (3.29).

At small T the result is proportional to the temperature and thus formally vanishes at $T = 0$. However, at small T the total contributions of the branch points diverges as

$1/T$, so summing up all U_n we find

$$U_{cut} = \sum_{n=0}^{\infty} U_n = \frac{e^2 Q T}{16\pi^2 r^3 \mu^3} \frac{\sin(2\mu r) \exp(-2\pi r T)}{1 - \exp(-4\pi r T)}. \quad (3.72)$$

For $T \rightarrow 0$ and large r we can take $q_n = \mu$ because the effective n 's are of the order of $n_{eff} \sim 1/(4\pi r T)$ and $nT \sim 1/r \ll \mu$.

For very small T such that $rT \ll 1$ we obtain:

$$U_{cut} = \frac{e^2 Q}{64\pi^3} \frac{\sin(2\mu r)}{r^4 \mu^3}, \quad (3.73)$$

in agreement with reference [81]. However, if $rT \geq 1$, then, as we mentioned above, the screened potential decays exponentially similar to normal Debye screening with an important difference that the screening mass does not contain the electromagnetic coupling, e . On the other hand, the magnitude of the screened potential is proportional to e^2 . So formally for $e = 0$ the oscillating potential vanishes, while the Debye one tends to the vacuum Coulomb expression.

The ratio of the main term in the potential at $T \neq 0$ to that at $T = 0$ is equal to:

$$\frac{U(r, T)}{U(r, T = 0)} = \frac{4\pi r T e^{-2\pi r T}}{1 - e^{-4\pi r T}}. \quad (3.74)$$

It is always smaller than unity. i.e. the screening is weakest at $T = 0$.

Non relativistic limit Let us turn now to non relativistic limit, when $m_F \gg T$, $\mu - m_F \ll m_F$, and for simplicity $\tilde{\mu} = \mu - m_F \gg T$. The calculations go along the same lines with evident modifications. The poles of the distribution function f are located at

$$q_n = [(\mu^2 - m_F^2) + 2i\pi\mu T(1 + 2n)]^{1/2} \approx \sqrt{2m_F \tilde{\mu}} \left[1 + \frac{i\pi\mu T(1 + 2n)}{\mu^2 - m_F^2} \right], \quad (3.75)$$

The logarithmic singular part of Π_{00} corresponding to this pole is given by the same equation (3.67) and the discontinuity on the cut is given by equation (3.68). An essential difference now is that the discontinuity does not vanish near the branch point, $(4E_n^2 - 4q_n^2) = 4m_F^2 \neq 0$:

$$\Delta\Pi_{00} \approx -e^2 T m_F^2 / k. \quad (3.76)$$

Thus the contribution of the n -th pole into the screened potential is equal to:

$$U_n(r) = \frac{e^2 Q T m_F^2}{\pi^2 r} \mathcal{J}m \int_0^\infty \frac{idy \exp(2iq_n r - yr)}{\left[k^2 - \Pi_{00}^{(n)+}(k) \right] \left[k^2 - \Pi_{00}^{(n)-}(k) \right]}. \quad (3.77)$$

Here, as in the relativistic case above, $k = 2q_n + iy$. Neglecting k^2 in comparison with Π_{00} , see equation (3.29) and discussion below equation (3.70), we obtain:

$$\begin{aligned} U_n(r) &= \frac{Q e^2 T m_F^2}{16 \pi^2 q_n^4 r^2} \mathcal{J}m \left[i e^{2iq_n r} \right] \\ &= \frac{Q e^2 T}{64 \pi^2 r^2 \tilde{\mu}^2} \cos(2\sqrt{2m_F \tilde{\mu}} r) \exp \left[-2\pi(2n+1) \frac{r T \mu}{\sqrt{2m_F \tilde{\mu}}} \right]. \end{aligned} \quad (3.78)$$

If temperature is not extremely small, the term with $n = 0$ gives the slowest decreasing part of the potential, but for $T \rightarrow 0$ we need to take into account the whole sum $U_{cut}(r) = \sum U_n(r)$:

$$U_{cut}(r) = \frac{Q e^2 T m_F^2}{64 \pi^2 r^2 \tilde{\mu}^2} \cos \left(2\sqrt{2m_F \tilde{\mu}} r \right) \frac{\exp \left(-\pi r T \sqrt{2m_F / \tilde{\mu}} \right)}{1 - \exp \left(-2\pi r T \sqrt{2m_F / \tilde{\mu}} \right)}. \quad (3.79)$$

Asymptotically for large r but $2\pi r T \sqrt{2m_F / \tilde{\mu}} < 1$ the potential tends to

$$U_{cut}(r) = \frac{Q e^2 m_F \cos(2q_F r)}{64 \pi^3 r^3 q_F^3}, \quad (3.80)$$

where $q_F = \sqrt{2\tilde{\mu}m_F}$. The result agrees with that presented in reference [81]. The potential in equation (3.79) is plotted in figure 3.2 as a function of distance r and temperature T for $m_F = 0.5$ MeV and $\mu_F = 0.55$ MeV. Temperatures vary from 10^{-4} MeV and 10^{-2} MeV, which corresponds to $(1.16 \cdot 10^6 - 1.16 \cdot 10^8)$ K. Distances vary from 1 MeV $^{-1}$ to 100 MeV $^{-1}$, corresponding to $(2 \cdot 10^{-11} - 2 \cdot 10^{-9})$ cm. The main features for the plot in the relativistic case are similar to the non-relativistic one.

Note in conclusion that above we have neglected Π_{00} in comparison with $4q_n^2$. It is justified for sufficiently small e^2 . Otherwise one has to calculate the integral more accurately taking into account the mild logarithmic singularity in Π_{00} which goes to infinity at the branch point for non-relativistic fermions and goes to zero for relativistic ones.

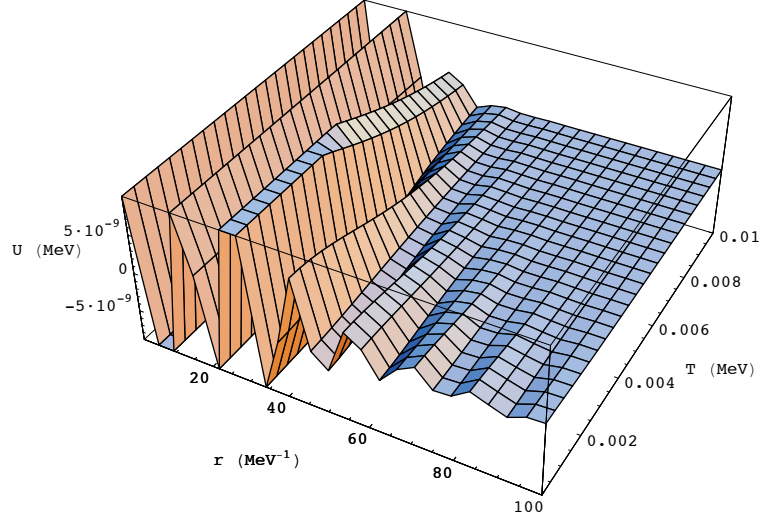

Figure 3.2: *Friedel oscillations for massive fermions - see equation (3.79) - with $m_F = 0.5$ MeV, $\mu_F = 0.55$ MeV. Temperatures are in MeV and distances in MeV^{-1} . The exponential damping at large distance and/or temperature, as well as oscillations as a function of the distance r , can be seen.*

3.5 Screening in bosonic plasma

As we have already mentioned the photon polarization tensor in presence of Bose condensate is infrared singular, having at small k form (3.43). The terms $\sim 1/k^2$ have been found in refs. [9; 12], while $1/k$ -term, which vanishes at $T = 0$, has been found in reference [9]. Because of $1/k^2$ term the pole of the photon Green's function shifts from imaginary axis in contrast to the usual Debye case when the pole is purely imaginary. Due to its real part the screened potential acquires an oscillating factor superimposed on the exponential decrease [4; 9]. The position of poles in integral (3.47) are given by the equation $k^2 - \Pi_{00}(k) = 0$, which is convenient to write as:

$$k^2 + e^2 \left(m_0^2 + \frac{m_1^3}{k} + \frac{m_2^4}{k^2} \right) = 0, \quad (3.81)$$

where

$$m_0^2 = \frac{C}{(2\pi^3)m_B} + h(T) + m_D^{(F)2}(T, \mu_F), \quad (3.82)$$

$$m_1^3 = \frac{m_B^2 T}{2}, \quad (3.83)$$

$$m_2^4 = \frac{4m_B C}{(2\pi)^3}, \quad (3.84)$$

where $h(T)$ is defined in equation (3.44) and $m_D^{(F)}$ is the fermionic Debye mass. For relativistic fermions it is given by equation (3.29) and for non-relativistic ones by equation (3.34). If plasma is electrically neutral because of the mutual compensation of bosons and fermions, the chemical potential of fermions is expressed through the amplitude of Bose condensate and $\mu_B = m_B$. However, one can imagine the case when there are two types of charged bosons and neutrality is achieved by the opposite charge densities of these bosons. In such plasma the fermionic Debye mass is zero.

In what follows we analyze different contributions to the electrostatic potential $U(r)$ for different limiting values of the parameters. In particular, we consider the contributions from the poles in integral (3.47), from the imaginary axis, which arises when the integrand in equation (3.47) is not an even function of k and from integration along the branch cuts of the logarithmic terms in Π_{00} , see equation (3.38). The integration contour is similar to that for fermions, figure 3.1 but the positions of the poles are evidently shifted, see the following subsection.

3.5.1 Contribution from poles

At low temperatures the four roots of equation (3.81) are given by:

$$k_{1,2,3,4} = \pm \frac{i}{\sqrt{2}} \left[e^2 m_0^2 \pm \sqrt{e^4 m_0^4 - 4e^2 m_2^4} \right]^{1/2}. \quad (3.85)$$

As is mentioned above, we are interested only in the poles in the first quadrant in the complex k -plane. If $e^4 m_0^4 > 4e^2 m_2^4$, all the poles are purely imaginary and the Coulomb potential is screened exponentially, similar to the usual Debye situation. The poles on the positive imaginary axis are situated at

$$k_{1,2} = \frac{iem_0}{\sqrt{2}} \left(1 \pm \sqrt{1 - 4m_2^4/e^2 m_0^4} \right)^{1/2}. \quad (3.86)$$

The contribution of these poles into the potential is

$$U(r) = \frac{Q}{4\pi r} \frac{k_1^2 e^{ik_1 r} - k_2^2 e^{ik_2 r}}{k_1^2 - k_2^2}. \quad (3.87)$$

In the limit of small ratio m_2^2/em_0^2 the potential becomes:

$$U(r)_{pole} \approx \frac{Q}{4\pi r} \left[\exp \left(-em_0 r \left(1 - \frac{m_2^4}{2e^2 m_0^4} \right) \right) - \frac{m_2^4}{e^2 m_0^4} \exp \left(-m_2^2 r/m_0 \right) \right]. \quad (3.88)$$

Thus for a small m_2 the screening, though exponential, can be much weaker than the usual Debye one.

In the opposite case, $e^4 m_0^4 < 4e^2 m_2^4$, the poles acquire real part and now only one pole is situated in the first quadrant. The potential oscillates around the exponentially decreasing envelope [4; 9]. The result is especially simple in the limit of large m_2 :

$$U(r)_{pole} = \frac{Q}{4\pi r} \exp\left(-\sqrt{e/2} m_2 r\right) \cos\left(\sqrt{e/2} m_2 r\right). \quad (3.89)$$

More interesting situation is realized at larger temperatures, when the term m_1^3/k in the polarization operator, equation (3.81) is non-negligible. The contribution of the poles into the asymptotics of the screened potential is similar to the above considered case of low T if m_2 dominates in Π_{00} , but for a small m_2 , e.g. if $C = 0$, the poles are situated at $k = e^{2/3}(-1)^{1/3}(m_B^2 T/2)^{1/3}$. The potential exponentially decreases at large distances but the power of the exponent is proportional to temperature and at small T the decrease of $U(r)$ may be rather weak.

3.5.2 Contribution from the integral along the imaginary axis

Because of the odd term, m_1^3/k , in the polarization operator the imaginary part of integral (3.47) along the imaginary axis in the complex k -plane is non-zero and the screened potential drops as a power of r :

$$U(r) = -\frac{Qe^2 m_1^3}{2\pi^2 r^2} \int_0^\infty \frac{dz \exp(-z)}{[-(z/r)^2 + e^2(m_0^2 - m_2^4 r^2/z^2)]^2 + e^4 m_1^6 r^2/z^2}. \quad (3.90)$$

The previous expression has been obtained by substituting $k = iy$ and then $z = yr$. If $m_2 \neq 0$ the dominant term at large r behaves as

$$U(r) = -\frac{12Qm_1^3}{\pi^2 e^2 r^6 m_2^8}. \quad (3.91)$$

However, if the temperature is not zero and the bosonic chemical potential reaches its upper limit, $\mu = m_B$, but the condensate is not yet formed, the term proportional to m_1 dominates and the asymptotic decrease of the potential becomes much slower:

$$U(r) = -\frac{Q}{\pi^2 e^2 r^4 m_1^3} = -\frac{2Q}{\pi^2 e^2 r^4 m_B^2 T}. \quad (3.92)$$

So the formation of the condensate manifests itself by a strong decrease of screening. This effect may be a signal of formation of Bose condensate.

It is interesting that the screened potential is inversely proportional to the fine struc-

ture constant $\alpha = e^2/4\pi$.

3.5.3 Contribution from the logarithmic branch cuts

Let us estimate now the effects of the logarithmic singularities of Π_{00} on the asymptotics of the screened potential (analogue of the Friedel oscillations). Technically the calculations are similar to those made in section 3.4 but the results are noticeably different. We assume here that the chemical potential of bosons reaches its maximum value, $\mu = m_B$. For smaller μ there is not much difference between bosons and non-degenerate fermions, while for $\mu = m_B$ new phenomena arise, which are absent for fermions.

The poles in the integrand of equation (3.38), which lead to the singularities of $\Pi_{00}(k)$ in the first quadrant of the complex k -plane, are situated at

$$q_n = (4i\pi n T m_B)^{1/2} (1 + i\pi n T/m_B)^{1/2}. \quad (3.93)$$

Here n runs from 1 to infinity, because there is no pole at $q = 0$ since the numerator of the integrand is proportional to q^2 .

The singularities in $\Pi_{00}(k)$ are situated at such k where the singularities of the integrand in equation (3.38) pinch the integration contour, i.e. as above, at $k_n = 2q_n$. The singular part of Π_{00} is calculated in the same way as it has been done for fermions and is equal to the residue of the integrand:

$$\Pi_{00}^{(n)B} = \frac{ie^2 T E_n^2}{2\pi k} \ln \left(\frac{k - 2q_n - i\epsilon}{k + 2q_n + i\epsilon} \right), \quad (3.94)$$

where $E_n = \sqrt{q_n^2 + m_B^2}$.

The discontinuity of this term across the logarithmic cut is $\Delta \Pi_{00}^{(n)B} = e^2 T E_n^2/k$. Correspondingly the contribution of this singularity into the asymptotics of $U(r)$ is given by:

$$U_n^B(r) = \frac{Qe^2 T}{2\pi^2 r} \Re \int_0^\infty \frac{dy E_n^2 e^{2iq_n r} e^{-ry}}{\left[k^2 + \Pi_{00}^{(+)} \right] \left[k^2 + \Pi_{00}^{(-)} \right]}, \quad (3.95)$$

where $k = 2q_n + iy$ and $E_n^2 = q_n^2 + m_B^2$, and Π_{00}^\pm are the values of the polarization tensor on right and left banks of the cut. Note that at $r \rightarrow \infty$ the effective y is small, $y \sim 1/r$.

An important difference between bosonic and fermionic cases is that the position of the pole for fermions, equations (3.70,3.75), does not move to zero when $T \rightarrow 0$, while for bosons $q_n^2 \sim T$. Correspondingly one can neglect Π_{00}^F in comparison with k_n^2 , while it may be an invalid approximation for bosons.

Let us first consider the case of low temperatures when Π_{00} is dominated by the

constant fermionic contribution, $\Pi_{00}^F \approx -m_D^2$, where m_D^2 is given, for instance, by equation (3.29). At large r and non-zero T the logarithmic contribution into the screened potential is essentially given by the first term with $n = 1$:

$$U_1(r) = -\frac{Q\pi^2}{2e^2} \frac{Tm_B^2}{r^2\mu_F^4} \exp\left(-2\sqrt{2\pi m_B T}r\right) \cos\left(2\sqrt{2\pi m_B T}r\right). \quad (3.96)$$

Here we took the relativistic limit for Π_{00}^F . The result is easy to rewrite in non-relativistic case. The potential in equation (3.96) is plotted in figure 3.3. The bosonic chemical potential is taken to be equal to its limiting value, $\mu_B = m_B$, and the boson mass is assumed to be the same as the fermion mass in figure 3.2, $m_B = m_F = 0.5$ MeV. Such a low mass of bosons is chosen simply for illustration. In realistic case charged bosons are much heavier than the charged fermions, though it is not excluded that there exists an unknown gauge symmetry with charged bosons lighter than fermions.

The temperature in figure 3.3 varies from 10^{-4} MeV to 0.1 MeV, corresponding to $(1.16 \cdot 10^8 - 1.16 \cdot 10^9)$ K, while distances vary from 1 MeV $^{-1}$ to 100 MeV $^{-1}$, corresponding to $(2 \cdot 10^{-11} - 2 \cdot 10^{-9})$ cm.

Figure 3.4 shows the same potential but with higher mass for bosons, $m_B = 100$ MeV, that is of the order of the pion mass. The fermion mass and chemical potential are taken the same as above. The temperature varies in the range $10^{-6} - 5 \cdot 10^{-2}$ MeV or $1.16 \cdot 10^4 - 5.8 \cdot 10^8$ K and the distance in $10^{-2} < r(\text{MeV})^{-1} < 10$ corresponding to $2 \cdot 10^{-13} < r(\text{cm}) < 2 \cdot 10^{-10}$. We can see from these figures that if we increase the boson mass, the bosonic potential fades away faster.

In the limit of $T \rightarrow 0$ (analogous to the discussed above Friedel case) we should take the sum $\sum_{n=1}^{\infty} U_n$ because all the terms are of the same order of magnitude and $n_{eff} \sim 1/(4\pi m_B T r^2)$. So we could expect that the sum is inversely proportional to T and the potential is non-vanishing at $T = 0$, the same as in the fermionic case. However, the summation is not so simple as previously because we do not deal now with geometric progression, $\exp(-an)$ but with more complicated function, $\exp(-b\sqrt{n})$. Since the effective values of n are big, we can express the sum as an integral and obtain, in the leading approximation $\Pi_{00} = m_D^2$, that the potential is proportional to the temperature T and hence vanishes:

$$U(r)^B = -\frac{QT\pi^2}{2e^2r^2\mu_F^4} \text{Re} \sum_{n=1}^{\infty} E_n^2 e^{2iq_n r} \approx -\frac{QT\pi^2}{2e^2r^2\mu_F^4} \text{Re} \int_1^{\infty} dn E_n^2 e^{2iq_n r} \sim T. \quad (3.97)$$

The real part of the integral $\int_1^{\infty} dn e^{2iq_n r}$ written above is equal to:

$$\frac{\exp(-2\sqrt{2\pi T m r})}{4r} \left[\sqrt{\frac{2}{\pi m T}} \left(\cos(2\sqrt{2\pi T m r}) - \sin(2\sqrt{2\pi T m r}) \right) - \frac{1}{2\pi m r T} \sin(2\sqrt{2\pi T m r}) \right],$$

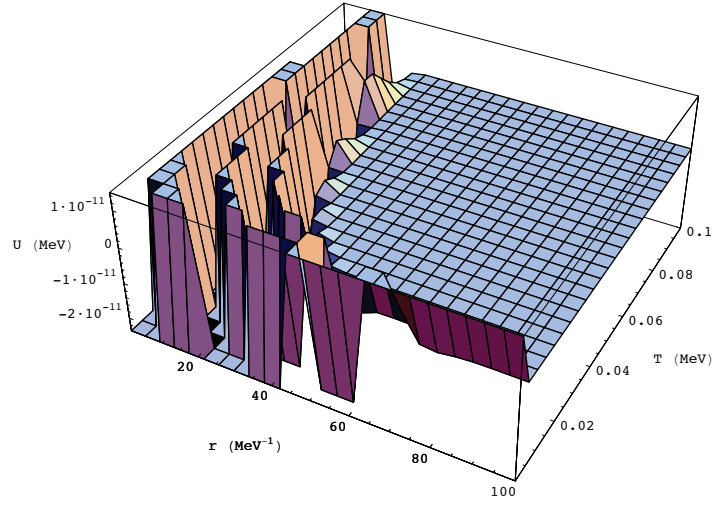

Figure 3.3: Oscillation of the electrostatic potential in presence of bosonic plasma, see equation (3.96). The boson mass is equal to the fermion one in Figure 3.2, $m_B = 0.5\text{MeV}$ and the chemical potential is $\mu_B = m_B$. Temperatures are in MeV and distances in MeV^{-1} .

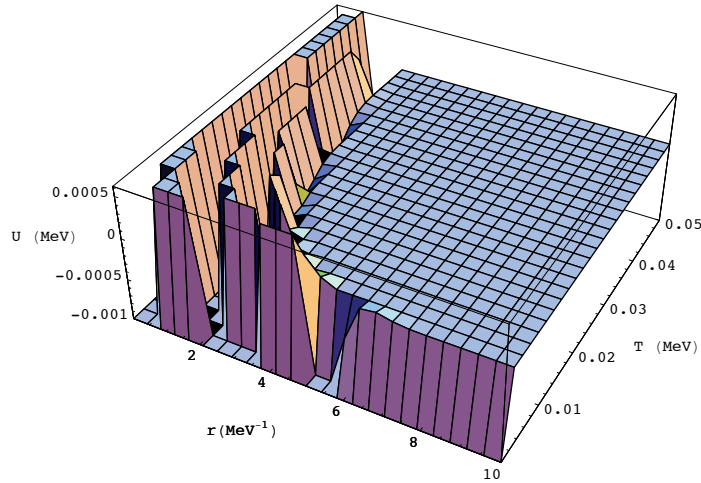

Figure 3.4: Oscillation of the electrostatic potential in presence of bosonic plasma - see equation (3.96). The boson chemical potential is equal to its mass, $\mu_B = m_B = 100\text{MeV}$. Temperatures are in MeV and distances in MeV^{-1} . In the picture are evident the oscillations due to both the temperature T and the distance r as well as the exponential damping in both the directions.

that goes to the constant value -1 in the $T \rightarrow 0$ limit. So the whole expression in equation (3.97) is proportional to T .

It is important to stress that the previous result is valid in the limit $Tm_B r^2 \ll 1$, which means that it is applicable at small distances $r_B \ll 1/\sqrt{m_B T}$. On the other hand at large distances r and non vanishing T one should consider the expression in equation (3.96) which is similar to the fermionic Friedel term in equation (3.79) but has different dependence on the coupling constant e since it goes like e^{-2} , while Friedel oscillations go like e^2 . Hence we have non analytic dependence on the coupling constant e in presence of bosons. Similar dependence on e^{-2} was found in section 3.5.2.

There are also differences arising from the fact that in the limit $T \rightarrow 0$ the poles of the boson distribution function go to zero, see equation (3.93), while the poles of the fermion distribution function tend to the non vanishing value q_F , see equation (3.61). Hence Friedel oscillations for fermions start from their maximum amplitude at $T = 0$ and then exponentially decrease with temperature, while for bosons the effect vanishes at $T = 0$, then linearly increases with T and finally exponentially decreases. Another consequence is that the argument of the oscillating cosine function depend on T for bosons but not for fermions. Hence the boson potential does not oscillate at small temperatures.

At high fermionic chemical potential μ_F and small temperature T , the boson oscillations typically go to 0 at smaller distances than the fermionic ones, which are observable at distances $r \leq T$. On the other hand lowering the boson mass m_B the exponential damping is weaker but at the same time oscillations fade away.

If the condensate is formed, Π_{00} would be dominated by the singular term $e^2 m_2^4 / k^2$ and according to equation (3.95) the contribution of n -th branch point into the screened potential becomes:

$$U_n^B(r) = -\frac{QTm_B^2}{2\pi^2 e^2 m_2^8 r^2} \mathcal{R}e [k_n^4 e^{ik_n r}]. \quad (3.98)$$

Again, at large r and non zero T the $n = 1$ term is dominant. It oscillates and exponentially decreases according to equation (3.96). However, the sum $\mathcal{R}e \sum_n U_n^B$ vanishes as above, equation (3.97). Probably the vanishing of $U^B(r)$ at small T in the leading order is a more general feature. At least the sub-leading (at small T) terms in k_n and in Π_{00} vanish as well. If we take into account the imaginary part of Π_{00} due to the logarithmic cut, the result still remains proportional to a power of temperature after summation. On the other hand, as we see below, in absence of condensate the potential not only survives at $T \rightarrow 0$ but rises as an inverse power of T .

Let us turn now to a more interesting though probably less realistic case when fermions are absent in the plasma, chemical potential of bosons is maximally allowed,

$\mu_B = m_B$ but the condensate is not formed. In the standard model a neutral system has necessarily a fermionic component because fermions are lighter than bosons. Anyway we can imagine systems where the electric charge is compensated by other heavier bosons which do not condense or models with extra $U(1)$ sector and different particle content. In this situation fermions may be absent. Under these conditions Π_{00} vanishes when $T \rightarrow 0$. The position of the branch points of the logarithm $k_n = 2q_n$ also tend to zero and the screening due to logarithmic discontinuity may be non-vanishing at $T = 0$. Indeed, let us turn again to equation (3.95). The integral goes along the contour $k = k_n + iy$ and $y \sim 1/r$ is very small. We assume that $r > 1/\sqrt{Tm_B}$. Thus $k^2 \approx k_n^2 = 16i\pi n T m_B$. Let us now estimate Π_{00} at $k = k_n$. At small temperatures, when $z^2 \equiv (E_B - m_B)/T \approx q^2/(2m_B T)$, Π_{00} can be presented as:

$$\Pi_{00}(k) = -\frac{e^2 m_B^2 T}{\pi^2 k} \int \frac{dz z}{\exp(z^2) - 1} \ln \left| \frac{\sqrt{8m_B T} z + k}{\sqrt{8m_B T} z - k} \right|. \quad (3.99)$$

Notice in passing that if $k < \sqrt{8m_B T}$, then Π_{00} behaves as m_1^3/k in agreement with equations (3.81,3.83), while at large k , $k > \sqrt{8m_B T}$, it has the following asymptotic behavior:

$$\Pi_{00}(k) \approx -\frac{\sqrt{2} e^2 m_B^{5/2} T^{3/2} \zeta(3/2)}{\pi^{3/2} k^2}, \quad (3.100)$$

where $\zeta(3/2) \approx 2.6$. The singular part of Π_{00} , equation (3.94), at $k = k_n + iy$ is equal to

$$\Pi_{00}^{(+)}(k_n + iy) = \frac{i^{1/2} e^2 T^{1/2} m_B^{3/2}}{8\pi^{3/2} n^{1/2}} \left[\ln(y/8\sqrt{\pi n m_B T}) + i\pi/2 \right]. \quad (3.101)$$

For $\Pi_{00}^{(-)}$ the last factor is changed to $(\ln y/8\sqrt{\pi n m_B T} - 3i\pi/2)$. The factor in the denominator of the logarithm comes from $|k + 2q_n| = 4|q_n|$ in equation (3.94).

The screened potential (3.95) at large distances, i.e. for $8\pi T m_B r^2 > 1$, is dominated by $n = 1$. One can check that $|\Pi_{00}(k_1)| > |k_1^2|$, so the latter can be neglected in the denominator of equation (3.95). Keeping in mind that we will use the result below for arbitrary n for which $|\Pi_{00}(k_1)| > |k_1^2|$, we write:

$$U_n(r) \approx \frac{32\pi Q n}{e^2 m_B r^2} \Re e \left[i e^{2iq_n r} \int_0^\infty \frac{dx e^{-x}}{\ln^2(x/8\sqrt{m_B \pi n T} r) - i\pi \ln(x/8\sqrt{m_B \pi n T} r) + 3\pi^2/4} \right], \quad (3.102)$$

where $x = yr$. For large logarithm the leading part of the integral can be approximately evaluated leading to the result:

$$U_1(r) = -\frac{32\pi Q}{e^2 m_B r^2} \frac{e^{-2\sqrt{2\pi T m_B} r}}{\ln^2(8\sqrt{\pi m_B T} r)} \sin(2\sqrt{2\pi T m_B} r). \quad (3.103)$$

Note that $U_1(r)$ is inversely proportional to the electric charge and formally vanishes at $T \rightarrow 0$, but remains finite if $\sqrt{Tm_B r}$ is not zero.

For smaller distances, or such small temperatures that $8\pi Tm_B r^2 \ll 1$, all n up to $n_{max} \sim 1/(8\pi Tm_B r^2)$ make comparable contributions. Thus we have to sum over n . If $n_{max} \gg 1$ the sum can be evaluated as an integral over n . Now, for large n , $k_n^2 \sim n$ and may be comparable to $\Pi_{00}(k_n)$ which, according to equation (3.101), drops as $1/\sqrt{n}$. $\Pi_{00}(k_n)$ would be smaller by magnitude than k_n^2 for

$$n > n_0 \approx 10^{-3} (m_B/T)^{1/3} \ln^{2/3} \left(\sqrt{8m_B T r^2} \right). \quad (3.104)$$

This condition makes sense if $n_0 < n_{max}$ or $r \ln^{1/3}(\sqrt{8m_B T r^2}) < 5/(Tm_B^2)^{1/3}$. For larger r we return to domination of Π_{00} . We should check that the condition

$$r \ln^{1/3}(\sqrt{8m_B T r^2}) > 5/(Tm_B^2)^{1/3} \quad (3.105)$$

does not contradict the condition of large n_{max} . The latter reads

$$r < 1/\sqrt{8\pi Tm_B}. \quad (3.106)$$

If we neglect the logarithmic factor, both conditions would be compatible for $T/m_B < 4 \cdot 10^{-9}$. Thus both cases of dominant $\Pi_{00}(k_n)$ or k_n^2 can be realized depending upon relation between r , T , and m_B .

Let us consider smaller temperatures when $|\Pi_{00}(k_n)| > |k_n^2|$. The potential in the limit of small $\pi Tm_B r^2$ is equal to

$$U(r) = \frac{32\pi Q}{e^2 m_B r^2} \text{Im} \left[\sum_n n e^{2iq_n r} \frac{\ln^2(\sqrt{8m_B T r}) + i\pi \ln(\sqrt{8m_B T r}) + 3\pi^2/4}{(\ln^2(\sqrt{8m_B T r}) + 3\pi^2/4)^2 + \pi^2 \ln^2(\sqrt{8m_B T r})} \right]. \quad (3.107)$$

Since the sum

$$\sum_n n e^{2iq_n r} \approx 2 \int d\eta \eta^3 e^{4i\sqrt{i\pi Tm_B r} \eta} \approx -\frac{12}{256\pi^2 T^2 m_B^2 r^4}, \quad (3.108)$$

where $\eta = \sqrt{n}$, is real in leading order in $1/(16\pi Tm_B r^2)$, a non-vanishing contribution comes from the imaginary part of the numerator of the integrand and we obtain for the analogue of Friedel oscillations in purely bosonic case:

$$U(r) \approx -\frac{3Q}{2e^2 T^2 m_B^3 r^6 \ln^3(\sqrt{8m_B T r})}. \quad (3.109)$$

The result has some unusual features. First, the potential decreases monotonically without any oscillations. Second, it is inversely proportional to the temperature, so the

smaller is T , the larger is the potential. However, the effect exists for sufficiently small r , $r \ll 1/\sqrt{16\pi T m_B}$, i.e. if $T = 0.1\text{K}$ and $m_B = 1\text{GeV}$ the distance should be bounded from above as $r \ll 3 \cdot 10^{-8}$ cm. Another obstacle to realization of such screening behavior is that with fixed charge asymmetry Bose particle should condense and the dominant term in Π_{00} becomes $4m_B C/(2\pi)^3$. In this conditions we arrive to potential (3.98) which vanishes at $T = 0$.

3.6 Discussion of the results

In this chapter of the thesis we have analyzed electromagnetic interactions in plasma with charged scalar bosons and spin one half fermions. In particular, medium effects in the presence of a BEC have been considered.

The calculations have been done in the lowest order in the electromagnetic coupling constant, e , using a slightly different technique with respect to the standard ones, that is either imaginary time method or real time method. Instead, we simply solved perturbatively the operator equations of motion for the charged fields Φ . This approach is safe for abelian massive theories, where the usual infrared singularities do not appear.

The solution in the lowest order has the form

$$\Phi_1(x) = \int dy G(x-y) \mathcal{J}(\Phi_0), \quad (3.110)$$

where $\Phi_{0,1}$ are the charged fields in zeroth and first approximation in e respectively and \mathcal{J} is the current entering the equation of motion. This solution was substituted into the Maxwell equation for the quantum electromagnetic field and the average of quantum operators Φ_0 was taken over the medium. In this way the effect of medium for arbitrary occupation numbers of the charged particles (not necessary equilibrium) can be taken into account. We checked our results comparing them with the known cases of Debye screening and the plasma frequency at low and high T and nonzero chemical potentials.

Then, we considered the polarization operator in the presence of a BEC of charged scalar particles. Physically such a condensate can be formed if there is a significant asymmetry between charged fermions (electrons and positrons). Assuming that the global charge of the plasma is zero (though it is not necessarily so) we can find the number density of charged scalars in the condensate. To this end the charge asymmetry between fermions must be sufficiently large so that the maximum allowed chemical potential of bosons, $\mu_B = m_B$ is not enough to secure the vanishing of total charge. The necessary neutralization can be achieved by the charge density of the condensate, having the distribution $f_c = C\delta(\mathbf{q})$.

The corresponding correction to the polarization operator has a singularity, i.e. a

pole at zero three-momentum of photon, $\sim 1/k^2$. Probably the origin of this singularity is a large mobility of particles with zero momentum under the influence of an external electric field. Energetic particles are much less “eager” to screen the test charge.

Because of these infrared singular terms, the Debye screening length becomes parametrically shorter, $\lambda_D \sim 1/\sqrt{e}$ (if $C \neq 0$), instead of the standard one $\lambda_D \sim 1/e$ which is true for the plasma of charged fermions and/or bosons with $\mu_B < m_B$. It is noteworthy that the Debye screening is now a non-analytic function of the electromagnetic coupling e . The screened electrostatic potential in the presence of Bose condensate of charged scalars has an oscillating behavior superimposed on the exponential decrease, equation (3.89).

At non-zero temperature and $\mu = m_B$ the polarization operator obtains an odd contribution with respect to the transformation $k \rightarrow -k$. As a consequence, the integral along the imaginary axis in the complex k -plane, which determines the asymptotic behavior of $U(r)$, becomes non-vanishing. It leads to a weaker, power law, decrease of the screened potential, which is inversely proportional to the electromagnetic coupling constant squared, equation (3.90). When the condensate has not yet been formed, there is a monotonic power law screening $U \sim 1/r^6$, equation (3.91). Such a change in the screening may be a signal of the condensate formation.

We have also considered the BEC analogue of the fermionic Friedel oscillations. Friedel oscillations arise from the pinching of the integration contour in the complex k -plane by the logarithmic branch point of Π_{00} and the poles of the distribution functions. For bosons, the origin of the phenomenon is the same but the resulting potential is quite different because the poles of the bosonic distribution move to zero when temperature tends to zero, while the fermionic ones keep a finite value. This leads to completely different behavior of the potential as a function of temperature.

The potential vanishes when T goes to zero for mixed bosonic and fermionic plasma. In the case that it is dominated by the first pole, for large r and non-zero T , it goes as in equation (3.96) and at small T the exponential screening is quite mild. For purely bosonic plasma the “Friedel” part of the screening is given by equations (3.102) and (3.109). If $Tm_B r^2$ is not small the potential oscillates and exponentially decreases, while for smaller T it does not oscillate and is proportional to $1/(e^2 T^2)$. The $1/e^2$ behavior looks puzzling but one should remember that it is an asymptotic result for large distances. However, if we take the formal limit $e \rightarrow 0$ the screening would disappear together with e . Similar reasoning is applicable to $1/T^2$ behavior: this is true only for large but simultaneously sufficiently small distances $r < 1/\sqrt{16\pi m_B T}$, when the k^2 part of the photon Green’s function is sub-dominant.

The system considered in this chapter is standard electrodynamics plus BEC. The screening effects we described here can be produced, of course, in the framework of the

standard model of particle physics as long as the EW symmetry is broken. A possible realization of this system is in the early universe after the EW symmetry breaking epoch, as we argued in chapter 2. A system analogous to our model may be also realized in white dwarfs, as it was argued in [4; 16]. Finally, it is not excluded that an extension of the minimal standard model will demand stable charged Bose fields. If this is the case, the calculated photon dispersion relation may be of interest in cosmology or in dense stellar environment. For example, we may expect condensation of di-quarks in quark stars. On the other hand, stability of scalars may be irrelevant because even unstable particles may condense in a dynamical equilibrium state.

Bose condensation of charged scalars can possibly be realized also in the following situation. Let there be high temperature plasma of e^\pm , ν , and $\bar{\nu}$ with a considerable excess of e^- over e^+ and of ν over $\bar{\nu}$, i.e. there are large lepton and electric charge asymmetries. We assume that there are also charged pions (or some other scalar particles) in the plasma to ensure zero total electric charge. The condensed scalars may be stabilized by large chemical potentials of neutrinos, such that the decay $\pi^+ \rightarrow e^+\nu$ is not allowed because the Fermi states with $E = m_\pi/2$ are already occupied. Such a state might possibly exist in exotic stars.

Part II

Primordial perturbations and non-Gaussianities.

Chapter 4

Perturbations: the state of the art

4.1 Introduction

It is nowadays clear that cosmology and high energy physics are strictly connected. Any progress in one of the two fields has a large impact on the other. For instance, particle physics can provide models for the early universe, while cosmology provides invaluable informations and constraints on these models.

The earliest direct cosmological probe nowadays available is the primordial nucleosynthesis (BBN), which constrains the properties of the universe when it was at the temperature ~ 1 MeV, that is a few seconds of age - for a review see [44]. BBN is one of the observational pillars of the hot Big Bang model and provides detailed informations on the *homogeneous* universe.

In the homogeneous approximation it is possible to successfully describe the average expansion of the universe on large scales and its cooling down from a hot, radiation-dominated epoch to the present days. But matter and energy are not actually smoothly distributed in the universe. There are complex structures, such as stars, galaxies, clusters of galaxies etc. which are not taken into account in a homogeneous model. Structures were generated by the amplification of small density perturbations in the primeval plasma after the universe became matter dominated.

Informations on the inhomogeneities of the early universe can be extracted from the temperature fluctuations that we observe today in the cosmic microwave background (CMB) radiation. The spectrum of CMB photons is consistent with a black body at $T = 2.7$ K with tiny fluctuations of order $\Delta T/T \sim 10^{-5}$. It is well known that CMB photons have propagated almost freely since matter-radiation equality, that is when the universe was about 380.000 years old, or equivalently, from redshift $z = 1100$. Hence their present distribution is determined by the properties they had on the last scattering surface. CMB temperature fluctuations are closely related to perturbations

in the primeval plasma, hence their properties can be used to test and constrain models of the early universe which produce such perturbations.

Small curvature perturbations can be generated by a very simple mechanism, that is, the stretching to super-Hubble scales of vacuum fluctuations of light scalar fields during a phase of accelerated expansion called inflation. Nevertheless, the details of the generation of perturbations and the corresponding CMB fluctuations in the primordial universe are still unknown.

Although the simplest early Universe models are based on inflation driven by a single scalar field, many models consider additional scalar fields, which can play a dynamical role during inflation or simply be spectator fields (see e.g. [82] for introductory lectures). A strong motivation for considering many fields comes from particle physics, since models beyond the standard one (e.g. SUSY models) typically include a large number of extra fields.

The existence of several degrees of freedom opens up the possibility of isocurvature perturbations, i.e. perturbations in the particle density ratio between two fluids. Since primordial isocurvature perturbations leave distinctive features of the CMB acoustic peaks, they can be in principle disentangled from the usual adiabatic mode.

Since the primordial cosmological perturbations are tiny, they can be studied using a perturbative approach. At first order, linear perturbation theory can be used to analyze the generation and the evolution of fluctuations at a very good level of approximation. The observed power spectrum of linear perturbations can be used to constrain models of the early universe.

It is commonly assumed that the primordial density perturbations have a gaussian distribution, that is, their Fourier components are uncorrelated and have random phases. Under this hypothesis the properties of the distribution function are completely specified by the two-point correlation function, or equivalently, by the power spectrum in Fourier space.

Whether the perturbations are actually fully gaussian or not is still unclear. Single field models of inflation, which are theoretically appealing for their simplicity, produce nearly Gaussian distributions. On the other hand, more complicated inflationary models, such as multi-field models, predict pretty large non-Gaussianities (NG), which are still allowed by observational constraints.

The three-point correlation function, that is the first probe beyond the linear order, can be used to test the second order of perturbation theory and, consequently, NG. It is predicted to be very small in simple one-field inflationary models, but it can be large in more complicated models. The possible existence of non-Gaussian features in the CMB spectrum has received increasing attention in the latest years. A non-vanishing detection of three-point correlation function would be a strong evidence in

support of theoretical models predicting non-Gaussian features in the CMB sky. Hence non-Gaussianity is considered as a key observable to discriminate among competing scenarios for the generation of cosmological perturbations and is one of the primary targets of present and future Cosmic Microwave Background satellite missions.

Given the WMAP data [45], we can conservatively say that present bounds are consistent with vanishing non-Gaussianity. Nevertheless the current CMB data seem to favour a non-zero amount of so-called local NG. This feature may be a hint of non-Gaussian behavior to be further investigated by experiments, such as the European satellite Planck [83]. The upper bounds on primordial NG can be used to constrain early Universe scenarios and, if they will be detected, the amplitude and shape of non-Gaussianities would provide informations on the primordial perturbations.

4.2 Inflation

The word inflation is commonly used to indicate a phase of acceleration which took place in the very early universe, before the beginning of the standard radiation-dominated epoch. Such an accelerated phase was introduced to solve some shortcomings of the standard cosmological model, such as the horizon and flatness problems - for a review see [82; 84; 85; 86]. All these problems can be solved if a phase of acceleration, $\ddot{a} > 0$, was realized in the early universe, during which the causal size was decoupled from the Hubble radius H^{-1} .

From one of the Friedmann equations

$$\frac{\ddot{a}}{a} = -\frac{4\pi G}{3}(\rho + 3P), \quad (4.1)$$

it follows that the cosmic acceleration is realized when $(\rho + 3P) < 0$. Such a condition is, for instance, satisfied by the equation of state of a cosmological constant ($P = -\rho$) but not by radiation ($P = \rho/3$) nor matter ($P = 0$).

The condition $(\rho + 3P) < 0$ can be also realized by using a scalar field ϕ , which enables the accelerating phase to have a finite duration. This is one of the reasons why inflation is typically assumed to be driven by a scalar field, which is dubbed the *inflaton*. It is possible to demonstrate - see the references quoted above for the details - that ϕ can give rise to a period of inflation as long as its energy is dominant in the universe and its kinetic energy is negligible with respect to its potential energy. Quantitatively, inflation is realized as long as the slow-roll conditions:

$$\epsilon \equiv -\frac{\dot{H}}{H^2} \ll 1 \quad \eta \equiv M_P^2 \frac{V''}{V} \ll 1 \quad (4.2)$$

are satisfied, where V is the potential of the scalar field and a prime denotes its derivative with respect to ϕ .

4.2.1 Generation of cosmological perturbations

Inflation is a fundamental ingredient to make the universe as homogeneous and isotropic as we observe it today. Nevertheless, inflation is of crucial importance also for solving another cosmological problem: the generation of primordial perturbations, which were amplified because of the attractive nature of gravity and grew to form all the structures that we observe today. Amplification takes place when the attractive gravitational interaction is stronger than the repulsive pressure in a given system. This is called Jeans instability. The expansion of the universe makes more difficult for perturbations to grow and, clearly, matter dominated regime (MD) is more favorable to this end than the faster expanding radiation dominated (RD) regime. In particular it can be shown - see [82; 84; 85; 86] for the details - that $\delta \equiv \delta\rho/\rho$ is approximately constant in RD (actually, it logarithmically grows), while it grows like the scale factor ($\delta \propto a$) in MD. Of course, the amplification mechanism can only act on pre-existing perturbations. Such primordial perturbations are naturally produced during a period of inflation, while they should be added by hand in the standard cosmological model.

It is well known that each quantum field has quantum fluctuations. The exponential growth of the scale factor that occurred during inflation stretched the wavelengths of the quantum fluctuations up to cosmological scales. When this wavelength becomes larger than the Hubble radius H^{-1} , the amplitude of the perturbation is frozen due to the large friction term $\propto H\dot{\phi}$, which is present in the equation of motion of scalar fields:

$$\ddot{\phi} + 3H\dot{\phi} + V' = 0. \quad (4.3)$$

After the end of inflation, the fluctuations can eventually re-enter the Hubble radius and have wavelengths accessible to the present observations.

Let us discuss now the generation during inflation of primordial perturbations for a generic massless scalar field¹. Let us consider the evolution of this field during a de Sitter stage and analyze how its fluctuations behave. In this section the symbol ϕ is used to simplify the notation, but the fluctuation of the scalar field $\delta\phi$ is actually meant.

Let us first recall that in a de Sitter epoch the Hubble rate H is a constant and the expansion is approximately exponential: $a(t) = \exp(Ht)$. The metric can be written in the simple form:

$$ds^2 = a^2(\tau)[-d\tau^2 + dx^2] \quad (4.4)$$

¹The inflaton is somehow special, as it is discussed briefly at the end of this section.

where we used the conformal time:

$$\tau = \int \frac{dt}{a(t)}, \quad \tau = -\frac{1}{aH} \quad (\text{de Sitter}). \quad (4.5)$$

The action for a massless scalar field is given by:

$$S = \int d^4x \sqrt{-g} \left(-\frac{1}{2} \partial_\mu \phi \partial^\mu \phi \right) = \int d\tau d^3x a^4 \left[\frac{1}{2a^2} \phi'^2 - \frac{1}{2a^2} \vec{\nabla} \phi^2 \right], \quad (4.6)$$

where a prime denotes a derivative with respect to the conformal time τ and $g \equiv \det(g_{\mu\nu})$. By defining a new function

$$u = a\phi, \quad (4.7)$$

the action can be rewritten as:

$$S = \frac{1}{2} \int d\tau d^3x \left[u'^2 - \vec{\nabla} u^2 + \frac{a''}{a} u^2 \right]. \quad (4.8)$$

This action is very close to the one for a Klein-Gordon scalar field in Minkowski space-time, but there appears a negative time-dependent effective mass

$$m_{eff}^2 = -\frac{a''}{a} = -\frac{2}{\tau^2}. \quad (4.9)$$

The field u can be quantized according to the standard procedure of quantum field theory. Hence, the quantum field \hat{u} can be expanded in Fourier modes:

$$\hat{u}(\tau, \vec{x}) = \frac{1}{(2\pi)^{3/2}} \int d^3k \left\{ \hat{a}_{\vec{k}} u_k(\tau) e^{i\vec{k}\cdot\vec{x}} + \hat{a}_{\vec{k}}^\dagger u_k^*(\tau) e^{-i\vec{k}\cdot\vec{x}} \right\}, \quad (4.10)$$

where \hat{a}^\dagger and \hat{a} are the creation and annihilation operators. The equation of motion for u in Fourier space is again of Klein-Gordon type with a time-dependent mass:

$$u_k'' + \left(k^2 - \frac{a''}{a} \right) u_k = 0 \quad (4.11)$$

and its solution in de Sitter can be chosen as:

$$u_k = \sqrt{\frac{1}{2k}} e^{-ik\tau} \left(1 - \frac{i}{k\tau} \right), \quad (4.12)$$

where we are using the natural units $\hbar = 1$. It is now possible to calculate the two point

correlation function and the related spectrum \mathcal{P} of the produced perturbations as:

$$\langle 0 | \hat{\phi}(\vec{x}_1) \hat{\phi}(\vec{x}_2) | 0 \rangle = \int \frac{d^3 k}{(2\pi)^3} e^{i\vec{k} \cdot (\vec{x}_1 - \vec{x}_2)} \frac{|u_k|^2}{a^2} \equiv \int d^3 k e^{i\vec{k} \cdot (\vec{x}_1 - \vec{x}_2)} \frac{\mathcal{P}_\phi(k)}{4\pi k^3}. \quad (4.13)$$

It follows that, in the limit $k|\tau| \ll 1$, i.e. when the wavelength is larger than the Hubble radius,

$$\mathcal{P}_\phi(k) \simeq \left(\frac{H}{2\pi} \right)^2 \quad (k \ll aH). \quad (4.14)$$

In the analysis above we have assumed that the geometry is fixed, while inhomogeneities in the energy density may be present. Evidently, in general relativity, this is not very consistent. As a consequence, while equation (4.14) still describes the spectrum of the perturbations of any massless scalar field subdominant during inflation, e.g. a curvaton, see section 4.7, the perturbations of the inflaton behave differently.

The inflaton is assumed to dominate the energy density of the universe during inflation, hence any perturbation in the inflaton is reflected on the total energy momentum tensor, and, due to the Einstein's equations, on the metric as well. On the other hand, any perturbation in the metric generates a back-reaction on the inflaton field. To conclude, the perturbations in the metric and in the inflaton field must be necessarily studied together. A complete analysis of this problem can be found in the references quoted above. We only report here the final spectrum for the inflaton perturbations, that is:

$$\mathcal{P}_{inf} \simeq \frac{1}{2M_P^2 \epsilon_*} \left(\frac{H_*}{2\pi} \right)^2, \quad (4.15)$$

where the subscript $*$ means that the quantity is evaluated at Hubble crossing ($k = aH$). We also used the slow-roll parameter ϵ - see equations (4.2) - which takes into account the fact that the Hubble parameter H is not actually a constant, but slowly changes according to: $\dot{H} = -\epsilon H^2$

4.3 Non linear perturbations

As we have discussed in section 4.2, most probably primordial perturbations were generated in the very early universe, during inflation. But the earliest probe we have to study them is the CMB radiation, which represents the universe at much later times.

It is then necessary to study the evolution of the perturbations from their production to the beginning of the standard radiation dominated epoch, when the initial conditions for the "standard model" of the universe are set. In principle this is not a easy task,

since we do not know the details of the physical processes that happened in between, such as reheating, dark matter production, energy transfer from the inflaton and other eventual particles to radiation etc.

In spite of these uncertainties, we are able to make predictions because the wavelengths of the perturbations were outside the Hubble radius H^{-1} from before the end of inflation to recent times. As long as the perturbations are outside the Hubble radius, they can be parametrized by using some quantities that are conserved on large scales. These quantities allow us to study the evolution of perturbations from their origin to the CMB decoupling without taking into account the details of the physical processes which took place in the meanwhile. To this end we introduce below the curvature, isocurvature and number density perturbations.

Several definitions, which turn out to be equivalent on large scales, have been proposed for these quantities. In the following we adopt the fully non-linear and covariant approach introduced in [87; 88], and reviewed in [89]. For an alternative approach see [90].

The idea is to generalize in a geometric way the traditional quantities used to study linear perturbations, which are useful because conserved on large scales. The generalized quantities are covectors and it is possible to calculate their evolution equations in a fully non-linear and covariant form. Finally, these quantities can be expanded in a specific coordinate system to make quantitative calculations.

4.3.1 Curvature perturbation

We consider a perfect fluid characterized by the energy density ρ , the pressure P and the comoving four-velocity u^a , such that $u^a u_a = -1$. In the following we will always consider non-interacting fluids. Nevertheless it should be noted that this formalism can be extended to dissipative and interacting fluids [91]. The energy-momentum tensor associated with a perfect fluid is given by:

$$T_{ab} = (\rho + P) u_a u_b + P g_{ab}. \quad (4.16)$$

Let us define the expansion along the fluid world-lines and the integrated expansion as:

$$\Theta \equiv \nabla_a u^a, \quad \mathcal{N} \equiv \frac{1}{3} \int d\tau \Theta, \quad (4.17)$$

where τ is the proper time defined along the fluid world-lines. In a FLRW space-time the volume expansion Θ reduces to the Hubble parameter, $\Theta = 3H$. Hence, in the general case, $\Theta/3$ can be interpreted as the local Hubble parameter and $e^{\mathcal{N}}$ as a local scale factor. \mathcal{N} can be interpreted as the number of e-folds of the local scale factor

associated with an observer following the fluid.

The conservation of the energy-momentum tensor, $\nabla_a T^a_b = 0$, implies that the covector

$$\zeta_a \equiv \nabla_a \mathcal{N} - \frac{\dot{\mathcal{N}}}{\dot{\rho}} \nabla_a \rho \quad (4.18)$$

satisfies the relation

$$\dot{\zeta}_a \equiv \mathcal{L}_u \zeta_a = -\frac{\Theta}{3(\rho + p)} \Gamma_a, \quad \Gamma_a = \nabla_a p - \frac{\dot{p}}{\dot{\rho}} \nabla_a \rho, \quad (4.19)$$

where a dot denotes a Lie derivative along u^a , which is equivalent to an ordinary derivative for *scalar* quantities (e.g. $\dot{\rho} \equiv u^a \nabla_a \rho$), while for a covector:

$$\mathcal{L}_u \chi_a \equiv u^c \nabla_c \chi_a + \chi_c \nabla_a u^c. \quad (4.20)$$

The covector ζ_a can be defined for the global cosmological fluid or for any of the individual cosmological fluids, as we will discuss below.

The quantity Γ_a is a non-linear generalization of the non-adiabatic pressure. It vanishes for purely adiabatic perturbations, e.g. when P is solely a function of ρ or, more generally, when the adiabatic condition

$$\nabla_a p = \frac{\dot{p}}{\dot{\rho}} \nabla_a \rho \quad (4.21)$$

is satisfied.

Hence, equation (4.19) represents a conservation law for ζ_a . It is valid for any geometry and describes the evolution of the covector ζ in a exact and fully-nonperturbative way, valid at all scales. It should be noted that it directly derives from the conservation of the energy-momentum tensor and is independent of the underlying theory of gravitation.

Even though ζ_a and Γ_a in equations (4.18) and (4.19) are defined using covariant gradients, for all practical purposes they can be replaced by ordinary gradients. This is always true for combinations of the form $\nabla_a \chi - (\dot{\chi}/\dot{\eta}) \nabla_a \eta$ since for scalar quantities $\nabla_a \chi = \partial_a \chi + u_a \dot{\chi}$. Hence:

$$\zeta_a = \partial_a \mathcal{N} - \frac{\dot{\mathcal{N}}}{\dot{\rho}} \partial_a \rho, \quad \Gamma_a = \partial_a p - \frac{\dot{p}}{\dot{\rho}} \partial_a \rho. \quad (4.22)$$

Using the non-linear conservation equation

$$\dot{\rho} = -3\dot{\mathcal{N}}(\rho + P), \quad (4.23)$$

which follows from $u^b \nabla_a T_b^a = 0$, one can re-express ζ_a in the form

$$\zeta_a = \partial_a \mathcal{N} + \frac{\partial_a \rho}{3(\rho + P)}. \quad (4.24)$$

If $w \equiv P/\rho$ is constant, the above covector is a total gradient and can be written as

$$\zeta_a = \partial_a \left[\mathcal{N} + \frac{1}{3(1+w)} \ln \rho \right]. \quad (4.25)$$

On scales larger than the Hubble radius, the above definitions are equivalent to the non-linear curvature perturbation on uniform density hypersurfaces as defined in [92],

$$\zeta = \delta \mathcal{N} - \int_{\bar{\rho}}^{\rho} H \frac{d\tilde{\rho}}{\tilde{\rho}} = \delta \mathcal{N} + \frac{1}{3} \int_{\bar{\rho}}^{\rho} \frac{d\tilde{\rho}}{(1+w)\tilde{\rho}}, \quad (4.26)$$

where $H = \dot{a}/a$ is the Hubble parameter.

The procedure defined above can be applied to construct a covector associated to any quantity satisfying a local conservation law. This covector would then obey a fully non-linear conservation law valid at all scales. In the following we apply this procedure to some cases which are of interest for cosmology and high energy physics. In particular, we will consider as examples the conservation of energy and number densities for individual fluids.

4.3.2 Adiabatic, isocurvature and number perturbations

The initial conditions for the standard cosmological era are set at the BBN epoch, when the universe is radiation dominated and the cosmic plasma consists mainly of four species: photons, baryons (B), cold dark matter (CDM) and neutrinos (ν).

When several species are present it is useful to distinguish the non-linear curvature perturbation ζ of the total fluid from the individual non-linear perturbation ζ_A that describes the cosmological fluid A .

The curvature perturbation for a single non-interacting fluid A is defined as:

$$\zeta_A = \delta \mathcal{N} + \frac{1}{3(1+w_A)} \ln \left(\frac{\rho_A}{\bar{\rho}_A} \right), \quad (4.27)$$

where a bar denotes a homogeneous quantity and $w_A \equiv P_A/\rho_A = 0$ for a pressureless fluid or $w_A = 1/3$ for a relativistic fluid.

Inverting this relation yields the expression of the inhomogeneous energy density as

a function of the background energy density and of the curvature perturbation ζ_A ,

$$\rho_A = \bar{\rho}_A e^{3(1+w_A)(\zeta_A - \delta N)}, \quad (4.28)$$

which we will use many times in chapter 5.

In the presence of N fluids, the primordial perturbations can be decomposed into an *adiabatic* or *curvature* mode and $N - 1$ relative perturbations, or *isocurvature modes*¹. For the adiabatic mode, the curvature perturbation is the same for all the present fluids, independently of their equation of state:

$$\zeta_A = \zeta_B \quad (\text{adiabatic mode}), \quad (4.29)$$

while the non-linear isocurvature (or entropy) perturbation between two fluids A and B is defined as:

$$S_{A,B} \equiv 3(\zeta_A - \zeta_B) \quad (\text{isocurvature modes}). \quad (4.30)$$

In the following we will always define the isocurvature perturbations with respect to the radiation fluid, so that our definition for the isocurvature perturbation of the fluid A will be

$$S_A \equiv 3(\zeta_A - \zeta_r), \quad (4.31)$$

where ζ_r is the uniform-density curvature perturbation of the radiation fluid.

It should be noted that Equation (4.29) implies at the linear level and for adiabatic perturbations the relation among the energy density perturbations for radiation type (r) and matter type (m) fluids:

$$\frac{1}{4} \frac{\delta\rho_r}{\rho_r} = \frac{1}{3} \frac{\delta\rho_m}{\rho_m}. \quad (4.32)$$

Number density perturbations An other possible application of the general procedure introduced above concerns the particle number density n . In the contexts where it is conserved, n obeys the continuity equation $\nabla_a(n u^a) = 0$, which yields to the conservation law: $\dot{n} + \Theta n = 0$. By the spatial projection of this equation one can define the covector:

$$\zeta_a^{(n)} = \partial_a \mathcal{N} - \frac{\dot{\mathcal{N}}}{\dot{n}} \partial_a n. \quad (4.33)$$

This conserved covector can be used to study problems related to CDM or baryon asymmetry in the primordial universe.

¹To be more precise, there may be more than one isocurvature mode associated to a single species, see [93]. Nevertheless, we neglect this possibility in the remainder of this thesis.

4.4 From theory towards observations

The temperature anisotropies that we observe in the CMB sky were produced by several physical effects. For instance, some of them are due to events that happened in the recent universe, such as the scattering of light by intergalactic electrons in clusters of galaxies along the line of sight (Sunyaev-Zel'dovich effect [94]). An other example is our peculiar velocity with respect to the cosmic rest frame, which produces the so-called dipole anisotropy. Anisotropies arise also from intrinsic temperature and velocity fluctuations in plasma at last scattering surface (the latter is known as Doppler effect) and from the evolution of time-dependent perturbations from the last scattering surface to present (integrated Sachs-Wolfe effect [95]).

We are interested in the so called *primary* anisotropies, which were originated in the very early universe. In particular, fluctuations in the gravitational potential at last scattering surface induce an energy shift in the CMB photons, a phenomenon known as *Sachs-Wolfe effect* [95]. Together with the integrated Sachs-Wolfe effect, it gives the dominant contribution at large angular scales, $\theta > 1^\circ$, corresponding to low multipole index, $l < 40$. These scales were larger than the horizon at last scattering, hence they provide informations on the primordial perturbations produced during inflation.

In this section we analyze how the primordial perturbations affect temperature anisotropies. This topic can be found in several books, e.g. [84; 85] as well as in review papers, e.g. [86].

Let us consider the difference between the temperature observed in a direction \hat{n} and the present average temperature T_0 (in the following we will always omit the subscript 0):

$$\frac{\Delta T(\hat{n})}{T_0} \equiv \frac{T(\hat{n}) - T_0}{T_0}, \quad T_0 = \frac{1}{4\pi} \int d^2\hat{n} T(\hat{n}), \quad (4.34)$$

where a hat denotes a unit vector. It is convenient to expand temperature fluctuations in spherical harmonics $Y_{lm}(\hat{n})$:

$$a_{lm} \equiv \int d^2\hat{n} \frac{\Delta T(\hat{n})}{T} Y_{lm}^*(\hat{n}), \quad \frac{\Delta T(\hat{n})}{T} = \sum_{lm} a_{lm} Y_{lm}(\hat{n}), \quad (4.35)$$

where as usual l runs over all positive-definite integers and m over integers from $-l$ to l .

By expanding the temperature anisotropies in Fourier space and by using the Legendre expansion of the exponential, one finds:

$$\frac{\Delta T(\hat{n})}{T} = \int \frac{d^3k}{(2\pi)^3} \sum_l (i)^l (2l+1) g_l(k) \zeta_{\vec{k}} P_l(\hat{k} \cdot \hat{n}), \quad (4.36)$$

where $P_l(\hat{k} \cdot \hat{n})$ are the Legendre polynomials and $g_l(k)$ are the photon transfer functions. The equation written above was calculated for the case of one adiabatic perturbation $\zeta_{\vec{k}}$. The case with several perturbations is considered in Appendix B.

By substituting the expression above in the first of (4.35), one finds:

$$a_{lm} = 4\pi i^l \int \frac{d^3k}{(2\pi)^3} g_l(k) \zeta_{\vec{k}} Y_{lm}^*(\vec{k}). \quad (4.37)$$

The coefficients a_{lm} depend on the physical phenomena we have discussed at the beginning of this section as well as on the position of the observer in the universe. For this reason, cosmologically significant quantities must be averaged over the possible observer positions. The ergodic theorem assures that, under reasonable assumptions, the average over the observer positions and the averages over the historical accidents are the same. This is why in what follows we analyze the (lowest orders of the) correlation functions of the temperature anisotropies, which we denote as $\langle \dots \rangle$.

4.4.1 Power spectrum

If temperature anisotropies obey a Gaussian statistics, only the even correlation functions are non-vanishing and the all of them can be expressed in terms of the two-point correlation function. As a consequence, all the statistical properties of the temperature anisotropies can be extracted by a single function of multipole index l .

The rotational invariance of the universe requires that:

$$\langle a_{lm} a_{l'm'}^* \rangle = \delta_{ll'} \delta_{mm'} C_l, \quad (4.38)$$

where C_l are the multipole moments. It follows that the angular two-point correlation function is:

$$\left\langle \frac{\Delta T(\hat{n}_1)}{T} \frac{\Delta T(\hat{n}_2)}{T} \right\rangle = \sum_l \frac{2l+1}{4\pi} C_l P_l(\hat{n}_1 \cdot \hat{n}_2). \quad (4.39)$$

This is why C_l is also called the *temperature power spectrum*.

The coefficient C_l can be related to the spectrum of the primordial perturbations, by using equation (4.37). Let us consider the simple case of a single perturbation $\zeta_{\vec{k}}$, whose power spectrum P_ζ is defined from:

$$\langle \zeta_{\vec{k}_1} \zeta_{\vec{k}_2} \rangle = (2\pi)^3 \delta(\vec{k}_1 + \vec{k}_2) P_\zeta(k_1). \quad (4.40)$$

By using equations (4.38) and (4.37), one finds

$$C_l = \frac{2}{\pi} \int_0^\infty dk k^2 |g_l(k)|^2 P_\zeta(k). \quad (4.41)$$

In conclusion, in the Gaussian hypothesis, the two-point correlation functions C_l fully characterize the CMB sky. At the same time, the C_l are related to the spectra of the perturbations, as it is shown in (4.41). Hence, by measuring the present spectrum of the CMB anisotropies, we can extract informations on the spectrum of the primordial perturbations.

4.4.2 Bispectrum

If the perturbations are not fully Gaussian, this feature will appear, at lowest order, in the three-point correlation function, which is predicted to be vanishing in the Gaussian hypothesis.

The CMB angular bispectrum is defined as:

$$B_{l_1 l_2 l_3}^{m_1 m_2 m_3} \equiv \langle a_{l_1 m_1} a_{l_2 m_2} a_{l_3 m_3} \rangle, \quad (4.42)$$

where the triangle conditions and selection rules: $m_1 + m_2 + m_3 = 0$, $l_1 + l_2 + l_3 = \text{even}$, and $|l_i - l_j| \leq l_k \leq l_i + l_j$ for all permutations of indices must be satisfied.

Given the rotational invariance of the universe, $B_{l_1 l_2 l_3}^{m_1 m_2 m_3}$ can be written in the form [96; 97]

$$B_{l_1 l_2 l_3}^{m_1 m_2 m_3} = \mathcal{G}_{l_1 l_2 l_3}^{m_1 m_2 m_3} b_{l_1 l_2 l_3}, \quad (4.43)$$

where $b_{l_1 l_2 l_3}$ is the *reduced bispectrum* and

$$\mathcal{G}_{l_1 l_2 l_3}^{m_1 m_2 m_3} = \int d^2 \hat{n} Y_{l_1 m_1}(\hat{n}) Y_{l_2 m_2}(\hat{n}) Y_{l_3 m_3}(\hat{n}) \quad (4.44)$$

is the Gaunt integral. It is important to note that the reduced bispectrum contains all the physical informations on the angular bispectrum. Hence in what follows we will always refer to $b_{l_1 l_2 l_3}$.

Let us assume, as we did above, that there is only one curvature perturbation generated by the fluctuations of one Gaussian scalar field, ϕ , whose power spectrum is defined as:

$$\langle \phi(\vec{k}) \phi(\vec{k}') \rangle = (2\pi)^3 P_\phi(k) \delta(\vec{k} + \vec{k}'). \quad (4.45)$$

Up to second order we can write:

$$\zeta = N_1\phi + \frac{1}{2}N_2\phi^2 + \dots \quad (4.46)$$

By using equation (4.37) in the definitions (4.42) and (4.43) the reduced bispectrum can be calculated as [96; 97]:

$$b_{l_1 l_2 l_3} = 3N_2 N_1 N_1 \int_0^\infty r^2 dr \tilde{\beta}_{l_1}(r) \beta_{l_2}(r) \beta_{l_3}(r), \quad (4.47)$$

where $(l_1 l_2 l_3) \equiv [l_1 l_2 l_3 + 5 \text{ perms}]/3!$ and

$$\tilde{\beta}_l(r) \equiv \frac{2}{\pi} \int k^2 dk j_l(kr) g_l(k), \quad \beta_l(r) \equiv \frac{2}{\pi} \int k^2 dk j_l(kr) g_l(k) P_\phi(k). \quad (4.48)$$

The equations presented in this section can be easily generalized to include several independent observational quantities $X_{\vec{k}}^I$, such as $\zeta_{\vec{k}}$ and $S_{\vec{k}}$. The equations for the general case are presented in Appendix B.

4.5 Observational bounds on non-Adiabaticity

In a universe filled with photons, CDM, baryons and neutrinos we can decompose the primordial perturbations into four modes, see section 4.3.2. The power spectrum of the CMB anisotropies will then depend on the amplitude of the different modes as well as on their correlations, which are strongly model-dependent.

The adiabatic condition (4.29) is satisfied if all the fluids were in thermal equilibrium before the creation of any conserved and non-vanishing number, such as the baryon number, or when there is only one degree of freedom in the system, that means that all the cosmological fluids were created from the decay products of the same field, which also responsible for creating the primordial perturbations. As a consequence, detection of non-adiabaticity would imply that both the conditions written above were violated, hence there were multiple fields during inflation and some species remained out of thermal equilibrium with radiation for all the time or some conserved number was created before the era of thermal equilibrium.

Let us focus in particular on the case when non-adiabatic fluctuations between photons and dark matter are present. As combined adiabatic and isocurvature perturbations lead to a distortion of the acoustic peaks, which depends on their correlation [98], it is in principle possible to distinguish, in the observed fluctuations, the adiabatic and isocurvature contributions. Given the entropy perturbation S_c , the correlation is defined

as:

$$\mathcal{C}_{S,\zeta} = \frac{\mathcal{P}_{S,\zeta}}{\sqrt{\mathcal{P}_{S_c}\mathcal{P}_{\zeta_r}}}, \quad (4.49)$$

where the power spectrum of the non-adiabatic perturbation is given by:

$$\langle S_c(\vec{k})S_c(\vec{k}') \rangle = (2\pi)^3 \frac{2\pi^2}{k^3} \mathcal{P}_{S_c}(k) \delta(\vec{k} + \vec{k}')$$

and the power spectrum of the adiabatic perturbation \mathcal{P}_{ζ_r} and the hybrid one $\mathcal{P}_{S,\zeta}$ are straightforwardly defined. For instance, one good candidate for dark matter, the axion, may produce dark matter isocurvature perturbation independent of curvature perturbations, hence $\mathcal{C} = 0$ for this case. A different case of CDM isocurvature perturbation having $\mathcal{C} = 1$ can be produced by the curvaton decay, see section 4.7. Here and in the following we omit the subscripts S, ζ and write simply \mathcal{C} to indicate the correlation.

So far, there is no detection of any isocurvature component, but only an upper bound on the ratio between isocurvature and adiabatic power spectra, which, in our case, is given by

$$\alpha \equiv \frac{\mathcal{P}_{S_c}}{\mathcal{P}_{\zeta_r}}. \quad (4.50)$$

The observational constraints on α depend on the correlation. Writing $\alpha \equiv a/(1-a)$ (note that $\alpha \simeq a$ if α is small), the constraints (WMAP+BAO+SN) given in [45] are

$$a_0 < 0.064 \quad (95\%CL), \quad a_1 < 0.0037 \quad (95\%CL) \quad (4.51)$$

respectively for the uncorrelated case and for the fully correlated case ¹. When considering multi-field models, the present upper bound on the isocurvature contribution to the power spectrum provides a stringent constraint. In sections 5.2 and 5.3 of this thesis, this constraint is applied in the framework of the curvaton scenario [99] where large residual isocurvature perturbations (for CDM or baryons) can be generated, depending on how and when CDM or baryons are produced [100; 101] (see also [102; 103] for more detailed scenarios). The same constraints apply to moduli that are light during inflation, and thus acquire super-Hubble fluctuations, as discussed recently in [104].

Isocurvature modes introduce significant degeneracies with other cosmological parameters. As a consequence, the effects of isocurvature modes cannot be distinguished from the variations in the cosmological parameters yet. This result may be achieved by measures of the CMB polarization performed by the Planck satellite [105].

¹Our notations differ from those of [45]. Our a corresponds to their α and our fully *correlated* limit corresponds to their fully *anti-correlated* limit, because their definition of the correlation has the opposite sign.

4.6 Non-Gaussianities

As we have already said, the amount of non-Gaussianity in the CMB sky represents one of the crucial measures for differentiating models of the early universe [106; 107].

Perturbations generated by single slow-rolling inflaton field result in (almost) scale-invariant and adiabatic primordial fluctuations, which have negligible NG. On the other hand, several models produce non negligible non-Gaussian features which would be detectable in the three-point correlation function.

The degrees of non-Gaussianity are often represented by the so-called non-linearity parameters f_{NL} , which characterize the size of bispectrum of the curvature perturbation. The latter is defined as:

$$\langle \zeta_{\vec{k}_1} \zeta_{\vec{k}_2} \zeta_{\vec{k}_3} \rangle = (2\pi)^3 \delta(\Sigma_i \vec{k}_i) B(k_1, k_2, k_3). \quad (4.52)$$

Depending on the momentum distribution of the bispectrum or the shape of three point function, it is possible to identify different types of NG.

Several models produce a bispectrum of the form:

$$\begin{aligned} B^{(\text{local})}(k_1, k_2, k_3) &= \frac{6}{5} f_{NL}^{(\text{local})} [P_\zeta(k_1)P_\zeta(k_2) + 2 \text{ perms}] \\ &= \frac{6}{5} f_{NL}^{(\text{local})} A^2 \left[\frac{1}{k_1^{4-n_s} k_2^{4-n_s}} + 2 \text{ perms} \right], \end{aligned} \quad (4.53)$$

where we used the power spectrum of ζ , $P_\zeta(k) = A/k^{4-n_s}$, n_s is the power-law index of the primordial power spectrum¹ and A is a normalization factor. As it is clear from the expression above, $B^{(\text{local})}(k_1, k_2, k_3)$ has its maximum amplitude for the squeezed configuration $k_3 \ll k_2 \simeq k_1$.

This is called *local non-Gaussianity* because the characteristic shape of the bispectrum can arise from a curvature perturbation of the kind:

$$\zeta = \phi + (3/5) f_{NL}^{(\text{local})} \phi^2, \quad (4.54)$$

where both sides are evaluated at the same location in space and ϕ is a linear Gaussian fluctuation.

The present constraints on $f_{NL}^{(\text{local})}$, calculated from WMAP data by assuming purely adiabatic perturbations, are [45]:

$$-10 \leq f_{NL}^{(\text{local})} \leq 74. \quad (4.55)$$

¹ $n_s = 0.968 \pm 0.012$ at 68% C.L. [45]

Evidently, there is no detection of local NG so far. Nevertheless the bounds are centered on a value different from zero and it is possible that more precise observations, such as the ones performed by Planck [83], will detect some non-Gaussian feature in the CMB sky.

A curvature perturbation of the local kind (4.54) is realized in several models, see e.g. [108; 109] for recent reviews. Some possibilities are: multiple field inflation (during inflation or at the end of inflation: see e.g. [110]), modulated reheating [111; 112], curvaton (see section 4.7), modulated trapping [113], etc.

The parameter $f_{NL}^{(\text{local})}$ can be large in some of these models, while the amount of $f_{NL}^{(\text{local})}$ produced in single-field slow-roll inflation is much smaller than 1. In particular, in the squeezed limit $k_1 \rightarrow 0$, the simplest single-field slow-roll inflationary models with canonical kinetic term give [114]:

$$B^{(\text{local})}(k_1 \rightarrow 0, k_2, k_3) = (1 - n_s)P_\zeta(k_1)P_\zeta(k_3). \quad (4.56)$$

The local bispectrum has special significance because all the inflationary models predict the bispectrum in the form given in equation (4.56) irrespectively of the inflaton dynamics, as long as the inflaton is the only dynamical field [115]. Of course the previous statement is not valid when the curvature perturbation is partially or totally produced by fields other than the inflaton, such as the curvaton - see section 4.7. As a consequence, detecting a significant $f_{NL}^{(\text{local})}$ would rule out all the simplest single-field inflationary models.

It is interesting to combine the constraints on isocurvature modes and non-Gaussianity to explore the early Universe physics, as has been done recently in various scenarios [116; 117; 118; 119; 120; 121; 122; 123]. This is done in sections 5.2 and 5.3 of this thesis in the framework of the curvaton scenario.

Other types of NG can be generated by different physical mechanisms. For instance, inflationary models where scalar fields have non-canonical kinetic terms produce the so-called equilateral bispectrum, which has the maximum for the configuration $k_1 = k_2 = k_3$ [124]. An other possibility is the so-called orthogonal non-Gaussianity, which is approximately produced from a linear combination of higher-derivative scalar-field interaction terms [125].

4.7 The curvaton scenario

Usually models of high-energy physics beyond the standard one (e.g. SUSY theories) contain a large number of extra fields. Besides being motivated from particle physics, this kind of scenario is interesting from the cosmological point of view because extra fields

may contribute to the primordial curvature perturbations. This way the generation of the primordial perturbations can be disentangled from inflation, which therefore would be less constrained from the observations.

If such extra fields are displaced from the minima of their potentials by an amount of the order of the Planck scale, they may give rise to a period of extra-inflation. Otherwise, during inflation, they acquire random fluctuations of order $H_{inf}/2$. In the latter case, when the Hubble rate drops below their effective mass, they start to oscillate about the minima of their potentials and, if we average over several oscillations, they obey the equation of state of a massive pressure-less field. When they decay, they can generate primordial perturbations.

The energy density of a matter-like fluid decreases as a^{-3} , while for radiation it goes as a^{-4} . Hence, after the decay of the inflaton into radiation, matter-like fluids may end up dominating the energy density of the universe. They may eventually give relevant contributions to the primordial perturbations.

Late oscillating matter-like fields contributing to the curvature perturbation are usually called *curvatons* [99]. A recent review considering the particle theory origin of inflation and curvaton mechanisms for generating large scale structures and the observed temperature anisotropy in the cosmic microwave background radiation can be found in [126].

In the first version of the model, the curvature perturbation was solely generated by the curvaton, which was strictly dominating the energy of the universe at its decay epoch [99]. It should be noted that inflation is anyway necessary in this picture because it is the source of the quantum fluctuations of the curvaton, besides solving some issues of the standard cosmological model, such as the horizon and the flatness problems.

When the inflaton decays, a first radiation dominated era begins, which is followed by a second radiation era after the curvaton decays. It should be kept in mind that the energy content and the number of species present at the BBN epoch, that is at $T \leq 1\text{MeV}$, is strongly constrained. Hence, if any hypothetical field is present in the early universe, it should decay into ordinary radiation before BBN.

Let us dub the curvaton σ and its potential V . Being weakly coupled and light during inflation, the curvaton acquires perturbations with almost scale-invariant power spectrum $\mathcal{P} = (H/2\pi)^2$. The equation of motion for the unperturbed field reads:

$$\ddot{\sigma} + 3H\dot{\sigma} + V_{\sigma} = 0, \tag{4.57}$$

where the σ in subscript indicates a first derivative. The curvaton perturbation obeys the equation of motion:

$$\delta\ddot{\sigma} + 3H\delta\dot{\sigma} + V_{\sigma\sigma}\delta\sigma = 0, \tag{4.58}$$

where we have used the first order approximation $\delta(V_\sigma) \simeq V_{\sigma\sigma} \delta\sigma$.

Clearly, as long as $H \gg m$, the friction term dominates and the curvaton is effectively frozen. This regime is for instance realized during inflation, when the curvaton is subdominant and its effective mass is much smaller than the inflationary Hubble parameter. After the end of inflation, H decreases and the value $H \sim m$, when the curvaton starts oscillating, may be reached. Hence the curvaton behaves like matter having an isocurvature density perturbation, which is converted into a curvature perturbation when the curvaton decays.

The curvaton perturbation Before its decay, the oscillating curvaton (with mass $m \gg H$) is described by a pressureless, non-interacting fluid with energy density

$$\rho_\sigma = m^2 \sigma^2, \quad (4.59)$$

where σ is the rms amplitude of the curvaton field. As we have argued above, it may represent a significant fraction of the energy density of the universe or even dominate it.

The fractional field perturbation is then $\delta\sigma/\sigma = \delta\sigma_*/\sigma_*$, where the star denotes the epoch of horizon exit, and its spectrum is:

$$\mathcal{P}_{\delta\sigma/\sigma} = \left(\frac{H_*}{2\pi\sigma_*} \right)^2, \quad (4.60)$$

while the energy density perturbation is:

$$\frac{\delta\rho_\sigma}{\rho_\sigma} = 2 \frac{\delta\sigma_*}{\sigma_*} + \left(\frac{\delta\sigma_*}{\sigma_*} \right)^2. \quad (4.61)$$

On large scales and on unperturbed hypersurfaces the curvaton perturbation and its spectrum are given by - see section 4.3:

$$\zeta_\sigma = \frac{1}{3} \frac{\delta\rho_\sigma}{\rho_\sigma}, \quad \mathcal{P}_{\zeta_\sigma} = \left(\frac{H_*}{3\pi\sigma_*} \right)^2, \quad (4.62)$$

where the density perturbation is defined on the flat slicing of spacetime. When it decays into radiation, the curvaton converts its fluctuations into the curvature perturbations of the radiation fluid. If it decays only in photons and no CDM has been produced before the decay, no isocurvature mode survives.

Let us now relate the perturbation of the curvaton fluid with the fluctuations of the curvaton scalar field during inflation. Making use of equation (4.28), the inhomogeneous

energy density of the curvaton can be reexpressed as

$$\rho_\sigma = \bar{\rho}_\sigma e^{3(\zeta_\sigma - \delta N)}. \quad (4.63)$$

In the post-inflation era where the curvaton is still subdominant, the spatially flat hypersurfaces are characterized by $\delta N = \zeta_r$ (since CDM is also subdominant). On such a hypersurface, the curvaton energy density can be written as

$$\bar{\rho}_\sigma e^{3(\zeta_\sigma - \zeta_r)} = \bar{\rho}_\sigma e^{S_\sigma} = m^2 (\bar{\sigma} + \delta\sigma)^2, \quad (4.64)$$

where we used the energy density (4.59).

Expanding this expression up to second order, and using the conservation of $\delta\sigma/\sigma$ in a quadratic potential, we obtain

$$S_\sigma = 2\frac{\delta\sigma_*}{\bar{\sigma}_*} - \left(\frac{\delta\sigma_*}{\bar{\sigma}_*}\right)^2, \quad (4.65)$$

where the initial curvaton field perturbation, $\delta\sigma_*$, is assumed to be Gaussian, as would be expected for a weakly coupled field. The curvaton entropy perturbation (4.65) thus contains a linear part \hat{S} which is Gaussian and a second order part which is quadratic in \hat{S} :

$$S_\sigma = \hat{S} - \frac{1}{4}\hat{S}^2, \quad \text{with} \quad \hat{S} \equiv 2\frac{\delta\sigma_*}{\bar{\sigma}_*} \quad (4.66)$$

where the power spectrum of \hat{S} , generated during inflation, is given by

$$\langle \hat{S}(\vec{k}) \hat{S}(\vec{k}') \rangle = (2\pi)^3 \frac{2\pi^2}{k^3} \mathcal{P}_{\hat{S}}(k) \delta(\vec{k} + \vec{k}'), \quad \mathcal{P}_{\hat{S}}(k) = \frac{4}{\sigma_*^2} \left(\frac{H_*}{2\pi}\right)^2. \quad (4.67)$$

The subscript $*$ means that the quantity is evaluated at the time when the corresponding scale crossed out the Hubble radius during inflation.

Beyond the simplest model The basic curvaton mechanism can be enriched in several ways. For instance, it is possible to generate isocurvature perturbations from the curvaton decay, e.g. in the baryon or CDM components [101]. In the latter case, the power spectrum should satisfy the bound (4.51), that is, it should be dominated by the adiabatic component¹.

An other interesting possibility is a hybrid model, where both the inflaton and the curvaton generate non-negligible perturbations [127]. If the inflaton decay generated a perturbation of the radiation fluid, indicated by ζ_{inf} , the total curvature perturbations

¹When the curvature perturbation is fully generated by the curvaton, the perturbations are fully correlated, $\mathcal{C}_{S,\zeta} = 1$.

is given by [100]:

$$\zeta = \frac{4\rho_r\zeta_{inf} + 3\rho_\sigma\zeta_\sigma}{4\rho_r + 3\rho_\sigma} = r_\sigma\zeta_\sigma + (1 - r_\sigma)\zeta_{inf} \quad r_\sigma = \frac{3\rho_\sigma}{4\rho_r + 3\rho_\sigma}, \quad (4.68)$$

where the energy densities are calculated at the decay of the curvaton.

If the curvature perturbation is mostly generated by the curvaton, that means that ζ_{inf} is negligible, it follows that:

$$\zeta = \frac{\rho_\sigma}{4\rho_r + 3\rho_\sigma} \frac{\delta\rho_\sigma}{\rho_\sigma} = \frac{r_\sigma}{3} \frac{\delta\rho_\sigma}{\rho_\sigma}. \quad (4.69)$$

If the curvaton energy density dominates over radiation, then $\zeta = (1/3)\delta\rho_\sigma/\rho_\sigma$. In the most general case the power spectrum of the primordial curvature perturbation is given by

$$\mathcal{P}_\zeta = \mathcal{P}_{\zeta_{inf}} + r_\sigma^2\mathcal{P}_{\zeta_\sigma} = (1 + \lambda)\mathcal{P}_{\zeta_{inf}},$$

where $\mathcal{P}_{\zeta_{inf}}$ is the spectrum of the perturbation generated by the inflaton decay and λ is the ratio between the curvaton and inflaton contributions.

One can also consider models with several curvatons [128], which are well motivated from particle physics, as stated at the beginning of this section. The CDM isocurvature generation in models with one or two curvatons was discussed in [129].

Chapter 5

Evolution of perturbations

This chapter of the thesis is mostly based on [129]. In section 5.1 a unified treatment of linear and nonlinear perturbations is presented. Such a treatment enables to compute the evolution of perturbations through one or several cosmological transitions, such as the decay of some particle species. The various decay products and their branching ratio are taken into account. This formalism can thus be applied to a large class of early Universe scenarios, in order to compute automatically their predictions for adiabatic and isocurvature perturbations, and their non-Gaussianities. As input, one simply needs parameters that depend on the homogeneous evolution. This thus provides a simple way to confront an early Universe scenario, and its underlying particle physics model, with the present and future cosmological data. The explicit expressions for perturbations are given up to the second order.

As applications of the proposed general formalism, two specific examples are considered. The first example, presented in section 5.2, is a more refined treatment of the isocurvature perturbations and their non-Gaussianity in the mixed curvaton-inflation scenario [127; 130; 131]. The second example, presented in section 5.3, deals with a multiple-curvaton scenario [128; 132; 133; 134]. In both examples, the results that have been obtained in previous works are generalized, since the curvaton is allowed to decay into several species.

The extension of the presented formalism up to the third order can be found in [135]. There the general expressions for the perturbations at the third order are presented and the calculation of the trispectrum for the two examples considered in this thesis is performed.

5.1 Decay

Let us consider a cosmological transition associated with the decay of some species of particles, which we will call σ .

In the sudden decay approximation, the decay takes place on the hypersurface characterized by the condition

$$H_d = \Gamma_\sigma. \quad (5.1)$$

Therefore, since H depends only on the *total* energy density, the decay hypersurface is a hypersurface of uniform total energy density, with $\delta N_d = \zeta$, where ζ is the global curvature perturbation. Using (4.28), the equality between the total energy densities, respectively before and after the decay, thus reads

$$\sum_A \bar{\rho}_{A-} e^{3(1+w_A)(\zeta_{A-}-\zeta)} = \bar{\rho}_{\text{decay}} = \sum_B \bar{\rho}_{B+} e^{3(1+w_B)(\zeta_{B+}-\zeta)}, \quad (5.2)$$

where the subscripts $-$ and $+$ label quantities defined, respectively, *before* and *after* the transition.

5.1.1 Before the decay

The first equality in (5.2) leads to

$$\sum_A \Omega_A e^{3(1+w_A)(\zeta_{A-}-\zeta)} = 1, \quad (5.3)$$

where we have defined $\Omega_A \equiv \bar{\rho}_{A-}/\bar{\rho}_{\text{decay}}$ (to avoid confusion, the Ω_A are always defined just *before* the decay). The above relation determines ζ as a function of the ζ_{A-} .

At linear order, this gives

$$\zeta = \frac{1}{\bar{\Omega}} \sum_A \tilde{\Omega}_A \zeta_{A-} \quad (\text{first order}) \quad (5.4)$$

with the notation

$$\tilde{\Omega}_A \equiv (1+w_A)\Omega_A, \quad \tilde{\Omega} \equiv \sum_A \tilde{\Omega}_A. \quad (5.5)$$

Expanding (5.3) up to second order, one finds

$$\zeta = \frac{1}{\bar{\Omega}} \sum_A \tilde{\Omega}_A \left[\zeta_{A-} + \frac{3}{2}(1+w_A)(\zeta_{A-}-\zeta)^2 \right] \quad (\text{second order}) \quad (5.6)$$

where, on the right hand side, ζ is to be replaced by its first order expression (5.4).

5.1.2 After the decay

We now consider the outcome of the decay. In general, the species σ decays into various species A , with respective decay widths $\Gamma_{A\sigma}$. Defining the relative branching ratios

$$\gamma_{A\sigma} \equiv \frac{\Gamma_{A\sigma}}{\Gamma_\sigma}, \quad \Gamma_\sigma \equiv \sum_A \Gamma_{A\sigma}, \quad (5.7)$$

one can write the energy density of the fluid A after the decay in terms of the energy densities of A and of σ before the decay as

$$\rho_{A+} = \rho_{A-} + \gamma_{A\sigma} \rho_{\sigma-}. \quad (5.8)$$

Using (4.28), one can rewrite this nonlinear equation in terms of the curvature perturbations ζ_{A+} , ζ_{A-} and $\zeta_{\sigma-}$, which yields

$$e^{3(1+w_A)(\zeta_{A+}-\zeta)} = \frac{\bar{\rho}_{A-} e^{3(1+w_A)(\zeta_{A-}-\zeta)} + \gamma_{A\sigma} \bar{\rho}_{\sigma-} e^{3(1+w_\sigma)(\zeta_{\sigma-}-\zeta)}}{\bar{\rho}_{A-} + \gamma_{A\sigma} \bar{\rho}_{\sigma-}}. \quad (5.9)$$

This expression thus gives ζ_{A+} as a function of ζ_{A-} , ζ_σ and of the global ζ . Substituting ζ in terms of all the ζ_{B-} , one finally obtains ζ_{A+} as a function of all the ζ_{B-} .

Following this procedure, one finds that the linear curvature perturbation for any given fluid A is given by

$$\zeta_{A+} = \sum_B T_A^B \zeta_{B-} \quad (\text{first order}) \quad (5.10)$$

with

$$T_A^A = 1 - f_A + f_A \frac{(w_A - w_\sigma) \tilde{\Omega}_A}{(1 + w_A) \tilde{\Omega}} \quad (5.11)$$

$$T_A^\sigma = f_A \frac{1 + w_\sigma}{1 + w_A} + f_A \frac{(w_A - w_\sigma) \tilde{\Omega}_\sigma}{(1 + w_A) \tilde{\Omega}} \quad (5.12)$$

$$T_A^C = f_A \frac{(w_A - w_\sigma) \tilde{\Omega}_C}{(1 + w_A) \tilde{\Omega}}, \quad C \neq A, \sigma. \quad (5.13)$$

In the above expressions, we have introduced the parameter

$$f_A \equiv \frac{\gamma_{A\sigma} \Omega_\sigma}{\Omega_A + \gamma_{A\sigma} \Omega_\sigma}, \quad (5.14)$$

which represents the fraction of the fluid A that has been created by the decay. If A does not belong to the decay products of σ , then $f_A = 0$. The opposite limit, $f_A = 1$, occurs when all the fluid A is produced by the decay. For the intermediate values of f_A ,

part of A is produced by the decay while the other part is preexistent.

In the following, we will assume that the decaying species behaves like non-relativistic matter (this is the case for a curvaton or modulus field that oscillates in a quadratic potential) and we will thus always use $w_\sigma = 0$.

From the above expressions (5.11-5.13), it is straightforward to check that

$$\sum_B T_A^B = 1. \quad (5.15)$$

The post-decay perturbation ζ_{A+} can thus be seen as the barycenter of the pre-decay perturbations ζ_{B-} with the weights T_A^B (all these coefficients satisfy $0 \leq T_A^B \leq 1$ for $w_\sigma = 0$). Note that if the fluid A is not produced in the decay (i.e. $f_A = 0$), then the transfer coefficients are trivial: $T_A^B = \delta_A^B$.

Since it is convenient to use the same range of species indices *before and after* the transition, we also introduce the coefficients $T_\sigma^B = 0$, which imply that $\zeta_{\sigma+} = 0$. This convention will be especially useful when one needs to combine several transitions, as we will discuss soon.

At second order, expanding (5.9) and substituting the first order expression (5.4) for ζ , one obtains

$$\zeta_{A+} = \sum_B T_A^B \zeta_{B-} + \sum_{B,C} U_A^{BC} \zeta_{B-} \zeta_{C-}, \quad (\text{second order}) \quad (5.16)$$

with

$$U_A^{BC} \equiv \frac{3}{2} \left[T_{AB}(1 + w_B) \delta_{BC} + 2 \frac{\tilde{\Omega}_C}{\tilde{\Omega}} (w_A - w_B) T_{AB} - (1 + w_A) T_{AB} T_{AC} - \frac{\tilde{\Omega}_B \tilde{\Omega}_C}{\tilde{\Omega}^2} \left(1 + w_A - \sum_D T_{AD}(1 + w_D) \right) \right]. \quad (5.17)$$

The change of the various isocurvature perturbations, defined in (4.31), can also be determined by using the above expressions. In particular, at linear order, one finds, using the property (5.15), the simple expression

$$S_{A+} = \sum_B (T_A^B - T_r^B) S_{B-} \quad (\text{first order}). \quad (5.18)$$

5.1.3 Several transitions

If the early Universe scenario involves several cosmological transitions, for example several particle decays, one can use the above expressions successively to determine the final ‘‘primordial’’ perturbations, i.e. the initial conditions at the onset of the standard

cosmological era.

For linear perturbations, the expression of the final perturbations as a function of the initial ones, is simply given by

$$\zeta_A^{(f)} = \sum_B T_A^B \zeta_B^{(i)}, \quad T = \prod_k T_{[k]} \quad (5.19)$$

where T is the matricial product of all transfer matrices $T_{[k]}$, which describe the successive transitions.

The cosmological transitions can result from the decay of some particle species but they can be of other types. For example, if CDM consists of WIMPs (Weakly Interacting Massive Particles), the freeze-out can be treated as a cosmological transition. If radiation is the dominant species at freeze-out, then $\zeta_{c+} = \zeta_r$. But, if other species are significant in the energy budget of the universe at the time of freeze-out, any entropy perturbation between the extra species and radiation will modify the above relation. The presence of a pressureless component, like a curvaton, leads to [101]

$$\zeta_{c+} = \zeta_{r-} + \frac{(\alpha_f - 3)\Omega_\sigma}{2(\alpha_f - 2) + \Omega_\sigma} (\zeta_{\sigma-} - \zeta_{r-}), \quad \alpha_f \equiv \frac{m_c}{T_f} + \frac{3}{2} \quad (5.20)$$

at linear order, while the other ζ_A remain unchanged. The symbol “ σ ” denotes here the conglomerate of all pressureless matter at the time of freeze-out, except of course the CDM species that is freezing out.

5.2 Scenario with a single curvaton

Let us now apply our formalism to a simple scenario with only three initial species: radiation (r), CDM (c) and a curvaton (σ), considered in e.g. [136]. After the decay of the curvaton, the radiation and CDM perturbations remain unchanged and provide the initial conditions for the perturbations at the onset of the standard cosmological phase (let us say around $T \sim 1$ MeV).

5.2.1 Perturbations after the decay

Linear order According to the expressions (5.11-5.13), the linear transfer matrix T_{AB} is given in this case by

$$T = \begin{pmatrix} 1 - x_r & x_c & x_r - x_c \\ 0 & 1 - f_c & f_c \\ 0 & 0 & 0 \end{pmatrix}, \quad x_r \equiv \frac{f_r}{\tilde{\Omega}}, \quad x_c \equiv \frac{1}{4}\Omega_c x_r \quad (5.21)$$

where the order of the species is (r, c, σ) . This means that the linear curvature perturbations for radiation and for CDM, after the curvaton decay, are given respectively by

$$\zeta_{r+} = (1 - x_r) \zeta_{r-} + x_c \zeta_{c-} + (x_r - x_c) \zeta_{\sigma-} \quad (5.22)$$

and

$$\zeta_{c+} = (1 - f_c) \zeta_{c-} + f_c \zeta_{\sigma-}. \quad (5.23)$$

The entropy perturbation after the decay is thus

$$\frac{1}{3} S_{c+} \equiv \zeta_{c+} - \zeta_{r+} = (1 - f_c - x_c) \zeta_{c-} + (x_r - 1) \zeta_{r-} + (f_c + x_c - x_r) \zeta_{\sigma-}, \quad (5.24)$$

which can also be expressed directly in terms of the pre-decay entropy perturbations, following (5.18),

$$S_{c+} = (1 - f_c - x_c) S_{c-} + (f_c + x_c - x_r) S_{\sigma-}. \quad (5.25)$$

Note that, if many CDM particles are created by the decay of the curvaton, a significant fraction of them could annihilate, leading to an effective suppression of the final isocurvature perturbation. This effect has been studied in [102] and can easily be incorporated in our formalism.

In practice, we will need the above expressions only in the limit $x_c = 0$ since Ω_c is usually negligible when the decay occurs. The coefficient x_r , which we will shorten into r from now on, can then be expressed as

$$r \equiv x_r = \frac{f_r}{\Omega_\sigma} \left(\frac{3\Omega_\sigma}{4 - \Omega_\sigma} \right) \equiv \xi \tilde{r}. \quad (5.26)$$

The first factor,

$$\xi \equiv \frac{f_r}{\Omega_\sigma} = \frac{\gamma_{r\sigma}}{1 - (1 - \gamma_{r\sigma})\Omega_\sigma} \quad (5.27)$$

can be interpreted as the transfer efficiency between the curvaton and radiation. Its maximal value, $\xi = 1$, is reached when all the energy stored in the curvaton is converted into radiation, i.e. when $\gamma_{r\sigma} = 1$, as usually assumed in most works on the curvaton. However, if a fraction of the curvaton energy goes into species other than radiation, then the transfer efficiency ξ is reduced. The second factor,

$$\tilde{r} \equiv \frac{3\Omega_\sigma}{4 - \Omega_\sigma}, \quad (5.28)$$

is the familiar coefficient that appears in the literature on the curvaton, which coincides with our r only if $\xi = 1$.

Second order The expressions for the curvature perturbations up to second order are obtained from the general expression (5.16-5.17), using the transfer matrix (5.21). The expression for CDM is relatively simple:

$$\zeta_{c+} = (1 - f_c)\zeta_{c-} + f_c\zeta_{\sigma-} + \frac{3}{2}f_c(1 - f_c)(\zeta_{c-} - \zeta_{\sigma-})^2. \quad (5.29)$$

The expression for radiation is much more complicated in general, but in the limit $x_c = 0$, which is of interest to us, the radiation perturbation reduces to

$$\zeta_{r+} = \zeta_{r-} + \frac{r}{3}S_{\sigma-} + \frac{r}{18}\left[3 - 4r + \frac{2r}{\xi} - \frac{r^2}{\xi^2}\right]S_{\sigma-}^2. \quad (5.30)$$

In the limit $\gamma_{r\sigma} = 1$, i.e. $\xi = 1$, one recovers the usual expression.

Note that, although Ω_c is assumed to be very small, it cannot be neglected in the expression for f_c [see (5.14)] because $\gamma_{c\sigma}$ or Ω_σ can be very small, and f_c can thus take any value between 0 and 1.

5.2.2 Primordial adiabatic and isocurvature perturbations

For simplicity, we now assume that the post-inflation perturbations for dark matter and radiation, i.e. before the curvaton decay, are the same and depend only on the inflaton fluctuations,

$$\zeta_{c-} = \zeta_{r-} = \zeta_{\text{inf}}, \quad (5.31)$$

so that there are only two independent degrees of freedom from the inflationary epoch, ζ_{inf} and \hat{S} .

Substituting (4.66) and (5.31) into (5.30) and (5.29) yields

$$\zeta_r = \zeta_{\text{inf}} + \frac{r}{3}\hat{S} + \frac{r}{36}\left[3 - 8r + \frac{4r}{\xi} - 2\frac{r^2}{\xi^2}\right]\hat{S}^2 \quad (5.32)$$

and

$$S_c = (f_c - r)\hat{S} + \frac{1}{12}\left[3f_c(1 - 2f_c) - r\left(3 - 8r + \frac{4r}{\xi} - 2\frac{r^2}{\xi^2}\right)\right]\hat{S}^2, \quad (5.33)$$

where \hat{S} is the Gaussian perturbation produced by the curvaton. In the limit $\gamma_{r\sigma} = 1$, i.e. $\xi = 1$, one recovers the well-known expression for ζ_r .

Considering only the linear part of (5.32), one finds that the power spectrum for the primordial adiabatic perturbation ζ_r can be expressed as

$$\mathcal{P}_{\zeta_r} = \mathcal{P}_{\zeta_{\text{inf}}} + \frac{r^2}{9}\mathcal{P}_{\hat{S}} \equiv (1 + \lambda)\mathcal{P}_{\zeta_{\text{inf}}} \equiv \Xi^{-1}\frac{r^2}{9}\mathcal{P}_{\hat{S}} \quad (5.34)$$

where λ is defined as the ratio between the curvaton and inflaton contributions and $\Xi = (1 + \lambda^{-1})^{-1}$ as the ratio between the curvaton contribution and the total curvature power spectrum. The limit $\lambda \gg 1$, or $\Xi \simeq 1$, corresponds to the standard curvaton scenario, where the inflaton perturbation is ignored. The cases where the inflaton contribution is not negligible correspond to the mixed inflaton-curvaton scenario [127]. The curvaton contribution is subdominant when $\lambda \ll 1$, i.e. $\Xi \ll 1$.

Let us now turn to the primordial isocurvature perturbation. As can be read from the linear part of (5.33), its power spectrum is given by

$$\mathcal{P}_{S_c} = (f_c - r)^2 \mathcal{P}_{\hat{S}}. \quad (5.35)$$

and the correlation between adiabatic and isocurvature fluctuations is

$$\mathcal{C} \equiv \frac{\mathcal{P}_{S_c, \zeta_r}}{\sqrt{\mathcal{P}_{S_c} \mathcal{P}_{\zeta_r}}} = \varepsilon_f \Xi^{1/2}, \quad \varepsilon_f \equiv \text{sgn}(f_c - r). \quad (5.36)$$

In the pure curvaton limit ($\Xi \simeq 1$), adiabatic and isocurvature perturbations are either fully correlated, if $\varepsilon_f > 0$, or fully anti-correlated, if $\varepsilon_f < 0$. In the opposite limit ($\Xi \ll 1$), the correlation vanishes. For intermediate values of Ξ , the correlation is only partial, as can be also obtained in multifield inflation [137].

The ratio between isocurvature and adiabatic power spectra, in our case, is given by

$$\alpha \equiv \frac{\mathcal{P}_{S_c}}{\mathcal{P}_{\zeta_r}} = 9 \left(1 - \frac{f_c}{r}\right)^2 \Xi. \quad (5.37)$$

As we have seen in section 4.5, the observational constraints on α depend on the correlation. Anyway, the observational constraint $\alpha \ll 1$ can be satisfied in only two cases:

- $|f_c - r| \ll r$, i.e. a fine-tuning between the two parameters f_c and r . This includes the case $f_c = 1$ with $r \simeq 1$, considered in [116].
- $\Xi \ll 1$, i.e. the curvaton contribution to the observed power spectrum is very small.

5.2.3 Non-Gaussianities

Let us now examine the amplitude of the non-Gaussianities that can be generated in our model. We recall that our observable quantities ζ and S are of the form

$$\zeta = \zeta_{\text{inf}} + z_1 \hat{S} + \frac{1}{2} z_2 \hat{S}^2, \quad S = s_1 \hat{S} + \frac{1}{2} s_2 \hat{S}^2, \quad (5.38)$$

where ζ_{inf} and \hat{S} are two independent Gaussian fields and where the coefficients can be read explicitly from (5.32) and (5.33).

Applying the general results of Appendix B to the present situation, we can easily compute for our model the “reduced” angular bispectrum, which is of direct interest for a comparison with CMB observations and which generalizes the analysis of [96] in the purely adiabatic case. Specializing (B.14) to our case, one finds

$$b_{l_1 l_2 l_3} = 3 \sum_{I,J,K} b_{NL}^{I,JK} \int_0^\infty r^2 dr \tilde{\beta}_{l_1}^I(r) \beta_{l_2}^J(r) \beta_{l_3}^K(r) \quad (5.39)$$

with

$$b_{NL}^{I,JK} \equiv N_{(2)}^I N_{(1)}^J N_{(1)}^K, \quad (5.40)$$

where $N_{(2)}^\zeta = z_2$, $N_{(2)}^S = s_2$, $N_{(1)}^\zeta = z_1$, $N_{(1)}^S = s_1$, respectively, and

$$\tilde{\beta}_l^I(r) \equiv \frac{2}{\pi} \int k^2 dk j_l(kr) g_l^I(k), \quad \beta_l^I(r) \equiv \frac{2}{\pi} \int k^2 dk j_l(kr) g_l^I(k) P_{\hat{S}}(k), \quad (5.41)$$

where the $g_l^I(k)$ denote the adiabatic ($I = \zeta$) and isocurvature ($I = S$) transfer functions. Because of the symmetry under exchange of the last two indices, the reduced bispectrum contains six different contributions, whose amplitude is parametrized by the six coefficients $b_{NL}^{I,JK}$.

In order to compare these coefficients with the usual parameter f_{NL} defined in the purely adiabatic case - see section 4.6, one must recall that f_{NL} is proportional to the bispectrum of ζ divided by the square of its power spectrum. By noting that the $\beta_l^I(r)$ introduced in (5.41) involve $P_{\hat{S}}$, this implies that the analogs of f_{NL} can be defined by dividing the coefficient $b_{NL}^{I,JK}$ by the square of the ratio $P_\zeta/P_{\hat{S}} = z_1^2 \Xi^{-1}$. We thus introduce the parameters

$$\tilde{f}_{NL}^{I,JK} \equiv \frac{6}{5} f_{NL}^{I,JK} \equiv \frac{\Xi^2}{z_1^4} b_{NL}^{I,JK}, \quad (5.42)$$

explicitly given by the expressions

$$\tilde{f}_{NL}^{\zeta,\zeta\zeta} = \frac{z_2}{z_1^2} \Xi^2, \quad \tilde{f}_{NL}^{\zeta,\zeta S} = \frac{s_1 z_2}{z_1^3} \Xi^2, \quad \tilde{f}_{NL}^{\zeta,SS} = \frac{s_1^2 z_2}{z_1^4} \Xi^2, \quad (5.43)$$

$$\tilde{f}_{NL}^{S,\zeta\zeta} = \frac{s_2}{z_1^2} \Xi^2, \quad \tilde{f}_{NL}^{S,\zeta S} = \frac{s_1 s_2}{z_1^3} \Xi^2, \quad \tilde{f}_{NL}^{S,SS} = \frac{s_1^2 s_2}{z_1^4} \Xi^2. \quad (5.44)$$

In the absence of isocurvature perturbations, the above non-linear parameters vanish

except the first one, yielding

$$f_{NL}^{\zeta,\zeta\zeta} = \frac{5}{6} \left(\frac{3}{2r} + \frac{2}{\xi} - 4 - \frac{r}{\xi^2} \right) \Xi^2, \quad (5.45)$$

which exactly coincides with the familiar parameter f_{NL} . The amplitude of the non-Gaussianities is determined by the three parameters r , ξ and Ξ (note that one recovers the usual prediction of the pure curvaton scenario for $\xi = 1$ and $\Xi = 1$), which take values between 0 and 1. A sufficiently small r , or even ξ , leads to a significant non-Gaussianity from the adiabatic component, whereas a small Ξ tends to suppress it.

If isocurvature modes are present, however, the five other terms in the reduced bispectrum (5.39) will also contribute in general. Interestingly, the six functions on the right hand side of (5.39) have distinct dependences on the l_i , because they involve different combinations of the adiabatic and isocurvature transfer functions. Therefore, this allows in principle to measure, or constrain, independently the corresponding six non-linear parameters from the CMB data. The precise determination of constraints on the $f_{NL}^{I,JK}$ is beyond the scope of the present work, but since all the functions multiplying the $b_{NL}^{I,JK}$ in (5.39) are of similar amplitude, one can a priori expect the constraints on the $f_{NL}^{I,JK}$ to be of the same order of magnitude as those on f_{NL}^1 .

Let us now explore the amplitude of the non-linear parameters in our model. First of all, let us stress that finding significant non-Gaussianities (typically $f_{NL} \sim 10 - 100$) requires, in all cases, a small denominator z_1 , i.e. $r \ll 1$, which will thus be assumed below. Second, it is worth noting that all the coefficients are related via the two rules

$$f_{NL}^{I,JS} = \frac{s_1}{z_1} f_{NL}^{I,J\zeta} \quad (R1), \quad f_{NL}^{S,IJ} = \frac{s_2}{z_2} f_{NL}^{\zeta,IJ}, \quad (R2). \quad (5.46)$$

Therefore, the hierarchy between the parameters can be deduced from the value of the first order ratio

$$\frac{s_1}{z_1} = 3 \left(\frac{f_c}{r} - 1 \right) = \varepsilon_f \sqrt{\frac{\alpha}{\Xi}}, \quad \varepsilon_f \equiv \text{sgn}(f_c - r), \quad (5.47)$$

where we have used (5.37), as well as the second order ratio s_2/z_2 , which is a more complicated expression in general.

We now consider successively the two limits for which the isocurvature bound is satisfied.

¹Observational constraints on isocurvature non-Gaussianities are given in [117], for an isocurvature perturbation of the form $S = S_L + f_{NL}^{(iso)} S_L^2$, where S_L is Gaussian. Their non-linear parameter $f_{NL}^{(iso)}$ is related to ours according to $\tilde{f}_{NL}^{S,SS} = 2f_{NL}^{(iso)} \alpha^2$, $\tilde{f}_{NL}^{S,\zeta S} = 2f_{NL}^{(iso)} \alpha^{3/2} |\mathcal{C}|$ and $\tilde{f}_{NL}^{S,\zeta\zeta} = 2f_{NL}^{(iso)} \alpha \mathcal{C}^2$, where \mathcal{C} is the correlation defined in (5.36).

Limit $|f_c - r| \ll r$, with $\Xi \simeq 1$ (**pure curvaton scenario**) In this case, as long as $f_c > r$, the isocurvature-adiabatic ratio α must satisfy the observational constraint $\alpha \simeq a_1 \leq 0.0037$, since we are in the fully correlated case. The relevant ratios are given here by

$$\frac{s_1}{z_1} \simeq \varepsilon_f \sqrt{\alpha}, \quad \frac{s_2}{z_2} \simeq \frac{\varepsilon_f \sqrt{\alpha} - 2\tilde{r}(2 - \tilde{r})}{1 + 2\tilde{r}(2 - \tilde{r})/3} \quad (5.48)$$

where we have taken the limit $r = \xi \tilde{r} \ll 1$ (although r cannot be smaller than 10^{-2} , to be compatible with observational constraint on f_{NL}). If r is small because $\tilde{r} \ll 1$, then the denominator in the expression for s_2/z_2 reduces to 1. However, if $\xi \ll 1$ while \tilde{r} is of order 1, the full expression for s_2/z_2 is needed.

The value of the first ratio implies that, with respect to $f_{NL}^{\zeta, \zeta \zeta}$, the coefficients $f_{NL}^{\zeta, \zeta S}$ and $f_{NL}^{\zeta, SS}$ are suppressed with factors $\sqrt{\alpha}$ and α , respectively, according to (R1). Analogously the coefficients $f_{NL}^{S, \zeta S}$ and $f_{NL}^{S, SS}$ are suppressed, respectively with factors $\sqrt{\alpha}$ and α , with respect to $f_{NL}^{S, \zeta \zeta}$. By contrast, using (R2), one sees that $f_{NL}^{S, \zeta \zeta}$ could be of the same order of magnitude as $f_{NL}^{\zeta, \zeta \zeta}$, if $\tilde{r} \sim 1$, or suppressed if \tilde{r} is small.

To conclude, in the pure curvaton scenario, it is possible to satisfy the isocurvature constraint and to get measurable non-Gaussianities only by assuming a fine-tuning between f_c and r at the percent level. In this situation, only the purely adiabatic parameter is significant, while the other parameters are suppressed, with increasing powers of α .

Limit $\Xi \ll 1$ In this limit α must satisfy the constraint $\alpha \simeq a_0 < 0.064$ (uncorrelated case).

In the regime $f_c \ll r \ll 1$, one finds that both ratios s_1/z_1 and s_2/z_2 reduce to (-3), independently of the value of \tilde{r} . Therefore, the relation between the non-linear parameters is simply

$$\tilde{f}_{NL}^{\zeta, \zeta \zeta} \simeq \frac{\alpha^2}{54r}, \quad \tilde{f}_{NL}^{I, JK} \simeq (-3)^{I_S} \tilde{f}_{NL}^{\zeta, \zeta \zeta} \quad (f_c \ll r \ll 1) \quad (5.49)$$

where I_S is the number of S among the indices (I, JK) . This is the result obtained in [116] for $f_c = 0$. For α close to its present upper bound, one sees that detectable non-Gaussianity can be generated with $r \sim 10^{-5}$.

By contrast, in the regime $f_c \gg r$, the purely adiabatic coefficient is strongly suppressed since

$$\tilde{f}_{NL}^{\zeta, \zeta \zeta} \simeq \frac{\alpha^2 r^3}{54 f_c^4}. \quad (5.50)$$

However, the other coefficients are now enhanced with respect to the purely adiabatic

coefficient, via the large factors

$$\frac{s_1}{z_1} \simeq 3 \frac{f_c}{r}, \quad \frac{s_2}{z_2} \simeq 3 \frac{f_c}{r} (1 - 2f_c). \quad (5.51)$$

where, for simplicity, we have assumed $\tilde{r} \ll 1$ (the other possibility $\xi \ll 1$ yields a more complicated expression for the second ratio, with a dependence on \tilde{r}). The dominant term is therefore the purely isocurvature term

$$\tilde{f}_{NL}^{S,SS} \simeq \alpha^2 \frac{1 - 2f_c}{2f_c} \quad (5.52)$$

If $f_c \sim 1$, this purely isocurvature non-Gaussianity, although enhanced with respect to all the other contributions, remains negligible since it is suppressed by the very small factor α^2 . This was the conclusion reached in [116] (for $f_c = 1$).

However, we now see that this suppression can be compensated if f_c is smaller than α^2 . The purely isocurvature parameter and the other ones are then given by

$$\tilde{f}_{NL}^{S,SS} \simeq \frac{\alpha^2}{2f_c}, \quad \tilde{f}_{NL}^{I,JK} \simeq \left(\frac{r}{3f_c} \right)^{I_\zeta} \tilde{f}_{NL}^{S,SS} \quad (r \ll f_c \ll 1) \quad (5.53)$$

where I_ζ is the number of ζ among the three indices. One can notice that the amplitude of the purely isocurvature non-Gaussianity does not depend on the parameter r , but only on α and f_c . For instance, with $\alpha = 0.05$ which satisfies the current observational bound, a value $f_c = 10^{-5}$ yields $\tilde{f}_{NL}^{S,SS} \sim 100$. In such a scenario, one gets observable non-Gaussianity that comes essentially from isocurvature modes, even if the latter are subdominant in the power spectrum.

5.3 Scenario with two curvatons

We now apply our formalism to the models where two curvatons are present in the early Universe (see e.g. [128; 132; 133]). The curvaton σ will be assumed to decay first, followed later by the curvaton denoted χ .

5.3.1 First order

At linear order, the decay of the first curvaton can be characterized by the transfer matrix

$$T_{[1]} = \begin{pmatrix} 1 - x_{r1} & x_{c1} & x_{\chi 1} & x_{r1} - x_{c1} - x_{\chi 1} \\ 0 & 1 - f_{c1} & 0 & f_{c1} \\ 0 & 0 & 1 - f_{\chi 1} & f_{\chi 1} \\ 0 & 0 & 0 & 0 \end{pmatrix}, \quad (5.54)$$

where the order of the species is (r, c, χ, σ) , while the decay of the second curvaton is characterized by the transfer matrix

$$T_{[2]} = \begin{pmatrix} 1 - x_{r2} & x_{c2} & x_{r2} - x_{c2} & 0 \\ 0 & 1 - f_{c2} & f_{c2} & 0 \\ 0 & 0 & 0 & 0 \\ 0 & 0 & 0 & 0 \end{pmatrix}. \quad (5.55)$$

In the above matrices, the definitions of the parameters are analogous to the definitions introduced in (5.21), i.e. $x_{r1} \equiv f_{r1}/\tilde{\Omega}_1$, $x_{c1} \equiv \Omega_{c1} x_{r1}/4$, $x_{\chi1} \equiv \Omega_{\chi1} x_{r1}/4$, etc, and the indices 1 and 2 refer respectively to the first and second decays. We have also allowed the possibility that the first curvaton σ decays into the second curvaton χ , hence the presence of the parameter $f_{\chi1}$.

The expression of the perturbations for radiation and CDM, after the two transitions, are expressed in terms of the initial perturbations ζ_{B0} via the product of the two transfer matrices given above, i.e.

$$\zeta_A = \sum_B (T_{[2]} \cdot T_{[1]})_A^B \zeta_{B0}. \quad (5.56)$$

At first order, the radiation curvature perturbation, after the second curvaton decay, reads

$$\zeta_r = \zeta_{r0} + z_\sigma S_{\sigma0} + z_\chi S_{\chi0} + z_c S_{c0}, \quad (5.57)$$

with

$$3z_\sigma = (1 - x_{r2})(x_{r1} - x_{c1} - x_{\chi1}) + f_{c1}x_{c2} + f_{\chi1}(x_{r2} - x_{c2}), \quad (5.58)$$

$$3z_\chi = (1 - f_{\chi1})(x_{r2} - x_{c2}) + (1 - x_{r2})x_{\chi1}, \quad (5.59)$$

$$3z_c = (1 - f_{c1})x_{c2} + (1 - x_{r2})x_{c1}. \quad (5.60)$$

Combining this expression with that of the CDM curvature perturbation, according to (4.31), we find that the CDM entropy perturbation is given by

$$S_c = s_\sigma S_{\sigma0} + s_\chi S_{\chi0} + s_c S_{c0}, \quad (5.61)$$

with

$$s_\sigma = -3z_\sigma + f_{c1}(1 - f_{c2}) + f_{c2}f_{\chi1}, \quad (5.62)$$

$$s_\chi = -3z_\chi + f_{c2}(1 - f_{\chi1}), \quad (5.63)$$

$$s_c = -3z_c + (1 - f_{c1})(1 - f_{c2}). \quad (5.64)$$

For simplicity, we will restrict ourselves, from now on, to the case where $S_{c0} = 0$.

Defining Λ as the ratio between the two curvaton power spectra, such that

$$P_{S_{\chi 0}} \equiv \Lambda P_{S_{\sigma 0}}, \quad (5.65)$$

one easily finds that the ratio between the isocurvature and the adiabatic spectra is given by

$$\alpha = \frac{P_{S_c}}{P_{\zeta_r}} = \frac{s_\sigma^2 + \Lambda s_\chi^2}{z_\sigma^2 + \Lambda z_\chi^2} \Xi, \quad \Xi \equiv \frac{\lambda_\chi + \lambda_\sigma}{1 + \lambda_\chi + \lambda_\sigma} \quad (5.66)$$

where λ_χ and λ_σ are defined as in (5.34), i.e.

$$\mathcal{P}_{\zeta_r} = \mathcal{P}_{\zeta_{r0}} + z_\sigma^2 \mathcal{P}_{S_{\sigma 0}} + z_\chi^2 \mathcal{P}_{S_{\chi 0}} \equiv (1 + \lambda_\sigma + \lambda_\chi) \mathcal{P}_{\zeta_{r0}}. \quad (5.67)$$

The correlation between ζ_r and S_c can be expressed as

$$\mathfrak{c} = \frac{z_\sigma s_\sigma + \Lambda z_\chi s_\chi}{\sqrt{(s_\sigma^2 + \Lambda s_\chi^2)(z_\sigma^2 + \Lambda z_\chi^2)}} \sqrt{\Xi}. \quad (5.68)$$

The observational constraints on α impose that at least one of the following conditions must be satisfied:

$$\Xi \ll 1 \quad \text{or} \quad s_\sigma^2 + \Lambda s_\chi^2 \ll z_\sigma^2 + \Lambda z_\chi^2. \quad (5.69)$$

The first possibility, $\Xi \ll 1$, corresponds to a power spectrum dominated by the inflaton, whereas the second possibility requires special cancellations in (5.62-5.63) so that s_σ and s_χ are suppressed.

5.3.2 Second order

We now consider the perturbations up to the second order, in order to compute the non-Gaussianities. First, let us decompose the curvaton entropy perturbations as in (4.66), so that

$$S_{\sigma 0} = \hat{S}_\sigma - \frac{1}{4} \hat{S}_\sigma^2, \quad S_{\chi 0} = \hat{S}_\chi - \frac{1}{4} \hat{S}_\chi^2, \quad (5.70)$$

where \hat{S}_σ and \hat{S}_χ are two independent Gaussian quantities.

The radiation curvature perturbation and the dark matter entropy perturbation after the second decay, up to second order, are given in our notation by

$$\zeta_r = \zeta_{r0} + z_\sigma \hat{S}_\sigma + z_\chi \hat{S}_\chi + z_{\sigma\chi} \hat{S}_\sigma \hat{S}_\chi + \frac{1}{2} z_{\sigma\sigma} \hat{S}_\sigma^2 + \frac{1}{2} z_{\chi\chi} \hat{S}_\chi^2 \quad (5.71)$$

$$S_c = s_\sigma \hat{S}_\sigma + s_\chi \hat{S}_\chi + s_{\sigma\chi} \hat{S}_\sigma \hat{S}_\chi + \frac{1}{2} s_{\sigma\sigma} \hat{S}_\sigma^2 + \frac{1}{2} s_{\chi\chi} \hat{S}_\chi^2 \quad (5.72)$$

where the coefficients z_σ , z_χ , s_σ and s_χ have already been defined in (5.58-5.59) and (5.62-5.63), respectively. The expressions for the second order coefficients are given in Appendix C.

Let us calculate the reduced bispectrum by using the general expression given in the Appendix. In our model, ignoring the inflaton which does not produce significant non-Gaussianities, the relevant power spectra are independent so that

$$P^{ab}(k) = \begin{pmatrix} 1 & 0 \\ 0 & \Lambda \end{pmatrix} P_{\hat{S}_\sigma}, \quad (5.73)$$

where we furthermore assume that Λ is strictly independent of k (this is indeed the case if the masses of both curvatons are negligible with respect to H during inflation).

As a consequence, the reduced bispectrum can be reduced to the same expression as that already given in equation (5.39) with

$$\beta_l^I(r) \equiv \frac{2}{\pi} \int k^2 dk j_l(kr) g_l^I(k) P_{\hat{S}_\sigma}(k) \quad (5.74)$$

and the six parameters

$$b_{NL}^{I,JK} \equiv N_{\sigma\sigma}^I N_\sigma^J N_\sigma^K + \Lambda N_{\sigma\chi}^I (N_\sigma^J N_\chi^K + N_\chi^J N_\sigma^K) + \Lambda^2 N_{\chi\chi}^I N_\chi^J N_\chi^K, \quad (5.75)$$

where the coefficients N_{ab}^I , which are defined as in (B.1), can be read off directly from (5.71) and (5.72). In complete analogy with the model with one curvaton, to be compared with the standard f_{NL} , these coefficients must be divided by the square of the ratio $P_\zeta/P_{S_{\sigma 0}} = (z_\sigma^2 + \Lambda z_\chi^2)/\Xi$, hence:

$$\tilde{f}_{NL}^{I,JK} \equiv \left(\frac{\Xi}{z_\sigma^2 + \Lambda z_\chi^2} \right)^2 b_{NL}^{I,JK}. \quad (5.76)$$

The six non-linearity coefficients are thus given by

$$\begin{aligned} \tilde{f}_{NL}^{\zeta,\zeta\zeta} &= \left(\frac{\Xi}{z_\sigma^2 + \Lambda z_\chi^2} \right)^2 [z_{\sigma\sigma} z_\sigma^2 + 2\Lambda z_{\sigma\chi} z_\sigma z_\chi + \Lambda^2 z_{\chi\chi} z_\chi^2], \\ \tilde{f}_{NL}^{\zeta,\zeta S} &= \left(\frac{\Xi}{z_\sigma^2 + \Lambda z_\chi^2} \right)^2 [z_{\sigma\sigma} z_\sigma s_\sigma + \Lambda z_{\sigma\chi} (z_\sigma s_\chi + z_\chi s_\sigma) + \Lambda^2 z_{\chi\chi} z_\chi s_\chi], \\ \tilde{f}_{NL}^{\zeta,SS} &= \left(\frac{\Xi}{z_\sigma^2 + \Lambda z_\chi^2} \right)^2 [z_{\sigma\sigma} s_\sigma^2 + 2\Lambda z_{\sigma\chi} s_\sigma s_\chi + \Lambda^2 z_{\chi\chi} s_\chi^2], \end{aligned}$$

$$\begin{aligned}
 \tilde{f}_{NL}^{S,\zeta\zeta} &= \left(\frac{\Xi}{z_\sigma^2 + \Lambda z_\chi^2} \right)^2 [s_{\sigma\sigma} z_\sigma^2 + 2\Lambda s_{\sigma\chi} z_\sigma z_\chi + \Lambda^2 s_{\chi\chi} z_\chi^2], \\
 \tilde{f}_{NL}^{S,S\zeta} &= \left(\frac{\Xi}{z_\sigma^2 + \Lambda z_\chi^2} \right)^2 [s_{\sigma\sigma} z_\sigma s_\sigma + \Lambda s_{\sigma\chi} (s_\sigma z_\chi + s_\chi z_\sigma) + \Lambda^2 s_{\chi\chi} s_\chi z_\chi], \\
 \tilde{f}_{NL}^{S,SS} &= \left(\frac{\Xi}{z_\sigma^2 + \Lambda z_\chi^2} \right)^2 [s_{\sigma\sigma} s_\sigma^2 + 2\Lambda s_{\sigma\chi} s_\sigma s_\chi + \Lambda^2 s_{\chi\chi} s_\chi^2].
 \end{aligned} \tag{5.77}$$

In the following we analyze explicitly some limiting cases in order to explore the parameter space. The goal is to see whether it is possible to obtain significant non-Gaussianities while satisfying the bound on the isocurvature spectrum.

5.3.3 Limit $\Lambda \ll 1$

Let us first mention that we have checked that our results agree with those of [128] in the limit where the curvatons decay only into radiation (i.e. $f_{c1} = f_{c2} = f_{\chi 1} = 0$), the dark matter abundance is neglected (i.e. $x_{c1} = x_{c2} = 0$) and the inflaton contribution is ignored (i.e. $\Xi = 1$).

In this limit where the contributions from the second curvaton are negligible, one finds

$$\alpha \simeq \Xi \frac{s_\sigma^2}{z_\sigma^2}, \quad \tilde{f}_{NL}^{\zeta\zeta\zeta} \simeq \Xi^2 \frac{z_{\sigma\sigma}}{z_\sigma^2}, \tag{5.78}$$

while the other five non-linear coefficients can be deduced from $\tilde{f}_{NL}^{\zeta\zeta\zeta}$ according to the relations

$$f_{NL}^{I,JS} \simeq \frac{s_\sigma}{z_\sigma} f_{NL}^{I,J\zeta} \quad f_{NL}^{S,IJ} \simeq \frac{s_{\sigma\sigma}}{z_{\sigma\sigma}} f_{NL}^{\zeta,IJ}. \tag{5.79}$$

The quantity α is constrained by observations to be small, which requires either $\Xi \ll 1$ or $|s_\sigma| \ll |z_\sigma|$.

First possibility: $\Xi \ll 1$, while $|z_\sigma| \sim |s_\sigma|$.

This leads to a suppression of all the non-Gaussianity coefficients by a factor Ξ^2 . However, the coefficients $\tilde{f}_{NL}^{\zeta,JK}$ can still be significant if the ratio $z_{\sigma\sigma}/z_\sigma^2$ can compensate the Ξ^2 suppression (similarly for the $f_{NL}^{S,JK}$ if $s_{\sigma\sigma}/z_\sigma^2$ compensates the Ξ^2 suppression).

Let us consider a specific example, with the simplifying assumptions

$$x_{c1} = x_{c2} = f_{\chi 1} = x_{\chi 1} = 0, \tag{5.80}$$

that is, we neglect the energy fraction of dark matter and assume that the curvaton σ does not decay into χ and that χ is subdominant when σ decays. Under these assumptions, $z_\sigma = x_{r1}(1 - x_{r2})/3$ and we further assume $f_{c1} \ll z_\sigma$ so that $s_\sigma \simeq -3z_\sigma$.

In the two limits $x_{r1} = \tilde{r}_1 \xi_1 \ll 1$ and $(1 - x_{r2}) \ll 1$, z_σ is small and the adiabatic non-Gaussianity behaves as

$$\tilde{f}_{NL}^{\zeta, \zeta \zeta} = \frac{1}{1 - x_{r2}} \left[\tilde{f}_{NL1}^{\zeta, \zeta \zeta} + \frac{x_{r2}}{1 - x_{r2}} \left(\frac{3}{2} + x_{r2} \tilde{f}_{NL2}^{\zeta, \zeta \zeta} \right) \right], \quad (5.81)$$

where $\tilde{f}_{NL1,2}^{\zeta, \zeta \zeta}$ correspond to single-curvaton coefficient, equation (5.45), but calculated with the parameters $\xi_{1,2}$ and $x_{r1,r2}$ respectively.

If we assume $x_{r2} \ll 1$, the above equation corresponds to the single-curvaton result (5.49). The other coefficients also follow the relations given in (5.49), since $s_{\sigma\sigma}/z_{\sigma\sigma} = -3$ with the assumptions (5.80) and $f_{c1} \ll 1$, and are thus of comparable magnitude.

Second possibility: $|s_\sigma| \ll |z_\sigma|$

When a small α is the consequence of $|s_\sigma| \ll |z_\sigma|$, one sees from the first relation in (5.79) that all the $f_{NL}^{I,JS}$ are strongly suppressed with respect to $f_{NL}^{I,J\zeta}$. However, the two coefficients $f_{NL}^{I,\zeta\zeta}$ can still be important if $|z_\sigma|$ is sufficiently small. By examining (5.58) and (5.62), one sees that getting $|s_\sigma| \ll |z_\sigma| \ll 1$ requires some fine-tuning between the coefficients, which we now discuss.

In order to get $|z_\sigma| \ll 1$, the first possibility is that the first curvaton is subdominant, i.e. $x_{r1} = \mathcal{O}(\epsilon)$, where ϵ is some small number (we neglect x_{c2} which must be small because we are deep in the radiation era), which then requires either $x_{r2} = \mathcal{O}(\epsilon)$ or $f_{\chi1} = \mathcal{O}(\epsilon)$. The second possibility is that the second curvaton dominates at decay, i.e. $x_{r2} = 1 - \mathcal{O}(\epsilon)$, which also requires that $f_{\chi1} = \mathcal{O}(\epsilon)$. Then, to obtain $|s_\sigma| \ll |z_\sigma|$, the terms of the right hand side of (5.62), which are of order ϵ must compensate each other so that their sum is at most of order $\mathcal{O}(\alpha\epsilon)$, which necessitates some special relation between the f_A and the x_A .

If we consider again the assumptions (5.80) and neglect f_{c2} , one finds that the fine-tuning condition to get $|s_\sigma| \ll |z_\sigma|$ is

$$f_{c1} - x_{r1}(1 - x_{r2}) \leq \mathcal{O}(\alpha\epsilon). \quad (5.82)$$

The adiabatic parameter $\tilde{f}_{NL}^{\zeta, \zeta \zeta}$ is given in equation (5.81), with now $\Xi \sim 1$, and its value is of order 10 when $\epsilon \sim x_{r1}(1 - x_{r2}) \sim 0.1$. Since $s_{\sigma\sigma}/z_{\sigma\sigma} \simeq -3 + \mathcal{O}(f_{c1}/x_{r1}(1 - x_{r2}))$, we also have $\tilde{f}_{NL}^{S, \zeta \zeta} \sim \tilde{f}_{NL}^{\zeta, \zeta \zeta}$.

Note that a significant non-Gaussianity generated by a dominant curvaton ($x_{r2} = 1 - \mathcal{O}(\epsilon)$) has already been pointed out in [128], but we see here that satisfying the isocurvature bound requires additional constraints on the branching ratios of the curvatons.

5.3.4 Other limits

Limit $\Lambda \gg 1$ In this limit, one obtains

$$\alpha \sim \Xi \frac{s_\chi^2}{z_\chi^2}, \quad \tilde{f}_{NL}^{\zeta\zeta\zeta} \sim \Xi^2 \frac{z_{\chi\chi}}{z_\chi^2}, \quad f_{NL}^{I,JS} \simeq \frac{s_\chi}{z_\chi} f_{NL}^{I,J\zeta}, \quad f_{NL}^{S,IJ} \simeq \frac{s_{\chi\chi}}{z_{\chi\chi}} f_{NL}^{\zeta,IJ}. \quad (5.83)$$

By comparing with (5.78) and (5.79), one sees that the analysis is analogous to the previous case, by replacing z_σ , $z_{\sigma\sigma}$, s_σ and $s_{\sigma\sigma}$ by z_χ , $z_{\chi\chi}$, s_χ and $s_{\chi\chi}$, respectively.

When the curvaton contribution to the power spectrum is not negligible, significant non-Gaussianity, while satisfying the isocurvature bound, is obtained when $|s_\chi| \ll |z_\chi| \ll 1$. This constraint is satisfied if one assumes $f_{\chi 1} = 1 - \mathcal{O}(\epsilon)$, which means that the second curvaton is created mainly by the decay of the first, while $x_{r2} = 1 - \mathcal{O}(\epsilon)$, $x_{\chi 1} \lesssim \mathcal{O}(\epsilon)$ and $f_{c2} = 1 - \mathcal{O}(\epsilon)$. Other possibilities exist but require some fine-tuning between the parameters, in analogy with the previous analysis in the case $\Lambda \ll 1$.

Intermediate values of Λ In this case, one must satisfy simultaneously the constraints $|s_\sigma| \ll |z_\sigma|$ and $|s_\chi| \ll |z_\chi|$, due to the isocurvature bound. The relative strength of the different \tilde{f}_{NL} coefficients cannot be expressed in such a simple form as in (5.79), but it will be determined again by the ratios s_σ/z_σ , s_χ/z_χ , $s_{\sigma\sigma}/z_{\sigma\sigma}$ and $s_{\chi\chi}/z_{\chi\chi}$.

In order to get also a significant non-Gaussianity, we look for parameter values such that

$$z_\sigma, z_\chi \sim \mathcal{O}(\epsilon), \quad s_\sigma, s_\chi \lesssim \mathcal{O}(\alpha \epsilon). \quad (5.84)$$

These constraints can be satisfied by fine-tuning the parameters. Solving $s_\sigma \simeq 0$ and $s_\chi \simeq 0$ for the two parameters f_{c1} and f_{c2} yields

$$f_{c1} \simeq \frac{(x_{r1} - x_{c1})(1 - f_{\chi 1}) - x_{\chi 1}}{1 - f_{\chi 1} - x_{\chi 1}}, \quad f_{c2} \simeq x_{r2} - x_{c2} + \frac{1 - x_{r2}}{1 - f_{\chi 1}} x_{\chi 1}. \quad (5.85)$$

The observational constraint on the isocurvature power spectrum is satisfied if these two fine-tuning relations hold simultaneously, at the level $\mathcal{O}(\alpha \epsilon)$. Using these relations, one finds interesting non-Gaussianity for the following set of parameters: $x_{r1} = \mathcal{O}(\epsilon)$, $x_{r2} = \mathcal{O}(\epsilon)$, $x_{\chi 1} = \mathcal{O}(\alpha \epsilon)$, $f_{c1} = x_{r1} - x_{c1} + \mathcal{O}(\alpha \epsilon)$, $f_{c2} = x_{r2} + \mathcal{O}(\alpha \epsilon)$, with negligible values for x_{c2} . In this scenario, both curvatons are subdominant at their decay and the fraction of produced dark matter is fine-tuned.

5.4 Discussion of the results

In this chapter of the thesis we have introduced a systematic treatment in order to compute the evolution of linear and non-linear cosmological perturbations in a cosmo-

logical transition due to the decay of some particle species. Our main results can be summarized as follows.

At the linear level, the evolution of all individual curvature perturbations can be expressed in terms of a transfer matrix, whose coefficients depend on background quantities, such as the relative abundances of the fluids at the decay, their equation of state parameters and the relative decay branching ratios [see Eqs (5.10-5.14)]. At the non-linear level, the post-decay curvature perturbations can also be given in terms of the pre-decay perturbations quite generally, and we have presented explicitly these relations at second order [see Eqs (5.16-5.17)]. We have then applied our general formalism to two specific examples.

The first example is the mixed curvaton-inflaton scenario in which we allow the dark matter to be created both before *and* during the curvaton decay. We find, in particular, the remarkable result that it is possible to obtain *isocurvature dominated* non-Gaussianities with, as required by the CMB measurements, an adiabatic dominated power spectrum.

In the second example, we have studied scenarios with several curvaton-like fields and obtained results that generalize previous works on two-curvaton scenarios by taking into account the various decay products of the curvatons. We have explored the parameter space to see whether it is possible to find significant non-Gaussianity while satisfying the isocurvature bound in the power spectrum. We have found that several such regions exist, but often at the price of a fine-tuning between the parameters.

In the presence of isocurvature modes, which can be correlated with the adiabatic modes, non-Gaussianity of the local type is much richer than in the purely adiabatic case and we have shown that the angular bispectrum is the sum of six different contributions. As a consequence, in addition to the traditional f_{NL} (adiabatic) parameter, we have identified five new non-linear parameters that must be taken into account: one purely isocurvature parameter and four correlated parameters. We have computed these parameters in the two models we have investigated.

Beyond the two examples considered in this thesis, this formalism can be used as a general toolbox to study systematically the cosmological constraints, arising from linear perturbations and from non-Gaussianities, for particle physics models and their associated cosmological scenarios.

Conclusions

In spite of the great progresses made in its understanding, the early universe is a source of unsolved and fascinating problems. In many cases, the road to comprehension requires putting together informations and ideas from cosmology and particle physics.

In this thesis two problems of cosmo-particle physics are considered. The first deals with the possibility that W bosons formed a special quantum state of matter, the Bose-Einstein condensate, in the early universe. Such a system could be realized near the electro-weak (EW) phase transition epoch in the presence of a large lepton asymmetry. The interactions of the spins of the condensed W bosons were studied in the EW sector of the standard model of particle physics, finding that it is energetically favorable for them to be aligned. In this sense, a ferromagnetic state could be formed in the early universe, leading to the spontaneous macroscopic magnetization of the primordial plasma.

Nevertheless, since the universe was hot and dense, screening phenomena, acting on the magnetic interactions, may change this behavior. Because of the screening effects, the system may be turned into an antiferromagnetic one, where it is energetically favored for the spins to be anti-aligned. In the standard QED without condensates, it is known that the magnetic interactions are not screened, while the electric ones decay exponentially faster than in vacuum with the distance (Debye screening). Nevertheless, medium effects in the presence of a Bose-Einstein condensate have started to be considered only very recently.

To analyze them, it is necessary to calculate the photon polarization operator in the medium, that is done in this thesis for a $U(1)$ gauge theory (QED) with scalar condensate. A perturbative technique was used, which is physically transparent and at the same time safe in abelian theories with massive particles. It is found that, in the presence of a condensate, infrared singular terms arise in the photon polarization operator. As a consequence, the screened electrostatic potential shows quite striking behavior. Namely, it decays parametrically faster than in the absence of the condensate, it is not analytic in the coupling constant e , at finite temperature it has a power-law decreasing contribution and the leading term at large distance oscillates.

The second topic considered in this thesis is the study of primordial perturbations and the calculation of experimentally observable quantities. A general formalism is presented, which enables the computation of linear and non-linear perturbations through the cosmic evolution, focusing in particular on the decay of some particle species. The evolution is parametrized in terms of evolution matrices whose coefficients depend only on the homogeneous background parameters. Two specific examples of cosmological

interest are presented as applications, namely models in which the perturbations are produced from combined contributions of several fluids, the inflaton plus one or two curvatons. The isocurvature perturbation in the dark matter component, produced from the decay of the curvaton(s) or before, has been considered as well. The parameter space has been explored to find the regions where relevant non-Gaussianities can be produced while satisfying the stringent bound on the isocurvature modes.

The work presented in this thesis has several interesting developments.

Concerning the first part, the proposed mechanism of spontaneous magnetization can be used in connection to the long standing cosmological problem of generation of galactic and intergalactic magnetic fields. It would be interesting to proceed further to check whether it can generate realistic patterns of primordial magnetic fields at large scales.

Another open issue concerns the impact of the condensate on the interactions. In this thesis an abelian theory, electrodynamics, has been considered. Nevertheless, the impact of the condensate on non-abelian gauge theories is still unknown. It would be interesting to study such effects in the non-abelian case, such as the EW group before the symmetry breaking. Such a problem is of cosmological interest, since it is thought that the EW symmetry was restored in the early universe. In such a case, the W condensation would be easier, since it could be induced by lower values of the lepton asymmetry with respect to the broken phase.

Finally, concerning the primordial perturbations, the formalism which has been developed can be applied to a wide range of models to calculate the impact on them of the cosmic transitions. In particular, the proposed evolution matrices are valid for any adiabatic equation of state and several subsequent transitions can be easily taken into account by iteration. As a consequence, this formalism can be naturally used to calculate the evolution of the perturbations from their production to the last scattering surface. This kind of problem can be studied in many models of physics beyond the standard one, which typically involve several extra particle species.

Appendix A

Equations of motion for the SM gauge bosons

Cubic and quartic couplings of gauge bosons are present in the lagrangian of the Standard Model. Explicitly, these terms take the form:

$$\begin{aligned} L_3 = & ie \cot \theta_W \left[W^{\mu\nu} W_\mu^\dagger Z_\nu - (W^{\mu\nu})^\dagger W_\mu Z_\nu + W_\mu W_\nu^\dagger Z^{\mu\nu} \right] \\ & + ie \left[W^{\mu\nu} W_\mu^\dagger A_\nu - (W^{\mu\nu})^\dagger W_\mu A_\nu + W_\mu W_\nu^\dagger F^{\mu\nu} \right] \end{aligned} \quad (\text{A.1})$$

and

$$\begin{aligned} L_4 = & -\frac{e^2}{2 \sin^2 \theta_W} \left[(W_\mu^\dagger W^\mu)^2 - W_\mu^\dagger W^{\mu\dagger} W_\nu W^\nu \right] \\ & - e^2 \cot^2 \theta_W \left[W_\mu^\dagger W^\mu Z_\nu Z^\nu - W_\mu^\dagger Z^\mu W_\nu Z^\nu \right] \\ & - e^2 \cot \theta_W \left[2W_\mu^\dagger W^\mu Z_\nu A^\nu - W_\mu^\dagger Z^\mu W_\nu A^\nu - W_\mu^\dagger A^\mu W_\nu Z^\nu \right] \\ & - e^2 \left[W_\mu^\dagger W^\mu A_\nu A^\nu - W_\mu^\dagger A^\mu W_\nu A^\nu \right]. \end{aligned} \quad (\text{A.2})$$

where we have used $V_{\mu\nu} \equiv \partial_\mu V_\nu - \partial_\nu V_\mu$ for the vectors $V_\mu = W_\mu, Z_\mu$, while A_μ is the electromagnetic potential and $F_{\mu\nu} = \partial_\mu A_\nu - \partial_\nu A_\mu$ is the Maxwell tensor. To avoid confusion it is worth noting that the field strength $G^{\mu\nu}$ defined after equation (2.2) includes the gauge boson self-coupling, while it is not included into $V_{\mu\nu}$.

Using the standard Euler-Lagrange procedure we can obtain the following Maxwell

equations for the electromagnetic field:

$$\begin{aligned}
 \partial_\mu F^\mu{}_\nu &= J_\nu^\psi + ie \left[W_\mu^\dagger \partial_\nu W^\mu - W^\mu \partial_\nu W_\mu^\dagger + W_\nu^\dagger \partial_\mu W^\mu \right. \\
 &\quad \left. - W_\nu \partial_\mu W^{\mu\dagger} + 2W^\mu \partial_\mu W_\nu^\dagger - 2W^{\mu\dagger} \partial_\mu W_\nu \right] \\
 &\quad + e^2 \left[2A_\nu W_\mu^\dagger W^\mu - A^\mu (W_\mu^\dagger W_\nu + W_\mu W_\nu^\dagger) \right] \\
 &\quad + e^2 \cot \theta_W \left[2Z_\nu W_\mu^\dagger W^\mu - Z^\mu (W_\mu^\dagger W_\nu + W_\mu W_\nu^\dagger) \right], \tag{A.3}
 \end{aligned}$$

where J_ν^ψ is the electromagnetic current of the charged fermions. All the rest in the right hand side of (A.3) can be understood as the electromagnetic current of W bosons, J_μ^W .

Equations of motion for the other vector fields, W^\pm and Z , can be obtained from the Lagrangians (A.1, A.2) plus the contributions from the kinetic and mass terms. Explicitly we have:

$$\begin{aligned}
 \partial_\mu W_\nu^\mu + m_W^2 W_\nu &= ie \left[A^\mu W_{\mu\nu} - \partial_\mu (W^\mu A_\nu) + \partial_\mu (W_\nu A^\mu) - W^\mu F_{\mu\nu} \right] \\
 &\quad + ie \cot \theta_W \left[Z^\mu W_{\mu\nu} + \partial_\mu (Z^\mu W_\nu) - \partial_\mu (W^\mu Z_\nu) + W^\nu Z_{\nu\mu} \right] \\
 &\quad + (e^2 / \sin^2 \theta_W) \left[W_\nu (W_\mu^\dagger W_\mu) - W_\nu^\dagger (W^\mu W_\mu) \right] \\
 &\quad + e^2 \cot^2 \theta_W (W_\nu Z_\mu Z^\mu - Z_\nu Z_\mu W^\mu) \\
 &\quad + e^2 \cot \theta_W (2W_\nu Z_\mu A^\mu - Z_\nu W_\mu A^\mu - A_\nu W_\mu Z_\mu) \\
 &\quad + e^2 (W_\nu A^\mu A_\mu - A_\nu W_\mu A_\mu), \tag{A.4}
 \end{aligned}$$

$$\begin{aligned}
 \partial_\mu Z_\nu^\mu + m_Z^2 Z_\nu &= ie \cot \theta_W \left[W^\mu W_{\mu\nu}^\dagger - W^{\mu\dagger} W_{\mu\nu} + \partial_\mu (W^\mu W_\nu^\dagger) - \partial_\mu (W^{\mu\dagger} W_\nu) \right] \\
 &\quad + e^2 \cot^2 \theta_W (2Z_\nu W_\mu^\dagger W^\mu - W_\nu^\dagger W_\mu W^\mu - W_\nu W_\mu^\dagger Z^\mu) \\
 &\quad + e^2 \cot \theta_W (2A_\nu W_\mu^\dagger W^\mu - W_\nu^\dagger W_\mu A^\mu - W_\nu W_\mu^\dagger A_\mu). \tag{A.5}
 \end{aligned}$$

Appendix B

Correlation functions for several perturbations

In this Appendix we introduce spectrum and bispectrum for several perturbations. A similar problem was considered in [118] for a mixture of curvature and isocurvature perturbations.

We consider several observable quantities X^I , like ζ and S , which depend on “primordial” scalar fields ϕ^a , whose perturbations are generated during inflation. Up to second order, one can formally write

$$X^I = N_a^I \phi^a + \frac{1}{2} N_{ab}^I \phi^a \phi^b + \dots \quad (\text{B.1})$$

We assume that the ϕ^a are Gaussian random fields, with the two-point correlation functions

$$\langle \phi^a(\vec{k}) \phi^b(\vec{k}') \rangle = (2\pi)^3 P^{ab}(k) \delta(\vec{k} + \vec{k}'). \quad (\text{B.2})$$

In analogy with the case considered in section 4.4, we can expand the temperature fluctuations in spherical harmonics:

$$a_{lm} \equiv \int d^2\hat{n} \frac{\Delta T(\hat{n})}{T} Y_{lm}^*(\hat{n}), \quad \frac{\Delta T(\hat{n})}{T} = \sum_{lm} a_{lm} Y_{lm}(\hat{n}). \quad (\text{B.3})$$

In the multi-perturbation case, the total temperature anisotropy and the corresponding spherical harmonics coefficients can be written as a sum over the individual contributions:

$$\frac{\Delta T(\hat{n})}{T} = \sum_I \frac{\Delta T(\hat{n})^I}{T}, \quad a_{lm} = \sum_I a_{lm}^I. \quad (\text{B.4})$$

Appendix B. Correlation functions for several perturbations

As for the case of one perturbation, the temperature anisotropies can be Fourier expanded and, by using the Legendre expansion of the exponential, one finds:

$$\frac{\Delta T^I(\hat{n})}{T} = \int \frac{d^3k}{(2\pi)^3} \sum_l (i)^l (2l+1) g_l^I(k) X^I(\vec{k}) P_l(\hat{k} \cdot \hat{n}), \quad (\text{B.5})$$

where $P_l(\hat{k} \cdot \hat{n})$ are the Legendre polynomials and $g_l^I(k)$ are the photon transfer functions. As a consequence,

$$a_{lm}^I = 4\pi i^l \int \frac{d^3k}{(2\pi)^3} g_l^I(k) X^I(\vec{k}) Y_{lm}^*(\vec{k}) \quad (\text{B.6})$$

where we have used the addition theorem:

$$\sum_{m=-l}^l Y_{lm}^*(\hat{n}) Y_{lm}(\hat{n}') = \frac{2l+1}{4\pi} P_l(\hat{n} \cdot \hat{n}') \quad (\text{B.7})$$

and the orthonormality of spherical harmonics, $\int Y_{lm} Y_{l'm'}^* d\Omega = \delta_{ll'} \delta_{mm'}$.

Two-point correlation functions The total temperature spectrum is given by:

$$\langle a_{lm} a_{l'm'}^* \rangle = \sum_{IJ} C_l^{IJ} \delta_{ll'} \delta_{mm'}, \quad (\text{B.8})$$

where

$$C_l^{IJ} = \frac{2}{\pi} \int_0^\infty dk k^2 g_l^I(k) g_l^J(k) P^{IJ}(k). \quad (\text{B.9})$$

and $P^{IJ}(k)$ are the spectra of the X^I , defined as:

$$\langle X^I(\vec{k}) X^J(\vec{k}') \rangle = (2\pi)^3 P_{IJ}(k) \delta(\vec{k} + \vec{k}'). \quad (\text{B.10})$$

Three-point correlation functions We define the bispectra of the X^I by

$$\langle X_{\vec{k}_1}^I X_{\vec{k}_2}^J X_{\vec{k}_3}^K \rangle = (2\pi)^3 \delta(\sum_i \vec{k}_i) B^{IJK}(k_1, k_2, k_3). \quad (\text{B.11})$$

Substituting the decomposition (B.1) into the left hand side, and using (B.2), one finds

$$\begin{aligned} B^{IJK}(k_1, k_2, k_3) &= N_a^I N_b^J N_{cd}^K P^{ac}(k_1) P^{bd}(k_2) + N_a^I N_{bc}^J N_d^K P^{ab}(k_1) P^{cd}(k_3) \\ &\quad + N_{ab}^I N_c^J N_d^K P^{ac}(k_2) P^{bd}(k_3). \end{aligned} \quad (\text{B.12})$$

As shown in [96; 97], the angular bispectrum can be expressed in terms of the

Appendix B. Correlation functions for several perturbations

”reduced bispectrum” $b_{l_1 l_2 l_3}$, according to equation (4.43):

$$\langle a_{l_1 m_1} a_{l_2 m_2} a_{l_3 m_3} \rangle = \mathcal{G}_{l_1 l_2 l_3}^{m_1 m_2 m_3} b_{l_1 l_2 l_3}, \quad (\text{B.13})$$

where $\mathcal{G}_{l_1 l_2 l_3}^{m_1 m_2 m_3}$ is the Gaunt integral. Substituting (B.6) in the left hand side of (B.13), one finally obtains

$$b_{l_1 l_2 l_3} = 3 \sum_{I, J, K} N_{ab}^I N_c^J N_d^K \int_0^\infty r^2 dr \tilde{\beta}_{(l_1)}^I(r) \beta_{l_2}^{J, ac}(r) \beta_{l_3}^{K, bd}(r), \quad (\text{B.14})$$

with

$$\tilde{\beta}_l^I(r) \equiv \frac{2}{\pi} \int k^2 dk j_l(kr) g_l^I(k), \quad \beta_l^{I, ab}(r) \equiv \frac{2}{\pi} \int k^2 dk j_l(kr) g_l^I(k) P^{ab}(k). \quad (\text{B.15})$$

Note that the “reduced” bispectrum is symmetric with respect to permutations of the indices l_1 , l_2 and l_3 (we use the standard notation: $(l_1 l_2 l_3) \equiv [l_1 l_2 l_3 + 5 \text{ perms}]/3!$).

In the simplest case, one considers only the adiabatic mode, ζ (or the gravitational potential Φ), which is assumed to depend on a single “primordial” Gaussian field. In this case, where both the indices I and a take a single value, one recovers immediately the familiar result of [96], which we presented in section 4.4. Our general expression also includes the particular situation considered in [117], where $\zeta = \phi + (3/5)f_{NL}\phi^2$ and $S = \eta + f_{NL}^{\text{iso}}\eta^2$, ϕ and η being Gaussian variables.

Appendix C

Second order coefficients for the model with two curvatons

In this appendix we give the expressions for the second order coefficients of curvature and isocurvature perturbations for the model with two curvatons. Since they are lengthy and it is physically reasonable to have small energy fraction of dark matter at both the decay epochs, the assumption $x_{c1} = x_{c2} = 0$ is done for simplicity.

$$\begin{aligned}
 9 z_{\sigma\chi} &= 3f_{\chi 1} x_{r2}(f_{\chi 1} - 1) + x_{\chi 1}(1 - x_{r2})(\tilde{r}_1 - 4x_{r1} + 4x_{\chi 1}) \\
 &\quad + x_{r2}F_1(4x_{r2} - 2\tilde{r}_2 + \tilde{r}_2^2 - 3)
 \end{aligned} \tag{C.1}$$

$$\begin{aligned}
 18 z_{\sigma\sigma} &= -2f_{\chi 1}^2 x_{r2}(4x_{r2} + \tilde{r}_2^2 - 2\tilde{r}_2) - 2x_{r1}^2[4 + x_{r2}(-7 + 4x_{r2} + \tilde{r}_2^2 - 2\tilde{r}_2)] \\
 &\quad + f_{\chi 1} x_{r2}[3 - 4x_{\chi 1}(-3 + 4x_{r2} + \tilde{r}_2^2 - 2\tilde{r}_2)] \\
 &\quad + x_{\chi 1}\{(3 + 4\tilde{r}_1)(-1 + x_{r2}) - 2x_{\chi 1}[4 + x_{r2}(-7 + 4x_{r2} + \tilde{r}_2^2 - 2\tilde{r}_2)]\} \\
 &\quad + x_{r1}\{3 + 2\tilde{r}_1(1 - x_{r2})(2 - \tilde{r}_1) + x_{r2}[-3 + 4f_{\chi 1}(-3 + 4x_{r2} + \tilde{r}_2^2 - 2\tilde{r}_2)] \\
 &\quad + 16x_{\chi 1} + 4x_{r2}x_{\chi 1}(-7 + 4x_{r2} + \tilde{r}_2^2 - 2\tilde{r}_2)\}
 \end{aligned} \tag{C.2}$$

$$\begin{aligned}
 18 z_{\chi\chi} &= x_{\chi 1}(3 - 8x_{\chi 1}) - 8x_{r2}^2(1 - f_{\chi 1} - x_{\chi 1})^2 \\
 &\quad + x_{r2}\left\{(1 - f_{\chi 1})[3 - 2\tilde{r}_2(-2 + \tilde{r}_2)(1 - f_{\chi 1})] + 2x_{\chi 1}^2[7 - \tilde{r}_2(-2 + \tilde{r}_2)]\right\}
 \end{aligned}$$

Appendix C. Second order coefficients for the model with two curvatons

$$-x_{\chi 1} [15 - 12f_{\chi 1} - 4\tilde{r}_2(-2 + \tilde{r}_2)(1 - f_{\chi 1})] \} \quad (\text{C.3})$$

$$\begin{aligned} 3s_{\sigma\chi} = & -3f_{c1}f_{c2}(1 - f_{\chi 1})(1 - f_{c2}) - 3f_{c2}^2 f_{\chi 1}(1 - f_{\chi 1}) \\ & -x_{r2}[-3f_{\chi 1}(1 - f_{\chi 1}) + F_1(-3 + 4x_{r2} + \tilde{r}_2^2 - 2\tilde{r}_2)] \\ & +x_{\chi 1}(4x_{r1} - \tilde{r}_1)(1 - x_{r2}) - 4x_{\chi 1}^2(1 - x_{r2}) \end{aligned} \quad (\text{C.4})$$

$$\begin{aligned} s_{\sigma\sigma} = & -6f_{c1}^2(1 - f_{c2})^2 + 3f_{\chi 1}f_{c2} - 6f_{c2}^2f_{\chi 1}^2 + 3f_{c1}(1 - f_{c2})(1 - 4f_{c2}f_{\chi 1}) \\ & +f_{\chi 1}x_{r2}[-3 + 2f_{\chi 1}(4x_{r2} + \tilde{r}_2^2 - 2\tilde{r}_2)] + x_{r1}[-3 + 2\tilde{r}_1(-2 + \tilde{r}_1) + 8x_{r1}] \\ & +x_{r1}x_{r2}[3 - 2\tilde{r}_1(-2 + \tilde{r}_1) - 4f_{\chi 1}(-3 + 4x_{r2} + \tilde{r}_2^2 - 2\tilde{r}_2) \\ & +2x_{r1}(-7 + 4x_{r2} + \tilde{r}_2^2 - 2\tilde{r}_2)] + 2x_{\chi 1}^2[4 + x_{r2}(-7 + 4x_{r2} + \tilde{r}_2^2 - 2\tilde{r}_2)] \\ & +x_{\chi 1}\{3 + 4\tilde{r}_1(1 - x_{r2}) - x_{r2}[3 - 4f_{\chi 1}(-3 + 4x_{r2} + \tilde{r}_2^2 - 2\tilde{r}_2)] \\ & -4x_{r1}[4 + x_{r2}(-7 + 4x_{r2} + \tilde{r}_2^2 - 2\tilde{r}_2)]\} \end{aligned} \quad (\text{C.5})$$

$$\begin{aligned} 6s_{\chi\chi} = & 3f_{c2}(1 - f_{\chi 1}) - 6f_{c2}^2(1 - f_{\chi 1})^2 + 8x_{r2}^2(1 - f_{\chi 1} - x_{\chi 1})^2 + x_{\chi 1}(-3 + 8x_{\chi 1}) \\ & +x_{r2}\{-[3 - 2\tilde{r}_2(-2 + \tilde{r}_2)(1 - f_{\chi 1})](1 - f_{\chi 1}) + 2x_{\chi 1}^2[-7 + \tilde{r}_2(-2 + \tilde{r}_2)] \\ & +x_{\chi 1}[15 - 4\tilde{r}_2(-2 + \tilde{r}_2) + 4f_{\chi 1}(-3 + \tilde{r}_2)(1 + \tilde{r}_2)]\}, \end{aligned} \quad (\text{C.6})$$

where $F_1 \equiv (1 - f_{\chi 1} - x_{\chi 1})(x_{r1} - f_{\chi 1} - x_{\chi 1})$ was used.

Bibliography

- [1] M. H. Anderson, J. R. Ensher, M. R. Matthews, C. E. Wieman, and E. A. Cornell, *Science* **269** (1995) 198.
- [2] J. Klaers, J. Schmitt, F. Vewinger, and M. Weitz *Nature* **468** (2010) 545.
- [3] C. J. Pethick and H. Smith, *'Bose-Einstein Condensation in Dilute Gases*, Cambridge University Press, 2002.
- [4] G. Gabadadze and R. A. Rosen, *JCAP* **0810** (2008) 030 [arXiv:0806.3692 [astro-ph]].
- [5] A. D. Linde, *Phys. Lett. B* **86** (1979) 39;
A. D. Linde, *Phys. Rev. D* **14** (1976) 3345.
D.Yu. Grigoriev, D.V. Deryagin, V.A. Rubakov, *Pis'ma ZhETF*, **44** (1986) 301;
D.V. Deryagin, D.Yu. Grigoriev, V.A. Rubakov, *Phys. Lett. B* **178** (1986) 385
D.V. Deryagin, D.Yu. Grigoriev, V.A. Rubakov, *Int. J. Mod. Phys. A***3** (1988)1199;
V.A. Matveev, V.A. Rubakov, A.N. Tavkhelidze, M.E. Shaposhnikov, *Usp. Fiz. Nauk* **156** (1988) 253, English translation: *Sov. Phys. Usp.* **31** (1988) 916;
- [6] A. D. Dolgov, A. Lepidi and G. Piccinelli, *JCAP* **1008**, 031 (2010) [arXiv:1005.2702 [astro-ph.CO]].
- [7] L. Berezhiani, G. Gabadadze and D. Pirtskhalava, *JHEP* **1004** (2010) 122 [arXiv:1003.0865 [hep-ph]].
- [8] P. F. Bedaque, M. I. Buchoff and A. Cherman, arXiv:1007.1972 [hep-ph].
- [9] A. D. Dolgov, A. Lepidi and G. Piccinelli, *JCAP* **0902** (2009) 027 [arXiv:0811.4406 [hep-th]].
- [10] A. D. Dolgov, A. Lepidi and G. Piccinelli, *Phys. Rev. D* **80** (2009) 125009 [arXiv:0905.4422 [hep-ph]].
- [11] A. Lepidi, arXiv:1004.1010 [hep-th].
- [12] G. Gabadadze and R. A. Rosen, *JCAP* **0902** (2009) 016 [arXiv:0811.4423 [hep-th]].

-
- [13] G. Gabadadze and R. A. Rosen, JHEP **0907** (2009) 093 [arXiv:0905.2444 [hep-th]].
- [14] G. Gabadadze and R. A. Rosen, JCAP **1004** (2010) 028 [arXiv:0912.5270 [hep-ph]].
- [15] R. A. Rosen, JHEP **1012**, 024 (2010). [arXiv:1009.0752 [hep-th]].
- [16] M. Mirbabayi, Phys. Lett. **B696** (2011) 13-15. [arXiv:1010.2544 [astro-ph.SR]].
- [17] L.D. Landau and E.M. Lifshitz *Landau and Lifshitz, Course of Theoretical Physics, Volume 9 - Statistical Physics part 2*, Pergamon Press Ltd, 1980.
- [18] J. I. Kapusta, Phys. Rev. D **24** (1981) 426.
H. E. Haber and H. A. Weldon, Phys. Rev. D **25** (1982) 502.
- [19] A.D. Dolgov, Pisma Zh. Eksp. Teor. Fiz. **29** (1979) 254; LETP Letters, **29** (1979) 228.
- [20] R.A. Littleton and H. Bondi, Proc. Roy. Soc. (London), **A252** (1959) 313;
A. Barnes, The Astrophysical Journal, **227**:1-12, 1979;
E. Masso and F. Rota, Phys. Lett. B **545** (2002) 221 [arXiv:astro-ph/0201248];
A. Dolgov and J. Silk, Phys. Rev. D **47** (1993) 3144;
C. Caprini, S. Biller and P. G. Ferreira, JCAP **0502** (2005) 006 [arXiv:hep-ph/0310066].
- [21] T. P. Cheng, L. F. Li, "Gauge Theory Of Elementary Particle Physics," Oxford, Uk: Clarendon (1984) 536 P. (Oxford Science Publications).
- [22] E. Leader, E. Predazzi, Camb. Monogr. Part. Phys. Nucl. Phys. Cosmol. **3** (1996) 1.
- [23] Y. Nambu, Phys. Rev. Lett. **4** (1960) 380.
Y. Nambu and G. Jona-Lasinio, Phys. Rev. **124** (1961) 246.
Y. Nambu and G. Jona-Lasinio, Phys. Rev. **122** (1961) 345.
J. Goldstone, Nuovo Cim. **19** (1961) 154.
J. Goldstone, A. Salam and S. Weinberg, Phys. Rev. **127** (1962) 965.
- [24] P. W. Higgs, Phys. Lett. **12** (1964) 132. P. W. Higgs, Phys. Rev. **145** (1966) 1156.
- [25] D.A. Kirzhnits, JETP Letters, **15** (1972) 529;
D.A. Kirzhnits and A.D. Linde Phys. Lett. B **42** (1972) 471
- [26] A. D. Linde, *Particle Physics and Inflationary Cosmology*, Harwood, Chur, Switzerland, 1990, arXiv:hep-th/0503203.

-
- [27] K. Rummukainen, M. Tsypin, K. Kajantie *et al.*, Nucl. Phys. **B532** (1998) 283-314. [hep-lat/9805013].
- [28] T. D. Lee, G. C. Wick, Phys. Rev. **D9** (1974) 2291.
- [29] S. L. Adler, Phys. Rev. **177** (1969) 2426-2438.
J. S. Bell, R. Jackiw, Nuovo Cim. **A60** (1969) 47-61.
- [30] M. E. Peskin, D. V. Schroeder, Reading, USA: Addison-Wesley (1995) 842 p.
- [31] G. 't Hooft, Phys. Rev. Lett. **37** (1976) 8-11; Phys. Rev. **D14** (1976) 3432-3450.
- [32] V. A. Kuzmin, V. A. Rubakov, M. E. Shaposhnikov, Phys. Lett. **B155** (1985) 36.
V. A. Matveev, V. A. Rubakov, A. N. Tavkhelidze *et al.*, Sov. Phys. Usp. **31** (1988) 916-939.
- [33] G. D. Moore, arXiv:hep-ph/0009161.
- [34] K.-I. Aoki, Phys. Lett. B **174** (1986) 371;
J. A. Harvey and M. S. Turner, Phys. Rev. D **42** (1990) 3344;
A.E. Nelson and S.M. Barr, Phys. Lett b **246** (1990) 141;
A.D. Dolgov, Phys. Repts. **222** (1992) 309.
- [35] E. J. Ferrer, V. de la Incera and A. E. Shabad, Phys. Lett. B **185** (1987) 407.
- [36] J. I. Kapusta, Phys. Rev. D **42** (1990) 919;
- [37] O. K. Kalashnikov and H. Perez Rojas, Phys. Rev. D **40** (1989) 1255.
- [38] M. Chaichian, R. Gonzalez Felipe, D. Louis Martinez and H. Perez Rojas, CERN-TH-5870-90, Sep 1990.
- [39] J. I. Kapusta, C. Gale, *Finite temperature field theory: Principles and Applications*, Cambridge Monographs on Mathematical Physics, 2006.
M. Le Bellac, *Quantum And Statistical Field Theory*, Oxford, UK: Clarendon (1991).
- [40] A. D. Dolgov, S. H. Hansen, S. Pastor, S. T. Petcov, G. G. Raffelt and D. V. Semikoz, Nucl. Phys. B **632**, 363 (2002) [arXiv:hep-ph/0201287].
- [41] P. D. Serpico and G. G. Raffelt, Phys. Rev. D **71** (2005) 127301 [arXiv:astro-ph/0506162].
- [42] S. Pastor, T. Pinto and G. G. Raffelt, Phys. Rev. Lett. **102** (2009) 241302 [arXiv:0808.3137 [astro-ph]].

- [43] A. D. Dolgov and F. Takahashi, Nucl. Phys. B **688** (2004) 189.
- [44] F. Iocco, G. Mangano, G. Miele *et al.*, Phys. Rept. **472** (2009) 1-76.
[arXiv:0809.0631 [astro-ph]].
- [45] E. Komatsu *et al.* [WMAP Collaboration], Astrophys. J. Suppl. **192** (2011) 18.
[arXiv:1001.4538 [astro-ph.CO]].
- [46] A. D. Sakharov, Pisma Zh. Eksp. Teor. Fiz. **5**, 32-35 (1967).
- [47] A. Casas, W. Y. Cheng and G. Gelmini, Nucl. Phys. B **538** (1999) 297 [arXiv:hep-ph/9709289].
- [48] H.E. Haber and H.A. Weldon, Phys. Rev. D **25** (1982) 502.
K.M. Benson, J. Bernstein and S. Dodelson, Phys. Rev. D **44** (1991) 2480.
A. Riotto and G. Senjanović, Phys. Rev. Lett. **79** (1997) 349
J. Liu and G. Segre, Phys. Lett. B **338** (1994) 259.
B. Bajc, A. Riotto and G. Senjanović, Phys. Rev. Lett. **81** (1998) 1355
- [49] A. D. Dolgov, Phys. Atom. Nucl. **73** (2010) 815-847. [arXiv:0907.0668 [hep-ph]].
- [50] J.A. Harvey and E.W. Kolb, Phys. Rev.D **24** (1981) 2090;
A.D. Dolgov and D.P. Kirilova, J. Moscow Phys. Soc. **1** (1991) 217.
- [51] J. McDonald, Phys. Rev. Lett. **84**, 4798 (2000) [arXiv:hep-ph/9908300].
- [52] A. D. Dolgov, Phys. Rept. **370**, 333 (2002) [arXiv:hep-ph/0202122].
- [53] I. Affleck and M. Dine, Nucl. Phys. B **249**, 361 (1985).
- [54] E.M. Lifshitz and L.P Pitaevskii, *Landau and Lifshitz, Course of Theoretical Physics, Volume 10 - Physical Kinetics*, Elsevier (1981).
- [55] J. Friedel, Phil. Mag. **43**, 153 (1952); Nuovo Cim. **7**, 287 (1958), suppl. 2;
J.S. Langer, S.H. Vosko, J. Phys. Chem. Solids, **12**, 196 (1960).
- [56] A. Fetter, J. Walecka, *Quantum Theory of Many-Particle Systems*, McGraw-Hill, San Francisco, 1971.
- [57] U. Kraemmer, A. K. Rebhan and H. Schulz, Annals Phys. **238** (1995) 286
[arXiv:hep-ph/9403301].
- [58] K. Yagi, T. Hatsuda, Y. Miake, *Quark-Gluon Plasma: From Big Bang to Little Bang*, Cambridge Monographs on Particle Physics, Nuclear Physics and Cosmology (No. 23), October, 2008.

-
- [59] A. D. Dolgov, [arXiv:1009.1941 [astro-ph.CO]].
- [60] G. Gabadadze and D. Pirtskhalava, JCAP **0905** (2009) 017 [arXiv:0904.4267 [hep-th]].
- [61] J. Diaz-Alonso, A. Perez, H.D. Sivak, Prog. Theor. Phys. **105**, 961 (2001), arXiv: hep-ph/9803344; Nucl. Phys. A **505**, 695 (1989).
- [62] C. Mu, P. Zhuang, Eur.Phys.J. C **58**, 271 (2008), arXiv:0803.0581 [nucl-th].
- [63] W. Detmold, M.J. Savage, Phys.Rev.Lett. **102**, 032004 (2009), arXiv:0809.0892 [hep-lat].
- [64] A. Pich, arXiv:0705.4264 [hep-ph].
- [65] W. A. Bardeen, R. Gastmans and B. Lautrup, Nucl. Phys. B **46** (1972) 319.
- [66] S. Schael *et al.* [ALEPH Collaboration], Phys. Lett. B **614** (2005) 7.
- [67] A. D. Linde, Rept. Prog. Phys. **42** (1979) 389.
- [68] N.W. Ashcroft, N.D. Mermin, *Solid State Physics*, Harcourt College Publisher, 1976.
- [69] V.B. Berestetskii, E.M. Lifshitz and L.P Pitaevskii, *Landau and Lifshitz, Course of Theoretical Physics, Volume 4 - Quantum Electrodynamics*, Elsevier, 1982.
- [70] T. L. Ho, Phys. Rev. Lett. **81** (1998) 742.
- [71] C.K. Law, H. Pu, N.P. Bigelow, Phys. Rev. Lett. **81** (1998) 5257.
- [72] T.-L. Ho, S.K. Yip, Phys. Rev. Lett. **84** (2000) 4031.
- [73] W. Zhang, D.L. Zhou, M.-S. Chang, M.S. Chapman, L. You, Phys. Rev. Lett. **95** (2005) 180403-1.
- [74] P. Olesen, On the possible creation of a background W condensate in the electroweak phase transition. Phys. Lett. B **281** (1992) 30;
J. Ambjorn, P. Olesen, Electroweak magnetism, W condensation and antiscreening. NBI-HE-93-17, Sep 1992, based on an invited talk given at 4th HellenicSchool on Elementary Particle Physics, Corfu, Greece, 2-20 Sep 1992; *Korfu 1992, Elementary particle physics, vol. 1, 396; e-Print: hep-ph/9304220.
- [75] A. D. Linde, Rep. Prog. Phys. **42** (1979) 389;
A. D. Linde, Phys. Lett. **96B** (1980) 293;
D. J. Gross, R. Pisarski, L. Yaffe, Rev. Mod. Phys. **53** (1981) 43.

-
- [76] D. Grasso and H. R. Rubinstein, *Phys. Rept.* **348** (2001) 163 [arXiv:astro-ph/0009061].
A.D. Dolgov In Gurzadyan, V.G. (ed.) et al.: From integrable models to gauge theories, 143-154. e-Print: hep-ph/0110293
A.D. Dolgov, Talk given at 17th Les Rencontres de Physique de la Vallée d'Aoste: Results and Perspectives in Particle Physics, La Thuile, Aosta Valley, Italy, 9-15 Mar 2003, e-Print: astro-ph/0306443
M. Giovannini, *Int. J. Mod. Phys. D* **13** (2004) 391 [arXiv:astro-ph/0312614].
- [77] M. Quiros, arXiv:hep-ph/9901312.
U. Kraemmer and A. Rebhan, *Rept. Prog. Phys.* **67** (2004) 351 [arXiv:hep-ph/0310337].
- [78] A. K. Rebhan, *Phys. Rev. D* **48** (1993) 3967 [arXiv:hep-ph/9308232].
- [79] S. Leupold and M. H. Thoma, *Phys. Lett. B* **465** (1999) 249 [arXiv:hep-ph/9908460].
- [80] I. A. Akhiezer and C. V. Peletminsky, *ZhETF* **38** (1960) 1829 [*Sov. Phys. JETP*, **11** (1960) 1316]; E. S. Fradkin, *Proc. Lebedev Inst.* **29** (1965) 6.
- [81] H. D. Sivak, *Physica* **A129** 408 (1985);
J. I. Kapusta and T. Toimela, *Phys. Rev. D* **37**, 3731 (1988).
- [82] D. Langlois, *Lect. Notes Phys.* **800**, 1 (2010) [arXiv:1001.5259 [astro-ph.CO]].
- [83] [Planck Collaboration], “The Scientific programme of planck,” [astro-ph/0604069].
- [84] V. Mukhanov, “Physical foundations of cosmology,” Cambridge, UK: Univ. Pr. (2005) 421 p.
- [85] S. Weinberg, “Cosmology,” Oxford, UK: Oxford Univ. Pr. (2008) 593 p.
- [86] A. Riotto, CERN Yellow Report CERN-2010-001, 315-362. [arXiv:1010.2642 [hep-ph]].
- [87] D. Langlois and F. Vernizzi, *Phys. Rev. Lett.* **95**, 091303 (2005) [arXiv:astro-ph/0503416].
- [88] D. Langlois and F. Vernizzi, *Phys. Rev. D* **72**, 103501 (2005) [arXiv:astro-ph/0509078].
- [89] D. Langlois and F. Vernizzi, *Class. Quant. Grav.* **27**, 124007 (2010) [arXiv:1003.3270 [astro-ph.CO]].

-
- [90] K. A. Malik, D. Wands, Phys. Rept. **475** (2009) 1-51. [arXiv:0809.4944 [astro-ph]].
- [91] D. Langlois and F. Vernizzi, JCAP **0602**, 014 (2006) [arXiv:astro-ph/0601271].
- [92] D. H. Lyth, K. A. Malik and M. Sasaki, JCAP **0505**, 004 (2005) [arXiv:astro-ph/0411220].
- [93] M. Bucher, K. Moodley, N. Turok, Phys. Rev. **D62** (2000) 083508. [astro-ph/9904231].
- [94] Y. . B. Zeldovich, R. A. Sunyaev, Astrophys. Space Sci. **4** (1969) 301, Comments Astrophys. Space Phys. **4** (1972) 173-178.
- [95] R. K. Sachs, A. M. Wolfe, Astrophys. J. **147** (1967) 73-90.
- [96] E. Komatsu, D. N. Spergel, Phys. Rev. **D63**, 063002 (2001). [astro-ph/0005036].
- [97] L. -M. Wang, M. Kamionkowski, Phys. Rev. **D61**, 063504 (2000). [astro-ph/9907431].
- [98] D. Langlois and A. Riazuelo, Phys. Rev. D **62**, 043504 (2000) [arXiv:astro-ph/9912497].
- [99] A. D. Linde and V. F. Mukhanov, Phys. Rev. D **56** (1997) 535 [arXiv:astro-ph/9610219]. K. Enqvist and M. S. Sloth, Nucl. Phys. B **626**, 395 (2002) [arXiv:hep-ph/0109214]; D. H. Lyth and D. Wands, Phys. Lett. B **524**, 5 (2002) [arXiv:hep-ph/0110002]; T. Moroi and T. Takahashi, Phys. Lett. B **522**, 215 (2001) [Erratum-ibid. B **539**, 303 (2002)] [arXiv:hep-ph/0110096].
- [100] D. H. Lyth, C. Ungarelli and D. Wands, Phys. Rev. D **67**, 023503 (2003) [arXiv:astro-ph/0208055].
- [101] D. H. Lyth and D. Wands, Phys. Rev. D **68**, 103516 (2003) [arXiv:astro-ph/0306500].
- [102] M. Lemoine and J. Martin, Phys. Rev. D **75**, 063504 (2007) [arXiv:astro-ph/0611948].
- [103] M. Lemoine, J. Martin and G. Petit, Phys. Rev. D **78**, 063516 (2008) [arXiv:0802.1601 [astro-ph]].
- [104] M. Lemoine, J. Martin and J. Yokoyama, Phys. Rev. D **80**, 123514 (2009) [arXiv:0904.0126 [astro-ph.CO]].

-
- [105] M. Bucher, K. Moodley, N. Turok, Phys. Rev. Lett. **87**, 191301 (2001). [astro-ph/0012141].
- [106] N. Bartolo, E. Komatsu, S. Matarrese *et al.*, Phys. Rept. **402**, 103-266 (2004). [astro-ph/0406398].
- [107] N. Bartolo, S. Matarrese, A. Riotto, [arXiv:1001.3957 [astro-ph.CO]].
- [108] T. Suyama, T. Takahashi, M. Yamaguchi *et al.*, [arXiv:1009.1979 [astro-ph.CO]].
- [109] D. Wands, Class. Quant. Grav. **27**, 124002 (2010) [arXiv:1004.0818 [astro-ph.CO]].
- [110] C. T. Byrnes and K. Y. Choi, arXiv:1002.3110 [astro-ph.CO].
- [111] M. Zaldarriaga, Phys. Rev. D **69**, 043508 (2004) [arXiv:astro-ph/0306006].
- [112] F. Vernizzi, Phys. Rev. D **69**, 083526 (2004) [arXiv:astro-ph/0311167].
- [113] D. Langlois and L. Sorbo, JCAP **0908**, 014 (2009) [arXiv:0906.1813 [astro-ph.CO]].
- [114] J. M. Maldacena, JHEP **0305** (2003) 013. [astro-ph/0210603].
- [115] P. Creminelli, M. Zaldarriaga, JCAP **0410** (2004) 006. [astro-ph/0407059].
- [116] D. Langlois, F. Vernizzi and D. Wands, JCAP **0812**, 004 (2008) [arXiv:0809.4646 [astro-ph]].
- [117] C. Hikage, K. Koyama, T. Matsubara, T. Takahashi and M. Yamaguchi, Mon. Not. Roy. Astron. Soc. **398**, 2188 (2009) [arXiv:0812.3500 [astro-ph]].
- [118] M. Kawasaki, K. Nakayama, T. Sekiguchi, T. Suyama and F. Takahashi, JCAP **0901**, 042 (2009) [arXiv:0810.0208 [astro-ph]].
- [119] M. Beltran, Phys. Rev. D **78**, 023530 (2008) [arXiv:0804.1097 [astro-ph]].
- [120] M. Kawasaki, K. Nakayama, T. Sekiguchi, T. Suyama and F. Takahashi, JCAP **0811**, 019 (2008) [arXiv:0808.0009 [astro-ph]].
- [121] M. Kawasaki, K. Nakayama and F. Takahashi, JCAP **0901**, 002 (2009) [arXiv:0809.2242 [hep-ph]].
- [122] E. Kawakami, M. Kawasaki, K. Nakayama and F. Takahashi, JCAP **0909**, 002 (2009) [arXiv:0905.1552 [astro-ph.CO]].
- [123] T. Takahashi, M. Yamaguchi and S. Yokoyama, Phys. Rev. D **80**, 063524 (2009) [arXiv:0907.3052 [astro-ph.CO]].

- [124] P. Creminelli, A. Nicolis, L. Senatore *et al.*, JCAP **0605** (2006) 004. [astro-ph/0509029].
- [125] L. Senatore, K. M. Smith, M. Zaldarriaga, JCAP **1001** (2010) 028. [arXiv:0905.3746 [astro-ph.CO]].
- [126] A. Mazumdar, J. Rocher, Submitted to: Phys.Rept.. [arXiv:1001.0993 [hep-ph]].
- [127] D. Langlois and F. Vernizzi, Phys. Rev. D **70**, 063522 (2004) [arXiv:astro-ph/0403258].
- [128] H. Assadullahi, J. Valiviita and D. Wands, Phys. Rev. D **76**, 103003 (2007) [arXiv:0708.0223 [hep-ph]].
- [129] D. Langlois, A. Lepidi, JCAP **1101** (2011) 008. [arXiv:1007.5498 [astro-ph.CO]].
- [130] F. Ferrer, S. Rasanen and J. Valiviita, JCAP **0410**, 010 (2004) [arXiv:astro-ph/0407300].
- [131] G. Lazarides, R. R. de Austri and R. Trotta, Phys. Rev. D **70**, 123527 (2004) [arXiv:hep-ph/0409335].
- [132] K. Hamaguchi, M. Kawasaki, T. Moroi and F. Takahashi, Phys. Rev. D **69**, 063504 (2004) [arXiv:hep-ph/0308174].
- [133] K. Y. Choi and J. O. Gong, JCAP **0706**, 007 (2007) [arXiv:0704.2939 [astro-ph]].
- [134] Q. G. Huang, JCAP **0809**, 017 (2008) [arXiv:0807.1567 [hep-th]].
- [135] D. Langlois, T. Takahashi, JCAP **1102** (2011) 020. [arXiv:1012.4885 [astro-ph.CO]].
- [136] S. Gupta, K. A. Malik and D. Wands, Phys. Rev. D **69**, 063513 (2004) [arXiv:astro-ph/0311562].
- [137] D. Langlois, Phys. Rev. D **59**, 123512 (1999) [arXiv:astro-ph/9906080].

Acknowledgements

I would like to acknowledge my tutor, Prof. Alexander Dolgov for the constructive discussions, for the constant encouraging and for his irreplaceable fun stories and jokes. I am grateful to my co-tutor, Prof. David Langlois for the availability and for having patiently guided my very first steps in a new field. I warmly thank the two of them for what they taught to me and even more for all the things that I haven't understood, for the constant support and for letting me take my time when I needed.

I thank Dr. Gabriella Piccinelli who was a coworker as well as a friend and, between an equation and another, taught me to take it easy.

The IDAPP program was a crucial part of my PhD and I warmly acknowledge all the organizers for providing me such a great opportunity. In particular, Prof. Giovanni Fiorentini for saying some time ago the right thing at the right time. Warm thanks to Alessandra Tonazzo and Paola Fabbri for the support and the patience and for preventing me from getting lost in the bureaucratic traps.

I am grateful to the members of the jury for my defense for the time they dedicated to me and to Prof. Steen Hansen, Dr. Alexander Kamenshchik, Prof. Georg Raffelt and Dr. Antonio Riotto for accepting to act as referees and for the useful comments on the manuscript.

I acknowledge the Physics Department in Ferrara and the APC laboratory in Paris together with their members for being the cradle where I grew up. In particular I acknowledge Dr. Alessandro Drago for his laughs, Dr. Denis Comelli for the talks and the two of them for the useful discussions. I am thankful to the IUSS in Ferrara for the logistic support.

Ringrazio Daniela (bzzzz) per aver condiviso il meglio, il peggio e soprattutto le parti più assurde di questo dottorato; Mimma per la cioccolata, Damian per i caffè, tutti gli altri amici di Ferrara per aver condiviso le giornate di nebbia e qualche pezzetto di questa avventura; Michela, Debora e tutta la brigata italiana a Parigi per avermi accolta e fatta sentire a casa; i "CROUS-guys" per i pranzi prelibati; gli altri dottorandi IDAPP per le tantissime risate. Je remercie Alex et Nathan de m'avoir aidée à traduire en français. Grazie a Federica e a tutti gli amici di L'Aquila per quanto è stato, ed è ancora ogni volta, incredibile rivederci.

La mia famiglia, la migliore che potessi sperare di avere, è stata fondamentale per il raggiungimento di questo traguardo. Ringrazio di cuore i miei genitori per aver dato l'esempio, per avermi insegnato ad avere il futuro come obiettivo e per aver creduto in me, sempre. Ringrazio le mie sorelle e le loro famiglie per l'affetto, per avermi ricordato l'incredibile bellezza delle cose semplici e per avermi riportata ogni tanto con i piedi per terra.

Un ringraziamento speciale va a Paolo per essere rimasto fermo mentre tutto intorno ballava. Grazie per i troppi viaggi, per il tempo che non basta mai, grazie a te e alla tua famiglia per avermi accolta con la naturalezza delle cose giuste.