

Technical University of Denmark



Demonstration of decision support for real time operation

Catterson, Victoria ; McArthur, Stephen; Chen, Minjiang; Pertl, Michael; Reigstad, Tor Inge ; Ciavarella, Roberto; Di Somma, Marialaura; Riaño, Sandra; Marinelli, Mattia; Zuelli, Roberto

Publication date:
2018

Document Version
Publisher's PDF, also known as Version of record

[Link back to DTU Orbit](#)

Citation (APA):
Catterson, V., McArthur, S., Chen, M., Pertl, M., Reigstad, T. I., Ciavarella, R., ... Zuelli, R. (2018). Demonstration of decision support for real time operation. ELECTRA Consortium.

DTU Library

Technical Information Center of Denmark

General rights

Copyright and moral rights for the publications made accessible in the public portal are retained by the authors and/or other copyright owners and it is a condition of accessing publications that users recognise and abide by the legal requirements associated with these rights.

- Users may download and print one copy of any publication from the public portal for the purpose of private study or research.
- You may not further distribute the material or use it for any profit-making activity or commercial gain
- You may freely distribute the URL identifying the publication in the public portal

If you believe that this document breaches copyright please contact us providing details, and we will remove access to the work immediately and investigate your claim.

Project No. 609687
FP7-ENERGY-2013-IRP

ELECTRA

European Liaison on Electricity Committed Towards long-term Research Activities for Smart Grids

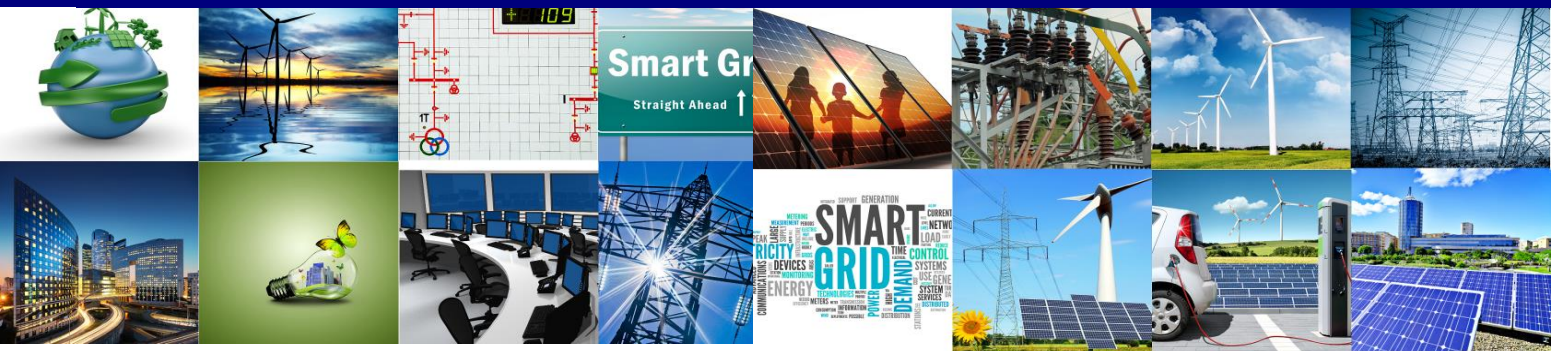

WP 8

Future Control Room Functionality

Deliverable 8.2

Demonstration of decision support for real time operation

02/02/2018

ID&Title	D8.2 Demonstration of decision support for real time operation	Number of pages:	43
Short description (Max. 50 words):			
ELECTRA Deliverable 8.2 reports on the demonstration of decision support within the future control room in light of voltage and frequency control in the 2030+ power system. The decision support must identify key threats and vulnerabilities, and propose and prioritise appropriate interventions.			
Version	Date	Modification's nature	
V0.1	28/07/2017	First Draft	
V0.02	02/08/2017	Revised Draft	
V0.03	07/08/2017	Final Draft	
V1.00	27/09/2017	Under review	
V2.00	02/02/2018	Released	
Accessibility			
<input checked="" type="checkbox"/> PU, Public			
<input type="checkbox"/> PP, Restricted to other program participants (including the Commission Services)			
<input type="checkbox"/> RE, Restricted to other a group specified by the consortium (including the Commission Services)			
<input type="checkbox"/> CO, Confidential, only for members of the consortium (including the Commission Services)			
If restricted, please specify here the group:			
Owner / Main responsible:			
Task T8.3 Leader:	Stephen McArthur (USTRATH)		
Reviewed by:			
Technical Project Coordinator:	Helfried Brunner (AIT) Carlo Tornelli (RSE)	01/02/2018	
Final Approval by:			
ELECTRA Technical Committee TOQA appointed Reviewer:	Luciano Martini	02/02/2018	

Authors

Name	Last Name	Organization	Country
Victoria	Catterson	USTRATH	UK
Stephen	McArthur	USTRATH	UK
Minjiang	Chen	USTRATH	UK
Michael	Pertl	DTU	DK
Tor Inge	Reigstad	SINTEF	NO
Roberto	Ciavarella	ENEA	IT
Marialaura	Di Somma	ENEA	IT
Sandra	Riaño	TECNALIA	SPAIN
Mattia	Marinelli	DTU	DK
Roberto	Zuelli	RSE	IT

Copyright

© Copyright 2013-2018 The ELECTRA Consortium

Consisting of:

Coordinator	
Ricerca Sul Sistema Energetico – (RSE)	Italy
Participants	
Austrian Institute of Technology GmbH - (AIT)	Austria
Vlaamse Instelling Voor Technologisch Onderzoek N.V. - (VITO)	Belgium
Belgisch Laboratorium Van De Elektriciteitsindustrie - (LABORELEC)	Belgium
Danmarks Tekniske Universitet - (DTU)	Denmark
Teknologian Tutkimuskeskus - (VTT)	Finland
Commissariat A L'Énergie Atomique Et Aux Énergies Alternatives - (CEA)	France
Fraunhofer-Gesellschaft Zur Förderung Der Angewandten Forschung E.V – (IWES)	Germany
Centre For Renewable Energy Sources And Saving - (CRESES)	Greece
Agenzia Nazionale per Le Nuove Tecnologie, L'Énergia E Lo Sviluppo Economico Sostenibile - (ENEA)	Italy
Fizikālas Enerģētikas Institūts - (IPE)	Latvia
SINTEF Energi AS - (SINTEF)	Norway
Instytut Energetyki - (IEN)	Poland
Instituto De Engenharia De Sistemas E Computadores Do Porto - (INESC_P)	Portugal
Fundacion Tecnalia Research & Innovation - (TECNALIA)	Spain
Joint Research Centre European Commission - (JRC)	Belgium
Nederlandse Organisatie Voor Toegepast Natuurwetenschappelijk Onderzoek – (TNO)	Netherlands
Türkiye Bilimsel Ve Teknolojik Arastirma Kurumu - (TUBITAK)	Turkey
University Of Strathclyde - (USTRATH)	UK
European Distributed Energy Resources Laboratories (DERlab)	Germany
Institute for Information Technology at University of Oldenburg (OFFIS)	Germany

This document may not be copied, reproduced, or modified in whole or in part for any purpose without written permission from the ELECTRA Consortium. In addition to such written permission to copy, reproduce, or modify this document in whole or part, an acknowledgment of the authors of the document and all applicable portions of the copyright notice must be clearly referenced.

All rights reserved.

This document may change without notice.

Executive summary

The present report considers the need for decision support systems (DSS) within the future control room of 2030+, in the context of the ELECTRA [1] Web of Cells (WoC) network architecture. The main aim is to identify critical decisions that must be made during the operation of a cell within the WoC, and to propose and demonstrate methods of supporting these decisions. The presented work is heavily based on the visualisation scenarios reported in ELECTRA D8.1 [2]. While D8.1 considers particular scenarios from initiating incident through to scenario resolution, and proposes new analytics and visualisations to assist the operator in resolving the situation, D8.2 focuses in detail on one or more decision points within these scenarios.

By building on the scenarios in D8.1, the research reported in this Deliverable provides novel solutions to a range of problems tackled from a Web of Cells functionality viewpoint. This extends to the consideration of autonomy and interaction with neighbouring cells absent in other research projects. The drive is to assess a range of solutions that can be combined within the WoC control, automation and decision support platform. The assessment of transient stability margins and critical clearing time, imbalance in tie line flow, loss of mains, over voltage curtailment and procurement of reserves (following single and double frequency deviations) are the scenarios. Within these, the learning arising includes:

- The casting of the problem for a WoC implementation, drawing out the unique opportunities to solve the issues within this context;
- Enhanced use of Optimal Power Flow within a WoC context;
- Effective use of storage to support WoC operation;
- Knowledge based and constraint satisfaction techniques; and,
- Interaction between the operator and automated systems within the WoC.

All of the above are linked and consider from a decision support perspective i.e. how would the system inform operators and take control as necessary.

Chapter 1 introduces some context and definitions to explain the need for decision support within the future control scenarios. Chapter 2 describes in detail the decision points where a DSS can be applicable, what the key actions are that could be taken, and which metrics are important for prioritisation of the actions. Chapter 3 presents the techniques and methods used for implementation of the decision support demonstrators, along with results of testing. Chapter 4 concludes with the learning and new knowledge derived from the design and specification of these demonstrators.

Terminologies

Abbreviations

BESS	Battery Energy Storage Systems
BRC	Balance Restoration Control
BSC	Balance Steering Control
CBS	Critical Bus Screening
CCGT	Combined Cycle Gas Turbines
CCT	Critical Clearing Time
CSP	Constraint Satisfaction Problem
DER	Distributed Energy Resource
DG	Distributed Generation
DMS	Distribution Management System
DSS	Decision Support System
ELECTRA IRP	European Liaison On Electricity Committed Towards Long-Term Research Activity Integrated Research Programme
ESB	Energy Safety Band
FCC	Frequency Containment Control
KB	Knowledge Base
MOC	Merit Order Collection
MOD	Merit Order Decision
MS	Milestone
OPF	Optimal Power Flow
PMU	Phasor Measurement Unit
PPVC	Post-Primary Voltage Control
RES	Renewable Energy Sources
RDSS	RSE Decision Support System
SCADA	Supervisory Control and Data Acquisition
SG	Synchronous Generator
SLD	Single Line Diagram
SOC	State Of Charge
SOR	Speed Of Response
TD	Time Domain
UDSS	USTRATH Decision Support System
WoC	Web-of-Cells

Table of contents

1. Introduction and methodology	10
1.1 Decision support for human operators within a Web of Cells	10
1.2 ELECTRA Control Room Scenarios.....	11
1.3 Decision support design methodology	11
2 Requirements and specification of decision support functions	12
2.1 Decision support during a single frequency deviation event (USTRATH_1)	12
2.1.1 Functional requirements for the procurement of new BRC reserves after a frequency event (USTRATH_DSS_1)	12
2.1.2 Functional requirements for the BSC replacement of BRC deployed reserves (USTRATH_DSS_4).....	13
2.1.3 Functional requirements for the BESS energy restoration after a frequency deviation event (ENEA_DSS_1)	13
2.2 Decision support during two simultaneous frequency events (USTRATH_2)	14
2.2.1 Functional requirements to the response to a frequency event larger than the BRC reserves can handle (USTRATH_DSS_2)	14
2.2.2 Functional requirements for the response to an emergency request from a neighbouring cell for BRC support (USTRATH_DSS_3).....	14
2.2.3 Functional requirements for the response to a frequency event due to the loss of a tie-line (RSE_DSS_1).....	15
2.3 Decision support for transient stability preventive control (DTU_2)	15
2.3.1 Functional requirements for transient stability preventive control (DTU_DSS_1)	15
2.4 Decision support for management of inter-cell loop flows (DTU_4)	16
2.4.1 Requirements and functionality for management of inter-cell loop flows (SINTEF_DSS_1).....	16
2.5 Decision support for over/under voltage (TEC_2)	17
2.5.1 Functional requirements for the response to an over/under voltage event (INESC_P_DSS_1)	17
3 Decision support system design and implementation.....	18
3.1 Decision support during a single frequency deviation event (USTRATH_1)	18
3.1.1 Decision support system design overview for frequency control	18
3.1.2 Decision support for the procurement of new BRC reserves after a frequency event (USTRATH_DSS_1).....	18
3.1.3 Decision support for the BSC replacement of BRC deployed reserves (USTRATH_DSS_4).....	20
3.1.4 Decision support for BESS energy restoration after a frequency deviation event (ENEA_DSS_1).....	21
3.2 Decision support during a two frequency deviations event (USTRATH_2)	25

3.2.1	Decision support for the response to a frequency event larger than BRC reserves can handle (USTRATH_DSS_2)	25
3.2.2	Decision support for the response to an emergency request from a neighbouring cell for BRC support (USTRATH_DSS_3).....	26
3.2.3	Decision support for the response to a frequency event due to the loss of a tie-line (RSE_DSS_1)	26
3.3	Decision support system for transient stability preventive control (DTU_2)	30
3.3.1	Decision support for transient stability preventive control (DTU_DSS_1).....	30
3.4	Decision support system for management of inter-cell loop flows (DTU_4).....	33
3.4.1.	Decision support for management of inter-cell loop flows (SINTEF_DSS_1).....	33
3.5	Decision support system for over/under voltage (TEC_2)	37
3.5.1	Decision support for the response to an over/under voltage event NESC_P_DSS_1	137
4	Conclusions	41
5	References	42
6	Disclaimer	43

List of figures and tables

Figure 3-1: UDSS architecture	18
Figure 3-2: Cell diagram of USTRATH_DSS_1 case study	20
Figure 3-3: Flow-chart of the decisional logic for ENEA_DSS_1	22
Figure 3-4: Cell diagram of ENEA_DSS_1 case study	23
Figure 3-5: Example of network with the loss of a tie-line	27
Figure 3-6: RDSS architecture	28
Figure 3-7: WoC in N conditions	28
Figure 3-8: WoC in N-1 conditions and no violations	28
Figure 3-9: WoC in N-1 conditions and violations	29
Figure 3-10: WoC in N-1 conditions and change of set-points	29
Figure 3-11: Network conditions after the fault clearing	30
Figure 3-12: Flowchart of the transient stability preventive control approach	31
Figure 3-13: New England test system with indication of associated cost functions	32
Figure 3-14: CCTs and active power set-points for initial condition and after successful dispatch	33
Figure 3-15: Topology of the Pan-European Single Reference Power System	35
Figure 3-16: Initial load flow (a), load flow after power reduction in SG1.10 (b) and unscheduled power flow after power reduction in SG1.1 (c)	36
Figure 3-17: Result of updated OPF in Cell 1 and 2 (a), actual load flow after updated OPF (b) and unscheduled power flow after updated OPF (c)	37
Figure 3-18: Voltage Control Algorithm	39
Figure 3-19: - Portuguese MV Network	39
Figure 3-20: Voltage values in some nodes of the considered Portuguese network	40
Figure 3-21: Total losses of the considered Portuguese distribution system	40
Table 1-1: Subset of the scenarios defined in ELECTRA D8.1 and adopted in D8.2	11
Table 3-1: USTRATH_DSS_1 case study result	20
Table 3-2: USTRATH_DSS_4 case study result	21
Table 3-3: BESS MOC in ENEA_DSS_1	23
Table 3-4: BESS MOD in ENEA_DSS_1	24
Table 3-5: Information provided to the Cell Operators in ENEA_DSS_1	24
Table 3-6: USTRATH_DSS_2 case study result	26
Table 3-7: Comparison of measured values and results from power flow on nodes nearby SG1.10	36

1. Introduction and methodology

1.1 Decision support for human operators within a Web of Cells

This report discusses the need for Decision Support Systems (DSS) for operators of a network cell within the future Web of Cells (WoC) architecture developed within the ELECTRA IRP [1]. The aim is to demonstrate specific scenarios where DSS are particularly useful, due to the complexity of the control options available to such an operator. The main questions addressed in this report are:

- Which decisions are particularly critical for the cell operator?
- What are some of the available control actions that could be taken?
- How can such actions be prioritised and compared against each other?
- How can alternative plans be presented to the operator, and how can they reprioritise the control actions?

The work is heavily based on the visualisation scenarios developed in previous activities and reported in D8.1 [2]. The present document considers specific critical scenarios in detail, from initiating incident through to scenario resolution, and proposes new analytics and visualisations to assist the operator in resolving the situation. The aim is to focus in detail on one or more decision points within these scenarios, and explore the questions above.

As outlined in D8.1, “the roles and activities in the future control centres will evolve with respect to the manual switching, dispatching and restoration functions currently active. The control centre operators will supervise on the power system and intervene - when necessary - thanks to the maturation and wide scale deployment of flexible controls.” Part of the decision support research is to help characterise what the role of an “operator” will be in the future. In the first instance, we consider someone with responsibility for the cell. However, the solutions could be applied to provide decision support for those overseeing the full Web of Cells, where additional high level supervisory support could be added to the visualisations and automation provide per cell.

A decision point is characterised as being a situation where there are various actions that could be taken, and it is not a trivial task to prioritise which is better or worse than others. One example would be where there is a need to procure balancing support from a neighbouring cell, but multiple neighbours can provide sufficient spare resources. The operator must decide whether to take support from a single neighbour, some support from each neighbour, or whether to manage local load, and how much in each case. There are various metrics which can help to prioritise the choices, such as speed of response of the resource, and tie-line constraints. In this context, the DSS can construct a plan to restore cell balance, which comprises a sequence of actions (such as requests to neighbours and local signals) to achieve the plan.

The focus is on an environment where the operator will fully delegate decisions to the DSS, and be informed of the status and stability of the network. It is envisaged that there will be a mode whereby the operator can take manual decisions at any point, without necessarily having to follow the plan(s) proposed by the DSS. However, for time-critical decisions where an action must be taken within a certain window the fully automated mode of the DSS will be able to independently implement the highest priority plan. A key aspect of the research is determining the decision support to drive the appropriate balance of interaction between an operator and the automated control system.

The DSS is conceived to be a powerful advance on typical control approaches through its abilities for gathering data from neighbouring cells, its intelligent reasoning, and its proactive operation.

1.2 ELECTRA Control Room Scenarios

A number of control room scenarios have been developed in which operators must have visibility of and take action to mitigate critical issues. A subset of these scenarios were taken forward to detailed study, and those selected allowed the best combination of novel decision making and reasoning functionality linked to complex issues that would need to be handled by the control room. These covered transient stability, inter-cell loop flows, frequency management and voltage control. The table below briefly summarises these detailed scenarios, as the starting point for examining decision support requirements.

Table 1-1: Subset of the scenarios defined in ELECTRA D8.1 and adopted in D8.2

Scenario name	Brief description
Transient stability preventive control (DTU_2)	Initiating incident: Insufficient transient stability margin Critical Clearing Time (CCT) Potential actions: Dispatch of local generators; request for neighbouring cell support
Inter-cell loop flows (DTU_4)	Initiating incident: Power over a tie-line exceeds/undershoots its contracted value Potential actions: Control loads/generators to manage power flow; troubleshoot the cause; take action to resolve the cause
Proactive operation of Post-Primary Voltage Control (PPVC) (TEC_2)	Initiating incident: Timed repeated trigger Potential actions: Detect voltage deviations from forecast, activate PPVC reserves
Single frequency deviation event (USTRATH_1)	Initiating incident: Loss of generation/increase in load Potential actions: Procurement of replacement reserves
Two frequency deviation events (USTRATH_2)	Initiating incident: Two losses of generation/increases in load happening almost simultaneously. Loss of a tie-line. Potential actions: Procurement of sufficient reserves

1.3 Decision support design methodology

The methodology for developing decision support demonstrators was as follows:

1. Develop the requirements and functional specification for decision support.
 - a. Select one of the scenarios defined in D8.1 (as above) for close study.
 - b. Identify one or more decision points within the scenario sequence diagrams. For each decision point, identify:
 - i. What decision does the operator have to make?
 - ii. What are some of the alternative actions that could be taken?
 - iii. What is the intended/successful outcome?
 - c. For each decision point identified above, determine what metrics are important for selecting between alternative actions to resolve the decision (i.e. what makes one plan “better” than another?). Consider how to select the most suitable metrics.

2. Based on the functional specification, design the decision support system.
 - a. Select an appropriate tool or approach for implementing the DSS (e.g. constraint satisfaction, optimization methods, case based reasoning).
 - b. Implement and test “off-line”, i.e. with historical, simulated, or synthetic data.

2 Requirements and specification of decision support functions

The primary difference between the DSS functions in this work, compared to other research, is the WoC context. The decision support needs to accommodate the automation and interactions required for the operation of a web of cells.

This section presents the outcomes of step 1 of the methodology presented in section 1.3. For each of the control room scenarios selected for detailed study, one or more decision points have been identified. These are given codes for ease of reference (such as USTRATH_DSS_1). Each decision point is analysed for its required functionalities, which provide a specification of the decision support systems implemented in Chapter 3.

2.1 Decision support during a single frequency deviation event (USTRATH_1)

The scenario USTRATH_1 involves a sudden change in system balance, which causes the frequency to deviate outside of operational limits. It is assumed that the deviation can be mitigated by the Balance Restoration Control (BRC) reserves previously procured during the planning phase of operation, and therefore the WoC control systems will automatically return the frequency within operational limits.

This scenario has three key decision points where the operator can be involved:

- Procurement of new BRC reserves after a frequency event;
- Balance Steering Control (BSC) replacement of BRC deployed reserves;
- Battery Energy Storage Systems (BESS) energy restoration after a frequency deviation event.

2.1.1 Functional requirements for the procurement of new BRC reserves after a frequency event (USTRATH_DSS_1)

After Frequency Containment Control (FCC) has operated to contain the frequency deviation and BRC has operated to restore the frequency, the cell may need to replenish the BRC reserves in case of a future event. The WoC concept includes a periodic planning phase, where neighbouring cells can negotiate to provide each other support in case of events during real time operation. If the USTRATH_1 scenario occurs very shortly after the previous planning phase, the cell operator may wish to procure new reserves to mitigate against a further loss of generation. However, if there is a very short period before the next scheduled planning phase, the operator may prefer to take the risk of operating with depleted reserves, instead of procuring further (potentially costly) reserves.

In this case, the decision support system aims to address the question: what reserve should be procured for BRC? Some alternative actions that could be taken include procuring no reserves, slow acting reserves (e.g. combined cycle gas turbines - CCGT), fast acting reserves (e.g. Hydro), or demand response. The cost will be a factor in the prioritisation of resources, but not the primary driver (for example, CCGT may be cheaper than Hydro, but a fast response is needed to restore

frequency). A successful outcome would be when the operator is satisfied that sufficient reserves have been procured for BRC for the remainder of the real time operation period.

The metrics that are taken into account when prioritising these actions are: time remaining until next planning phase, available reserves within its own cell and neighbouring cells with capacity, speed of response, cost of reserves and location of reserves (own and neighbour resources may be preferable to neighbour-of-neighbour resources), and tie-line operation margin.

2.1.2 Functional requirements for the BSC replacement of BRC deployed reserves (USTRATH_DSS_4)

When BRC has completed its operation to restore frequency within limits, BSC takes over to optimise the mix of generation and demand management. As the reserves used at the BRC stage are fast acting and therefore expensive, the target of BSC is to replace these reserves with more economical choices. But the most economical solution is not necessarily the best solution.

In this case, the decision support system aims to address the question: how to replace the deployed reserves with “better” sources? Some alternative actions that could be taken include making no changes to the generation/load profile, or substituting fast-acting generation with slower start up generation. A successful outcome would be any expensive BRC deployed reserves being replaced with less expensive options.

The metrics that are taken into account when prioritising these actions are: available reserves from own cell and neighbouring cells with capacity, speed of response, cost and location of resources and tie-line operation margin.

2.1.3 Functional requirements for the BESS energy restoration after a frequency deviation event (ENEA_DSS_1)

When a sudden system imbalance occurs with a divergence of the frequency from the nominal value, BESS within the cell (one or more) can be used to provide the energy required for the restoring process. A “safety energy band” is defined for each BESS system within the cell in order to ensure the necessary power for the stability control.

After reaching the stability, the BRC brings the State of Charge (SOC) of the BESS into their safety energy range by slow charging or discharging operations. In particular, the cell operator must conveniently set the charging/discharging currents to bring SOC more quickly again within their safety energy range. However, the cell operator has to ensure currents are not too high in order to preserve the stability of the whole system, through an automated control system. Therefore, the cell operator requires DSS support to decide on the following issues:

- How much "energy restoration time" is necessary for each BESS to return within the safety energy range?
- To evaluate the energy restoration time, the DSS must know the SOC for each BESS. Then, the cell operator can decide to modify the charging/discharging current, by choosing the appropriate value.
- Which are the alternative actions that could be taken to bring the SOC of the BESS back in their safety energy range?

If the cell does not have spare capacity, the DSS can consider using the support of the neighbouring cells. The metrics which could take into account when prioritizing these actions are the cost of the reserves and the location of resources.

2.2 Decision support during two simultaneous frequency events (USTRATH_2)

The scenario USTRATH_2 involves two almost simultaneous events which disturb the system balance. It is assumed that the combined effect of the events is more significant than the BRC reserves can mitigate. An alternative abnormal event that may imply the loss of the system stability is the loss of a tie-line. Therefore, further actions must be taken to procure emergency support and return the frequency within the operational margin.

This scenario has three key decision points where the operator can be involved:

- Response to a frequency event larger than the BRC reserves can handle;
- Response to an emergency request from a neighbouring cell for BRC support;
- Response to a frequency event due to the loss of a tie-line.

2.2.1 Functional requirements to the response to a frequency event larger than the BRC reserves can handle (USTRATH_DSS_2)

During scenario USTRATH_2, a combination of FCC and load shedding contains the frequency, then BRC reserves are deployed, but the frequency does not return within operational limits. At this point, the problem cell must contact its local devices and neighbouring cells to ask for how much support can be offered to mitigate this emergency situation.

The decision support system aims to address the question: how can frequency be restored within operational limits? Once the neighbouring cells respond with their available capacity, some alternative actions that could be taken include requesting that some or all of this support is deployed. A successful outcome is a balance being restored to the system.

The metrics that are taken into account when prioritising the use of resources are: available reserves from own cell and neighbouring cells with speed of response, capacity and costs and tie-line operation limits.

2.2.2 Functional requirements for the response to an emergency request from a neighbouring cell for BRC support (USTRATH_DSS_3)

This decision point is complementary to USTRATH_DSS_2, in that the neighbouring cell to the problem cell must also make a decision about how much support can be committed to their neighbour.

The decision support system aims to address the question: how much capacity should be offered to the neighbour in this emergency situation? If the cell has a spare capacity which is uncommitted as reserves, it should generally be offered. However, if this cell (cell A) has committed to offer BRC support to a third party cell (cell C), should it offer those reserves to its neighbour in immediate need (cell B: the cell with the problem)? Does it depend on how soon the next planning phase begins? That is, the chances of cell A needing to supply BRC support to cell C will be lower if this real time operation phase finishes in 10 minutes, compared to it finishing in 5 hours. The amount of BRC reserves offered to cell B will vary based on factors such as this. A successful outcome would be where sufficient reserves are offered to the neighbours without compromising this cell's commitments.

The metrics that are taken into account when prioritizing the options are: time remaining before the next planning phase, the capacity of uncommitted reserves, the capacity of committed reserves and the tie-line operation margins.

2.2.3 Functional requirements for the response to a frequency event due to the loss of a tie-line (RSE_DSS_1)

A situation that may cause relevant frequency deviations is the loss of a tie-line transferring power. In fact, the loss of a tie-line implies an unbalance between load and generation, which causes a frequency oscillation.

Even if the FCC intervenes to stop the frequency deviation, at the end of the intervention the frequency is not at its rated value. Hence, the “Balance Restoration Reserve” is activated through the BRC to restore the rated frequency¹.

In this case, the decision support process should identify what flexibilities involve to maintain the system balance and the rated frequency. In this frame, the control room operator has different levers to act on, such as:

- network reconfiguration;
- change the load and/or generation profiles;
- change the power exchanged with neighbouring cells.

In order to support the control room operator in the choice of the best solution, the following metrics should be taken into account:

- available reserve from flexibilities (e.g. storage, distributed generation, controllable loads etc.);
- support available from the neighbouring cells;
- power flows on the tie-lines and the related information (e.g. maximum transfer capacity);
- actual network situation (i.e. bus voltages, line currents etc.).

As in the previous situation, the intended outcome is to restore frequency to its rated value. Finally, if the perturbation can be managed at the local level, the decision support process acts only on local information otherwise, the influence will also be on neighbouring cells ones.

2.3 Decision support for transient stability preventive control (DTU_2)

It is important to operate the power system with sufficient transient stability margins in terms of Critical Clearing Time (CCT). Therefore, the CCT for severe contingencies, e.g. three-phase fault, has to be assessed online. Preventive actions to re-establish a predefined stability level need to be taken if insufficient transient stability margins are detected. Several preventive actions could be taken, but the most effective one is to re-dispatch generators. The predefined stability margin is expressed as the minimum CCT which is allowed for a specific contingency.

2.3.1 Functional requirements for transient stability preventive control (DTU_DSS_1)

The decision support system aims to answer the question: How can the generators be dispatched economically to re-establish pre-defined stability margins? Technical constraints, such as active/reactive power capabilities, maximum line flows and voltage levels must be satisfied. As the control is from a preventive nature, the dispatch of the generators must be done in the most economical way in order to minimize the additional costs. The metrics used in the approach are the CCT and costs of the re-dispatch.

The decision support system needs information about the current system state, e.g. generation schedule, breaker status and operation of capacitor banks. Global information is needed to an extent so that it is possible to represent the external power system as an equivalent.

¹ It has to be noted that when the BRC is activated, only the resources of the considered cell(s) are involved.

The decision support system provides the control room operator a dispatch suggestion and the associated additional costs of the proposed action. The control room operator has to evaluate and approve the suggested dispatch. If necessary, the control room operator can interact with the decision support system by imposing additional constraints, e.g. that the active power set-point of certain generators is fixed and, thus, these generators cannot be re-dispatched. That means the re-dispatch assessment is re-run taking into account the additional introduced constraints and a new re-dispatch proposal are calculated.

2.4 Decision support for management of inter-cell loop flows (DTU_4)

Loop flows are a normal occurrence in the power system. In a meshed grid, an Optimal Power Flow (OPF) will give results that cause some power to flow to neighbouring cells both through the direct connection, but also through multiple other cells that provide an alternative path. However, when a loop flow occurs outside specified power flows, this is an indication that the system does not behave as suggested by the OPF. There could be several reasons for this deviation, such as sudden changes in network configuration (e.g. loss of a transmission line), but also more subtle causes perhaps will not always be detected, which include:

- A generator or other sources of active and reactive power are unable to deliver the contracted power due to limitations in the source (e.g. apparent power limitation in converters and stability limits in synchronous generators). The entire source could also be malfunctioning, or is unable to accept new set points due to faults in the communication system.
- Faulty measurement data: The measured power through a line or from a source differs from the actual power flow, causing regulating units to behave suboptimally.
- Uncoordinated voltage set points between cells: If set points within a cell are not communicated to the neighbouring cell, this will cause an unscheduled reactive power flow across tie-lines with varying voltage set points on each side.

2.4.1 Requirements and functionality for management of inter-cell loop flows (SINTEF_DSS_1)

The purpose of this decision support system is threefold: to analyse the cause of the unscheduled loop flow; to mitigate the cause of the unscheduled loop flow; and, if necessary, to perform mitigation measures on possible negative consequences from the loop flow (i.e. load shedding or activation of additional generators).

To analyse the cause of the unscheduled loop flow, a useful tool could be a heat mapping of contracted vs real power flow in the two cells bordering the tie-line with the unscheduled loop flows. Green colours indicate small or no deviation ($\pm 10\%$ of rated capacity), and red large deviations ($>10\%$ of rated capacity). As more tie-lines have deviating values, further cells should be included. An important aspect of such tool is that it should be easy and intuitive to use when analysing the root cause. If some areas show high variation between contracted and real values, the sources in this area can be analysed to determine if they:

- Provide contracted values: If not, a check can be performed to see that they are able to receive a new set point. If not, new limitations on the generator should be provided to the OPF, which as soon as possible should perform a recalculation to update all set points in the cell. Some part of this functionality could be integrated into the OPF as an automated check.

- Measure the correct values: This can be controlled by analysing nearby measurements to look for inconsistencies. This should result in a work order to inspect measurement equipment on relevant locations.
- Have large changes in voltage set-points in each end of a tie line: These should be changed to match, and a new OPF carried out and implemented.

If no causes for the loop flow is found, or could be mitigated, and the loop flow is causing constraint violations etc, alternatives such as load shedding or starting of additional generators should be performed.

2.5 Decision support for over/under voltage (TEC_2)

The voltage control developed will be a centralized control. This centralized control will be placed at a Cell Operator control room and will send set-points to different kinds of distributed energy resources (DER), like controllable loads, microgeneration, generation or storage devices. One of the main objectives of this voltage control is to proactively mitigate over/under voltages, restoring the voltage levels to nominal values.

2.5.1 Functional requirements for the response to an over/under voltage event (INESC_P_DSS_1)

One of the assumptions of ELECTRA is the large-scale integration of DER, which may bring challenges to the operation of cells. One of the main challenges of this integration is related to voltage problems because resources like PV or wind generation may cause sudden voltage variations.

When a violation of the voltage limits is detected, flexible resources can be mobilized to mitigate the problem. A centralized cell controller will periodically run an OPF algorithm and send set points to the resources that are available to contribute to the voltage problem mitigation. The cell operator will be able to accept or reject the first solution provided by the OPF. In case the solution is rejected, a new OPF will be run but now only considering the flexible resources selected by the cell operator to solve the voltage problem.

The decision support platform that will be developed for voltage control will include two modes of operation: proactive and corrective mode. The proactive mode will calculate set points to be used by the resources in the next time frame of 15 minutes, if a voltage problem is envisaged. The corrective scenario will be used when an unexpected voltage problem occurs.

3 Decision support system design and implementation

3.1 Decision support during a single frequency deviation event (USTRATH_1)

3.1.1 Decision support system design overview for frequency control

The main focus of the USTRATH Decision Support System (UDSS) is to develop an intelligent system that gathers cell information and provides the knowledge and optimisation tools to support proactive decision making. The proposed UDSS has knowledge about decision points and what data is required for each decision point. Then, the UDSS can provide decision option(s) based on its knowledge or optimised solutions by interacting with its optimisation tool. The selected optimisation method is constraint programming, which is applied to a Constraint Satisfaction Problem (CSP) [3]. A CSP needs a value selected from a given finite domain to be assigned to each variable in the problem so that all constraints are met. The UDSS architecture is illustrated in Figure 3.1. The details of the UDSS architecture are described below.

The UDSS is composed of a Knowledge Base (KB) and a CSP solver. The KB contains the knowledge that determines when it needs to trigger the decision making. This is based on the cell information received. If the network conditions mean a decision is required, it will request the required data from the Supervisory Control and Data Acquisition (SCADA) for this decision point such as the available reserves from its own and neighbouring cells along with their speed of response, cost and capacity. After that, if the KB needs the CSP solver to provide the ranked solutions it will add the relevant constraints, variables and domains into the CSP solver and trigger it to search potential solutions for this decision point. For some cases, the KB has the knowledge to directly provide the decision plan based on its knowledge without using the CSP solver, such as USTRATH_DSS_3 (see 3.2.2 for details). The CSP solver searches for solutions by finding complete assignments of domain values to variables that meet all the constraints. For many problems, there may be more than one set of variable assignments that satisfy all declared constraints. In such cases, the CSP solver can be configured to return either a user-defined number of solutions in a best-first manner or to search for all possible solutions.

The following sections explain how different decision points in two frequency scenarios can be modelled as a CSP.

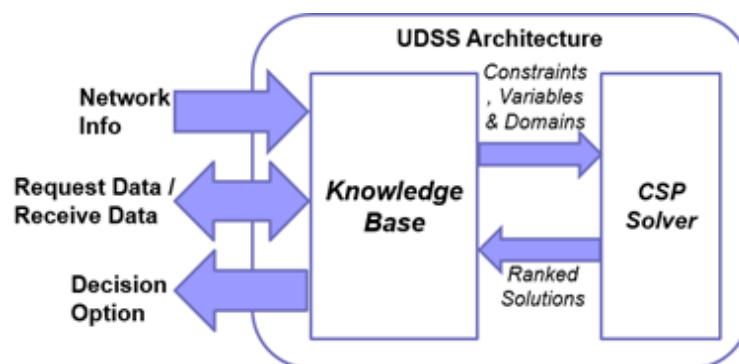

Figure 3-1: UDSS architecture

3.1.2 Decision support for the procurement of new BRC reserves after a frequency event (USTRATH_DSS_1)

In this case, the decision support function aims to procure new reserves to mitigate against a further loss of generation after the frequency returns to the operational limits. Therefore, the

decision support system needs to determine which reserve should be procured for BRC and a fast response is required to restore the frequency. The metrics that are taken into account when prioritising the actions are: available reserves from own cell and neighbouring cells with speed of response, cost, the capacity of each reserve and tie-line operation limits between cells.

To model this decision point as a CSP, it must be expressed as a set of *variables* with finite discrete *domains* and a set of *constraints*. The *variables* of the CSP are the reserves of each cell, $X = RSV_1, \dots, RSV_n$. Associated with each variable is a *domain* of discrete values, which are the control signals that can be sent to the reserves, e.g. $RSV_1 = \{\text{control}_1, \dots, \text{control}_n\}$. Each reserve is given a number of control bandings, e.g. 80% of rated output, 70% of rated output, 60% of rated output etc. The control bandings become the reserve variable's domain, e.g. $\{1, 0.8, 0.6, 0.4, 0.2, 0\}$, where 1 represents reserve operation with rated output and 0 represents the 0 output state of the reserve. In addition to *variables* and their domains, the constraints on the solution must be modelled. For this decision point, it needs to procure the new BRC reserves as quickly as possible in case a further frequency deviation happens before the next scheduled planning phase. Following constraints have been defined:

Reserve constraints: any potential solution in the form of control signals sent to reserves must fulfil the required BRC reserves.

Time constraints: the total time to procure new BRC reserves must be complete before the next planning phase for any possible solution.

Tie-line operation constraints: the reserve operation between cells must be within tie-line operation limits for any given solution, i.e. a determined solution will not result in a thermal overload of tie-line operation limits between cells.

Solution prioritisation constraints: for a given situation, there may be many sets of options, which meet the constraints above. As a result, it needs to sort the solutions to find the solution that is determined to be better than the others. As this decision point needs to procure reserves as quickly as possible, the quicker solution will be best. If some solutions have the same operation time, it will compare total cost and determine which one is cheapest.

3.1.2.1 USTRATH_DSS_1 case study

The case study for this decision point comprises three cells, which are portrayed in Figure 3.2. It is assumed that each cell has one generator and one reserve. The amount of each reserve is: $RSV_1 = 50MW, RSV_2 = 90MW, RSV_3 = 200MW$. The Speed Of Response (SOR) for each reserve is: $SOR_1 = 35MW/Min, SOR_2 = 45MW/Min, SOR_3 = 150MW/Min$. The cost function for each reserve uses the polynomial function, i.e. $C_1 = ax_1^2 + bx_1 + c$. In addition, the status of reserve takes into consideration the calculation of the cost for the required reserve. This is because it is less expensive to generate power from a warm generator than a cold generator. The tie-line operation limits between Cell1 and Cell2, and Cell2 and Cell3 is **50 MW** and **150 MW** respectively. From the perspective of CSP, each reserve variable has the following domain (control bandings), $\{1, 0.9, 0.8, 0.7, 0.6, 0.5, 0.4, 0.3, 0.2, 0.1, 0\}$. For this case study, we assume the frequency event occurred within Cell2 (red colour), which needs to procure **100 MW** BRC reserves. The time remaining until the next planning phase in this case study is **30 minutes**. The result of this case study is shown in Table 3.2 which lists the top 3 decision options and noted that reserve initial status in each cell is presented at the bottom of the table.

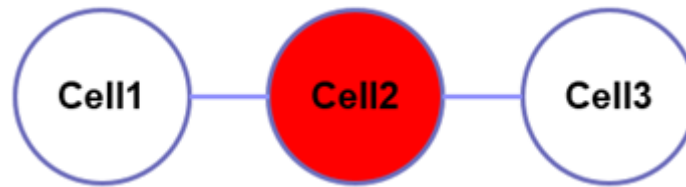

Figure 3-2: Cell diagram of USTRATH_DSS_1 case study

Table 3-1: USTRATH_DSS_1 case study result

Solution	Cell 1 (MW)	Cell 2 (MW)	Cell 3 (MW)	Total Time(min)	Total Cost (£)
1	0	0	100	0.667	8105
2	20	0	80	12.10	5425
3	40	0	60	12.54	3785

RSV_1 : OFF; RSV_2 : ON; RSV_3 : ON

As the purpose of this decision point is to procure the new BRC reserves as quickly as possible to mitigate further loss of generation, the first option is to procure all 100MW reserves from Cell3. This is the quickest option (less than a minute). The reason to take all reserves from Cell3 is that it is the fastest acting between these three reserves. However, the fast acting solution is more expensive by comparing with other options.

3.1.3 Decision support for the BSC replacement of BRC deployed reserves (USTRATH_DSS_4)

This case is the replacement of the deployed BRC reserves with more economical choices. As a result, the decision support system needs to replace the deployed BRC reserves with less expensive options. The metrics that are taken into account for this decision point are: available reserves from own cell and neighbouring cells with speed of response, the cost of reserves, the capacity of each reserve and tie-line operation limits between cells.

To model this decision point as a CSP, it utilises the same *variables* and *domains* as USTRATH_DSS_1. Hence, the *variables* of the CSP are the reserves of the cells, $X = RSV_1, \dots, RSV_n$. The *domain* of each *variable* is the control banding, e.g. $RSV_1 = \{control_1, \dots, control_n\}$ as described in the USTRATH_DSS_1 CSP model. The *constraints* of the CSP are the same as applied for USTRATH_DSS_1: **reserve constraints**, **time constraints**, **tie-line operation constraints** and **solution prioritization constraints**. However, the approach to sort the potential solutions is different within the **solution prioritization constraints**. As the target of this decision point is to provide more economical solutions to replace the deployed BRC reserves, the cheaper solution will be better. If some solutions have the same total cost, the quicker solution will be selected as the best.

3.1.3.1 USTRATH_DSS_4 case study

The USTRATH_DSS_4 case study utilises the same cell network (the three-cell network as shown in Figure 3.2) as the USTRATH_DSS_1 case study. Each cell has one reserve and capacity amount, cost, and speed of response and these are the same as in the USTRATH_DSS_1 case study. Moreover, the *domain* for the reserve *variable* is the same, $\{1, 0.9, 0.8, 0.7, 0.6, 0.5, 0.4, 0.3, 0.2, 0.1, 0\}$. As discussed above, the *constraints* for this CSP are the same as the USTRATH_DSS_1 CSP model. It assumes the Cell2 needs to replace **100 MW** reserves within **30**

minutes before the next planning phase in this case study. The tie-line operation limits between the cells are the same as the USTRATH_DSS_1 case study. The result of USTRATH_DSS_4 is presented in Table 3.3 which shows the top 3 options reserve initial status in each cell is presented at the bottom of the table.

Table 3-2: USTRATH_DSS_4 case study result

Solution	Cell 1 (MW)	Cell 2 (MW)	Cell 3 (MW)	Total Time(min)	Total Cost (£)
1	35	45	20	13.13	2252.5
2	15	45	40	12.69	2712.5
3	40	0	60	12.54	3785

RSV_1 : OFF; RSV_2 : ON; RSV_3 : ON

From the case study result, the first option is the cheapest option (total cost: 2525.5) that takes 35MW from Cell1, 45MW from Cell2 and 20MW from Cell3. However, the first option will take more time to complete the operation by comparison with the other options.

3.1.4 Decision support for BESS energy restoration after a frequency deviation event (ENEA_DSS_1)

In a WoC architecture, the role of the dynamic elements within the cell will increase even more to guarantee the cell stability and thus the whole network stability. From this point of view, it is crucial that the BESS involved in the cell stability process are in a state of charge within the safety energy band in order to ensure the necessary power for the stability control.

In the USTRATH_1 scenario (single frequency deviation event), the cell stability is obtained after a single frequency deviation by means of BRC, where the SOC state of all the BESS involved in the stability control will be verified within the cell, and the safety energy range will be restored as well.

The cell operator is in charge of the decision to select the BESS within the cell for the energy storage restoration, if necessary. To support the cell operator's decision, several information is needed:

- Safety energy band recovery time;
- Cost of the reserves;
- BESS position;
- Information about the BESS (the type of BESS, capacity, SOC).

By following this approach, the cell operator will be able to decide which BESS to control for the energy band restoration or whether it should make no decision.

The logical scheme of the decision logic system is shown in Figure 3.3 below.

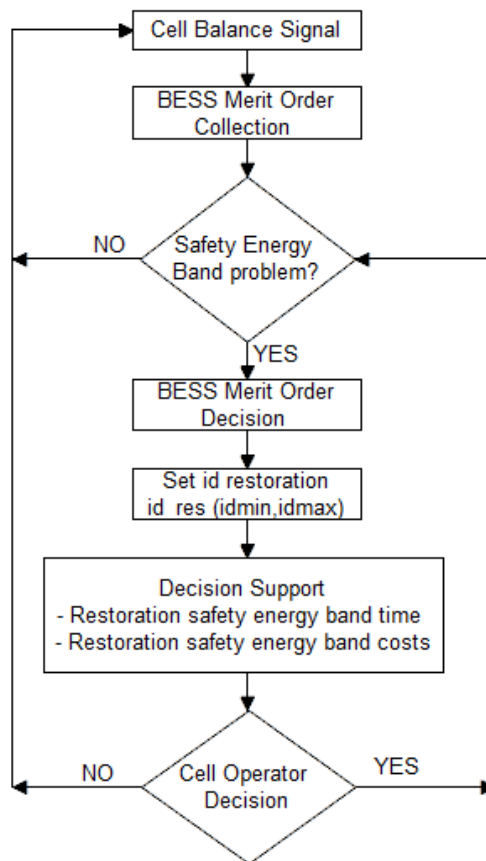

Figure 3-3: Flow-chart of the decisional logic for ENEA_DSS_1

To avoid the interference with BRC control, the safety energy range restoration is carried out only after a BRC control caused by, for example, a single frequency deviation event.

Once the stable state of the cell is verified, a BESS Merit Order Collection (MOC) is created. The BESS MOC is a matrix of information related to BESS devices within the cell, such as BESS device type, SOC state, safety energy band specifics. Moreover, some other information could be added about the BESS location within the cell and energy band restoration costs.

Starting from BESS MOC information, a BESS Merit Order Decision (MOD) matrix is created. The BESS MOD is a sub set of BESS MOC containing only the energy storage systems actually involved in the stability process and a SOC outside of the safety energy band.

A restoration current is set (id_res). This current will be the charge/discharge current for the safety energy band restoration and could be changed by the cell operator between a maximum and minimum value, always ensuring the cell stability.

Exploiting the above information, the DSS estimates the charge/discharge times required for the safety energy range restoration for all the energy storage system listed in BESS MOD and, optionally, evaluates costs as well.

Thus, cell operator could be able to choose which BESS to control within the cell in order to restore its safety energy band or just do nothing if he foresees that the next single frequency deviation event will not occur in the future.

3.1.4.1 ENEA_DSS_1 case study

The ENEA_DSS_1 case study is based on a generic WoC architecture shown in Figure 3.4.

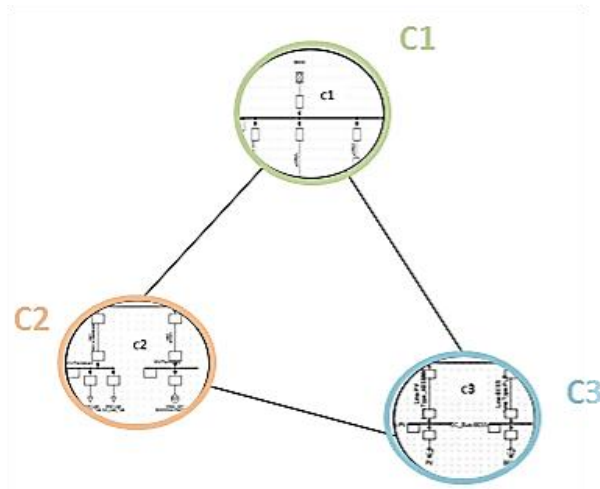

Figure 3-4: Cell diagram of ENEA_DSS_1 case study

In each cell, there can be one or more energy storage systems to support the frequency restoration during an imbalance event. For simplicity, it is assumed that there is one energy storage system for each cell. Moreover, a (SOC_{max} - SOC_{min}) band named Energy Safety Band (ESB) is defined for each energy storage system. The ESB definition is important to guarantee the necessary spare power for the cell frequency restoration.

In a stable grid condition, we assume that each SOC is always within its own ESB. In case of an imbalance event, it is possible that the SOC value can escape the ESB to support the frequency restoration. After the frequency restoration, the ENEA_DSS_1 supports the cell operator for the ESB restoration. ENEA_DSS_1 makes available to the cell operator two tables, which are the BESS MOC and the BESS MOD. Moreover, the ENEA_DSS_1 sets a low electrical current within a $i_{d_{max}}$ and $i_{d_{min}}$, for the safety energy band restoration. The BESS MOC table is a list of all energy storage system within the grid divided by cell as shown in Table 3-3.

Table 3-3: BESS MOC in ENEA_DSS_1

BESS CELL	Type	Energy safety band [Min-Max]	SOC _{max}	SOC _{min}	SOC real time value	Location and cost (in case)
CELL1	-	[20% - 80%]	90%	10%	18%	-
CELL2	-	[20% - 80%]	90%	10%	30%	-
CELL3	-	[20% - 80%]	90%	10%	15%	-

The BESS MOD table is a subset of BESS MOC and represents, for each cell, the energy storage system with the SOC value escaped its own safety energy band. In our case study, this is assumed to be true for CELL1 and CELL3 as shown in Table 3.5.

Table 3-4: BESS MOD in ENEA_DSS_1

BESS CELL	ESB escape
CELL1	YES
CELL2	NO
CELL3	YES

At the end, the cell operator can modify the electrical current value for the ESB restoration between id_{max} and id_{min} , thereby guaranteeing the frequency stability.

Starting from this premise, the ENEA_DSS_1 evaluates the necessary time for the ESB restoration related to the energy storage system in CELL1 and CELL3, and makes available to the operator the information shown in Table 3-5.

Table 3-5: Information provided to the Cell Operators in ENEA_DSS_1

ESB Time restoration CELL	Time(min)	Necessary Action (Charge/discharge)	ESS state (Charge/discharge)
CELL1	$f(\text{Type, SOC_real time value})^2$	Charge	Charge
CELL3	$f(\text{Type, SOC_real time value})$	Charge	Discharge

During the restoration phase, the current has to be low in order to guarantee the system stability. This means that the ESB restoration process could require a long time (depending on the SOC value), and during this phase, the BESS will be busy due to its involvement in the restoration process.

Thus, it is important to know what type of action (charging/discharging) is necessary for the ESB restoration, as well as the actual state of the BESS in each cell.

In this case study, for example, to restore the ESB in CELL1, a charge action of the BESS is necessary, but this cell is already in charge mode, thus the operator will not undertake any action.

On the other hand, as shown in Table 3.6, in CELL3 a charge action for ESB restoration is necessary, while the BESS state is in discharge mode. In this case, cell operator can decide to put the BESS in CELL3 in charge mode in order to restore the ESB and chose the electrical current,

² The energy restoration time for charging/discharging process is linked to the battery type, the battery capacity and actual SOC value. For a fully charged battery, the discharging time can be defined based on Peukert's law [4]. Conversely, for a fully discharged battery, the charging time can be defined through practical formulas experimentally validated. Starting from the actual SOC value, it is possible to determine the time energy restoration for the charging and discharging process, based on references above.

between id_{max} and id_{min} , to minimize the restoration time (Time2) or just do nothing if he foresees the next single frequency deviation event will not occur in the future.

3.2 Decision support during a two frequency deviations event (USTRATH_2)

The scenario USTRATH_2 considers the extreme situation when two frequency events happen within one cell. Three key decision points occur where the operator may be involved and requires emergency support in order to return the frequency back to operational limits. The details of the design of these three decision support points are described below.

3.2.1 Decision support for the response to a frequency event larger than BRC reserves can handle (USTRATH_DSS_2)

The USTRATH_DSS_2 design, based around the proposed UDSS architecture mentioned above in section 3.1.1, are detailed below.

After the second frequency event occurs, the combined effect of the event is more significant than the BRC reserves can mitigate. The problem cell needs to contact the own cell and neighbouring cells about how much support can be provided to return the frequency to within operational limits. The metrics that are taken into account for prioritising the options are: available reserves from own cell and neighbouring cells with speed of response, cost, the capacity of each reserve and tie-line operation limits between cells.

To model this decision point as a CSP, we select available reserves from each cell as *variables*, $X = RSV_1, \dots, RSV_n$. The domain of each variable is the control bandings, $RSV_1 = \{control_1, \dots, control_n\}$. The constraints considered for this decision point are the same as the USTRATH_DSS_1, which are **reserve constraints**, **time constraints**, **tie-line operation constraints** and **solution prioritization constraints**. Since this decision point is to deal with an emergency situation, the decision support needs the support from the local cell and neighbouring cells as quickly as possible. The **solution prioritization constraints** utilized in this case search for the quicker solutions from the potential solutions.

3.2.1.1 USTRATH_DSS_2 case study

The case study applies the same scenario as the USTRATH_DSS_1 case study. Therefore, the capacity amount, speed of response and cost of reserves are the same as discussed in the USTRATH_DSS_1 case study. Moreover, the *variable*, *domain*, and *constraints* are the same for the CSP in this case study. It assumes the two frequency event happened within Cell2, which needs **150MW** reserves to return the frequency back to operational limits before the next planning phase in **30 minutes**. Furthermore, the tie-line operation limits between the cells are the same as the USTRATH_DSS_1 case study. The USTRATH_DSS_4 case study result is depicted in Table 3-6 with the top 3 options presented reserve initial status in each cell is presented at the bottom of the table.

Table 3-6: USTRATH_DSS_2 case study result

Solution	Cell 1 (MW)	Cell 2 (MW)	Cell 3 (MW)	Total Time(min)	Total Cost (£)
1	0	90	60	2.4	7895
2	10	0	140	12.22	15885
3	30	0	120	12.65	12125

RSV_1 : OFF; RSV_2 : ON; RSV_3 : ON

As this decision point is to deal with an emergency situation, it needs to receive the support as quickly as possible. Hence, the first option from the result is the quickest operation that takes 2.4 minutes. However, the cost for the first option is not the most expensive one from the results. This is because the status of the reserve in Cell1 is OFF for a certain time, and it will cost more to allow it to generate from this cold status.

3.2.2 Decision support for the response to an emergency request from a neighbouring cell for BRC support (USTRATH_DSS_3)

The USTRATH_DSS_3 design, is also based on the UDSS architecture mentioned above in section 3.1.1. This decision point is when the requirement is from a neighbouring cell's point of view, and the decision is about how much support can be offered to the neighbouring cell (frequency event cell). Therefore, the decision support system needs to address how much of its reserves can be provided in this emergency situation. The metrics considered in this case are: time remaining before the next planning phase, the capacity of uncommitted reserves, the capacity of committed reserves and tie-line operation limits between the cells

To achieve this decision point, the KB of the UDSS needs to take these metrics (detailed above) into account to provide a potential plan. Hence, if this cell has a spare capacity which is uncommitted, the KB of UDSS should decide if this can be offered to the problem cell. However, if this cell has committed reserves, the KB of UDSS may decide to offer these reserves to support the other cell, depending on how soon the next planning phase begins. If this real-time operation phase finishes in 10 minutes, compared to it finishing in 2 hours, the KB of UDSS may consider it very low risk to offer committed reserves. As a result, the KB of UDSS does not need to interact with the CSP solver to provide the decision plan within this case.

3.2.3 Decision support for the response to a frequency event due to the loss of a tie-line (RSE_DSS_1)

The primary goal of the RSE Decision Support System (RDSS) is to support the control centre operator in the operation of the power system under control. In the following, a special focus is on those conditions that may endanger the stability of the power system, such as the loss of a tie-line connecting different cells (Figure 3.5).

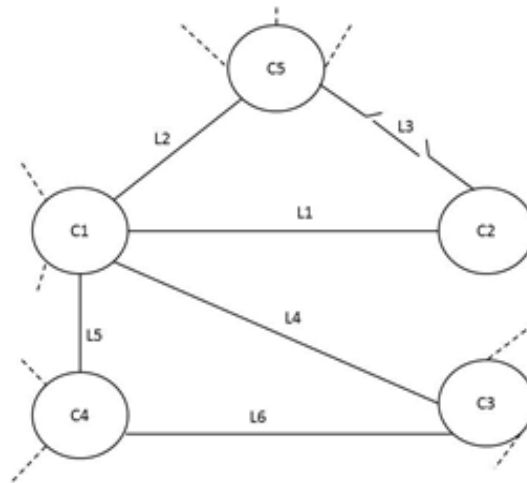

Figure 3-5: Example of network with the loss of a tie-line

When a tie-line is lost an imbalance between load and generation occurs and the system experiences a frequency deviation. The RDSS provides a set of solutions to operate the power system in secure and stable conditions through the identification of those levers that support the system. The levers available to the control room operator are: grid reconfiguration; storage; power plant support; Distributed Generation (DG) contribution; and load modulation.

Grid reconfiguration is an operation performed by the control centre operator to change the topology of the network that can be optimized considering the load and generation profiles to limit/avoid congestions and constraint violations. Hence, grid reconfiguration can be exploited to manage network events and to improve the quality of supply through the adoption of opportune network configurations.

Battery energy storage allows the storage of excess energy in periods of high DERs production and low demand which can be released later, for instance when there is no DERs production and the load is high or during network events. Finally, a further contribution in the management of the power system may come from DG, either in terms of curtailment and injection, and load modulation.

The levers that will be used for the resolution of the network event are ranked by means of a merit order considering the following aspects: activation time; duration of guaranteed behaviour; availability (yes/no); and cost.

The reaction time is the time lever needs to be activated and to begin to provide its support; the duration indicates the time interval when the lever is available to provide a defined support while the availability of a lever indicates if the lever is available.

The cost related to storage, DG and loads are expressed in €/MW injected/absorbed, depending on the operating conditions while the costs associated to the reconfiguration of the grid is equal to the cost of switching operations (related to the consumed lifetime of breakers).

In Figure 3.6 the architecture of the RDSS is presented: the web of cells is observed from the control centre where the operator supervises the dynamic of the whole system. When a network event is identified, the RDSS identifies the levers that may be used for the resolution of the event and enables the activation of the best solution.

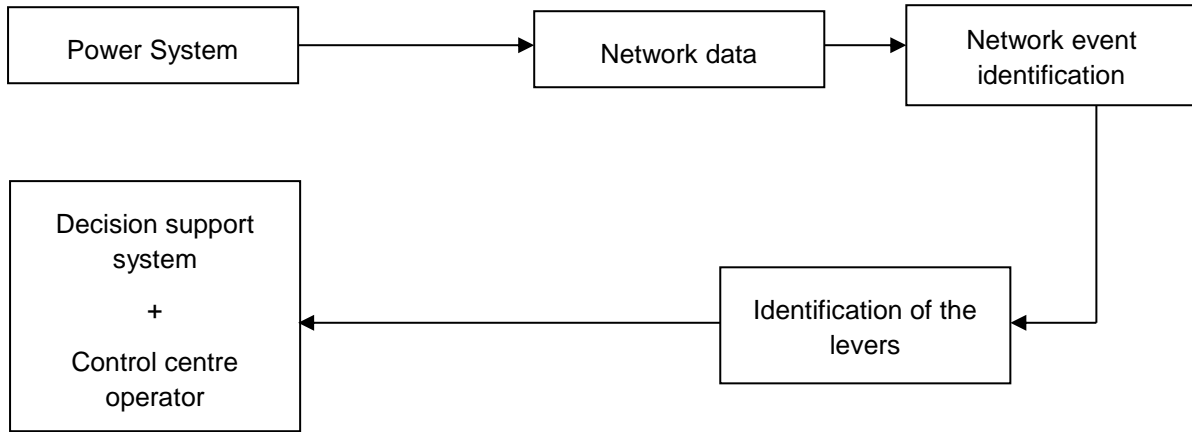

Figure 3-6: RDSS architecture

3.2.3.1 RSE_DSS_1 case study

The case study considers the power system organized with WoC architecture, as shown in Figure 3.7: the four cells (C1 – C4) are connected with each other through tie-lines, exchanging power. For each cell there is a set-point expressed in MVA that is positive if injected in the network. It is negative if absorbed from the network.

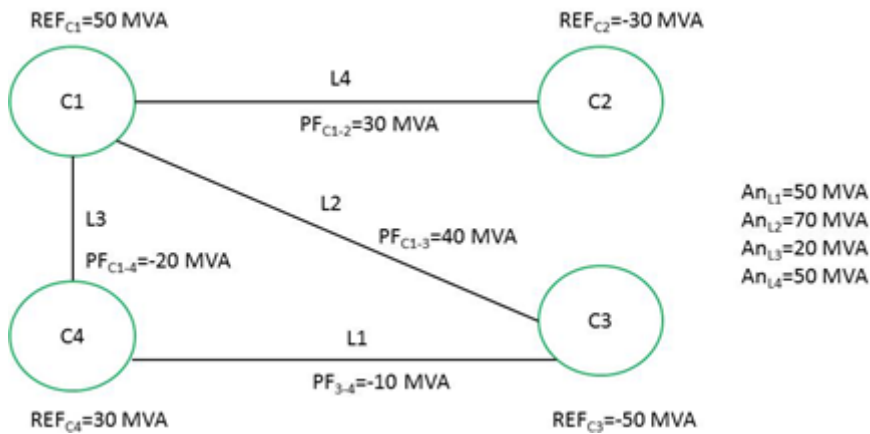

Figure 3-7: WoC in N conditions

In N conditions all the lines are connected, all the constraints are fulfilled and no alarms are sent to the network operator. When the tie-line L1 is lost the automatic circuit breakers open and there is no exchange of power on that line anymore (Figure 3-8). Also in N-1 conditions the cells keep their set-points to the value before the network event and constraint violations do not occur since the tie-lines can transfer all the power.

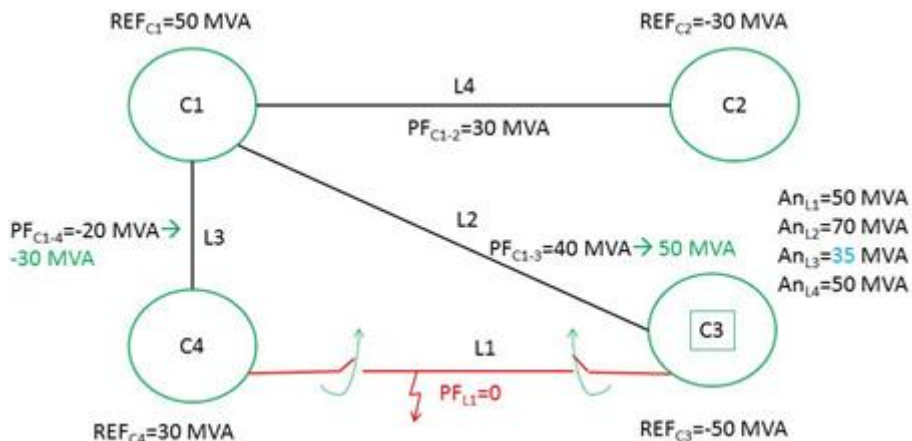

Figure 3-8: WoC in N-1 conditions and no violations

When the loss of L1 implies the violation of a network constraint the new network situation is reported in Figure 3-9: the cell C4 cannot keep its set-point since a constraint violation occurs on line L3. Hence, the new network situation is not acceptable since there is an imbalance between load and generation and constraints are violated.

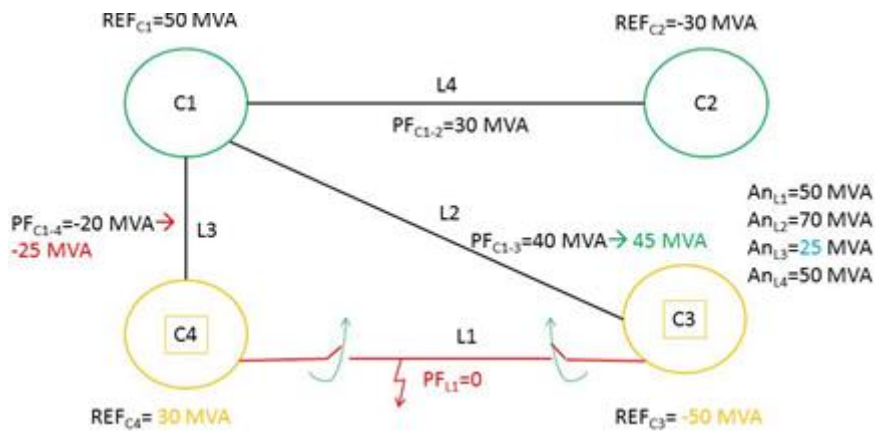

Figure 3-9: WoC in N-1 conditions and violations

The intervention of the RDSS is required and the new network situation is represented in Figure 3-10: in order to fulfil all the network constraints and keep the balance between load and generation the set-points of the cells change.

With respect to the situation before the fault, cells C1 and C2 do not vary their set-points while the set-points of cells C3 and C4 is updated. Consequently, the power flows on the tie-lines connected to C3 and C4 are the only ones to change.

In this situation, the RDSS supports the network operator, highlighting the cells with a different set-point (C3 and C4) and updating the power flows on the tie-lines by means of an OPF. The levers used for reaching the new equilibrium are selected based on a merit order approach, taking into account the above mentioned aspects (i.e. activation time, duration of guaranteed behaviour, availability, cost).

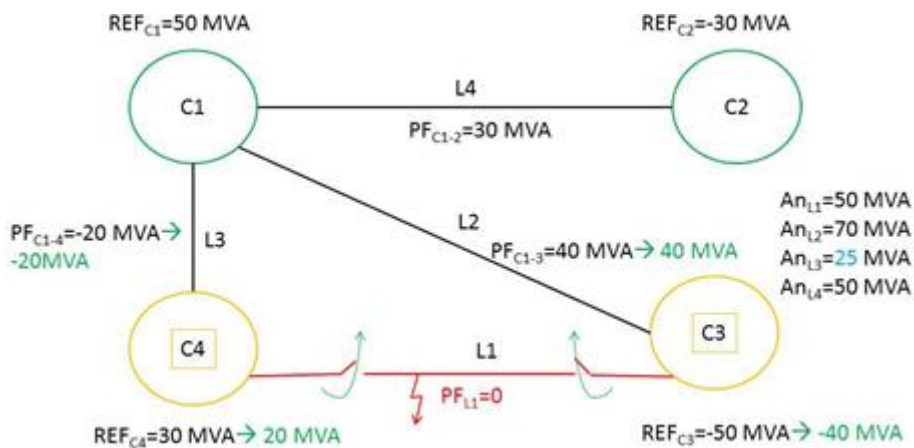

Figure 3-10: WoC in N-1 conditions and change of set-points

After the intervention of the RDSS, the new network situation is reported in Figure 3-11: the fault is isolated and the cells directly involved in the fault have a new set-point. The new network situation (Figure 3-11) fulfils all the network constraints, guaranteeing the balance between load and generation.

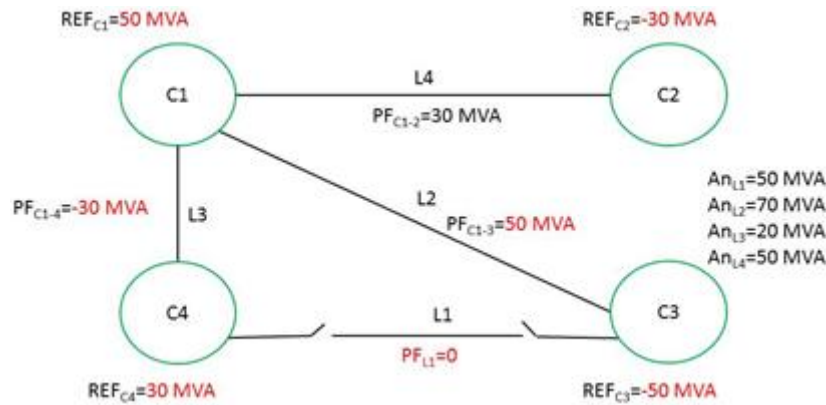

Figure 3-11: Network conditions after the fault clearing

3.3 Decision support system for transient stability preventive control (DTU_2)

It is crucial to assess the transient stability of power systems online on a grid-wide basis and take preventive actions if issues are identified [5, 6]. The proposed decision support tool assesses the CCT of the power system for three-phase faults and calculates the needed re-dispatch of generator if violations of a pre-defined limit are identified i.e. if the CCT for certain contingencies is below the pre-defined limit. The results of the assessment in terms of needed re-dispatch and associated costs are presented to the control room operator who has to decide whether the proposed re-dispatch is applied or not. The operator may also introduce additional constraints, e.g. the unavailability of generators to take over the dispatched power. The decision support tool facilitates experience of previous tools.

3.3.1 Decision support for transient stability preventive control (DTU_DSS_1)

3.3.1.1 Transient stability preventive control approach

Figure 3-12 shows the flow chart of the proposed transient stability preventive control. It comprises the elements which are needed to establish a transient stability control and visualizes how they interact. In the following section, all elements are comprehensively described.

Physical Grid

This block represents the real physical grid, for which the transient stability control is applied. The feedback from the decision support block represents the interaction of the control room operator with the physical grid. The control room operator has to decide and approve whether the proposed dispatch is applied to the system or additional constraints are to be considered in the assessment leading to a new dispatch recommendation.

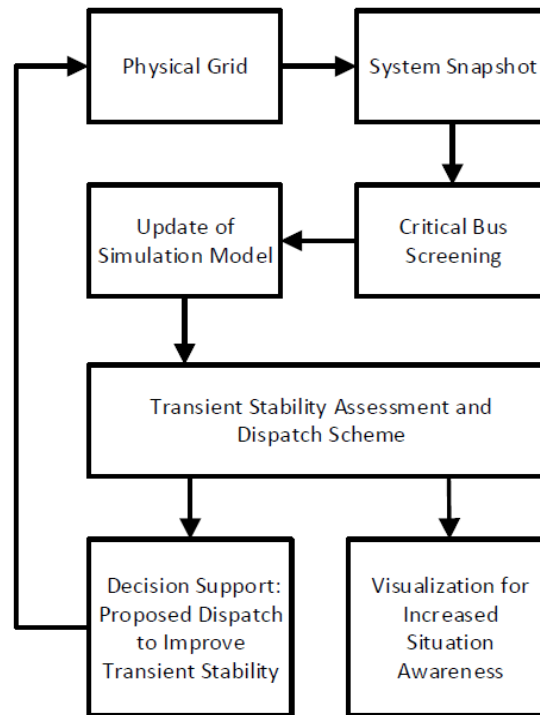

Figure 3-12: Flowchart of the transient stability preventive control approach.

System Snapshot

A system snapshot is needed to update the Time Domain (TD) simulation model with the current system state. Two variants are proposed to obtain a system snapshot. In the first variant, the needed data is extracted from the SCADA system. The needed data includes: breaker status, generation output, activation of capacitor banks, RES generation, line flows and further relevant data. Phasor Measurement Units (PMUs) are another option to obtain a system snapshot, but that assumes full observability of the power system by PMUs. In case, the needed data is not fully available from either of these sources, a hybrid approach could be used by combining SCADA and PMU data to obtain a full system snapshot [7].

Critical Bus Screening

Based on the current system snapshot, a Critical Bus Screening (CBS), which aims at determining the most critical fault locations, is carried out prior to the update of the simulation model. Only busbar faults are considered. Therefore, in the following the term critical buses are used, instead of the more generic term critical fault location. The CBS analyzes the pre-disturbance conditions and filters out the potentially critical buses. The CBS method is based on the work in [8-10]. A heuristic approach is used to identify the buses which are regarded as most critical. Buses are scanned for three criteria indicating their criticality. Only buses which satisfy all three criteria are regarded as critical and qualify for the analysis in the TD simulation. The CBS evaluates three criteria: 1) Bus properties in terms of voltage level and connectivity, 2) Active power injected into the bus versus generator active power and 3) Active power leaving the bus.

Update of Simulation Model

The simulation model, which represents the real power system, has to be updated with data from the current system snapshot. The data includes generator schedule, breaker status, dispatch of capacitor banks and Renewable Energy Sources (RES) generation. The updated simulation model

is then ready to be used in the TD simulation. Additionally, the results of the CBS are saved in a list which contains the identified critical buses. Only these buses are considered in the assessment.

Transient Stability Assessment and Dispatch Scheme

The potentially critical buses are analyzed in the transient stability assessment and dispatch scheme, which is based on a hybrid approach using an estimation of dispatch, combined with TD simulations. The goal of the transient stability assessment and dispatch scheme is to determine the re-dispatch which is needed to achieve the desired critical clearing time while respecting all technical constraints and minimizing costs. The dispatch procedure starts with the Synchronous Generator (SG) which is associated with the bus with the lowest CCT and continues consecutively with CCTs in ascending order. This will deliver a near-optimal solution for the re-dispatch.

3.3.1.2 Case study for visualization and decision support for the control room operator

The capabilities of the approach are demonstrated on the well known New England system with 39 buses [11] and 10 SGs shown in Figure 3.13. The results of the transient stability assessment and the proposed dispatch are presented in comprehensive but condensed form to the control room operator as shown in Figure 3.14. The situation awareness of the control room operator is increased as the stability margin is displayed graphically and the buses, at which the CCT is below the limit, are shown in a table format. Additionally, the generators and their respective dispatch to achieve the desired stability margin are shown numerically. Furthermore, the associated costs of the proposed dispatch are stated.

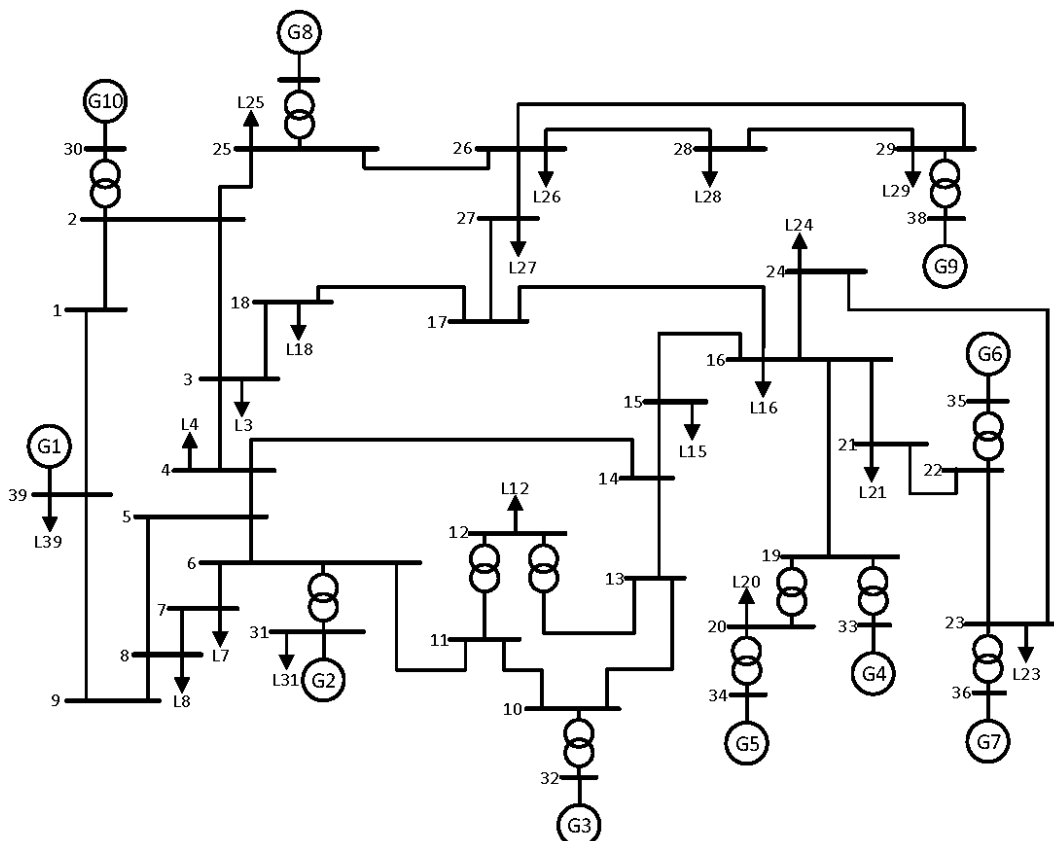

Figure 3-13: New England test system with indication of associated cost functions

It can be seen that all CCTs meet the specified limit after the successful dispatch. The CCTs at bus 23 and 29 are exactly at the limit, whereas bus 22 is even more elevated than it was actually determined. Due to the close proximity of G_7 to G_6 , the dispatch of G_7 also affected the CCT at bus 22. Due to the influence of the generators in close proximity, only a near optimal solution is found

which illustrates one of the drawbacks of the sequential approach but the assessment is carried out in a transparent and traceable way.

The amount of information presented to the control room operator is kept low in order not to overload it and to facilitate fast understanding of the condition. Moreover, warning signals could be generated when the CCT is below a specified limit, e.g. 200 ms. Different levels of severity can then be added depending on the size of the critical unit. If there is a need for in-depth information, the control room operator should be given the possibility to access the underlying data, e.g. reactive power set points.

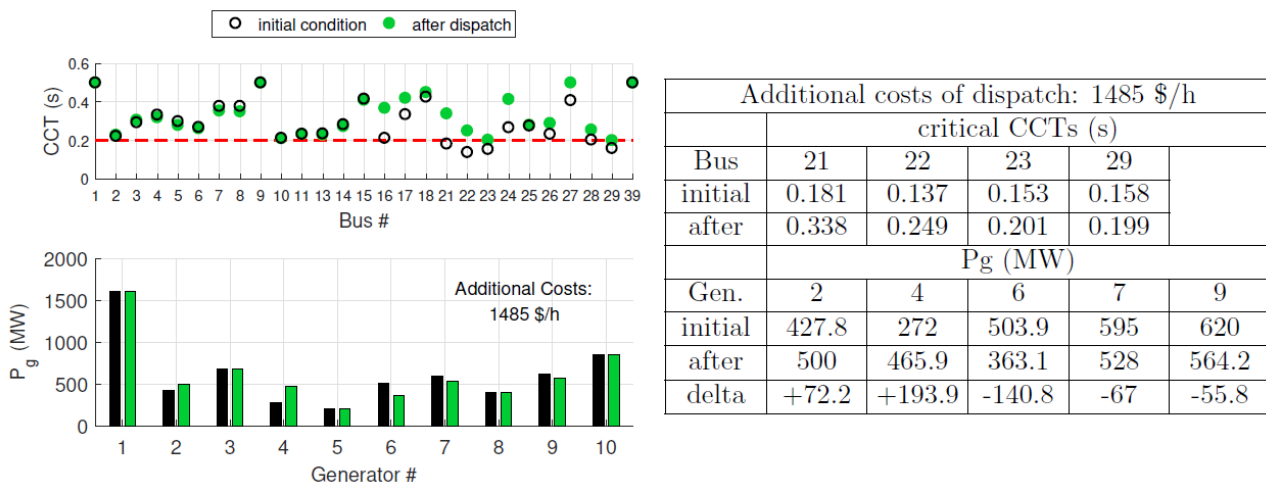

Figure 3-14: CCTs and active power set-points for initial condition and after successful dispatch

3.4 Decision support system for management of inter-cell loop flows (DTU_4)

The loop flow management tool is to be implemented in an inter cell SCADA-system or Distribution Management System (DMS). The main overview is given as a layer in the single line diagram overview.

If inter cell loop flows above planned power flows occur, a warning will be given when the deviation is larger than a given threshold, and it will be possible to activate the loop flow layer to analyse and mitigate the cause of the unscheduled loop flow.

3.4.1. Decision support for management of inter-cell loop flows (SINTEF_DSS_1)

When the loop flow layer is selected, it shows a heat mapping / colour coding of real vs computed power flows in the intercell system (e.g. with green or no colour as no deviation, red for positive deviation, and blue for negative deviation). The purpose of this layer is to give an intuitive overview of cells that are causing the unscheduled loop flows. The cells connecting the tie-lines that show the largest deviations, or cells which show the largest differences in the sum of deviations (i.e. the sum of deviation of all tie-lines to the cell are not zero) are marked with an exclamation mark. These cells can be selected for further inspection, and a similar colour coded Single Line Diagram (SLD) -overview is given within the cell.

For the SLD in the cell, generators with deviating contracted and measured values above a given threshold are marked with exclamation marks. For these generators, three automated tasks can be carried out (in addition to inspecting them manually):

- Generators with exclamation marks are automatically pinged with a new set-point, to see that communications are working. If communication to the generator is down, this is shown with a separate signal in the SLD next to the exclamation mark.
- To check for measurement errors, a subnetwork with a distance of one node in every direction from the generator is created, and a power flow is run with measured power flow values in all nodes. If measured and computed voltages from this simulation do not match, all of these nodes are flagged as "may have malfunctioning measurement equipment", and an automated work order to inspect the instruments is created. The set-points for these generators are then not considered further.
- If the generator is not producing power, and it is shown that both measurement and communication equipment is working, the generator is marked as offline. If the generator is online and is able to receive set points, but does not have enough available power or reactive power, then the generators active and reactive power limits are estimated.

When these three automated subtasks are completed for all marked generators, then the cell-OPF runs a new calculation with the new limits for the affected generators. This task (with subtasks) can be selected for one cell or for all marked cells.

A case study shows an example of how the system may work. The case study is based on Case 5 in a four-cell Pan-European reference power system described in D5.4 "Functional description of the monitoring and observability detailed concepts for the Pan-European Control Schemes" [12]. The synchronous generator SG1.10, placed near Cell 2 and Cell 3 in Cell 1 as seen in Figure 3.15, have deviation between contracted and measured power production and the three automated task mentioned above is tested on this generator.

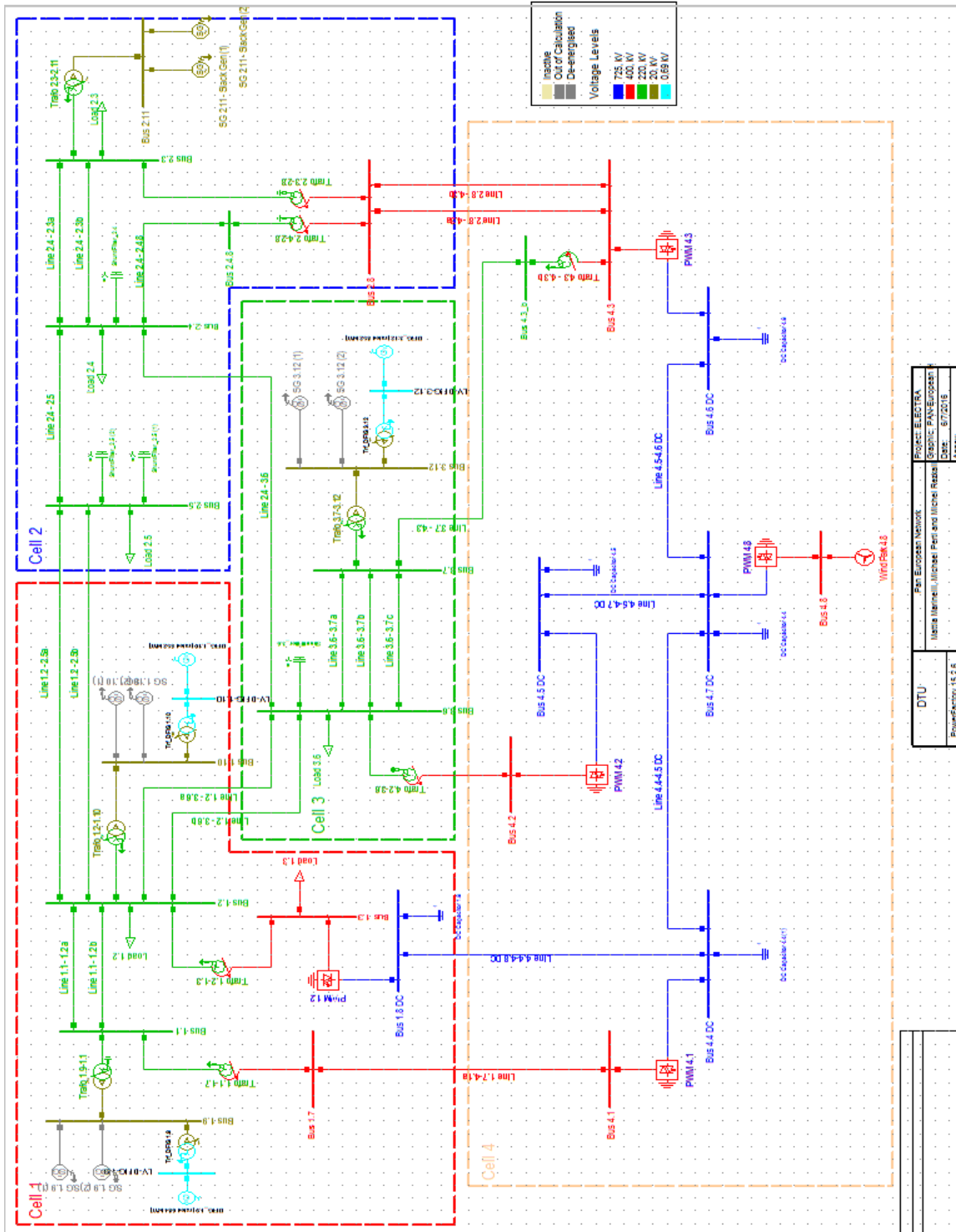

Figure 3-15: Topology of the Pan-European Single Reference Power System.

Firstly, the generator SG1.10 is pinged with a new power set-point. Figure 3.16 (a) shows the measured power flow between the cells before the production of SG1.10 is reduced by 100MW. Both the active and reactive power flow in the tie-lines equals the scheduled power flow and the arrows are therefore coloured green. Figure 3.16 (b) shows the measured power flow between the cells after the production of SG1.10 is reduced by 100MW. In this case, increases in tie-line power flow is marked with red color and decreases are marked with blue colour. In addition, a red exclamation mark shows the tie-line with the largest deviation in active power and another red exclamation mark shows the cells which show the largest differences in the sum of deviations. The unscheduled power flows in Figure 3.16 (c) clearly show that the communication is working.

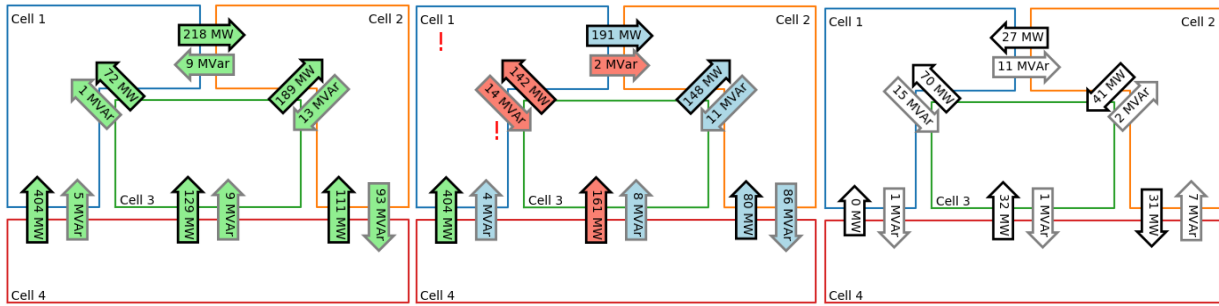

Figure 3-16: Initial load flow (a), load flow after power reduction in SG1.10 (b) and unscheduled power flow after power reduction in SG1.1 (c)

The next step is to check for measurement errors. The measured voltages one node away from SG1.10 are compared to the solution of a load flow based on the measured power flow values in these nodes. The results are shown in Table 3-7 and indicate that there is an error in the voltage measurement on Bus 1.2, since the voltage measurement error is relatively large (2.17%)

Table 3-7: Comparison of measured values and results from power flow on nodes nearby SG1.10

	Bus 1.2		Bus 1.10		LV_DFIG-1.10	
	Voltage [kV]	Angle [degrees]	Voltage [kV]	Angle [degrees]	Voltage [kV]	Angle [degrees]
Measured	220.30	-3.80	20.19	0.00	0.70	-148.40
LF results	225.18	-3.76	20.19	0.00	0.70	-148.34
Error %	2.17		0.00		0.00	
Error degrees		-0.04		0.00		-0.06

The third step is to run a new OPF with the new limitations of SG1.10. The production of SG 1.10 is now reduced from 325 MW to 225 MW and the production gap is covered by SG2.11 in Cell 2. Figure 3.16 compares the load flow before and after a new OPF is run. Figure 3.16 (a) presents the load flow with the initial power production and Figure 3.16 (b) shows the actual load flow with 100 MW production reduction in SG1.10. This production will be covered by SG2.11 in Cell 2 and this causes the need for a new OPF in Cell 1 and Cell 2. Figure 3.17 (a) shows the results of the OPF and the actual power flow (load flow) is shown in Figure 3.17 (b). The unscheduled power flow is shown in Figure 3.17 (c). When comparing Figure 3.16 (c) and Figure 3.17 (c), it is clear that running new OPFs in Cell 1 and Cell 2 will not reduce the unscheduled power flow through Cell 3 and Cell 4. This is caused by a coordination error of voltage set-points between the cells. A new OPF considering all cells is therefore needed.

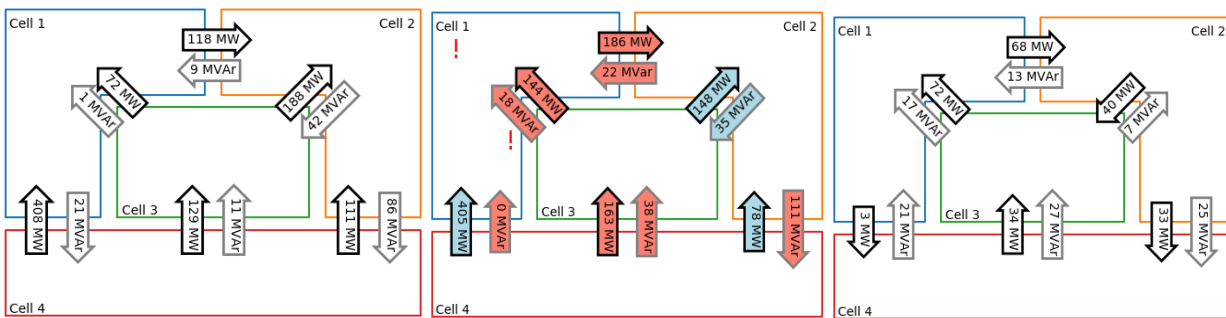

Figure 3-17: Result of updated OPF in Cell 1 and 2 (a), actual load flow after updated OPF (b) and unscheduled power flow after updated OPF (c)

In the inter cell loop flow layer overview, an exclamation mark is also shown in the middle between cells that have differing voltage set-points between the cells. There are valid reasons for having different set-points, but when there is a difference in set-points and an unscheduled power flow after the generator's limits have been adjusted with the previously mentioned task, this would indicate that a coordination error of voltage set-points between cells have occurred. In this case, the user will have a possibility to select the "voltage set-point coordination" task, that runs an algorithm (for instance OPF) to create new voltage set-points.

It is also possible to run a "network configuration check", that sends a query to all line breakers to see if the network configuration shown in SCADA / DMS matches reality. If not, the overview is updated, and the errors marked for further troubleshooting.

If neither of these methods solves the issues, there will be a need for more systematic analysis to determine the root causes for the unscheduled loop flows. The user can still inspect elements manually to see if possible errors are detected, and then have an overview over working and malfunctioning equipment.

In addition to these troubleshooting measures, there is also a safety feature that prevents line overloading. If the loop flow causes a tie-line to exceed its rating, an algorithm (for instance OPF) is run to disconnect non-prioritized load supplied by the loop flow, or generation supplying it. A report is given describing violated constraints, and disconnected units.

3.5 Decision support system for over/under voltage (TEC_2)

The increasing integration of distributed generation in distribution networks may create voltage rise problems due to a growing number of dispersed power injections. These problems may be mitigated by acting on the distributed resources downstream, but the control strategy must be fast and well co-ordinated. If the voltage problems detected are created by the excess generation from RES, it may be necessary to reduce some of those resources power output or even curtail some of them.

To overcome these issues, a voltage control strategy that co-ordinate the operation of the available DER was created in this subtask. This control strategy is based on an OPF tool that manages all available resources to solve voltage problems and minimize power losses.

3.5.1 Decision support for the response to an over/under voltage event NESC_P_DSS_1

The OPF that will be developed has the objective of minimizing losses and will use flexible resources that are considered to be available and managed by cell operators. Some of those resources are the following: storage devices owned by the cell operators; transformers with on-load tap changer; micro-generation resources; and flexible loads.

Two modes of operation are envisaged: corrective and proactive mode. The corrective Post Primary Voltage Control (PPVC) mode is triggered if the voltage in any node is outside the predefined limits. The proactive PPVC mode is always active and is based on an OPF algorithm that is run using short-term load and generation forecasting for the next 15 min interval. The solution of this OPF provides the optimal operation regime of the available controllable resources.

The OPF uses generation/load data and tie-lines power flows as main inputs. Besides, power flow limits of lines, power generation, limits of generators, voltage limits of busbars/terminals (specified by the Regulation), and the amount of available PPVC reserves will be the constraints of the algorithm. The outputs of the algorithm are voltage set-points for PVC nodes (with automatic voltage regulation - AVR - capability), and set-points for capacitor banks, controllable loads, and on-load tap changers (PPVC node controllers).

The voltage control algorithm is assumed to be installed in cell operator control room, which is the entity responsible to manage all assets in a cell.

3.5.1.1 Voltage control algorithm

The innovative part of this voltage control algorithm is the proactive voltage control. Each time period of 15 minutes (CTS-3), the proactive voltage control system will gather information of the tie-lines reactive flows, forecasting data and reserve information, in order to perform an OPF. Then, the set-points provided by OPF will be sent to the respective resources and used for the next time frame of 15 minutes or until a voltage problem occurs.

Beyond the proactive voltage control, it is also necessary a corrective voltage control in case any unexpected voltage problem occurs. A proactive voltage control system will gather the current nodes' voltage values observed from each cell continuously, and will check if they are in a safe band or not every minute. If the voltage values do not exceed the safe band limits, it will move to the next time frame. Otherwise, if the safe band is exceeded, the OPF algorithm will be triggered.

The first step of the corrective algorithm is to gather data from the network, like load and generation values, and perform a power flow to calculate the voltage in the nodes. If any node voltage value exceeds the safe-band limits, an OPF will be run in order to calculate the new set-point that will be sent to the respective resources, using the following data: resources status information, tie-lines active/reactive power set-points and forecast load and generation values. Again, the set-points calculated by the OPF will be used in the next time frame (15 min) or until a new voltage problem occurs.

When a voltage problem occurs and the OPF is triggered, the solution found is presented to the cell operator. The cell operator will have a certain amount of time (e.g. 1 minute) to decide if that solution is to be implemented or not. If no decision is taken in the predefined amount of time, the algorithm will implement the solution found. Otherwise, if cell operator decides that some resource should not be activated, a new solution is calculated considering this information. The diagram of the voltage control algorithm developed is presented in the Figure 3.18. T=15 indicates that the time interval is 15 minutes, which can be generalised for any time period.

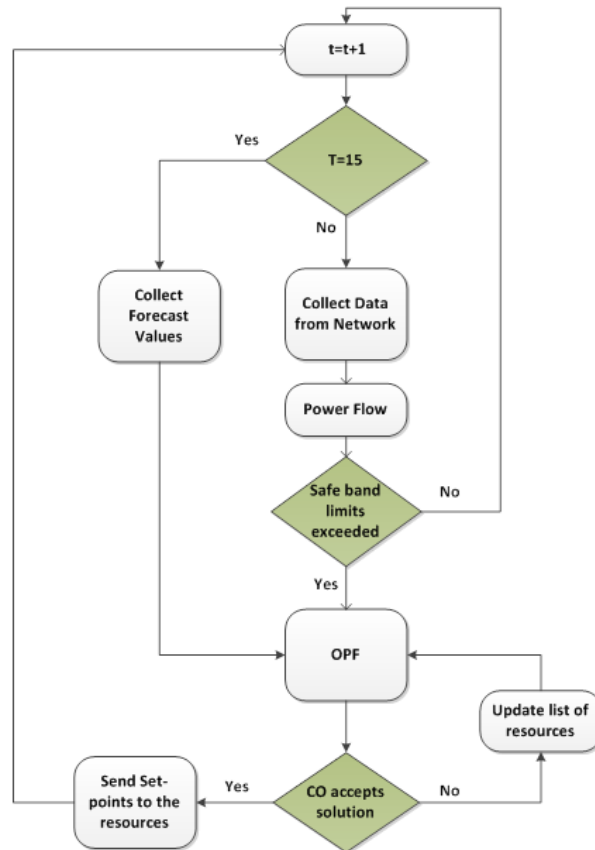

Figure 3-18: Voltage Control Algorithm

3.5.1.2 Case study for visualization and decision support for the control room operator

The network chosen is a Portuguese medium voltage network and it is shown in Figure 3.19. It has 309 buses, that are being supplied by an high voltage network (bus 301 – which is the reference bus), 336 active loads placed in 112 buses and some of those loads have photovoltaic generations. This network is divided into four cells.

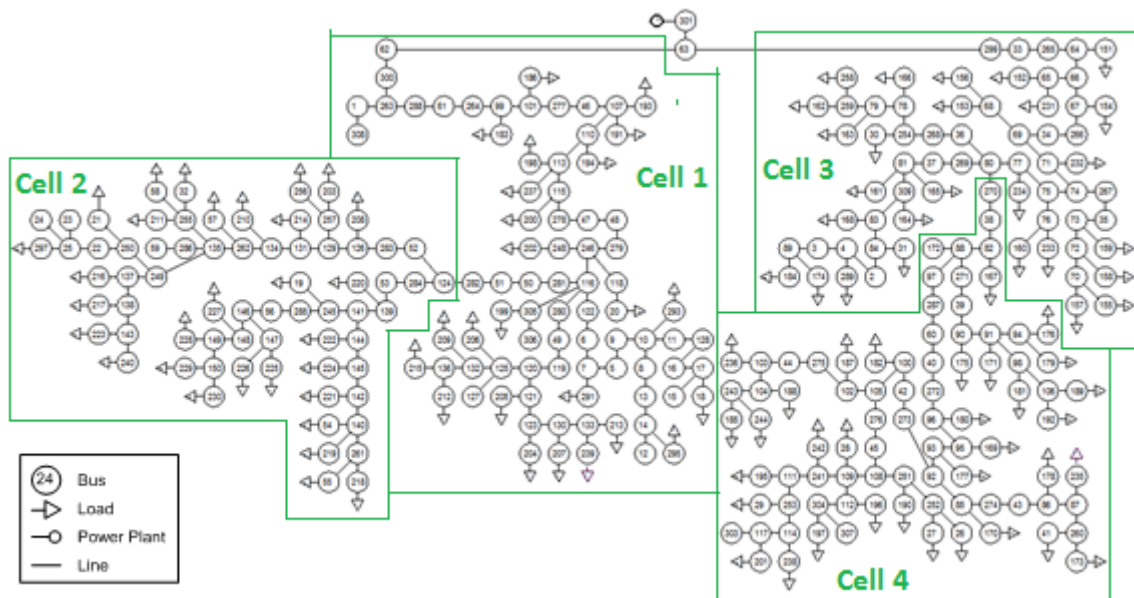

Figure 3-19: - Portuguese MV Network

Cell operator will have access to various information in the control room, such as the bus voltages (highlighting the buses whose voltage is reaching the safe-band limits or those where the voltage limits were violated), the solution of the OPF when a problem occurs, the set points sent to the available resources, etc. Other information like the cost of the solution implemented will also be provided.

The main decision that the cell operator has to take is to accept or reject the solution provided by the OPF in the proactive scenario or the corrective scenario. For example, when the proactive scenario is activated, an OPF will be run and set points will be calculated for the next 15 minutes. However, if cell operator does not want to activate a specific resource, a new OPF will be run not considering that resource. Obviously, this solution is not optimal and costs or energy losses may increase. An example is provided in the following Figure 3.20 and Figure 3.21, where it is shown that the exclusion of a certain resource (flexible loads 26 and 28 of Cell 4) induces changes in the voltages and energy losses.



Figure 3-20: Voltage values in some nodes of the considered Portuguese network

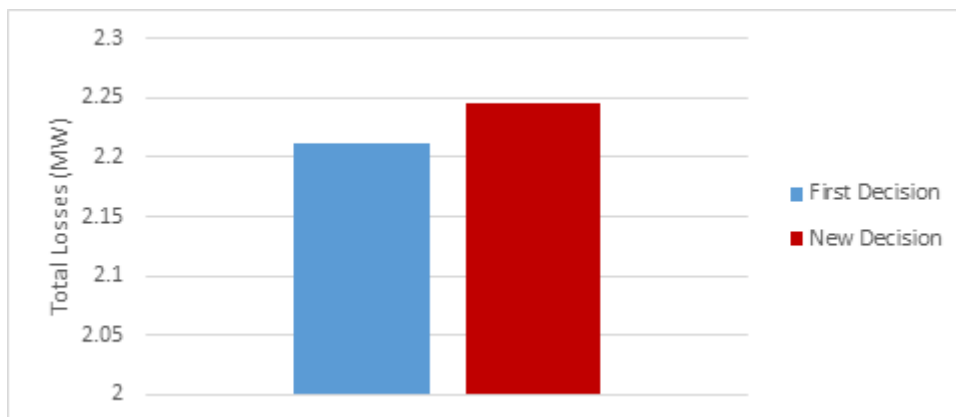

Figure 3-21: Total losses of the considered Portuguese distribution system

As we can observe from Figure 3.20, the voltages in some of the nodes decreased, although none of them surpassed the limits. Figure 3.21 shows that the total losses in the cell increased with the exclusion of flexible load 26 and 28.

4 Conclusions

This report, and Deliverable, details the development and demonstration of decision support for operators of the future WoC framework. It builds on the scenarios presented in ELECTRA Deliverable 8.2, which specified requirements for visualisations and analytics to assist the operator. The aim is to identify critical decisions within these scenarios, define available control actions for these decisions and prioritise actions for the operator. As a result, a methodology for developing decision support demonstrators is proposed.

Based on the WoC architecture, the DSS should have specific requirements that differ from current network management. Therefore, for the scenarios selected, one or more decision points within these scenarios have been identified and various actions that the operator (or automated control system) could take are specified. Moreover, metrics for selecting between alternative actions to resolve the decision have been determined with the intended outcome for each decision point.

According to the functional specification of decision points within the selected scenarios, decision support systems have been designed to operate under the WoC framework. Appropriate tools, methods and control algorithms have been selected. In order to implement the DSS, case studies have been developed to test the proposed decision points.

This Deliverable provides novel solutions to a range of problems tackled from a Web of Cells functionality viewpoint, which means that it considers a level of automation and interaction with neighbouring cells which is absent in other research projects. The solutions specified will now be prototyped and assessed, with a particular emphasis on how they can be combined within the WoC control, automation and decision support platform. A range of control issues are covered i.e the assessment of transient stability margins and critical clearing time, imbalance in tie line flow, loss of mains, over voltage curtailment and procurement of reserves (following single and double frequency deviations) are the scenarios. Enhancements in the use of OPF, and novel knowledge based and constraint satisfaction approaches to automatically identifying control decisions have been investigated. These will now be built and their performance assessed, along with their suitability for combination within WoC control. This will also allow the assessment of the future role of an operator within the WoC.

The DSS needs to operate with visualisations that allow the operator to observe the system state at a glance and enable intuitive situational awareness. As a result, some of these decision support systems will combine reasoning algorithms with visualisations, which are designed in Task 8.2, to relay key information to the operator and to assist them in making accurate decisions and taking action quickly.

5 References

- [1] <http://www.electrairp.eu> (ELECTRA IRP web site).
- [2] ELECTRA IRP, "D8.1: Demonstration of Visualization Techniques for the Control Room Engineer in 2030," 2016.
- [3] K. R. Apt. Principles of Constraint Programming, Cambridge University Press, 2003.
- [4] Omar, N., Bossche, P. V. D., Coosemans, T., & Mierlo, J. V. (2013). Peukert revisited—critical appraisal and need for modification for lithium-ion batteries. *Energies*, 6(11), 5625-5641.
- [5] T. Weckesser, H. Johannsson, S. Sommer, and J. Østergaard, "Investigation of the Adaptability of Transient Stability Assessment Methods to Real- Time Operation," in 3rd IEEE PES International Conference and Exhibition on Innovative Smart Grid Technologies (ISGT Europe), 2012, pp. 1–9.
- [6] M. Pertl, M. Rezkalla, and M. Marinelli, "A Novel Grid-Wide Transient Stability Assessment and Visualization Method for Increasing Situation Awareness of Control Room Operators," in IEEE PES Innovative Smart Grid Technologies Conference Asia (ISGT), 2016, pp. 1–6.
- [7] M. Glavic and T. Van Cutsem, "Reconstructing and tracking network state from a limited number of synchrophasor measurements," *IEEE Trans. Power Syst.*, vol. 28, no. 2, pp. 1921–1929, 2013.
- [8] V. Kolluri, S. Mandal, M. Y. Vaiman, M. M. Vaiman, S. Lee, and P. Hirsch, "Fast Fault Screening Approach to Assessing Transient Stability in Entergy's Power System," in IEEE Power Engineering Society General Meeting, 2007, pp. 1–6.
- [9] S. Lee, L. Min, and M. Vaiman, "Fast Fault Screening for Real-Time Transient Stability Assessment," 2010.
- [10] M. Y. Vaiman, M. M. Vaiman, and A. Gaikwad, "Fast Fault Screening Methodology for Transient Stability Analysis of Bulk Power Systems," in IEEE Power and Energy Society General Meeting, 2013, pp. 1–5.
- [11] T. Athay, R. Podmore, and S. Virmani, "A Practical Method for the Direct Analysis of Transient Stability," *IEEE Transactions on Power Apparatus and Systems*, vol. PAS-98, no. 2, March/April 1979, pp. 573-584.
- [12] Marinelli, Mattia, et al. "Functional description of the monitoring and observability detailed concepts for the Pan-European Control Schemes: ELECTRA Deliverable D5. 4. WP5: Increased Observability." (2017).

6 Disclaimer

The ELECTRA project is co-funded by the European Commission under the 7th Framework Programme 2013.

The sole responsibility for the content of this publication lies with the authors. It does not necessarily reflect the opinion of the European Commission.

The European Commission is not responsible for any use that may be made of the information contained therein.