

VALIDATION OF COLPITTS VCO DESIGN FOR TWO WAY PORTABLE RADIO APPLICATIONS

By

ALDRIN RAJ ARUL

**A dissertation submitted for partial fulfilment of the requirement for
the degree of Master of Science**

June 2013

ACKNOWLEDGEMENT

The road leading to degree was told to be long journey of perseverance and indeed it was. I was fortunate in obtaining divine grace in enduring the path full of trial and tribulations in the labour of studies while working for the past 1 year. Many individuals deserve warm gratitude for making this thesis a reality.

First and foremost, I would like to thank my supervisor, Dr. Shahid Iqbal for his monumental guidance throughout this postgraduate program. His vocabulary of knowledge and vast experience have assisted me in identifying the problem arises throughout the project and the maturity to overcome the obstacles. I look up to him as an excellent research advisor and would like express my utmost gratitude. Thank you again Dr. Shahid Iqbal.

I am indebted to Dr. Narendra Kumar who is a senior technical staff design engineer of Motorola Technologies. His professionalism and great technical advice as well as enthusiastic technical inputs have inspired me to continuously challenge myself to reach new levels.

Last but not least, my acknowledgements would not be complete without expressing my gratitude to fellow working colleagues for their unconditional love, support and care throughout my studies. Their love and overwhelming support in the face of any obstacles or adversity I faced was not only instrumental but essential in the completion of this thesis. I would not be where I am today without their contributions and foundations that they have provided throughout the years.

Dedications to my beloved Mum and Dad

TABLE OF CONTENTS

ACKNOWLEDGEMENT	ii
TABLE OF CONTENTS.....	iv
LIST OF TABLES.....	vii
LIST OF FIGURES	viii
LIST OF ABBREVIATIONS AND NOMENCLATURE.....	xii
ABSTRACT.....	xiii
ABSTRAK.....	xiv
CHAPTER 1	1
INTRODUCTION	1
1.1 Overview.....	1
1.2 Research Motivation.....	2
1.3 Thesis Objective	3
1.4 Research Methodology	3
1.5 Thesis Outline	3
CHAPTER 2	5
LITERATURE REVIEW	5
2.1 Introduction.....	5

2.2 Voltage Controlled Oscillation Topologies	7
CHAPTER 3	11
THEORY	11
3.1 Introduction.....	11
3.2 Oscillator.....	13
3.3 Barkhausen Oscillation Criterion.....	14
3.3.1 Barkhausen Criterion Derivation.....	15
3.3.2 Barkhausen Criterion Limitation.....	20
3.4 Nyquist Plot	20
3.5 Gain and phase response.....	24
3.6 Resonance	26
3.6.1 Series LC Circuit	26
3.6.2 Parallel LC Circuit.....	29
3.7 Negative resistance oscillators.....	32
3.7.1 Negative Resistance Approach in Colpitts Design Oscillator	32
3.8 Voltage Controlled Oscillator (VCO).....	38
3.9 Varactor	40
3.10 Noise	44
3.10.1 Phase Noise	46
CHAPTER 4	52
IMPLEMENTATION.....	52

4.1 Introduction.....	52
4.1.1 VCO design requirement.....	52
4.1.2 VCO design	53
4.1.3 Circuit Implementation.....	54
4.2 Methods of verification of the design.....	56
CHAPTER 5	59
RESULTS AND DISCUSSION	59
5.1 Overview.....	59
5.2 Control Voltage, $V_{control}$ and K_v	60
5.2.1 Control Voltage and K_v	61
5.2.2 $V_{control}$	69
5.3 Guardband.....	75
5.4 SBNR or Phase Noise	77
5.5 Hum and Noise	82
5.6 Current	85
CHAPTER 6	87
CONCLUSION.....	87
6.1 Overview.....	87
6.2 Results Summary	88
6.3 Future Work and Direction.....	89
REFERENCES	90

LIST OF TABLES

Table 4-1: Guardband simulation results	54
Table 5-1: Test frequencies for all measurement.....	59
Table 5-2: Test plan	60
Table 5-3: Vcontrol at room temperature	70
Table 5-4: Vcontrol at cold temperature.....	70
Table 5-5: Vcontrol at hot temperature.....	71
Table 5-6: VCO1 Guard Band Details.....	76
Table 5-7: VCO2 Guard Band Details.....	76
Table 5-8: Both VCOs current drain at room temperature	85
Table 5-9: Both VCOs current drain at cold temperature.....	86
Table 5-10: Both VCOs current drain at hot temperature.....	86

LIST OF FIGURES

Figure 2-1: Basic diagram of types of VCO and its output	7
Figure 3-1: Research Methodology Flow Chart	12
Figure 3-2: Types of Oscillators by group type (Allen, 2003)	14
Figure 3-3: The basic feedback circuit.....	15
Figure 3-4: An example of Nyquist plot (Chan, 2013).....	21
Figure 3-5: Open-loop form of an oscillator with negative feedback.....	22
Figure 3-6: Example of putting a closed-loop oscillator into an open-loop form	23
Figure 3-7: Example of negative feedback oscillator open-loop gain and phase response.....	24
Figure 3-8: Series LC circuit.....	27
Figure 3-9: Relationship between Capacitance and inductance in series LC	29
Figure 3-10: Parallel LC Circuit	30
Figure 3-11: Relationship between Capacitance and inductance in parallel LC	31
Figure 3-12: A basic Colpitts oscillator.....	32
Figure 3-13: Small-signal model for Colpitts oscillator.	33

Figure 3-14: Equivalent negative resistance circuit.....	35
Figure 3-15: Voltage tuning method.....	39
Figure 3-16: A full VCO block using the Colpitts negative resistance design.....	40
Figure 3-17: Varactor symbol.....	41
Figure 3-18: A varactor diode <i>pn</i> junction.....	41
Figure 3-19: Relationship between biasing voltage and capacitance	43
Figure 3-20: Reverse bias voltage vs Capacitance	44
Figure 3-21: Ideal case oscillator output.....	47
Figure 3-22: Practical case oscillator output.....	47
Figure 3-23: Conceptual view of single side band phase noise	49
Figure 4-1: Conceptual view of single side band phase noise	55
Figure 5-1: VCO1 Control Voltage plot at room temperature.....	61
Figure 5-2: VCO1 Kv plot at room temperature.....	62
Figure 5-3: VCO1 Control Voltage plot at cold temperature	62
Figure 5-4: VCO1 Kv plot at cold temperature	63
Figure 5-5: VCO1 Control Voltage plot at hot temperature	64

Figure 5-6: VCO1 Kv plot at hot temperature	64
Figure 5-7: VCO2 Control Voltage plot at room temperature.....	65
Figure 5-8: VCO2 Kv plot at room temperature.....	66
Figure 5-9: VCO2 Control Voltage plot at cold temperature	66
Figure 5-10: VCO2 Kv plot at cold temperature	67
Figure 5-11: VCO2 Control Voltage plot at hot temperature	68
Figure 5-12: VCO2 Kv plot at hot temperature	68
Figure 5-13: Monte Carlo - VCO1 at lower end.....	72
Figure 5-14: Monte Carlo - VCO1 at upper end.....	73
Figure 5-15: Monte Carlo – VCO2 at upper end	74
Figure 5-16: Monte Carlo – VCO2 at upper end	74
Figure 5-17: Guardband in a snapshot.....	75
Figure 5-18: Both VCOs SBNR for 12.5 kHz at room temperature.....	77
Figure 5-19: Both VCOs SBNR for 20 kHz at room temperature.....	77
Figure 5-20: Both VCOs SBNR for 25 kHz at room temperature.....	78
Figure 5-21: Both VCOs SBNR for 12.5 kHz at cold temperature	79

Figure 5-22: Both VCOs SBNR for 20 kHz at cold temperature	79
Figure 5-23: Both VCOs SBNR for 25 kHz at cold temperature	80
Figure 5-24: Both VCOs SBNR for 12.5 kHz at hot temperature	80
Figure 5-25: Both VCOs SBNR for 20 kHz at hot temperature	81
Figure 5-26: Both VCOs SBNR for 25 kHz at hot temperature	81
Figure 5-27: Both VCOs Hum Noise performance at room temperature	82
Figure 5-28: Both VCOs Hum Noise performance at cold temperature	83
Figure 5-29: Both VCOs Hum Noise performance at hot temperature	84

LIST OF ABBREVIATIONS AND NOMENCLATURE

VCO	Voltage Controlled Oscillator
DC	Direct Current
LC	Inductor and Capacitor configuration
PTT	Push-to-Talk
RF	Radio Frequency
FOM	Figure of Merit
AC	Alternating Current
Vctrl	Voltage Control
VCC	Supply Voltage
SBNR	Side Band Noise Ratio
VHF	Very High Frequency
IC	Integrated Circuit
RFIC	Radio Frequency Integrated Circuit
LPF	Low Pass Filter
BJT	Bi-polar Junction Transistor
H&N	Hum and Noise
ATEX	Explosive Environment

VALIDATION OF COLPITTS VCO DESIGN FOR TWO WAY PORTABLE RADIO APPLICATIONS

ABSTRACT

The Voltage Controlled Oscillation, VCO is one of the most important building blocks in modern communication applications such as the wired and wireless communications devices. The oscillator is always been regarded as the ‘heart’ of a two way radio communication devices currently available in the market (Scalpi, 2008). Along the years major effort to produce the best VCO design have been carried out intensively and progressively. The challenge is to find a solution in validating a design that is robust and efficient yet cost effective VCO design in par with the current market demands. This research highlights the best possible ways to validate a VCO design which is using the Colpitts VCO design topology. This validation proves that the VCO design is a robust and efficient. This research also discusses about the key areas that requires proper attention during the design of a VCO design for a two way radio communication devices to ensure that the design is robust and efficient.

PENGESAHAN REKABENTUK VCO COLPITTS UNTUK APLIKASI SISTEM RADIO DUA HALA

ABSTRAK

Pengayun Terkawal Voltan, VCO merupakan salah satu aspek penting bagi blok binaan aplikasi komunikasi moden yang berwayar dan tidak berwayar dalam era komunikasi kini. Jelasnya, pengayun ini sentiasa dianggap sebagai nadi penting dalam komunikasi radio dua hala yang kini di dapati di pasaran (Scalpi, 2008). Usaha untuk menghasilkan reka bentuk VCO yang terbaik telah dijalankan secara intensif dan berterusan dari penemuannya hingga kini. Halangan yang paling mencabar adalah untuk mencari jalan penyelesaian dalam pengesahan rekabentuk pengayun terkawal voltan yang terbaik, teguh dan kos efektif selaras dengan permintaan pasaran semasa. Kajian ini memaparkan cara yang terbaik untuk megesahkan rekabentuk sistem pengayun terkawal voltan yang menggunakan kaedah Colpitts supaya ianya cekap dan mantap. Penyelidikan ini juga membincangkan aspek-aspek lain yang merupakan elemen penting yang memerlukan perhatian yang mendalam terhadap alat alat komunikasi seperti radio dua hala bagi memastikan rekabentuk VCO yang cekap dan teguh.

CHAPTER 1

INTRODUCTION

1.1 Overview

A voltage-controlled oscillator or VCO is an electronic oscillator designed to be controlled in oscillation frequency by a voltage input. The frequency of oscillation is varied by variation on the direct current, DC voltage applied to the whole system. This method allows the user to manipulate the DC voltage applied to obtain the desired oscillation frequency.

Colpitts design is one the many oscillation techniques used in the Electronic design. This method is using the combination of inductance, L and capacitor, C. This technique is also known as LC oscillator. And the distinct different between the Colpitts technique and the other techniques used to design the oscillator is that the feedback signal is taken from a voltage divider made by two capacitors in series.

One of the methods frequently used in oscillator analysis is to determine the input impedance of an input port. This impedance value will not take into account any reactive components involved. And if the input impedance yields a negative resistance then an oscillation is possible. This method is known as the negative resistance analysis. Negative resistance is a property of some electric circuits where an increase in the current entering a port results in a decreased voltage across the same port (Collins, 2013). This technique

is totally in contrast to a simple ohmic resistor, which exhibits an increase in voltage under the same conditions.

To stay ahead in this competitive market and at the same time providing a better product that can enhance or help the user efficiently whenever it matters, a portable communication device must be produced with a robust design and minimum cost. Therefore in this case a VCO design plays a very important role in achieving the goals mention above. In realization of this problem and risk, strategies and efforts to design a robust VCO design system at a minimum costs in the current portable radios will be carried out intensively so that an amicable solution can be found to cater for the market needs as and when it is needed.

1.2 Research Motivation

It is known that VCO have been subjected to various research and analysis. An improved design of VCO has been identified as a critical requirement for the portable radio communication system nowadays in the competitive market environment.

The idea of this research came into picture when a VCO design was required in a new design of portable radio using improved communication network system in Motorola Solutions. This design is to be designed to be highly efficient and cost effective. Also it needed to be able to be integrated into the full operating system of the radio.

1.3 Thesis Objective

The objective of this thesis is to design and validate a Colpitts oscillator for Voltage Controlled Oscillator design, VCO catering mainly for VHF band frequencies. This design is to be used as a subsystem in the two way radio communication devices.

The operation and performance of the design is to be tested and evaluated for various parameters such as the sensitivity, guardband, phase noise, hum and noise and current. The validation is to prove that the design is both robust and efficient.

1.4 Research Methodology

Upon the completion of the literature review, the concept design will be designed. This final design will be then transferred to concept board as a proof of the concept. This populated board will be measured using external equipments and all the data and results will be collected for validation of the total design.

1.5 Thesis Outline

This thesis is organized in 6 chapters. Each of the chapter was written according to the progress of the report. Chapter 1 is the introduction part of the project which covers

the objective of the project. In order to get a better view of the project, the research's motivation and the design goals are also included.

The literature review is presented in Chapter 2. The survey on the topologies that is used in VCO and the advantages and disadvantages of the topologies are discussed here to understand the best topology.

Chapter 3 describes the definition and term of key parameters that is used in analyzing the VCO topology. It also discusses on the role of these key parameters in VCO topology

Chapter 4 demonstrates the detailed aspects of hardware. The details of circuit construction, regulation selection and structuring of the proposed Colpitts VCO design are presented in this chapter.

Chapter 5 presents the results and discussion of the testing that have been conducted on the proposed Colpitts VCO designs.

And the final chapter, Chapter 6, provides the conclusions and suggestions for future work that can be realized for this project.

CHAPTER 2

LITERATURE REVIEW

2.1 Introduction

Portable radios, also known widely as Walkie Talkie, are two way portable communications devices. Its development dates back to World War II. Its development has been variously credited to Donald L. Hings, radio engineer Alfred J. Gross, and the engineering teams at Motorola, formerly known as Galvin Manufacturing Company of Chicago (Leonard, 2005). The team consisted of Dan Noble, who conceived of the design using FM technology, Henryk Magnuski who was the principal RF engineer, Marion Bond, Lloyd Morris, and Bill Vogel (Wolinsky, 2003). Even though it was initially developed for the armed forces but eventually after the war its usage has spread to public safety and subsequently to commercial usage. Today the portable devices are also the main communication devices used in most of mission critical agencies besides military worldwide as fire service, police forces and medical agencies due to its main advantages compared to other communication devices such as:

- Real time communication – Two way radio provides instant or real time communication where the user has to only press the ‘Push-To-Talk’ (PTT) button and within a fraction of second the user is able to talk and convey their messages.

This is one of the key factors many organizations rely on for their day to day tactical and operational communication.

- Group communication – Another distinct feature in two way radios are its capability in enabling ‘one-to-many’ calls efficiently. This capability allows single user to convey their messages to multiple listener at the same time in real time.
- Mobility – Due to two way radios design whereby it incorporates both transmitting and receiving capability without any assistance from external applications or devices it is very mobile. Any users with a set of two way radios are able to bring the devices to almost any terrain or location and still be able to convey and receive messages.

As mentioned in Chapter 1, Voltage Controlled Oscillator (VCO) is one the main building block in the two way radio system. Having said that, the portable systems such as two way radios are very much dependent on VCO performances and designs. Thus the need for a robust and efficient VCO design is always been the core subject in discussions among the RF designer worldwide and are rapidly growing in demand (Behzad Saeidi, 2010).

2.2 Voltage Controlled Oscillation Topologies

In the history of Radio Frequency (RF) devices growth, the VCO block has been evolved rapidly thus giving birth to many designs and topologies. Referring to lecture notes from Prof. C. Patrick Yue, from the Hong Kong University of Science and Technology, all the VCO topologies can be categorized into two main types. These are the LC Oscillator and Ring Oscillator (Yue, 2013). Below is the basic diagram showing the setup of both types of VCO and the output waveform from the VCO types.

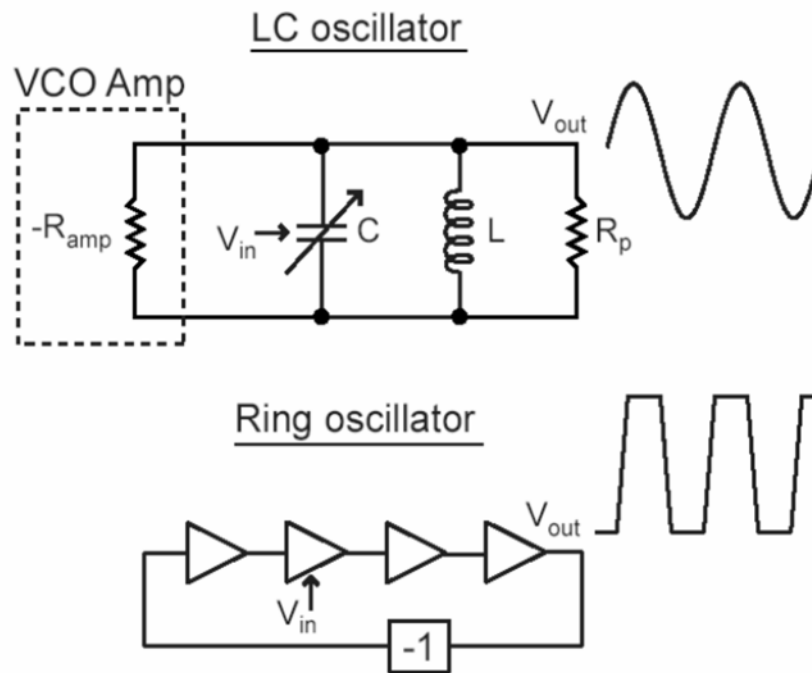

Figure 2-1: Basic diagram of types of VCO and its output

The LC Oscillator is also commonly referred as the Harmonic Oscillator while the Ring Oscillator is also commonly referred as the Relaxation Oscillator (Choudhuri, 2011).

- Harmonic Oscillator generates a sinusoidal waveform as shown in the Figure 2-1. It consists of an amplifier, *-Ramp*, which provides adequate gain and a resonant circuit that feeds back signal to the input. Oscillation occurs at the resonant frequency where a positive gain arises around the loop.
- Relaxation Oscillator generates sawtooth or triangular waveform providing wide range of operational frequency with minimum external components. The amount of time in each state is defined by the time for the current to charge and discharge the capacitors in use.

Both the reference also implies that the LC Oscillator or the Harmonic Oscillator type VCO are widely used in the RF devices by citing the advantage as the performance are better in terms of frequency stability and phase noise performance. It is also important to note that the Colpitts VCO design topology is also part of the LC Oscillator type.

The papers previously described the LC Oscillator or Harmonic oscillator as the more correct option in designing a VCO for RF communication devices based on the theoretical justification. But the question raises as what are the popular and widely used VCO type in and around the RF communication world in reality. There are several VCO topologies that have been widely used in the modern communication systems available in the world. Those systems identified are including Colpitts, differential Colpitts cross-

coupled, complementary cross-coupled and complementary Colpitts. Among all these structures, the Colpitts Oscillator has the inherent advantages in terms of the phase noise. A proposition of a new Figure of Merit (FOM) which includes the tuning range besides the center frequency, Phase Noise and current supply was introduced in determining the overall performance metrics of the VCO types. The equation for with and without the tuning range inclusion are given as below.

$$FOM = 10 \log \left[\left(\frac{F_{center}}{\Delta f} \right)^2 \frac{1}{L(\Delta f) V_{dd} I} \right] \quad (2.1)$$

In this FOM equation, F_{center} is the oscillation frequency, Δf is the frequency offset, $L(\Delta f)$ is single sideband phase-noise at the frequency offset, V_{dd} is the supply voltage, and I is the tail bias current. The following is the new proposed FOM which includes the tuning range, T_r , represented as a percentage.

$$FOM_{new} = 10 \log \left[\left(\frac{F_{center}}{\Delta f} \right)^2 \frac{100 * T_r}{L(\Delta f) V_{dd} I} \right] \quad (2.2)$$

Based on the new metrics results it shows that the Colpitts Oscillator is the best candidate for VCO Design topology although the initial FOM result also implies that the Colpitts Oscillator design is a better candidate (Zhang, 2006). So in overall it can be said that the Colpitts Oscillator design approach for a VCO design is far more superior in terms of not

only the tuning range but also in terms of Phase Noise performance, frequency accuracy and power consumption. Another paper, by Swati Yadav, highlighted that high stability is required to improve the efficiency in VCO designs. It states Colpitts Oscillator is designed for generation of high frequency sustained oscillator and the Colpitts Oscillator types are the most widely used oscillator topology for commercial purposes (Swathi, 2013).

By going through all these papers it is quite clear that the best option for a VCO design is the Colpitts Oscillator. It is known for high performances such as low Phase Noise, frequency accuracy, low power consumption, high stability and wide tuning range. Colpitts design is also robust and efficient. Therefore in this thesis the choice of VCO topology will be the Colpitts Oscillator design.