



Barratt, S. L., Flower, V. A., Pauling, J. D., & Millar, A. B. (2018). VEGF (Vascular Endothelial Growth Factor) and Fibrotic Lung Disease. *International Journal of Molecular Sciences*, 19(5), [1269].
<https://doi.org/10.3390/ijms19051269>

Publisher's PDF, also known as Version of record

License (if available):
CC BY

Link to published version (if available):
[10.3390/ijms19051269](https://doi.org/10.3390/ijms19051269)

[Link to publication record in Explore Bristol Research](#)
PDF-document

This is the final published version of the article (version of record). It first appeared online via MDPI at <http://www.mdpi.com/1422-0067/19/5/1269> . Please refer to any applicable terms of use of the publisher.

University of Bristol - Explore Bristol Research

General rights

This document is made available in accordance with publisher policies. Please cite only the published version using the reference above. Full terms of use are available:
<http://www.bristol.ac.uk/pure/about/ebr-terms>



Review

VEGF (Vascular Endothelial Growth Factor) and Fibrotic Lung Disease

Shaney L. Barratt ^{1,*}, Victoria A. Flower ², John D. Pauling ² and Ann B. Millar ¹

¹ Academic Respiratory Unit, School of Clinical Sciences, University of Bristol, Bristol BS10 5NB, UK; ann.millar@bristol.ac.uk

² Department of Pharmacy and Pharmacology, University of Bath, Bath BA1 1RL, UK; V.A.Flower@bath.ac.uk (V.A.F.); j.d.pauling@bath.ac.uk (J.D.P.)

* Correspondence: shaney.barratt@bristol.ac.uk; Tel.: +44-0117-414-6451

Received: 12 March 2018; Accepted: 18 April 2018; Published: 24 April 2018



Abstract: Interstitial lung disease (ILD) encompasses a group of heterogeneous diseases characterised by varying degrees of aberrant inflammation and fibrosis of the lung parenchyma. This may occur in isolation, such as in idiopathic pulmonary fibrosis (IPF) or as part of a wider disease process affecting multiple organs, such as in systemic sclerosis. Anti-Vascular Endothelial Growth Factor (anti-VEGF) therapy is one component of an existing broad-spectrum therapeutic option in IPF (nintedanib) and may become part of the emerging therapeutic strategy for other ILDs in the future. This article describes our current understanding of VEGF biology in normal lung homeostasis and how changes in its bioavailability may contribute the pathogenesis of ILD. The complexity of VEGF biology is particularly highlighted with an emphasis on the potential non-vascular, non-angiogenic roles for VEGF in the lung, in both health and disease.

Keywords: interstitial lung disease; fibrosis; Vascular Endothelial Growth Factor; VEGF

1. Introduction

The term ‘fibrotic lung disease’ or interstitial lung disease (ILD) encompasses a group of more than 100 heterogeneous diseases characterized by similar clinical and radio-pathological patterns of aberrant inflammation and fibrosis of the lung parenchyma despite a wide variety of potential triggers and prognoses [1]. Accurate diagnosis depends on thorough assessment of potential contributing aetiologies, including drugs, granulomatous disease, occupational or environmental exposures (Hypersensitivity pneumonitis–HP) and connective tissue disorders (CTD), but may occur secondary to an unknown cause and are termed the Idiopathic ILDs. Some of these are potentially reversible, such as acute respiratory distress syndrome (ARDS) whilst others are inexorably progressive such as Idiopathic Pulmonary Fibrosis (IPF).

Whilst the exact pathogenesis of each disease may differ, they are characterised by a pathologic fibrotic-repair mechanism following epithelial and endothelial cell injury with aberrant vascular remodelling, expansion and activation of the lung fibroblast/myofibroblast population with resulting abnormal accumulation of extracellular matrix (ECM) and architectural distortion.

Over the last decade there has been growing interest in the role of Vascular Endothelial Growth Factor (VEGF) in the pathogenesis of ILD, with the development of nintedanib for the treatment of IPF, a novel triple tyrosine kinase inhibitor of VEGF, fibroblast derived growth factor (FGF) and platelet derived growth factor (PDGF) receptors [2].

This review describes our current understanding of VEGF biology, highlighting its potential role in normal lung homeostasis and in ILD pathogenesis, with a particular focus in ARDS, IPF, HP and CTD-ILD.

A detailed account of recent advances in VEGF signaling is beyond the scope of this review and is provided elsewhere within this themed collection. Nonetheless, we shall briefly report VEGF biology with respect to its relationship with lung homeostasis and disease. Whilst not systematic in nature, we shall draw on a number of sources, including preclinical mechanistic studies, clinical research and clinical trial data.

2. VEGF Biology

2.1. VEGF Isoforms

VEGF-A is a 34–46 kDa glycoprotein that belongs to a superfamily of structurally and functionally related proteins that includes VEGF-B, VEGF-C, VEGF-D, VEGF-E and placental growth factor (PlGF) [3]. Whilst VEGF-A was originally described as a key regulator of angiogenesis [3,4], there has been significant evolution of the understanding of VEGF biology over the last three decades such that the initial description can be considered as a misnomer; VEGF has been identified in nematode species who lack any vasculature [5], and expression or targeted function is not specific to endothelial cells [6,7].

The *VEGF-A* gene consists of 8 exons separated by 7 introns. Differential splicing of VEGF-A mRNA from exons 5 to 8 generates six known human isoforms, collectively termed the VEGF-A_{xxx}a isoforms: VEGF-A₁₂₁a, VEGF-A₁₄₅a, VEGF-A₁₆₅a, VEGF-A₁₈₃a, VEGF-A₁₈₉a and VEGF-A₂₀₆a, where the subscript denotes the number of amino acids (Figure 1) [3]. VEGF-A₁₆₅a is considered to be most abundant of these isoforms, functioning through tyrosine kinase receptors VEGF receptor 1 (VEGFR1) and receptor 2 (VEGFR2) and co-receptors Neuropilin 1 (NP1) and (NP2).

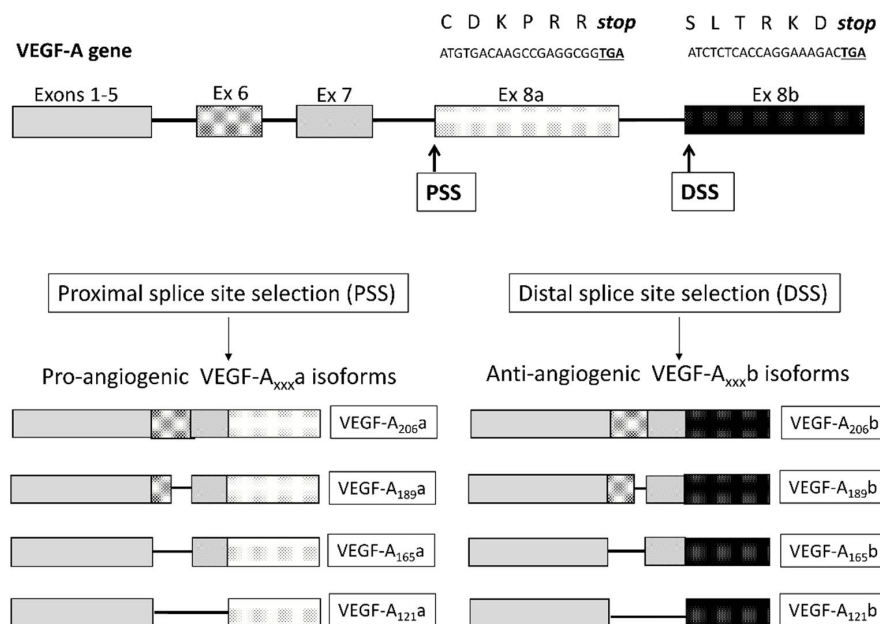

Figure 1. Schematic diagram of the exonic structure of the *Vascular Endothelial Growth Factor-A* (*VEGF-A*) gene and its splice isoforms. The *VEGF-A* gene consists of 8 exons separated by 7 introns. Two alternative exon 8 splice sites exist. Differential splicing of VEGF-A mRNA from exons 5 to 8, with proximal splice site (PSS) selection in exon 8 (Ex8a) generates human isoforms, collectively termed the VEGF-A_{xxx}a isoforms: including VEGF-A₁₂₁a, VEGF-A₁₆₅a, VEGF-A₁₈₉a and VEGF-A₂₀₆a, where the subscript denotes the number of amino acids. Distal splice site selection (DSS) produces a second family of isoforms, the VEGF-A_{xxx}b proteins which have the same number of amino acids as the conventional VEGF-A_{xxx}a isoforms but have an alternative amino acid sequence at their carboxy-terminal (C-terminal) domain: Ser-Leu-Thr-Arg-Lys-Asp (SLTRKD) instead of Cys-Asp-Lys-Pro-Arg-Arg (CDKPRR) in VEGF-A_{xxx}a isoforms. TGA represents the stop codon (*stop*).

Differential splicing of the VEGF gene at the distal splice site with exon 8; 66 bp distal to the VEGF-A_{xxx}a acceptor-site, produces a second family of isoforms, the VEGF-A_{xxx}b proteins which have the same number of amino acids as the conventional VEGF-A_{xxx}a isoforms but have an alternative amino acid sequence at their carboxy-terminal (C-terminal) domain: Ser-Leu-Thr-Arg-Lys-Asp (SLTRKD) instead of Cys-Asp-Lys-Pro-Arg-Arg (CDKPRR) in VEGF-A_{xxx}a isoforms (Figure 1) [8]. The most widely studied of these isoforms, VEGF-A_{165b}, has been shown to act as an inhibitor of VEGF-A_{165a} [8,9] through competitive interference with the VEGFR2-NP1 complex and activation of different downstream receptor phosphorylation sites [10]. Because of sequence homology between these isoform families, a precise, isoform-specific methodology is required to differentiate between them [11].

VEGF-A is the most widely studied molecule of the VEGF superfamily, but it may form heterodimer complexes with other family members to activate VEGF receptors [12] and modulate downstream signalling [13]. VEGF-B is particularly abundant in the heart and skeletal muscle [14] and may contribute to the pulmonary vascular remodelling occurring in response to chronic hypoxia exposure [15]. VEGF-C and VEGF-D are key mediators of lymphangiogenesis [16,17]. VEGF-E is an Orf virus-encoded VEGF homologue which although not present in the human genome binds specifically to VEGFR2 [18]. In normal tissues, PlGF is present most abundantly in the placenta, thyroid and lungs, although its exact role in these tissues remains unclear [19]. When PlGF is produced in the same population of cells with VEGF, it can act as a natural occurring competitive inhibitor [20,21].

2.2. VEGF Receptors

VEGFR2 (also known as kinase domain region (KDR) or fetal liver kinase-1 (FLK-1)) is considered by many as the main signalling receptor for VEGF bioactivity [22,23]. It is abundantly expressed in the vascular bed where it appears to be critical for normal development [24], but several non-endothelial cells (non-ECs), including lung macrophages [3] and alveolar epithelial type II (ATII) cells [25] have also been shown to express VEGFR2.

VEGFR1 (or Flt-1 (Fms-like tyrosine kinase 1) in the mouse) is a 180–185 kDa glycoprotein [26], which also exists as an alternatively spliced soluble isoform (sFlt). Like VEGFR2, VEGFR1 is expressed in high levels throughout development and in adulthood within the vascular bed and is also expressed by several non-ECs, including in lung macrophages, monocytes [27] and ATII cells [28,29]. The exact roles of both VEGFR1 and sFlt are not fully understood, although an abundance of evidence indicates that they function as ‘decoy’ receptors, sequestering VEGF, thus limiting its availability to bind to VEGFR2 [30,31]. Several studies dispute this however, directly implicating it in the regulation of EC migration [32] and survival [33].

NP1 and NP2 are transmembrane glycoproteins, which notably have a short cytoplasmic domain and as such are thought to transduce functional responses only when co-expressed with other receptors [34,35]. Contrasting evidence exists, however, suggesting that NP1 is able to support VEGF-induced cellular signalling independent of VEGFR2 [36] and may have an independent role in the maintenance of normal lung structure [37].

2.3. VEGF and the Lung

In utero, the alveoli, airways and pulmonary vasculature all develop in synchrony [38]. Airway epithelial cells are the predominant source of VEGF-A throughout lung organogenesis [39] and it appears to be crucial for normal alveolarisation, rapid alveolar multiplication during lung maturation [40,41] and normal development of the vascular bed [42]. VEGF-B, VEGF-C, VEGF-D and PlGF are also thought to play a role in physiological lung development but have not been widely studied [43–46].

Following birth, the human lung continues to undergo a period of maturation with rapid alveolar multiplication up to the age of 2 years [47]. Several animal studies also implicate VEGF-A as a crucial factor in this process [42,48,49].

Significant amounts of VEGF-A persist in the normal adult lung, where again the alveolar epithelium [28,50–52] appears to be the prominent source, although smooth muscle cells, macrophages,

ECs and fibroblasts [52] also express VEGF-A [53,54]. Recently it has been shown that this VEGF-A represents both VEGF-A_{xxx}a and VEGF-A_{xxx}b isoforms [52]. Likewise, VEGF receptors and co-receptors are also expressed by several cell types within the normal lung, on both sides of the alveolar capillary membrane (ACM) including ATII cells [25,28,29,55], ECs [24,56,57], macrophages [3,27] and fibroblasts [52].

The classical processes linked to VEGF-A activity (permeability, angiogenesis and mitogenesis) are extremely limited in the mature lung. Thus, whilst the exact role of VEGF-A in the lung has not been fully defined, it has been proposed that compartmentalisation of VEGF-A within the alveolar space, by way of an intact ACM [51,58], is imperative for maintaining normal lung structure and function. ACM disruption is considered part of the disease pathogenesis of ARDS, IPF, HP and systemic sclerosis (SSc), albeit by potentially differing mechanisms, which supports this theory. Each mechanism will be discussed in more detail in the relevant sections.

VEGF-A has been observed to stimulate ATII growth [59,60], surfactant production [61] and angiogenesis of the systemic vasculature [4] with reports suggesting an additional anti-apoptotic and survival role for epithelial [62–64] and ECs [65–67], as such a role for VEGF-A in lung repair following injury has been proposed. Both VEGF-A blockade [42,68–70] and VEGF-A overexpression [71] have been reported to result in an emphysema phenotype in pre-clinical models, suggesting tight regulation of VEGF-A expression as part of lung homeostasis, whilst others have observed the development of pulmonary oedema secondary to VEGF-A overexpression [72]. The role of other VEGF family members in lung homeostasis is not well defined, although PlGF overexpression in pre-clinical animal models also appears to induce emphysematous change [73].

3. VEGF in ARDS

ARDS is a form of diffuse lung injury characterised by the onset of refractory hypoxaemia associated with bilateral lung infiltrates that are not associated with cardiac failure or fluid overload and occur following trigger insult [74]. Damage to the ACM is central to disease pathogenesis, with resulting increased vascular permeability and accompanied inflammatory cell migration and proteinaceous fluid exudation into the lung parenchyma (exudative phase) [75]. Recovery from ARDS is thought to require repair of the ACM through a co-ordinated process of ATII cell proliferation with resorption of the oedema and clearance of proteinaceous material. Whilst the changes associated with ARDS may fully resolve, a proportion of patients heal by fibrin deposition and the development of pulmonary fibrosis (fibroproliferative response) [76], but the factors determining this are not completely understood.

As a potent angiogenic and permeability factor, which is thought to be critical for the structure and maintenance of the normal lung, VEGF-A has been proposed as a key factor in the pathogenesis of this disease [58,76]. VEGF polymorphisms have been associated with both increased severity of and mortality from ARDS [77–79], suggesting that genetic factors may have a role.

Several studies support that VEGF-A contributes as a protective factor against ARDS [80], with observations of reduced bronchoalveolar lavage fluid (BALF) and increased plasma VEGF-A in early ARDS and normalisation in recovery [81–83]. Expression of ATII-derived VEGF-A is increased during recovery from experimental lung injury, implicating VEGF-A in the ACM repair process [84]. Furthermore, the overexpression of VEGF-A₁₆₅a in distal lung epithelial cells confers cytoprotection against experimental hyperoxic lung injury, in part mediated through the production of anti-apoptotic proteins [85].

In contrast, others have suggested a pathological role for VEGF-A in ARDS with the development of pulmonary oedema and increased capillary permeability following adenoviral delivery of VEGF-A₁₆₅a into the trachea of mice, an effect mitigated by anti-VEGF-A therapy [86,87]. Whilst methodological diversity might explain these apparently contrasting findings, we also proposed that the identification of VEGF-A_{xxx}a and VEGF-A_{xxx}b isoforms, with seemingly opposing effects both in vitro and in vivo, may also provide an alternative explanation [78]. In vitro, VEGF-A₁₆₅b was found

to inhibit the proliferative effect of VEGF-A_{165a} on human primary ECs and ATII cells, with reduced expression of VEGF-A_{165b} in ARDS compared to the normal lung, suggesting a role for VEGF-A_{xxx}b in the repair of the ACM following lung injury [60].

The contribution of VEGF-A to the fibro-proliferative phase of ARDS has not been specifically addressed, as far as the authors are aware, although several studies have established a role for VEGF-A in the development of IPF, and these are discussed separately in this article.

A planned phase 2 clinical trial studying the efficacy of the anti-VEGF monoclonal antibody bevacizumab in preventing ARDS (NCT01314066) was recently withdrawn, prior to enrolment, due to inadequate funding. As such, there are no disease modifying therapies currently available for ARDS and supportive care, and lung protective ventilator strategies remain the mainstay of treatment.

4. VEGF in IPF

IPF is the most common of the idiopathic ILDs associated with high mortality; estimated as greater than 50 per 1,000,000 persons [88,89] and an estimated mean survival of only 2–5 years from diagnosis [90,91]. Best supportive care for these patients includes consideration of pharmacological options such as pirfenidone [92] and the triple tyrosine kinase inhibitor (VEGF, FGF and PDGF) nintedanib [2], which attempt to slow disease progression with both pharmacological and non-pharmacological interventions to palliate symptoms.

The pathogenesis of IPF remains poorly understood, although alveolar epithelial cell injury [1,93] with disruption of ACM integrity alongside abnormal vascular repair and remodelling, have been proposed as possible pathogenic mechanisms [94–96]. Ultimately, the formation of collections of fibroblasts and activated myofibroblasts (fibroblastic foci) appear to be at the leading edge of this disease [97], producing the exaggerated extracellular matrix (ECM) deposit that contributes to the disruption of normal lung architecture.

The relationship of VEGF-A expression in IPF remains controversial and appears to differ according to the compartment sampled. Several groups have observed reduced VEGF-A in the BALF of IPF patients compared to controls [52,94,98–100], whilst others have reported unchanged levels [101]. Similarly, VEGF-A in lung homogenates are reduced [101] or unchanged [52,94] in IPF. Equally, there are contrasting reports as to the trend of circulating VEGF-A levels in IPF patients relative to the severity and progression of the disease [52,99,101,102].

As a potent angiogenic factor, interest arose into whether VEGF-A may contribute to the vascular remodelling process [95,103]. Minimal VEGF-A expression has been demonstrated within the fibrotic focus itself [52,94], but is expressed in abundance in the surrounding tissue [52]. Increased alveolar capillary density in non-fibrotic regions of the IPF lung has also been associated with the expression of VEGF-A and other potent angiogenic mediators by ATII cells in close proximity to these capillaries [95]. The primary vascular abnormality in IPF, be it a lack or excess of neovascularisation is still unknown, and equally, the role of increased vascularisation in the least fibrotic regions has not been defined [38,104,105]. Given that VEGF-A potentially plays a role in normal lung maintenance and repair, it has been hypothesised that in relatively normal areas of the IPF lung, VEGF-A released from ATII cells may play a role in alveolar wall protection, contributing to the regeneration of wall defects; with locally increased vascularity occurring as part of the attempted repair process [105]. Several studies support this hypothesis, suggesting a protective role for VEGF-A against the formation of pulmonary fibrosis [101,106,107] and Murray et al. [101] have recently proposed that this epithelial-protective function of VEGF-A may occur via a non-cell autonomous function mediated by the endothelium.

Fehrenbach et al. [25] were amongst the first groups to suggest that VEGF-A may have a wider part to play in the development of pulmonary fibrosis, rather than only on the vasculature, by demonstrating a marked increase in VEGF-A positive stained cells in the absence of increased vascularisation in the fibrotic regions in a preclinical model of pulmonary fibrosis (Bleomycin (BLM)-induced pulmonary fibrosis). Subsequently, Hamada et al. [108] proposed that VEGF-A might facilitate fibrogenesis. Transfection of anti-VEGF gene therapy, in the form of the sFlt-1, resulted in the attenuation of

pulmonary fibrosis with a reduction in lung collagen deposition and additional anti-inflammatory and anti-angiogenic effects. Furthermore, Chaudhary et al. [109] demonstrated that BIBF 1000, a novel tyrosine kinase inhibitor of PDGF, FGF and VEGF, attenuated BLM-induced pulmonary fibrosis in rats, as measured by a reduction in collagen deposition and the inhibition of pro-fibrotic gene expression. This compound is now available clinically as Nintedanib and has been approved for the treatment of IPF based on the results of twin Phase III INPULSIS-1 and -2 trials [2].

Therefore, as was the case for ARDS, results from the currently available evidence suggests potentially conflicting roles for VEGF-A as both a protective and contributory factor in the development of IPF. Interestingly, in pre-clinical studies, the concomitant adenoviral delivery of TGF- β 1 and VEGF-A_{165a} results in exaggerated pulmonary fibrosis, but attenuation of pulmonary artery remodelling and pulmonary hypertension, compared to TGF- β 1 alone [110], highlighting the complicated role that VEGF-A may play in the lung, with potentially opposing effects of VEGF-A in different lung compartments existing concurrently.

An alternative explanation for the apparently contradicting data regarding the role of VEGF-A in IPF has recently been proposed. The co-ordinated expression of VEGF-A_{xxx}a and VEGF-A_{xxx}b isoforms are important for the development of pulmonary fibrosis both in vitro and in pre-clinical murine models [52]. In this study, ATII cell-derived VEGF-A_{xxx}a was critical for the development of fibrosis in a preclinical model of fibrosis, with an inhibitory/regulatory function for VEGF-A_{xxx}b isoforms. Furthermore, VEGF_{165a} and VEGF-A_{165b} had differential effects on fibroblast proliferation, migration and ECM production in vitro. Up-regulation of VEGF-A_{165b} within the IPF lung and in patients who progressed after 1 year follow-up (Forced Vital Capacity (FVC) fall of $\geq 10\%$ or death), suggests that the VEGF-A_{xxx}b may be released as a compensatory protective mechanism against fibrogenesis, overwhelmed by other processes occurring within the lung.

5. VEGF in Hypersensitivity Pneumonitis (HP)

HP is an interstitial lung disease characterised by inflammation and/or fibrosis in susceptible individuals following repeated inhalation of environmental antigens. As only a small proportion of individuals exposed to a particular antigen develop the disease, paradigms suggest a two-hit hypothesis with an additional genetic predisposition [111]. A clinical spectrum of disease exists with acute presentations thought to be mediated through immune complexes, as suggested by lung neutrophilia and high titres of antigen-specific serum IgGs, whilst sub-acute and chronic presentations are characterised by a T-cell-mediated immune response [112].

Progressive fibrosis may ensue, if responsible antigens are not identified and continued exposure occurs, with associated excessive extracellular matrix deposition and the destruction of normal lung architecture. The processes driving this are less well understood, although differences in gene expression profiling [113], BALF cellular content and cytokine expression between IPF and HP suggests mechanistic divergence in the pathogenesis of fibrosis between these two conditions [114,115]. That said, the upregulation of the markers of alveolar epithelial apoptosis in human lung sections from patients with HP [116] suggests that alveolar epithelial cell integrity is again important in the disease process.

Very few studies have examined a potential role for VEGF-A in HP. In the small cohorts examined thus far, analogous to ARDS and IPF, BALF VEGF-A levels are reduced in patients with HP [115,117]. In contrast, serum VEGF-A levels appear increased compared to controls [117,118] and IPF patients [118].

The function of the lymphatic system is primarily to transport antigens and antigen-presenting cells from the peripheral tissues to lymph nodes to stimulate an immune response [119]. Lymphangiogenesis occurs in various pathological conditions, including during inflammation and wound healing. As key mediators of lymphangiogenesis, a role for VEGF-C and VEGF-D in the development of HP has thus been proposed. In a small cohort of acute and subacute HP patients, BALF VEGF-C and VEGF-D levels were elevated compared to healthy controls, with increased levels of VEGF-D but not VEGF-C compared to IPF patients. Furthermore, VEGF-D levels correlated with

HP inflammatory severity as determined by BALF lymphocytosis [118]. Further work is required to explore this apparent association.

6. VEGF-A in Autoimmune Rheumatic Diseases

Dysregulated tissue remodeling with aberrant fibrosis is one of the pathological hallmarks of the autoimmune rheumatic diseases and ILD is an important cause of disease-related morbidity across this group of disorders, particularly within connective tissue diseases (CTD) such as SSc [120].

6.1. SSc

SSc is a multisystem disease characterised by a triad of autoimmunity, vasculopathy and aberrant tissue remodeling resulting in varying degrees of tissue fibrosis [121,122]. SSc-ILD is the leading cause of disease-related mortality [123]. Endothelial injury is an important initiating pathological event [124–126] and clinical manifestations of vasculopathy (characteristic nailfold capillary changes and Raynaud's phenomenon) pre-date the development of tissue fibrosis [127]. The evolving obliterative microangiopathy characterized by progressive capillary loss (that can be directly visualized at the nailfold) results in progressive tissue ischaemia, which could be an important driver of both ischaemic complications such as digital ulcers but also tissue fibrosis [128,129].

The induction of VEGF pathways by hypoxia [130] has led to interest in its potential role in the pathogenesis of SSc. Early studies demonstrated raised circulating levels of VEGF-A in both early [131] and more established SSc [132]; surprising given the progressive capillary loss in SSc. Subsequent work examining VEGF-A splice isoforms provided a plausible explanation, having identified increased plasma levels of the VEGF-A_{165b} splice variant in association with more severe nailfold capillary loss [133]. It is possible that isoform switching from pro-angiogenic VEGF-A_{xxx}a isoform production in early disease to inhibitory VEGF-A_{xxx}b isoforms might help explain disease evolution in this heterogeneous disease, although the mechanisms leading to isoform switching have yet to be elucidated. With regards to SSc-ILD, there are lower VEGF-A BALF levels in SSc compared to both healthy controls and SSc patients without lung involvement [134]. De Santis et al. observed a direct correlation between circulating VEGF-A and increased severity of ILD, as determined by the extent of interstitial abnormalities on CT imaging and lung function parameters, suggesting a possible pathological role for VEGF-A in SSc-ILD [135]. The anti-angiogenic VEGF-A_{165b} isoform has yet to be fully investigated in SSc-related pulmonary disease. Nintedanib has recently been shown to ameliorate histological features of pulmonary arterial hypertension (PAH) and pulmonary fibrosis in pre-clinical models of SSc, which has encouraging implications for ongoing phase III clinical trials of nintedanib in SSc-associated ILD [136].

6.2. Other Forms of CTD-ILD

Both VEGF-A and anti-angiogenic VEGF-A_{165b} isoforms are over-expressed in muscle tissue from patients with myositis-spectrum disorders (MSD) compared to healthy donors [137,138]. However, there is limited data on circulating VEGF-A levels and pulmonary disease in MSD [139]. The only work examining VEGF in systemic lupus erythematosus (SLE)-related lung disease has focused on PAH, identifying higher levels of VEGF-A in SLE patients with PAH compared to those without [140]. Similar results were found in PAH related to mixed connective tissue disease [141]. Microscopic polyangiitis (MPA) is a systemic small vessel vasculitis with pulmonary involvement ranging from ILD, nodularity, consolidation and pleural effusions. Serum VEGF-A is increased in MPA patients (with lung involvement) and falls in response to systemic immunosuppression, perhaps because inflammatory cells such as macrophages are an important source [142].

6.3. Inflammatory Arthritis

Rheumatoid arthritis (RA) is common (prevalence ~1%), but clinically meaningful RA-associated ILD is rare. Circulating VEGF-A is increased in RA patients, particularly in those patients with extra-articular manifestations (including pulmonary fibrosis) [143,144].

7. Summary

Significant quantities of VEGF-A exist in the normal lung. Processes classically associated with VEGF-A (angiogenesis, mitogenesis and permeability) are extremely restricted, however, suggesting an alternative role for VEGF-A in the mature lung. Growing evidence suggests that this role involves the maintenance of normal lung structure and function, where an intact ACM and thus compartmentalisation of VEGF-A appears crucial.

There are apparent disparities in the literature regarding VEGF-A in lung disease, which may be in part due to methodological differences in the study design and animal models used. It is possible that regional or compartmental differences in VEGF-A expression in the lung or heterogeneity within and between the individuals studied may also account for the differences observed. The presence of and differential influence of VEGF-A splice variants offers an alternative explanation (Figure 2).

Fibrotic Interstitial lung disease

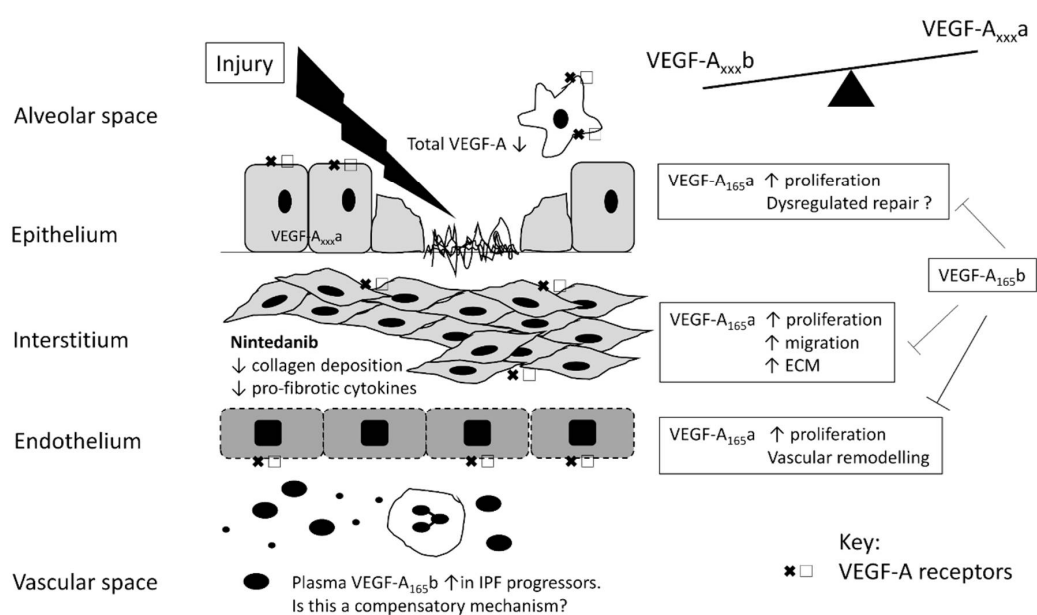

Figure 2. Schematic diagram of the role of VEGF-A in the development of fibrotic interstitial lung disease. Current paradigms suggest repeated alveolar epithelial cell injury is an important initiating factor. VEGF-A receptors are abundantly expressed on both sides of the alveolar capillary membrane; alveolar epithelial type II (AII) cells [25,28,29,55], macrophages [3,27], in the vascular bed [24,56,57] and by fibroblasts [52]. Total VEGF-A levels are consistently reduced in the bronchoalveolar lavage fluid of patients with fibrotic lung disease. Nintedanib is a tyrosine kinase inhibitor of VEGF-A receptor activity [2] (thus theoretically inhibiting VEGF-A_{xxx}a and VEGF-A_{xxx}b isoforms) with clinical application in the treatment of idiopathic pulmonary fibrosis (IPF) [2]. AII cell derived VEGF-A_{xxx}a appears critical for the development of pulmonary fibrosis in pre-clinical models, with VEGF-A₁₆₅b having an inhibitory/opposing effect [52]. In vitro, VEGF-A₁₆₅a has been shown to induce the proliferation of AII cells [60], endothelial cells [60] and fibroblasts [52], and increase extracellular matrix production by fibroblasts [52], all inhibited by VEGF-A₁₆₅b. Taken in conjunction with the data from pre-clinical models it suggests that the co-ordinated expression of VEGF-A_{xxx}a:VEGF-A_{xxx}b appears important in health and disease, with VEGF-A_{xxx}a acting as a driver of the fibrotic process. Upregulation of circulating VEGF-A₁₆₅b levels in IPF patients who subsequently progressed after 1 year follow-up (FVC fall of $\geq 10\%$ or death), suggests that VEGF-A_{xxx}b may be released as a compensatory protective mechanism against fibrogenesis, overwhelmed by other processes occurring within the lung [52].

The complexity of VEGF biology in lung disease is becoming increasingly apparent, not to mention the numerous physiological roles of VEGF in several organ systems and the potential for pleiotropic effects [145,146]. The development of future therapies directed at VEGF requires consideration of these factors with detailed characterisation of patient phenotypes to enable superior targeted therapy.

Author Contributions: Shaney L. Barratt conceived the idea for this manuscript. All authors (Shaney L. Barratt, Victoria A. Flower, John D. Pauling and Ann B. Millar) contributed to the writing of the manuscript equally.

Conflicts of Interest: The authors declare no conflict of interest.

References

1. American Thoracic Society; European Respiratory Society. American Thoracic Society/European Respiratory Society International Multidisciplinary Consensus Classification of the Idiopathic Interstitial Pneumonias. This joint statement of the American Thoracic Society (ATS), and the European Respiratory Society (ERS) was adopted by the ATS board of directors, June 2001 and by the ERS Executive Committee, June 2001. *Am. J. Respir. Crit. Care Med.* **2001**, *165*, 277–304.
2. Richeldi, L.; du Bois, R.M.; Raghu, G.; Azuma, A.; Brown, K.; Costabel, U.; Cottin, V.; Flaherty, K.R.; Hansell, D.M.; Yoshikazu, I.; et al. Efficacy and safety of nintedanib in idiopathic pulmonary fibrosis. *N. Engl. J. Med.* **2014**, *370*, 2071–2082. [[CrossRef](#)] [[PubMed](#)]
3. Ferrara, N.; Gerger, H.P.; Lecouter, J. The biology of VEGF and its receptors. *Nat. Med.* **2003**, *9*, 669–676. [[CrossRef](#)] [[PubMed](#)]
4. Leung, D.W.; Cachianes, G.; Kuang, W.J.; Goeddel, D.V.; Ferrara, N. Vascular endothelial growth factor is a secreted angiogenic mitogen. *Science* **1989**, *246*, 1306–1309. [[CrossRef](#)] [[PubMed](#)]
5. Zacchigna, S.; Lambrechts, D.; Carmeliet, P. Neurovascular signaling defects in neurodegeneration. *Nat. Rev. Neurosci.* **2008**, *9*, 169–181. [[CrossRef](#)] [[PubMed](#)]
6. Harper, S.J.; Bates, D.O. VEGF-A splicing: The key to anti-angiogenic therapeutics? *Nat. Rev. Cancer* **2008**, *8*, 880–887. [[CrossRef](#)] [[PubMed](#)]
7. Bates, D.O. Vascular endothelial growth factors and vascular permeability. *Cardiovasc. Res.* **2010**, *87*, 262–271. [[CrossRef](#)] [[PubMed](#)]
8. Bates, D.O.; Cui, T.G.; Doughty, J.M.; Winkler, M.; Sugiono, M.; Shields, J.D.; Peat, D.; Gillatt, D.; Harper, S.J. VEGF165b, an inhibitory splice variant of vascular endothelial growth factor, is down-regulated in renal cell carcinoma. *Cancer Res.* **2002**, *62*, 4123–4131. [[PubMed](#)]
9. Woolard, J.; Wang, W.Y.; Bevan, H.S.; Qiu, Y.; Morbidelli, L.; Pritchard-Jones, R.O.; Cui, T.G.; Sugiono, M.; Waive, E.; Perrin, R.; et al. VEGF165b, an inhibitory vascular endothelial growth factor splice variant: Mechanism of action, in vivo effect on angiogenesis and endogenous protein expression. *Cancer Res.* **2004**, *64*, 7822–7835. [[CrossRef](#)] [[PubMed](#)]
10. Cebe Suarez, S.; Pieren, M.; Cariolato, L.; Arn, S.; Hoffmann, U.; Bogucki, A.; Manlius, C.; Wood, J.; Ballmer-Hofer, K. A VEGF-A splice variant defective for heparan sulfate and neuropilin-1 binding shows attenuated signaling through VEGFR-2. *Cell. Mol. Life Sci.* **2006**, *63*, 2067–2077. [[CrossRef](#)] [[PubMed](#)]
11. Bates, D.O.; Qiu, Y.; Cater, J.G.; Hamdollah-Zadeh, M.; Barratt, S.; Gammons, M.V.; Millar, A.B.; Salmon, A.H.J.; Oltean, S.; Haeper, S.J. Detection of VEGF-A(xxx)b isoforms in human tissues. *PLoS ONE* **2013**, *8*, e68399. [[CrossRef](#)] [[PubMed](#)]
12. Olofsson, B.; Korpelainen, E.; Pepper, M.S.; Mandriota, S.J.; Aase, K.; Kumar, V.; Gunji, Y.; Jeltsch, M.M.; Shibuya, M.; Alitalo, K.; et al. Vascular endothelial growth factor B (VEGF-B) binds to VEGF receptor-1 and regulates plasminogen activator activity in endothelial cells. *Proc. Natl. Acad. Sci. USA* **1998**, *95*, 11709–11714. [[CrossRef](#)] [[PubMed](#)]
13. Joukov, V.; Pajusola, K.; Kaipainen, A.; Chilov, D.; Lahtinen, I.; Kukk, E.; Saksela, O.; Kalkkinen, N.; Alitalo, K. A novel vascular endothelial growth factor, VEGF-C, is a ligand for the Flt4 (VEGFR-3) and KDR (VEGFR-2) receptor tyrosine kinases. *EMBO J.* **1996**, *15*, 290–298. [[PubMed](#)]
14. Olofsson, B.; Pajusola, K.; Kaipainen, A.; Von Eular, G.; Joukov, V.; Saksela, O.; Orpana, A.; Pettersson, R.F.; Alitalo, K.; Eriksson, U. Vascular endothelial growth factor B, a novel growth factor for endothelial cells. *Proc. Natl. Acad. Sci. USA* **1996**, *93*, 2576–2581. [[CrossRef](#)] [[PubMed](#)]

15. Wanstall, J.C.; Gambino, A.; Jeffrey, T.K.; Cahill, M.M.; Bellomo, D.; Hayward, N.K.; Kay, G.F. Vascular endothelial growth factor-B-deficient mice show impaired development of hypoxic pulmonary hypertension. *Cardiovasc. Res.* **2002**, *55*, 361–368. [[CrossRef](#)]
16. Wirzenius, M.; Tammela, T.; Uutela, M.; He, Y.; Odorisio, T.; Zambruno, G.; Nagy, J.A.; Dvorak, H.F.; Yla-Herttuala, S.; Shibuya, M.; et al. Distinct vascular endothelial growth factor signals for lymphatic vessel enlargement and sprouting. *J. Exp. Med.* **2007**, *204*, 1431–1440. [[CrossRef](#)] [[PubMed](#)]
17. Saaristo, A.; Veikkola, T.; Enholm, B.; Hytonen, M.; Arola, J.; Pajusola, K.; Turunen, P.; Jeltsch, M.; Karkkainen, M.J.; Kerjaschki, D.; et al. Adenoviral VEGF-C overexpression induces blood vessel enlargement, tortuosity, and leakiness but no sprouting angiogenesis in the skin or mucous membranes. *FASEB J.* **2002**, *16*, 1041–1049. [[CrossRef](#)] [[PubMed](#)]
18. Ogawa, S.; Oku, A.; Sawano, A.; Yamaguchi, S.; Yazaki, Y.; Shibuya, M. A novel type of vascular endothelial growth factor, VEGF-E (NZ-7 VEGF), preferentially utilizes KDR/Flk-1 receptor and carries a potent mitotic activity without heparin-binding domain. *J. Biol. Chem.* **1998**, *273*, 31273–31282. [[CrossRef](#)] [[PubMed](#)]
19. DiPalma, T.; Tucci, M.; Russo, G.; Maglione, D.; Lago, C.T.; Romano, A.; Saccone, S.; Della Valle, G.; De Gregorio, L.; Dragani, T.A.; et al. The placenta growth factor gene of the mouse. *Mamm. Genome* **1996**, *7*, 6–12. [[CrossRef](#)] [[PubMed](#)]
20. Cao, Y. Positive and negative modulation of angiogenesis by VEGFR1 ligands. *Sci. Signal.* **2009**, *2*. [[CrossRef](#)] [[PubMed](#)]
21. Eriksson, A.; Cao, R.; Pawliuk, R.; Berg, S.M.; Tsang, M.; Zhou, D.; Fleet, C.; Tritsarlis, K.; Dissing, S.; Le Boulch, P.; et al. Placenta growth factor-1 antagonizes VEGF-induced angiogenesis and tumor growth by the formation of functionally inactive PlGF-1/VEGF heterodimers. *Cancer Cell* **2002**, *1*, 99–108. [[CrossRef](#)]
22. Carmeliet, P.; Moons, L.; Luttun, A.; Vincenti, V.; Compernelle, V.; De Mol, M.; Wu, Y.; Bono, F.; Devy, L.; Beck, H.; et al. Synergism between vascular endothelial growth factor and placental growth factor contributes to angiogenesis and plasma extravasation in pathological conditions. *Nat. Med.* **2001**, *7*, 575–583. [[CrossRef](#)] [[PubMed](#)]
23. Matsumoto, T.; Claesson-Welsh, L. VEGF receptor signal transduction. *Sci. STKE* **2001**, *2001*. [[CrossRef](#)] [[PubMed](#)]
24. Shalaby, F.; Rossant, J.; Yamaguchi, T.P.; Gertsenstein, M.; Wu, X.F.; Breitman, M.L.; Schuh, A.C. Failure of blood-island formation and vasculogenesis in Flk-1-deficient mice. *Nature* **1995**, *376*, 62–66. [[CrossRef](#)] [[PubMed](#)]
25. Fehrenbach, H.; Kasper, M.; Haase, M.; Schuh, D.; Muller, M. Differential immunolocalization of VEGF in rat and human adult lung, and in experimental rat lung fibrosis: Light, fluorescence, and electron microscopy. *Anat. Rec.* **1999**, *254*, 61–73. [[CrossRef](#)]
26. De Vries, C.; Escobedo, J.A.; Ueno, H.; Houck, K.; Ferrara, N.; Williams, L.T. The fms-like tyrosine kinase, a receptor for vascular endothelial growth factor. *Science* **1992**, *255*, 989–991. [[CrossRef](#)] [[PubMed](#)]
27. Sawano, A.; Iwai, S.; Sakurai, Y.; Ito, M.; Shitara, K.; Nakahata, T.; Shibuya, M. Flt-1, vascular endothelial growth factor receptor 1, is a novel cell surface marker for the lineage of monocyte-macrophages in humans. *Blood* **2001**, *97*, 785–791. [[CrossRef](#)] [[PubMed](#)]
28. Maniscalco, W.M.; Watkins, R.H.; D'Angio, C.T.; Ryan, R.M. Hyperoxic injury decreases alveolar epithelial cell expression of vascular endothelial growth factor (VEGF) in neonatal rabbit lung. *Am. J. Respir. Cell Mol. Biol.* **1997**, *16*, 557–567. [[CrossRef](#)] [[PubMed](#)]
29. Medford, A.R.; Douglas, S.K.; Godinho, S.I.; Uppington, K.M.; Armstrong, L.; Gillespie, K.M.; Van Zyl, B.; Tetley, T.D.; Ibrahim, N.B.; Millar, A.B. Vascular Endothelial Growth Factor (VEGF) isoform expression and activity in human and murine lung injury. *Respir. Res.* **2009**, *10*, 27. [[CrossRef](#)] [[PubMed](#)]
30. Waltenberger, J.; Claesson-Welsh, L.; Siegbahn, A.; Shibuya, M.; Heldin, C.H. Different signal transduction properties of KDR and Flt1, two receptors for vascular endothelial growth factor. *J. Biol. Chem.* **1994**, *269*, 26988–26995. [[PubMed](#)]
31. Kendall, R.L.; Thomas, K.A. Inhibition of vascular endothelial cell growth factor activity by an endogenously encoded soluble receptor. *Proc. Natl. Acad. Sci. USA* **1993**, *90*, 10705–10709. [[CrossRef](#)] [[PubMed](#)]
32. Kanno, S.; Oda, N.; Abe, M.; Terai, Y.; Ito, M.; Shitara, K.; Tabayashi, K.; Shibuya, M.; Sato, Y. Roles of two VEGF receptors, Flt-1 and KDR, in the signal transduction of VEGF effects in human vascular endothelial cells. *Oncogene* **2000**, *19*, 2138–2146. [[CrossRef](#)] [[PubMed](#)]

33. Zhang, F.; Tang, Z.; Hou, X.; Lennartsson, J.; Li, Y.; Koch, A.W.; Scotney, P.; Lee, C.; Arjunan, P.; Dong, L.; et al. VEGF-B is dispensable for blood vessel growth but critical for their survival, and VEGF-B targeting inhibits pathological angiogenesis. *Proc. Natl. Acad. Sci. USA* **2009**, *106*, 6152–6157. [[CrossRef](#)] [[PubMed](#)]
34. Neufeld, G.; Cohen, T.; Gengrinovitch, S.; Poltorak, Z. Vascular endothelial growth factor (VEGF) and its receptors. *FASEB J.* **1999**, *13*, 9–22. [[CrossRef](#)] [[PubMed](#)]
35. Grunewald, F.S.; Protá, A.E.; Giese, A.; Ballmer-Hofer, K. Structure-function analysis of VEGF receptor activation and the role of coreceptors in angiogenic signaling. *Biochim. Biophys. Acta* **2010**, *1804*, 567–580. [[CrossRef](#)] [[PubMed](#)]
36. Ishida, A.; Murray, J.; Saito, Y.; Kanthou, C.; Benzakour, O.; Shibuya, M.; Wijelath, E.S. Expression of vascular endothelial growth factor receptors in smooth muscle cells. *J. Cell. Physiol.* **2001**, *188*, 359–368. [[CrossRef](#)] [[PubMed](#)]
37. Le, A.; Zielinski, R.; He, C.; Crow, M.T.; Biswal, S.; Tudor, R.M.; Becker, P.M. Pulmonary epithelial neuropilin-1 deletion enhances development of cigarette smoke-induced emphysema. *Am. J. Respir. Crit. Care Med.* **2009**, *180*, 396–406. [[CrossRef](#)] [[PubMed](#)]
38. Farkas, L.; Gauldie, J.; Voelkel, N.F.; Kolb, M. Pulmonary hypertension and idiopathic pulmonary fibrosis: A tale of angiogenesis, apoptosis, and growth factors. *Am. J. Respir. Cell Mol. Biol.* **2011**, *45*, 1–15. [[CrossRef](#)] [[PubMed](#)]
39. Accrregui, M.J.; Penisten, S.T.; Goss, K.L.; Ramirez, K.; Snyder, J.M. Vascular endothelial growth factor gene expression in human fetal lung in vitro. *Am. J. Respir. Cell Mol. Biol.* **1999**, *20*, 14–23. [[CrossRef](#)] [[PubMed](#)]
40. Ng, Y.S.; Rohan, R.; Sunday, M.E.; Demello, N.G.; D'Amore, P.A. Differential expression of VEGF isoforms in mouse during development and in the adult. *Dev. Dyn.* **2001**, *220*, 112–121. [[CrossRef](#)]
41. Galambos, C.; Ng, Y.S.; Ali, A.; Noguchi, A.; Lovejoy, S.; D'Amore, P.A.; Demello, D.E. Defective pulmonary development in the absence of heparin-binding vascular endothelial growth factor isoforms. *Am. J. Respir. Cell Mol. Biol.* **2002**, *27*, 194–203. [[CrossRef](#)] [[PubMed](#)]
42. Mura, M.; Binnie, M.; Han, B.; Li, C.; Andrade, C.F.; Shiozaki, A.; Zhang, Y.; Ferrara, N.; Hwang, D.; Waddell, T.K.; et al. Functions of type II pneumocyte-derived vascular endothelial growth factor in alveolar structure, acute inflammation, and vascular permeability. *Am. J. Pathol.* **2010**, *176*, 1725–1734. [[CrossRef](#)] [[PubMed](#)]
43. Janer, J.; Lassus, P.; Haglund, C.; Paavonen, K.; Alitalo, K.; Andersson, S. Pulmonary vascular endothelial growth factor-C in development and lung injury in preterm infants. *Am. J. Respir. Crit. Care Med.* **2006**, *174*, 326–330. [[CrossRef](#)] [[PubMed](#)]
44. De Paepe, M.E.; Greco, D.; Mao, Q. Angiogenesis-related gene expression profiling in ventilated preterm human lungs. *Exp. Lung Res.* **2010**, *36*, 399–410. [[CrossRef](#)] [[PubMed](#)]
45. Greenberg, J.M.; Thompson, F.Y.; Brooks, S.K.; Shannon, J.M.; McCormick-Shannon, K.; Cameron, J.E.; Mallory, B.P.; Akeson, A.L. Mesenchymal expression of vascular endothelial growth factors D and A defines vascular patterning in developing lung. *Dev. Dyn.* **2002**, *224*, 144–153. [[CrossRef](#)] [[PubMed](#)]
46. Janer, J.; Andersson, S.; Haglund, C.; Karikoski, R.; Lassus, P. Placental growth factor and vascular endothelial growth factor receptor-2 in human lung development. *Pediatrics* **2008**, *122*, 340–346. [[CrossRef](#)] [[PubMed](#)]
47. Thurlbeck, W.M. Postnatal human lung growth. *Thorax* **1982**, *37*, 564–571. [[CrossRef](#)] [[PubMed](#)]
48. Jakkula, M.; Le Cras, T.D.; Gebb, S.; Hirth, K.P.; Tudor, R.M.; Voelkel, N.F.; Abman, S.H. Inhibition of angiogenesis decreases alveolarization in the developing rat lung. *Am. J. Physiol. Lung Cell. Mol. Physiol.* **2000**, *279*, L600–L607. [[CrossRef](#)] [[PubMed](#)]
49. McGrath-Morrow, S.A.; Cho, C.; Zhen, L.; Hicklin, D.J.; Tudor, R.M. Vascular endothelial growth factor receptor 2 blockade disrupts postnatal lung development. *Am. J. Respir. Cell Mol. Biol.* **2005**, *32*, 420–427. [[CrossRef](#)] [[PubMed](#)]
50. Berse, B.; Brown, L.F.; Van de Water, L.; Dvorak, H.F.; Senger, D.R. Vascular permeability factor (vascular endothelial growth factor) gene is expressed differentially in normal tissues, macrophages, and tumors. *Mol. Biol. Cell* **1992**, *3*, 211–220. [[CrossRef](#)] [[PubMed](#)]
51. Kaner, R.J.; Crystal, R.G. Compartmentalization of vascular endothelial growth factor to the epithelial surface of the human lung. *Mol. Med.* **2001**, *7*, 240–246. [[PubMed](#)]

52. Barratt, S.L.; Blythe, T.; Jarrett, C.; Ourradi, K.; Shelley-Fraser, G.; Day, M.J.; Qiu, Y.; Harper, S.; Maher, T.M.; Oltean, S.; et al. Differential Expression of VEGF-Axxx Isoforms Is Critical for Development of Pulmonary Fibrosis. *Am. J. Respir. Crit. Care Med.* **2017**, *196*, 479–493. [[CrossRef](#)] [[PubMed](#)]
53. Yao, J.S.; Shen, F.; Young, W.L.; Yang, G.Y. Comparison of doxycycline and minocycline in the inhibition of VEGF-induced smooth muscle cell migration. *Neurochem. Int.* **2007**, *50*, 524–530. [[CrossRef](#)] [[PubMed](#)]
54. Wu, W.K.; Llewellyn, O.P.; Bates, D.O.; Nicholson, L.B.; Dick, A.D. IL-10 regulation of macrophage VEGF production is dependent on macrophage polarisation and hypoxia. *Immunobiology* **2010**, *215*, 796–803. [[CrossRef](#)] [[PubMed](#)]
55. Medford, A.R.; Ibrahim, N.B.; Millar, A.B. Vascular endothelial growth factor receptor and coreceptor expression in human acute respiratory distress syndrome. *J. Crit. Care* **2009**, *24*, 236–242. [[CrossRef](#)] [[PubMed](#)]
56. Fujio, Y.; Walsh, K. Akt mediates cytoprotection of endothelial cells by vascular endothelial growth factor in an anchorage-dependent manner. *J. Biol. Chem.* **1999**, *274*, 16349–16354. [[CrossRef](#)] [[PubMed](#)]
57. Soker, S.; Fidler, H.; Neufeld, G.; Klagbrun, M. Characterization of novel vascular endothelial growth factor (VEGF) receptors on tumor cells that bind VEGF165 via its exon 7-encoded domain. *J. Biol. Chem.* **1996**, *271*, 5761–5767. [[CrossRef](#)] [[PubMed](#)]
58. Medford, A.R.; Millar, A.B. Vascular endothelial growth factor (VEGF) in acute lung injury (ALI) and acute respiratory distress syndrome (ARDS): Paradox or paradigm? *Thorax* **2006**, *61*, 621–626. [[CrossRef](#)] [[PubMed](#)]
59. Brown, K.R.; England, K.M.; Goss, K.L.; Snyder, J.M.; Acarregui, M.J. VEGF induces airway epithelial cell proliferation in human fetal lung in vitro. *Am. J. Physiol. Lung Cell. Mol. Physiol.* **2001**, *281*, L1001–L1010. [[CrossRef](#)] [[PubMed](#)]
60. Varet, J.; Douglas, S.K.; Gilmartin, L.; Medford, A.R.; Bates, D.O.; Harper, S.J.; Millar, A.B. VEGF in the lung: A role for novel isoforms. *Am. J. Physiol. Lung Cell. Mol. Physiol.* **2016**, *298*, L768–L774. [[CrossRef](#)] [[PubMed](#)]
61. Compernelle, V.; Brusselmans, K.; Acker, T.; Hoet, P.; Tjwa, M.; Beck, H.; PLaisance, S.; Dor, Y.; Keshet, E.; Lupu, F.; et al. Loss of HIF-2 α and inhibition of VEGF impair fetal lung maturation, whereas treatment with VEGF prevents fatal respiratory distress in premature mice. *Nat. Med.* **2002**, *8*, 702–710. [[CrossRef](#)] [[PubMed](#)]
62. Mura, M.; Han, B.; Andrade, C.F.; Seth, R.; Hwang, D.; Waddell, T.K.; Keshavjee, S.; Liu, M. The early responses of VEGF and its receptors during acute lung injury: Implication of VEGF in alveolar epithelial cell survival. *Crit. Care* **2006**, *10*, R130. [[CrossRef](#)] [[PubMed](#)]
63. Roberts, J.R.; Perkins, G.D.; Fujisawa, T.; Pettigrew, K.A.; Gao, F.; Ahmed, A.; Thickett, D.R. Vascular endothelial growth factor promotes physical wound repair and is anti-apoptotic in primary distal lung epithelial and A549 cells. *Crit. Care Med.* **2007**, *35*, 2164–2170. [[CrossRef](#)] [[PubMed](#)]
64. Kuhn, H.; Kruger, S.; Hammerschmidt, S.; Wirtz, H. High concentrations of vascular endothelial growth factor reduce stretch-induced apoptosis of alveolar type II cells. *Respirology* **2010**, *15*, 343–348. [[CrossRef](#)] [[PubMed](#)]
65. Gerber, H.P.; Dixit, V.; Ferrara, N. Vascular endothelial growth factor induces expression of the antiapoptotic proteins Bcl-2 and A1 in vascular endothelial cells. *J. Biol. Chem.* **1998**, *273*, 13313–13316. [[CrossRef](#)] [[PubMed](#)]
66. Gerber, H.P.; McMurtrey, A.; Kowalski, J.; Yan, M.; Keyt, B.A.; Dixit, V.; Ferrara, N. Vascular endothelial growth factor regulates endothelial cell survival through the phosphatidylinositol 3'-kinase/Akt signal transduction pathway. Requirement for Flk-1/KDR activation. *J. Biol. Chem.* **1998**, *273*, 30336–30343. [[CrossRef](#)] [[PubMed](#)]
67. Alavi, A.; Hood, J.D.; Frausto, R.; Stupack, D.G.; Cheresch, D.A. Role of Raf in vascular protection from distinct apoptotic stimuli. *Science* **2003**, *301*, 94–96. [[CrossRef](#)] [[PubMed](#)]
68. Kasahara, Y.; Tuder, R.M.; Taraseviciene-Stewart, L.; Le Cras, T.D.; Abman, S.; Hirth, P.K.; Waltenberger, J.; Voelkel, N.F. Inhibition of VEGF receptors causes lung cell apoptosis and emphysema. *J. Clin. Investig.* **2000**, *106*, 1311–1319. [[CrossRef](#)] [[PubMed](#)]
69. Tang, K.; Rossiter, H.B.; Wagner, P.D.; Breen, E.C. Lung-targeted VEGF inactivation leads to an emphysema phenotype in mice. *J. Appl. Physiol.* **2004**, *97*, 1559–1566. [[CrossRef](#)] [[PubMed](#)]
70. Tuder, R.M.; Kasahara, Y.; Voelkel, N.F. Inhibition of vascular endothelial growth factor receptors causes emphysema in rats. *Chest* **2000**, *117*, 281S. [[CrossRef](#)]

71. Le Cras, T.D.; Spitzmiller, R.E.; Albertine, K.H.; Greenberg, J.M.; Whitsett, J.A.; Akeson, A.L. VEGF causes pulmonary hemorrhage, hemosiderosis, and air space enlargement in neonatal mice. *Am. J. Physiol. Lung Cell. Mol. Physiol.* **2004**, *287*, L134–L142. [[CrossRef](#)] [[PubMed](#)]
72. Bhandari, V.; Chho-Wing, R.; Chapoval, S.P.; Lee, C.G.; Tang, C.; Kim, Y.K.; Ma, B.; Baluk, P.; Lin, M.I.; McDonald, D.M.; et al. Essential role of nitric oxide in VEGF-induced, asthma-like angiogenic, inflammatory, mucus, and physiologic responses in the lung. *Proc. Natl. Acad. Sci. USA* **2006**, *103*, 11021–11026. [[CrossRef](#)] [[PubMed](#)]
73. Tsao, P.N.; Su, Y.N.; Li, H.; Huang, P.H.; Chien, C.T.; Lai, Y.L.; Lee, C.N.; Chen, C.A.; Cheng, W.F.; Wei, S.C.; et al. Overexpression of placenta growth factor contributes to the pathogenesis of pulmonary emphysema. *Am. J. Respir. Crit. Care Med.* **2004**, *169*, 505–511. [[CrossRef](#)] [[PubMed](#)]
74. Ranieri, V.M.; Rubenfeld, G.D.; Thompson, B.T.; Ferguson, N.D.; Caldwell, E.; Fan, E.; Camporota, L.; Slutsky, A.S. Acute respiratory distress syndrome: The Berlin Definition. ARDS Definition Task Force. *JAMA* **2012**, *307*, 2526–2533. [[PubMed](#)]
75. Ware, L.B.; Matthay, M.A. The acute respiratory distress syndrome. *N. Engl. J. Med.* **2000**, *342*, 1334–1349. [[CrossRef](#)] [[PubMed](#)]
76. Barratt, S.; Medford, A.R.; Millar, A.B. Vascular endothelial growth factor in acute lung injury and acute respiratory distress syndrome. *Respiration* **2014**, *87*, 329–342. [[CrossRef](#)] [[PubMed](#)]
77. Medford, A.R.; Godinho, S.I.; Keen, L.J.; Bidwell, J.L.; Millar, A.B. Relationship between vascular endothelial growth factor + 936 genotype and plasma/epithelial lining fluid vascular endothelial growth factor protein levels in patients with and at risk for ARDS. *Chest* **2009**, *136*, 457–464. [[CrossRef](#)] [[PubMed](#)]
78. Medford, A.R.; Keen, L.J.; Bidwell, J.L.; Millar, A.B. Vascular endothelial growth factor gene polymorphism and acute respiratory distress syndrome. *Thorax* **2005**, *60*, 244–248. [[CrossRef](#)] [[PubMed](#)]
79. Yang, S.; Cao, S.; Li, J.; Chang, J. Association between vascular endothelial growth factor + 936 genotype and acute respiratory distress syndrome in a Chinese population. *Genet. Test. Mol. Biomark.* **2011**, *15*, 737–740. [[CrossRef](#)] [[PubMed](#)]
80. Song, J.; Lu, H.; Zheng, X.; Huang, X. Effects of vascular endothelial growth factor in recovery phase of acute lung injury in mice. *Lung* **2015**, *193*, 1029–1036. [[CrossRef](#)] [[PubMed](#)]
81. Thickett, D.R.; Armstrong, L.; Millar, A.B. A role for vascular endothelial growth factor in acute and resolving lung injury. *Am. J. Respir. Crit. Care Med.* **2002**, *166*, 1332–1337. [[CrossRef](#)] [[PubMed](#)]
82. Maitre, B.; Boussat, S.; Jean, D.; Gouge, M.; Brochard, L.; Housset, B.; Adnot, S.; Delclaux, C. Vascular endothelial growth factor synthesis in the acute phase of experimental and clinical lung injury. *Eur. Respir. J.* **2001**, *18*, 100–106. [[CrossRef](#)] [[PubMed](#)]
83. Azamfirei, L.; Gurzu, S.; Solomon, R.; Copotoiu, R.; Copotoiu, S.; Jung, I.; Tilinca, M.; Branzaniuc, K.; Corneci, D.; Szederjesi, J.; et al. Vascular endothelial growth factor: A possible mediator of endothelial activation in acute respiratory distress syndrome. *Minerva Anesthesiol.* **2010**, *76*, 609–616. [[PubMed](#)]
84. Maniscalco, W.M.; Watkins, R.H.; Finkelstein, J.N.; Campbell, M.H. Vascular endothelial growth factor mRNA increases in alveolar epithelial cells during recovery from oxygen injury. *Am. J. Respir. Cell Mol. Biol.* **1995**, *13*, 377–386. [[CrossRef](#)] [[PubMed](#)]
85. He, C.H.; Waxman, A.B.; Lee, C.G.; Link, H.; Ra-bach, M.E.; Ma, B.; Chen, Q.; Zhu, Z.; Zhong, M.; Nakayama, K.; et al. Bcl-2-related protein A1 is an endogenous and cytokine-stimulated mediator of cytoprotection in hyperoxic acute lung injury. *J. Clin. Investig.* **2005**, *115*, 1039–1048. [[CrossRef](#)] [[PubMed](#)]
86. Kaner, R.J.; Ladetto, J.V.; Singh, R.; Fukuda, N.; Matthay, M.A.; Crystal, R.G. Lung overexpression of the vascular endothelial growth factor gene induces pulmonary edema. *Am. J. Respir. Cell Mol. Biol.* **2000**, *22*, 657–664. [[CrossRef](#)] [[PubMed](#)]
87. Watanabe, M.; Boyer, J.L.; Crystal, R.G. Genetic delivery of bevacizumab to suppress vascular endothelial growth factor-induced high-permeability pulmonary oedema. *Hum. Gene Ther.* **2009**, *20*, 598–610. [[CrossRef](#)] [[PubMed](#)]
88. Olson, A.L.; Swigris, J.J.; Lezotte, D.C.; Norris, J.M.; Wilson, C.G.; Brown, K.K. Mortality from pulmonary fibrosis increased in the United States from 1992 to 2003. *Am. J. Respir. Crit. Care Med.* **2007**, *176*, 277–284. [[CrossRef](#)] [[PubMed](#)]

89. Navaratnam, V.; Fleming, K.M.; West, J.; Smith, C.J.; Jenkins, R.G.; Fogarty, A.; Hubbard, R.B. The rising incidence of idiopathic pulmonary fibrosis in the U.K. *Thorax* **2011**, *66*, 462–467. [[CrossRef](#)] [[PubMed](#)]
90. Collard, H.R.; King, T.E., Jr.; Bartelson, B.B.; Vourlekis, J.S.; Schwarz, M.I.; Brown, K.K. Changes in clinical and physiologic variables predict survival in idiopathic pulmonary fibrosis. *Am. J. Respir. Crit. Care Med.* **2003**, *168*, 538–542. [[CrossRef](#)] [[PubMed](#)]
91. Raghu, G.; Weycker, D.; Edelsberg, J.; Bradford, W.Z.; Oster, G. Incidence and prevalence of idiopathic pulmonary fibrosis. *Am. J. Respir. Crit. Care Med.* **2006**, *174*, 810–816. [[CrossRef](#)] [[PubMed](#)]
92. Noble, P.W.; Albera, C.; Bradford, W.Z.; Costabel, U.; Glassberg, M.K.; Kardatzke, D.; King, T.K., Jr.; Lancaster, L.; Sahn, S.A.; Szwarzberg, J.; et al. Pirfenidone in patients with idiopathic pulmonary fibrosis (CAPACITY): Two randomised trials. *Lancet* **2016**, *377*, 1760–1769. [[CrossRef](#)]
93. Katzenstein, A.L.; Mukhopadhyay, S.; Myers, J.L. Diagnosis of usual interstitial pneumonia and distinction from other fibrosing interstitial lung diseases. *Hum. Pathol.* **2008**, *39*, 1275–1294. [[CrossRef](#)] [[PubMed](#)]
94. Cosgrove, G.P.; Brown, K.K.; Schiemann, W.P.; Serls, A.E.; Parr, J.E.; Geraci, M.W.; Schwarz, M.I.; Cool, C.D.; Worten, G.S. Pigment epithelium-derived factor in idiopathic pulmonary fibrosis: A role in aberrant angiogenesis. *Am. J. Respir. Crit. Care Med.* **2004**, *170*, 242–251. [[CrossRef](#)] [[PubMed](#)]
95. Ebina, M.; Shimizukawa, M.; Shibata, N.; Kimura, Y.; Suzuki, T.; Endo, M.; Sasano, H.; Kondo, T.; Nukiwa, T. Heterogeneous increase in CD34-positive alveolar capillaries in idiopathic pulmonary fibrosis. *Am. J. Respir. Crit. Care Med.* **2004**, *169*, 1203–1208. [[CrossRef](#)] [[PubMed](#)]
96. Turner-Warwick, M. Precapillary Systemic-Pulmonary Anastomoses. *Thorax* **1963**, *18*, 225–237. [[CrossRef](#)] [[PubMed](#)]
97. Myers, J.L.; Katzenstein, A.L. Epithelial necrosis and alveolar collapse in the pathogenesis of usual interstitial pneumonia. *Chest* **1988**, *94*, 1309–1311. [[CrossRef](#)] [[PubMed](#)]
98. Koyama, S.; Sato, E.; Tsukadaira, A.; Haniuda, M.; Numanami, H.; Kurai, M.; Nagai, S.; Izumi, T. Vascular endothelial growth factor mRNA and protein expression in airway epithelial cell lines in vitro. *Eur. Respir. J.* **2002**, *20*, 1449–1456. [[CrossRef](#)] [[PubMed](#)]
99. Ando, M.; Miyazaki, E.; Ito, T.; Hiroshige, S.; Nureki, S.I.; Ueno, T.; Takenaka, R.; Fukami, T.; Kumamoto, T. Significance of Serum Vascular Endothelial Growth Factor Level in Patients with Idiopathic Pulmonary Fibrosis. *Lung* **2010**, *188*, 247–252. [[CrossRef](#)] [[PubMed](#)]
100. Meyer, K.C.; Cardoni, A.; Xiang, Z.Z. Vascular endothelial growth factor in bronchoalveolar lavage from normal subjects and patients with diffuse parenchymal lung disease. *J. Lab. Clin. Med.* **2000**, *135*, 332–338. [[CrossRef](#)] [[PubMed](#)]
101. Murray, L.A.; Habel, D.M.; Hohmann, M.; Camelo, A.; Shang, H.; Zhou, Y.; Coelho, A.L.; Peng, X.; Gulati, M.; Crestani, B.; et al. Antifibrotic role of vascular endothelial growth factor in pulmonary fibrosis. *JCI Insight* **2017**, *2*. [[CrossRef](#)] [[PubMed](#)]
102. Simler, N.R.; Brenchley, P.E.; Horrocks, A.W.; Greaves, S.M.; Hasleton, P.S.; Egan, J.J. Angiogenic cytokines in patients with idiopathic interstitial pneumonia. *Thorax* **2004**, *59*, 581–585. [[CrossRef](#)] [[PubMed](#)]
103. Fagan, K.A.; McMurtry, I.F.; Rodman, D.M. Role of endothelin-1 in lung disease. *Respir. Res.* **2001**, *2*, 90–101. [[CrossRef](#)] [[PubMed](#)]
104. Renzoni, E.A. Neovascularisation in Idiopathic Pulmonary Fibrosis: too much or too little? *Am. J. Respir. Crit. Care Med.* **2004**, *169*, 1179–1180. [[CrossRef](#)] [[PubMed](#)]
105. Tzouveleki, A.; Anevlavis, S.; Bouros, D. Angiogenesis in interstitial lung diseases: A pathogenetic hallmark or a bystander? *Respir. Res.* **2006**, *7*, 82. [[CrossRef](#)] [[PubMed](#)]
106. Lee, S.; Chen, T.T.; Barber, C.L.; Jordan, M.C.; Murdock, J.; Desai, S.; Ferrara, N.; Nagy, A.; Roos, K.P.; Iruela-Arispe, M.L. Autocrine VEGF signaling is required for vascular homeostasis. *Cell* **2007**, *130*, 691–703. [[CrossRef](#)] [[PubMed](#)]
107. Stockmann, C.; Kerdiles, Y.; Nomaksteinsky, M.; Weidemann, A.; Takeda, N.; Doedens, A.; Torres-Collado, A.X.; Iruela-Arispe, L.; Nizet, V.; Johnson, R.S. Loss of myeloid cell-derived vascular endothelial growth factor accelerates fibrosis. *Proc. Natl. Acad. Sci. USA* **2010**, *107*, 4329–4334. [[CrossRef](#)] [[PubMed](#)]
108. Hamada, N.; Kuwano, K.; Yamada, M.; Hagimoto, N.; Hiasa, K.; Egashira, K.; Nakashima, N.; Maeyama, T.; Yoshimi, M.; Nakanishi, Y. Anti-vascular endothelial growth factor gene therapy attenuates lung injury and fibrosis in mice. *J. Immunol.* **2005**, *175*, 1224–1231. [[CrossRef](#)] [[PubMed](#)]

109. Chaudhary, N.I.; Roth, G.J.; Hilberg, F.; Muller-Quernheim, J.; Prasse, A.; Zissel, G.; Schnapp, A.; Park, J.E. Inhibition of PDGF, VEGF and FGF signalling attenuates fibrosis. *Eur. Respir. J.* **2007**, *29*, 976–985. [[CrossRef](#)] [[PubMed](#)]
110. Farkas, L.; Farkas, D.; Ask, K.; Moller, A.; Gaudie, J.; Margetts, P.; Inman, M.; Kolb, M. VEGF ameliorates pulmonary hypertension through inhibition of endothelial apoptosis in experimental lung fibrosis in rats. *J. Clin. Investig.* **2009**, *119*, 1298–1311. [[CrossRef](#)] [[PubMed](#)]
111. Selman, M.; Pardo, A.; King, T.E., Jr. Hypersensitivity pneumonitis: Insights in diagnosis and pathobiology. *Am. J. Respir. Crit. Care Med.* **2012**, *186*, 314–324. [[CrossRef](#)] [[PubMed](#)]
112. Spagnolo, P.; Rossi, G.; Cavazza, A.; Bonifazi, M.; Paladini, I.; Bonella, F.; Sverzellati, N.; Costabel, U. Hypersensitivity Pneumonitis: A Comprehensive Review. *J. Investig. Allergol. Clin. Immunol.* **2015**, *25*, 237–250. [[PubMed](#)]
113. Selman, M.; Pardo, A.; Barrera, L.; Estrada, A.; Watson, S.R.; Wilson, K.; Aziz, N.; Kaminski, N.; Zlotnik, A. Gene expression profiles distinguish idiopathic pulmonary fibrosis from hypersensitivity pneumonitis. *Am. J. Respir. Crit. Care Med.* **2006**, *173*, 188–198. [[CrossRef](#)] [[PubMed](#)]
114. Gifford, A.H.; Matsuoka, M.; Ghoda, L.Y.; Homer, R.J.; Enelow, R.I. Chronic inflammation and lung fibrosis: Pleotropic syndromes but limited distinct phenotypes. *Mucosal Immunol.* **2012**, *5*, 480–484. [[CrossRef](#)] [[PubMed](#)]
115. Willems, S.; Verleden, S.E.; Vanaudenaerde, B.M.; Wynants, M.; Doms, C.; Yserbyt, J.; Somers, J.; Verbeke, E.K.; Verleden, G.M.; Wuyts, W.A. Multiplex protein profiling of bronchoalveolar lavage in idiopathic pulmonary fibrosis and hypersensitivity pneumonitis. *Ann. Thorac. Med.* **2013**, *8*, 38–45. [[PubMed](#)]
116. Jinta, T.; Miyazaki, Y.; Kishi, M.; Akashi, T.; Takemura, T.; Inase, N.; Yoshizawa, Y. The pathogenesis of chronic hypersensitivity pneumonitis in common with idiopathic pulmonary fibrosis: Expression of apoptotic markers. *Am. J. Clin. Pathol.* **2010**, *134*, 613–620. [[CrossRef](#)] [[PubMed](#)]
117. Navarro, C.; Ruiz, V.; Gaxiola, M.; Carrillo, G.; Selman, M. Angiogenesis in hypersensitivity pneumonitis. *Arch. Physiol. Biochem.* **2003**, *111*, 365–368. [[CrossRef](#)] [[PubMed](#)]
118. Yamashita, M.; Mouri, T.; Niisato, M.; Nitani, H.; Kobayashi, H.; Ogasawara, M.; Endo, R.; Konishi, K.; Sugai, T.; Sawai, T.; et al. Lymphangiogenic factors are associated with the severity of hypersensitivity pneumonitis. *BMJ Open Respir. Res.* **2015**, *2*, e000085. [[CrossRef](#)] [[PubMed](#)]
119. Alitalo, K. The lymphatic vasculature in disease. *Nat. Med.* **2011**, *17*, 1371–1380. [[CrossRef](#)] [[PubMed](#)]
120. Gutsche, M.; Rosen, G.D.; Swigris, J.J. Connective Tissue Disease-associated Interstitial Lung Disease: A review. *Curr. Respir. Care Rep.* **2012**, *1*, 224–232. [[CrossRef](#)] [[PubMed](#)]
121. Herrick, A.L. Pathogenesis of Raynaud's phenomenon. *Rheumatology* **2005**, *44*, 587–596. [[CrossRef](#)] [[PubMed](#)]
122. Van Hal, T.W.; van Bon, L.; Radstake, T.R. A system out of breath: How hypoxia possibly contributes to the pathogenesis of systemic sclerosis. *Int. J. Rheumatol.* **2011**, 824972. [[CrossRef](#)] [[PubMed](#)]
123. Steen, V.D.; Medsger, T.A. Changes in causes of death in systemic sclerosis, 1972–2002. *Ann. Rheum. Dis.* **2007**, *66*, 940–944. [[CrossRef](#)] [[PubMed](#)]
124. Freemont, A.J.; Hoyland, J.; Fielding, P.; Hodson, N.; Jayson, M.I. Studies of the microvascular endothelium in uninvolved skin of patients with systemic sclerosis: Direct evidence for a generalized microangiopathy. *Br. J. Dermatol.* **1992**, *126*, 561–568. [[CrossRef](#)] [[PubMed](#)]
125. Prescott, R.J.; Freemont, A.J.; Jones, C.J.; Hoyland, J.; Fielding, P. Sequential dermal microvascular and perivascular changes in the development of scleroderma. *J. Pathol.* **1992**, *166*, 255–263. [[CrossRef](#)] [[PubMed](#)]
126. Roumm, A.D.; Whiteside, T.L.; Medsger, T.A., Jr.; Rodnan, G.P. Lymphocytes in the skin of patients with progressive systemic sclerosis. Quantification, subtyping, and clinical correlations. *Arthritis Rheum.* **1984**, *27*, 645–653. [[CrossRef](#)] [[PubMed](#)]
127. Koenig, M.; Joyal, F.; Fritzler, M.J.; Roussin, A.; Abrahamowicz, M.; Boire, G.; Goulet, J.R.; Rich, E.; Grodzicky, T.; Raymond, Y.; et al. Autoantibodies and microvascular damage are independent predictive factors for the progression of Raynaud's phenomenon to systemic sclerosis: A twenty-year prospective study of 586 patients, with validation of proposed criteria for early systemic sclerosis. *Arthritis Rheum.* **2008**, *58*, 3902–3912. [[CrossRef](#)] [[PubMed](#)]
128. Sulli, A.; Ruaro, B.; Alessandri, E.; Pizzorni, C.; Cimmino, M.A.; Zampogna, G.; Gallo, M.; Cutolo, M. Correlations between nailfold microangiopathy severity, finger dermal thickness and fingertip blood perfusion in systemic sclerosis patients. *Ann. Rheum. Dis.* **2014**, *73*, 247–251. [[CrossRef](#)] [[PubMed](#)]

129. Distler, O.; Distler, J.H.; Scheid, A.; Acker, T.; Hirth, A.; Rethage, J.; Michel, B.A.; Gay, R.E.; Müller-Ladner, U.; Matucci-Cerinic, M.; et al. Uncontrolled expression of vascular endothelial growth factor and its receptors leads to insufficient skin angiogenesis in patients with systemic sclerosis. *Circ. Res.* **2004**, *95*, 109–116. [[CrossRef](#)] [[PubMed](#)]
130. Marti, H.H.; Risau, W. Systemic hypoxia changes the organ-specific distribution of vascular endothelial growth factor and its receptors. *Proc. Natl. Acad. Sci. USA* **1998**, *95*, 15809–15814. [[CrossRef](#)] [[PubMed](#)]
131. Distler, O.; Del Rosso, A.; Giacomelli, R.; Cipriani, P.; Conforti, M.L.; Guiducci, S.; Gay, R.E.; Michel, B.A.; Brühlmann, P.; Müller-Ladner, U.; et al. Angiogenic and angiostatic factors in systemic sclerosis: Increased levels of vascular endothelial growth factor are a feature of the earliest disease stages and are associated with the absence of fingertip ulcers. *Arthritis Res.* **2002**, *4*, R11. [[CrossRef](#)] [[PubMed](#)]
132. Avouac, J.; Wipff, J.; Goldman, O.; Ruiz, B.; Couraud, P.O.; Chiochia, G.; Kahan, A.; Boileau, C.; Uzan, G.; Allanore, Y. Angiogenesis in Systemic Sclerosis Impaired Expression of Vascular Endothelial Growth Factor Receptor 1 in Endothelial Progenitor-Derived Cells Under Hypoxic Conditions. *Arthritis Rheum.* **2008**, *58*, 3550–3561. [[CrossRef](#)] [[PubMed](#)]
133. Manetti, M.; Guiducci, S.; Romano, E.; Bellando-Randone, S.; Lepri, G.; Bruni, C.; Conforti, M.L.; Ibba-Manneschi, L.; Matucci-Cerinic, M. Increased plasma levels of the VEGF165b splice variant are associated with the severity of nailfold capillary loss in systemic sclerosis. *Ann. Rheum. Dis.* **2013**, *72*, 1425–1427. [[CrossRef](#)] [[PubMed](#)]
134. De Santis, M.; Bosello, S.L.; Capoluongo, E.; Inzitari, R.; Peluso, G.; Lulli, P.; Zizzo, G.; Bocci, M.; Tolusso, B.; Zuppi, C.; et al. A vascular endothelial growth factor deficiency characterises scleroderma lung disease. *Ann. Rheum. Dis.* **2012**, *71*, 1461–1465. [[CrossRef](#)] [[PubMed](#)]
135. De Santis, M.; Ceribelli, A.; Cavaciocchi, F.; Crotti, C.; Massarotti, M.; Belloli, L.; Marasini, B.; Isailovic, N.; Generali, E.; Selmi, C. Nailfold videocapillaroscopy and serum VEGF levels in scleroderma are associated with internal organ involvement. *Auto-Immun. Highlights* **2016**, *7*, 5. [[CrossRef](#)] [[PubMed](#)]
136. Huang, J.; Maier, C.; Zhang, Y.; Soare, A.; Dees, C.; Beyer, C.; Harre, U.; Chen, C.W.; Distler, O.; Schett, G.; et al. Nintedanib inhibits macrophage activation and ameliorates vascular and fibrotic manifestations in the Fra2 mouse model of systemic sclerosis. *Ann. Rheum. Dis.* **2017**, *76*, 1941–1948. [[CrossRef](#)] [[PubMed](#)]
137. Grundtman, C.; Tham, E.; Ulfgren, A.K.; Lundberg, I.E. Vascular endothelial growth factor is highly expressed in muscle tissue of patients with polymyositis and patients with dermatomyositis. *Arthritis Rheum.* **2008**, *58*, 3224–3238. [[CrossRef](#)] [[PubMed](#)]
138. Volpi, N.; Pecorelli, A.; Lorenzoni, P.; Di Lazzaro, F.; Belmonte, G.; Agliano, M.; Cantarini, L.; Giannini, F.; Grasso, G.; Valacchi, G. Antiangiogenic VEGF isoform in inflammatory myopathies. *Mediat. Inflamm.* **2013**, *2013*, 219313. [[CrossRef](#)] [[PubMed](#)]
139. Kikuchi, K.; Kubo, M.; Kadono, T.; Yazawa, N.; Ihn, H.; Tamaki, K. Serum concentrations of vascular endothelial growth factor in collagen diseases. *Br. J. Dermatol.* **1998**, *139*, 1049–1051. [[CrossRef](#)] [[PubMed](#)]
140. Tanaseanu, C.; Tudor, S.; Tamsulea, I.; Marta, D.; Manea, G.; Moldoveanu, E. Vascular endothelial growth factor, lipoprotein-associated phospholipase A2, sP-selectin and antiphospholipid antibodies, biological markers with prognostic value in pulmonary hypertension associated with chronic obstructive pulmonary disease and systemic lupus erythematosus. *Eur. J. Med. Res.* **2007**, *12*, 145–151. [[PubMed](#)]
141. Distler, J.H.; Strapatsas, T.; Huscher, D.; Dees, C.; Akhmetshina, A.; Kiener, H.P.; Tarnier, I.H.; Maurer, B.; Walder, M.; Michel, B.; et al. Dysbalance of angiogenic and angiostatic mediators in patients with mixed connective tissue disease. *Ann. Rheum. Dis.* **2011**, *70*, 1197–1202. [[CrossRef](#)] [[PubMed](#)]
142. Iwakawa, J.; Matsuyama, W.; Kubota, S.; Mitsuyama, H.; Suetsugu, T.; Watanabe, M.; Higashimoto, I.; Osame, M.; Arimura, K. Increased serum vascular endothelial growth factor levels in microscopic polyangiitis with pulmonary involvement. *Respir. Med.* **2006**, *100*, 1724–1733. [[CrossRef](#)] [[PubMed](#)]
143. Hashimoto, N.; Iwasaki, T.; Kitano, M.; Ogata, A.; Hamano, T. Levels of vascular endothelial growth factor and hepatocyte growth factor in sera of patients with rheumatic diseases. *Mod. Rheumatol.* **2003**, *13*, 129–134. [[CrossRef](#)] [[PubMed](#)]
144. Kuryliszyn-Moskal, A.; Klimiuk, P.A.; Sierakowski, S.; Ciolkiewicz, M. A study on vascular endothelial growth factor and endothelin-1 in patients with extra-articular involvement of rheumatoid arthritis. *Clin. Rheumatol.* **2006**, *25*, 314–319. [[CrossRef](#)] [[PubMed](#)]

145. Roth, D.A.; McKirnan, M.D.; Canestrelli, I.; Gao, M.H.; Dalton, N.; Lai, N.C.; Roth, D.M.; Hammond, H.K. Intracoronary delivery of an adenovirus encoding fibroblast growth factor-4 in myocardial ischemia: Effect of serum antibodies and previous exposure to adenovirus. *Hum. Gene Ther.* **2006**, *17*, 230–238. [[CrossRef](#)] [[PubMed](#)]
146. Sarkar, N.; Rück, A.; Källner, G.; Y-Hassan, S.; Blomberg, P.; Islam, K.B.; van der Linden, J.; Lindblom, D.; Nygren, A.T.; Lind, B.; et al. Effects of intramyocardial injection of phVEGF-A165 as sole therapy in patients with refractory coronary artery disease—12-Month follow-up: Angiogenic gene therapy. *J. Intern. Med.* **2001**, *250*, 373–381. [[CrossRef](#)] [[PubMed](#)]



© 2018 by the authors. Licensee MDPI, Basel, Switzerland. This article is an open access article distributed under the terms and conditions of the Creative Commons Attribution (CC BY) license (<http://creativecommons.org/licenses/by/4.0/>).