

ISWS 6-73

loan copy

3

*cular 15*

STATE OF ILLINOIS

WILLIAM G. STRATTON, *Governor*

DEPARTMENT OF REGISTRATION AND EDUCATION

VERA M. BINKS, *Director*



*Effect of  
Metal Grating Deck  
On Drop-Inlet Spillway Performance*

H. W. HUMPHREYS AND G. SIGURDSSON

STATE WATER SURVEY DIVISION

WILLIAM C. ACKERMANN, *Chief*

URBANA

1959



# *Effect of Metal Grating Deck On Drop-Inlet Spillway Performance*

H. W. HUMPHREYS AND G. SIGURDSSON

Model tests were performed on a drop-inlet spillway to determine whether or not a metal grating deck placed above the inlet can control vortices. The results of these tests show that gratings do not prevent or control strong vortices.

## FOREWORD

The Engineering and Watershed Planning Unit of the U. S. Soil Conservation Service, Fort Worth, Texas, suggested replacing the wooden deck, anti-vortex device with a metal grating deck. Testing the effectiveness of grating as an anti-vortex device was desirable because vortex formation can be a serious problem for drop-inlet spillways.

The Illinois State Water Survey of Urbana, Illinois, in cooperation with the U. S. Agricultural Research Service, the U. S. Soil Conservation Service, and the University of Illinois Agricultural Experiment Station, is conducting a generalized research program on drop-inlet spillways. One of the objectives of the program is to control the vortex formation at the spillway inlet.

The experimental apparatus for this program can and does develop very strong vortices; and therefore, the State Water Survey agreed to test model gratings for a drop-inlet spillway.

## INTRODUCTION

Six series of tests were conducted on a model of a drop-inlet spillway having a rectangular riser and a circular barrel. Several combinations of expanded metal, hardware cloth, and screen wire were used to give various ratios of open area to total area of grating. The grating was supported by four corner posts on the inlet crest. These posts were in place for all tests.

It should be noted that the gratings used in the tests were not models of any commercial gratings. Therefore, the comparison between model and prototype gratings was made on the basis of the ratio of the open area to the total area.

The screen, hardware cloth, and expanded metal were combined to give a range of open area to total area, varying from 54 percent to 25 percent. One suggested prototype grating had an open area of approximately 55 percent while another had approximately 78 percent. The proposed prototype gratings had a thickness of 1 inch to 2 inches.

The various flow conditions for drop-inlet spillways have been fully described by Blaisdell.<sup>(1)</sup>

<sup>1</sup> Blaisdell, Fred W., "Hydraulics of Closed Conduit Spillways. Parts II through VII, Results of Tests on Several Forms of the Spillway," St. Anthony Falls Hydraulic Laboratory Technical Paper No. 18, Series B, March 1958.

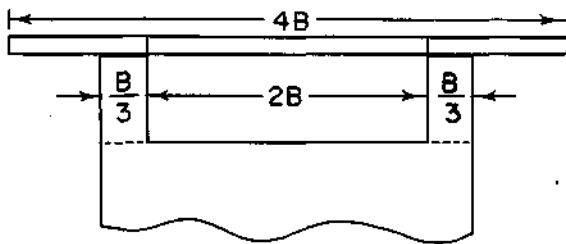

Fig. 1-A

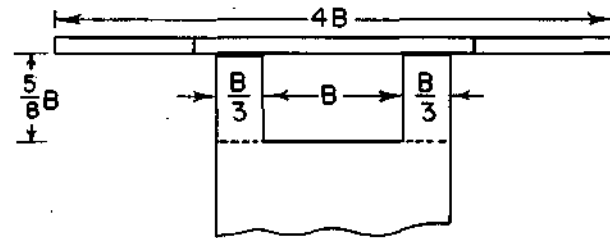

Fig. 1-B

Fig. 1-C PLAN OF INLET WITH  
MODEL GRATING REMOVED

Fig. 1-D HALF PLAN OF MODEL GRATING

FIG. 1 MODEL INLET DIMENSIONS

## DESCRIPTION OF SPILLWAY

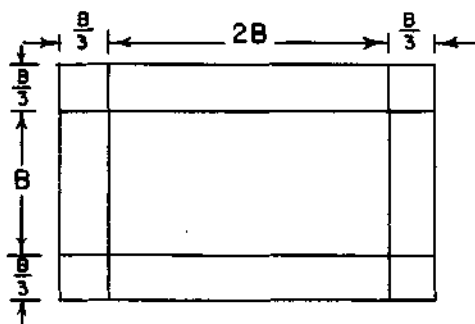
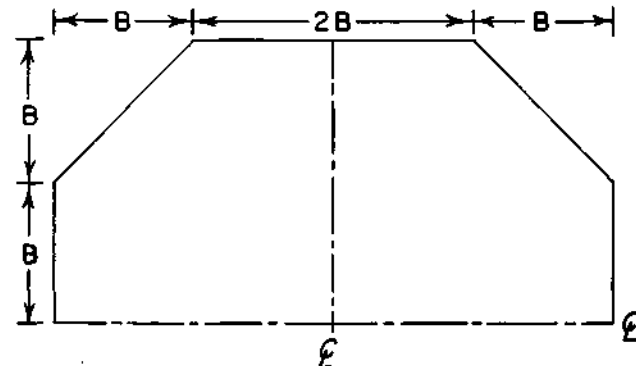
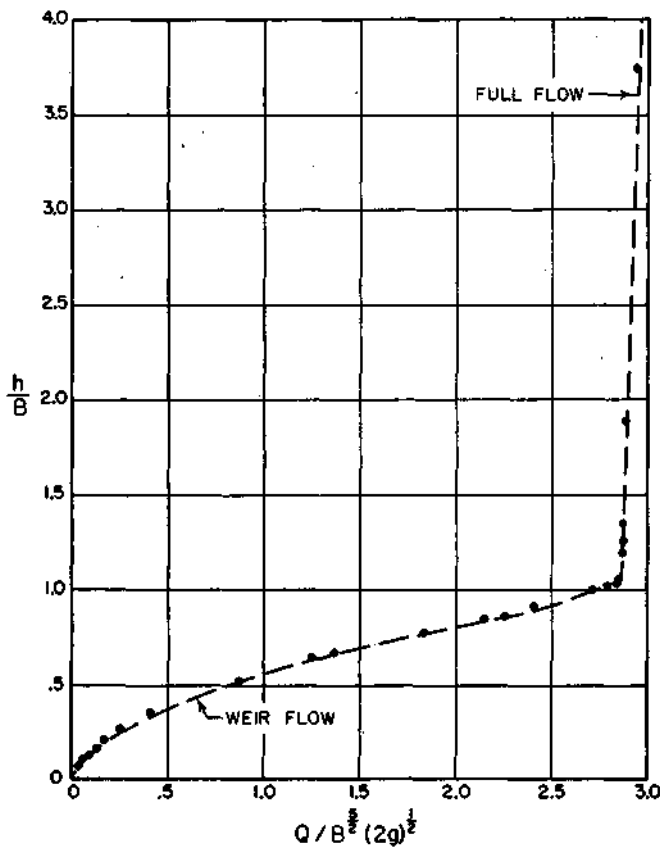

FIG. 2 HEAD-DISCHARGE CURVE, SERIES 20,  
WITH CROSS-VANES

The pertinent inlet dimensions are shown on figure 1. The model riser was five barrel diameters (5D) high to insure priming. It was rectangular in cross section, twice as long as it was wide (2B by B). The shorter side of the riser was equal to the barrel diameter (B=D). The thickness of the square inlet crest was one-third of the riser width (B/3). The barrel was 100D long and was connected to the shorter side of the riser with a rounded transition. The 30.2 percent barrel slope is considerably steeper than the hydraulic grade line slope. The barrel discharged freely into the atmosphere.

The model was constructed from Lucite and Plexiglass for observing the spillway performance. The approach channel has glass side walls for observing and photographing flow conditions above the inlet and in the riser. The rate of flow into the head pool was measured by bend meters calibrated in place. The head pool level was continuously recorded. The instantaneous spillway outflow was determined by knowing the inflow and taking into consideration the rate of change in storage in the head pool.

## TEST PROGRAM

The tests were planned to indicate the effect that different percentages of open areas of grating have on vortex formation.

The six series of tests performed are shown in table 1.

The head loss coefficients for the model gratings were not determined because the performance of gratings as an anti-vortex device was of primary interest.

TABLE 1

## MODEL TESTS PERFORMED

Series No.	Inlet	Percent Open Area	Remarks
20	No grating. Vortex fully controlled with cross vanes	...	Unique rating curve obtained
21	No grating. No anti-vortex device	...	Vortex formation, unpredictable rating curve
18	Expanded metal, 1/4" and 1/8" hardware cloth, and 1/16" screen wire	25	No unique rating curve
19	Expanded metal, 1/4" and 1/8" hardware cloth	38	Vortex formation, unpredictable rating curve
22	Expanded metal and 1/4" hardware cloth	54	Vortex formation, unpredictable rating curve
23	1/4" hardware cloth and 1/16" screen wire	53	Vortex formation, unpredictable rating curve

## RESULTS

The test results are given in figures 2-7 for the individual series of tests, and figure 8 gives a composite plot of the individual curves. The dashed curve shown on figures 2 through 8 is the average curve obtained for all weir and full flow discharges.

Series 20 was the only test (fig. 2) that resulted in a unique head-discharge curve. The vortex was fully controlled by placing cross vanes on the inlet crest-

Series 21 was performed without any anti-vortex device to determine the effect of vortices on the model spillway. When a vortex influences the flow, the head and the discharge vary in a random and erratic fashion. Figure 3 shows the unpredictable nature of the head-discharge curve due to the vortex.

The curve to the left of the vortex envelope on figure 3 represents an unusual flow condition. Orifice flow occurred at the inlet with a vortex through the jet. The occurrence of this flow condition was unpredictable. A cycle of this flow condition has begun with the nappe clinging to the sides of the riser and a vortex drawing air into the spillway. The reservoir level was unsteady. Without any warning, the nappe sprang free from the inlet crest and the reservoir level changed abruptly, rising very rapidly indicating a large decrease in discharge. The air supplied by the vortex to the spillway was entrained down in the riser. Most of this entrained air was carried out through the barrel, but some found its way into the pocket between the nappe and the riser wall, thus aerating the nappe. The nappe remained free for an unpredictable period of time and then it changed abruptly to a clinging nappe. The reservoir level immediately began to fall rapidly indicating an increase in discharge. The vortex was very strong throughout this cycle of changing flow conditions.

Series 18, 19, 22, and 23 were performed to determine what effect model gratings of various percentages of open area would have on vortices. Figures 4, 5, 6, and 7 show that a unique head-discharge curve was not obtained.

The reservoir level did not fluctuate erratically for Series 18, having 25 percent open area; but the rating curves for rising and falling heads were not the same. Some of the openings of the small screens were sealed by surface tension during the falling head and obstructed the air flow being drawn into the spillway. The openings were not closed on the rising head until the screens became submerged. Series 23 also shows this effect of surface tension.

Figures 9 and 10 show the effect of different combinations of screens on the vortex. In Series 22, having 54 percent open area (fig. 9), the vortex core was reduced in size below the screen, however the air intake through the vortex was evident. Series 18, having 25 percent open area (fig. 10), indicated that the grating open area can be reduced to where the vortex remains above the screen and the spillway is full of water.

## CONCLUSIONS

- (1) The model gratings did not eliminate the vortex.
- (2) The model gratings reduced the vortex effect, but substantial reduction occurs only when the percentage of open area is much smaller than is found on commercial grating.
- (3) The vortex core below the screens was smaller than the core above the screens.
- (4) The screens did not affect the full flow capacity of the model spillway after the barrel controlled the rate of flow at high heads. The vortex effect on the head-discharge curve is negligible at high heads.
- (5) The reservoir level had erratic fluctuations for Series 21, 19, 22, and 23 because the vortex was not controlled.
- (6) Orifice flow with a vortex through the jet is possible for this sharp crested riser.

## RECOMMENDATIONS

Grating used as anti-vortex device at the inlet of drop-inlet spillways is not recommended.

List of symbols used in plotting the head-discharge curves.

- Q — Discharge, in cubic feet per second
- h — Head on drop inlet crest, in feet
- B — Width of drop inlet, feet
- D — Barrel Diameter, in feet
- g — Acceleration due to gravity, 32.16 feet per second per second

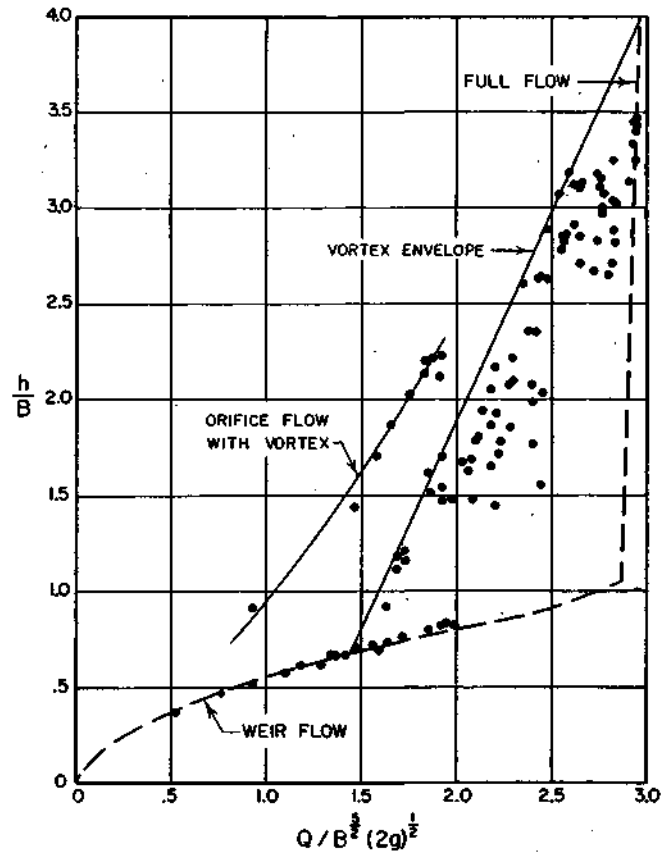

FIG. 3 HEAD-DISCHARGE CURVE, SERIES 21, NO SCREENS

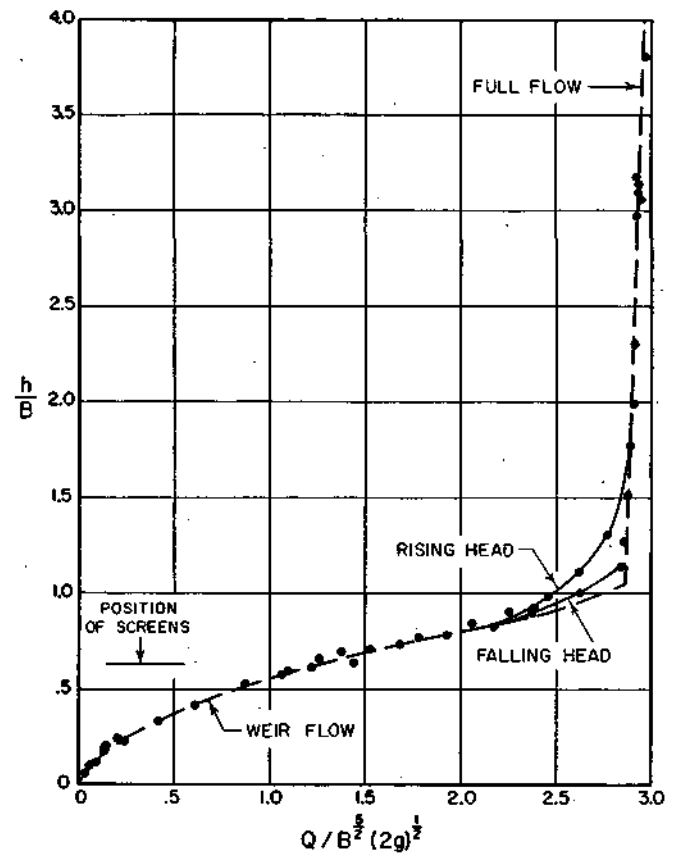

FIG. 4 HEAD-DISCHARGE CURVE, SERIES 18, WITH SCREENS, 25 PERCENT OPEN AREA

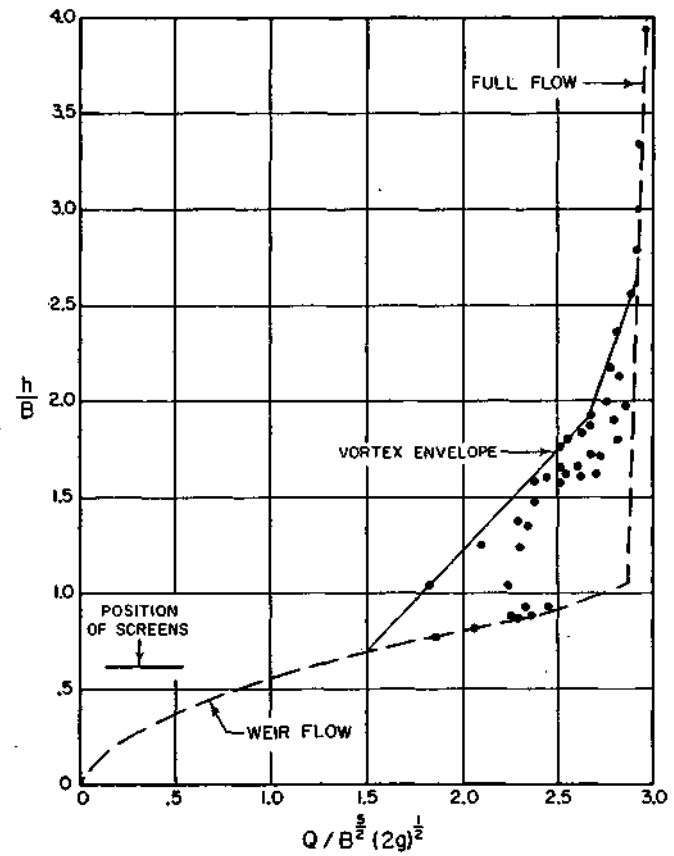
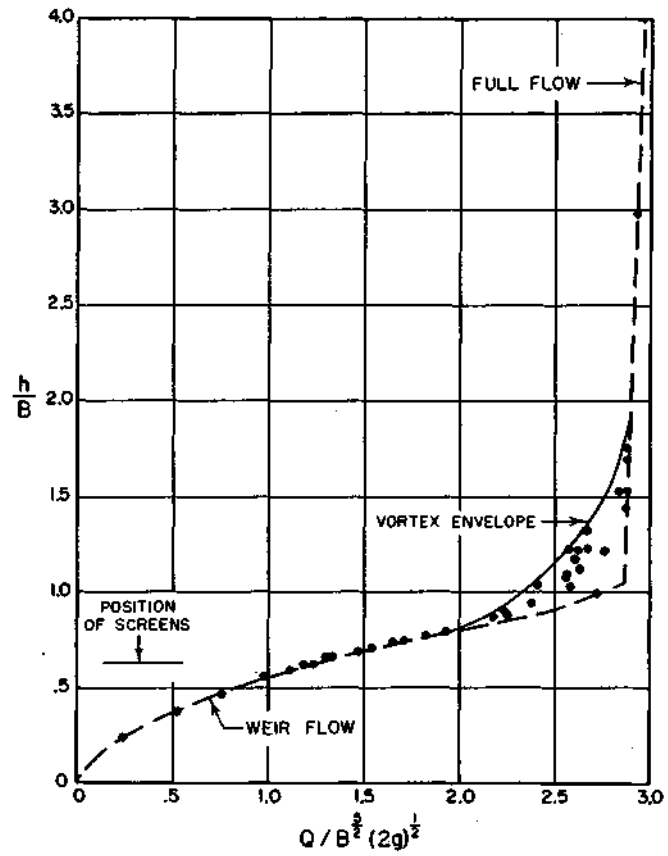

FIG. 5 HEAD-DISCHARGE CURVE, SERIES 19, WITH SCREENS, 38 PERCENT OPEN AREA

FIG. 6 HEAD-DISCHARGE CURVE, SERIES 22, WITH SCREENS, 54 PERCENT OPEN AREA



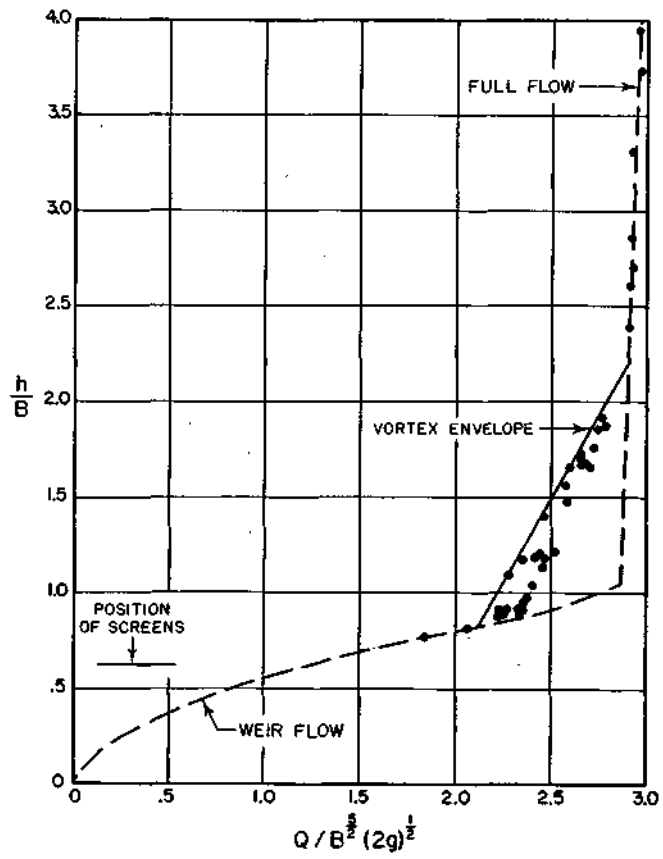

FIG. 7 HEAD-DISCHARGE CURVE, SERIES 23, WITH SCREENS, 53 PERCENT OPEN AREA

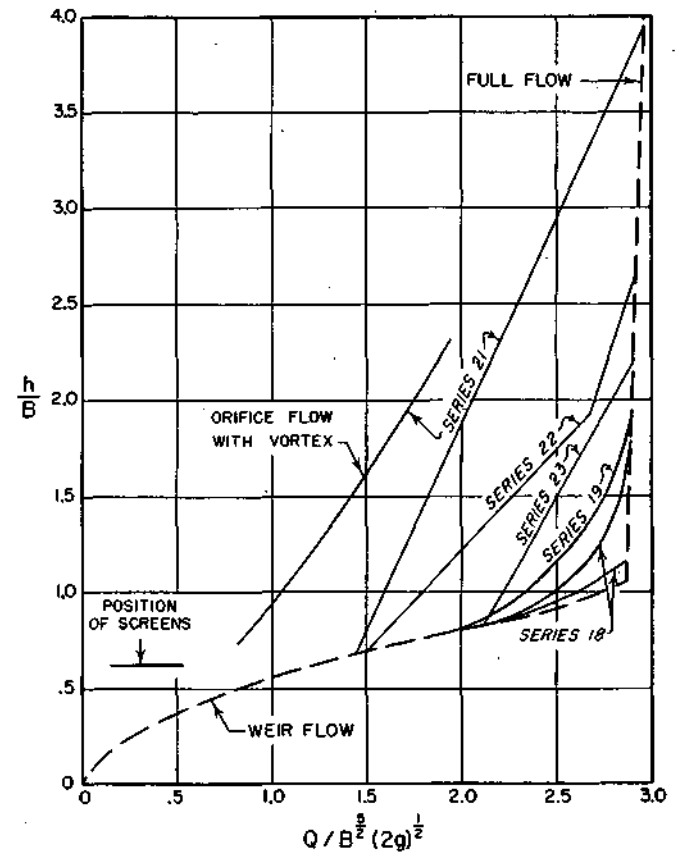

FIG. 8 COMPOSITE PLOT OF HEAD-DISCHARGE CURVES SHOWING VORTEX ENVELOPES

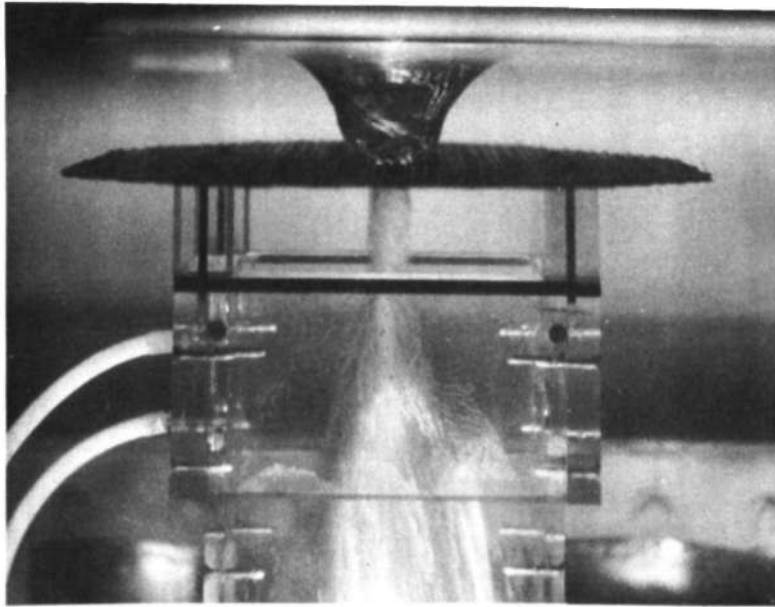

FIG. 9 VORTEX FOR SERIES 22, 54 PERCENT OPEN AREA,  
 $h/B = 1.49$ ,  $Q/B^{5/2} (2g)^{1/2} = 2.37$

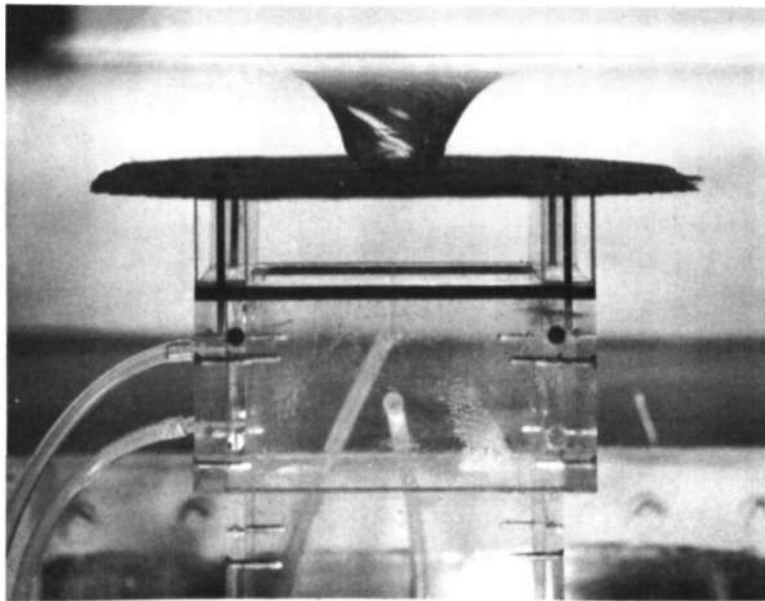

FIG. 10 VORTEX FOR SERIES 18, 25 PERCENT OPEN AREA,  
 $h/B = 1.53$ ,  $Q/B^{5/2} (2g)^{1/2} = 2.88$