

Contract Report 596

Hydraulic and Sediment Analysis for Panther Slough, Sanganois Conservation Area

by
Ta Wei Soong and Renjie Xia
Office of Hydraulics & River Mechanics

Prepared for the
Illinois Department of Natural Resources

March 1996

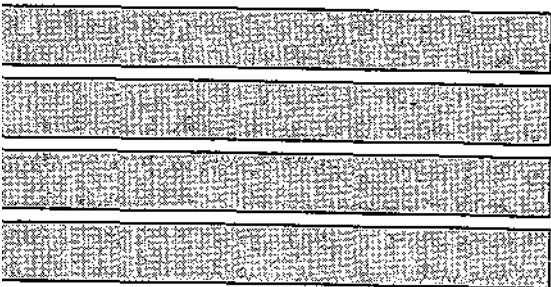

Illinois State Water Survey
Hydrology Division
Champaign, Illinois

A Division of the Illinois Department of Natural Resources

**Hydraulic and Sediment Analysis
for Panther Slough, Sanganois Conservation Area**

Prepared by:

Ta Wei Soong and Renjie Xia
Office of Hydraulics & River Mechanics
Illinois State Water Survey
2204 Griffith Drive, Champaign, IL 61820

Final report to the Illinois Department of Natural Resources
in partial fulfillment of project requirements

March 31, 1996

This report was printed on recycled and recyclable papers.

TABLE OF CONTENTS

INTRODUCTION.....	1
Study Objectives.....	4
Study Approach.....	5
Acknowledgments.....	5
BACKGROUND INFORMATION.....	7
Description of the Study Area.....	7
Available Data.....	9
Illinois Natural History Survey Data.....	9
Illinois State Water Survey Data.....	9
River Stage and Discharge Data.....	11
Precipitation Data.....	11
HYDROLOGY, HYDRAULICS, AND SEDIMENT IN THE STUDY AREA.....	12
Hydrology.....	12
Lake Elevation.....	12
Drainage Area.....	13
River Stages.....	14
Precipitation.....	14
Determination of Discharges from Chain Lake to Panther Slough.....	15
Calculating Discharge from Existing Velocity Data.....	15
Estimating Discharge from Flow Diversions.....	17
Determination of Maximum Discharge for Culvert Design.....	22
Hydraulics.....	25
Sediment Characteristics.....	27
Design Discharge for the Control Structure.....	29
Consideration of Sedimentation Patterns.....	30
SEDIMENT TRANSPORT IN PANTHER SLOUGH.....	32
Critical Tractive Shear Stress.....	32
Empirical Formulas.....	35
Theoretical and Semitheoretical Formulas.....	36
Average Shear Stress.....	37
CULVERT DESIGN.....	38
Culvert Hydraulics.....	38
Determination of Culvert Size.....	40
MODELING PANTHER SLOUGH.....	42
HEC-6 Model.....	42
Input Data Requirements.....	43
Application of the HEC-6 Model to Panther Slough.....	44
Geometric Data.....	44
Manning's Roughness Coefficient.....	44
Sediment Data.....	44

Hydrologic Data	47
Downstream Boundary Conditions	47
Model Calibration	47
Model Results and Discussion	48
Impacts to Discharge and Stage	49
Sedimentation Patterns in Panther Slough	52
SUMMARY	58
REFERENCES	61
APPENDIX	63

LIST OF TABLES

Table 1. Dimensions of Water Bodies in the Study Area	7
Table 2. Calculated Monthly Stages (in ft) at RM 98.8 and RM 113.3	14
Table 3. Monthly Precipitation (in inches) at Kilbourne Station	14
Table 4. Monthly Discharges (in cfs) from Chain Lake to Panther Slough	16
Table 5. Monthly Water Surface Elevations at RM 98.8	17
Table 6. Monthly Discharge (in cfs) from Chain Lake to Panther Slough under Nonflooding Conditions	17
Table 7. Calculated Discharge from Chain Lake under Nonflooding Conditions	22
Table 8. Data Measured during Field Surveys	26
Table 9. Suspended Sediment Concentration (in mg/l) in Panther Slough	28
Table 10. Composition of Bed Materials	28
Table 11. Monthly Mean Sediment Concentration (in mg/l) at Valley City, 1993	29
Table 12. Calculated Critical Tractive Stress in Panther Slough	33
Table 13. Calculated Critical Tractive Stress in Panther Slough for Selected Equations	36
Table 14. Hydraulic Head under Management Plan (in ft)	40
Table 15. Ranges of Pool Elevations (in ft) in La Grange L & D	47
Table 16. Comparisons of Model Results with Measured Data	48
Table 17. Inflow Discharge (in cfs) without Structure - Flow Data Set 1	49
Table 18. Inflow Discharge (in cfs) with Structure - Flow Data Set 2	51
Table 19. Inflow Discharge (in cfs) during Nonflooding Conditions without Structure - Flow Data Set 3	52
Table 20. Inflow Discharge (in cfs) during Nonflooding Conditions with Structure - Flow Data Set 4	52
Table 21. Comparison of Bed Changes (in ft) with and without Structure Using Flow Data Sets 1 and 2	53
Table 22. Comparison of Bed Changes (in ft) with and without Structure Using Flow Data Sets 3 and 4	54

LIST OF FIGURES

Figure 1. Sanganois Conservation Area.....	2
Figure 2. Old control structure.....	3
Figure 3. Chain Lake, Panther Slough, and adjacent lakes.....	8
Figure 4. Surveyed cross sections on Panther Slough.....	10
Figure 5. Monthly average discharges as calculated by the diversion method.....	21
Figure 6. Average monthly discharge for September (a), October (b), November (c), and December (d) as estimated by the diversion method.....	23
Figure 7. Relationship between water surface elevation at RM 98.8 and discharge measured by INHS (a) and discharge calculated by equation 2 (b).....	24
Figure 8. Variation of $\frac{\tau_{oc}}{(\gamma_s - \gamma_w)d}$ with R_c^* obtained by Shields (1936).....	34
Figure 9. Variation of $\frac{\tau_{oc}}{(\gamma_s - \gamma_w)d}$ with R_c^* obtained by Yalin and Karahan (1979).....	34
Figure 10. Possible conditions of flow through culverts (after Mavis, 1943)___	39
Figure 11. Effect of downstream stages on sedimentation patterns in April (a) and August (b).....	55
Figure 12. Effects of high and low discharges on bed changes without the control structure (a) and with the structure (b).....	57
Figure 13. Effects of low discharges (a) and high discharges (b) on bed changes, both with and without the structure.....	57

Hydraulic and Sediment Analysis for Panther Slough, Sanganois Conservation Area

ABSTRACT

The Illinois State Water Survey¹ (ISWS) and the Illinois Department of Conservation¹ (IDOC) conducted a joint investigation of possible sedimentation conditions if a water control structure is built at the junction of Panther Slough and Chain Lake at the Sanganois Conservation Area in Mason County, Illinois. The IDOC will operate this structure to manage water levels in Chain Lake from June to December of each year. The study also determined design criteria for the control structure to match desirable sediment sluicing in Panther Slough with operational rules. This report describes the study results and outlines final recommendations by the ISWS.

INTRODUCTION

The Sanganois Conservation Area, located in Cass and Mason Counties approximately two miles north and eight miles west of Chandlerville, Illinois, is managed by the Illinois Department of Conservation (IDOC) primarily for waterfowl. The site is broken into numerous waterfowl management units within which water level management and hunting practices vary. One of the larger units is Chain Lake, which is bounded by Chain Lake levee on the south, Stewart Lake levee on the north, Knapp Island on the east, and numerous unnamed land bodies on the west. Figure 1 shows the location of the Sanganois Conservation Area.

Normal drainage for Chain Lake is through Panther Slough, which is located at the west end of the lake and enters the Illinois River at River Mile (RM) 98.8 in the La Grange Pool. At one time a water control structure was built at the junction of Chain Lake and Panther Slough to manage water levels on the lake, but it was removed for what

¹ As of July 1, 1995, the IDOC and ISWS are part of the newly formed Department of Natural Resources.

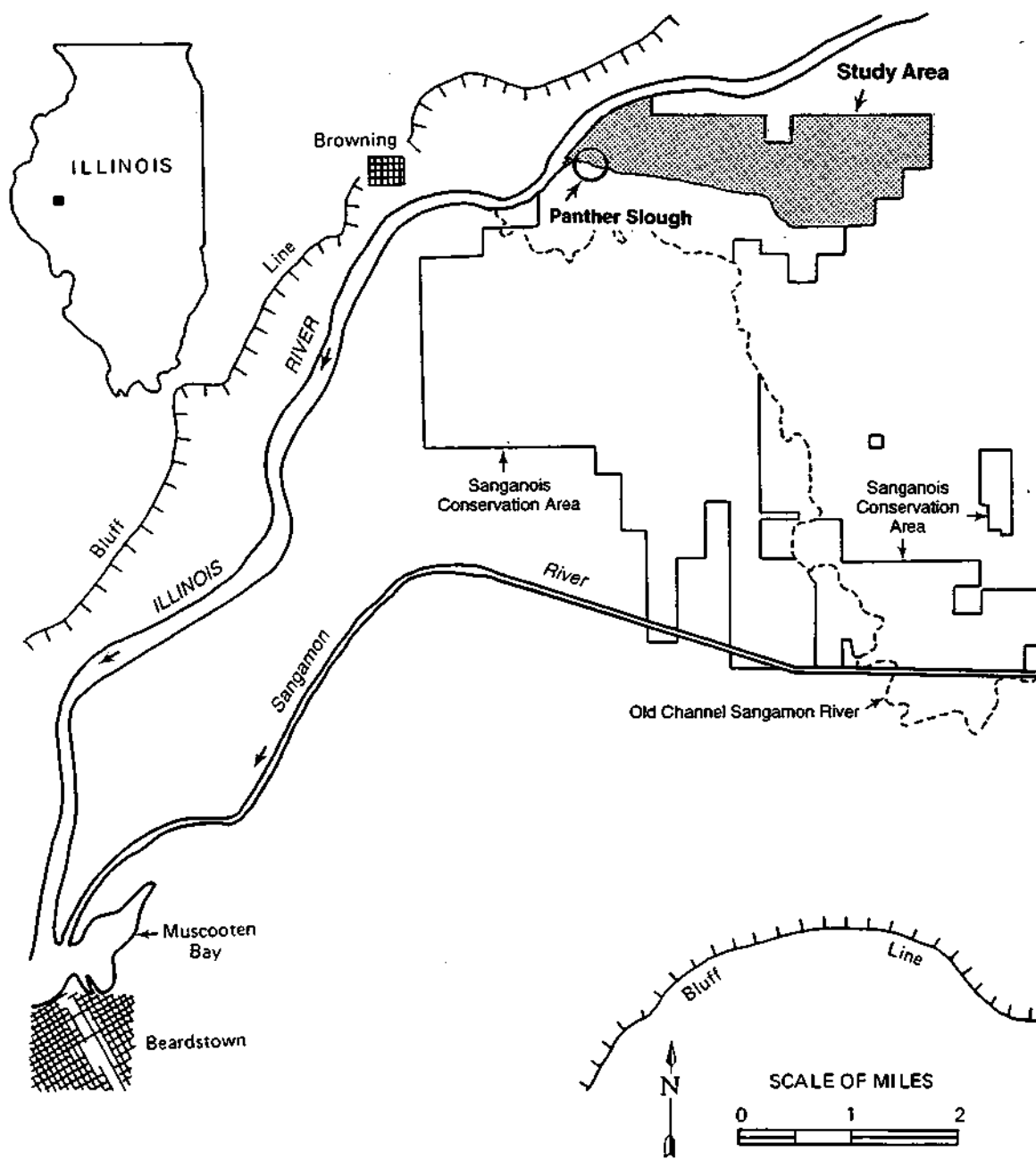

Figure 1. Sanganois Conservation Area

is believed to be two reasons: (1) boat access was required across Chain Lake to reach the Crane Lake unit, and (2) siltation may have begun in Panther Slough. Figure 2 shows the old structure site.

Because siltation in Chain Lake has reached a point where boat access to Crane Lake is no longer viable, the IDOC has constructed alternative boat access to Crane Lake. Water level management of Chain Lake is very desirable in terms of solidifying sediments, promoting the growth of moist soil plants, exposing mudflats to birds, and providing adequate water depths for waterfowl hunters. Therefore, it is necessary to reinstall a water control structure across Panther Slough.

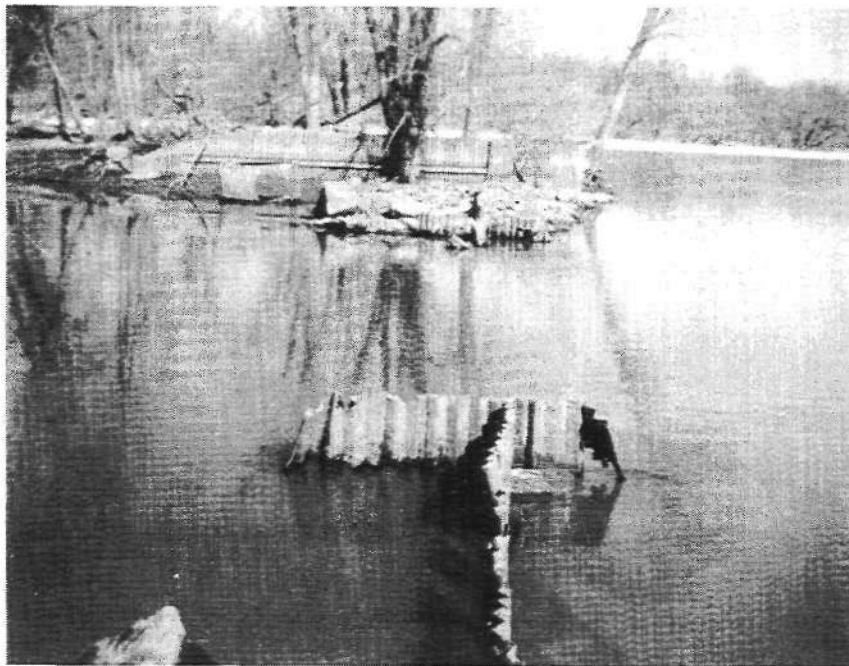

Figure 2. Old control structure

Study Objectives

To meet management needs, the water control structure should serve the following purposes:

1. Maintain Chain Lake water levels at 429 to 430 feet (ft) above mean sea level (MSL) in the summer and 432 to 433 ft in the fall.
2. Keep minor Illinois River fluctuations from raising or lowering water levels in Chain Lake from June to December of each year.
3. Prevent siltation in Panther Slough.

Currently a pump with a pumping rate of 40,000 gallons per minute (89.1 cubic feet per second or 25 cubic meters per second) is located near the junction of Chain Lake and Panther Slough. With the operation of this pump, a closure structure can serve purposes (1) and (2) above but cannot prevent siltation in Panther Slough, as siltation is likely to occur when there is no or little flow to the Slough. During these times, Panther Slough is subjected to the backwater effects of the Illinois River, which allow sediment-laden water to enter the Slough, causing sediment deposition. Alternatively, culverts with control gates can be used. However, siltation can still happen in Panther Slough during low flows. Instead of frequent dredging, flow itself can be used to sluice the sediment deposited in Panther Slough. Given the proper culvert dimensions, sufficient flows can be developed under given headwater elevations to flush out freshly deposited sediments. It is necessary to investigate what kind of flows can be developed and the feasibility of sluicing sediment with given flows. The objective of the Illinois State Water Survey (ISWS) investigation is therefore to determine the hydraulic and sediment patterns in Panther Slough after a control structure is installed. These analyses will, in turn, serve as design criteria for the control structure.

Study Approach

Natural flow and sediment conditions in Panther Slough had to be determined before structural impacts could be assessed. By analyzing existing data along with data collected for the project, the ISWS staff gathered information on average monthly flows, maximum design discharge, sediment sizes and distributions, current channel geometry, and the sources of sediment. An evaluation of whether scouring or sedimentation would occur was done by first examining the tractive force of the flow and critical shear stress for moving the sediment in the Slough. Then an HEC-6 numerical model was set up to simulate the flow and sediment patterns in Panther Slough before and after the structure is installed. Investigations also extended to seasons when gates are open, to explore opportunities for maintaining or enhancing natural flow conditions during the unregulated period from January to May.

Acknowledgments

This project was conducted under the administrative guidance of Dr. John O'Connor, former Chief, and Dr. Nani Bhowmik, Hydrology Division Head, Illinois State Water Survey. Financial support for the study was provided by the Illinois Department of Conservation. (As of July 1, 1995, both ISWS and IDOC are part of the newly formed Department of Natural Resources.) Ms. Kim Gibbson handled the project grant, and Mr. Robert Roads is the project manager.

The cooperation and assistance of Mr. Dan Cowen, Chief Officer at the Sanganois Conservation Field Station, in conducting the field survey are greatly appreciated. The authors also wish to thank Mr. Steve Stenzel of the Illinois Natural History Survey's Forbes Biological Station in Havana, and Mr. Bill Conner, U.S. Army Corps of Engineers, Rock Island District, for providing background data. Mr. Ronald Wright, IDOC, surveyed the elevations and width of the control structure, and Mr. Dick Mann, also of IDOC, assisted with a survey in July 1995. Illustrations were prepared by Linda Hascall

and Dave Cox; Lacie Jeffers prepared the camera-ready copy of the report; and Sarah Hibbeler edited the report.

BACKGROUND INFORMATION

Description of the Study Area

Chain Lake and Panther Slough are just two of many water units in the Sanganois Conservation Area. Figure 3 depicts Chain Lake and Panther Slough, along with the adjacent lakes and a tributary. Upstream of Chain Lake is Stewart Lake, which is divided by a service road into East and West Stewart Lakes; only West Stewart Lake is connected to Chain Lake. Although Chain Lake does not have any major inflow tributaries except for backwater from the Illinois River through Panther Slough, West Stewart Lake does have a major inflow tributary, Snicarte Slough. Illinois River water can enter West Stewart Lake through the East Branch of the Illinois River and Patterson Bay (figure 3). The lake enters the East Branch of the Illinois River at 113.3 RM, before it passes through Patterson Bay and re-enters the Illinois River at RM 106.7. (River miles on the Illinois River start in Grafton, Illinois, at the junction with the Mississippi River.)

The following dimensions are derived from U.S. Geological Survey (USGS) quadrangle maps:

Table 1. Dimensions of Water Bodies in the Study Area

<i>Water body</i>	<i>Length, ft</i>	<i>Width, ft</i>
Panther Slough	2,975	70~100
Chain Lake	6,700 (max.)	2,880 (max.)
West Stewart Lake	11,500 (max.)	3,800 (max.) 640 (at mouth of Snicarte Slough)

Depths for Panther Slough and adjacent lakes cannot be determined from the maps. On an aerial map provided by IDOC, the width of the Slough varies approximately between 70 and 100 ft (21.3 to 30.5 meters, m). The ISWS conducted three field surveys during the project to obtain the depths in Panther Slough and to verify the geometry velocity and sediment data in the Slough.

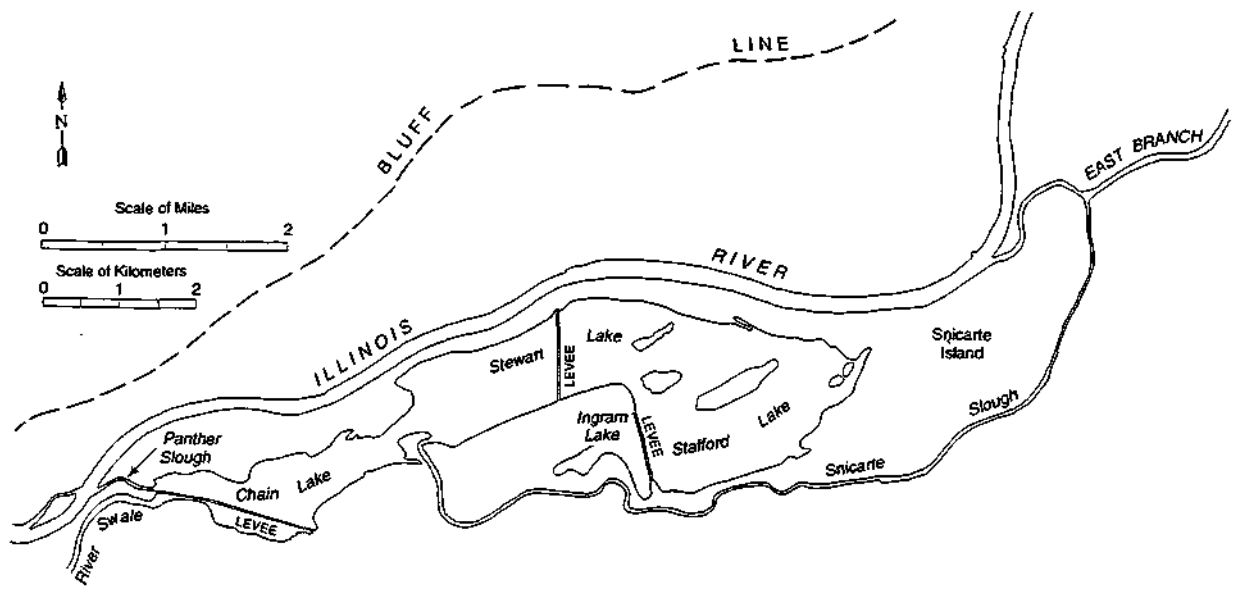

Figure 3. Chain Lake, Panther Slough, and adjacent lakes

The cross-sectional data were determined during a field survey on November 13, 1994. Five cross sections were surveyed, and their locations are presented in figure 4. Panther Slough drains into the Illinois River at RM 98.8, about 18.6 miles upstream from the La Grange Locks and Dam (L&D) at RM 80.2. There is also a small slough that enters Panther Slough from the north. This slough, Hickory Slough, has been silted, and very little flow can be conveyed except during floods. The field surveys also verified this situation.

Available Data

Illinois Natural History Survey Data

The Forbes Biological Station of the Illinois Natural History Survey (INHS) at Havana collected samples in Chain Lake from September 1989 to April 1993. Samples were collected from two locations in the lake, INHS codes I099.4C and I099.4D (figure 4), just upstream of Panther Slough. Two types of data are available (courtesy of Steve Stenzel, INHS): water quality data, including dissolved oxygen, pH, turbidity, conductivity, and water temperature; and hydraulic data, including water depth, flow velocity, and flow direction. Data were collected approximately two to seven times each month. The station stopped collecting these data in April 1993, because of the 1993 Flood, and data collection at these locations has not resumed because the water depth has become too shallow.

Illinois State Water Survey Data

As mentioned earlier, the ISWS conducted three surveys between September 1994 and July 1995 to determine the channel geometry, flow velocity, suspended sediment concentration, and bed material characteristics. These data will be presented later in the report.

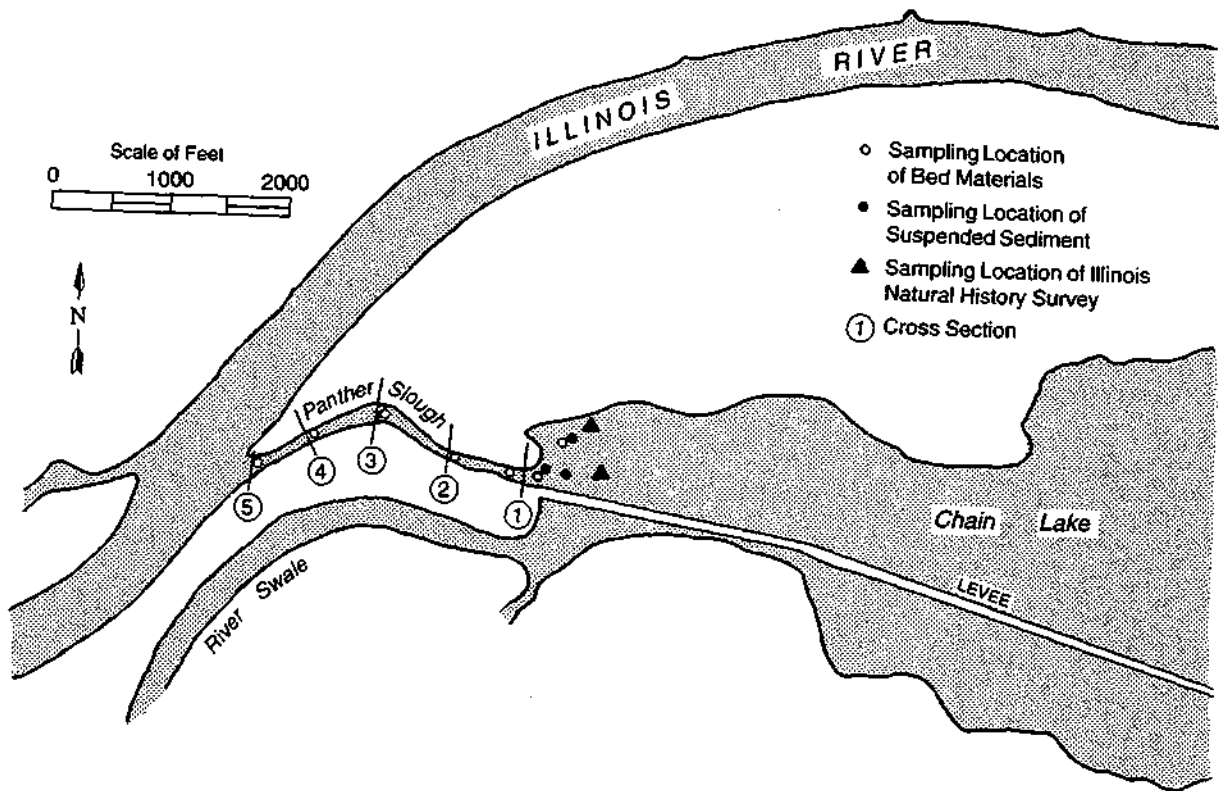

Figure 4. Surveyed cross sections on Panther Slough

River Stage and Discharge Data

The U.S. Army Corps of Engineers (USACOE)-Rock Island District maintains long-term stage records at locks and dams above the La Grange Pool on the Illinois River. Pool elevations at La Grange L&D (RM 80.2) and the tailwater elevation at Peoria L&D (RM 157.9) are used to interpolate river stages at the mouth of Panther Slough and at the entrance to the Illinois River's East Branch. Discharge data at Kingston Mines (RM 145.4) and Valley City (RM 61.4) are available from the USGS for the periods 1939 to 1993 and 1979 to 1993, respectively. These data are used to interpolate discharges to the East Branch of the Illinois River.

Precipitation Data

There are three weather stations in Mason County. Two are operated by the National Weather Service and located at Havana and Mason, respectively. The third one has been operated by the ISWS since January 1989, and it is located at Kilbourne, approximately 10 miles northeast of Chain Lake.

HYDROLOGY, HYDRAULICS, AND SEDIMENT IN THE STUDY AREA

The study area is located in a low-lying area. Given the area's proximity to the Illinois River, flows in Panther Slough can go either direction depending on the relative water level (stage) in Chain Lake and the Illinois River: water flows from Chain Lake to the Illinois River when the lake level is higher, and vice versa. Depending on the relative differences in stages, different flow patterns can develop. Flows in the Slough will be slow when the differences are nominal, and then sediment deposition is likely to occur in Panther Slough. The recurrence frequencies of such flow conditions are likely to be higher than those of natural conditions when the installed structure is closed for lake management. In order to determine the volume of flows through Panther Slough and possible sediment conditions, the hydrology, hydraulics, and sediment conditions of the study area need to be analyzed.

Hydrology

Regional precipitation, lake evaporation, flow diversions from the Illinois River to Snicarte Slough, and differences in surface elevations between Chain Lake and the Illinois River all affect flows in Chain Lake and hence in Panther Slough. These factors are analyzed to determine the hydrology of the study area.

Lake Elevation

The normal water surface elevation in East Stewart Lake (figure 3) is 433 ft above MSL. However, the elevation in West Stewart Lake and Chain Lake is variable due to connections to the Illinois River, either from Panther Slough or from Snicarte Slough. Furthermore, due to the low natural levees (approximately 434 to 435 ft above MSL) on the east side of Chain Lake, floodwater from the Illinois River can overtop the levees and submerge the lakes.

USGS quadrangle maps show that the normal East Stewart Lake elevation is 433 ft. At the mouth of Panther Slough (RM 98.8 on the Illinois River), the long-term average annual water surface elevation (from 1940 to 1993) is 432 ft. Following are the Illinois River stages at RM 98.8 for floods with various recurrence frequencies (from USACOE-Rock Island District):

2-year	440.6 ft
5-year	444.6 ft
10-year	447.2 ft
25-year	449.6 ft

Given that the bank elevation along the east side of the Illinois River is just 435 ft, it is clear that a flood with a return frequency less than two years can easily overtop the river banks and submerge the lakes. Once this happens, the whole area becomes a flow-through portion of the Illinois River, and the proposed water control structure will not function. The flooding situation is not in the scope of this study. The present investigation focuses only on unsubmerged conditions.

Drainage Area

Since the investigation considers unsubmerged conditions, a drainage area for Chain Lake is measured. The drainage area is defined by the levee or roads to the north and west and a 350-ft contour to the east, and covers Panther Slough, Chain Lake, West Stewart Lake, and Snicarte Slough. The total drainage area for Chain Lake is 7.4 square miles.

River Stages

The river stages at RM 113.3 (entrance to the East Branch of the Illinois River) and 98.8 (mouth of Panther Slough) are needed for the study. Even though there are no direct records at RM 98.8 and 113.3, the stages can be reasonably estimated by interpolating the pool water elevation data at La Grange L&D (RM 80.2) and the tailwater elevation at Peoria L&D (RM 157.9). Pool and tail elevations were provided by USACOE-Rbck Island District. Because the La Grange Pool is a fairly flat pool, it is reasonable to use linear interpolation for obtaining stages between two known stations. Table 2 shows the calculated average monthly stages at these two locations using 54 years of data (1940 to 1993).

Table 2. Calculated Monthly Stages (in ft) at RM 98.8 and RM 113.3

<i>River mile</i>	<i>Jan</i>	<i>Feb</i>	<i>Mar</i>	<i>Apr</i>	<i>May</i>	<i>Jun</i>	<i>Jul</i>	<i>Aug</i>	<i>Sept</i>	<i>Oct</i>	<i>Nov</i>	<i>Dec</i>
98.8	431.6	432.1	433.6	434.7	434.3	432.6	431.6	430.5	430.4	430.6	430.9	431.4
113.3	432.9	433.4	435.2	436.3	435.7	434.0	432.7	431.4	431.2	431.4	431.8	432.6
Difference	1.3	1.3	1.6	1.6	1.4	1.4	1.1	0.9	0.8	0.8	0.9	1.2

Given the higher stages at RM 113.3, sufficient flows can be diverted to the East Branch, Snicarte Slough, West Stewart Lake, through Chain Lake, Panther Slough, and then re-enter the Illinois River. The flows are higher from December to June and lower from July to November. Note that table 2 only describes the monthly average stages, or general conditions. Daily stages can have greater variations due to flood passages or local precipitation, for example.

Precipitation

Since the ISWS' Kilbourne station is near Chain Lake, precipitation data from this site are used to represent the Chain Lake area. Table 3 lists the average monthly precipitation from five years of data (1989 to 1993).

Table 3. Monthly Precipitation (in inches) at Kilbourne Station

<i>Jan</i>	<i>Feb</i>	<i>Mar</i>	<i>Apr</i>	<i>May</i>	<i>Jun</i>	<i>Jul</i>	<i>Aug</i>	<i>Sept</i>	<i>Oct</i>	<i>Nov</i>	<i>Dec</i>
1.38	1.72	2.14	2.33	3.75	3.45	6.13	3.05	5.03	3.14	3.47	1.80

Determination of Discharges from Chain Lake to Panther Slough

Discharge data from Chain Lake to Panther Slough are needed to determine the culvert design. Currently there are neither existing data on discharge nor a method for estimating discharge from Chain Lake to Panther Slough. Discharge can be calculated using velocity data collected by the INHS at Cham Lake or by developing a method to determine the outflow discharges for Chain Lake based upon historical stage and precipitation data. These discharges are calculated as daily averages over a whole month.

Calculating Discharge from Existing Velocity Data

Discharge can be calculated from the velocity measurements taken by INHS at the entrance to Panther Slough. The formula for calculating discharge using the standard USGS method (Buchanan and Somers, 1969) is:

$$Q = \sum q_x$$

and

$$q_x = a \cdot v = v_x \left[\frac{b_{(x+1)} - b_{(x-1)}}{2} \right] d_x \quad (1)$$

where Q is the overall discharge, q_x is the discharge through partial subsection x , a is the cross-sectional area, v is the mean velocity in a , v_x is the mean velocity at location x , b_x is the distance from an initial point to location x , $b_{(x-1)}$ is the distance from an initial point to the preceding location, $b_{(x+1)}$ is the distance from an initial point to the next location, and d_x is the depth of water at location x .

In order to use this method, velocity is measured at subsections that equally divide the river; 10 to 15 intervals are needed for a large cross section. The INHS velocity measurements were made only at two vertical stations, however, and the cross-sectional geometry was not recorded. In order to use equation (1) to calculate the discharge, the cross-sectional area has to be determined. The cross section is assumed to be trapezoidal, with pivot points at two stations where depths are known. The top width is then

estimated by measuring the USGS quadrangle map (1981). Assuming the datum did not change over the period of measurement, the discharge can then be estimated from measured velocity and interpolated areas. This formula calculates instantaneous discharge, which is then assumed to be equal to daily discharge.

Given the scattered nature of the data (about two to seven measurements in a month), daily discharge data cannot really provide more useful information than monthly discharge data. To calculate the monthly average discharge, those days without measurements are assigned the calculated daily discharge from neighboring days. Then one can calculate the sum of daily discharges and divide it by the number of days in a month. At times equation (1) yielded negative discharge values, which means that the water flowed from the Illinois River to Chain Lake. Negative discharges occur most frequently in June, July, September, and October.

Table 4 shows the calculated average daily discharge (Q) for each month during the INHS study (September 1989 to April 1993).

Table 4. Monthly Discharges (in cfs) from Chain Lake to Panther Slough

<i>Year</i>	<i>Jan</i>	<i>Feb</i>	<i>Mar</i>	<i>Apr</i>	<i>May</i>	<i>Jun</i>	<i>Jul</i>	<i>Aug</i>	<i>Sept</i>	<i>Oct</i>	<i>Nov</i>	<i>Dec</i>
1989									1,622	198	118	92
1990	332	449	2,316	745	1,341	940	955	478	323	347	454	2,308
1991	-	757	1,379	1,661	1,153	972	212	62	76	222	516	948
1992	533	683	646	433	532	145	719	750	373	299	591	587
Average	433	630	1,447	946	1,009	686	628	430	598	267	420	984

Note: To obtain discharge in cms, multiply the discharge in cfs by 0.0283.

In general, discharge is low in January and February and from July through November, and higher in March, April, May, and June. This trend is comparable to the differences in long-term monthly mean stages between RM 113.3 and RM 98.8, analyzed earlier (table 2).

The INHS data include both flooding (stage above 435 ft) and nonflooding conditions. To make the data useful for the present study, data above flood stage need to be removed. This can be done by examining corresponding daily stages of the Illinois

River at RM 98.8 (stages at RM 113.3 were consistently higher). If the stage at RM 98.8 was higher than 435 ft, then the INHS measurement for that month was removed. Table 5 shows the monthly average water surface elevation at RM 98.8, while table 6 presents the revised monthly discharges from Chain Lake to Panther Slough on the basis of the INHS data.

Table 5. Monthly Water Surface Elevations at RM 98.8

<i>Year</i>	<i>Jan</i>	<i>Feb</i>	<i>Mar</i>	<i>Apr</i>	<i>May</i>	<i>Jun</i>	<i>Jul</i>	<i>Aug</i>	<i>Sept</i>	<i>Oct</i>	<i>Nov</i>	<i>Dec</i>
1989									432.3	430.1	430.2	430.0
1990	431.0	431.8	437.4	432.1	436.2	437.3	436.4	431.7	430.4	430.9	431.4	N/A
1991	436.6	435.4	436.0	437.6	437.5	434.0	430.0	429.8	429.7	430.2	430.9	432.1
1992	430.7	431.0	430.9	431.2	430.5	430.0	430.9	431.1	430.8	430.1	434.3	435.7
Average	432.8	432.7	434.8	433.6	434.7	433.8	432.4	430.9	430.8	430.3	431.7	432.6
Long-term average	431.6	432.1	433.6	434.7	434.3	432.6	431.6	430.5	430.4	430.6	430.9	431.4

Note: Long-term averages calculated using data from 1940 to 1993. N/A indicates missing data.

Table 6. Monthly Discharge (in cfs) from Chain Lake to Panther Slough under Nonflooding Conditions

<i>Year</i>	<i>Jan</i>	<i>Feb</i>	<i>Mar</i>	<i>Apr</i>	<i>May</i>	<i>Jun</i>	<i>Jul</i>	<i>Aug</i>	<i>Sept</i>	<i>Oct</i>	<i>Nov</i>	<i>Dec</i>
1989									*	198	118	92
1990	332	449	*	745	*	*	*	478	323	347	454	*
1991	*	*	*	*	*	972	212	62	76	222	516	948
1992	533	683	646	433	532	145	719	750	373	299	591	*
Average	433	566	646	589	532	559	466	430	257	267	420	520

*Note: Discharge corresponding to a stage in the Illinois River is higher than 435 ft above MSL.

It can be seen from table 6 that the maximum calculated discharge is around 972 cfs.

Estimating Discharge from Flow Diversions

A functional relationship can be established for predicting discharge from Chain Lake by considering factors such as stage, precipitation, and evaporation. If this relationship can be defined, a relatively long-term estimate of discharge from Chain Lake can be analyzed given the available records for stage and precipitation.

On the basis of mass balance, the discharge (Q) flowing from Chain Lake is equal to inflow from Snicarte Slough minus losses. A general form of this description can be written as

$$Q_{out \text{ from Chain Lake}} = Q_{in \text{ from Snicarte Slough}} + \text{Precipitation} - \text{Evaporation} \quad (2)$$

Seepage and infiltration to ground water are ignored because such information is not available. They can be assumed to be reasonably small. In equation (2), precipitation data are known, and evaporation can be estimated by a formula derived by Roberts and Stall (1967):

$$E_L = \{ \exp[(T_a - 212)(0.1024 - 0.01066 \ln R)] - 0.0001 + 0.0105(e_s - e_a)^{0.88} (0.37 + 0.0041 U_p) \} \times \{ 0.015 + (T_a + 398.36)^{-2} 6.8554 \times 10^{10} \exp[-7482.6 / (T_a + 398.36)] \}^{-1} \quad (3)$$

where E_L is the lake evaporation, in inches; T_a is the air temperature, in degrees Fahrenheit; e_a is the vapor pressure, in inches of mercury at temperature T_a ; e_s is the vapor pressure, in inches of mercury at temperature T_d ; T_d is the dew point temperature, in degrees Fahrenheit; R is solar radiation, in langleys per day; and U_p is the wind movement, in miles per day.

The only unknown variable in equation (2) is the Q_{in} from Snicarte Slough. Since flow in Snicarte Slough is diverted from the Illinois River, it can be reasonably estimated when the area is not submerged. The following procedures are developed for estimating inflow under conditions when the Illinois River stage is lower than 435 ft.

Estimating Q_{in} from Snicarte Slough. Discharge in Snicarte Slough comes from the East Branch of the Illinois River (at RM 113.3, see figure 3), which itself is a diversion from the main stem of the Illinois River. Therefore, the discharge to the East Branch must be determined before a similar procedure can be used to determine the discharge diverted to Snicarte Slough.

Because there is not a gaging station near the entrance to the East Branch of the Illinois River, an interpolation procedure for estimating discharge is needed. Two gaging stations near the study area —Kingston Mines (upstream at RM 145.4) and Valley City (downstream at RM 61.4) —record daily discharge data. Discharge at RM 113.3 can be reasonably estimated in proportion to the drainage areas, which are 15,818, 18,187, and 26,742 square miles for Kingston Mines, RM 113.3, and Valley City, respectively. The interpolation formula can then be stated as:

$$Q_{RM113.3} = Q_K + (Q_V - Q_K) \times (A_{RM113.3} - A_K) / (A_V - A_K) \quad (4)$$

where Q represents the discharge in cfs, A represents the drainage area in square miles, and subscript values are the abbreviations of the three locations.

After knowing the total discharge at RM 113.3, the amount of flow diverted to the East Branch of the Illinois River is calculated in proportion to the product of the cross-sectional areas and velocity between two channels at the junction of RM 113.3. In general, flow in the Illinois River is subcritical (tranquil flow, Froude number < 1), therefore the assumption is valid. To approximate the cross-sectional areas, one can assume that they both have trapezoidal shapes and the same side slopes, and that the normal depth is 10 ft at normal pool elevation. Therefore, the ratio of two cross-sectional areas is approximately 0.55 at a stage of 432 ft, and the top widths are 600 and 400 ft in the main stem and East Branch, respectively.

Vectors of flow are used to estimate the velocity component in each channel at RM 113.3. The angle of main flow axes between East Branch and the main stem is 45° before diversion. Therefore, the velocity in East Branch is approximately 0.5 that in the main stem after the diversion. Given these conditions, the discharge diverted to East Branch is approximately equal to area times velocity:

$$Q_{east\ branch} = 0.27 \times Q_{113.3\ before\ diversion} \quad (5)$$

Note that this relationship is developed under normal pool conditions, and coefficient 0.27 is developed under given assumptions. Calibration with INHS data suggests that the following coefficients can be used instead of 0.27 under various stages:

Range of stages:	430-431	431-432	432-433	433-434	434-435
Best-fit coefficient:	0.22	0.24	0.245	0.252	0.26

Similarly, the discharge diverted to Snicarte Slough from East Branch can be approximated by:

$$Q_{snicarte} = coef \times Q_{east\ branch} \tag{6}$$

where the coefficient can be any of the following values:

Range of stages:	430 - 431	431 - 432	432 - 433	433 - 434	434 - 435
Best-fit coefficient:	0.11	0.13	0.137	0.14	0.147

The development assumes top widths of 230 and 115 ft for East Branch and Snicarte Slough, respectively, at normal depths of 5 ft.

Contributions from precipitation account for direct increases in lake volume. Daily rainfall values are taken from the records at Kilbourne station. The increase in lake volume is converted to discharge by dividing the volume by time.

After incorporating all these data into equation (2), discharge from Chain Lake can be determined for a relatively long time. The calculated outflow discharges from Chain Lake from 1979 to 1992 are given in table 7. Figure 5 illustrates how these mean monthly flows varied over these years.

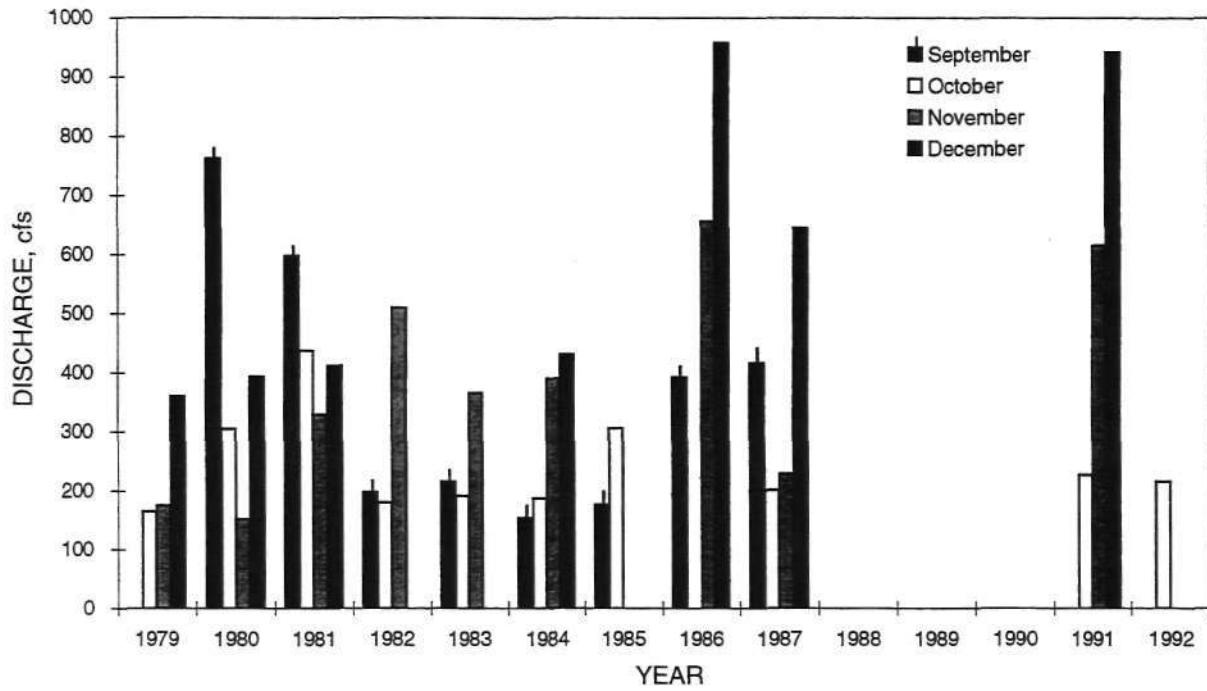

Figure 5. Monthly average discharges as calculated by the diversion method

Table 7. Calculated Discharge from Chain Lake under Nonflooding Conditions

<i>Year</i>	<i>Jan</i>	<i>Feb</i>	<i>Mar</i>	<i>Apr</i>	<i>May</i>	<i>Jun</i>	<i>Jul</i>	<i>Aug</i>	<i>Sept</i>	<i>Oct</i>	<i>Nov</i>	<i>Dec</i>
1979	N/A	N/A	N/A	N/A	N/A	N/A	N/A	N/A	N/A	165	175	361
1980	335	287	744	*	494	*	303	346	763	305	152	395
1981	203	348	457	*	*	*	*	*	598	439	331	413
1982	438	*	*	*	*	767	*	505	198	180	511	*
1983	*	715	748	*	*	726	522	188	216	192	367	*
1984	*	*	*	*	*	*	345	179	154	188	392	432
1985	740	696	*	*	426	241	197	215	177	307	*	*
1986	473	874	*	411	701	698	832	204	393	*	657	959
1987	402	512	403	544	542	466	188	441	418	202	229	645
1988	N/A	N/A	N/A	N/A	N/A	N/A	N/A	N/A	N/A	N/A	N/A	N/A
1989	N/A	N/A	N/A	N/A	N/A	N/A	N/A	N/A	N/A	N/A	N/A	N/A
1990	N/A	N/A	N/A	N/A	N/A	N/A	N/A	N/A	N/A	N/A	N/A	N/A
1991	N/A	N/A	N/A	N/A	N/A	N/A	N/A	N/A	N/A	227	616	943
1992	393	557	661	541	416	169	408	*	*	216	N/A	N/A
Average	426	570	603	499	516	511	399	297	365	242	381	593

* Discharge corresponding to a stage in the Illinois River is higher than 435 ft (MSL).

N/A: indicates missing data.

Determination of Maximum Discharge for Culvert Design

Table 7 shows that the average monthly mean discharge is highest in March and second highest in December. Since lake levels will be maintained between 432 and 433 ft from September to December, the capacity of the control structure must allow any high, nonflooding discharges in this period to pass through without holding water in the lake. The monthly mean discharges from 1979 to 1992 as determined by the diversion method reveal how, historically, high flows are distributed among these months. Figures 6a-6d plot the monthly mean discharge for September, October, November, and December, respectively. Years with missing data or flooding conditions are not presented. In each monthly plot, the average value over these years is represented by a horizontal line with associated standard deviation. Note that December has the highest discharges and most fluctuations. Therefore, the December discharge should be considered in the design.

The calculated discharges and corresponding downstream elevations can be further examined in figures 7a and 7b. Figure 7a shows the relationship between the discharges measured by INHS and the water surface elevations at RM 98.8. This figure indicates that when the water surface elevation at RM 98.8 is less than 435 ft, the discharge flowing

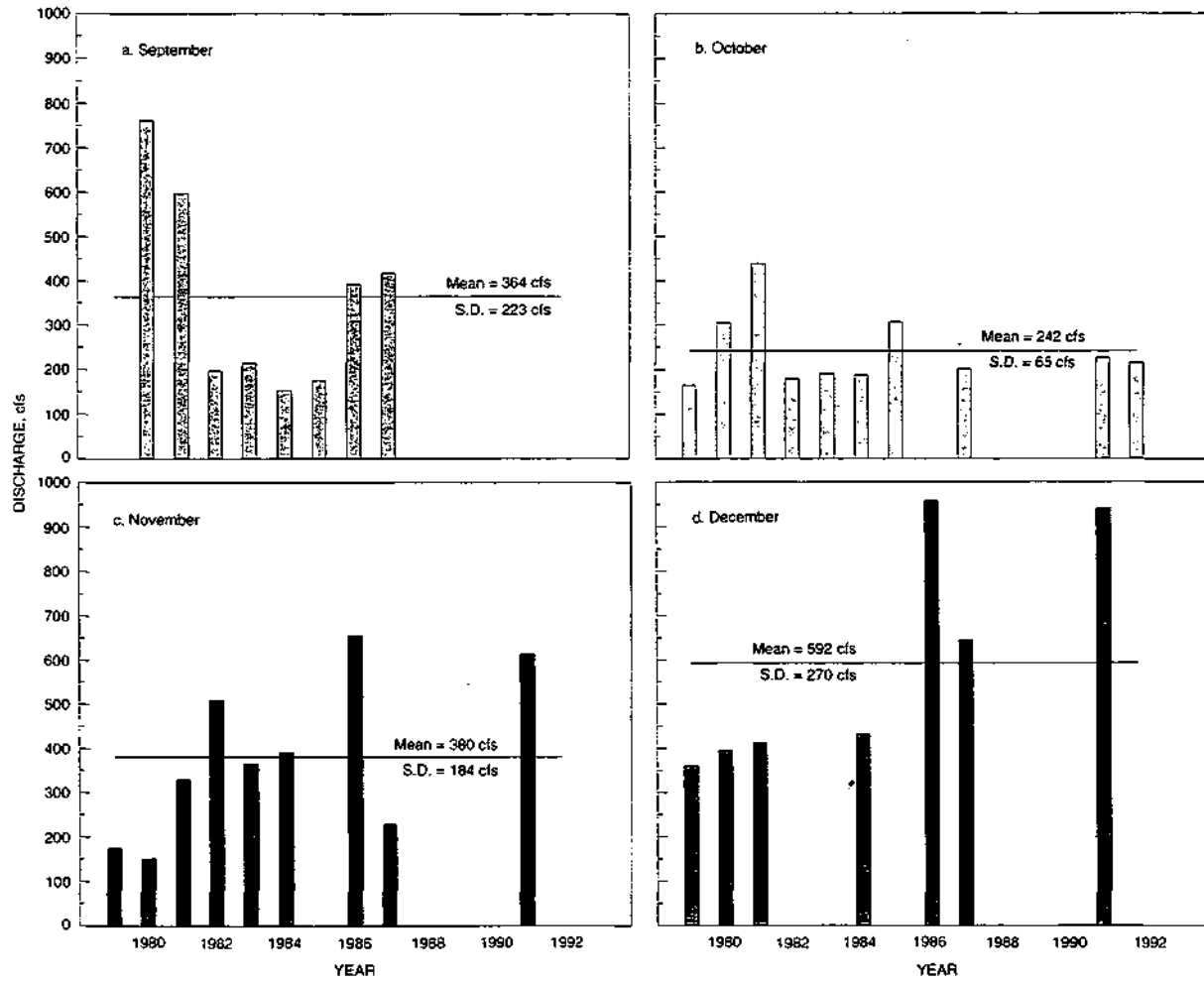

Figure 6. Average monthly discharge for September (a), October (b), November (c), and December (d) as estimated by the diversion method

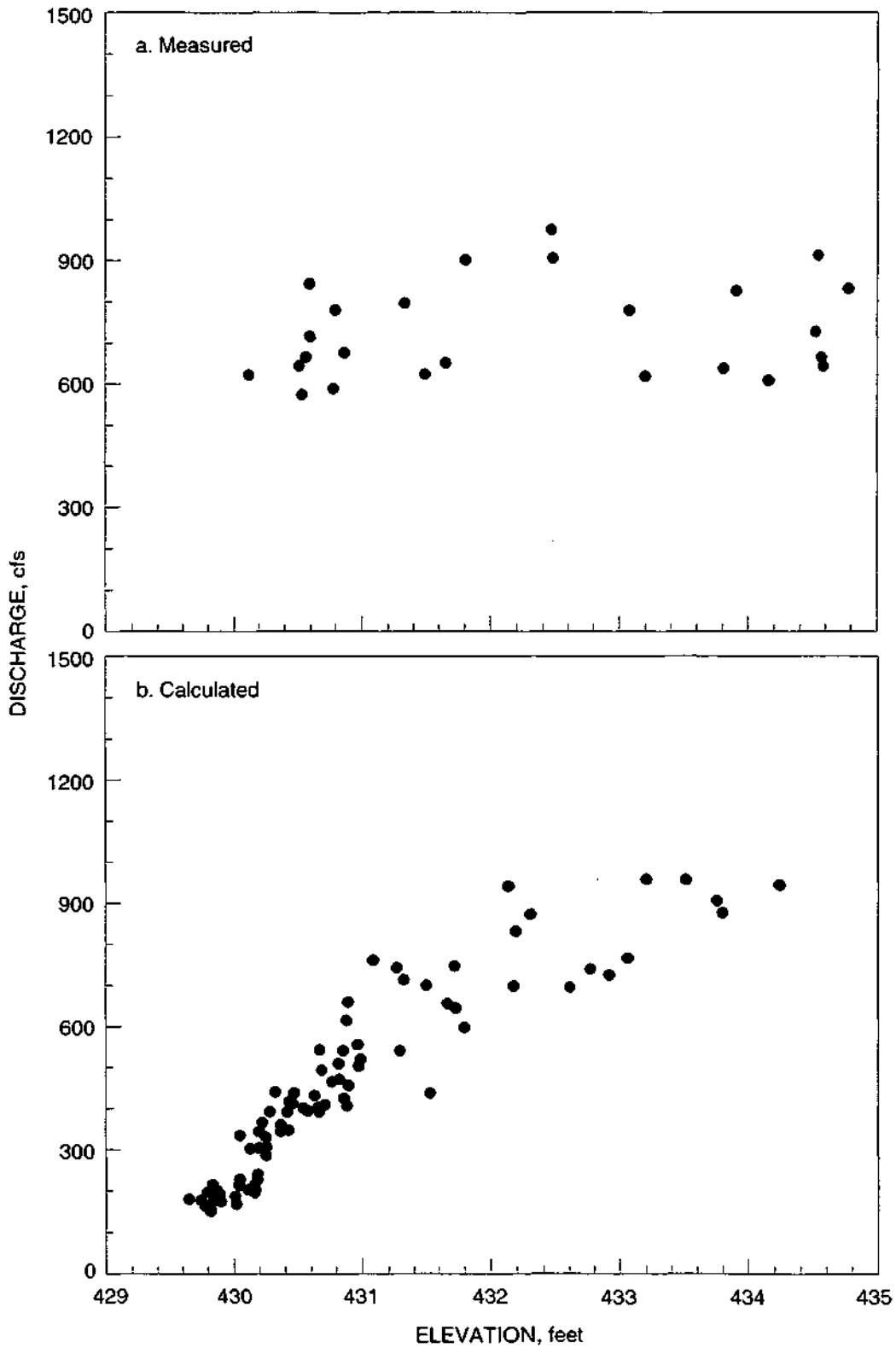

Figure 7. Relationship between water surface elevation at RM 98.8 and discharge measured by INHS (a) and discharge calculated by equation 2 (b)

through Panther Slough is approximately less than 972 cfs (27.5 cms) with a mean of 728 cfs (20.6 cms), and all larger discharges are created under high stage conditions. Figure 7b shows similar information for discharges calculated by equation (2). Under this condition, the maximum discharge is 959 cfs (27.2 cms) with a mean of 455 cfs (12.9 cms). The maximum nonflooding discharges as determined by the two methods — measured and calculated — are similar. Combining the two calculated discharges yields a maximum discharge from Chain Lake to Panther Slough of approximately 975 cfs (27.5 cms).

Hydraulics

It is necessary to know the ranges of flow velocity in Panther Slough to evaluate sediment transport and erosion or deposition in the channel. The hydraulic and sediment characteristics of the study area were determined by field data collection. Velocity was measured with a Marsh McBirney 201 one-dimensional electromagnetic current meter during field trips on November 16, 1994, and July 11, 1995. During the November trip, Chain Lake had high water elevations as a result of heavy rainfalls a week before. Flow velocities were measured at five cross sections (figure 4), which were at the entrance of the Slough, straight reaches, bend, and outlet. At these locations, channel profile and sediment depth were also measured. Velocity and water surface elevation were measured at the old water control structure, and were used to calculate discharges and water surface profiles. These measurements were repeated again in July 1995, following major spring flooding. Measurements from both trips are presented in table 8.

Table 8. Data Measured during Field Surveys

Location	November 1994				July 1995				
	AvgV (fps)	Width (ft)	Dw (ft)	Ds (ft)	AvgV (fps)	Width (ft)	Dw (ft)	Ds(ft)	
								left	right
CS 1	1.15		4.80		2.25	75	4.25	0.50	1.83
CS 2	1.42	90	3.89	2.5	2.27	80	3.83	2.33	0.25
CS 3	1.34	90	4.13		2.08	80	4.16	1.50	1.50
CS 4	1.42	90	3.91	2.0	2.65	75	4.03	1.50	1.50
CS 5	1.26	80	4.38		1.98	60	4.30	0.0	0.50

Notes: November 1994 discharge (Q) = 498 cfs. July 1995 discharge (Q) = 721 cfs.

CS = cross section; Dw = average depth of water for the cross section; V = velocity.

Width is the estimated distance from water edge to water edge. Left and right are based on the observer's looking in the downstream direction.

Sediment thickness in Panther Slough was approximately 2.0 ft (0.61 m), as measured on the field trip on September 13, 1994. The sediment depths were measured again at left and right banks (looking downstream) from cross sections 1 to 5 during the field trip on July 11, 1995 (table 8). Sediment thickness ranged from 0.25 ft (0.08 m) to 2.33 ft (0.71 m) at the area near the junction, then gradually decreased to 1.5 ft (0.46 m) toward the middle of Panther Slough (cross section 3), and decreased again to 0.5 ft (0.15 m) toward the mouth (cross section 5).

The old structure was used as a control section for determining discharge and water surface slope of the Slough. In addition to ISWS field measurements, Mr. Ronald Wright of JDOC also conducted a survey in July 1995. He confirmed that the elevation of the old pile sheet was 435.4 ft above MSL and the opening was 55 ft. The width from bank crest to bank crest at the structure site was 110 ft. Based on this information, the November 1994 survey had an average depth at the control section of 6.5 ft and a mean velocity (at a depth of 0.6 ft) of 1.7 feet per second (fps). Thus, the discharge from Chain Lake to Panther Slough was approximately 498 cfs (14.1 cms), and the water surface slope in Panther Slough was approximately 0.0001 ft/ft. For the July survey average depth was 8.1 ft and velocity at a water depth of 0.6 ft was 2.2 fps. Thus, the discharge and water surface slope were calculated as 721 cfs (20.4 cms) and 0.0002 ft/ft,

respectively. This information was used in checking tractive forces and in calibrating a numerical model for inferring velocities at other discharges.

Sediment Characteristics

Several ISWS studies have identified heavy sedimentation in the lakes and sloughs along the Illinois River (e.g., Demissie et al., 1992) and in the Sanganois Area (Lee, 1982). Aerial photos have shown significant delta formation at the outlet of Snicarte Slough in West Stewart Lake. During nonflooding periods, river water passes through the East Branch, through Snicarte Slough, and into West Stewart Lake. Flow velocity decreases when channel water meets the lake, and coarser particles are deposited at the outlet of Snicarte Slough. Lake currents carry fine sediment (clay and silt) farther down to Chain Lake and Panther Slough. The entrance to Panther Slough is narrower at the collapsed structure site. Flow is rapid, and the bottom is hard rock or old rip raps. Deposition can occur further downstream in Panther Slough, especially along both banks when the flow slows down, as shown by sediment depth (table 8). Another source of sediment in Chain Lake is flooding. Spring floodwaters on the Illinois are generally high in sediment. Significant sediment deposition may occur as floodwater recedes from the area. Some of this sediment may then be transported to Panther Slough during other storms.

In order to evaluate potential sedimentation in Panther Slough, it is necessary to know the composition of suspended sediment and bed material. During a field trip on September 13, 1994, three suspended sediment samples and three bed material samples were collected at locations (figure 4) upstream and downstream of the junction between Chain Lake and Panther Slough. The river was experiencing low flows in September. Suspended sediment concentration data were again taken in July 11, 1995, to represent post-flood conditions. The results of suspended sediment and bed materials analyses are summarized in tables 9 and 10, respectively.

Table 9. Suspended Sediment Concentration (in mg/l) in Panther Slough

<i>Location</i>	<i>Sept 13, 1994</i>	<i>Location</i>	<i>July 11, 1995</i>
#1S*	182.66	CS 1	209.83
#2S*	177.89	CS 2	221.05
#3S*	171.93	CS 3	234.92
Average	177.49	CS 4	295.37
		CS 5	442.34
	Illinois River Average		165.5

Notes: #1S: LHS upstream of the junction.
 #2S: Middle upstream of the junction.
 #3S: RHS upstream of the junction.
 Left-hand side (LHS) and right-hand side (RHS) are based on the observer's looking downstream.

Table 10. Composition of Bed Materials

<i>Date</i>	<i>Location</i>	<i>Percent finer than</i>				
		<i>0.031mm</i>	<i>0.016mm</i>	<i>0.008mm</i>	<i>0.004mm</i>	<i>0.002mm</i>
9/13/94	#1B*	66.6**	52.0	41.6	34.7	28.7
9/13/94	#2B*	95.3	83.3	65.7	53.0	43.5
9/13/94	#3B*	94.9	79.6	64.4	54.1	44.0
7/11/95	CS1	88.5	74.2	62.2	53.0	44.2
7/11/95	CS2	76.1	64.1	54.7	47.3	39.9
7/11/95	CS4	93.1	78.8	65.9	56.5	47.2
7/11/95	CS5	93.9	79.2	64.6	54.5	45.5

Notes:
 *#1B: Middle upstream of the junction.
 #2B: Upstream near the junction.
 #3B: Downstream near the junction.
 **Sample contains 25% fine sand, i.e., larger than 0.062 mm.

It should be noted that the suspended sediment sample at cross section 5 on July 11, 1995, was taken after a houseboat passed the site. This downbound houseboat generated large and prolonged waves at the shore. Even though the investigators waited about 10 minutes after the waves subsided before taking the sample, the concentration value still showed the effect of wave impacts. Another observation is that the suspended sediment concentration appears to be higher after the flood peak. Whether the difference is a seasonal effect is examined in table 11.

Table 10 indicates that the majority of bed materials are silt and clay in Chain Lake or Panther Slough, with some percentage of fine sand in Chain Lake upstream of Panther Slough (#1B). The sediment transport mechanism and load calculation for the fine materials would be different from those for medium or coarse sediments. An HEC-6 model described in a later section requires such information for selecting a proper transport function.

Using *Water Resources Data, Illinois, Water Years 1993 and 1994* (USGS 1993 and 1995), one can determine the monthly mean sediment concentration for the Illinois River at Valley City. Table 11 shows data for all months in 1993.

Table 11. Monthly Mean Sediment Concentration (in mg/l) at Valley City, 1993

<i>Jan</i>	<i>Feb</i>	<i>Mar</i>	<i>Apr</i>	<i>May</i>	<i>Jun</i>	<i>Jul</i>	<i>Aug</i>	<i>Sep</i>	<i>Oct</i>	<i>Nov</i>	<i>Dec</i>
103	66	208	57	96	280	69	51	162	104	133	103

The average suspended sediment concentration collected in September 1994 was close to the monthly mean value for September 1993 (table 11), but the average suspended sediment concentration measured in July 1995 was significantly larger than that for July 1993. This is one indication of how flooding can affect sedimentation in Chain Lake and Panther Slough.

Design Discharge for the Control Structure

The control structure is designed to operate under unsubmerged conditions, i.e., when flood stage is below 435 ft MSL. On the basis of previous analyses, the estimated maximum discharge under these conditions is 972 cfs (27.5 cms) from INHS data and 959 cfs (27.2 cms) from an interpolation method. The maximum design discharge for the control structure is reasonably set at 1,050 cfs (30 cms). This would allow the control structure to carry the discharge without causing overtopping under nonflooding conditions.

Consideration of Sedimentation Patterns

The installation of a control structure will modify flow patterns and hence sedimentation in Panther Slough. Sedimentation patterns need to be considered for operating the control structure at different times of year, as outlined below.

1. January to June, when the structure is open and under nonflooding conditions. Although the control structure is designed to pass the maximum nonflooding discharge, it is necessary to examine erosion/deposition in Panther Slough during this period to allow for changes in initial or boundary conditions.
2. July to December, when the structure is closed. During this period, flows in Panther Slough will be stagnant unless there are rises and falls in Illinois River stages. Deposition is likely to occur because there are no natural flows to carry out sediment. It is highly likely that water from the Illinois River will back into the Slough and produce sediment deposition in downstream sections of Panther Slough. Deposition is also likely to occur during floods. Although there is no analytical way to estimate how much deposition would be caused by backwater effects or by floods, an approximation can be made by analogizing annual sedimentation rates in backwater lakes along the Illinois River. A table summarizing estimated sedimentation rates in other parts of the Illinois River is presented in the appendix. (Based on the information provided, it is estimated that the sedimentation rate in Panther Slough is about 0.3 inches a year, or 0.15 inches for six months.)
3. January, or at other times when the highest head is developed in the Chain Lake side and the control structure has to be opened. This presents an opportunity to flush out freshly deposited sediment by flow forces. The amount of flows (forces) needed to carry the sediment varies both with the head differences upstream and downstream of the control structure and with the types of sediment. A range of possible conditions must be examined.

The assumption that there are sufficient flow forces to carry out sediment or to erode freshly deposited sediment must be examined before carrying out design and further analysis. An analysis of forces to be generated by natural flow is presented in the next section.

SEDIMENT TRANSPORT IN PANTHER SLOUGH

Transport of the sediment load in a channel is divided into two zones: the sediments moving in a layer close to the bed are referred to as the bed load, and those carried in the upper region of the flow are referred to as the suspended load. Both modes of transport are supported by forces produced through water flow. Sediment in Chain Lake and Panther Slough consists mostly of fine silt and clay. Whether silt or clay material is in transport or being deposited can be judged with a critical value for the bed shear stress (critical tractive shear stress). When the actual bed shear stress falls below the critical value, deposition occurs. The rate of deposition depends on stream velocity, fall velocity of the sediment grains, and suspended sediment concentration. Otherwise, silt and clay will remain in suspension through Panther Slough. A critical concentration for clay reported for other rivers is generally around 300 milligrams per liter (mg/l). Whether this sediment concentration is applicable to Panther Slough remains a topic for further investigation.

Critical Tractive Shear Stress

The force exerted by the flowing water on the channel bed in the direction of flow, and the force mainly responsible for the motion of the sediment particles, is called drag force or shear stress (i.e., force per unit surface area). A critical shear stress for a grain particle is the shear stress that causes incipient motion of the particle.

Shields (1936) was the first to study the beginning of sediment particle motion by considering the forces acting on the particle. After almost six decades, his results are still often quoted and widely used. For critical or incipient conditions, Shields' formula can be expressed as follows:

$$\frac{\tau_{\alpha}}{(\gamma_s - \gamma_w)d} = f(R_*') \quad (7)$$

where τ_{0c} is the critical tractive stress, d is the diameter of the sediment particle, γ_s is the specific weight of the sediment, γ_w is the specific weight of water, and $R_c^* = \frac{u_{*c} d}{\nu}$, where u_{*c} is the shear velocity at incipient motion and ν is the kinematic viscosity of water. Figure 8 shows the variation of $\tau_{0c}/(\gamma_s - \gamma_w)d$ with R_c^* as obtained by Shields based on experimental data. Additional data collected by Iwagaki (1956) after Shields' work are also plotted on this figure, which gives the values of τ_{0c} for different sediment particle diameters.

Yalin and Karahan (1979) used a large volume of data collected in recent years and developed the relation for critical tractive stress expressed as follows and shown in figure 9:

$$(R_c^*)^2 \frac{(\gamma_s - \gamma_w)d}{\tau_{0c}} = \frac{(\gamma_s - \gamma_w)d^3}{\rho_w \nu^2} \quad (8)$$

where ρ_w is the mass density of water. Using Yalin's and Karahan's curve for fully developed turbulent flow, one gets the values of τ_{0c} for different sediment particle diameters.

Table 12 summarizes the critical shear stress τ_{0c} calculated using Shields' and Yalin's and Karahan's formulas for bed material sizes ranging from 0.000079 inches (0.002 mm) to 0.0025 inches (0.063 mm) based on the data sampled in the field.

Table 12. Calculated Critical Tractive Stress in Panther Slough

<i>Formula used</i>	τ_{0c}
Shields	0.0001 ~ 0.0016 lbf/ft ² (0.005 ~ 0.076 N/m ²)
Yalin and Karahan	0.0002 ~ 0.0017 lbf/ft ² (0.010 ~ 0.082 N/m ²)

From tables 10 and 12, it is clear that a critical shear stress range from 0.0001 lbf/ft² (0.005 N/m²) to 0.0015 lbf/ft² (0.070 N/m²) is reasonable for Panther Slough. These values are very small. In addition to Shields' and Yalin's and Karahan's formulas, this study examined other existing formulas with which to check the tractive forces.

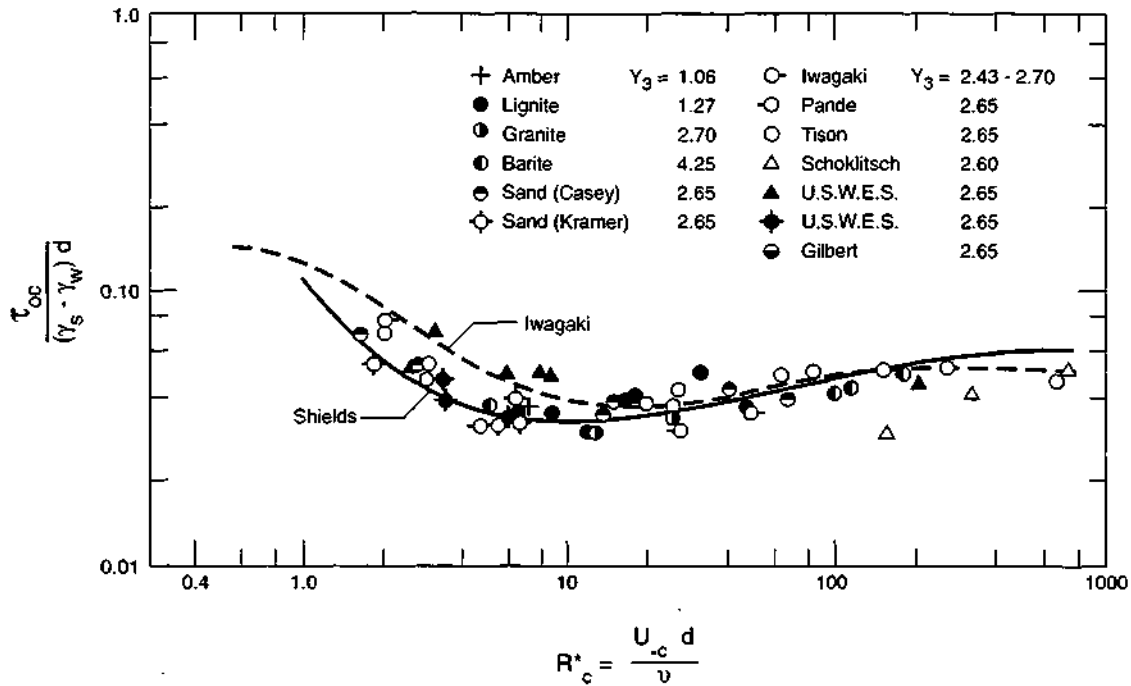

Figure 8. Variation of $\frac{\tau_{oc}}{(\gamma_s - \gamma_w)d}$ with R_c^* obtained by Shields (1936)

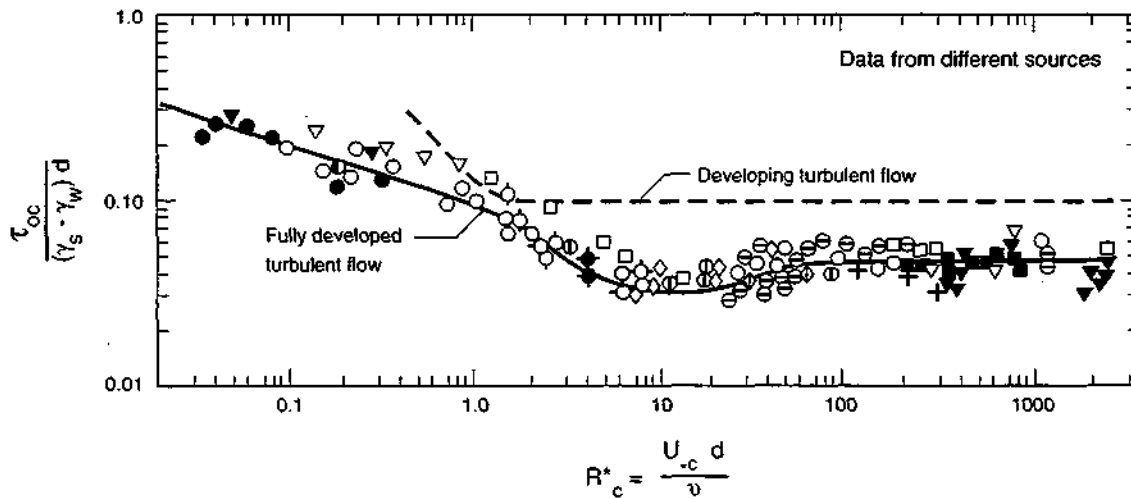

Figure 9. Variation of $\frac{\tau_{oc}}{(\gamma_s - \gamma_w)d}$ with R_c^* obtained by Yalin and Karahan (1979)

Empirical Formulas

Following are several equations considered for this study.

1. Krey's formula (Iwagaki, 1956). Proposes a relationship between τ_{oc} and d as

$$\tau_{oc} = \frac{0.754(\rho_s - \rho_w)d}{\rho_w} \quad (9)$$

where τ_{oc} is the critical tractive stress, ρ_s is the mass density of the sediment, ρ_w is the mass density of water, and d is the diameter of the sediment particles.

2. Indri's formula (Iwagaki, 1956) for critical tractive shear stress:

$$\begin{aligned} \tau_{oc} &= 0.130d\left(\frac{\rho_s - \rho_w}{\rho_w} \frac{1}{M}\right) + 0.12 \quad \text{for } d < 1.0\text{mm} \\ \tau_{oc} &= 0.538d\left(\frac{\rho_s - \rho_w}{\rho_w} \frac{1}{M}\right) - 0.73 \quad \text{for } d > 1.0\text{mm} \end{aligned} \quad (10)$$

where M is a uniformity coefficient.

3. Aki's and Sato's formula (Iwagaki, 1956):

$$\tau_{oc} = 0.546 \frac{(\rho_s - \rho_w)}{\rho_w} \lambda d \quad (11)$$

where λ is a parameter that depends on the size distribution.

4. Sakai's equation (Iwagaki, 1956):

$$\tau_{oc} = 0.327 \frac{(\rho_s - \rho_w)}{\rho_w} \beta d^{0.5} \quad (12)$$

where $\beta = (2+M)/(1+2M)$.

Theoretical and Semitheoretical Formulas

The above empirical formulas can yield an approximate value for critical tractive stress. The following formulas, including the two introduced earlier, are more theoretically based and more accurate for estimating the critical tractive shear stress.

1. Shields' (1936) formula (see equation 7).

2. White's (1940) formula:

$$\begin{aligned} \tau_{oc} &= \eta_1 \frac{\pi}{6} d(\gamma_s - \gamma_w) \tan \phi \quad \text{for high-speed case } (R_c^* > 3.5) \\ \tau_{oc} &= \alpha \eta_1 \frac{\pi}{6} d(\gamma_s - \gamma_w) \tan \phi \quad \text{for low-speed case } (R_c^* < 3.5) \end{aligned} \tag{13}$$

where η_1 is the packing coefficient, α is a coefficient, and ϕ is the angle of repose.

3. Yalin's and Karahan's (1979) formula (see equation 8).

4. Egiazaroff's (1965) formula:

$$\frac{\tau_{oc}}{(\gamma_s - \gamma_w)d} = \frac{4}{3C_d \{a_r + 5.75 \log(0.63)\}^2} \tag{14}$$

where $C_d = 0.4$ and $a_r = 8.5$ for large R_c^* , and C_d and a increase for low R_c^* .

Table 13 is a summary of the critical tractive shear stress calculated using some of the above equations. Because certain information about the bed materials, such as repose angle ϕ , packing coefficient η_1 , and drag coefficient C_d , is not available, equations (13) and (14) were not used in this study.

Table 13. Calculated Critical Tractive Stress in Panther Slough for Selected Equations

Formula used	τ_{oc}
Krey's formula	0.000052 ~ 0.000807 lbf/ft ² (0.0025 ~ 0.0386 N/m ²)
Indri's formula	0.002638 ~ 0.004524 lbf/ft ² (0.1262 ~ 0.2164 N/m ²)
Aki's and Sato's formula	0.000003 ~ 0.000040 lbf/ft ² (0.0001 ~ 0.0019 N/m ²)
Sakai's formula	0.000012 ~ 0.000317 lbf/ft ² (0.0006 ~ 0.0152 N/m ²)

Table 13 shows obvious differences in the values of τ_0 calculated using different equations. For the given hydraulic characteristics, the critical tractive shear stresses for the materials in Panther Slough can be said to range from 0.0001 lbf/ft² (0.0049 N/m²) to 0.0046 lbf/ft² (0.0221 N/m²).

Average Shear Stress

It is also necessary to examine the average flow forces in Panther Slough. Boundary shear stress is the stress exerted by water on the channel bed. It is generally calculated in terms of the hydraulic radius, the energy slope, and the specific weight of the water. In a wide natural channel, the water depth can replace the hydraulic radius, and the bed slope can replace the energy slope if the flow is a steady uniform flow. The average boundary shear stress for a channel is

$$\tau_0 = \gamma_w R S_e \approx \gamma_w D S \quad (15)$$

where τ_0 is the average shear stress, R is the hydraulic radius, S_e is the energy slope, D is the water depth, and S is the channel slope. Based on the measurements from the November 16, 1994, field trip, the average hydraulic radius R and the channel slope S for Panther Slough have been determined to be 4.17 ft (1.26 m) and 0.0001 to 0.00015, respectively. Thus, τ_0 calculated is equal to 0.03 lbf/ft² (1.4 N/m²), which is much greater than τ_0 estimated for Panther Slough; hence such a flow can transport or flush out the fine sediment from Panther Slough. Similarly, the τ_0 for the July 1995 trip is 0.05 lbf/ft² (2.4 N/m²), which is also greater than the critical shear stress determined. This examination illustrates the feasibility of flushing out sediment with certain flows. Whether the sediment can be flushed out under other flow conditions will be examined further.

CULVERT DESIGN

Although designing the culvert is not in the scope of this investigation, it is necessary to calculate the culvert dimensions for use in hydraulic and sediment analyses in Panther Slough. Based on previous analyses, the maximum design discharge to be used for the culvert is 1,050 cfs (30 cms). Considerations involved in selecting the culvert dimensions for this design discharge are as follows:

1. they should be available common commercial dimensions;
2. they must generate sufficient flow tractive forces for flushing sediment; and
3. should minimize disturbance to natural flow patterns when gates are open.

Given the high probability of flooding, the structure should also be designed to withstand overtopping conditions. A published software package, HY8, was used for calculating the dimensions of the culvert.

Culvert Hydraulics

According to Schwab et al. (1981), the possible conditions of flow through a culvert structure can be described as follows:

1. full: free outfall as pipe flow,
2. part full: free outfall as orifice flow,
3. full: outfall submerged as pipe flow,
4. inlet not submerged: conduit controls as open channel flows, and
5. inlet not submerged: inlet controls as weir flow.

Sketches of these flow patterns are shown in figure 10. The flow rate through various flow conditions is different. Under conditions (1) and (3), the flow rate is given by

$$Q = \frac{a\sqrt{2gH}}{\sqrt{1+k_e+k_eL}} \quad (16)$$

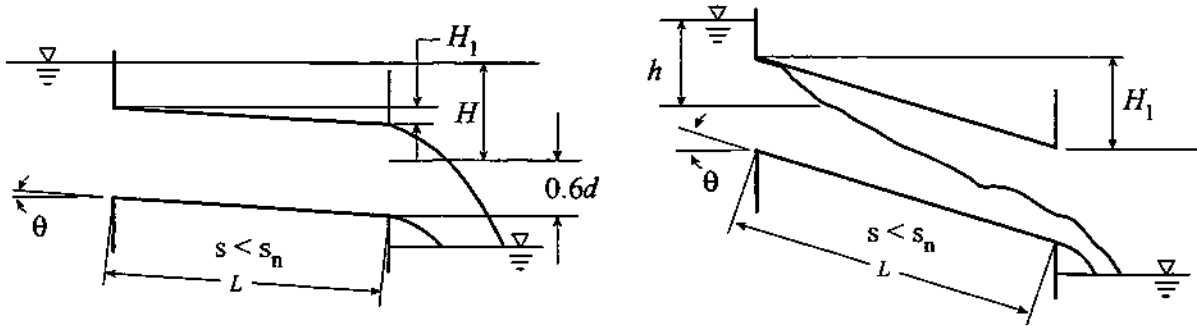

a. Full: free outfall, pipe flow

b. Part full: free outfall, orifice flow

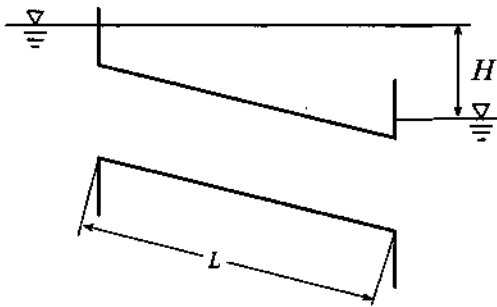

c. Full: outfall submerged, pipe flow

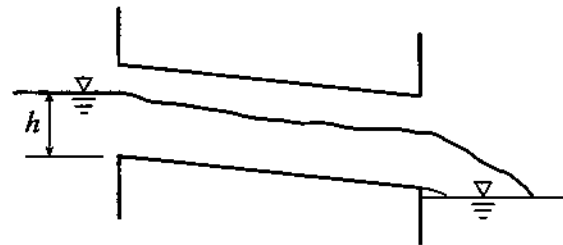

d. Inlet not submerged: conduit controls, open channel flows

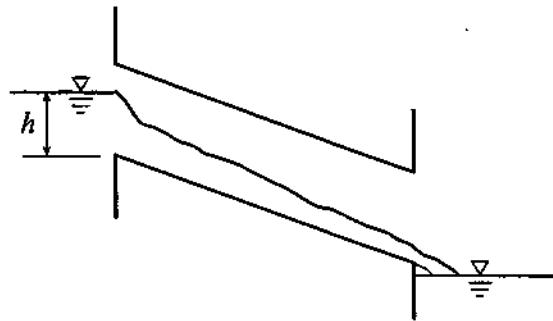

e. Inlet not submerged: inlet controls, weir flow

Figure 10. Possible conditions of flow through culverts (after Mavis, 1943)

where Q is the flow capacity, a is the cross-sectional area, H is the head causing the flow, L is the length of the control structure, and k_e is the entrance loss coefficient. For conditions (2), (4), and (5), capacity is given by

$$Q = ac\sqrt{2gh} \quad (17)$$

where c is the coefficient and h is the head to the center of the control structure.

A quick reference for the possible hydraulic head and tail elevations for this control structure is shown in table 14.

Table 14. Hydraulic Head under Management Plan (in ft)

<i>Elevation</i>	<i>June</i>	<i>July</i>	<i>August</i>	<i>September</i>	<i>October</i>	<i>November</i>	<i>December</i>
Designed head	429~430	429~430	429~430	432~433	432~433	432~433	432~433
Averages at RM 98.8	432.58	431.57	430.51	430.36	430.62	430.86	431.38
Available head	No	No	No	1.64~2.64	1.38~2.38	1.14~2.14	0.62~1.62

Determination of Culvert Size

The culvert size is determined using HY8 Version 4.0 software, which was developed by Philip L. Thompson and provided to the Federal Highway Administration (FHWA) for distribution. The software automates the design methods described in HDS No. 5, *Hydraulic Design of Highway Culverts*, dated September 1985, FHWA-IP-85-15; HEC No. 14, *Hydraulic Design of Energy Dissipators for Culverts and Channels*, dated September 1984; and HEC No. 19, *Hydrology*, dated October 1984, FHWA-IP-84-15. Using the HY8 program and assuming that

1. the pipe will be made by reinforced concrete with a normal value of k_s equal to 0.15 mm;
2. the gradient S is equal to 0.0001, which is close to the slope of Panther Slough (0.0001 to 0.00015 ft/ft);

3. the design discharge is equal to 30 cms; and
4. the culvert is circular-shaped;

the recommended culvert design is three pipes each with a diameter of 6.5 ft (1.98 m).

Based on the November 16, 1994, field survey, the bed elevation at the junction of Panther Slough and Chain Lake is 423.1 ft above MSL. Thus, after using a pipe culvert with diameter 6.5 ft, the crown elevation of the culvert is 429.6 ft above MSL. As demonstrated earlier, the average water surface elevation at RM 98.8 in the Illinois River is generally greater than 430 ft above MSL for all seasons. This means that the dominant outflow from the culvert is submerged under different downstream conditions. Thus, equation (17) will be used to calculate the outflow discharge from the culvert.

MODELING PANTHER SLOUGH

The HEC-6 Scour and Deposition in Rivers and Reservoirs model was selected for this study on the basis of its capabilities and the nature of the problems in Panther Slough. This numerical model is accepted widely by research and practicing engineers alike and has been applied to many field studies (Fan, 1988). However, it is a one-dimensional steady flow model with no provisions for simulating the development of meanders or specifying a lateral distribution of sediment load across a cross section (USACOE, 1977). It has several deficiencies in areas such as supercritical flows, local scour at bridge piers, and flow reversals. Although flow reversal and flooding will not be included in the model study, deposition associated with them has been discussed using analogies to nearby backwater lakes. This investigation uses a version of the HEC-6 model that contains a transport and resuspension equation for fine materials. This section provides a brief discussion of the basic equation involved in the HEC-6 model, along with the computational procedures, input data requirements, and limitations of the model. It then uses outputs from the HEC-6 model to predict sediment deposition in Panther Slough.

HEC-6 Model

HEC-6 is a one-dimensional flow and sediment transport simulation model designed for analyzing scour and deposition of sediment in rivers and reservoirs. It simulates the ability of a stream to transport sediment and computes the scour and deposition of sand, silt, and clay in streams and reservoirs. In its computations HEC-6 first performs water surface profile calculations in each modeled reach (between two cross sections), and solves a one-dimensional energy equation using a standard step method. This first step determines the basic hydraulic parameters needed to calculate sediment transport capacity, including velocity, depth, width, and slope. Then the program uses the hydraulic and sediment characteristics to compute the sediment transport in each study reach. A transport relationship must be specified for the study reach in order to calculate its transport capacity. The size of bed material and the dimension of the streams are some

of the considerations in selecting a proper transport relationship. After the transport capacity is known, the program calculates the sediment load, G , using sediment inflow, available bed material, and armoring. The basic equation used in the HEC-6 model is the continuity equation of sediment materials:

$$\frac{\partial G}{\partial x} + B \frac{\partial y_s}{\partial t} = 0 \quad (18)$$

where G is the sediment load, B is the width of deposition or scour area (movable bed), y_s is the depth of sediment deposition or scour above a stable layer, x is the distance along the channel, and t is the time. A movable bed in HEC-6 is that portion of the bed in which sediment depth can change in a cross section. Therefore a cross section is divided into two parts —the movable bed and that part which does not change —and the boundary between these parts remains fixed for the study.

Input Data Requirements

In order to run HEC-6 for a study reach, the geometry, flows, and sediment of the study reach have to be described. These are:

1. Geometric data: cross-sectional coordinates, lengths between two neighboring cross sections, and widths of the movable bed;
2. Sediment data: inflowing sediment load, gradation of bed material, and physical properties of sediment;
3. Hydraulic properties: includes those of Manning's roughness coefficient, water temperature, physical properties of fluid, and expansion or contraction coefficients;
4. Hydrologic data: inflow discharges and durations, and downstream stages; and
5. Operating rule: a relationship between discharge and water surface elevation at control sections of the study reach.

Application of the HEC-6 Model to Panther Slough

Geometric Data

The cross-sectional data were obtained from field trips conducted on November 16, 1994, and July 11, 1995. Five cross sections were surveyed and used to describe the study reach in the HEC-6 model. Their locations are shown in figure 4. The cross section farthest downstream is located at the mouth of Panther Slough where it enters the Illinois River, and the uppermost cross section is near the junction of Panther Slough and Chain Lake. Each cross section is divided into three strips representing the main channel and the left and right overbanks. The width of the main channel, i.e., the width of the movable bed, is considered to be 70 ft (21.3 m), and the total width of each cross section is 100 ft (30.5 m) from bank crest to bank crest on the basis of the field data. The elevation of left and right overbanks is 435 ft above MSL, and the bottom elevations of the channel vary from 424 ft to 426 ft. Panther Slough is 2,970 ft (914.4 m) long, and the cross sections are located at the entrance, the outlet, the bend, and in the middle of two straight reaches.

Manning's Roughness Coefficient

Based on field observations and the types of bed material in Panther Slough, the Manning coefficient n is estimated as 0.025. Applying this coefficient and considering the mean velocity and mean hydraulic radius in Panther Slough to be 1.7 ft/s (0.52 m/s) and 4.17 ft (1.27 m), respectively, on the basis of measurements from the November 16, 1994, field trip, the energy slope S for Panther Slough is calculated at approximately 0.00011 for that day. This value is very close to the surface slope calculated using field data.

Sediment Data

Bed Material Gradation. Bed material gradation is determined using information provided in table 10. As can be seen in this table, the bed material in Panther Slough and Chain Lake consists mainly of silt and clay with some percentage of fine sand, ranging from a low of 5 percent at locations #2B and #3B to a high of 25 percent at location #1B.

The percentages of sand, silt, and clay in the suspended sediment in the Chain Lake area are similar to those in the bed material. Similar percentages in suspended sediment and bed material were also found at Kampsville on the Illinois River. Therefore, 5 percent sand, 41 percent silt, and 54 percent clay are the ratios used in the HEC-6 model.

Inflow Sediment Load. Sediments are transported in water as either suspended load or bed load. Their sum is the total load that must be specified for the Panther Slough HEC-6 model. Measuring bed load is very difficult and inaccurate, thus an acceptable method for determining the bed load is increasing the suspended load by a certain percentage. Suspended load is determined from suspended sediment concentration. Suspended sediment concentrations were collected during the field trips at the sampling locations shown in figure 4. Results from the suspended sediment analyses are summarized in table 9.

The suspended sediment load transported in a channel can be determined by multiplying the water discharge by the sediment concentration. The INHS provided the water depth and flow speed at two locations near the junction of Panther Slough with Chain Lake, and these data were used to calculate the water discharges to Panther Slough. However, the INHS did not collect suspended sediment concentration data. In order to determine the inflow sediment load, information from a project on erosion and sedimentation in the Illinois River basin (Demissie et al., 1992) was used. This project developed relationships between water discharge and suspended sediment load for many streams in the Illinois River basin.

The procedure for determining the relationship between water discharge and sediment load consists of three steps:

1. Calculate the relationship between water discharge and sediment load using a generalized equation as (Demissie et al., 1992):

$$\log Q_s = A + B * (\log Q_w)^C \quad (19)$$

where Q_s is the sediment load in tons per day, Q_w is the water discharge in cfs, and A , B , and C are coefficients. For the Sangamon River near the Sanganois Area, $A = -0.6$, $B = 0.38$, and $C = 1.8$. Using equation (19) and the water discharge data obtained from the INHS, one can calculate the suspended sediment load from September 1989 to April 1993. However, the coefficients A , B , and C may not represent the values for Chain Lake.

2. Using the information on the suspended sediment load and the known water discharge data, calculate the sediment concentration using the following equation:

$$C_s = Q_s / (kQ_w) \quad (20)$$

where C_s is the suspended sediment concentration in mg/l and $k = 0.0027$.

3. Using field data ($Q_s = 498$ cfs and $C_s = 177.49$ mg/l) collected in the November 16, 1994, field trip, develop a new equation on the basis of equation (19) by changing coefficients A , B , or C and repeating Steps 1 and 2 so that the value of C_s computed from Equation (20) gradually approaches the measured value of 177.49 mg/l. Finally, a new equation describing the relationship between Q_s and Q_w for Chain Lake is obtained:

$$\log Q_s = -0.60 + 0.50 * (\log Q_w)^{1.8} \quad (21)$$

Equation (21) was further verified using the data collected in the July 11, 1995, field trip. First, using a measured water discharge, Q_w , of 721 cfs, the sediment discharge, Q_s , was obtained from equation (21). Second, equation (20) was used to calculate the suspended sediment concentration C_s . The calculated C_s of 264 mg/l is very close to the average measured C_s of 280 mg/l (table 9). Thus, given the known water discharge data, equation (21) can be used to calculate the suspended sediment loads into Panther Slough.

To estimate the total sediment load, the suspended sediment load is generally increased by 5 to 25 percent to account for the contribution of the bed load to the total load (Simons and Senturk, 1977). In this study, the bed load is assumed to be 5 percent of the total load.

Finally, the Panther Slough HEC-6 model used Tofaletti's relationship (1969) with Colby's correction (USACOE, 1977) for fine sediment provided by the new version of the HEC-6 model to determine transport capacity.

Hydrologic Data

Hydrologic data are input to the HEC-6 model by specifying inflow discharges and their durations. The monthly inflow discharges without control structures in place have been established (table 9). With structures in place, flows to Panther Slough will be halted in summer and fall when the gates are closed. However, they will be released when stages in Chain Lake exceed 429 to 430 ft in the summer and 432 to 433 ft in the fall. Such inflow discharges for summer and fall can be calculated using equation (17). This inflow hydrograph is the upstream boundary condition for the model. A detailed description of the inflow hydrograph with the structure in place will be given in a following section.

Downstream Boundary Conditions

Illinois River stages at RM 98.8 are used as the downstream boundary conditions where monthly mean stages have been estimated (table 2). However, the downstream stages can also fluctuate from these average values. To give a perspective on those situations, the historical data were analyzed to identify the range (maximum, minimum, and mean) of stage variations in each month. This information is presented in table 15.

Table 15. Ranges of Pool Elevations (in ft) in La Grange L & D

<i>Elevation</i>	<i>Jan</i>	<i>Feb</i>	<i>Mar</i>	<i>Apr</i>	<i>May</i>	<i>Jun</i>	<i>Jul</i>	<i>Aug</i>	<i>Sep</i>	<i>Oct</i>	<i>Nov</i>	<i>Dec</i>
Max.	440.5	440.4	446.6	445.5	447.2	445.1	445.9	445.1	440.8	440.3	444.1	445.6
Min.	420.1	426.4	426.4	426.6	426.6	426.7	426.1	426.3	426.9	425.2	426.8	426.9
Mean	431.6	432.1	433.6	434.7	434.3	432.6	431.6	430.5	430.4	430.6	430.9	431.4

Model Calibration

The model needs to be calibrated to make sure it reflects actual conditions. Generally this is done by comparing the measured and computed hydraulic parameters. Input data for the HEC-6 model were based on measurements from November 16, 1994,

and data measured on July 11, 1995, were used to calibrate the HEC-6 model. Table 16 shows a good relationship between the measured and calculated water surface elevation and flow velocity at given cross sections. Flows downstream of the old structure are complex, representing expansion from the constriction of the structure. Field data from July 1995 also showed that the velocity in the center was higher than it was near both banks. Since HEC-6 is a one-dimensional model, such distribution cannot be well represented.

Table 16. Comparisons of Model Results with Measured Data

<i>Cross section</i>	<i>Water surface elevation (ft)</i>		<i>Flow velocity (ft/s)</i>	
	<i>Calculated</i>	<i>Measured</i>	<i>Calculated</i>	<i>Measured</i>
CS1	432.22	432.10	1.72	2.25
CS2	432.09	N/A	2.12	2.27
CS3	431.96	N/A	2.03	2.08
CS4	431.81	N/A	2.15	2.62
CS5	431.70	431.70	1.90	1.98

Model Results and Discussion

The HEC-6 model has been applied to investigate the possible flow and sedimentation patterns in Panther Slough if a control structure is installed at its upstream section. The investigation includes input hydrographs representing low and high discharges both with and without the structure. Results can be interpolated for nonflooding conditions. When flood stage exceeds 435 ft, the model is not applicable because the whole area is inundated, and the main flow direction may not follow the direction of the channel in Panther Slough.

In the following discussion, two parameters are considered: 1) Discharge for both uncontrolled months (January to May) and controlled months (June to December); and 2) sedimentation (erosion or deposition) under given hydrologic conditions.

Impacts to Discharge and Stage

The purpose of using larger diameter pipes is to minimize possible changes in discharge and stages in Panther Slough so as to protect natural habitats, especially during the spring season when the gates are left open. How the culverts will affect flow and stages in Panther Slough can be observed by examining the hydrograph input to the HEC-6 model. Following are the specific boundary conditions used: average monthly inflows (table 4) and average monthly stages (table 5). While there are other possible inflow and downstream conditions, it is not feasible to investigate all of them.

The natural monthly inflow discharges (INHS data) are shown in table 17.

Table 17. Inflow Discharge (in cfs) without Structure - Flow Data Set 1

<i>Jan</i>	<i>Feb</i>	<i>Mar</i>	<i>Apr</i>	<i>May</i>	<i>Jun</i>	<i>Jul</i>	<i>Aug</i>	<i>Sept</i>	<i>Oct</i>	<i>Nov</i>	<i>Dec</i>
433	630	1,080*	946	1,009	686	628	430	598	267	420	984

*Note: Revised from original calculated discharge.

Discharge for March was reduced because the original calculated discharge (1,447 cfs) represents a flow above the bank stage, which cannot be used for conditions with the structure. The revised value represents the maximum discharge possible (calculated by Manning's formula) without overtopping the banks.

Once the structure is in place, its maximum capacity with all gates open is 1,050 cfs. Therefore, most flow between January and May can pass through culverts, although the peak stage may be smoothed. When inflow becomes larger, it overtops the structure and some flows still run through the culverts without much effect. However, impacts may become apparent from June to December when the gates are closed for lake management. During this period, flows need to be retained to build up the lake level. Once the lake level exceeds the design stages, excessive flows have to be drained. Drainage through culverts can be done when downstream stages are lower than upstream stages; otherwise, other means such as pumping are needed. Discharge through culverts can be calculated by equation (17) for two discharge scenarios.

June to August. The gates are closed to maintain a lake level between 429 and 430 ft above MSL and to minimize fluctuations in lake levels caused by stages of the Illinois River. When the desirable lake level is reached, an equal amount of inflows needs to be pumped out or drained out through culverts. Because the amount of inflow is relatively large and low lake levels have to be maintained, pumping or drainage must be done constantly. Hence, it is reasonable to assume the same natural monthly flow to Panther Slough for these three months.

September to December. The lake level is raised to between 432 and 433 ft above MSL. In order to meet this level requirement and to balance the inflow/outflow, the gates have to be operated. The modified discharge hydrograph is then specified for the model. Possible operations are demonstrated in the following scenario.

At the beginning of September, the water level is assumed to be 430 ft above MSL and the inflow is 598 cfs. Since the lake area is approximately 7.4 square miles, the additional water needed to raise the lake level to 433 ft above MSL is equal to $7.4 \times 5,280^2 \times 3 \text{ ft}^3$. With the given flow rate, such a lake level could be reached within approximately nine days (volume divided by $598 \times 86,400$). Within this period, there is no inflow to Panther Slough, and the water level in the Slough is equal to that of the Illinois River. After the ninth day, lake levels will exceed the desirable stage, and the gates will be opened to release water. The average tailwater level in September is around 430.7 ft; therefore, the culverts can drain flow at their design discharge of 1,050 cfs. The gates will be closed again once the lake level drops to 432 ft. The number of days needed to drop the water level to 432 ft can be computed by dividing the calculated volume (area times depth) by the net outflow — design discharge (1,050 cfs) minus inflow (598 cfs) — approximately 5.5 days. Once levels have dropped to 432 ft, lake management will close the gates again to raise the lake level to 433 ft, with an inflow rate of 598 cfs. The time needed to do this is approximately four

days. The operation then repeats this cycle. Outflows from the structure become stepwise-shaped with negligible discharge for nine days, increase to 1,050 cfs for 5.5 days, then again are reduced to minimum levels for four days. Operating conditions can be calculated similarly for October and November. In December the tailwater stage is high, and the entire flow has to be pumped out following the same procedures.

The inflow conditions reflect changes caused by the structure. A final remark relates to inflow in January. At the beginning of January, the gates are open with a head elevation of 433 ft and an average tail elevation of approximately 432 ft. Hence, the culverts can have an initial flow of 754 cfs, assuming the river is not frozen. This discharge will last for three days before the flow is equal to an average outflow of 433 cfs.

The projected monthly inflow discharge to Panther Slough after the structure is installed is given in table 18. Even though the information was developed on the basis of idealized conditions, it can demonstrate how the inflow hydrograph changes after installation of the structure. More importantly, this analysis gives a basis for assessing the impact to sedimentation in Panther Slough. Note that where discharge in the table is accompanied by a value in parentheses, the operation cycle is repeated during the month as discussed above. The value in parentheses represents the number of days the discharge will remain at that level.

Table 18. Inflow Discharge (in cfs) with Structure - Flow Data Set 2

<i>Jan</i>	<i>Feb</i>	<i>Mar</i>	<i>Apr</i>	<i>May</i>	<i>Jun</i>	<i>Jul</i>	<i>Aug</i>	<i>Sept</i>	<i>Oct</i>	<i>Nov</i>	<i>Dec</i>
754 (3)	630	1,080	946	1,009	686	628	430	0 (9)	1,050 (5)	1,050(4)	984
433(23)								1,050(5.5)	0(10)	0(6)	
								0 (4.5)			

Note: Values in parentheses represent days.

Another set of inflow conditions developed earlier for Panther Slough is discharge during nonflooding conditions. For the model test, this data set represents low discharge conditions. Sedimentation in Panther Slough under low discharge conditions needs to be

examined as well. Monthly discharges during nonflooding conditions were discussed in the section titled *Determination of Discharges from Chain Lake to Panther Slough*. Because the two methods used have produced similar results, only the INHS data are presented here (table 19).

Table 19. Inflow Discharge (in cfs) during Nonflooding Conditions without Structure - Flow Data Set 3

<i>Jan</i>	<i>Feb</i>	<i>Mar</i>	<i>Apr</i>	<i>May</i>	<i>Jun</i>	<i>Jul</i>	<i>Aug</i>	<i>Sept</i>	<i>Oct</i>	<i>Nov</i>	<i>Dec</i>
433	566	646	589	532	559	466	430	257	267	420	520

Similarly, inflows from June to January, after installation of a structure, can be recalculated using the previous argument. Monthly discharges during nonflooding conditions with the structure are described in table 20.

Table 20. Inflow Discharge (in cfs) during Nonflooding Conditions with Structure - Flow Data Set 4

<i>Jan</i>	<i>Feb</i>	<i>Mar</i>	<i>Apr</i>	<i>May</i>	<i>Jun</i>	<i>Jul</i>	<i>Aug</i>	<i>Sept</i>	<i>Oct</i>	<i>Nov</i>	<i>Dec</i>
754 (3)	566	646	589	532	559	466	430	0(18)	1,050 (5)	1,050(4)	886(6)
433(28)								1,050 (3)	0(10)	0(6)	0(4)
								0 (9)			

Note: Values in parentheses represent days.

Given the selected culvert dimensions, one can observe that the impacts to discharges are not significant in the period from January to August, but are significant from September to December. During this latter period, the discharges appear to be stepwise-shaped, and whenever there is a discharge, it is likely to be the maximum discharge.

Sedimentation Patterns in Panther Slough

Sedimentation patterns in Panther Slough were investigated using the inflow conditions (Data Sets 1 through 4, tables 17-20) described above. The HEC-6 model gives bed changes at each cross section at each time step. These bed changes are relative to the thalweg elevations at the beginning of the model run. Tables 21 and 22 list the changes in bed elevation for each time step discussed earlier. Note that these results are derived from input hydrographs that are based on ideal conditions.

Table 21. Comparison of Bed Changes (in ft) with and without Structure Using Flow Data Sets 1 and 2

<i>Month</i>	<i>Without structure</i>					<i>With structure</i>				
	<i>CS 1</i>	<i>CS 2</i>	<i>CS 3</i>	<i>CS 4</i>	<i>CS 5</i>	<i>CS 1</i>	<i>CS 2</i>	<i>CS 3</i>	<i>CS 4</i>	<i>CS 5</i>
January	0.01	0.00	0.00	0.00	0.00	-0.03	-0.01	0.00	-0.01	0.01
	0.09	0.02	0.02	0.00	0.02	0.06	0.02	0.01	-0.01	0.02
February	-0.01	0.00	0.01	0.00	0.06	-0.01	0.00	0.01	0.00	0.05
March	-0.11	-0.03	0.02	0.02	0.02	-0.07	0.02	0.02	0.02	0.01
April	0.02	-0.01	0.00	0.01	0.06	0.05	0.00	0.01	0.01	0.07
May	-0.10	-0.03	-0.01	-0.01	0.02	-0.06	-0.02	-0.01	-0.01	0.02
June	-0.13	-0.04	-0.04	-0.03	-0.01	-0.10	-0.04	-0.04	-0.03	-0.01
July	-0.18	-0.09	-0.04	-0.09	0.00	-0.16	-0.09	-0.06	-0.08	0.01
August	-0.20	-0.09	-0.08	-0.09	-0.05	-0.17	-0.09	-0.07	-0.09	-0.06
September	-0.31	-0.11	-0.09	-0.12	-0.07	-0.17	-0.09	-0.07	-0.09	-0.06
	-0.35	-0.12	-0.10	-0.13	-0.11	-0.20	-0.14	-0.11	-0.13	-0.06
October	-0.39	-0.13	-0.11	-0.14	-0.11	-0.20	-0.14	-0.11	-0.13	-0.06
	-0.43	-0.14	-0.12	-0.15	-0.13	-0.30	-0.17	-0.11	-0.14	-0.13
	-0.46	-0.15	-0.13	-0.16	-0.13	-0.30	-0.17	-0.11	-0.14	-0.13
	-0.43	-0.14	-0.12	-0.15	-0.12	-0.43	-0.20	-0.12	-0.20	-0.18
	-0.36	-0.11	-0.10	-0.14	-0.11	-0.43	-0.20	-0.12	-0.20	-0.18
	-0.33	-0.10	-0.09	-0.13	-0.10	-0.46	-0.23	-0.17	-0.24	-0.23
November	-0.25	-0.06	-0.06	-0.11	-0.08	-0.45	-0.22	-0.17	-0.24	-0.23
	-0.25	-0.06	-0.06	-0.11	-0.07	-0.48	-0.24	-0.19	-0.26	-0.24
	-0.24	-0.06	-0.06	-0.11	-0.06	-0.48	-0.24	-0.19	-0.26	-0.24
	-0.24	-0.06	-0.05	-0.11	-0.06	-0.55	-0.25	-0.21	-0.28	-0.24
December	-0.24	-0.06	-0.05	-0.10	-0.06	-0.55	-0.25	-0.21	-0.28	-0.24
	-0.24	-0.06	-0.05	-0.10	-0.05	-0.62	-0.26	-0.22	-0.28	-0.25
	-0.23	-0.06	-0.05	-0.10	-0.05	-6.62	-0.26	-0.22	-0.28	-0.25
	-0.48	-0.08	-0.08	-0.11	-0.10	-0.61	-0.26	-0.20	-0.29	-0.26

The feasibility of using released flow from culverts to flush out newly deposited sediment can be observed from rows 2 and 4 for September in table 21 or during other months when gates are in operation. In September, the average natural inflow is relatively high; thus the channel is subjected to erosion even without the structure in place. With the structure in place, a clear scouring pattern develops over the whole channel after the gates are opened (the difference between rows 1 and 2 for September output in table 21). The advantage of having controlled flow becomes more obvious in October, when the natural inflow is relatively low. Without the structure, deposition occurs over the channel (difference in depth between rows 3 and 2 for October output in table 21), while with the structure, scouring occurs with release of flow. The model results demonstrate the feasibility of developing a nearly uniform scouring for the channel with the maximum discharge developed by culvert control.

Sedimentation patterns given lower discharges are shown in table 22.

Table 22. Comparison of Bed Changes (in ft) with and without Structure Using Flow Data Sets 3 and 4

<i>Month</i>	<i>Without structure</i>					<i>With structure</i>				
	<i>CS 1</i>	<i>CS 2</i>	<i>CS 3</i>	<i>CS 4</i>	<i>CS 5</i>	<i>CS 1</i>	<i>CS 2</i>	<i>CS 3</i>	<i>CS 4</i>	<i>CS 5</i>
January	0.01	0.00	0.00	0.00	0.00	-0.03	-0.01	0.00	-0.01	0.01
	0.09	0.02	0.02	0.00	0.02	0.06	0.02	0.01	-0.01	0.02
February	0.08	0.01	0.04	0.02	0.07	0.07	0.01	0.03	0.01	0.06
March	0.48	0.06	0.05	0.23	0.06	0.48	0.06	0.05	0.23	0.05
April	1.09	0.30	0.25	0.41	0.21	1.09	0.30	0.25	0.41	0.21
May	1.63	0.55	0.45	0.59	0.36	1.63	0.55	0.45	0.58	0.35
June	0.66	0.63	0.65	0.66	0.50	0.69	0.62	0.65	0.66	0.49
July	0.73	0.45	0.41	0.59	0.47	0.74	0.45	0.41	0.59	0.47
August	0.59	0.43	0.37	0.49	0.33	0.66	0.42	0.36	0.49	0.32
September	0.71	0.48	0.37	0.53	0.32	0.67	0.42	0.36	0.49	0.32
	0.73	0.48	0.37	0.54	0.32	0.54	0.40	0.35	0.43	0.21
	0.78	0.48	0.37	0.57	0.31	0.54	0.40	0.35	0.43	0.21
October	0.81	0.50	0.37	0.58	0.31	0.35	0.37	0.31	0.38	0.20
	0.87	0.53	0.37	0.61	0.31	0.36	0.37	0.32	0.38	0.20
	0.89	0.53	0.37	0.62	0.31	0.23	0.33	0.28	0.37	0.14
	0.94	0.54	0.37	0.65	0.30	0.23	0.33	0.28	0.37	0.14
November	0.91	0.54	0.39	0.65	0.30	0.15	0.31	0.26	0.35	0.09
	0.88	0.54	0.39	0.65	0.30	0.15	0.31	0.26	0.35	0.09
	0.87	0.53	0.39	0.65	0.31	0.09	0.29	0.24	0.31	0.08
	0.87	0.53	0.39	0.65	0.31	0.09	0.29	0.24	0.31	0.08
	0.86	0.53	0.39	0.65	0.31	0.04	0.27	0.22	0.27	0.07
December	0.86	0.53	0.38	0.65	0.31	0.04	0.27	0.22	0.27	0.07
	0.87	0.53	0.38	0.65	0.30	0.04	0.25	0.21	0.26	0.06
	0.87	0.53	0.38	0.65	0.29	0.04	0.25	0.21	0.26	0.06
	0.87	0.53	0.38	0.65	0.29	0.04	0.24	0.20	0.25	0.04
	0.87	0.53	0.38	0.65	0.29	0.04	0.24	0.20	0.25	0.04
	0.87	0.53	0.38	0.65	0.29	0.04	0.23	0.19	0.24	0.03
	0.87	0.53	0.38	0.65	0.29	0.05	0.23	0.19	0.24	0.03

It becomes apparent that deposition will develop under these low discharge conditions. The advantage of using flushing flows in reducing the siltation can be observed by comparing results at the end of December.

Although it is conceivable that discharge (or velocity) is the controlling factor for erosion or deposition in Panther Slough, it should be recognized that the river stage at the mouth of the Slough can also greatly affect sedimentation. The effects of stages and discharges are shown in tables 21 and 22 and illustrated in figure 11.

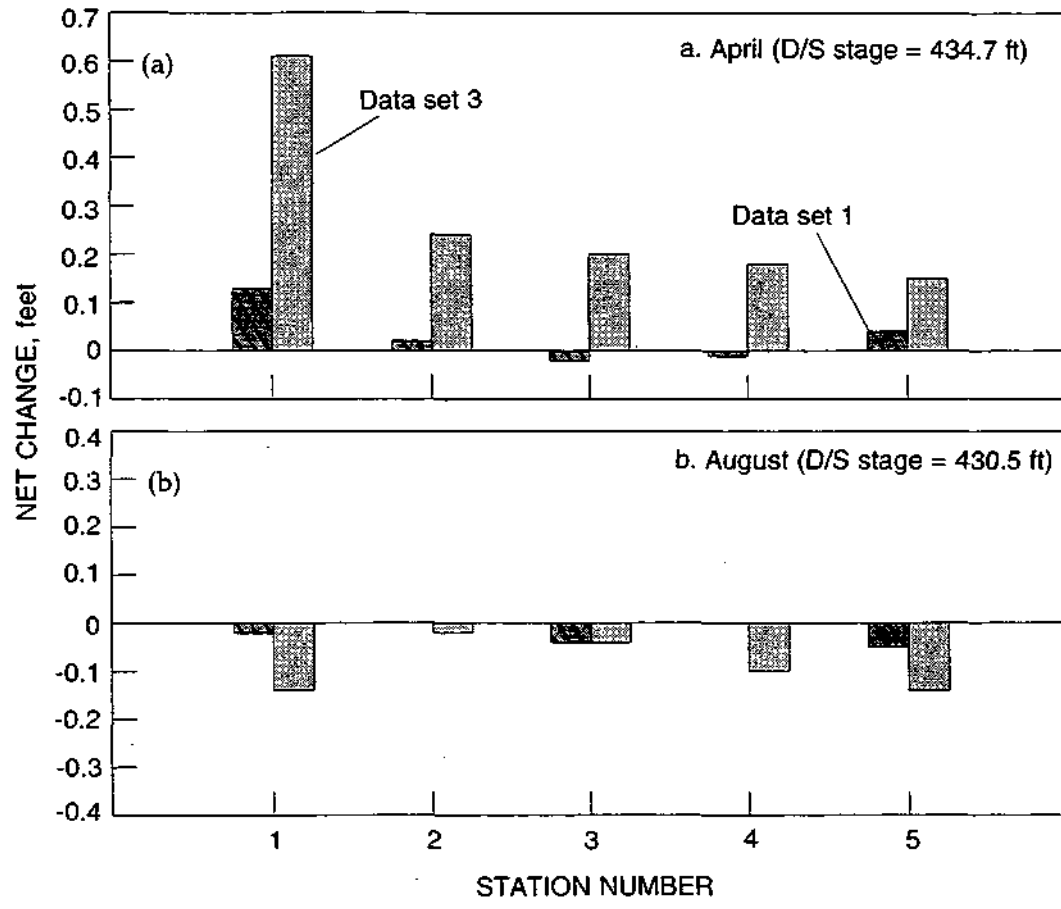

Figure 11. Effect of downstream stages on sedimentation patterns in April (a) and August (b)

Figure 11a shows the net bed change between April and March (high downstream stage) and figure 11b shows the net bed change between August and July (low downstream stage). Note that discharge in April is higher than that in August. Results in both figures are based on conditions without a structure in place (conditions with the structure produce similar results before September). After April, Data Set 3 (lower input discharge, table 19) produced higher deposition than Data Set 1 (higher discharge, table 17). Overall, despite the fact that April has a higher discharge than August, deposition occurred in April and erosion occurred in August because of differences in downstream stages.

Figure 12 shows the long-term effects of high and low discharges on bed changes with (12b) and without (12a) the control structure in place. It can be observed that low discharges cause deposition and high discharges cause erosion. With the structure in place and with flushing floods (12b), bed changes are minimal for low discharges, but erosion occurs for higher discharges. The patterns are rather uniform for the whole channel, which is advantageous since some deposition will occur during floods or slacking flows.

Figures 13a and b illustrate the effects of low discharges and high discharges, respectively, on bed changes with and without the structure in place. The advantage of the structure in reducing siltation is demonstrated in both cases.

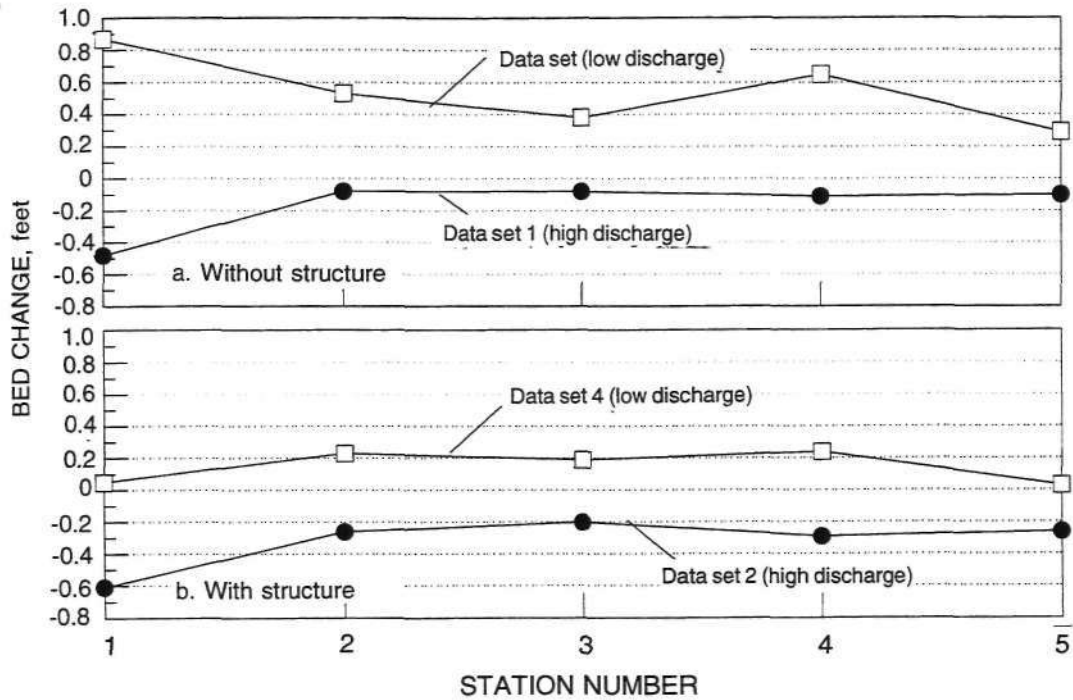

Figure 12. Effects of high and low discharges on bed changes without the control structure (a) and with the structure (b)

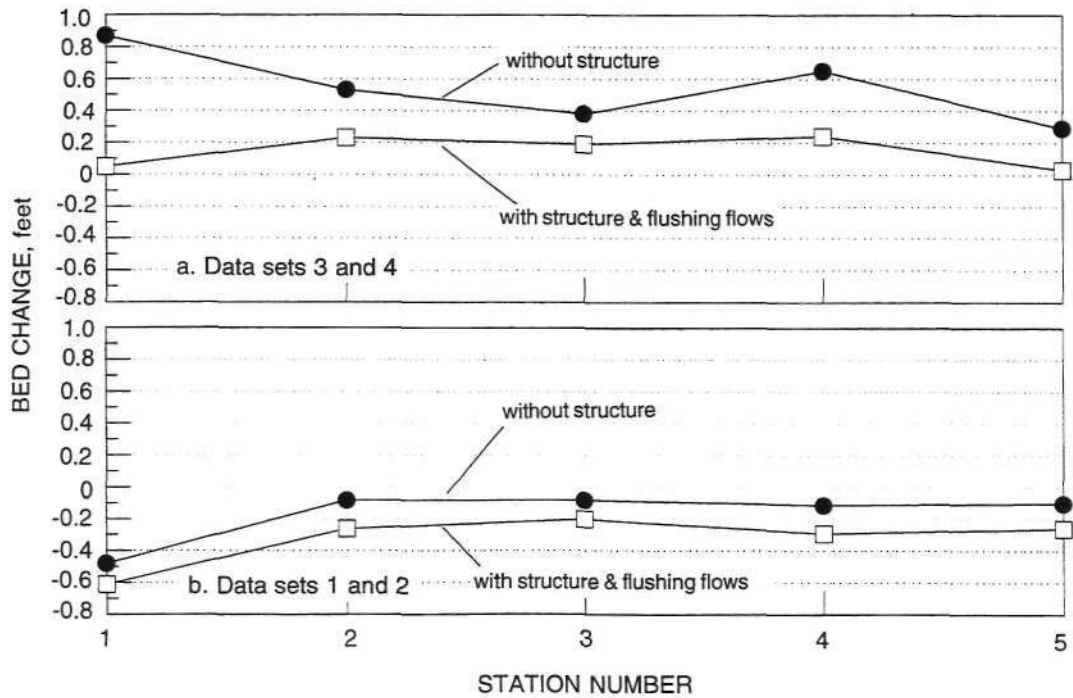

Figure 13. Effects of low discharges (a) and high discharges (b) on bed changes, both with and without the structure

SUMMARY

This report summarizes an investigation of the hydraulics and sediment transport in Panther Slough in the Sanganois Conservation Area, Mason County, Illinois. The purpose of this joint project between the Illinois State Water Survey and Illinois Department of Conservation (IDOC) is to investigate sedimentation conditions in Panther Slough if a control structure is built at the junction with Chain Lake. The IDOC will operate this structure for water level management in Chain Lake from June to December of each year. The operational criteria for the control structure are:

1. to maintain Chain Lake water levels at 429 to 430 ft above mean sea level (MSL) in the summer and 432 to 433 ft MSL in the fall;
2. to keep minor Illinois River fluctuations from raising or lowering water levels in Chain Lake from June to December of each year; and
3. to prevent siltation in Panther Slough.

The goal of this study is to determine what type of structure can be used and how it will affect sedimentation in Panther Slough.

The entire study area is in a low-lying area near the Illinois River, and stage fluctuations in the river are felt profoundly. Since not much data were available, the authors assessed the hydrologic conditions in the Chain Lake/Panther Slough area and collected field data on three occasions for the determination of regional hydraulics and sediment characteristics. They found that the major source of flow and sediment to Chain Lake (and hence Panther Slough) is from the East Branch of the Illinois River. The Illinois River has high sediment concentrations during spring floods. However, most coarser particles are deposited at the mouth of Snicarte Slough when entering West Stewart Lake. Remaining fine materials are transported to Chain Lake and Panther Slough. Nonetheless, it was found that sediment concentrations in Panther Slough are still comparable to those of the Illinois River.

The maximum discharge from Chain Lake to Panther Slough was determined to be 1,050 cfs (30 cms) by two different methods. Given the high sediment concentration and probabilities of flooding, it is postulated that sedimentation will occur in the Slough when

the structure is in place and closed for lake management, and when flows in the Slough are low. A brief examination of critical tractive force for the fine materials present in this area shows that higher flow conditions have the capacity to carry sediment out of the Slough. It was assumed that a culvert with control gates that can use the available discharge to flush out newly deposited sediment will be used. Using the maximum discharge as the design discharge, the authors applied an HY8 program to test culvert design. Recommendation is given to a structure consisting of three barrels of conventional circular concrete, each with a diameter of 6.5 ft (1.98 m).

In order to investigate the possible sedimentation patterns in Panther Slough once the structure is installed, the authors developed an HEC-6 model for the Slough. This model was furnished with data collected by the authors and calibrated by actual field data. This report gives a brief description of the model's capacities and limitations.

Although the one-dimensional sediment transport model is deficient in terms of simulating reverse flow or more complicated flow conditions, it gives a very good representation of what can happen in Panther Slough with the structure in place. The calibration showed that the HEC-6 model reproduced field hydraulic parameters very well. Upstream near the old structure, flow is complex and may somewhat violate the one-dimensional limitation of the HEC-6 model. From among the wide range of possible inflow and downstream boundary conditions, the authors used one set of high discharge data and one set of low discharge data as input to the Slough model, and used the monthly average stage of the Illinois River at RM 98.8 as the downstream conditions. Both high and low discharges were run for a one-year period with and without the structure.

Examination of model results indicates that:

- Deposition will occur if discharge is low.
- Downstream stages can greatly affect erosion and deposition patterns in the Slough.
- With the structure in place, lake-level managers still need to operate the gate or use the pump between June and December. Significant impact to discharge

patterns will occur between September and December, and fewer impacts will occur in other months.

- The operation of gates provides an opportunity to develop "flushing flows" for Panther Slough. Given the head developed in the lake and the downstream elevation of the Illinois River, the release of flow has proven to be beneficial in flushing out newly deposited sediment. The results demonstrated that deposition was reduced at low discharges with the flushing floods. Also the bed changes were more uniform over the channel reach.

In addition to low and high inflows, flood inundation is another major cause of sedimentation for the area. An estimated deposition rate of 0.3 inches/year was derived by analogizing the annual sedimentation rate in backwater lakes along the Illinois River. Sedimentation caused by floods was not considered by the model. On the other hand, the model revealed that, under current conditions, Panther Slough will be subjected to deposition during low inflows and erosion during high inflows. Sedimentation is affected by stages of the Illinois River. If the downstream stages are high, deposition occurs even if the inflow is high. The authors tested an idealized flushing flow operation that can be developed after the structure is installed. The results demonstrated that the flushing flow can be used advantageously to flush out newly deposited sediment in the Slough under various inflow and downstream stage combinations.

REFERENCES

- Buchanan, T.J. and W.P. Somers. 1969. Discharge Measurements at Gaging Stations. In *Techniques of Water-Resources Investigations of the United States Geological Survey*. Chapter A8, Book 3, Applications of Hydraulics.
- Chow, V.T. 1969. *Open Channel Hydraulics*. McGraw Hill Books.
- Demissie, M., L. Keefer, and R. Xia. 1992. *Erosion and Sedimentation in the Illinois River Basin*. ILENR/Re-WR-92104.
- Dunn, I.S. 1959. Tractive Resistance of Cohesive Channels. *Journal of Soil Mechanics and Foundation Division*, Proc. ASCE, No. SM-3.
- Egiazaroff, I.V. 1965. Calculation of Nonuniform Sediment Concentration. *Journal of Hydraulic Division*, Proc. ASCE, Vol. 91, No. HY-4.
- Fan, S.S., ed. 1988. *Twelve Selected Computer Stream Sedimentation Models Developed in the United States*. Interagency Ad Hoc Sedimentation Work Group. Published by Federal Energy Regulatory Commission.
- Iwagaki, Y. 1956. *Hydrodynamical Study on Critical Tractive Force*. Trans. JSCE, No. 41, 1956, (In Japanese).
- Lee, M.T. 1982. *Sediment Conditions in the Sanganois Conservation Area, Cass and Mason Counties, Illinois*. Illinois State Water Survey Contract Report 290. Champaign.
- Mavis, F.T. 1943. *The Hydraulics of Culverts*. Pennsylvania Engineering Experiment Station Bulletin 56.
- Roberts, W. and J.B. Stall. 1967. *Lake Evaporation in Illinois*. Illinois State Water Survey Report of Investigation 57. Champaign.
- Schwab, G.O., Frevert, R.K., Edminister, T.W. and K.K. Barnes. 1981. *Soil and Water Conservation Engineering*. 3rd Edition. John Willey and Sons. New York.
- Shields, A. 1936. *Anwendung der Aehnlichkeitsmechanik und der Turbulenzforschung auf die Geschiebebewegung*. Mitteilungen der Pruessischen Versuchsanstalt fur Wasserbau und Schiffbau. Berlin.
- Simons, D.B. and F. Senturk. 1977. *Sediment Transport Technology*. Water Resources Publications. Fort Collins, CO.
- Tofaletti, F.B. 1969. *Definitive Computations of Sand Discharge in Rivers*. Journal of Hydraulic Division, Proc. ASCE, Vol. 95, No. HY-1.
- U.S. Army Corps of Engineers. 1977. *HEC-6 Scour and Deposition in Rivers and Reservoirs. Users Manual*. USACOE The Hydrologic Engineering Center. 609 Second Street, Davis, CA 95616. 45p.

White, C.M. 1940. *The Equilibrium of Grains on the Bed of Stream*. Proc. RSL, Series-A, Mathematical and Physical Sciences, No. 958, Vol. 174.

Yalin, M.S. and E. Karahan. 1979. Inception of Sediment Transport. Journal of Hydraulic Division, Proc. ASCE, Vol. 105, HY-11.

Appendix

**Estimated Sedimentation in Backwater Lakes
in the Illinois River Valley**

Appendix

Estimated Sedimentation in Backwater Lakes in the Illinois River Valley

<i>Pool</i>	<i>Lake name</i>	<i>River mile</i>	<i>Capacity (acre-feet)</i>			<i>Sedimentation rate(in/yr)</i>	<i>Capacity loss (percent)</i>
			<i>1903</i>	<i>1975</i>	<i>1990*</i>		
Alton	Swan Lake	5	4,816	2,783	2,359	0.18	51
	Lake Meredosia	72	7,791	4,207	3,460	0.43	56
La Grange	Muscooten Bay	89	1,459	184	0	3.12	100
	Patterson Bay	107	271	165	143	0.31	47
	Lake Chautauqua	125	14,293	11,679	11,134	0.33	22
	Rice Lake	133	3,064	1,119	714	0.32	77
	Pekin Lake	153	323	226	206	0.08	36
Peoria	Peoria Lake	162	120,000	56,600	29,150	0.79	76
	Babb's Slough	185	1,377	625	468	0.14	66
	Weis Lake	191	450	1,10	39	0.15	91
	Sawmill Lake	197	2,110	3,81	21	0.47	99
	Lake Senachwine	199	9,240	2,468	1,057	0.30	86
	Lake DePue	203	2,837	778	349	0.59	88
	Huse Flough	221	253	51	9	0.96	96
Marseilles	Ballard's Slough	248	142	36	14	0.91	90

