

WRC RESEARCH REPORT NO. 149

SURCHARGE OF SEWER SYSTEMS

Ben Chie Yen  
Nicholas Pansic  
Department of Civil Engineering  
University of Illinois at Urbana-Champaign

F I N A L R E P O R T

Project No. A-086-ILL

The work upon which this publication is based was supported by funds provided by the U. S. Department of the Interior as authorized under the Water Resources Research Act of 1964, P. L. 88-379 Agreement No. 14-31-0001-8015

UNIVERSITY OF ILLINOIS  
WATER RESOURCES CENTER  
2535 Hydrosystems Laboratory  
Urbana, Illinois 61801

March 1980

Contents of this publication do not necessarily reflect the views and policies of the Office of Water Research and Technology, U.S. Department of the Interior, nor does mention of trade names or commercial products constitute their endorsement or recommendation for use by the U.S. Government.

## ABSTRACT

### SURCHARGE OF SEWER SYSTEMS

Surcharge of a sewer is the situation in which the sewer entrance and exit are submerged and the pipe is flowing full and under pressure. In this report the hydraulics of the surcharged flow as well as the open-channel flow leading to and after surcharge is discussed in detail and formulated mathematically. The transition between open-channel and surcharge flows is also discussed. This information is especially useful for those who intend to make accurate advanced simulation of sewer flows. In this study an approximate kinematic wave - surcharge model called SURKNET is formulated to simulate open-channel and surcharge flow of storm runoff in a sewer system. An example application of the model on a hypothetical sewer system is presented.

Yen, Ben Chie, and Pansic, Nicholas

SURCHARGE OF SEWER SYSTEMS

Research Report No. 149, Water Resources Center, University of Illinois, Urbana, Illinois, March 1980, v+61 pp.

KEYWORDS--computer models/conduit flow/\*drainage systems/flood routing/hydraulics/hydrographs/mathematical models/ open-channel flow/\*sewers/sewer systems/\*storm drains/storm runoff/\*unsteady flow/urban drainage/urban runoff

# CONTENTS

	Page
LIST OF FIGURES . . . . .	iv
LIST OF TABLES . . . . .	v
CHAPTER	
I. INTRODUCTION . . . . .	1
II. RELATED PREVIOUS WORK . . . . .	5
2.1. Related Work on Pressurized Network Flow . . . . .	5
2.2. Related Work on Sewer Surcharge . . . . .	6
2.3. Other Related Previous Studies . . . . .	9
III. THEORY OF SEWER NETWORK HYDRAULICS . . . . .	13
3.1. Flow in a Sewer Pipe . . . . .	13
3.1.1. Classification of Flow in Single Pipe . . . . .	13
3.1.2. Hydraulic Behavior of Flow in Single Pipe . . . . .	18
3.1.3. Mathematical Representation of Flow in a Pipe . . . . .	22
3.2. Flow in a Sewer Network . . . . .	27
3.2.1. Sewer Junctions . . . . .	27
3.2.2. Sewer Networks . . . . .	32
IV. KINEMATIC WAVE - SURCHARGE MODEL . . . . .	37
4.1. Kinematic Wave Approximation . . . . .	37
4.2. Formulation of SURKNET Model . . . . .	39
4.2.1. Open-Channel Flow . . . . .	39
4.2.2. Surcharged Flow . . . . .	40
4.2.3. Flow Transition . . . . .	43
4.2.4. Boundary Conditions . . . . .	45
4.3. SURKNET Computer Program . . . . .	47
4.4. Example Application of SURKNET . . . . .	47
4.4.1. Example Sewer Network . . . . .	47
4.4.2. Results . . . . .	50
V. CONCLUDING REMARKS . . . . .	57
REFERENCES . . . . .	58

UI WRC Report 149

Errata

Page	Line	
iv	6 and 7	interchange captions of Figs. 3.1 and 3.2
16	bottom	interchange captions of Figs. 3.1 and 3.2
28	20	change "when z is the elevation of the junction bottom." to "where z is the elevation of the junction bottom,"
39	8	delete "a", should read "in finite difference".
40	12	change "section" to "sectional"
44	8	change "ration" to "ratio"
44	24	change "of a" to "of an"
45	7	change "connected to its upstream. For" to "connected at the upstream end. For the"
47	4	change " $A_2H_2 - A_1H_1 - \Delta s$ which is the change of water volume on the ground." to " $A_2H_2 - A_1H_1 = \Delta s$ which is the change in volume of water on the ground."
50	6	change "plots" to "plot"
50	9	change "purposely" to "purposedly"
58	13	change "p. 60," to "60 p."

## LIST OF FIGURES

Figure	Page
2.1    Preissmann Slot . . . . .	8
2.2    U.S. Geological Survey Culvert Flow Classification . . . . .	12
3.1    Sewer Exit Flow Cases . . . . .	16
3.2    Sewer Entrance Flow Cases . . . . .	16
3.3    Classification of Flow in a Sewer . . . . .	17
3.4    Roll Waves in a Sewer . . . . .	19
3.5    Discharge Rating Curve for Steady Flow in a Circular Pipe . . . . .	21
3.6    Air Entrainment Instability in a Sewer . . . . .	21
3.7    Open-Channel Flow in a Sewer . . . . .	23
3.8    Surcharged Flow in a Sewer . . . . .	26
3.9    Schematic Drawing of Sewer Junction . . . . .	29
3.10    Backwater Effect on Discharge of an Oakdale Avenue Sewer . . . . .	35
4.1    Example of Propagation of Flow Transition . . . . .	42
4.2    Flow Chart for Computer Program SURKNET . . . . .	48
4.3    Example Sewer Network . . . . .	51
4.4    Discharge and Storage Graphs for Element 1-3 . . . . .	52
4.5    Discharge and Storage Graphs for Element 2-3 . . . . .	53
4.6    Discharge and Storage Graphs for Element 3-5 . . . . .	54
4.7    Discharge and Storage Graphs for Element 4-5 . . . . .	55
4.8    Discharge and Storage Graphs for Element 5-6 . . . . .	56

LIST OF TABLES

TABLE		Page
3.1.	Pipe Entrance Conditions . . . . .	14
3.2.	Pipe Exit Conditions . . . . .	14
3.3.	Pipe Flow Conditions . . . . .	15
3.4.	Indentification of Bodhaine's Types of Pipe Flow . . . . .	18
4.1.	Sewer Properties of Example Network . . . . .	49
4.2.	Manhole Properties of Example Network . . . . .	49
4.3.	Example Manhole Inflow Hydrograph . . . . .	51

## I. INTRODUCTION

In the terminology of sewerage engineering, surcharge is defined as the condition that the sewer is flowing full and gravity-flow no longer prevails. In hydromechanics, this condition is commonly referred to as pressurized-conduit flow. Although sewers are traditionally designed assuming open-channel flow, i.e., gravity flow in sewerage terminology (ASCE, 1969), surcharge of sewers may well occur in both overloaded existing systems and in new system designs. Some of the reasons for sewer surcharge are as follows.

- (a) Underdesign resulting from inaccuracies in the design equations, coupled with uncertainty in design parameters (e.g., pipe roughness), can adversely affect system design.
- (b) Hydrologic risk may cause surcharge because there is always a probability, no matter how small, that the design discharge may be exceeded one or more times during the service life of the sewer.
- (c) Construction errors and material deviations (e.g., tolerance in the pipe dimensions), resulting in the sewer system in-place not conforming to the design.
- (d) In-line pumping stations that may be required due to system constraints.
- (e) In-line detention or retention storage resulting in submergence of connecting pipes.

- (f) Changing sewer system conditions after completion of construction, such as blocking of manholes, deposition and deformation of sewer pipes.
- (g) Change of drainage basin characteristics after the design and construction are completed.

A sewer system is characterized by a network of manholes and junctions (nodes) connected by sewer pipes (links), usually of the dendritic type although the loop-type networks are not uncommon. Storm sewer flow is time-varying (i.e., transient or unsteady) in nature because all rainstorms have finite durations and consequently the flood flow in the sewers changes with time. If the flood is small, none of the sewer pipes are completely filled and the flow remains as open-channel flow. However, for large floods, some or all of the sewer pipes may change from open-channel flow to pressurized-conduit flow during and near the time of the flood peak. Moreover, the flow in a sewer is affected by the hydraulic conditions at both its upstream and downstream ends. The rare exception is the case of supercritical gravity flow for which only the upstream effect is important (Yen, 1977; Sevuk and Yen, 1973). Hydrodynamically, the transition between open-channel flow and surcharged flow in a sewer system is one of the most complicated unsolved problems (Yen, 1978a).

In the management of sewer flow for pollution control and flood mitigation, reliable prediction of the sewer flow is important. Obviously, without an accurate evaluation of manhole surcharge, it is not possible to predict reliably the level of flooding due to storm runoff.



In recent years the abatement of storm runoff pollution is an important concern. In order to meet the requirements of the Water Pollution Control Act Amendments of 1972, P.L. 92-500, the construction of many new wastewater treatment plants and the modification of existing plants have been proposed or are underway in the United States. It is commonly acknowledged that large treatment plants of the size required to handle the peak storm runoff from urban areas are economically unjustifiable. Flow rate equilization through the use of upstream storage is desirable. Furthermore, treatment plants operate most efficiently when the flow is constant at the design flow rate. Use of on-site and/or in-line detention storage has been considered as an effective means of flow equilization. For urban sewer systems the sewers joining the in-line detention facilities are usually under surcharge, particularly during and immediately after a heavy rainstorm. If the surcharge flows cannot be reliably predicted, it is most unlikely that the purpose of flow equilization for urban runoff pollution abatement can be satisfactorily achieved.

Consider a sewer design permitting a limited degree of surcharge for a few sewers, with the water confined within manholes and junctions and not flooding the ground and pavement. Under certain circumstances, additional hydraulic head will be available from the difference of the water surfaces in the upstream and downstream manholes or junctions. The resulting higher flow velocity will allow the use of a smaller sewer than would be the case for gravity flow. If this surcharge condition occurs in the most expensive sewer pipes in the system, the savings in using smaller sewers can be considerable, achieving a more economical design for the sewer system. Conversely, if the surcharge is not properly simulated, the sewer may be oversized or undersized. In the former case it will be a waste of money

for the protection required, whereas for the latter case the undersized sewers will be unable to handle the design storm runoff, causing frequent flooding.

The objective of this research project is to develop an improved sewer surcharge simulation model which can be used to investigate the effects of surcharge on both sewer design and drainage operation. In this report, after a brief review of related previous work and hydraulic theory, a nonlinear kinematic wave sewer surcharge simulation scheme is described and an example is presented.

## II. RELATED PREVIOUS WORK

Many sewer flow simulation methods have been proposed in the past, ranging from the simple rational method (ASCE, 1969; Yen, 1978b) to the highly sophisticated computer-based Storm Water Management Model (SWMM, Metcalf & Eddy et al., 1971) and Illinois Storm Sewer System Simulation (ISS) Model (Sevuk et al., 1973). Most of the existing pipe network flow models are either purely open-channel flow or completely pressurized-conduit flow models. Readers are suggested to refer to published references (e.g., James F. MacLaren, 1975; Chow and Yen, 1976, Brandstetter, 1976; and Colyer and Pethick, 1976) for a review of the existing open-channel flow sewer simulation models.

### 2.1. Related Work on Pressurized Network Flow

The existing pressurized pipe network flow simulation models are primarily steady flow models developed for water-supply networks and not specifically for sewers. These models handle loop-type networks and usually solve the flow equations using one of three approaches: those following Cross' (1936) concept of successive relaxation applied to each loop (Adams, 1961; Dillingham, 1967; Graves and Branscome, 1958; Hoag and Weinberg, 1957; Jacoby and Twigg, 1968); those employing the Newton-Raphson method for successive relaxation of all loops simultaneously (Epp and Fowler, 1970; Martin and Peters, 1963; Lekane, 1979, Lemieux, 1972); and those using linearization (Marlow et al., 1966; Wood and Charles, 1972). Although it has been shown that the Darcy-Weisbach or Colebrook-White resistance formulas can be programmed for solution (Fietz, 1973; Lekane, 1979), most of these models use the less desirable Hazen-William's formula. This is partly because the latter is easier to solve, but

probably due more to the fact that Cross used the formula in his original development at the University of Illinois in 1936. Considering the wide range of the Reynolds number of the flow in storm sewers and the later development in fluid mechanics, the Hazen-William formula is not a preferred resistance formula to be used. A review of the steady flow network models can be found in Jeppson (1975) and Shamir (1973).

Of the existing pressurized pipe network transient flow models, the majority are "water hammer" models emphasizing pressure surges (Wylie and Streeter, 1978). The remaining few that handle unsteady flow in pressured pipe networks cannot be applied directly to surcharged sewer systems. However, they are clearly useful in formulating a surcharged unsteady flow sewer model. Stoner (1968), Wylie et al. (1974), and Vardy (1976) applied the method of characteristics to model the unsteady flow of gas in pipe networks.

## 2.2. Related Work on Sewer Surchage

Recently, approximate techniques for surcharge flow routing have been incorporated into a number of sewer flow simulation models. Models using only Manning's or Darcy-Weisbach's formulas for open-channel flow routing in sewers can approximate surcharged flow. This is done by using the full pipe diameter and hydraulic radius in the computations, but it must include a means to estimate the available head for the flow. Examples of such models are TRRL (1976) and ILLUDAS (Terstriep and Stall, 1974) for which the flow simulation proceeds pipe by pipe from the upstream to downstream end of the network in a cascading manner. Assumptions are made to estimate the piezometric heads at the upstream and downstream ends of a pipe with no direct interaction of the pressure and discharge between upstream and downstream pipes considered. In the Storm Water Management Model (SWMM, Metcalf & Eddy et al., 1971), whenever surcharge occurs, the excess water is

assumed to store in the upstream manhole without affecting the dynamics of the flow.

A method proposed by Shubinski and Roesner (1973) adopted Hardy Cross' (1936) method to estimate the flow (which was implicitly assumed steady within the computational time interval) in surcharged pipes. The water depths in the manholes are then readjusted based on the continuity principle before proceeding to the next time interval computation. They found this method unstable and later proposed a different version which is incorporated into SWMM as a part of the WRE Transport Block (EXTRAN). In this version (1977 SWMM), when surcharge occurs, the manholes connected to the surcharged pipes are assumed to have artificial cross sectional areas, decreasing in area from the pipe crown linearly to  $\frac{1}{4}$  of the pipe crown depth below the ground. The routing then proceeds as in the non-surcharged case. Excess water spilt out from manhole on to the ground is assumed lost and not recoverable. It has been found that this approach is also unsatisfactory and lacks theoretical justification.

In the French model CAREDas developed by SOGREAH, surcharge is handled by using the "Preissmann slot" technique (Preissmann and Cunge, 1961). In this method, the surcharged pipe flow is artificially converted into open-channel flow by assuming the existence of a slot on top and along the full length of the pipe (Fig. 2.1). The slot width is so narrow that its volume is negligible. Consequently, the open-channel flow dynamic equation can be applied to the slot-modified surcharge flow. However, if at any given time many pipes are surcharged, the solution becomes very expensive because the flow equations for all surcharged pipes (often for non-surcharged pipes as well) must be solved simultaneously. Approximate techniques to reduce the

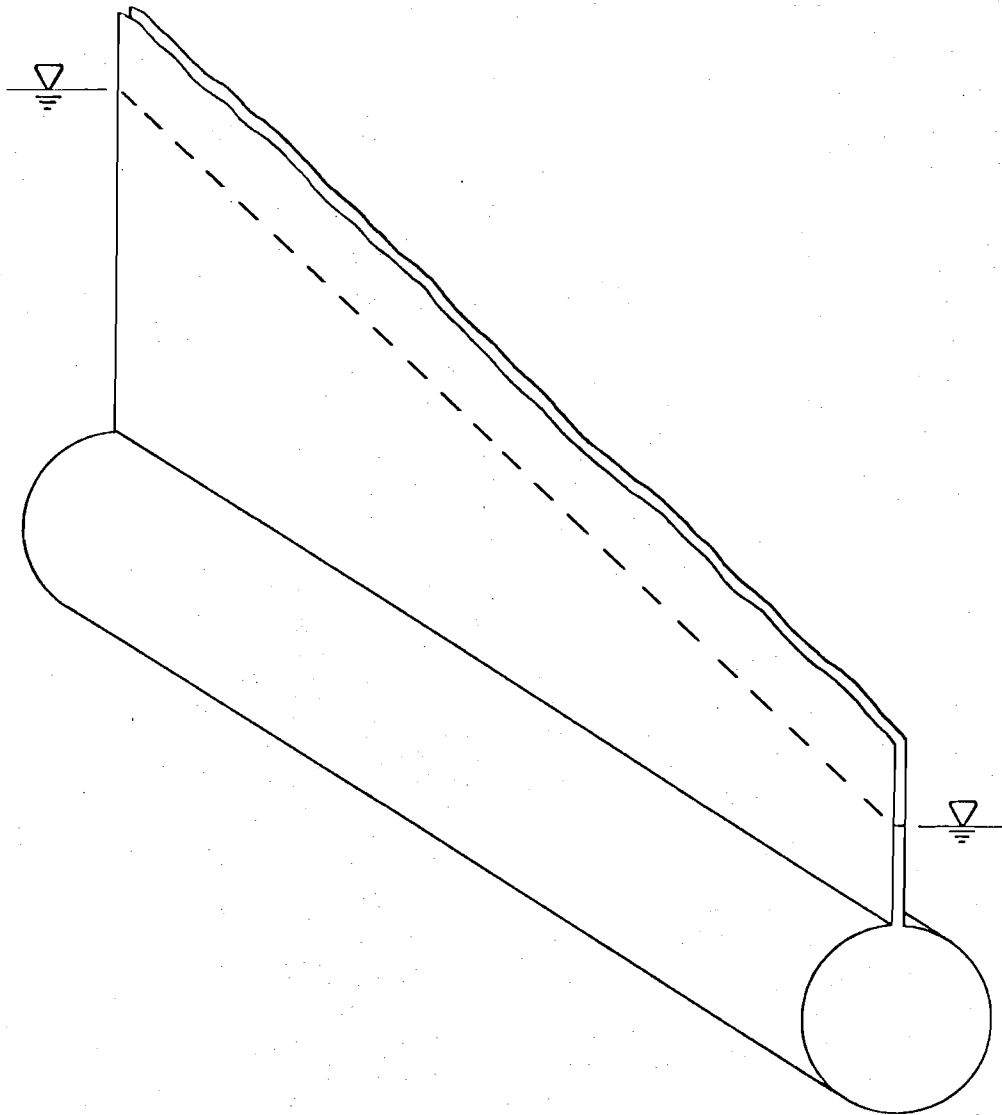

Fig. 2.1. Preissmann Slot

simultaneous computation, such as the over-lapping-segment method (Sevuk et al., 1973), are not very reliable when applied to the slot technique because pressure waves in surcharged pipes transmit farther upstream than is the case of open-channel flow. It has also been found that computational stability problems occur if the assumed slot width is too narrow, although not necessarily infinitesimal.

Song (1976, 1978) applied the method of characteristics to solve both the open-channel and surcharged phases of a simple sewer system. He assumed transition from open-channel flow to surcharged flow when the depth in the conduit exceeded a reference depth slightly smaller than the diameter of the pipe. The junction of the pipes were assumed as a point with a common water surface for all the joining pipes. Junction storage and losses were not directly accounted for.

Bettess et al. (1978) proposed an improved method to handle surcharged flow in sewer systems. The discharge of a pipe in the sewer system at any time is compared to the pipe-full discharge. If the former exceeds the latter, the pipe is assumed surcharged. In this manner, all surcharged pipes at a given time in the system are identified. The subsystem of surcharged pipes are then solved simultaneously using Darcy-Weisbach's formula together with the unsteady flow manhole continuity equation. The method is reasonably realistic, not excessively sophisticated, and practical. The major uncertainties are the manhole loss coefficients and the transient condition between open-channel and surcharged flows.

### 2.3. Other Related Previous Studies

Little has been done on an equally important problem of sewer surcharge, namely, the transition between surcharged and open-channel flow. Hydrodynamically, the transition phenomenon is one of the most difficult problems. It

involves not only unsteady nonuniform flow but also the complications of air entrainment, junction losses, and moving bores and surges (moving hydraulic jumps). Haindl (1957) investigated the transition of steady flow from open-channel to full pipe through a hydraulic jump. He found that the transition depends on the pre-jump Froude number and air supply in the pipe, and that the energy loss of the restrained hydraulic jump is less than or equal to the free hydraulic jump having the same pre-jump Froude number. Mayer-Peter and Favre (1932) first discussed the transient problem in the tailrace tunnel of the Wettigen Hydropower Plant. A brief review and discussion of the transient surges in a simple conduit can be found in Wiggert (1972). Zovne (1970) studied the propagation of bores and hydraulic jumps for unsteady open-channel flow using the method of characteristics. He concluded that the Saint Venant equations can be used provided certain precautions are taken.

Information on losses of Tee junctions for pipes can be found in the literature (e.g., Miller, 1971). However, data on junction losses in manholes are rather limited for steady flow cases and nonexistent for unsteady flows. Sangster et al. (1958) investigated experimentally the manhole losses of surcharged pipe flows. Townsend and Prins (1978) presented some experimental results on manhole loss coefficients under steady free-surface flows.

Volkart (1978) studied experimentally the air entrainment of steady flow in partially filled pipes of steep slopes. His results indicate that the air entrainment depends on the Froude number of the flow, the depth to pipe diameter ratio, and the slope and roughness of the pipe. Killen and Anderson (1968) investigated the interface characteristics and air entrainment of free surface flow. Dukler (1972), among others, discussed the stability of the interface between air and flowing liquid.



Perhaps the studies most familiar to hydraulic engineers which are relevant to sewer flow are the classifications of types of flows in culverts reported in Chow (1959), Portland Cement Association (1964), and U.S. Geological Survey (Bodhaine, 1969). The last classification is reproduced in Fig. 2.2. All these classifications of different types of flows are for steady flow in a single pipe. The actual flow cases for sewer networks are, especially for unsteady flows, considerably more complicated and will be discussed in the following chapter.

TYPE	EXAMPLE	TYPE	EXAMPLE
<p>1</p> <p>CRITICAL DEPTH AT INLET</p> <p><math>\frac{h_1 - z}{D} &lt; 1.5</math></p> <p><math>h_4 / h_c &lt; 1.0</math></p> <p><math>S_o &gt; S_c</math></p>	<p><math>Q = CA_c \sqrt{2g(h_1 - z + \alpha_1 \frac{V_1^2}{2g} - d_c - h_{f_{1-2}})}</math></p>	<p>4</p> <p>SUBMERGED OUTLET</p> <p><math>\frac{h_1 - z}{D} &gt; 1.0</math></p> <p><math>h_4 / D &gt; 1.0</math></p>	<p><math>Q = CA_o \sqrt{\frac{2g(h_1 - h_4)}{1 + \frac{29C^2 n^2 L}{R_o^3}}}</math></p>
<p>2</p> <p>CRITICAL DEPTH AT OUTLET</p> <p><math>\frac{h_1 - z}{D} &lt; 1.5</math></p> <p><math>h_4 / h_c &lt; 1.0</math></p> <p><math>S_o &lt; S_c</math></p>	<p><math>Q = CA_c \sqrt{2g(h_1 + \alpha_1 \frac{V_1^2}{2g} - d_c - h_{f_{1-2}} - h_{f_{2-3}})}</math></p>	<p>5</p> <p>RAPID FLOW AT INLET</p> <p><math>\frac{h_1 - z}{D} \approx 1.5</math></p> <p><math>h_4 / D \approx 1.0</math></p>	<p><math>Q = CA_o \sqrt{2g(h_1 - z)}</math></p>
<p>3</p> <p>TRANQUIL FLOW THROUGHOUT</p> <p><math>\frac{h_1 - z}{D} &lt; 1.5</math></p> <p><math>h_4 / D \approx 1.0</math></p> <p><math>h_4 / h_c &gt; 1.0</math></p>	<p><math>Q = CA_o \sqrt{2g(h_1 + \alpha_1 \frac{V_1^2}{2g} - h_3 - h_{f_{1-2}} - h_{f_{2-3}})}</math></p>	<p>6</p> <p>FULL FLOW FREE OUTFALL</p> <p><math>\frac{h_1 - z}{D} &gt; 1.5</math></p> <p><math>h_4 / D \approx 1.0</math></p>	<p><math>Q = CA_o \sqrt{2g(h_1 - h_3 - h_{f_{2-3}})}</math></p>

Fig. 2.2. U.S. Geological Survey Culvert Flow Classification (Bodhaine, 1968)

### III. THEORY OF SEWER NETWORK HYDRAULICS

Because of the temporal and spatial variations of rainfall events, storm sewer flows are generally unsteady, i.e., time-varying. The pattern of sewer runoff due to a surcharge-causing heavy rainstorm is such that open-channel flow occurs in the sewer before and after the surcharge. Therefore, the entire range of flow conditions should be considered if a complete investigation of sewer surcharge is desired. As a matter of convenience, in this report the entire range of flow is divided into three regimes. They are open-channel or free-surface or gravity flow, pressurized-conduit or surcharged flow, and the transition between the open-channel and surcharged flows.

A sewer system is a network of manholes or junctions (nodes) connected by sewer pipes (links). Usually storm sewer networks are considered as the dendritic type network, although loop-type networks do exist. There are, of course, other regulatory and control facilities in sewer systems. However, in this report the emphasis is on the behavior of the manholes and pipes, and the auxiliary facilities are not considered.

#### 3.1. Flow in a Sewer Pipe

##### 3.1.1. Classification of Flow in Single Pipe

The first step toward understanding the flow in a sewer system is to understand the flow in a single sewer pipe. The flow in a sewer pipe, similar to that in a culvert, has three regions; namely, the entrance, the pipe flow, and the exit. There are four cases of entrance conditions as listed in Table 3.1 and illustrated in Fig. 3.1. Case I is associated with downstream control of the pipe flow. Case II is associated with upstream control of the pipe flow. In Case III the pipe flow under the air pocket may be subcritical, supercritical, or transitional. In Case IV the pipe flow is often controlled by the downstream condition but sometimes by both entrance and downstream conditions.

TABLE 3.1. PIPE ENTRANCE CONDITIONS

Case	Hydraulic Condition
I	Nonsubmerged entrance, subcritical flow
II	Nonsubmerged entrance, supercritical flow
III	Submerged entrance, air pocket
IV	Submerged entrance, "water pocket"

TABLE 3.2. PIPE EXIT CONDITIONS

Case	Hydraulic Condition
A	Nonsubmerged, free fall
B	Nonsubmerged, continuous
C	Nonsubmerged, hydraulic jump
D	Submerged

The exit conditions can also be grouped into four cases as listed in Table 3.2 and illustrated in Fig. 3.2. In Case A the pipe flow is under exit control. In Case B the flow is under upstream control if it is supercritical and downstream control if subcritical. In Case C the pipe flow is under upstream control with the manhole water surface under downstream control. In Case D the pipe flow is often under downstream control but can also be under both upstream and downstream control.

As to the flow within the pipe, it can be subcritical or supercritical open-channel flow, uniform or nonuniform, with or without a hydraulic jump or drop, gravity flow or surcharged, and usually turbulent. Without taking into consideration the different modes of air entrainment, the pipe flow can be classified into ten groups as listed in Table 3.3 and illustrated in Fig. 3.3. The possible entrance and exit conditions for each of the ten pipe flow cases

are also given in Table 3.3. Therefore, considering the pipe flow together with its possible entrance and exit conditions, there are 29 possible cases altogether just for one pipe. Furthermore, additional sub-cases exist since storm sewer flows are unsteady. For example, for open-channel flow the sub-cases can be with a rising, falling, or stationary free surface. For the cases with a hydraulic jump or drop, the jump or drop may be moving upstream, downstream, or stationary.

TABLE 3.3. PIPE FLOW CONDITIONS

Case	Pipe Flow	Possible Entrance Case	Possible Exit Case
1	Subcritical	I, III	A,B
2	Subcritical → hydraulic drop → supercritical	I, III	B,C
3	Supercritical	II, III	B,C
4	Supercritical → hydraulic jump → subcritical	II, III	A,B
5	Supercritical → hydraulic jump → surcharge	II, III	D
6	Surcharge → supercritical	IV	B,C
7	Surcharge → subcritical	IV	A,B
8	Subcritical → surcharge	I, III	D
9	Supercritical → surcharge	II, III	D
10	Surcharge	IV	B,C,D

It should be mentioned here that the flow conditions given in Table 3.3 apply to steady flow as well. However, Case 6 is rare for unsteady flow and does not occur at all for steady flow. Therefore, 27 possible steady flow cases exist, of which some are rather rare, e.g., pipe flow Cases 2, 7, and 9 seldom occur in steady flow. The cases described in Chow (1959), Portland Cement Association Handbook (1964), Bodhaine (1968), and other literature are the major cases that are often observed. As an example, Bodhaine's types of flow shown in Fig. 2.2 are identified in Table 3.4 according to the classifications in Table 3.3.

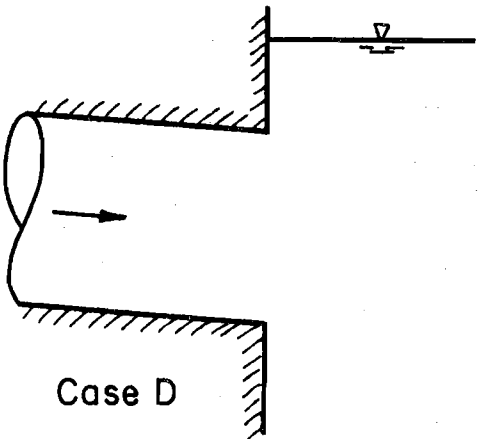
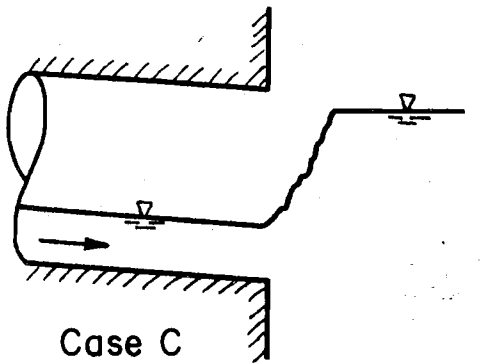
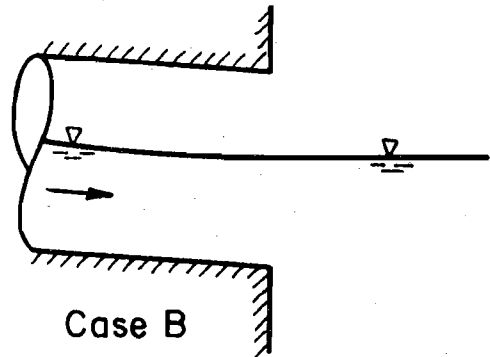
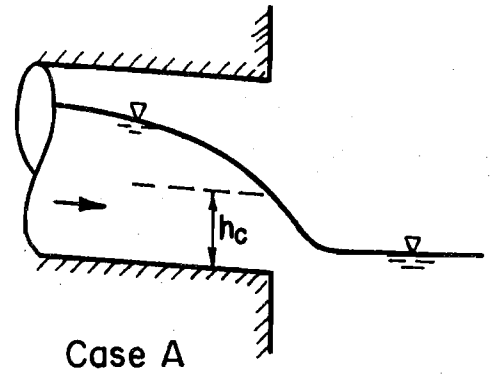
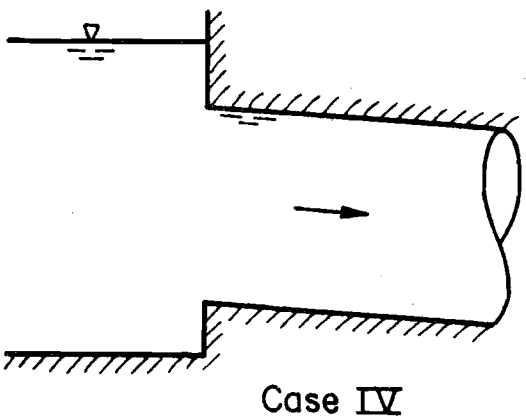
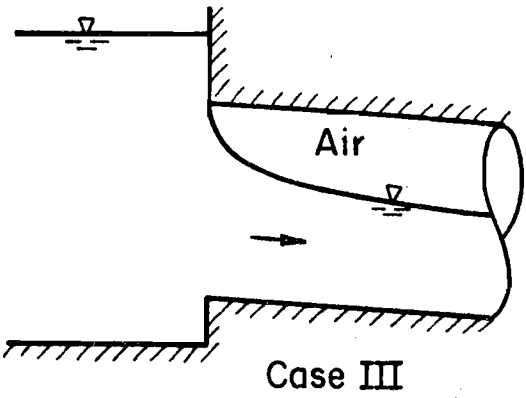
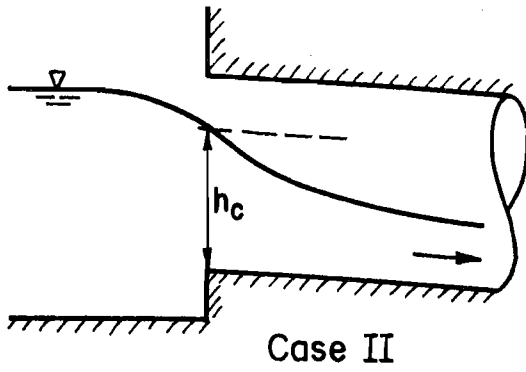
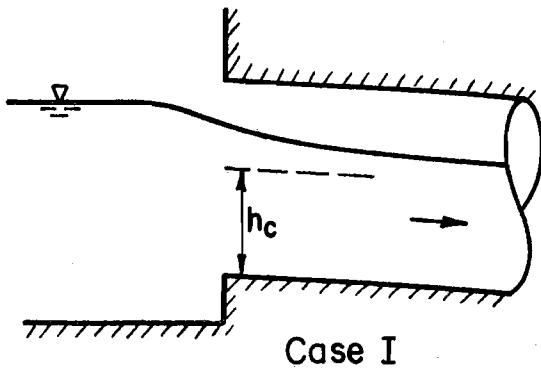

Fig. 3.1. Sewer Exit Flow Cases

Fig. 3.2. Sewer Entrance Flow Cases

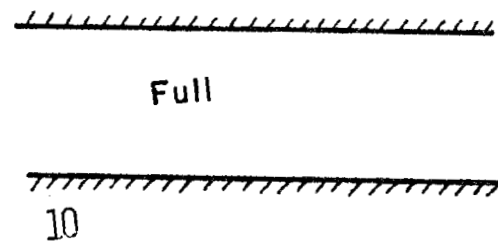
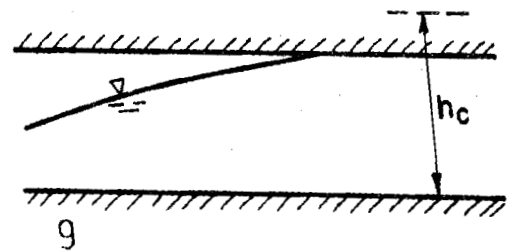
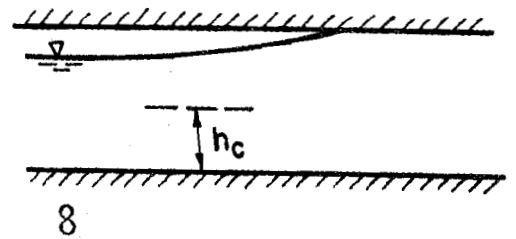
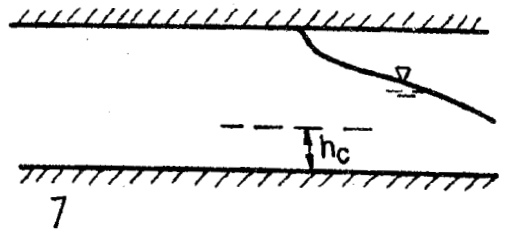
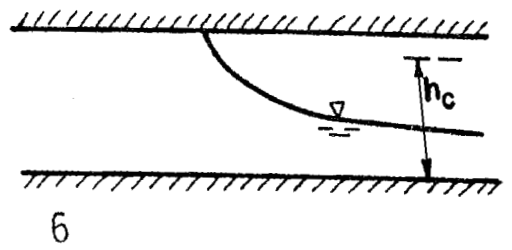
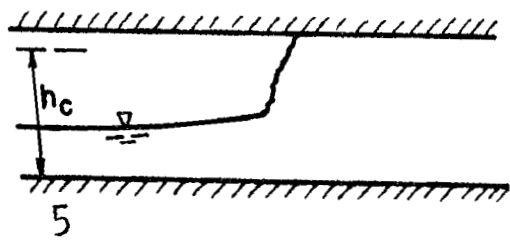
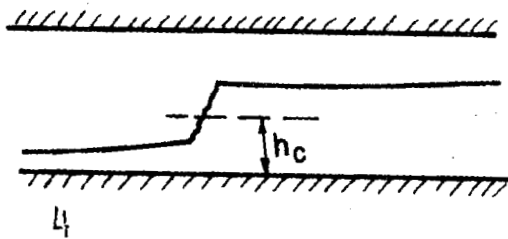
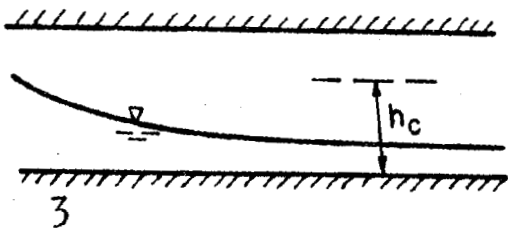
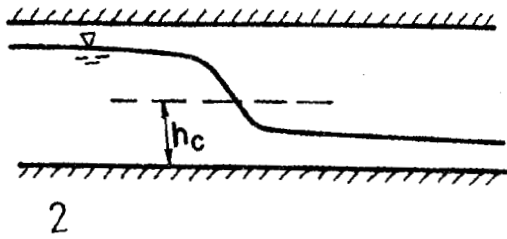
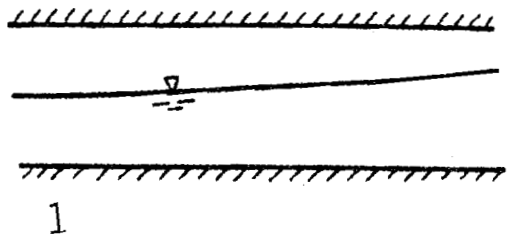

Fig. 3.3. Classification of Flow in a Sewer

TABLE 3.4. IDENTIFICATION OF BODHAINE'S TYPES OF PIPE FLOW

Bodhaine's Type of Flow (Fig. 2.2)	Classification According to Table 3.3.
1	II-3-B or C
2	I-1-A
3	I-1-B
4	IV-10-D
5	III-3-B
6	IV-10-B

### 3.1.2. Hydraulic Behavior of Flow in Single Pipe

There are a number of unsolved hydrodynamic problems encountered during the process of the flow in a storm sewer starting from dry or nearly dry bed to surcharge and then back to the nearly dry bed. The problems of air entrainment, entrance and exit losses of the pipe at connecting manholes, and a moving surface discontinuity (moving hydraulic jump or drop) have been mentioned in Section 2.3.

Yen (1978a) described five types of hydraulic instabilities in sewer systems, one of which is the surge instability of a network. The other four types of instabilities occur in single sewer pipes and are discussed briefly as follows.

- (A) A near dry-bed flow instability which is dominated by the surface tension effect. This instability is not important for surcharged flow.
- (B) The transition instability between supercritical and subcritical flow. As mentioned previously, this instability is particularly difficult to handle if the flow is unsteady and the surface discontinuity is moving.
- (C) Water-surface roll-wave instability which is dominated by gravity effects and usually associated with open-channel flow having a Froude number greater than 2. Figure 3.4 is a sketch of the roll waves. If the height of



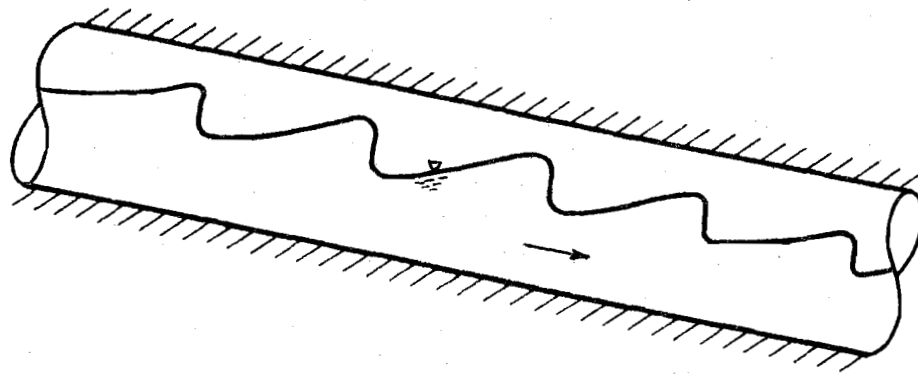

Fig. 3.4. Roll Waves in a Sewer

the roll wave is large in comparison with the size of the sewer pipe, full-pipe flow may occur intermittently because of the roll waves, especially if the air entrainment problem occurs simultaneously.

- (D) The instability at the transition between open-channel flow and full conduit flow. This instability is most relevant to sewer surcharge. There are several factors causing this instability, including (a) non-unique discharge-depth relationship when the pipe is nearly full, (b) insufficient air supply to maintain an air pocket at the pipe entrance, (c) surface tension effect of the pipe crown when the pipe is nearly full, and (d) surface waves, especially roll waves. These factors may act individually or in combination to cause the instability problem.

To illustrate the first factor of non-unique discharge-depth relationship, consider the relatively simple case of steady flow in a circular pipe as an example. The nondimensional discharge-depth relationship for steady, uniform, open-channel flow and the discharge-piezometric pressure gradient relationship for steady uniform flow in a closed conduit is shown schematically in Fig. 3.5. In the open-channel flow regime, the maximum discharge does not occur at the

depth,  $h$ , equal to the pipe diameter,  $D$ . It occurs at approximately  $h = 0.94 D$ , varying slightly depending on the Reynolds number of the flow. This decrease in discharge when the pipe is nearly filled is due to the rapid increase in wetted perimeter as  $h$  approaches  $D$ , and the consequent increase in the pipe boundary resistance to the flow. As shown in Fig. 3.5, the relationship between the discharge and depth or piezometric gradient is unique above point E or below point J. Between points J and E a given discharge can have different depths or piezometric gradient.

To illustrate the second factor of insufficient air supply in the pipe to maintain a stable air pocket, consider the simple case of a submerged pipe entrance as shown in Fig. 3.6. Assume that initially the discharge entering the pipe is  $Q_e$  corresponding to the manhole depth and water surface profile  $\alpha$  with the air pocket shown in Fig. 3.6. This profile is classified as Type III-5-D with small exit submergence in Table 3.3. Since the sewer is not ventilated and its downstream part is sealed by the hydraulic jump in the pipe, entrainment of the trapped air into the flowing water creates a low pressure in the air pocket (a situation similar to under-ventilated weir or sluice gate). Subsequently, the discharge into the sewer increases while the depth in the upstream manhole drops. One possibility is that the higher discharge ( $>Q_e$ ) pushes the hydraulic jump outside the pipe, allowing air to enter, resulting in atmospheric pressure for the air in the pipe. This is shown as surface profile  $\lambda$  in Fig. 3.6 and is Case III-3-C in Table 3.3. Consequently, the discharge drops ( $<Q_e$ ), the hydraulic jump occurs inside the pipe again, and the cycle repeats.

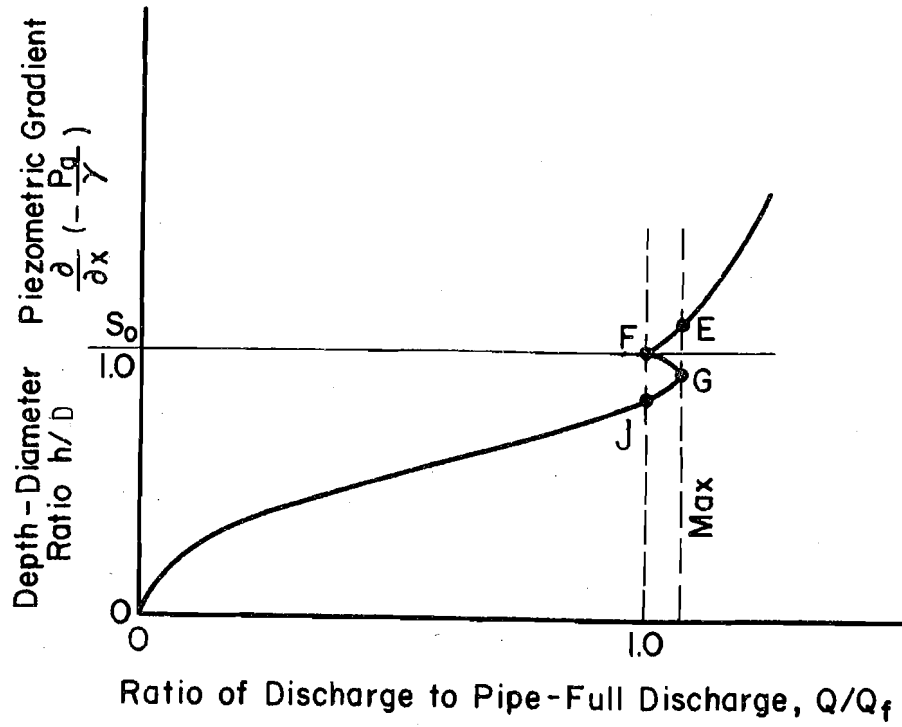

Fig. 3.5. Discharge Rating Curve for Steady Flow in a Circular Pipe

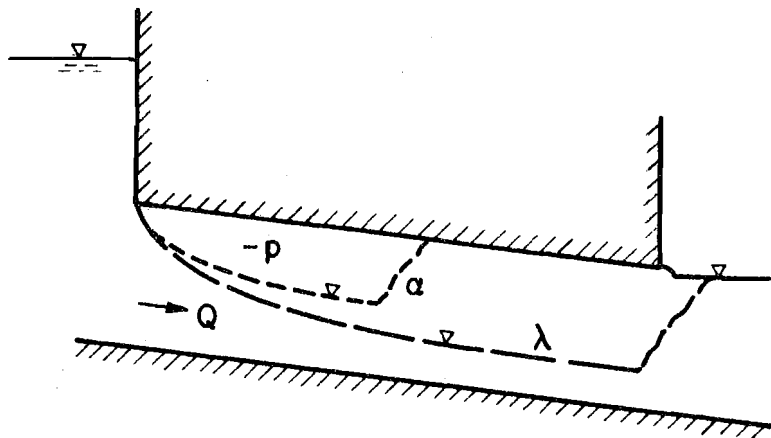

Fig. 3.6. Air Entrainment Instability in a Sewer

### 3.1.3. Mathematical Representation of Flow in a Pipe

The open-channel phase of the sewer flow can be represented mathematically by a pair of partial differential equations of hyperbolic type (Yen, 1973, 1975)

$$\frac{\partial A}{\partial t} + \frac{\partial Q}{\partial x} = 0 \quad (3.1)$$

$$\begin{aligned} \frac{1}{gA} \frac{\partial Q}{\partial t} + \frac{1}{gA} \frac{\partial}{\partial x} \left( \frac{\beta}{A} Q^2 \right) + \cos \theta \frac{\partial}{\partial x} (Kh) + (K - K') h \cos \theta \frac{1}{A} \frac{\partial A}{\partial x} \\ = S_o - S_f + \frac{1}{\gamma A} \frac{\partial T}{\partial x} \end{aligned} \quad (3.2)$$

in which  $Q$  is discharge;  $t$  is time;  $x$  is the distance along the pipe longitudinal direction;  $A$  is flow cross sectional area perpendicular to  $x$ ;  $h$  is flow depth measured normal to  $x$ ;  $\theta$  is the angle between the sewer axis and a horizontal plane (Fig. 3.7);  $S_o = \sin \theta$  is the sewer slope;  $S_f$  is the friction slope;  $\beta$  is a momentum flux correction factor;  $K$  and  $K'$  are correction factors for nonhydrostatic pressure distribution;  $T$  represents the force due to internal stresses acting normally to  $A$ ;  $\gamma$  is the specific weight of the liquid, assumed incompressible and homogeneous; and  $g$  is gravitational acceleration. Equation 3.1 is the continuity equation and Eq. 3.2 is the momentum equation. They are derived from the principle of conservation of mass and Newton's second law, respectively.

Because of the difficulties in solving Eqs. 3.1 and 3.2, in practice they are simplified by assuming  $\beta = 1$  (uniform velocity distribution over  $A$ ), hydrostatic pressure distribution ( $K = K' = 1$ ), and neglecting the last term in Eq. 3.2 containing  $T$ . The result is the well known complete (but not exact) dynamic wave or Saint Venant equations,

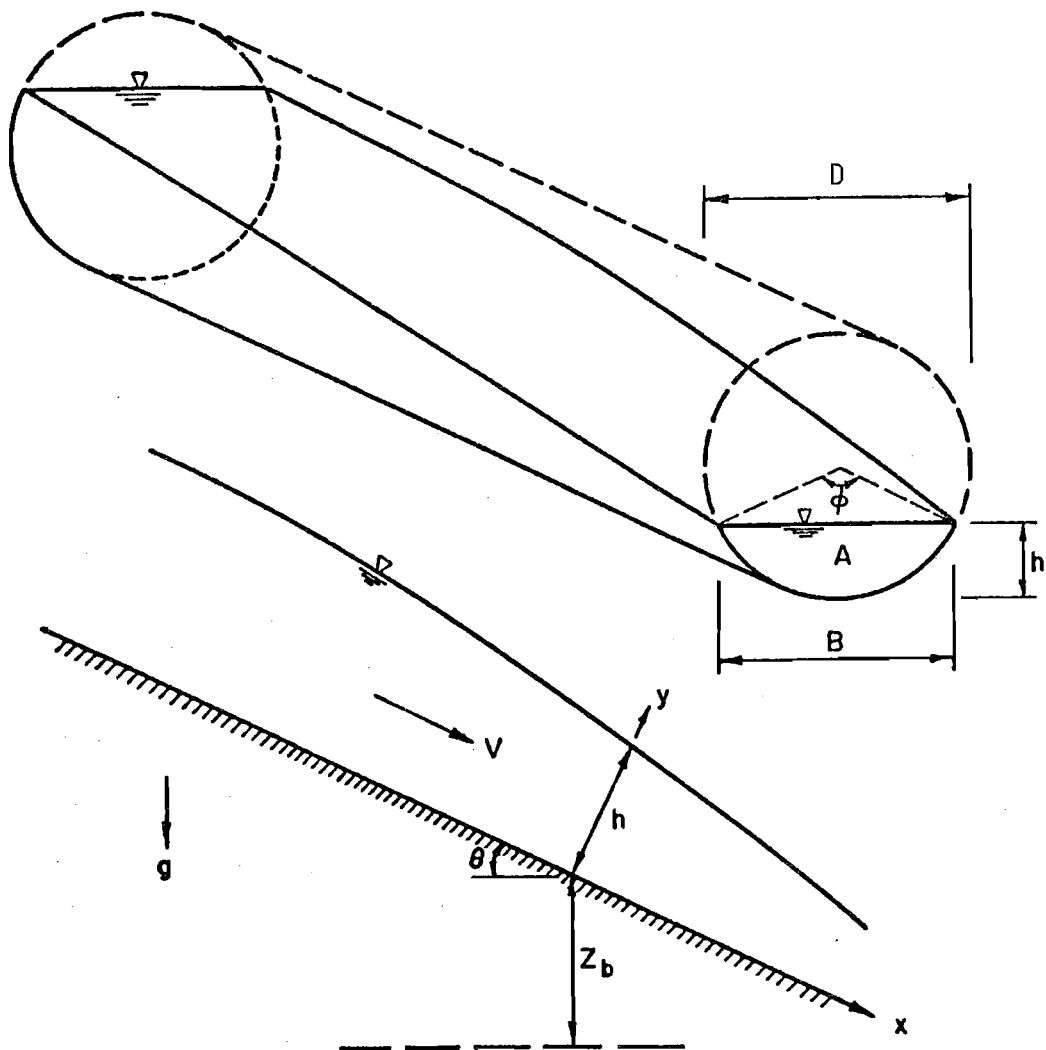

Fig. 3.7. Open-Channel Flow in a Sewer

$$\frac{\partial A}{\partial t} + \frac{\partial Q}{\partial x} = 0 \quad (3.1)$$

$$\frac{1}{gA} \frac{\partial Q}{\partial t} + \frac{1}{gA} \frac{\partial}{\partial x} \left( \frac{Q^2}{A} \right) + \cos \theta \frac{\partial h}{\partial x} - (S_o - S_f) = 0 \quad (3.3)$$

Alternatively, Eqs. 3.1 and 3.3 can be expressed in terms of the average velocity,  $V$ , over the cross sectional area  $A$ , i.e.,

$$\frac{\partial h}{\partial t} + \frac{A}{B} \frac{\partial V}{\partial x} + V \frac{\partial h}{\partial x} = 0 \quad (3.4)$$

$$\frac{1}{g} \frac{\partial V}{\partial t} + \frac{V}{g} \frac{\partial V}{\partial x} + \cos \theta \frac{\partial h}{\partial x} - (S_o - S_f) = 0 \quad (3.5)$$

in which  $B$  is the water surface width.

In the surcharged phase, the flow cross-sectional area is constant equal to the full pipe area  $A_f$ . The continuity and momentum equations can be written as

$$Q = A_f V \quad (3.6)$$

$$\frac{1}{g} \frac{\partial V}{\partial t} + \frac{\partial}{\partial x} \left( \frac{\beta V^2}{g} + \frac{P_a}{\gamma} \right) = -S_f + \frac{1}{\gamma A} \frac{\partial T}{\partial x} \quad (3.7)$$

in which  $P_a$  is the piezometric pressure of the flow and other symbols are as previously defined. For a pipe having constant cross-section and flowing full throughout its length,  $\partial V / \partial x = 0$ . By neglecting the spatial variation of  $\beta$  and  $T$ , integration of Eq. 3.7 over the entire length,  $L$ , of the sewer pipe yields

$$\frac{P_a}{\gamma} \Bigg|_{\text{entrance}}^{\text{exit}} = H_u - H_{\text{exit}} - K_u \frac{V^2}{2g} = L (S_f + \frac{1}{g} \frac{\partial V}{\partial t}) \quad (3.8)$$

in which  $H_u$  and  $H_{\text{exit}}$  are the total head at the entrance and exit of the pipe, respectively (Fig. 3.8); and  $K_u$  is the entrance loss coefficient.

Equations 3.6 and 3.7 can be derived as a special case of Eqs. 3.1 and 3.2. This, indeed, is the theoretical basis of the Preissmann slot technique (Preissmann and Cunge, 1961).

The friction slope,  $S_f$ , is usually estimated by using Manning's formula

$$S_f = \frac{n^2 V^2}{2.22} R^{-4/3} = \frac{n^2 Q^2}{2.22 A^2} R^{-4/3} \quad (3.9)$$

or the Darcy-Weisbach formula,

$$S_f = \frac{f}{8gR} V^2 = \frac{f}{8gR} \frac{Q^2}{A^2} \quad (3.10)$$

in which  $n$  is Manning's roughness factor;  $f$  is the Weisbach resistance coefficient; and  $R$  is the hydraulic radius which is equal to  $A$  divided by the wetted perimeter. These two equations are applicable to both surcharged and open-channel flows. For the open-channel case the pipe is flowing partially filled and the geometric parameters of the flow cross section are computed as follows

$$A = \frac{D^2}{8} (\phi - \sin \phi) \quad (3.11)$$

$$R = \frac{D}{4} \left( 1 - \frac{\sin \phi}{\phi} \right) \quad (3.12)$$

$$B = D \sin \frac{\phi}{2} \quad (3.13)$$

$$h = \frac{D}{2} \left( 1 - \cos \frac{\phi}{2} \right) \quad (3.14)$$

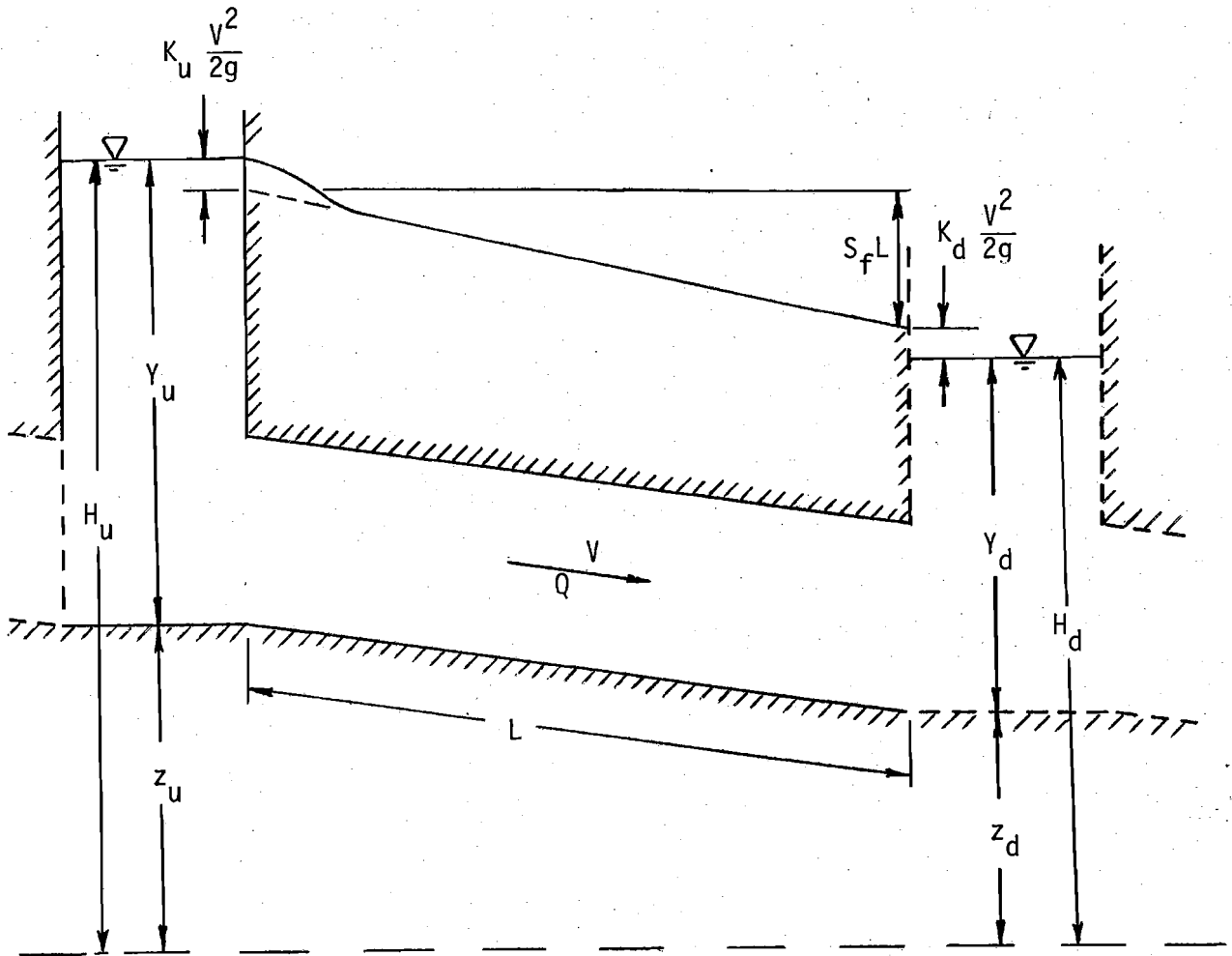

Fig. 3.8. Surcharged Flow in a Sewer



in which  $D$  is the diameter of the pipe and  $\phi$  is the central angle in radians described by the water surface having a width  $B$  (Fig. 3.7). If the flow is assumed steady and uniform, Eqs. 3.3 or 3.5 reduce to  $S_o = S_f$  and  $Q = AV$ .

Hence, from Eq. 3.9 for steady uniform flow using Manning's formula

$$Q = \frac{C}{n} S_o^{1/2} D^{8/3} \frac{(\phi - \sin\phi)^{5/3}}{\phi^{2/3}} \quad (3.15)$$

in which the constant  $C = 0.0737$  for English units and  $0.0496$  for SI units.

Correspondingly, the Darcy-Weisbach formula (Eq. 3.10) yields

$$Q = \frac{1}{8} \sqrt{\frac{2gS_o}{f}} D^{5/2} \frac{(\phi - \sin\phi)^{3/2}}{\phi^{1/2}} \quad (3.16)$$

Advanced techniques for solving storm sewer flow problems usually adopt Eqs. 3.1 and 3.3 or Eqs. 3.4 and 3.5 to simulate the open-channel flow phase of the sewer flow and Eqs. 3.6 and 3.8 to simulate the surcharged flow.

## 3.2. Flow in a Sewer Network

### 3.2.1 Sewer Junctions

The sewers in a network are joined by manholes and junctions. There are one-way manholes or junctions, for which there is only one pipe connected to the manhole. This is the case for the most upstream manhole which receives surface runoff directly through the inlets. Two-way junctions have two pipes connected to a junction. They are usually provided for a change in alignment, pipe size, or slope. A three-way junction (or Y-junction) has three pipes connected to it. A four-way (or fork) junction has four pipes connected to the junction. Junctions joining more than four pipes exist in special situations.

Hydraulically, a junction imposes three major effects. First, it provides a space for storage. Second, it dissipates the kinetic energy of the flow

from joining sewers. Third, it imposes backwater effects to the sewers connected at the junction. The precise hydraulic description of the flow at sewer junctions is rather complicated and difficult because of the high degree of flow mixing, separation, turbulence, and energy losses. Yet correct representation of the junction hydraulics is important in realistic and reliable computation of flow in sewer systems.

Mathematically, the junction hydraulic condition is usually described by a continuity equation and sometimes aided by an energy equation. The momentum equation is rarely used because it is a vector relationship and the changes of momentum and forces are difficult to evaluate in a junction. The principle of conservation of mass gives the following continuity equation

$$\sum Q_i + Q_j = \frac{ds}{dt} \quad (3.17)$$

in which  $Q_i$  is the flow into or out from the junction by the  $i$ -th joining sewer, being positive for inflow and negative for outflow;  $Q_j$  represents the direct, temporally variable water inflow into (positive) or the pumpage or leakage out from (negative) the junction, if any;  $s$  is the storage in the junction; and  $t$  is time. For a manhole of constant cross-sectional area,  $A_j$ ,  $s = A_j Y$  where  $Y$  is the depth in the junction (Fig. 3.9). Noting that  $Y$  is related to the manhole water surface elevation  $H$  by  $H = Y + z$  (Fig. 3.8), when  $z$  is the elevation of the junction bottom.

$$\frac{ds}{dt} = A_j \frac{dH}{dt} \quad (3.18)$$

In regard to the energy relationship, an exact energy budget account of the flow through junction is impractical; if not impossible. Instead,

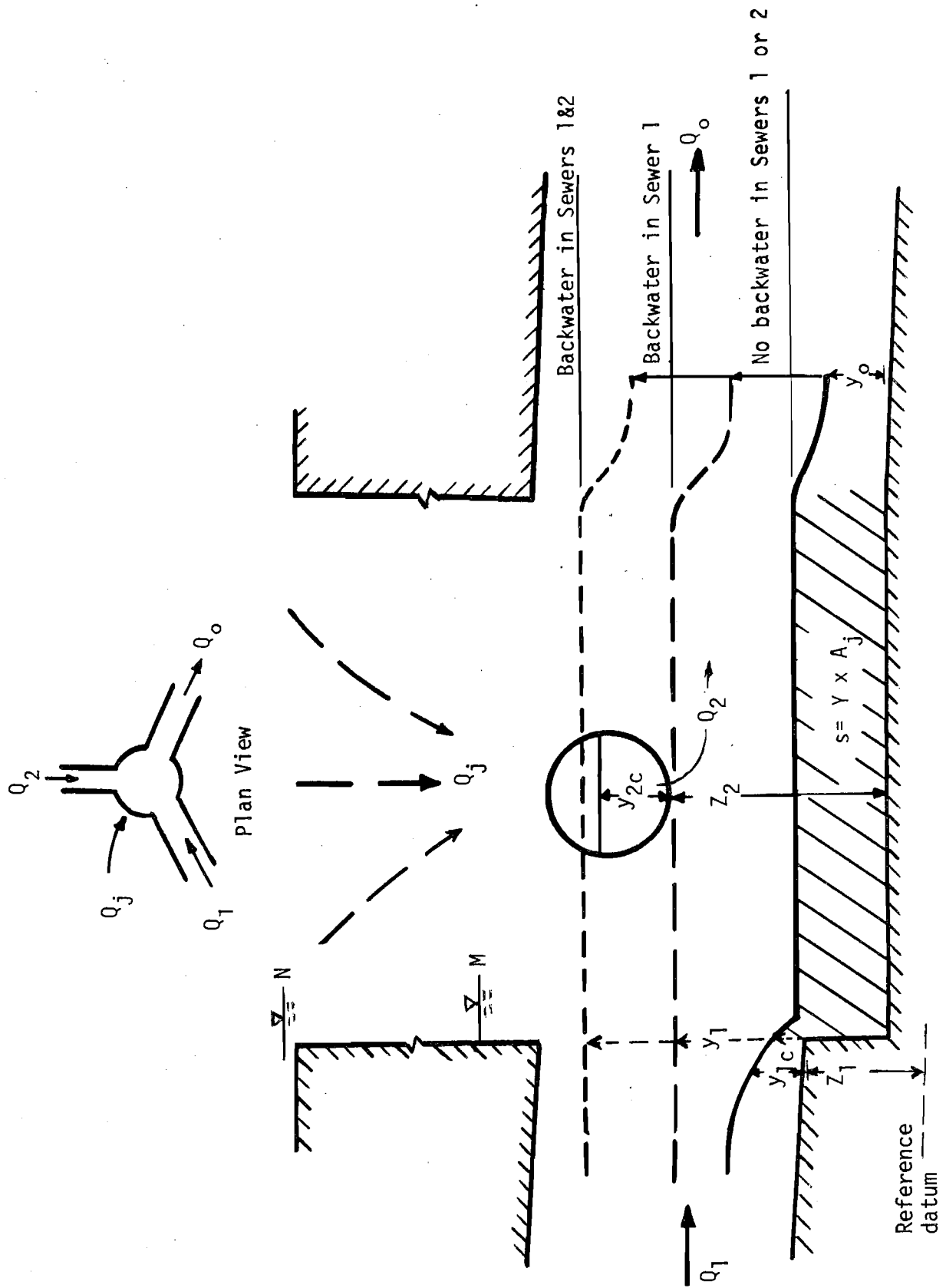

Fig. 3.9. Schematic Drawing of Sewer Junction

approximate energy expressions are assumed. For a submerged entrance from the junction into a surcharged downstream pipe (Case IV, Fig. 3.1) the flow behaves like an orifice and the head loss through the entrance is  $K_u V^2/2g$  where  $K_u$  is the entrance loss coefficient and  $V$  is the velocity in the downstream pipe. Accordingly, the instantaneous discharge from the junction into the downstream pipe can be estimated from  $Q = AV$  where the velocity  $V$  is given by Eq. 3.8. For a sharp-edged abrupt entrance, the value of  $K_u$  is approximately equal to 0.5 (Rouse, 1950).

For Case III in Fig. 3.1, where the entrance of the out-flowing downstream pipe is submerged but the pipe is not filled, the flow near the entrance behaves somewhat like a sluice gate. The outflow rate from the junction is  $Q = AV$  where  $A$  and  $V$  are the flow cross sectional area and velocity at the vena contracta, respectively. The velocity can be estimated by using

$$V = C_v \sqrt{2g\Delta H} \quad (3.19)$$

in which  $\Delta H$  is the piezometric head difference between the water surface in the junction and the vena contracta. The corresponding entrance head loss is  $(1-C_v^2)\Delta H$ .

For the case of flow from the junction into a downstream sewer with a non-submerged entrance (Cases I and II in Fig. 3.1) the water depth in the junction is assumed equal to the entrance loss plus the specific energy of the flow at the pipe entrance. Thus,

$$H = \frac{V^2}{2g} + y + z + K_u \frac{V^2}{2g} \quad (3.20)$$

in which  $z$  is the height of the pipe invert above the reference datum and  $y$  is the depth of flow measured vertically at the entrance of the pipe. Note that for Case II in Fig. 3.1  $y = y_c$  at the sewer entrance.

Now consider the inflows into a junction. For an upstream pipe discharging into the junction, if the exit of the pipe is submerged (Case D, Fig. 3.2.), the water surface in the junction is assumed equal to the total head of the flow at the pipe exit minus the exit loss. Thus,

$$H = \frac{P_a}{\gamma} \Big|_{\text{exit}} + \frac{V^2}{2g} - K_d \frac{V^2}{2g} = H_{\text{exit}} - K_d \frac{V^2}{2g} \quad (3.21)$$

in which the piezometric head  $P_a/\gamma$  is measured from the reference datum,  $V$  is the velocity at the pipe exit, and  $K_d$  is the exit loss coefficient. If the kinetic energy of the junction inflow is assumed to be completely lost,  $K_d = 1$ . This is a gross assumption because, unless the junction is very large, part of the kinetic energy may be recovered in the outflow from the junction into the downstream sewer. This energy recovery depends on, among other factors, the alignment of upstream and downstream pipes and the size of the junction.

If the upstream inflowing pipe is not submerged at its exit into the junction and the flow in the pipe is subcritical (Case A and B in Fig. 3.2), then

$$y + z + (1 - K_d) \frac{V^2}{2g} = H \quad \text{if } y_c + z < H \quad (3.22a)$$

$$y = y_c \quad \text{otherwise} \quad (3.22b)$$

in which  $z$  is the height of the pipe invert at its exit measured above the reference datum,  $y$  is the pipe flow depth measured vertically at its exit, and  $y_c$  is the critical depth corresponding to the instantaneous flow rate  $Q$  at the pipe exit (Fig. 3.9).

For the above three cases of flow into a junction (submerged exit or subcritical flow), the flow in the upstream pipe is directly affected by the water depth in the junction, except for the condition of Eq. 3.22b (Case A, Fig. 3.2). This is commonly known as the downstream backwater effect. If the flow at the exit of the upstream pipe is supercritical (Cases B and C in Fig. 3.2), the flow in the upstream pipe is not affected by the water depth in the junction. The water depth in the junction is determined by the junction continuity equation (Eq. 3.17) and the energy equation, i.e.,

$$y + z + (1 - K_d) \frac{V^2}{2g} = H \quad (3.23)$$

if no hydraulic jump occurs in the junction. If a hydraulic jump occurs in the junction which is a highly unlikely case,

$$y + z + (1 - K_d) \frac{V^2}{2g} - H_{f\text{-jump}} = H \quad (3.24)$$

in which  $H_{f\text{-jump}}$  represents the head loss of the hydraulic jump.

### 3.2.2. Sewer Networks

With the hydraulics of individual sewers described mathematically as discussed in Section 3.1 and the hydraulics of individual junctions mathematically

represented as discussed in Section 3.2.1 , the problem of storm runoff in a sewer network can theoretically be solved using physical principles. In truth, not a single sewer network consisting of more than a few (say 10) pipes has so far been solved satisfactorily using the basic hydrodynamic principles without making use of any assumptions or artificially imposed controls. There are many reasons for this difficulty, such as

- (a) the Saint Venant equations are not exact (Yen, 1973, 1975);
- (b) the flow resistance coefficient, whether it is in the Manning, Chezy, or Darcy-Weisbach form, is unknown for unsteady nonuniform flow;
- (c) the energy loss coefficients at the junctions ( $K_u$  for pipe entrance loss and  $K_d$  for pipe exit loss) are geometry dependent and unknown for unsteady flow;
- (d) the mathematical difficulties of solving the Saint Venant equations or similar hyperbolic type partial differential equations;
- (e) the hydraulic instability problems including pressure surge and the change between open-channel and pressurized conduit flows; and
- (f) the backwater effect, i.e., the mutual dependence of the flow in the connecting pipes.

Some of these reasons do not impose serious problems. For instance, the Saint Venant equations, although not exact, have been shown to be good approximations even for supercritical flow (Zovne, 1970). The steady-flow resistance and energy coefficients can be used as approximations. Mathematical difficulties have been reduced with the improvement and development of computer capability and numerical techniques.

The hydraulic stability problems for a sewer pipe have been discussed in Section 3.1.2. For a sewer network with the pipes surcharged, there is a pressure surge instability due to the interaction between pressurized conduits.

Surges in the sewers are pressure waves similar to waterhammer in pipe networks for which previous studies have been reviewed briefly in Chapter 2. The surges may be due to the meeting of flood waves from different sewer branches at a junction, due to sudden surcharges of manholes or pipes, or due to any other abrupt change of the flow. It has even been observed in many locations that surges of water spilled out from manholes onto the ground surface. The theory to analyze the surge instability has been developed. It needs only to be refined and applied to sewer networks. It should be mentioned that since pressure is transmitted immediately, the surges in the sewers and manholes are mutually related and there is a possibility of resonance.

The primary reason for the difficulties in solving sewer network flow accurately using the physical principles is the mutual backwater effects between the sewers. In fact, a major difference between the flow through a culvert and a sewer network is the network effect for the latter. The effect of backwater in a sewer network cannot be over-emphasized, particularly for the case of surcharged sewers, as can be demonstrated through the following rather simplified example.

Figure 3.10 is a schematic drawing of a sewer in the Oakdale Avenue Drainage Basin in Chicago. The 10-in. sewer is 170 ft long running north along Leclaire Avenue from an alley to the intersection of Oakdale and Leclaire Avenues. The sewer has a slope of 0.71% and a Manning roughness factor  $n = 0.014$ . In a conventional calculation, the sewer flow is computed using the sewer slope as the flow slope, i.e., corresponding to the water surfaces U and C in the upstream and downstream manholes, respectively. Using Manning's formula and assuming steady uniform flow, the computed discharge is 1.72 cfs. In reality, even for a given upstream manhole having



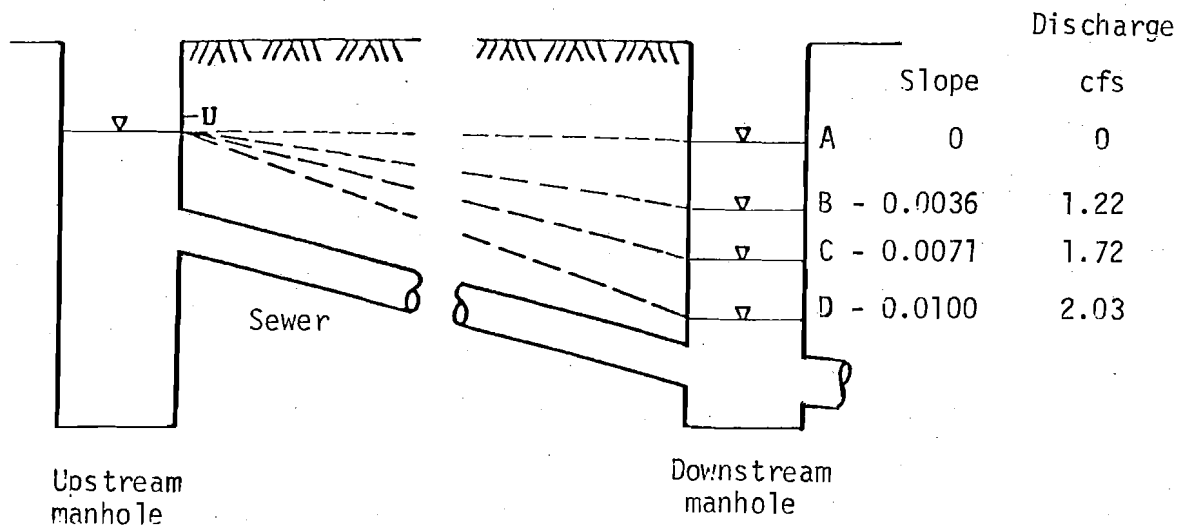

Fig. 3.10. Backwater Effect on Discharge of an Oakdale Avenue Sewer

a water surface at U, the downstream manhole level can be lower or higher than level C. If the level is lower, the discharge will be greater than 1.72 cfs; whereas if the level is higher, the discharge will be smaller. Obviously, if the downstream level is at A, the same elevation as in the upstream manhole, there will be no flow in the sewer.

The actual hydraulic phenomena, of course, are considerably more complicated than this simplified idealized example because the flow is unsteady and there is more than one sewer in the network imposing mutual backwater effects. Moreover, if the manholes are fully surcharged, the overland surface flow between the manholes will interact with the sewer flow. In most engineering computation of sewer flows, the effects of flow unsteadiness, of the changes of water surfaces in the connecting junctions, and of the interaction between surcharged sewer and surface flows are simply ignored. The sewer capacity is simply computed as full-pipe gravity flow, equal to the flow under the head difference between water surfaces U and C shown in Fig. 3.10. The excessive flow above the computed sewer capacity is often assumed to store in the immediate upstream junction. Likewise, the water level in the junction is not computed while the excess stored water is assumed to impose no effect on the

flows in the other sewers connecting to the junction. Handling the surcharge in such a manner is simply erroneous, not an approximation as many engineers have thought, and it can result in dangerous and costly conclusions for urban sewer flow management.

As discussed in Section 3.1.1, for a single sewer there are 29 possible flow cases (Table 3.3). For a two-way junction there are  $29^2 = 841$  possible cases. For a three-way junction, there are  $29^3 = 24,389$  cases. In general, if there are  $N$  possible flow cases in each sewer, for an  $m$ -way junction the possible cases are  $N^m$  assuming no reversal flow occurs in any one of the  $m$  sewers. For a three-way junction, if two of the sewers are inflow sewers for which the order of occurrence of the flows in the two sewers are immaterial and interchangeable (e.g., in the flow identification, the flow case of II-3-B in Sewer 1 and IV-10-B in Sewer 2 is considered as the duplicate of the reverse case of IV-10-B in Sewer 1 and II-3-B in Sewer 2), the number of possible cases is  $N^2(N+1)/2 = 12,615$ . Likewise, for a four-way junction not counting the duplicate cases, and without reversal flow in any one of the pipes, the number of possible flow cases is  $N^2(N+1)(N+2)/6 = 130,355$ . When the network size expands from one junction to many junctions, the number of possible cases increases astronomically. This demonstrates the difficulty in solving precisely the storm runoff in sewer networks and illustrates a major difference in considering a single pipe and a sewer system. Obviously, it is not possible to account for all the cases in any attempt of using Eqs. 3.1 and 3.3 (or 3.4 and 3.5), 3.6 and 3.7 or 3.8, and 3.17 through 3.24, whenever applicable, to solve for the stormwater flow in a sewer network. Therefore, assumptions and simplifications are necessary to exclude the less important cases so that the problem becomes manageable and solvable.

#### IV. KINEMATIC WAVE - SURCHARGE MODEL

##### 4.1. Kinematic Wave Approximation

Because of the complexity in solving the Saint Venant equations for unsteady open-channel flows, a number of approximations have been used in solving engineering problems (Yen, 1977). A popular simplification is the kinematic wave approximation which has a simplified momentum equation obtained by dropping all but the last two slope terms in Eq. 3.3 or 3.5, i.e.,

$$S_o = S_f \quad (4.1)$$

The friction slope,  $S_f$ , is normally approximated by the Darcy-Weisbach formula (Eq. 3.10) or Manning's formula (Eq. 3.9). The kinematic wave approximation involves solving Eq. 4.1 with appropriate initial and boundary conditions, together with a continuity equation

$$\frac{\partial A}{\partial t} + \frac{\partial Q}{\partial x} = 0 \quad (3.1)$$

in which the terms are as defined previously in Chapter 3. This equation can be integrated over a reach of the sewer pipe having a length  $\Delta L$  to yield

$$I - Q = \frac{ds}{dt} \quad (4.2)$$

in which  $I$  and  $Q$  are the inflow into and outflow from the reach, respectively;  $s$  is the water storage in the reach, and  $ds/dt$  is the time rate of change of storage. This equation is generally known as the storage equation in hydrology.

The simplified flow equations for a surcharged pipe flow corresponding to the open-channel kinematic wave equations can be obtained from Eq. 3.8 by

neglecting the  $\partial V/\partial t$  term. With the downstream junction water surface,  $H_d$ , related to  $H_{\text{exit}}$  by Eq. 3.21 (Fig. 3.8), Eq. 3.8 yields

$$H_u - K_u \frac{V^2}{2g} - S_f L = H_d + K_d \frac{V^2}{2g} \quad (4.3)$$

together with the pipe flow continuity equation

$$Q = A_f V \quad (3.6)$$

All the terms have been defined previously. The junction continuity equation is given by Eq. 3.18. Combining Eqs. 4.3 and 3.6 and noting that  $A_f = \pi D^2/4$  where  $D$  is the pipe diameter, one obtains

$$K^2 Q^2 = H_u - H_d \quad (4.4)$$

in which

$$K^2 = (K_u + K_d + \frac{5.72gn^2L}{D^{4/3}}) \frac{8}{g\pi^2 D^4} \quad (4.5a)$$

or

$$K^2 = (K_u + K_d + \frac{fL}{D}) \frac{8}{g\pi^2 D^4} \quad (4.5b)$$

Only for special simple cases that an analytical solution can be obtained for the open-channel flow kinematic wave equations. (Eqs. 3.1 or 3.4 and 4.1). In general these equations are solved numerically. In this chapter a simplified kinematic wave-surge model called SURKNET is formulated to simulate approximately the open-channel and surge flows in a sewer network. A more sophisticated and accurate model based on the dynamic wave equations will be presented in a separate report which is the junior author's M.S. thesis.

## 4.2. Formulation of SURKNET Model

The SURKNET Model is formulated based on Eqs. 4.1 and 4.2 for open channel flow and Eqs. 4.3 and 3.6 for surcharged pipe flow, together with Manning's formula (Eq. 3.9 or 3.15) to estimate the friction slope. Details are described as follows.

### 4.2.1. Open-Channel Flow

Instead of solving the kinematic wave equations directly as in a true kinematic wave model (Yen, 1977), Eq. 4.2 is rewritten in a finite difference form for a reach,

$$\frac{I_1 + I_2}{2} - \frac{Q_1 + Q_2}{2} = \frac{s_2 - s_1}{\Delta t} \quad (4.6)$$

in which the subscripts 1 and 2 represent the times  $t_1$  and  $t_2 = t_1 + \Delta t$ . In this equation, all the quantities at time  $t_1$  are known from the results of the previous time-step computation or initial condition. The inflow  $I_2$  is known from the outflow of the preceding reach or manhole. The two unknowns are  $Q_2$  and  $s_2$ . To estimate the storage  $s$ , an approximation proposed by Tholin and Keifer (1960) based on spatial integration of Manning's formula is adopted and modified for part-full pipe flow,

$$s = 0.143 n^{3/5} S_o^{-3/10} \Delta L (\phi d)^{2/5} (I^{3/5} + 5Q^{3/5}) \quad (4.7)$$

Equations 4.6 and 4.7 are solved numerically as follows.

- (A) Select a trial value of  $Q_2$  and compute  $s_2$  from Eq. 4.7.
- (B) Substitute the trial  $Q_2$  and corresponding  $s_2$  into Eq. 4.6.
- (C) Adjust trial value of  $Q_2$ .
- (D) Repeat steps A, B, and C until convergence.

At the entrance of a sewer pipe from the manhole, the inflow,  $I$ , into the first reach of the pipe is computed by using Manning's formula for

part full flow, Eq. 3.15, where the central angle  $\phi$  is a function of the flow depth and pipe diameter as expressed in Eq. 3.14.

The change of water depth in a manhole is computed from the continuity equation (Eq. 3.17) written in a finite difference form,

$$\frac{\Sigma I_1 + \Sigma I_2}{2} - \frac{Q_1 + Q_2}{2} = A_j \frac{H_2 - H_1}{\Delta t} \quad (4.8)$$

in which  $\Sigma$  indicates summation of all the inflows into the manhole and other terms are as defined previously.

#### 4.2.2. Surcharged Flow

Under surcharged condition, the manhole continuity equation (Eq. 3.17) in finite difference form is

$$\frac{\Sigma I_1 + \Sigma I_2}{2} - \frac{Q_1 + Q_2}{2} = \frac{A_2 H_2 - A_1 H_1}{\Delta t} \quad (4.9)$$

in which the manhole cross section area at times  $t_2$  and  $t_1$  may be different when it is completely filled. Considering a sewer pipe together with its upstream manhole as an element, eliminating  $H_{u2}$  by combining Eqs. 4.4 and 4.9 yields

$$K^2 Q_2^2 + \frac{\Delta t}{2A_2} Q_2 - \left[ \frac{\Delta t}{2A_2} (\Sigma I_1 + \Sigma I_2 - Q_1) + \frac{A_1}{A_2} H_{u1} - H_{d2} \right] = 0 \quad (4.10)$$

in which  $H_{u1}$  is the water surface elevation in the upstream manhole at the time  $t_1$ ,  $H_{d2}$  is the water surface elevation in the downstream manhole at the time  $t_2$ , and  $A_1$  and  $A_2$  are the upstream manhole cross sectional areas at  $t_1$  and  $t_2$ , respectively.

Through the  $H_{d2}$  term, this equation clearly indicates that the flows in the surcharged pipes are interrelated and should be considered as a system.

However, for the present model, in order to make the pipe computation sequence compatible with the kinematic model, namely solving the pipes in a cascading manner, pipe by pipe, from upstream towards downstream, it was decided that an approximation is assumed on  $H_{d2}$  so that each pipe can be solved independently. A further reason is that SURKNET is only an approximate model and a more sophisticated dynamic wave is also being developed and will be reported soon. The assumption adopted is that  $H_{d2}$  in Eq. 4.10 is approximated by the depth at the previous time,  $H_{d1}$ . The consequence of this assumption may be severe under unfavorable conditions.

When the water surface in a manhole reaches the ground, surface ponding is assumed without volume limitation. The impounded water on the surface is assumed to return to the same manhole at a later time without any losses. No inter-manhole surface flow is directly allowed.

With the assumptions just described, Eq. 4.10 can easily be solved as a quadratic function of  $Q_2$ . But violations of the assumptions introduce complications into the method. The following describes the possible consequences of the above formulation.

1. The assumptions are satisfied and the algorithm converges to a correct value within a finite number of iterations. No problems arise, and the routing is complete for that element at the current time.

2. The assumptions are not satisfied and the required discharge  $Q_2$  is so large that it drains more water than that stored in the upstream manhole. This would indicate a dry bed situation in that element which is not allowed. Hence, the discharge,  $Q_2$ , is set to the base flow value, and the routing is complete.

3. The assumptions are not satisfied, and the required discharge  $Q_2$  is not large enough to drain away a sufficient amount of storage within the

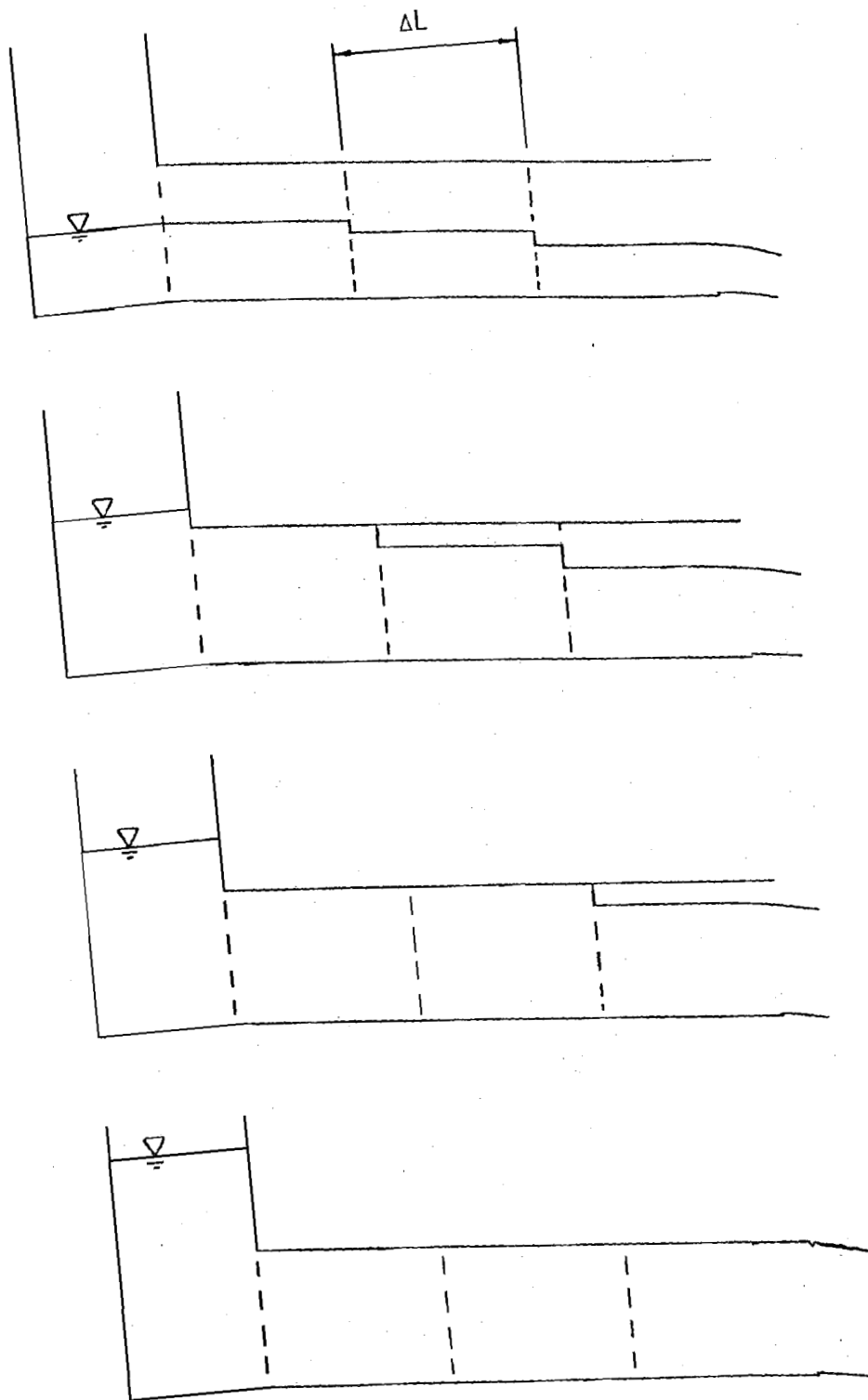

Fig. 4.1. Example of Propagation of Flow Transition



specified time interval. In this case, the computed  $Q_2$  is accepted as the surcharged element discharge and the upstream manhole depth and storage values are set to the values consistent with  $Q_2$ .

The reader should be aware that the impetus for making the above simplifying assumption is the nature of the kinematic wave routing scheme. Since the downstream boundary condition is not accounted for in the analysis, the downstream manhole water depth at the new time is not known. Therefore, some reasonable assumption must be made to carry out the surcharged flow computations. Higher order schemes such as the diffusion wave or dynamic wave do not exhibit this problem.

#### 4.2.3. Flow Transition

Flow transition, as defined in this study, is the dynamic process whereby the flow condition in a given pipe reverts between open-channel and surcharged flow. For a sufficiently heavy rainfall event, the flow will initially be open-channel, then make the transition to surcharged flow. As the storm passes, the pressurized condition is relieved and the transition back to open-channel flow is made. The transition problem is a function of channel geometry, slope, roughness, length, surface tension, roll waves, and the degree of air entrainment. In the transition computation, often both the hydrodynamic and numerical instabilities are involved. In the SURKNET formulation, the instability effects of rollwaves, surface tension, and air entrainment are neglected.

In a sewer consisting of a number of reaches, transition is assumed to propagate towards either upstream or downstream reach by reach in succession (e.g., Fig. 4.1). However, if a long computational time interval is used, the transition may occur simultaneously in more than one reach. During the

transition propagation, surcharged reaches are assumed to carry the just-full pipe discharge until transition is completed for the entire sewer.

Transition between open-channel flow and surcharge flow is assumed to follow the trajectory JFE of the discharge rating curve shown in Fig. 3.5, adjusted for flow unsteadiness, instead of JGFE. However, to avoid repeated computations of the rating curves for different degrees of unsteadiness, it is arbitrarily assumed that the transition point J occurs at the flow depth to pipe diameter ratio,  $h/D$ , equal to 0.91. The same assumption was made in the French model CAREDAS mentioned in Chapter II. A better assumption would be to assume the transition from open-channel flow to surcharged flow to follow JGE and from surcharged flow to open-channel flow to follow EFJ. However, because of the loop nature of JGEFJ for the rising and falling discharges, a computational stability problem may occur if the discharge changes slowly near this transition region. Therefore, the simple version is assumed in SURKNET.

For the case of downstream propagation of the transition, when the outflow of a reach approaches the just-full pipe discharge, transition is assumed to occur in that particular reach.

For the case of upstream propagation of transition to surcharge, when surcharge occurs at the upstream end of a reach, the immediate upstream reach is checked for transition. If the upstream reach is not already surcharged or undergoing transition for surcharging, this upstream reach is assumed to be surcharged during one time increment of computation. If the flow in the upstream reach is originally supercritical, this moving transition is essentially a simplified view of a upstream-moving hydraulic jump.

For the upstream propagation of transition from surcharged flow to open-channel flow, instead of considering the transition reach by reach, an assumption is made that when the water surface at the exit of the sewer drops

below the pipe crown, the exit is no longer submerged and the entire sewer will become open-channel flow in one time increment. This assumption is necessary because the kinematic wave approximation is unable to account for the downstream backwater effect.

#### 4.2.4. Boundary Conditions

In SURKNET the sewer network is divided into elements. Each element consists of a sewer together with the manhole connected to its upstream. For surcharged condition, the element is analyzed as a unit by solving Eq. 4.10. For open-channel and transition conditions, the flow is solved separately for the manhole and reaches of sewers using the appropriate equations given in Section 4.2.1. The solution depends on the boundary conditions, i.e., the flow conditions imposed at the ends of the manholes or sewers. The inherent assumptions of the kinematic approximation preclude the consideration of the downstream boundary effects. However, in SURKNET an attempt is made to account for downstream backwater effect when transition to surcharge is propagating towards upstream as discussed in Section 4.2.3.

The upstream boundary condition for any element is the manhole inflows directly into the manhole from surface and from upstream sewers. The upstream boundary condition of the sewer is the outflow from the manhole. If the sewer is completely surcharged and its upstream end submerged, the element is solved as a unit (Eq. 4.10) and the boundary condition between the manhole and the following sewer is not needed. For transition and open-channel flow in the pipe, the boundary conditions are elaborated as follows.

- (a) The upstream manhole is filled below the crown at the entrance of the following pipe. In this case, the sewer (at least for its entrance reach) is open-channel flow. The upstream manhole water surface elevation is computed by using Eq. 4.8. The initial inflows,

outflow, and water surface elevation of the manhole at the time  $t = t_1$  are all known. The inflows into the manhole at the time  $t_2 = t_1 + \Delta t$  are also known as the boundary condition. The manhole outflow,  $Q_2$ , at the time  $t_2$  is approximated by using Manning's formula for part-full pipe flow, Eq. 3.15, in which  $\phi$  is a known function of the water surface elevation  $H_2$  at the time  $t_2$ . Accordingly,  $H_2$  and  $Q_2$  can be solved and in turn used as the upstream boundary condition for the entrance reach of the open-channel sewer flow. The flow in the sewer reach is determined by solving Eqs. 4.6 and 4.7.

- (b) The manhole is filled above the crown of the following pipe but below the ground surface (Case M in Fig. 3.9). - In this case, the sewer flow can be open-channel (Case III in Fig. 3.1) or surcharged (Case IV in Fig. 3.1). For the latter, the element is surcharged, Eq. 4.10 is applicable and no boundary condition at the entrance of the sewer is required. For the former, the manhole water surface elevation  $H_2$  at time  $t_2$  is given by Eq. 4.8 if  $Q_2$  is provided. Strictly speaking, the discharge into the pipe is a function of the water surface elevation in the upstream manhole as well as the downstream condition. Theoretically,  $Q_2$  can be computed by using a sluice gate formula, equal to the flow cross sectional area  $A$  at the vena contracta multiplied by the velocity given by Eq. 3.19. However, since the time of occurrence of this phase is usually short in comparison to the time increment of the routing, for the sake of simplicity, the manhole outflow is assumed equal to the just-full pipe discharge given by Manning's formula. This manhole outflow is then used as the upstream boundary condition for the following sewer reach.

(c) The manhole is filled and ponding occurs on ground surface (Case N in Fig. 3.9).- The manhole water budget is described by Eq. 4.9 in which H is essentially equal to the ground elevation, but  $A_2 H_2 - A_1 H_1 - \Delta s$  which is the change of water volume on the ground. This volume,  $\Delta s$ , can be computed if  $Q_2$  is known. Again, as described in the preceding paragraph,  $Q_2$  should be evaluated by using the sluice gate equation with the head equal to the difference between the ground elevation and water surface elevation at the vena contracta. Once more for the sake of simplicity, the sewer upstream boundary condition is approximate in SURKNET by the just-full pipe discharge given by Manning's formula.

#### 4.3. SURKNET Computer Program

The SURKNET computer program was written in ASA FORTRAN for running on the University of Illinois CDC CYBER 175 digital computer system. It consists of nearly 1000 statements. A flow chart of the program is shown in Fig. 4.2. Since no user's guide was prepared, the program is not listed in this report. However, a copy of the listing is available at the Hydrosystems Laboratory of the University of Illinois at Urbana for inspection.

#### 4.4. Example Application of SURKNET

The SURKNET model was applied to a hypothetical 5-pipe sewer network as an example. The network properties and the simulation results are presented in this section.

##### 4.4.1. Example Sewer Network

The example sewer network contains five sewers of different lengths, diameters, and slopes as shown in Fig. 4.3 and Tables 4.1. The Manning roughness factor is 0.012 for all the sewers. The manhole properties are given in

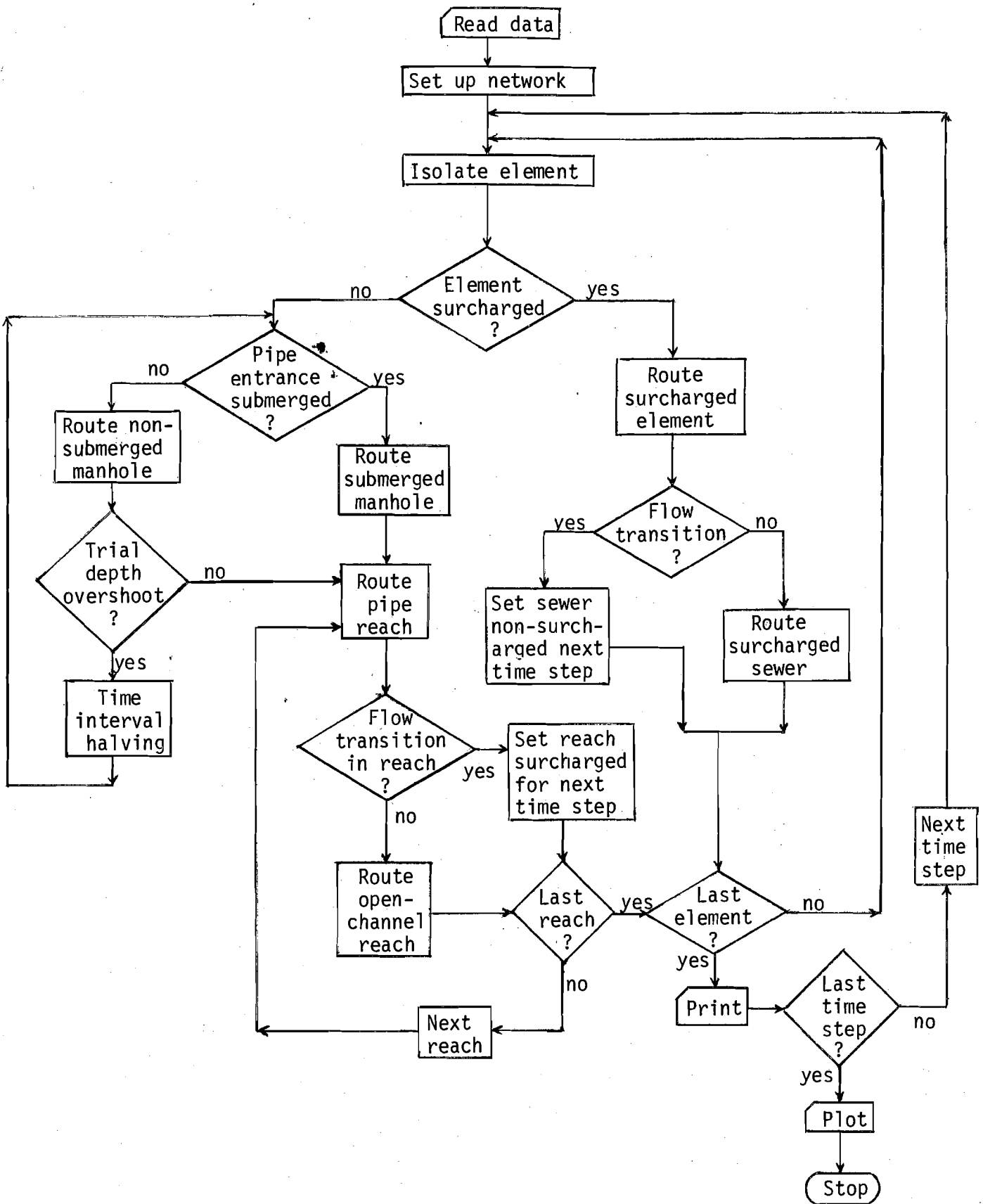

Fig. 4.2. Flow Chart for Computer Program SURKNET

Table 4.2. The sewers are invert-aligned and the inverts are 6 inches above the bottom of the connecting manhole. The pipe invert elevation at the outlet (root node) is located such that the minimum soil cover requirement above the sewer pipe can be satisfied.

In the example, identical inflow hydrographs are applied to each of the five manholes. No direct inflow hydrograph enters the outlet, (Root Node number 6). The values of the hydrograph are listed in Table 4.3.

In the numerical computation, the time interval used is  $\Delta t = 30$  sec and the space interval is  $\Delta L = 100$  ft for all sewers except Sewer 2-3 for which  $\Delta L = 50$  ft.

TABLE 4.1. SEWER PROPERTIES OF EXAMPLE NETWORK

Sewer	Length (ft)	Slope	Diameter (ft)
1-3	400	0.0025	4
2-3	100	0.0030	3
3-5	200	0.0020	5
4-5	300	0.0010	3
5-6	500	0.0015	6

TABLE 4.2. MANHOLE PROPERTIES OF EXAMPLE NETWORK

Manhole	Ground Elevation (ft)	Manhole Depth (ft)	Manhole Diameter (ft)
1	51.10	14.0	4
2	50.40	14.0	3
3	48.10	12.0	5
4	48.00	12.0	3
5	46.70	11.0	6
6 -- Outlet (Root node)			
pipe invert elevation = 35.45 ft.			

#### 4.4.2. Results

The computer simulation results of the example using the SURKNET model are plotted in Figs. 4.4 through 4.8, respectively, for the five sewers. In each of these figures, the discharge plot shows the inflow hydrograph into the upstream manhole and the outflow hydrograph at the exit of the sewer. The storage plots shows the combined in-line storage of water in the sewer and the manhole connected to its upstream end, as well as the surface ponding above ground when the manhole is completely filled.

The manhole inflow hydrographs were purposely selected with a high peak discharge in order to generate severe surcharge in all the sewers. Considering that the SURKNET model was meant only as an approximate simulation of the flow, the results are indeed reasonable and acceptable. The sharp peaks of the outflow hydrographs for Sewers 3-5, 4-5, and 5-6 during the period  $t = 10$  min to 15 min are the combined result of numerical errors and hydraulic assumptions. An anomaly is the early peak of the in-line storage in Fig. 4.8 for Element 5-6. However, because of the computer money and time constraints, further investigation was not made.



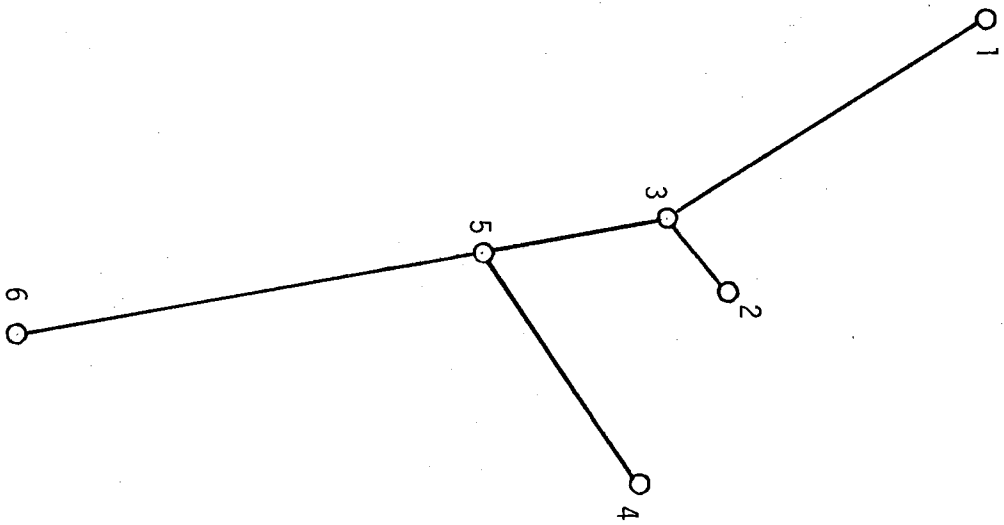

TABLE 4.3. EXAMPLE MANHOLE INFLOW HYDROGRAPH

Time (sec)	Discharge (cfs)
0	1
30	1
60	41
90	81
120	121
150	161
180	201
210	241
240	201
270	161
300	121
330	81
360	41
390	1

Fig. 4.3. Example Sewer Network

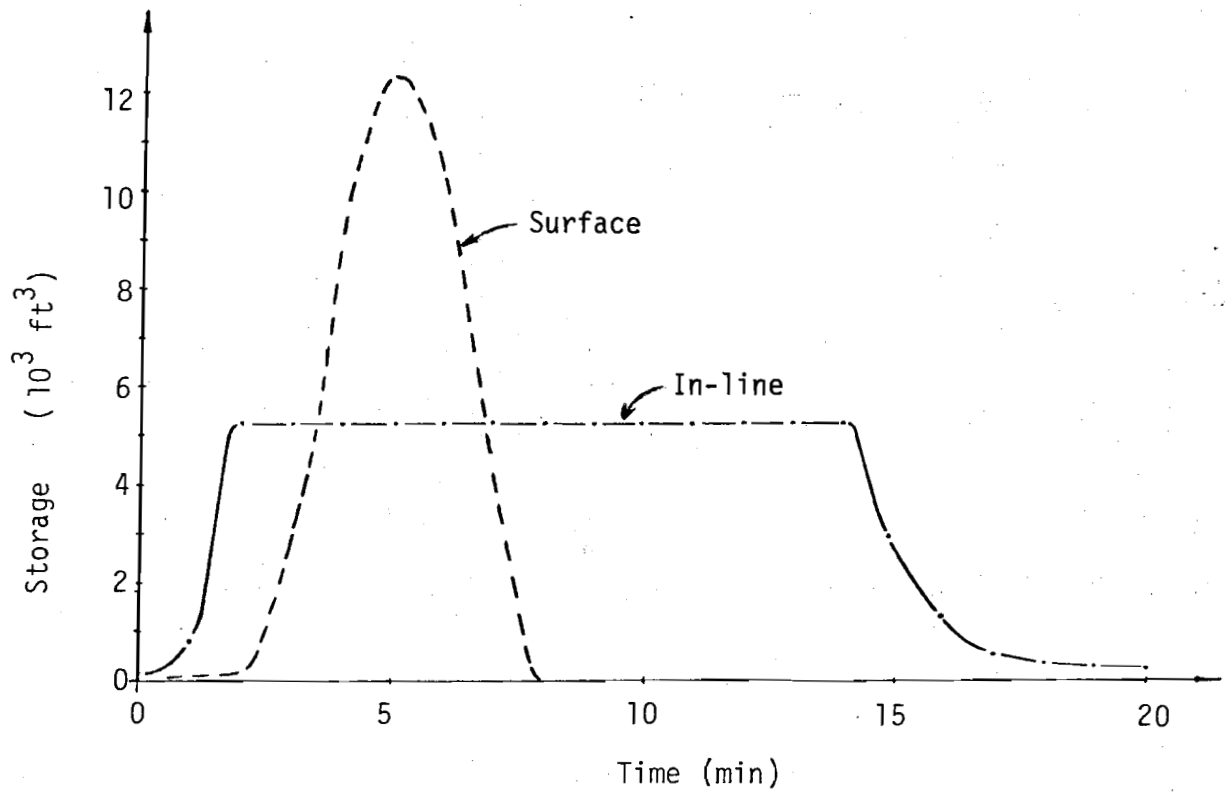
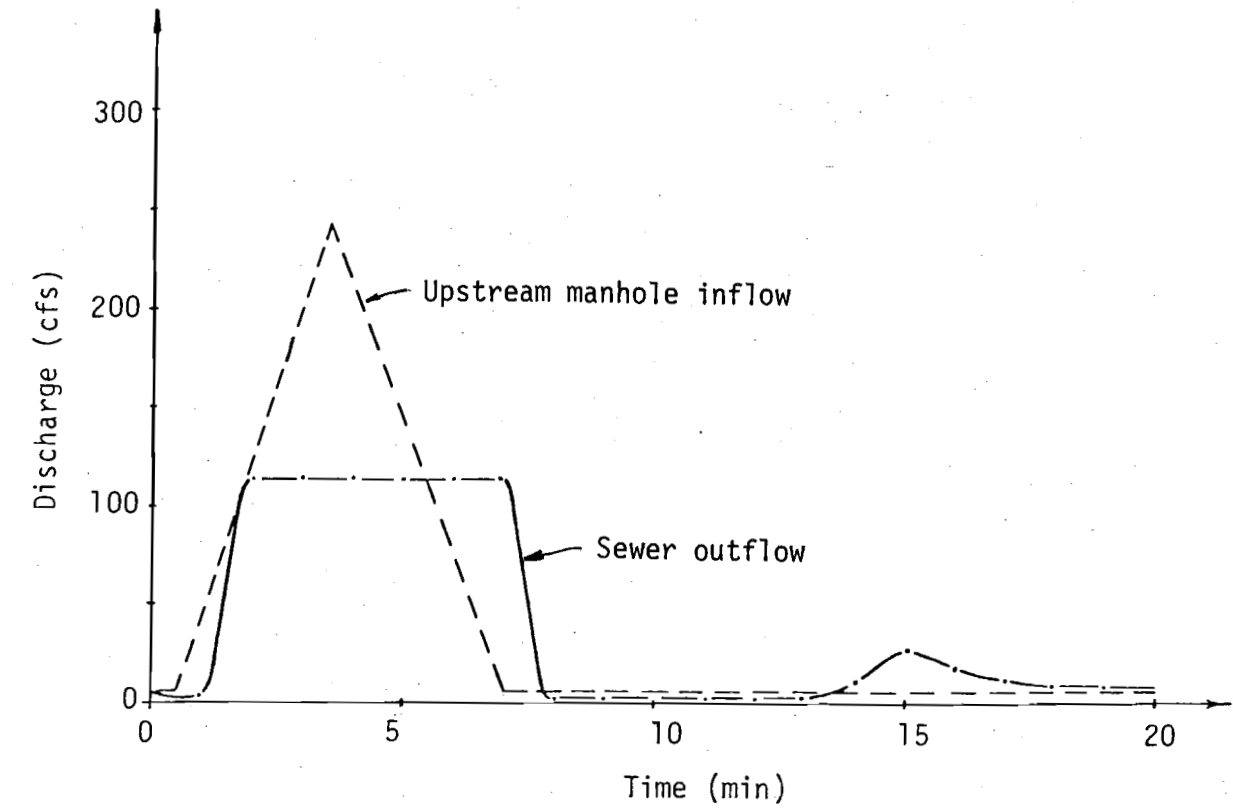

Fig. 4.4. Discharge and Storage Graphs for Element 1-3

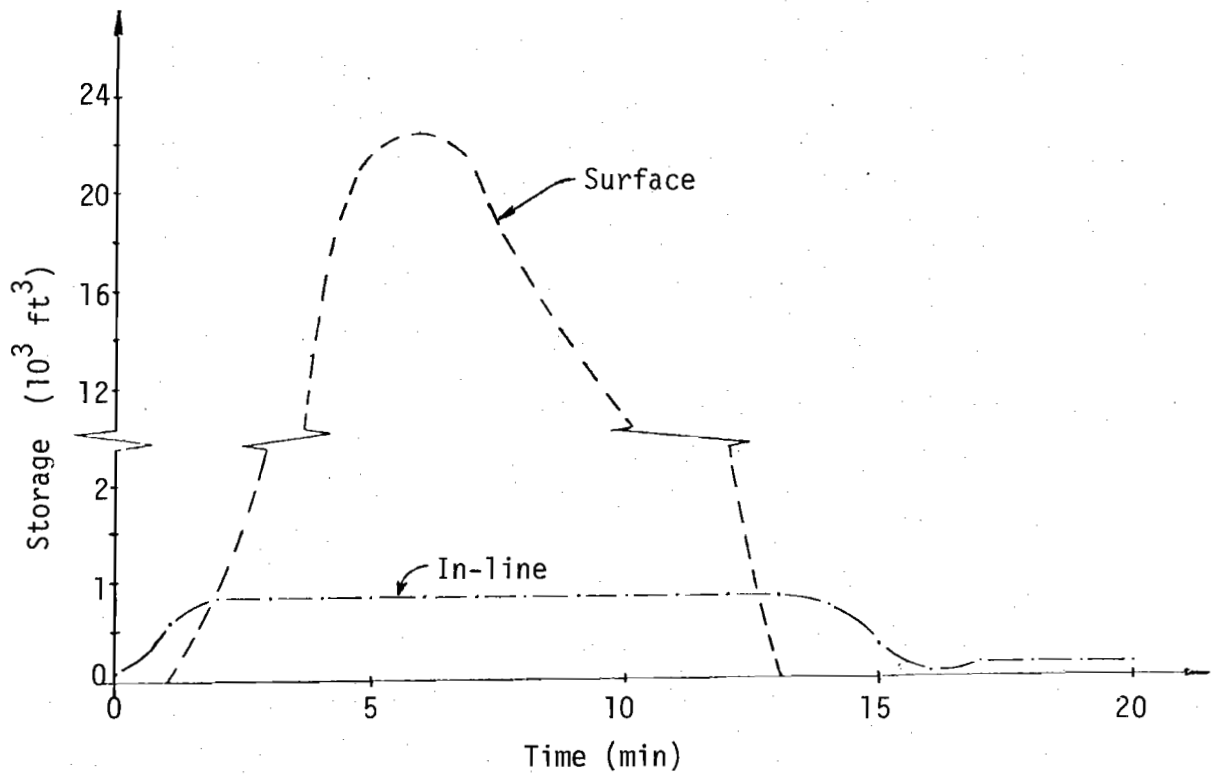
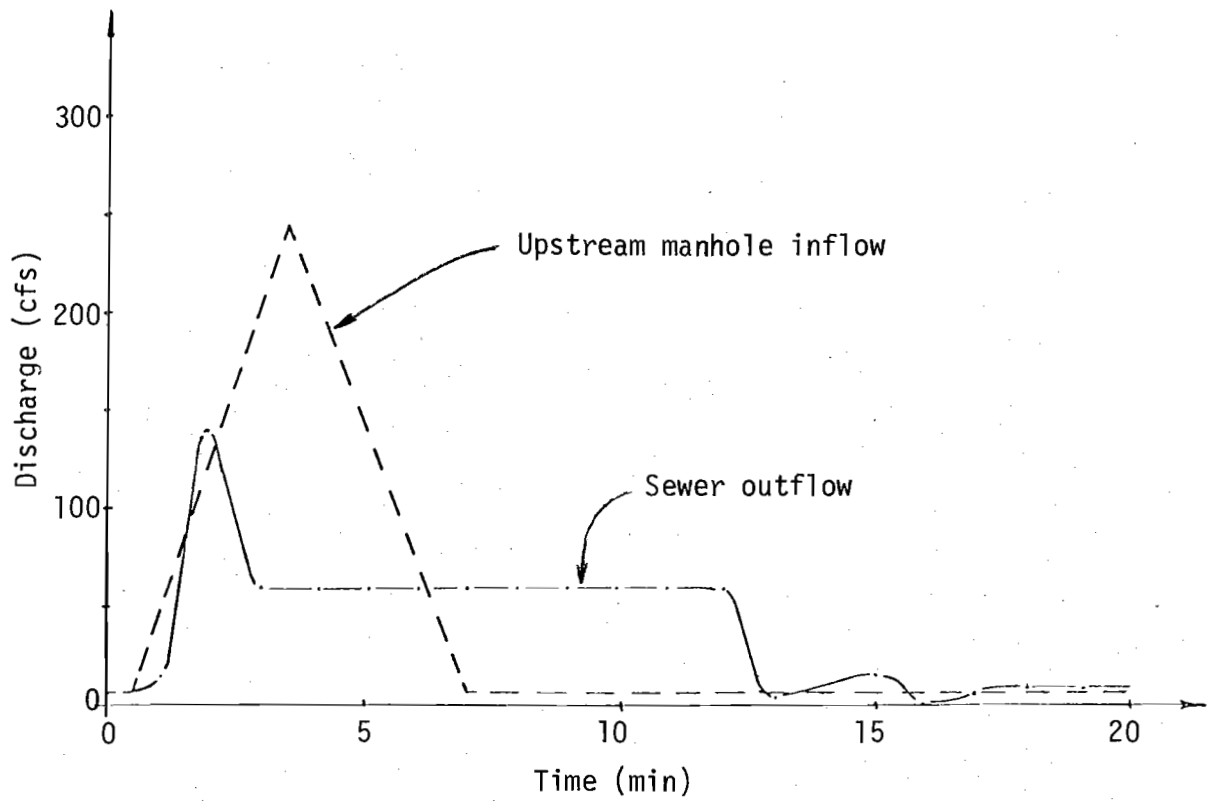

Fig. 4.5. Discharge and Storage Graphs for Element 2-3

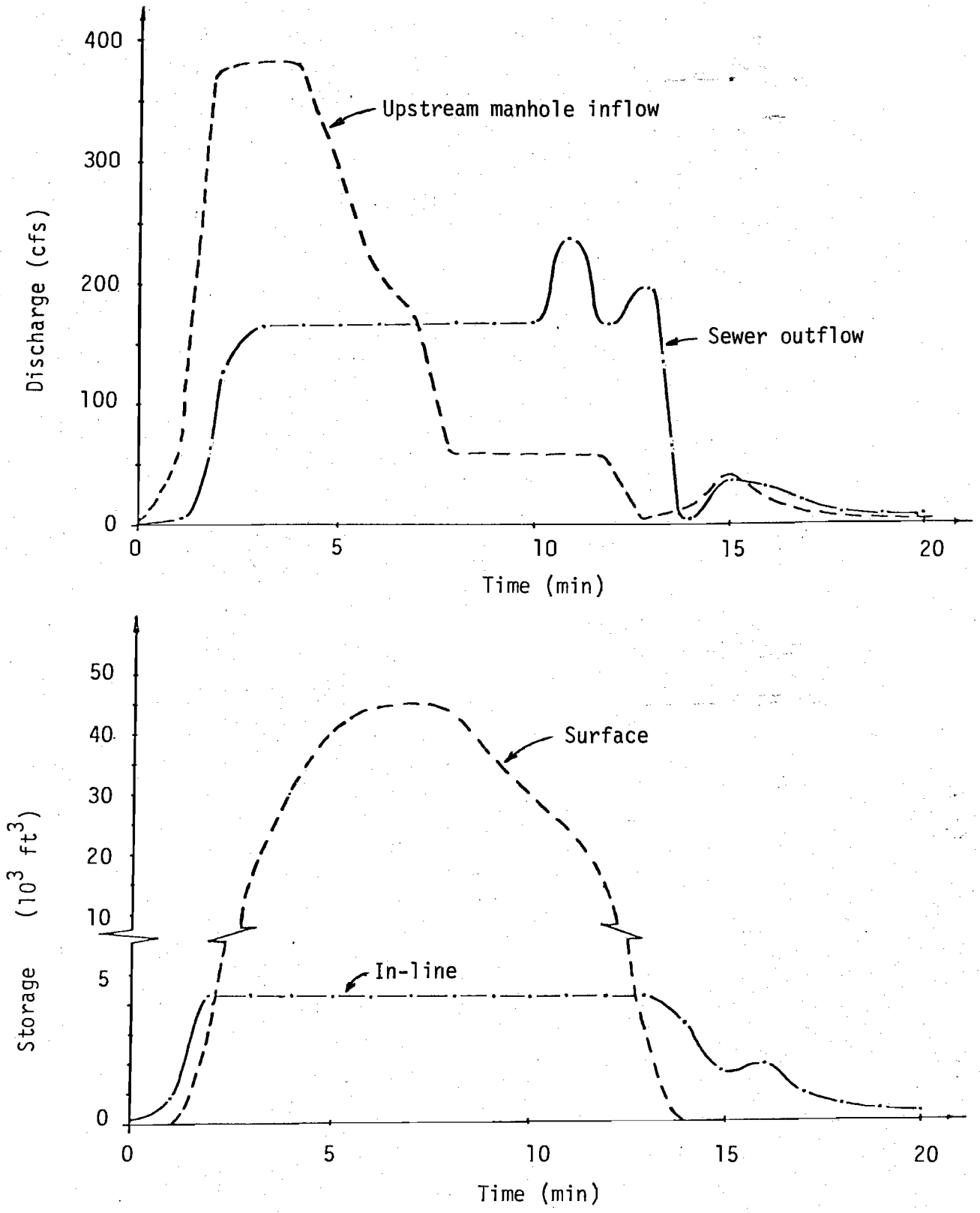

Fig. 4.6. Discharge and Storage Graphs for Element 3-5

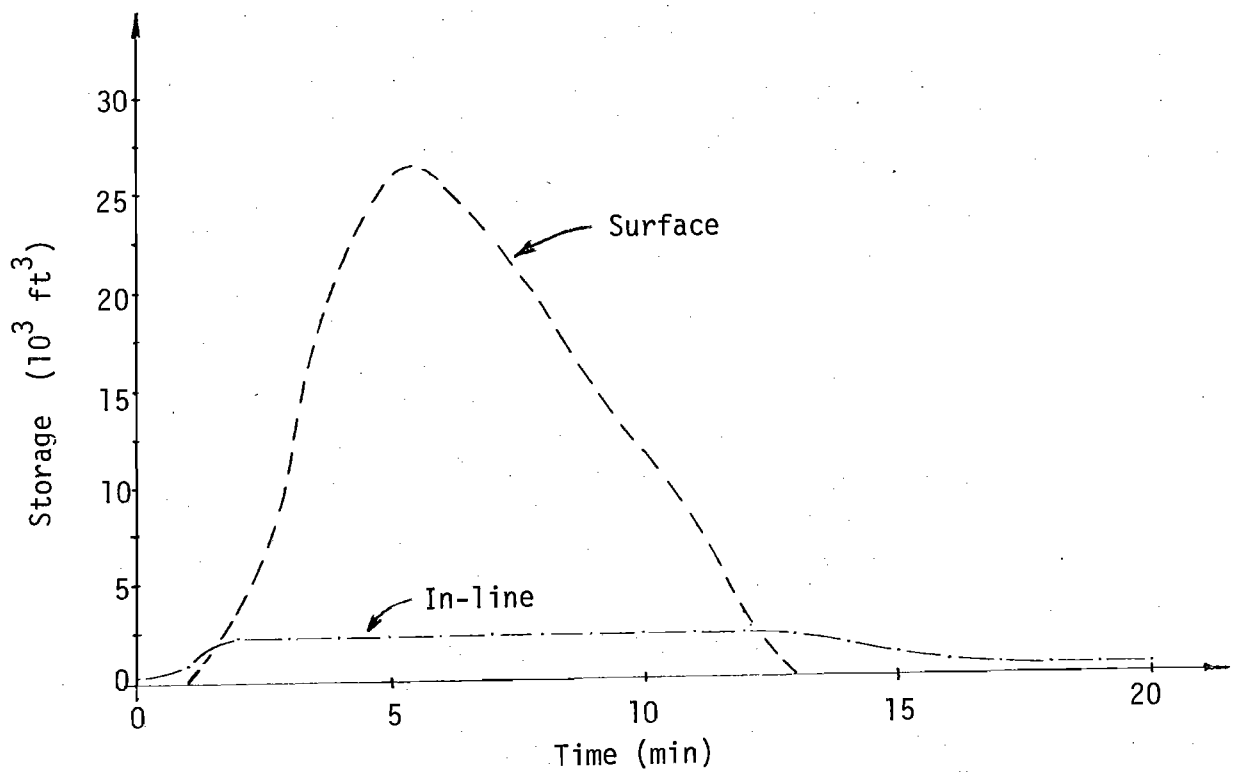
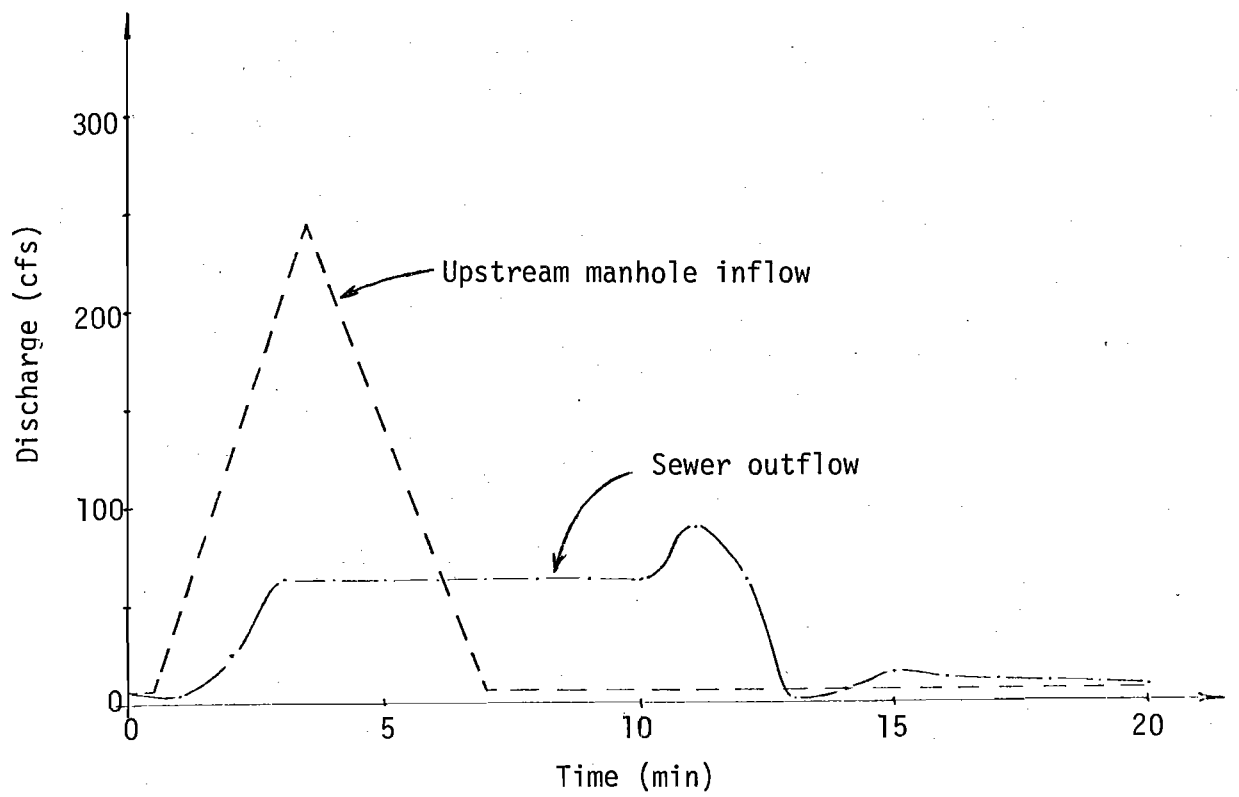

Fig. 4.7. Discharge and Storage Graphs for Element 4-5

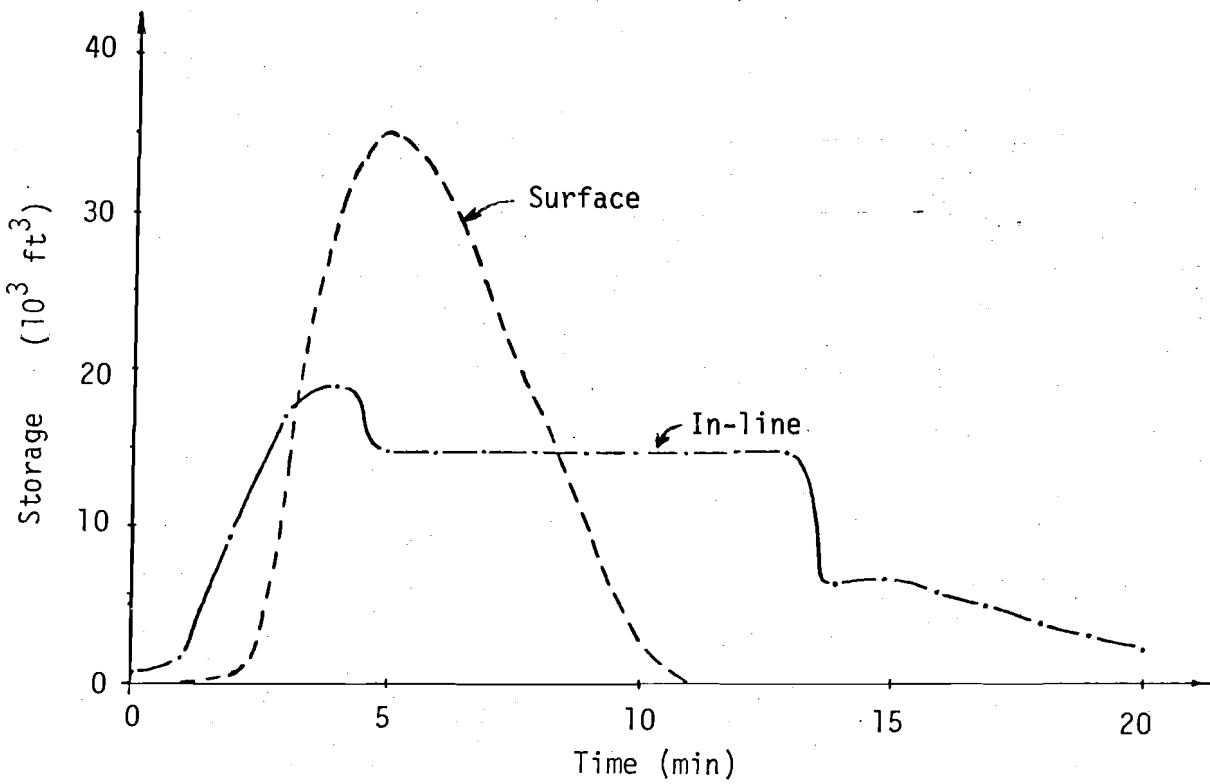
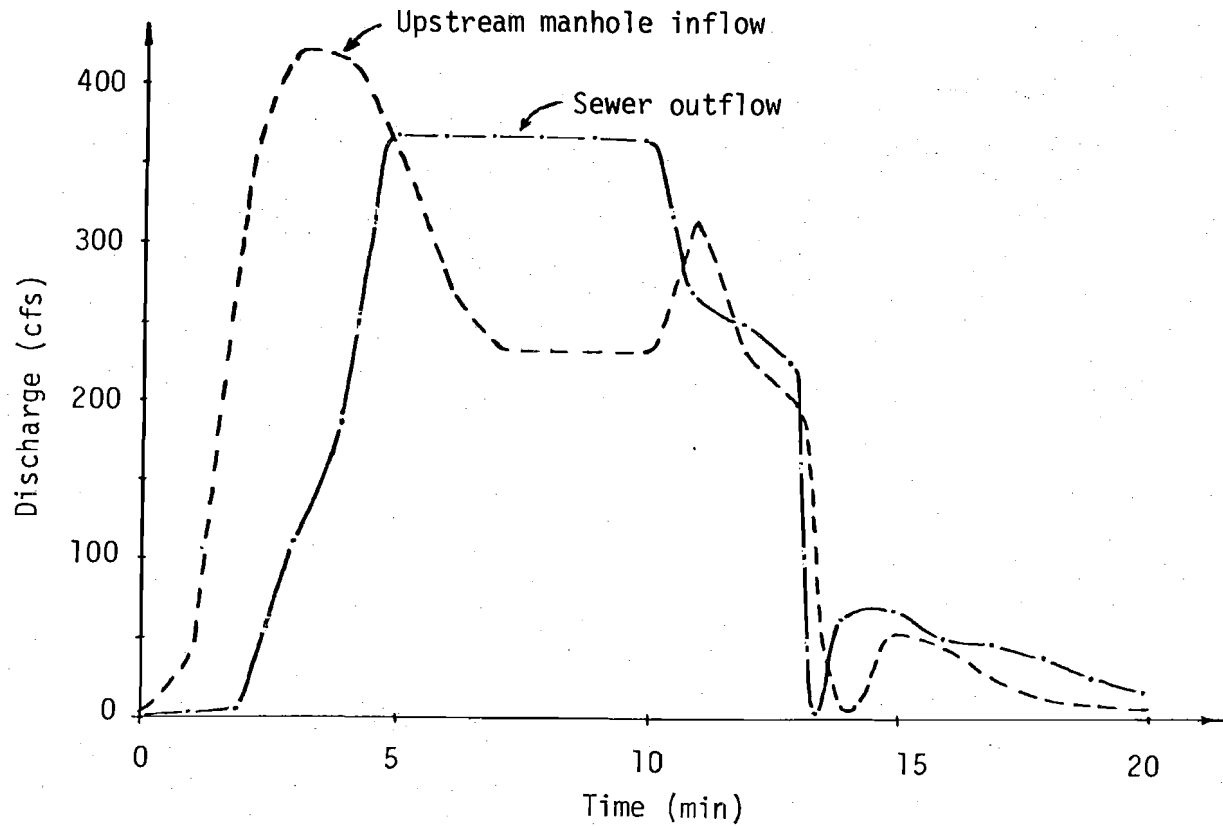

Fig. 4.8. Discharge and Storage Graphs for Element 5-6

## V. CONCLUDING REMARKS

Hydrodynamically, storm sewer flow is one of the most complicated and difficult problems. The basic physical principles of surcharged and open-channel flows are described in Chapter 3. The physical phenomena of the transition between these two flow phases are also discussed. In view of the state-of-art in simulating surcharged sewer flow, an attempt has been made to develop improved models for simulation of such flow. It is shown in this report that a kinematic wave model, SURKNET, can be formulated. Nevertheless, because of the inherent limitation of the kinematic wave approximation, SURKNET can only be considered as a small step forward in the advancement of the techniques in reliable simulation. In a companion report under preparation, a dynamic wave - surcharge model will be proposed. Nevertheless, further research, particularly verification of the models using reliable field data is most desirable.

## REFERENCES

- Adams, R. W., "Distribution Analysis by Electronic Computer," Jour. Institute of Water Engineers, London, Vol. 15, pp. 415-428, Oct. 1961.
- ASCE (American Society of Civil Engineers), and Water Pollution Control Federation, "Design and Construction of Sanitary and Storm Sewers," ASCE Manuals and Reports on Engineering Practice No. 37., New York, 1969.
- Bettess, R., Pitfield, R. A., and Price, R. K., "A Surcharging Model for Storm Sewer Systems," Urban Storm Drainage, Proceedings of the First International Conference on Urban Storm Drainage, Ed. by P. R. Helliwell, pp. 306-316, Wiley - Interscience, New York, 1978.
- Bodhaine, G. L., "Measurement of Peak Discharge at Culverts by Indirect Methods," Techniques of Water-Resources Investigations of USGS, Book 3, Chapter 3, U.S. Geological Survey, p. 60, 1968.
- Brandstetter, A., "Assessment of Mathematical Models for Urban Storm and Combined Sewer Management," Environmental Protection Technology Series EPA-600/2-76-175a, Municipal Environmental Research Laboratory, US EPA, Aug. 1976.
- Chow, V. T., Open-Channel Hydraulics, McGraw-Hill Book Co., New York, pp. 493-499, 1959.
- Chow, V. T., and Yen, B. C., "Urban Stormwater Runoff - Determination of Volumes and Flowrates," Environmental Protection Technology Series EPA-600/2-76-116, Municipal Environmental Research Laboratory, US EPA, (available as PB 252 410 from NTIS Springfield, VA), May 1976.
- Colyer, P. J., and Pethick, R. W., "Storm Drainage Design Methods: A Literature Review," Report No. INT 154, Hydraulics Research Station, Wallingford, England, March 1976.
- Cross, H., "Analysis of Flow in Networks of Conduits or Conductors," Bulletin No. 286, Engineering Experiment Station, Univ. of Illinois, Urbana, IL 32 p., Nov. 1936.
- Dillingham, J. H., "Computer Analysis of Water Distribution Systems, Part II," Water and Sewage Works, Vol. 114, pp. 43-45, Apr. 1967.
- Dukler, A. E., "Characterization, Effects, and Modeling of the Wavy Gas-Liquid Interface," Progress in Heat and Mass Transfer, Vol. 6, pp. 207-234, 1972.
- Epp, R., and Fowler, A. G., "Efficient Code for Steady-State Flows in Networks," Jour. Hydraulics Div., ASCE, Vol. 96, No. HYL, pp. 43-56, Jan. 1970.
- Fietz, T. R., "Improved Head-Discharge Relations for Pipe Network Analysis by the Loop Method," Jour. Hydraulic Research, Vol 11, No. 2, pp. 123-136, 1973.



- Graves, Q. B., and Branscome, D., "Digital Computers for Pipeline Network Analysis," Jour. Sanitary Eng. Div., ASCE, Vol. 84, No. SA2, pp. 1608-1618, April 1958.
- Haindl, K., "Hydraulic Jump in Closed Conduits," Proceedings, 7th Congress, IAHR, Vol.2, pp. D32.1-D32.12, Lisbon, 1957.
- Hoag, L. N., and Weinberg, G., "Pipeline Network Analysis by Electronic Digital Computer," Jour. Am. Water Works Assoc., Vol. 49, pp. 517-524, 1957.
- Jacoby, S.L.S., and Twigg, D. W., "Computer Solutions to Distribution Network Problems," Boeing Research Report, Renton, Washington, 1968.
- James F. MacLaren, Ltd., "Review of Canadian Design Practice and Comparison of Urban Hydrologic Models," Research Report No. 26, Canada - Ontario Agreement Research Program for the Abatement of Municipal Pollution, Canadian Center for Inland Waters, Burlington, Ont., Oct. 1975.
- Jeppson, R. W., Analysis of Flow in Pipe Networks, Ann Arbor Science, Ann Arbor, Mich., pp. 71-150, 1975.
- Killen, J. M., and Anderson, A. G., "A Study of the Air-Water Interface in Air-Entrained Flow in Open-Channels," Proc. 13th Congress IAHR, Vol. 2, pp. 339-347, Kyoto, Japan, 1969.
- Lekane, Th., "A Model for Calculating Steady-State Flow in a Water Network," Jour. Hydraulic Research, Vol. 17, No. 2, pp. 149-163, 1979.
- Lemieux, P. F., "Efficient Algorithm for Distribution Networks," Jour. Hydraulics Div., ASCE, Vol. 98, No. HY11, pp. 1911-1920, Nov. 1972.
- Marlow, T. A., Hardison, R. L., Jacobson, H., and Biggs, G. E., "Improved Design of Fluid Networks with Computers," Jour. Hydraulics Div., ASCE, Vol. 92, No. HY4, pp. 43-61, July 1966.
- Martin, D. W., and Peters, G., "The Application of Newton's Method to Network Analysis by Digital computer," Jour. Institute of Water Engineers, London, Vol. 17, pp. 115-129, 1963.
- Mayer-Peter, E., and Favre, H., "Über die Eigenschaften von Schwälten und die Berechnung von Unterwasserstollen," (On the surge characteristics and the Design of Under-water Conduit), Schweizerische Bauzeitung, Zurich, Vol. 100, No. 4-5, pp. 43-50 and 61-66, July 1932.
- Metcalf & Eddy, Inc., University of Florida, and Water Resources Engineers, Inc., "Storm Water Management Model," Vol. 1-4, Water Pollution Control Research Series 11024 DOC, US EPA, 1971.
- Miller, D. S., "Internal Flow: A Guide to Losses in Pipes and Duct Systems," British Hydromechanics Research Association, Cranfield, England, 1971.

- Portland Cement Association, Handbook of Concrete Culvert Pipe Hydraulics, PCA, Skokie, IL, 1964.
- Preissmann, M. A., and Cunge, J. A., "Calculation of Wave Propagation on Electronic Machines," Proceedings, 9th Congress, IAHR, Dubrovnik, pp. 656-664, 1961.
- Rouse, H., (Ed.) Engineering Hydraulics, John Wiley & Sons, Inc., New York, P. 414, 1950.
- Sangster, W. M., Wood, H. W., Smerdon, E. T., and Bossy, H. G., "Pressure Changes at Sewer Drainage Junctions," Eng. Bull. No. 41, University of Missouri, Columbia, MO, 1958.
- Sevuk, A. S., and Yen, B. C., "Comparison of Four Approaches in Routing Flood Wave Through Junction," Proceedings, 15th Congress, IAHR, Vol. 5, pp. 169-172, 1973.
- Sevuk, A. S., Yen, B. C., and Peterson, G. E., II., "Illinois Storm Sewer System Simulation Model: User's Manual," Research Report No. 73, Water Resources Center, University of Illinois, Urbana, IL, (available as PB 227 338 from NTIS, Springfield, VA), Oct. 1973.
- Shamir, U., "Water Distribution Systems Analysis," Report RC 4389, IBM Watson Research Center, Yorktown Heights, NY, June 1973.
- Shamir, U., and Howard, C.D.D., "Water Distribution Systems Analysis," Jour. Hydraulics Div. ASCE, Vol. 94, No. HY1, pp. 219-234, Jan 1968.
- Shubinski, R. P., and Roesner, L. A., "Linked Process Routing Models," paper presented at Am. Geophy. Union annual spring meeting, Washington, D.C., April 1973.
- Song, C.C.S., "Two-Phase Flow Hydraulic Transient Model for Storm Sewer Systems," Proceedings, 2nd Internat. Pressure Surge, BHAR Fluid Engineering, Bedford, England, pp. C2.17-C2.34, 1976.
- Song, C.C.S., "Verification of Transient Mixed-Flow Model," Verification of Mathematical and Physical Models in Hydraulic Engineering, Proceedings, 26th Hydraulics Div. Specialty Conf., Maryland, ASCE, New York, pp. 690-701, 1978.
- Stoner, M. A., "Analysis and Control of Unsteady Flows in Natural Gas Piping Systems," Ph.D. Thesis, Dept. of Civil Eng., University of Michigan, 1968.
- Terstriep, M. L., and Stall, J. B., "The Illinois Urban Drainage Area Simulator, ILLUDAS," Bulletin 58, Illinois State Water Survey, Champaign, IL, 1974.
- Tholin, A. L., and Keifer, C. J., "Hydrology of Urban Runoff," Transactions, ASCE, Vol. 125, pp. 1308-1379, 1960.
- Townsend, R. D., and Prins, J. R., "Performance of Model Storm Sewer Junctions," Jour. Hydraulics Div., ASCE, Vol. 104, No. HY1, pp. 99-104, Jan. 1978.

- Transport and Road Research Laboratory, "A Guide for Engineers to the Design of Storm Sewer Systems," Road Note 35, 2nd ed., TRRL, Dept. of the Environment, U.K., 1976.
- Vardy, A. E., "On the Use of the Method of Characteristics for the Solution of Unsteady Flows in Networks," Proceedings, 2nd Internat. Conf. Pressure Surge, BHRA Fluid Engineering, Bedford, England, pp. H2.15-H2.30, 1976.
- Volkart, P., "Hydraulische Bemessung steiler Kanalisationsleitungen unter Berücksichtigung der Luftaufahme" (Partially Filled Steep Pipe Flow under Air Entrainment), Report No. 30, Institute of Hydraulic Engineering, Hydrology, and Glaciology, Technical University of Zurich, Switzerland, 1978.
- Wiggert, D. C., "Transient Flow in Free-Surface, Pressurized Systems," Jour. Hydraulics Div. ASCE, Vol. 98, No. HY1, pp. 11-27, Jan. 1972.
- Wood, D. J., and Charles, C.O.A., "Hydraulic Network Analysis Using Linear Theory," Jour. Hydraulics Div., ASCE, Vol. 98, No. HY7, pp. 1157-1170, July 1972.
- Wylie, E. B., and Streeter, V. L., Fluid Transients, McGraw-Hill, Inc., New York, pp. 191-199, 1978.
- Wylie, E. B., Streeter, V. L., and Stoner, M. A., "Unsteady Natural Gas Calculations in Complex Piping Systems," Soc. Petroleum Engrs. Jour., Vol. 14, No. 1, pp. 35-43, Feb. 1974.
- Yen, B. C., "Open-Channel Flow Equations Revisted," Jour. Eng. Mech. Div., ASCE, Vol. 99, No. EM5, pp. 979-1009, Oct. 1973.
- Yen, B. C., "Further Study on Open-Channel Flow Equations," Sonderforschungs - bereich 80 Report, No. SFB80/T/49, University of Karlsruhe, West Germany, April 1975.
- Yen, B. C., "Hydraulics of Storm Sewer Design," Proceedings, Internat. Symp. on Urban Hydrology, Hydraulics and Sediment Control, Lexington, Kentucky, pp. 345-362, July 1977.
- Yen, B. C., "Hydraulic Instabilities of Storm Sewer Flows," Urban Storm Drainage, Proceedings of the First International Conference on Urban Storm Drainage, Ed. by P. R. Helliwell, pp. 282-293, Wiley-Interscience, New York, 1978a.
- Yen, B. C., (Ed.), Storm Sewer System Design, University of Illinois, Urbana, IL., 282 p., 1978b.
- Zovne, J. J., "The Numerical Solution of Transient Supercritical Flow by the Method of Characteristics with a Technique for Simulating Bore Propagation," Ph.D. dissertation, School of Civil Engineering, Georgia Inst. Tech., Atlanta, GA, 1970.