



# NEST HOUSES FOR WOOD DUCKS

ILLINOIS DEPARTMENT OF CONSERVATION, SPRINGFIELD  
AND  
ILLINOIS NATURAL HISTORY SURVEY, URBANA

WOOD DUCKS readily accept nest houses that are properly made and placed. Nest houses designed to eliminate some of the nest predation have the potential of providing safer nest sites than do natural cavities. In Illinois, studies have shown that only 37 percent of the wood duck nests in natural cavities were successful, whereas 71 percent of the nests in metal houses were successful. Raccoons are responsible for the greatest destruction of wood duck nests.

Two basic types of materials, wood and metal, are suitable for wood duck houses. A house made from either material has certain advantages or disadvantages over the other. The wood house is more readily accepted by wood ducks, but the metal house provides the safer nest site.

Next to raccoons, fox squirrels are the greatest cause of wood duck nest destruction in Illinois. It is difficult to prevent fox squirrels from entering wood nest houses, but nests in metal houses are practically immune to their depredations. Where fox squirrels pose no problem, wood houses are recommended; where fox squirrels occur in numbers, metal houses are recommended.

## WOOD NEST BOX

The wood duck nest box shown in the plan is simple and can be made by anyone handy with tools. The box has an elliptical opening designed to keep out raccoons. The opening should be made exactly as shown if it is to admit wood duck hens but exclude raccoons. A circular opening, if large enough to admit wood duck hens, will also admit raccoons. Bull snakes are sometimes a problem in wood houses. Where bull snakes are abundant, metal houses are recommended.

**Material**—The box should be made of rough-cut lumber. Cypress is best, but fir may be used if it is painted with a wood preservative. The rough-cut lumber enables young wood ducks, recently hatched, to climb to the entrance. If dressed lumber is used, hardware cloth should be placed inside the front of the box, below the opening, to serve as a ladder for young ducks.

## METAL NEST BOX

The metal house consists of a 26-gauge metal cylinder 12 inches in diameter and 24 inches high. The conical roof, attached by metal screws, is 15 inches high. Because of its greater durability, a metal plate is preferred to a wood plate for the bottom. The metal plate can be soldered into place, or held in place by metal screws.

An elliptical entrance should be used on metal houses as well as on wood ones to prevent the entrance of raccoons. The metal surface deters squirrels but not raccoons. Wood duck ducklings climb out of their nest cavity when 24 hours old. Therefore, a ladder of  $\frac{1}{2}$ -inch-mesh hardware cloth is recommended on the interior front, between the entrance and the bottom, to enable the ducklings to climb out.

## LOCATION OF NEST HOUSES

Nest houses for wood ducks should be placed over or adjacent to water areas attractive to wood ducks. Water areas favored by wood ducks have overhanging woody cover within a few feet of the water surface, and shrubs or trees, or both, which are partially inundated, at least during the early part of the breeding season.

# WOOD NEST BOX

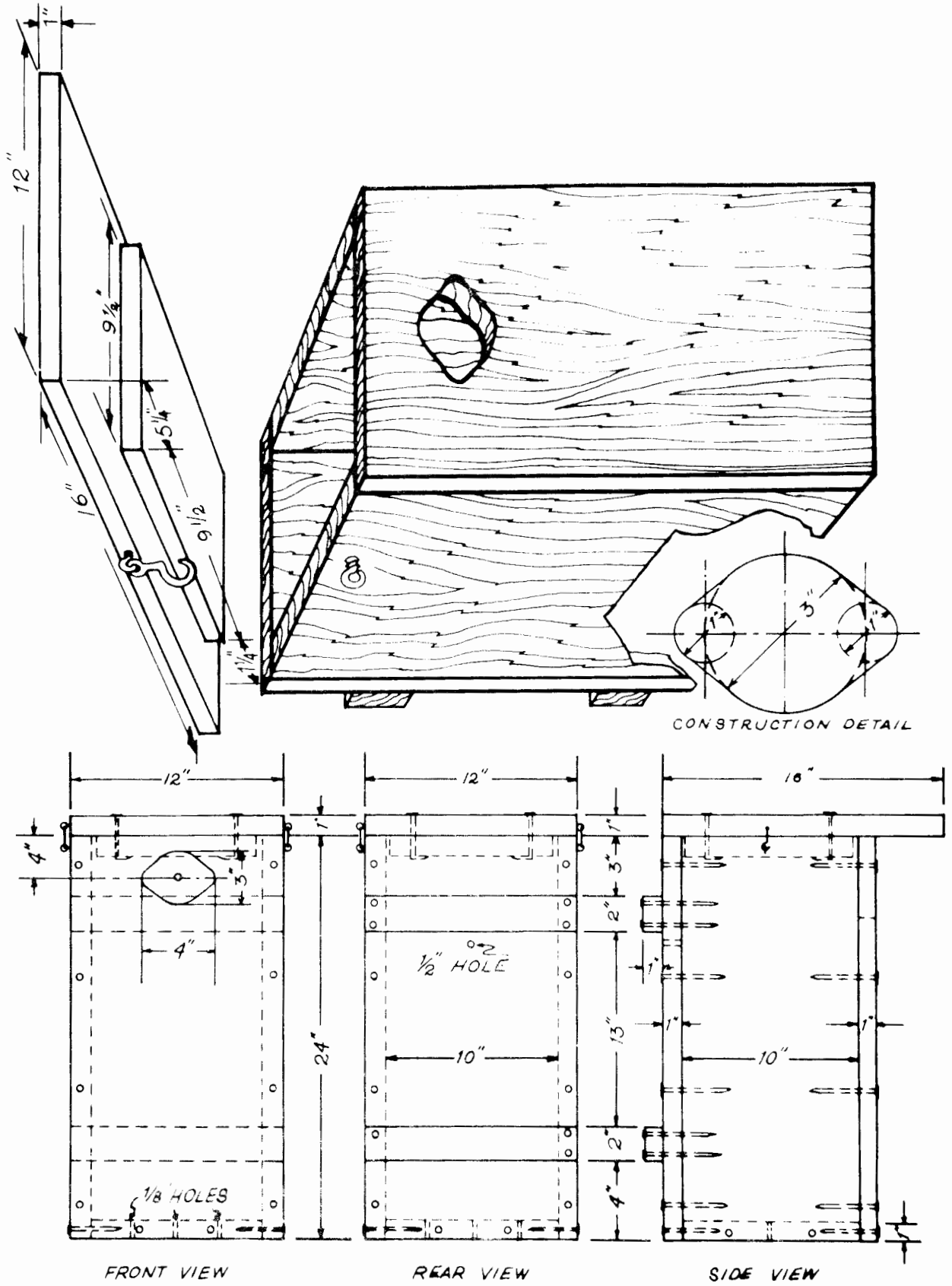

# METAL NEST BOX

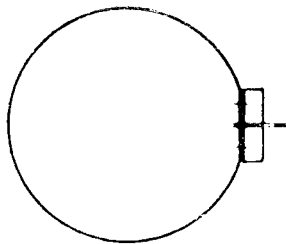
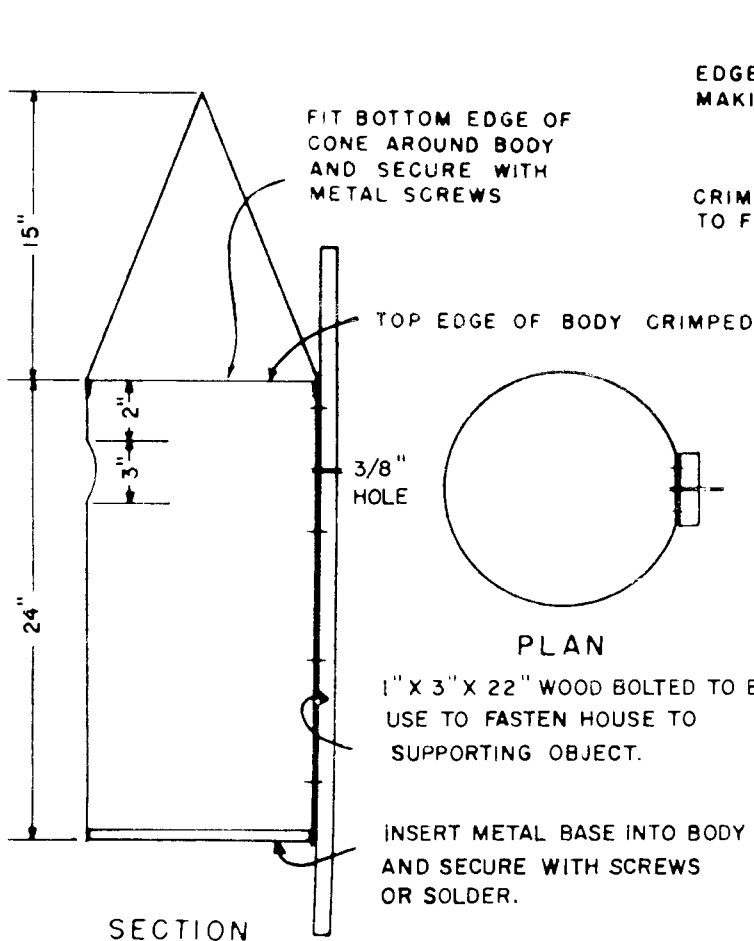
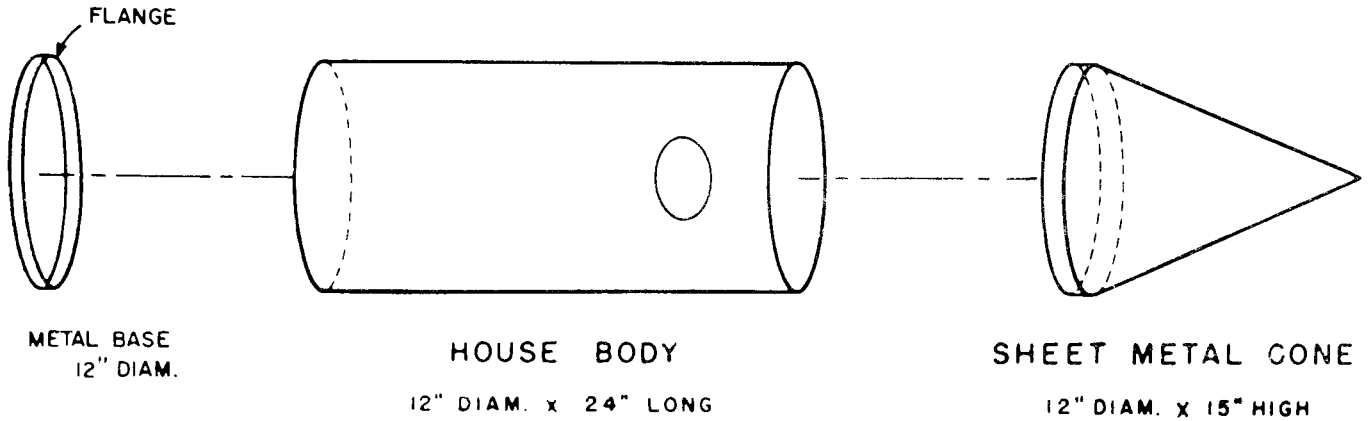

1" x 3" x 22" WOOD BOLTED TO BODY. USE TO FASTEN HOUSE TO SUPPORTING OBJECT.

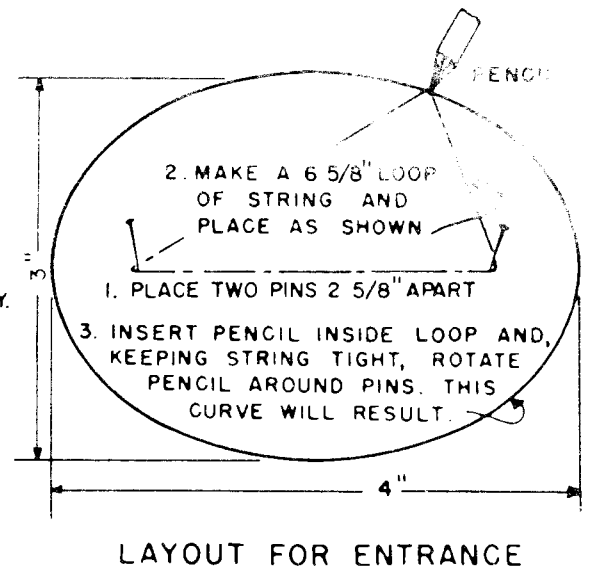
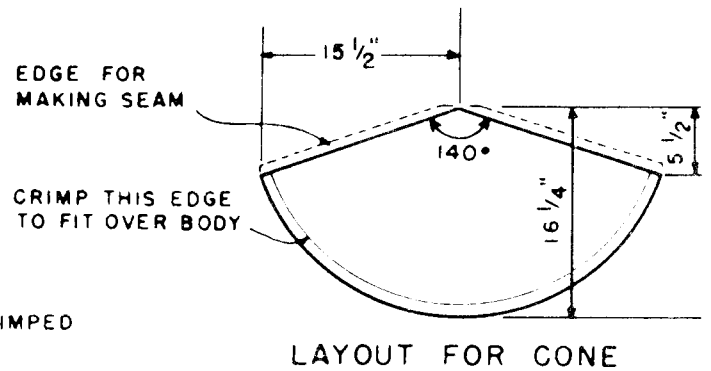

Wood ducks tend to return to areas in which they have previously nested successfully. Yearlings and old birds congregate early in the breeding season, and evidently the yearlings follow the adults to nest areas. Wood ducks are prone to seek nest sites in favorable locations—locations that, in the past, have had an abundance of natural cavities or man-made nest boxes.

Houses erected over water may be placed within 2-3 feet of the highest water level. Where trees or dead snags are lacking, the houses may be placed on wood or metal posts driven firmly into the bottom.

The trunks of trees from the water's edge to as far as 400 yards from the shore provide suitable sites for wood duck houses. Nest houses placed in comparatively open stands of mature trees with large, spreading limbs have a higher rate of occupancy than houses placed in dense stands of young trees. Woodies evidently prefer to fly to their nests through a relatively open canopy and to perch on large, horizontal limbs near their nests. The great preference for nest sites in open areas was demonstrated in an area where nest houses were on dead trees standing in water. Nest houses placed on dead trees have had a higher rate of use than those placed on live trees. Hens tend to avoid selecting houses that are shielded by saplings or overhanging branches, or houses that are attached so insecurely as to move on contact.

In order to capitalize on the homing of adult and yearling hens, nest houses should be erected in groups when placed in woods larger than 40 acres. In such groupings, houses should be placed from 50 to 100 yards apart (a density of one or two per acre).

#### **ATTACHMENT OF HOUSES**

The nest house for a wood duck should be mounted in a vertical position (a) over land—15 to 25 feet above the ground on a tree trunk where no branches shield the entrance, or (b) over water—3 to 25 feet above the water on a suitable tree trunk or a post.

One method of attachment is to insert a lag bolt through a  $\frac{1}{2}$ -inch hole bored in the back of the box,

opposite the entrance, and turn the bolt until the box is drawn firmly against the tree or post. The length of the lag bolt may vary from 3 to 6 inches, depending upon the type of nest box and the thickness of the bark of the tree or the size of the post.

Another method of attachment is to screw a hanger bolt into the tree trunk or post, hang the box on the bolt through the hole bored in the back, and draw the box firmly against the tree or post with a wing nut. Washers should be used between the wing nut and the box, and between the head of the lag bolt and the box. With either a lag bolt or a hanger bolt, the strain imposed on a box by a growing tree can be readily relieved every few years by a few loosening turns of the bolt or the wing nut.

#### **NEST MATERIAL**

Unless houses are provided with materials for a nest foundation, they will *not* be used by wood ducks. Two to 3 inches of sawdust or wood chips should be placed in the bottom of the house to serve as a nest base. At first, the hen wood duck covers the eggs with the sawdust. From the sixth egg to completion of the clutch (usually 12 eggs), she plucks more and more down from her breast to add to the nest. When a ball of down is formed, she covers the eggs with this material before leaving her nest.

#### **SEASON OF NESTING**

Wood ducks begin to nest in early April in central Illinois and continue to start nests until late June. It is advisable to have houses in place by late March.

#### **MAINTENANCE OF HOUSES**

It is advisable to check the attachment and general condition of the houses annually. This check should be made in late winter and should be completed prior to late March. Nest material carried into the houses by other animals such as squirrels, wrens, and starlings should be removed during the annual check.

Prepared by: FRANK C. BELLROSE AND ROBERT CROMPTON,  
Illinois Natural History Survey

