

LEVEL II HYDROGEOLOGIC CHARACTERIZATION REPORT:

Apple Creek near Belltown Greene County, IL (US 67, FAP 310)

Bonnie J. Robinson

Illinois State Geological Survey
Wetlands Geology Section
615 East Peabody Drive
Champaign, IL 61820-6964

Submitted Under Contract No. IDOT SWWIP FY04 to:

Illinois Department of Transportation
Bureau of Design and Environment, Wetlands Unit
2300 South Dirksen Parkway
Springfield, IL 62764-0002

February 4, 2004

**Illinois State Geological Survey
Open File Series 2004-5**

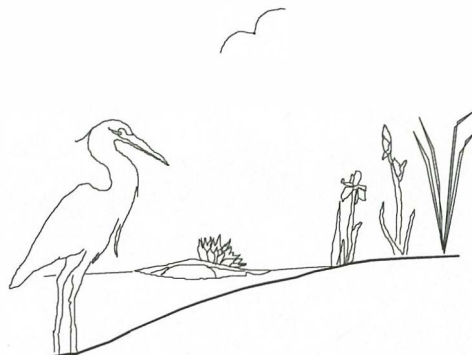

EXECUTIVE SUMMARY

In December 2001, the Illinois Department of Transportation (IDOT) tasked the Wetlands Geology Section of the Illinois State Geological Survey (ISGS) to conduct a hydrogeologic characterization of the potential wetland compensation site at Apple Creek near Belltown in Greene County, Illinois.

Results of this investigation indicate that floodwater from Apple Creek and upland runoff are the main sources of water for this site. Although nearly half of the farm field exhibits wetland hydrology in years when the present levee is not overtopped due to accumulated runoff, if a portion of the levee were lowered to an elevation of 137.8 m (452 ft), the entire farm field would be subject to annual flooding from the creek. The creation of a notch in the Apple Creek levee could be coupled with the modification of the current outlet pipe to allow the control of water levels inside the levee. If all the property located within the levee is not purchased, then the construction of an additional levee along the eastern perimeter of the site to protect adjacent farm fields will be required.

These recommendations were prepared using limited monitoring data. Additional monitoring is recommended to confirm the observed hydrologic conditions.

CONTENTS

EXECUTIVE SUMMARY ii

INTRODUCTION 1

SUMMARY 1

WETLAND COMPENSATION AND SITE DESIGN 1

METHODS 8

 Ground-Water Instrumentation 8

 Surface-Water Instrumentation 8

 Site Monitoring and Surveying 8

 Interpretation of Water-Level Data for Wetland Hydrology 9

SITE CHARACTERIZATION 9

 Setting 9

 Topography 10

 Geology 10

 Soils 10

 Wetlands 10

 Precipitation 10

 Hydrology 12

Wetland Hydrology 12

Ground-Water Hydrology 12

Surface-Water Hydrology 16

CONCLUSIONS 16

ACKNOWLEDGMENTS 18

REFERENCES 18

APPENDIX A: Well Construction 20

APPENDIX B: Water-Level Records 21

FIGURES

Figure 1. Location of the wetland compensation site. 2
Figure 2. Locations of ISGS monitoring instruments 3
Figure 3. Areas exhibiting wetland hydrology in 2003. 4
Figure 4. NWI-mapped wetland on-site 5
Figure 5. Soils types present on-site 6
Figure 6. Suggested alterations 7
Figure 7. Total annual precipitation and deviation in monthly average for the
period 2000 through 2003 11
Figure 8a. Water levels in S-wells 13
Figure 8b. Depth to water in all wells 14
Figure 9. Water level in Apple Creek and the farm ditch versus daily total precipitation 15

PHOTOS

Photo 1. Flooding of the floodplain forest 17
Photo 2. Flooding of the farm field 17

INTRODUCTION

The Illinois State Geological Survey (ISGS) has prepared this report to provide the Illinois Department of Transportation (IDOT) with observations of the hydrogeologic conditions at the proposed wetland compensation site located at Apple Creek near Belltown, IL. The purpose of this report is to provide IDOT with hydrogeologic data and recommendations regarding future wetland compensation activities.

The potential compensation site is located at the intersection of sections 27, 28, 33 and 34, T11N, R12W, in Greene County, Illinois (Figures 1 & 2). It covers a 21 ha (52 ac), roughly rectangular area on the north bank of Apple Creek, roughly 3.2 km (2 mi) southwest of Belltown, Illinois.

Data collection at the site began in April 2002 and will continue until terminated by IDOT. The data currently being collected will be used to measure the extent of wetland hydrology, to determine the impact of hydrologic alterations on the area, to make recommendations regarding design of wetland compensation activities, and to compare the pre- and post-construction hydrology of the site.

SUMMARY

The following factors indicate that the potential for wetland restoration at this site is high.

- Hydrologic monitoring determined that 10 of 18 wells, 8.8 ha (21.7 ac), or 42% of the site, conclusively satisfied the criteria for wetland hydrology in 2003 (Figure 3, Illinois State Geological Survey 2003). While the entire 21 ha (52 ac) site conclusively satisfied the criteria for wetland hydrology in 2002 as a result of widespread flooding (Illinois State Geological Survey 2002), it was a direct result of an extreme rainfall event in the spring of that year. In addition, most of the area south of the levee and portions of the drainage system north of the levee are already classified as NWI-mapped wetlands (Figure 4).
- Floodwater from Apple Creek and runoff from the uplands being impounded behind the levee are the primary sources of water for this site. The magnitude of flooding observed likely outweighs any potential ground-water contribution.
- A well-developed drainage system exists, including levees, farm ditches, and culverts, but it appears to be largely ineffective in preventing wetland hydrology. Apple Creek has overtopped the levee several times in the recent past and interior flooding occurs when runoff from the upland ponds behind the levee.
- Lawson silt loam, both a state and county-listed hydric soil, covers more than 90% of the site (Figure 5).

WETLAND COMPENSATION AND SITE DESIGN

The following considerations and recommendations can be made regarding wetland compensation at this site (Figure 6). These were determined from two seasons of monitoring the water level in Apple Creek, so additional monitoring is recommended to confirm long-term conditions and refine recommended elevations.

- Wetland hydrology would be increased if a portion of the current levee is reduced in height to an elevation of approximately 137.8 m (452 ft). Creation of an armored notch in the levee near the southwest corner of the site would allow floodwaters into the site more frequently, perhaps annually, while retaining the water for a sufficient period of time to expand the area of wetland hydrology. Additional benefits would include sediment reduction in Apple Creek as well as floodwater storage, potentially reducing downstream flooding.

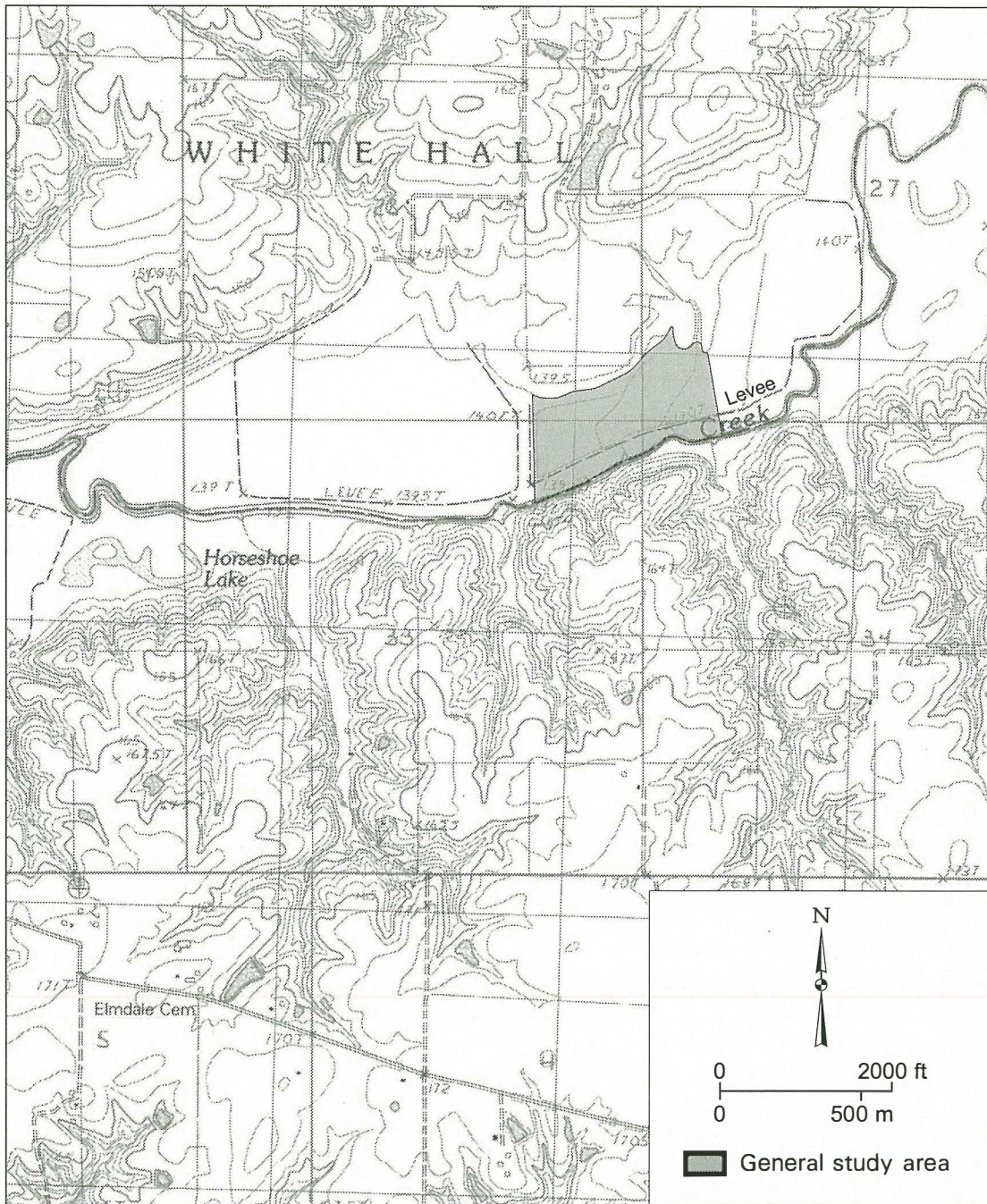

Figure 1. Location of the wetland compensation site (shaded grey) (U.S. Geological Survey 1983).

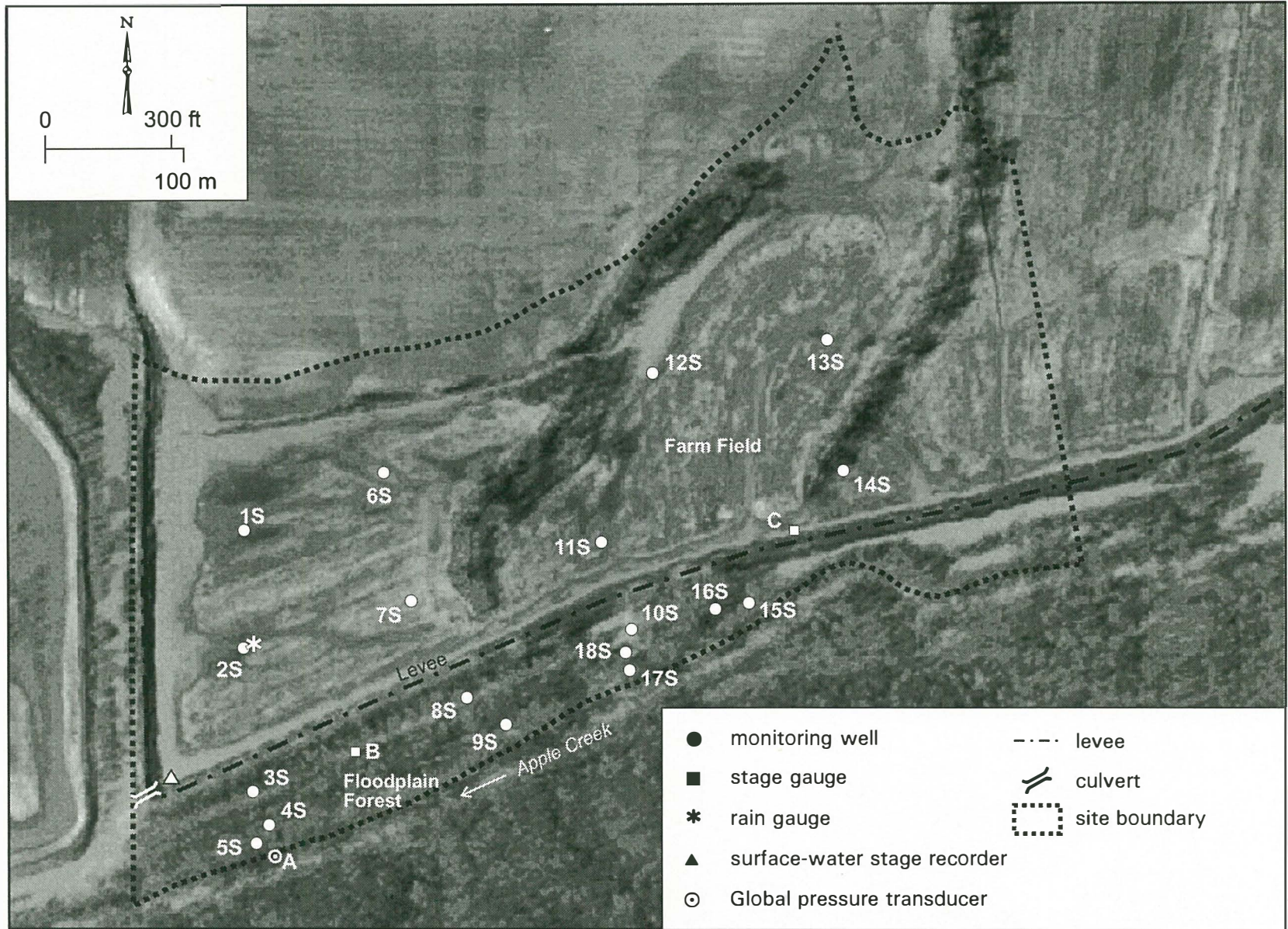
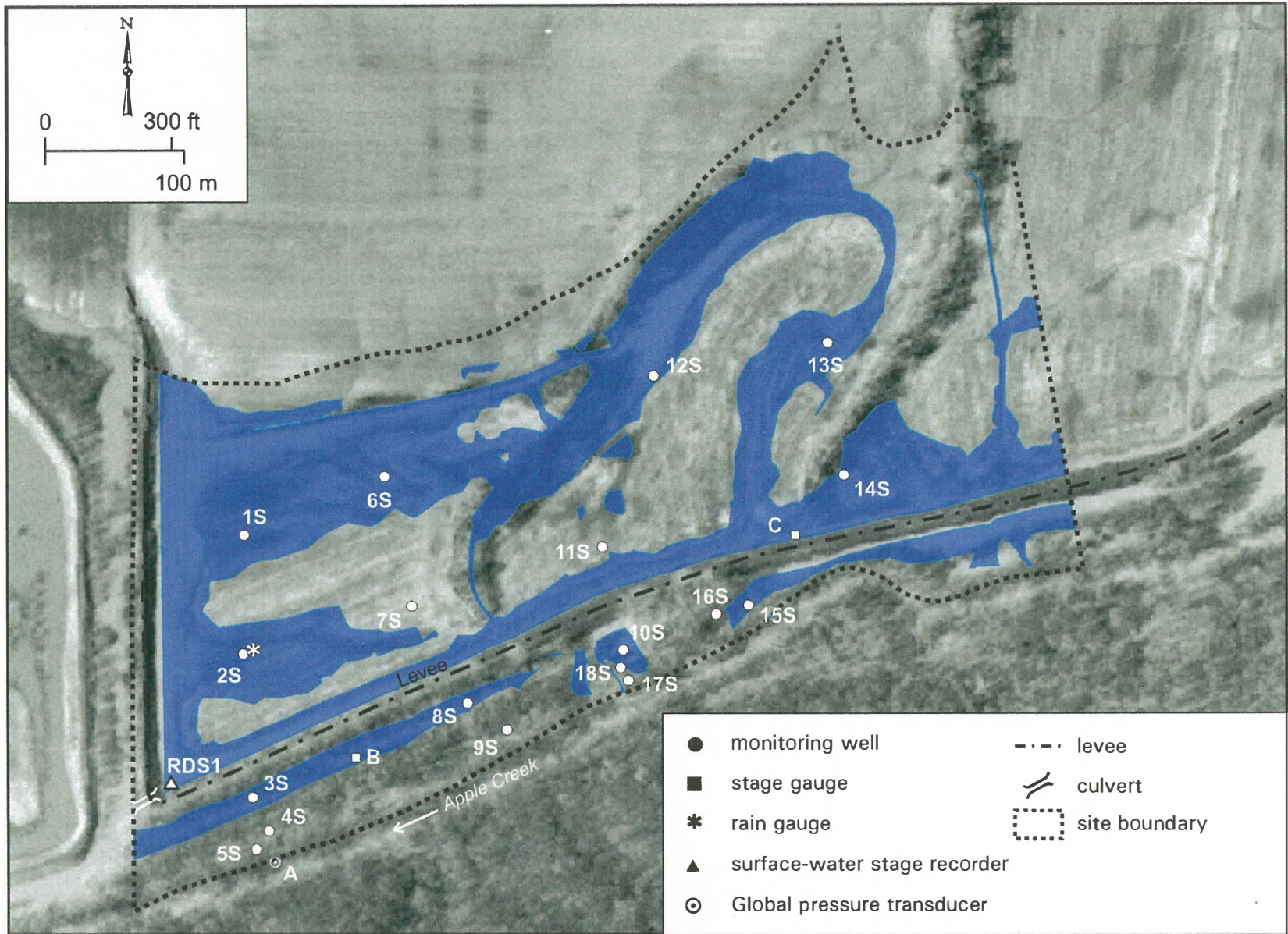

Figure 2. Locations of ISGS monitoring instruments and hydrologic alterations (map based on Illinois State Geological Survey 2001).



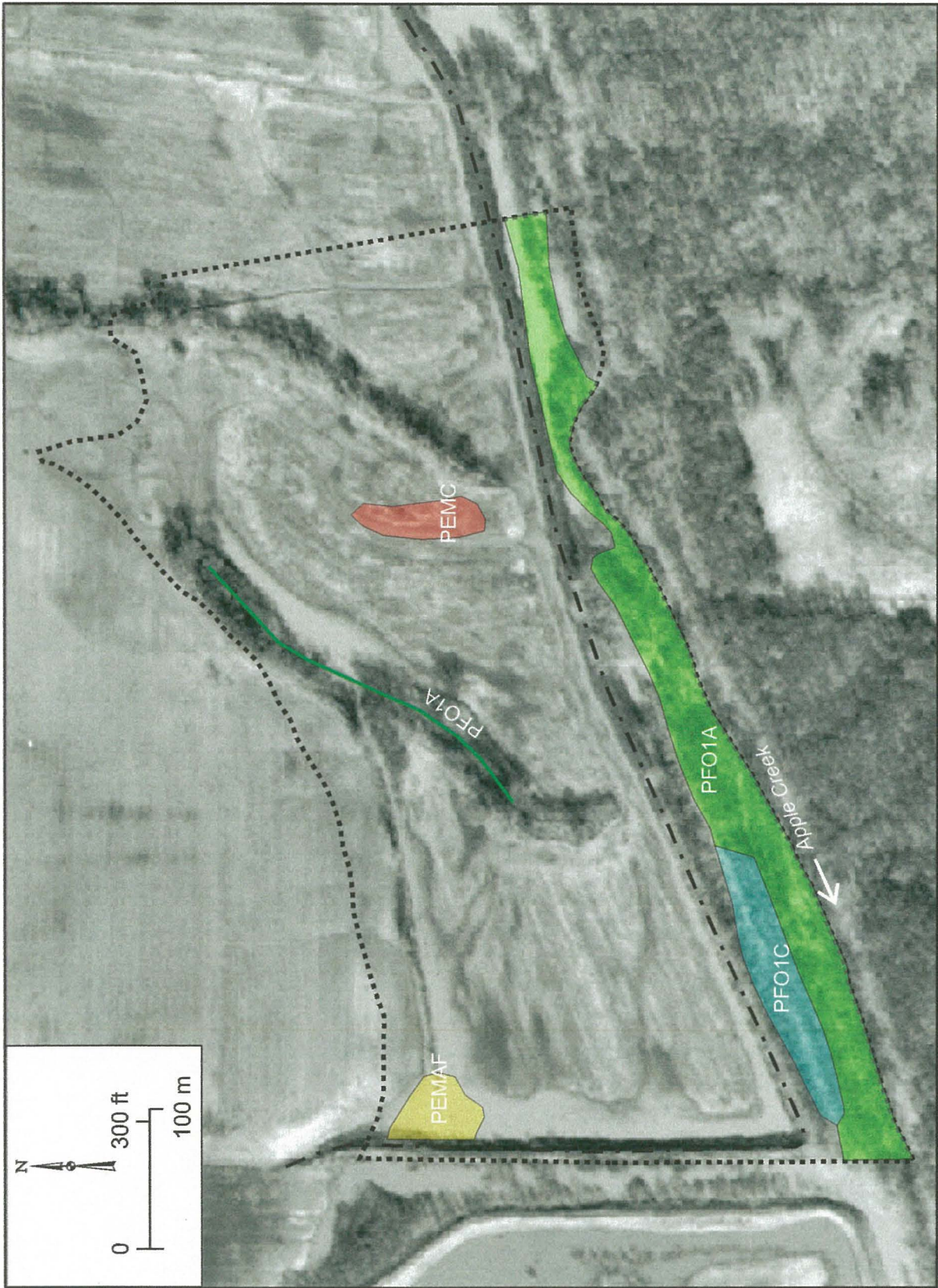

Figure 4. NWI-mapped wetlands onsite (map based on Illinois State Geological Survey 2001, U.S. Fish and Wildlife Service 1996).

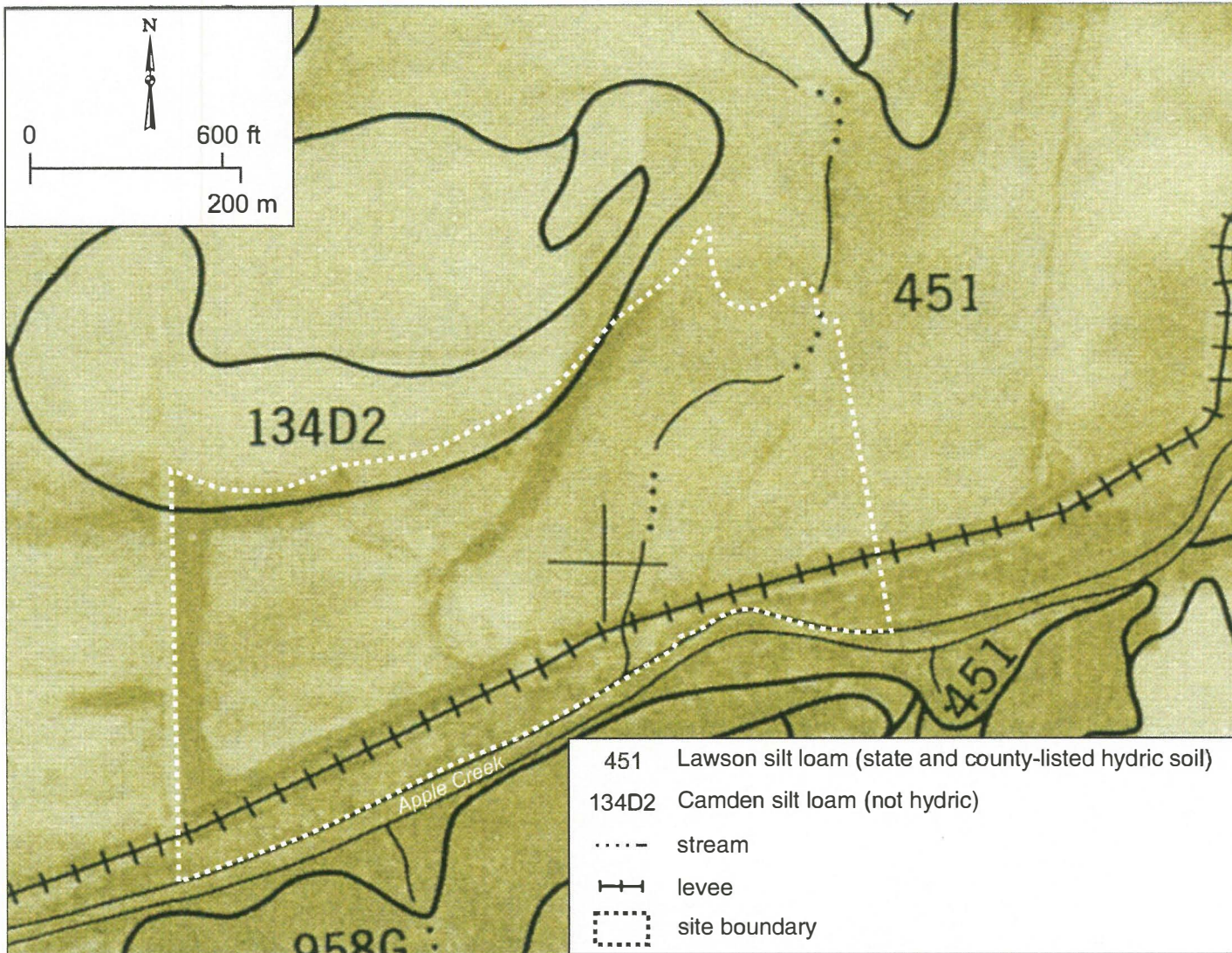

Figure 5. Soil types (map based on U.S. Department of Agriculture 1974).



- The current outlet pipe should be modified to allow the control of water levels inside the levee. A gate valve or similar control measure could allow water to enter the site and not drain from it, when desired. In this fashion, the flow of water entering and exiting the site could be controlled based on conditions in Apple Creek and onsite.
- If the entire floodplain area currently protected by the levee is not purchased, a new levee will have to be constructed to protect the remaining farm fields to the east. The new levee will need to be similar in construction as the current levee and extend to the upland, while an outlet pipe from the unpurchased area to Apple Creek will also need to be installed. These structures will require regular maintenance, which may be costly. Therefore, obtaining the remainder of the leveed area to the east would likely be a more economical solution, and would provide additional mitigation acreage.

METHODS

A variety of instruments was installed at the site in order to monitor water-level fluctuations and map the extent of wetland hydrology (Figure 2) .

Ground-Water Instrumentation

Soil-zone wells (S-wells) were installed at 18 locations throughout the site (Figure 2). Eight wells were installed in a regularly spaced grid in the farm field, ten wells were installed in transects at various elevations in the floodplain forest. These wells are generally 0.75-m (2.5-ft) deep with screens 0.30-m (1.0-ft) in length. S-wells are specifically designed to monitor near-surface saturation. Samples from the borings were described in the field using the Munsell Soil Color Chart (1994 edition) and other standard techniques.

S-wells were constructed with 2.54-cm (1-in) PVC casing and 10-slot PVC screens. All well screens were capped at the base with a 2.54-cm (1-in) PVC cap, with a single drainage hole. Well screens were packed with quartz sand with a grain size of 0.9-mm (0.038-in) and the annulus was then back-filled with $\frac{3}{8}$ " bentonite chips. Well-construction details are provided in Appendix A. Water levels were measured using a Solinst electronic water-level tape.

Surface-Water Instrumentation

Two dataloggers and two stage gauges were installed to monitor surface-water fluctuations onsite (Figure 2), a Global pressure transducer was installed in Apple Creek to monitor fluctuations in the water level, and a Remote Data Systems Ecotone surface-water stage recorder was installed in the ditch north of the levee, in the southwest corner of the farm field.

Stage gauge C was installed in the ditch on the north side of the levee and gauge B was installed in the depression in the woods on the south side of the levee, in an area of semi-permanent inundation.

Site Monitoring and Surveying

The wells, data loggers, and stage gauges were monitored twice per month during the spring (April to June) and monthly thereafter. The entire record of surface-water elevations from stage gauges and depth to water in wells are reported in Appendix B.

The Global pressure transducer was programmed to monitor the water level of Apple Creek at 1-hour intervals, while the Ecotone datalogger monitored the water level in the ditch north of the levee at 3-hour intervals. These intervals help identify short-term events that may not have been detected by the monthly or biweekly readings.

On-site precipitation was measured with a tipping-bucket rain gauge equipped with a datalogger. The on-site data supplemented the precipitation data recorded at White Hall, Illinois (Station #119241), located about 5 miles north of the site. These data were obtained from the National Water and Climate Center (NWCC) of the Natural Resources Conservation Service (NRCS) and the Midwestern Climate Center (MCC) at the Illinois State Water Survey (ISWS). Normal precipitation values are calculated by the NWCC and are based on the 30-year period between 1971-2000. The precipitation data were used to determine the effect of monthly, seasonal, and annual precipitation trends on surface- and ground-water levels.

Temperature data from the White Hall, Illinois station (Station #119241) were obtained to determine the length of the growing season for the region. The growing season (U.S. Army Corps of Engineers 1987) is the period between the last occurrence of -2.2 °C (28° F) temperatures in the spring and the first occurrence in the fall. The median length (5 out of 10 years) of the growing season for the region was 210 days, with the median starting date of April 6 and the median ending date of November 2 (National Water and Climate Center 2003).

The elevations of the monitoring wells, stage gauges, and dataloggers were surveyed each spring with a Sokkia B1 Automatic Level and/or Leica TC702 total station using the NGVD 1929 datum plane. In March 2003, instrument locations were surveyed using a Trimble PathfinderProXR GPS unit. To increase position accuracy, these locations were differentially corrected using the Trimble Pathfinder software.

Interpretation of Water-Level Data for Wetland Hydrology

Inundation and/or saturation to land surface must occur for 12.5% of the growing season to conclusively satisfy wetland hydrology criteria as outlined in the 1987 Corps of Engineers Wetland Delineation Manual (Environmental Laboratory 1987). Saturation and/or inundation to land surface for between 5% and 12.5% of the growing season may meet wetland hydrology criteria if other vegetation and soils criteria are also met, but those data are not included in this report. Water levels within 30 cm (1 ft) of land surface in wells are interpreted to show saturation to land surface due to the presence of a capillary fringe, as suggested by informal Corps guidance. Interpolation or extrapolation will be performed to determine the duration of saturation for wells where manual water-level measurements were collected.

SITE CHARACTERIZATION

Setting

The compensation site is located within the Lower Illinois Watershed, in the floodplain of Apple Creek. Apple Creek flows to the west, towards the Illinois River.

The site is on the north bank of Apple Creek (Figure 1). Most of the site is a farm field protected as part of a large leveed area, but also includes a small portion of floodplain forest not protected by the levee. The levee system includes additional farm fields to the east and connects to the uplands at both ends.

Several north-south ditches extend from the uplands across the farm field into a ditch along the base of the levee. A culvert in the southwest corner of the site drains these ditches into a slough outside of the levee that drains into Apple Creek (Figure 2).

The floodplain forest is characterized by numerous areas of erosion and deposition. A small, approximately 1 m (3.3 ft) high, natural levee is present on the bank of Apple Creek. Areas of scour are interspersed with considerable amounts of woody flood debris, suggesting that large floods with high velocity are relatively common in this area. A ditch is present along the outside of the levee, from the center of the site to the western boundary.

Topography

Not including the levee, the majority of the overall site ranges in elevation from 135.7 m to 137.2 m (445.1 to 450.2 ft). North of the levee, the overall land-surface trend is generally to the southwest. The highest point is along the levee close to the eastern site boundary (140.3 m or 460.2 ft), while the lowest point is at the base of the farm ditch at its south west corner (135.7 m or 445.1 ft). From this point, the farm field ranges up to an elevation of 139.6 m (458 ft) where it connects with the uplands on the north end of the site. Elevations in the floodplain forest range from a minimum of 136.0 m (446.2 ft) to a maximum of 138.4 m (454 ft). Despite the localized areas of scour and fill, the land surface slopes generally to the north, towards the base of the levee.

Although the range of elevation in the floodplain forest is more limited, the forest is marginally higher than the farm field. The lowest point in the forest is at least 0.3 m (1 ft) higher than the lowest point in the farm field. Furthermore, most of the area below 136.9 m (449 ft) south of the levee is confined to the ditches and localized depressions, whereas roughly half of the farm field is below this elevation.

Geology

The modern day valley occupied by Apple Creek mimics a tributary to the Lower Illinois Bedrock Valley (Herzog *et al.* 1994). Bedrock consists of the Mississippian-age lower Valmeyeran Formation (Willman *et al.* 1967), which is mainly limestones and some sandstones.

Bedrock in the general vicinity is overlain by between 15.2 and 30.5 m (50 and 100 ft) of Quaternary deposits (Piskin and Bergstrom 1975). The uplands to the north of the site are underlain by Peoria Loess and Roxanna Silt less than 6.0 m (19.7 ft) thick overlying less than 6.0 m (19.7 ft) of loamy and sandy diamictons of the Glasford Formation. Sediments onsite consist of Cahokia Formation alluvium less than 6.0 m (19.7 ft) thick overlying more than 6.0 m (19.7 ft) of outwash sand and gravel of the Henry Formation (Berg and Kempton 1988, Hansel and Johnson 1996). Borings made onsite confirm the nature of the surficial sediments, composed primarily of silty clay and clayey silt.

Soils

The site is primarily underlain by Lawson silt loam (Figure 5), a state and county-listed hydric soil that is poorly drained and frequently flooded for long durations. A strip along the northern edge of the site consists of non-hydric Camden silt loam. This is a well-drained to moderately well-drained soil generally found on stream terraces and foot slopes (U.S. Department of Agriculture 1974, 1995a, 1995b, 1995c).

Wetlands

NWI maps (Figure 4) indicate that most of the 4.0 ha (10 ac) south of the levee is classified as palustrine, broad leafed deciduous, temporarily or seasonally flooded wetland (PFO1A and PFO1C, respectively). Because large portions of the farm field are located below the elevation of these areas, it is possible that the floodplain could be used as a model for wetlands created in the farm field. Small areas of NWI-mapped wetlands are also present north of the levee; a narrow strip of PFO1A in the center of the site, an area of palustrine, emergent, temporarily, semipermanent flooded wetland (PEMAF) in the northwest corner, and an area of palustrine, emergent, seasonally flooded wetland (PEMC) toward the east side of the site (U.S. Fish and Wildlife Service 1996). These suggest that the farm field is not completely drained.

Precipitation

Average annual precipitation at the nearby White Hall station is 35.6 in. (90.4 cm) (Midwestern Climate Center 2003). Rainfall is typically highest between March and July, peaking in May. Total precipitation at White Hall from April 2002 through November 2003 was 71.9 in. (182.6 cm), which is 105% of the average based on summing monthly averages for that period. The wettest month was May 2002 (196% of the May

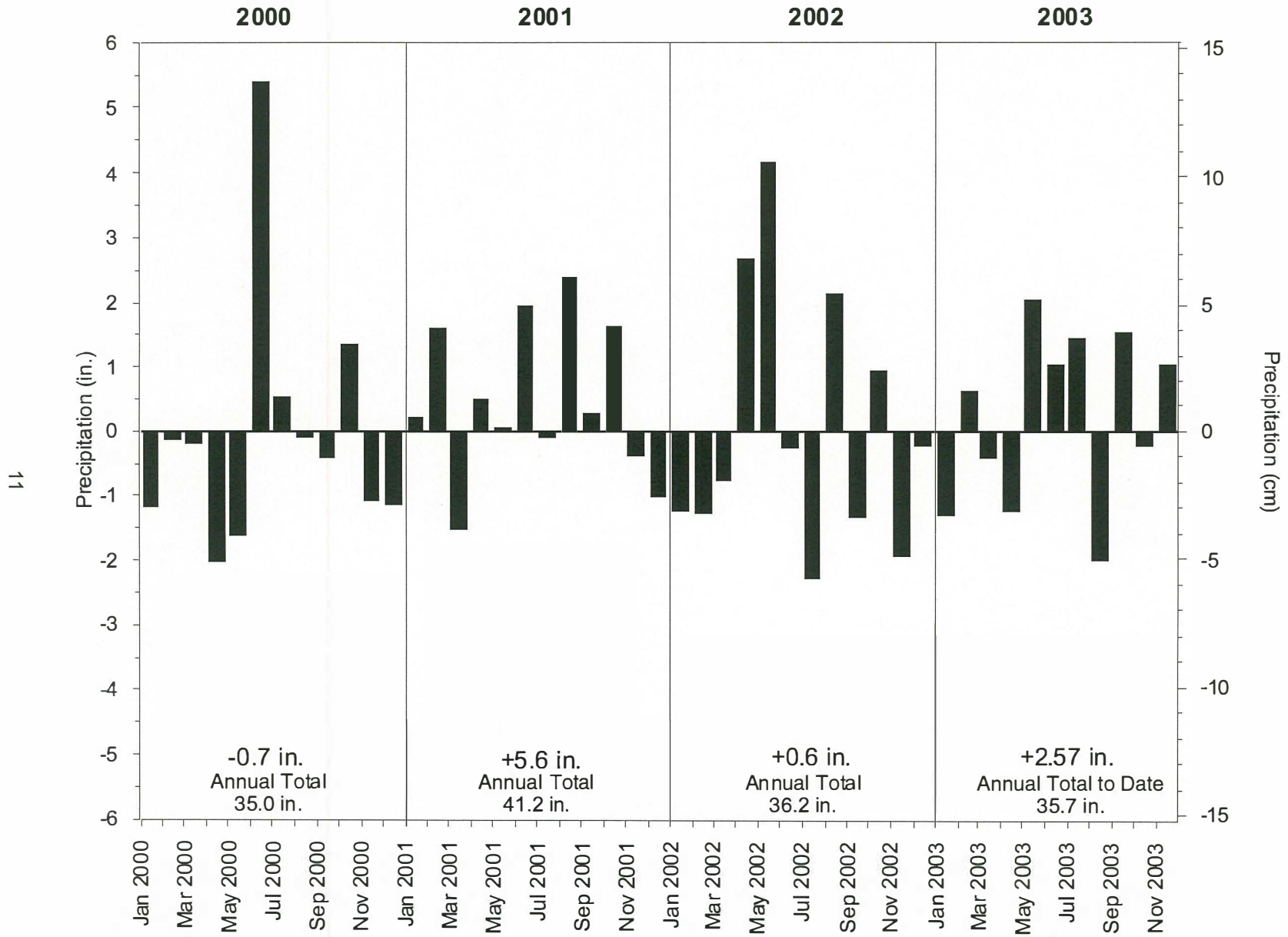

Figure 7. Total annual precipitation and deviation from monthly average from 2000 through 2003 recorded at White Hall, IL (MCC 2003).

average) while the driest month was January 2003 (20% of the January average).

Figure 7 depicts how monthly precipitation at White Hall from January 2000 through November 2003 deviated from the average monthly precipitation. In addition, the deviation from the average annual precipitation is presented as a negative or positive number (Midwestern Climate Center 2003). Dry conditions in the spring of 2003 were offset by above average summer and fall precipitation, resulting in an overall surplus of 2.57 in. (6.5 cm). In 2002, particularly high precipitation values in April, May, and August (175%, 196%, and 175% of monthly averages, respectively) offset the near- to below-average values obtained in the rest of the year. Over the period of monitoring, data from the rain gauge onsite (presented later) indicated overall agreement with the nearby White Hall station.

Hydrology

Wetland Hydrology

In 2002, surface- and ground-water elevations and field observations indicate that saturation and/or inundation occurred over the entire 21.0 ha (52 ac) site for a duration sufficient to conclusively satisfy the criteria for wetland hydrology. This resulted from abnormally high springtime precipitation. Furthermore, the duration of inundation may have been prolonged because the levee may have prevented drainage from the farm field after Apple Creek had receded.

While Apple Creek also flooded in 2003, it did not reach an elevation sufficient to overtop the levee. Despite this lack of flooding, water levels in ten wells met wetland hydrology criteria due to the accumulation of runoff behind the levee or in localized depressions, over a total area of 8.8 ha (21.7 ac) (Figure 3). The extent of wetland hydrology was determined using water levels measured during the longest period of sustained high water levels in 2003. Surface-water levels that were recorded on May 5, 2003 were combined with land-surface data and used to mathematically contour the area that met wetland hydrology criteria, using the SURFER™ computer program. Manual interpretations of water levels in wells agreed with this interpretation, finding that all wells located within the polygon shown in Figure 3 met wetland hydrology criteria (Environmental Laboratory 1987), and all wells outside the polygon did not meet the criteria. Manual interpretations are based on multiple springtime measurements.

While the majority [7.8 ha (19.2 ac)] of the area that exhibited wetland hydrology in 2003 was located north of the levee, it is only roughly half of the total area of the 16.6 ha (41.0 ac) farm field. In order to restore wetland hydrology to the remaining portion of the farm field in years with average precipitation, alterations to the site are required.

Only a small portion, 1.0 ha (2.5 ac), of the area exhibiting wetland hydrology is located within the floodplain forest. Only four out of ten wells in the forest conclusively satisfied the criteria for jurisdictional wetland hydrology, and only two additional wells displayed wetland hydrology for periods between 5 and 12.5% of the growing season. The remaining forest wells did not display wetland hydrology at all. It is therefore possible that on this site, areas that demonstrate wetland hydrology for less than 12.5% of the growing season may exhibit characteristics of jurisdictional wetlands, or that much of the floodplain forest does not conclusively meet wetland hydrology criteria under the current flooding regime. No alterations to the floodplain forest are planned.

Ground-Water Hydrology

Water-level elevations varied little within and between areas in the floodplain forest and the farm field (Figure 8). Overall, the two areas mimicked each other closely, with the largest difference between the highest and the lowest water-level measurement being 0.61 m (2 ft) on April 7, 2003. Overall, water levels followed the general climatic trends, the lowest values were observed in the winter months gradually rising to yearly highs in May and June.

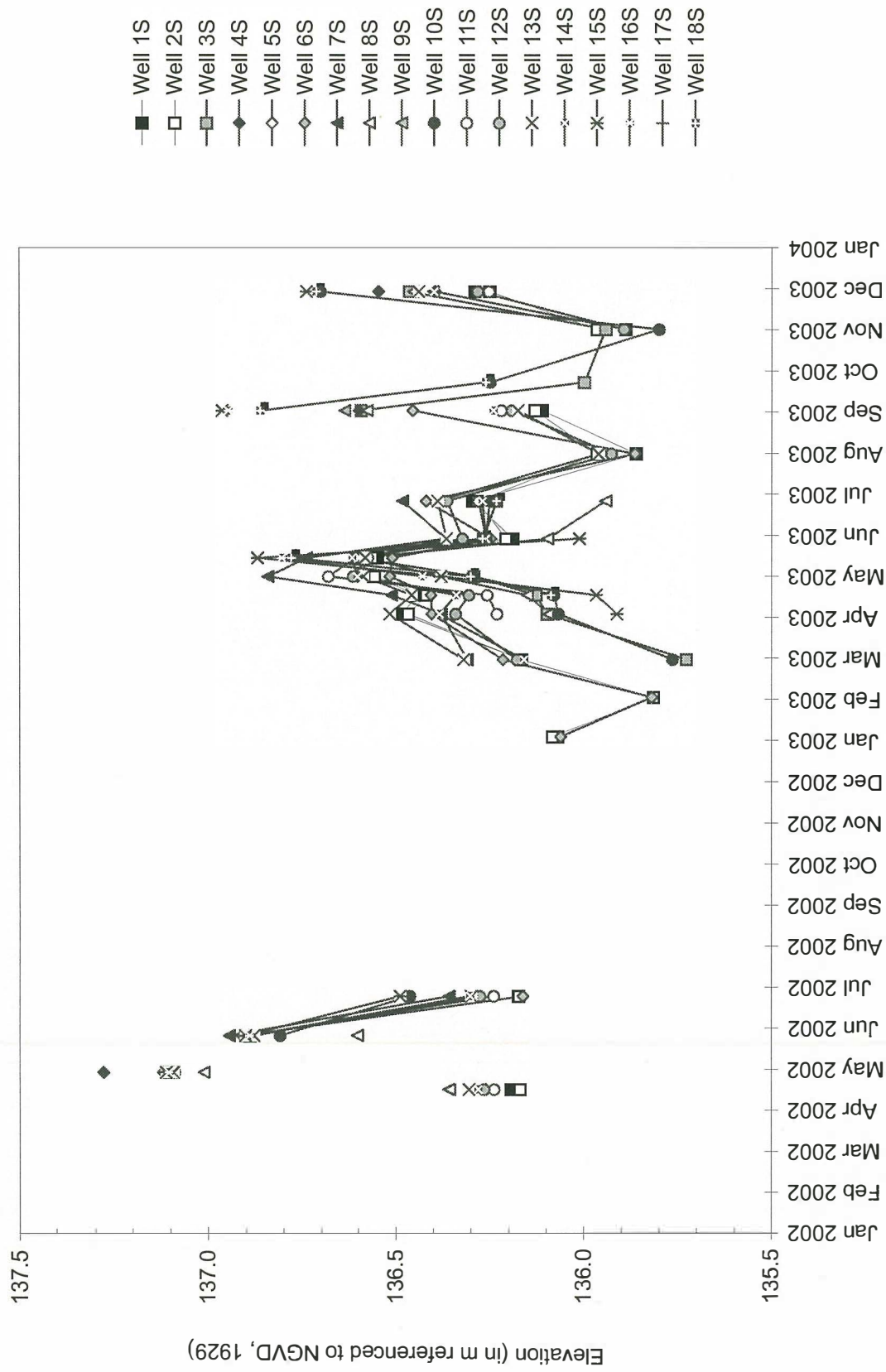

Figure 8a. Water-level elevations in all wells.

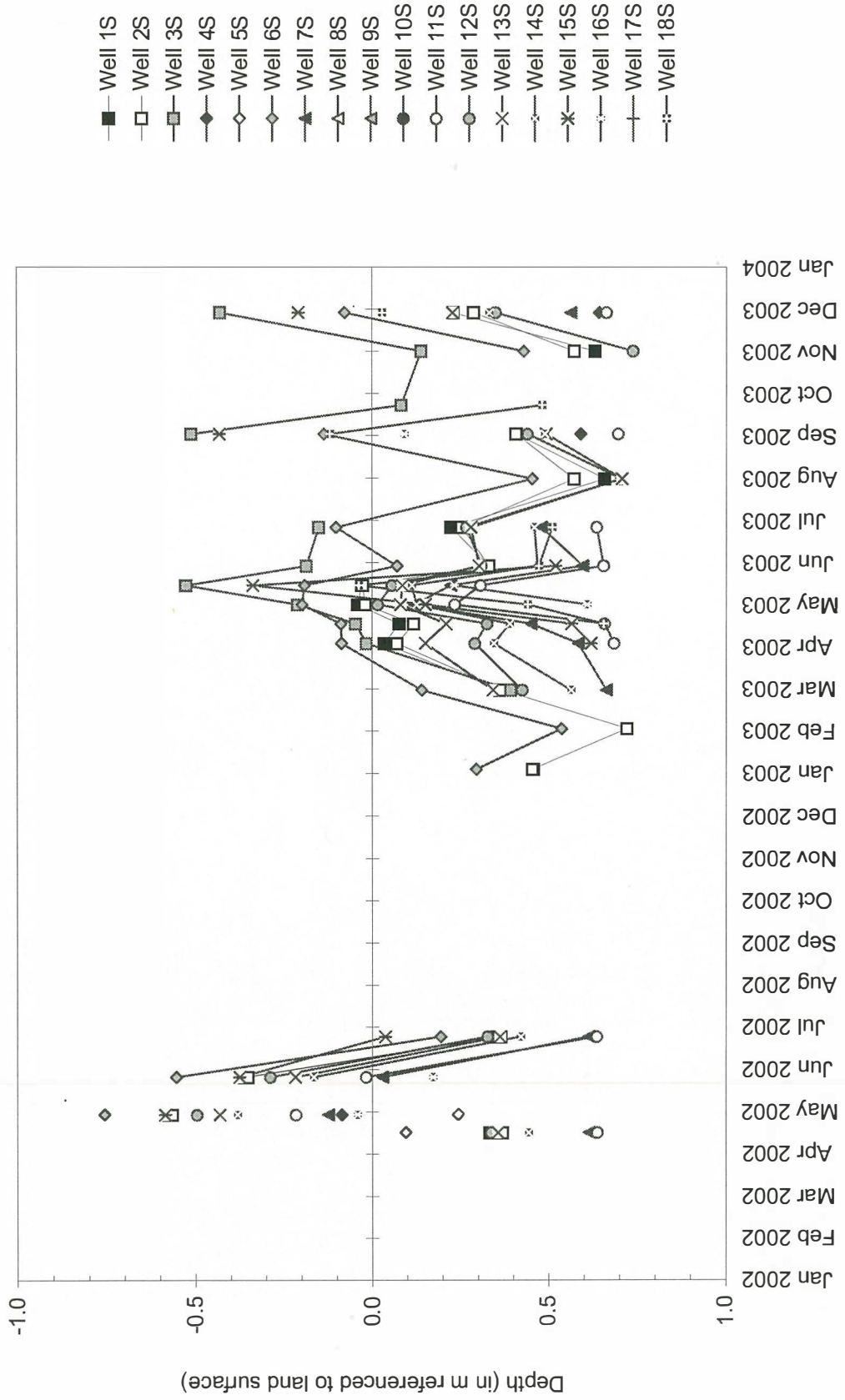

Figure 8b. Depth to water in all wells.

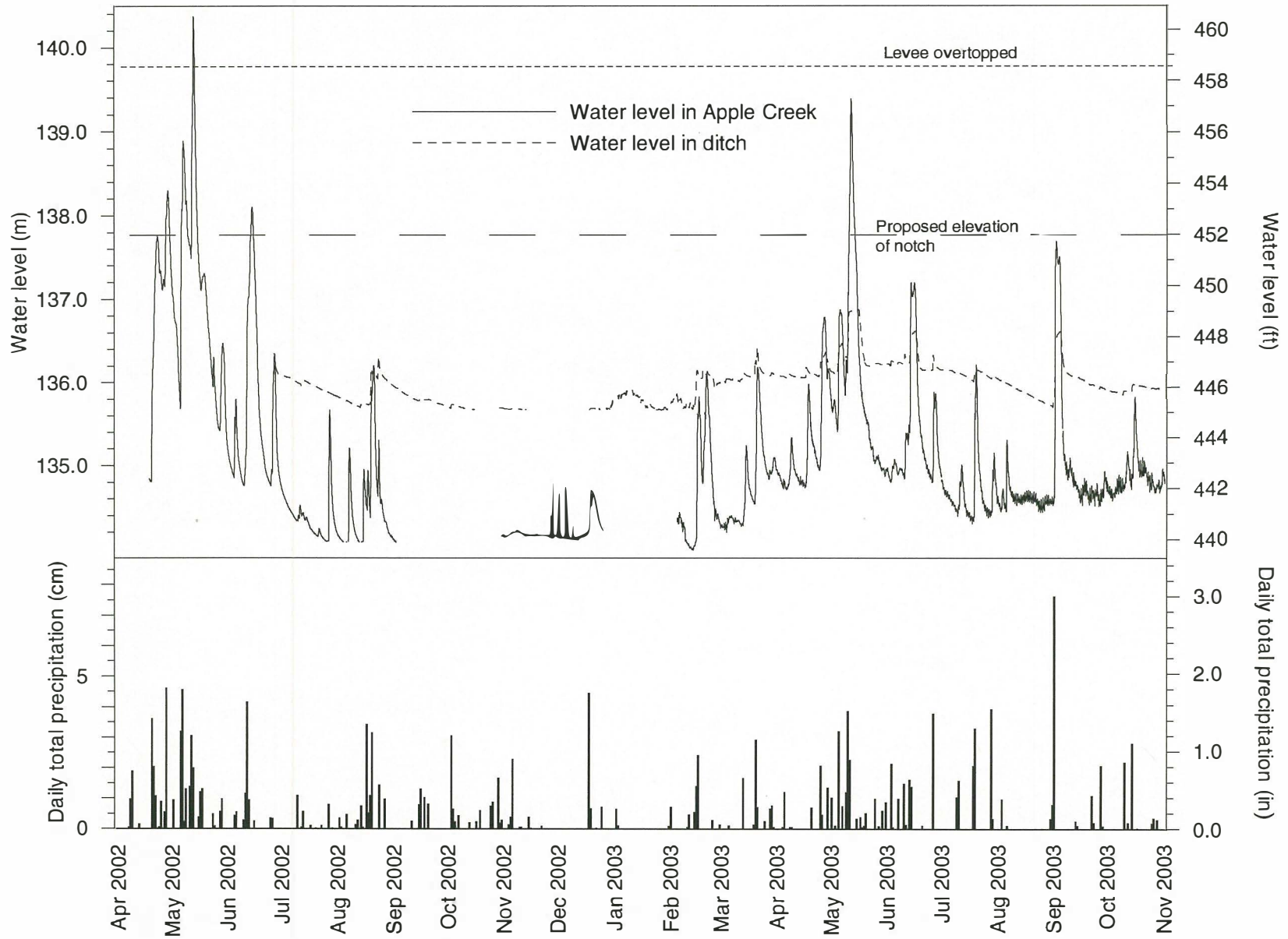

Figure 9. Water level in Apple Creek and the farm ditch versus daily total precipitation: April 2002-November 2003.

Surface-Water Hydrology

The hydrograph for Apple Creek from April 2002 until November 2003 is shown in Figure 9, along with daily precipitation. The baseflow elevation hovers around 134.2 m (440.3 ft). As a result of the natural levee, the water level in Apple Creek must reach an elevation of roughly 137.5 m (451 ft) to exceed its banks. The water level in the creek exceeded this elevation four times during 2002 and twice in 2003.

The highest recorded level during the monitoring period, 140.371 m (460.535 ft), occurred on May 13, 2002. In April and May, 2002, an extended period of well-above average precipitation resulted in a flooding of sufficient magnitude that the levee was overtopped and subsequently breached in the southwest corner of the site (Photos 1 & 2). Field observations indicated that the farm field was flooded from upland runoff prior to Apple Creek overtopping the levee. Unfortunately, a continuous record of surface-water data from the interior of the site was unavailable because the data logger in the farm ditch was destroyed in the flooding.

In spring of 2003, during a period with marginally above-average precipitation, a single flood event during May 10-14 reached a peak of 139.381 m (457.29 ft). While this event inundated the floodplain forest, it was of insufficient magnitude and duration to have significant effect on the farm field. Communication with the landowner confirms that the levee is not overtopped annually. Mr. Edwards has indicated that in recent years, the levee was only overtopped every other year. This is consistent with precipitation records that show extreme rainfall events in the spring of those years (Figure 7), but this trend cannot be confirmed over the long term without continued monitoring. As stated earlier, upland runoff accumulated behind the levee in 2003, causing inundation and saturation over about 8.8 ha (21.7 ac).

Without a large spring rainfall event, it is unlikely that Apple Creek will overtop the levee. In order to capitalize on annual flooding events in years when flooding is of insufficient magnitude to overtop the levee, portions of the existing levee could be lowered to form a notch at an elevation of approximately 137.8 m (452 ft). This elevation would ensure that all the areas in the farm field would be flooded, including those that did not exhibit wetland hydrology in 2003. In 2003, the water level in the creek exceeded this elevation during a single flood event for a total of 67 hours. Continued monitoring will help refine this elevation, because it is based on only two years of monitoring. The most appropriate location for this would be near the southwest corner of the site, capitalizing on a weak spot already observed in the levee. Reinforcement of the lower portion of the levee coupled with the downstream location of the notch would be expected to reduce historic erosion at this location. Because areas that are not being considered for purchase are also protected by the levee, then a levee would need to be constructed to protect the unpurchased parts of the site, or flooding easements would need to be purchased from the landowner.

Total removal of the levee would not be suggested because the levee acts to retain floodwater and runoff from the uplands. Field observations indicate that once the water level in the creek falls, most of floodplain forest drains relatively rapidly, leading to saturation for less than 12.5% of the growing season. Therefore, complete removal of the levee may result in a smaller volume of water being maintained in the farm field.

In order to increase retention of water on the farm field, the drainage culvert in the southwest corner of the site should be altered to allow water in and retain it onsite. This would permit excess water outside the levee to enter the site while reducing the drainage of water from the site.

CONCLUSIONS

The following conclusions regarding the hydrogeology of this site are made.

- Nearly half, or 8.8 ha (21.7 ac), of this site, currently meets the criteria for wetland hydrology during normal years, nearly the entire site is underlain by hydric soil, and the area outside the levee is already classified as NWI-mapped wetland. Widespread flooding in 2002 was the result of an extreme event.



Photo 1. Flooding of the floodplain forest, looking south from the southwest corner of the levee (May 15, 2002).



Photo 2. Flooding of the farm field, looking north from the southwest corner of the levee (May 15, 2002).

- Runoff from the uplands and flooding from Apple Creek are the primary sources of water for this site. Lowering the levee along the southern portion of the site to an elevation of approximately 137.8 m (452 ft) would allow floodwaters to enter the site annually, resulting in nearly the entire site meeting the criteria for wetland hydrology under normal conditions.
- Any farmed areas on the floodplain not purchased by IDOT should be appropriately protected with newly constructed levees of similar elevation as the current levee, including drainage outlets. This is expected to be less economical than purchasing the entire leveed area due to continued maintenance and liability issues.

ACKNOWLEDGMENTS

Geoff Pociask, Paula Sabatini, Brad Ketterling, Kelli Weaver and Kara Hart-Carstens assisted with field work and read water levels. James Miner, Marshall Lake and Katy Werner provided assistance with well installation.

REFERENCES

- Berg, R. C., and J.P. Kempton, 1988, Stack Unit Mapping of Geologic Materials in Illinois to a Depth of 15 Meters: Illinois State Geological Survey Circular 542, Champaign, Illinois, 23 p.
- Hansel, A. and W.H. Johnson, 1996, Wedron and Mason Groups: Lithostratigraphic Reclassification of Deposits of the Wisconsin Episode, Lake Michigan Lobe Area: Illinois State Geological Survey Bulletin 104, 116 p.
- Herzog, B., B. Stiff, C. Chenoweth, K. Warner, J. Sieverling, and C. Avery, 1994, Buried Bedrock Surface of Illinois: Illinois State Geological Survey, Illinois Map 5, Champaign, Illinois, map scale 1:500,000, 1 sheet.
- Illinois State Geological Survey, 2001, Illinois Natural Resources Geospatial Data Clearinghouse, Carrollton NE Digital Orthophoto Quarter Quadrangle, 1998 Data: Illinois State Geological Survey, Champaign, Illinois, available on line at <http://www.isgs.uiuc.edu/nsd/home/webdocs/dogs/>.
- Illinois State Geological Survey, 2002, Annual Report for Active IDOT Wetland Compensation and Hydrologic Monitoring Sites, September 1, 2001 to September 1, 2002: Submitted Under Contract Number IDOT SW WIP FY03 ANTC to Illinois Department of Transportation, Illinois State Geological Survey Open File Series 2002-3, Champaign, Illinois, 341 p.
- Illinois State Geological Survey, 2003, Annual Report for Active IDOT Wetland Compensation and Hydrologic Monitoring Sites, September 1, 2002 to September 1, 2003: Submitted Under Contract Number IDOT SW WIP FY04 to Illinois Department of Transportation, Illinois State Geological Survey Open File Series 2003-16, Champaign, Illinois, 300 p.
- Midwestern Climate Center, December 2003, Midwestern Climate Information System: Illinois State Water Survey, Champaign, Illinois, available online at <http://mcc.sws.uiuc.edu/>.
- National Water and Climate Center, June 2003, National Resource Conservation Service, Climate Analysis for Wetlands by County, available online at <http://www.wcc.nrcs.usda.gov/climate/wetlands.html>.
- Piskin, K., and R. Bergstrom, 1975, Thickness of Glacial Drift in Illinois: Illinois State Geological Survey Circular 490, Champaign, Illinois, 34 p.
- U.S. Army Corps of Engineers, 1987, Corps of Engineers Wetlands Delineation Manual: U.S. Army Corps of Engineers Technical Report Y-87-1, Washington D.C., 100 p.

- U.S. Department of Agriculture, 1974, Soil Survey of Greene County, Illinois, Soil Conservation Service, Washington D.C., 85 p.
- U.S. Department of Agriculture, 1995a, Hydric Soils of Illinois (revised December 15, 1995), Hydric Soils of the United States, National Resources Conservation Service, National Soil Data Access Facility, available online http://soils.usda.gov/soil_use/hydric/states/il.htm.
- U.S. Department of Agriculture, 1995b, County List of Hydric Soils in Illinois, National Resources Conservation Service,
- U.S. Department of Agriculture, 1995c, County List of Soils with Hydric Inclusions in Illinois, National Resources Conservation Service
- U.S. Fish and Wildlife Service, 1996, National Wetlands Inventory Map, Carrollton Quadrangle, Illinois, map scale 1:24,000, 1 sheet, available online at <http://www.isgs.uiuc.edu/nsdihome/>.
- U.S. Geological Survey, 1983, Carrollton, Illinois, 7.5-Minute Series (Topographic): U.S. Department of the Interior, Geological Survey, Reston, Virginia, map scale 1:24,000. 1 sheet, available online at <http://www.isgs.uiuc.edu/nsdihome/>.
- Willman, H., J. Frye, J. Simon, K. Clegg, D. Swann, E. Atherton, C. Collinson, J. Lineback, and T. Buschbach, 1967, Geologic map of Illinois: Illinois State Geological Survey, Champaign, Illinois, map scale 1:500,000, 1 sheet.

Well Number	Elevation of well top (m)	Land surface elevation (m)	Bottom of well **	Well seal - top **	Well seal - bottom**	Sand pack - top **	Sand pack - bottom **	Top of screen **	Bottom of screen **
1S	137.621	136.519	0.719	0.000	0.290	0.290	0.719	0.409	0.683
2S	137.548	136.537	0.832	0.000	0.310	0.310	0.832	0.526	0.788
3S	137.247	136.081	0.805	0.000	0.300	0.300	0.805	0.462	0.757
4S	138.371	137.189	0.763	0.000	0.300	0.300	0.763	0.414	0.718
5S	138.440	137.340	0.745	0.000	0.300	0.300	0.745	0.434	0.700
6S	137.423	136.318	0.769	0.000	0.300	0.300	0.769	0.481	0.728
7S	138.067	136.962	0.742	0.000	0.310	0.310	0.742	0.428	0.706
8S	137.500	136.397	0.754	0.000	0.300	0.300	0.754	0.449	0.720
9S	138.265	137.123	0.720	0.000	0.300	0.300	0.720	0.438	0.688
10S	137.204	136.096	0.738	0.000	0.300	0.300	0.738	0.432	0.705
11S	137.979	136.915	0.760	0.000	0.290	0.290	0.760	0.453	0.727
12S	137.663	136.631	0.796	0.000	0.290	0.290	0.796	0.479	0.750
13S	137.701	136.668	0.813	0.000	0.300	0.300	0.813	0.507	0.780
14S	137.860	136.729	0.765	0.000	0.300	0.300	0.765	0.424	0.735
15S	137.650	136.531	0.733	0.000	0.300	0.300	0.733	0.427	0.700
16S	138.170	137.038	0.760	0.000	0.300	0.300	0.760	0.454	0.725
17S	138.816	137.652	0.794	0.000	0.290	0.290	0.794	0.450	0.748
18S	137.911	136.742	0.780	0.000	0.300	0.300	0.780	0.434	0.732
* NGVD 29									
** reported in m below land surface									

Apple Creek Potential Wetland Compensation Site 2002 to 2003

<i>Water-Level Elevations (in m referenced to NGVD, 1929)</i>													
Date	4/19/2002	4/24/2002	5/2/2002	5/15/2002	5/29/2002	6/27/2002	7/30/2002	9/5/2002	10/15/2002	11/12/2002	12/10/2002	1/6/2003	2/4/2003
Well 1S	136.19	inundated	137.10	submerged	136.89	136.17	dry	dry	dry	dry	dry	136.07	dry
Well 2S	136.17	inundated	137.10	submerged	136.89	136.17	dry	dry	dry	dry	dry	136.08	135.82
Well 3S	*	submerged	inundated	submerged	inundated	damaged	dry	dry	dry	dry	dry	dry	dry
Well 4S	*	inundated	137.28	submerged	dry	dry	dry	dry	dry	dry	dry	dry	dry
Well 5S	*	inundated	137.12	submerged	dry	dry	dry	dry	dry	dry	dry	dry	dry
Well 6S	136.26	*	137.11	submerged	136.91	136.16	dry	dry	dry	dry	dry	136.06	135.82
Well 7S	136.36	inundated	137.10	submerged	136.94	136.36	dry	dry	dry	dry	dry	dry	dry
Well 8S	136.36	inundated	137.01	submerged	136.60	*	dry	dry	dry	dry	dry	dry	dry
Well 9S	dry	inundated	137.11	submerged	dry	dry	dry	dry	dry	dry	dry	dry	dry
Well 10S	*	submerged	137.09	submerged	136.81	136.46	dry	dry	dry	dry	dry	dry	dry
Well 11S	136.24	*	137.09	submerged	136.89	136.24	dry	dry	dry	dry	dry	dry	dry
Well 12S	136.26	*	137.10	submerged	136.89	136.28	dry	dry	dry	dry	dry	dry	dry
Well 13S	136.31	inundated	137.09	submerged	136.88	136.30	dry	dry	dry	dry	dry	dry	dry
Well 14S	136.28	*	137.10	submerged	136.89	136.30	dry	dry	dry	dry	dry	dry	dry
Well 15S	*	inundated	137.11	submerged	136.90	136.49	dry	dry	dry	dry	dry	dry	dry
Well 16S	*	inundated	137.11	submerged	136.89	dry	dry	dry	dry	dry	dry	dry	dry
Well 17S	*	inundated	*	submerged	damaged	dry	dry	dry	dry	dry	dry	dry	dry
Well 18S	*	inundated	inundated	submerged	inundated	*	dry	dry	dry	dry	dry	dry	dry
Gauge B	**	**	**	**	**	136.26	dry	dry	dry	dry	dry	dry	dry
Gauge C	**	**	**	**	**	136.21	dry	dry	dry	dry	dry	136.00	frozen

* no measurement

** not yet installed

S indicates soil-zone monitoring well

Apple Creek Potential Wetland Compensation Site 2002 to 2003

	<i>Water-Level Elevations (in m referenced to NGVD, 1929)</i>											
Date	3/4/2003	4/7/2003	4/21/2003	5/5/2003	5/19/2003	6/2/2003	6/30/2003	8/4/2003	9/5/2003	9/26/2003	11/4/2003	12/2/2003
Well 1S	136.16	136.48	136.44	136.56	136.55	136.19	136.30	135.86	136.11	dry	135.89	136.29
Well 2S	136.17	136.47	136.42	136.56	136.56	136.21	136.28	135.97	136.13	dry	135.96	136.25
Well 3S	135.73	136.10	136.13	136.29	136.61	136.27	136.23	dry	136.59	136.00	135.94	136.46
Well 4S	dry	dry	dry	dry	dry	dry	dry	dry	136.60	dry	dry	136.55
Well 5S	dry	dry	dry	dry	dry	dry	dry	dry	dry	dry	dry	dry
Well 6S	136.22	136.40	136.41	136.52	136.51	136.25	136.42	135.86	136.45	dry	135.89	136.40
Well 7S	136.31	136.38	136.51	136.84	136.74	136.37	136.48	dry	dry	dry	dry	136.40
Well 8S	dry	136.09	136.15	136.38	136.58	136.10	135.94	dry	136.58	dry	dry	136.45
Well 9S	dry	dry	dry	dry	dry	dry	dry	dry	136.64	dry	dry	dry
Well 10S	135.77	136.07	136.08	136.30	flooded	136.26	136.25	dry	flooded	136.25	135.80	136.70
Well 11S	dry	136.23	136.26	136.68	136.61	136.26	136.28	dry	136.22	dry	dry	136.25
Well 12S	136.18	136.34	136.31	136.61	136.57	136.32	136.36	135.93	136.19	dry	135.89	136.28
Well 13S	136.32	136.52	136.46	136.59	136.58	136.37	136.39	135.96	136.18	dry	dry	136.44
Well 14S	136.16	136.38	136.34	136.60	136.62	136.26	136.27	dry	136.24	dry	dry	136.40
Well 15S	dry	135.91	135.97	136.38	136.87	136.01	dry	dry	136.96	dry	dry	136.74
Well 16S	dry	dry	dry	136.43	136.81	dry	dry	dry	136.95	dry	dry	removed
Well 17S	dry	dry	dry	dry	dry	dry	dry	dry	dry	dry	dry	dry
Well 18S	dry	dry	136.09	136.30	136.78	136.27	136.23	dry	136.86	136.26	dry	136.71
Gauge B	dry	136.07	136.13	136.28	136.58	136.24	136.22	dry	136.57	136.07	dry	136.46
Gauge C	136.06	136.09	136.09	136.41	136.21	136.17	136.12	135.98	136.27	dry	dry	136.10

- * no measurement
- ** not yet installed
- S indicates soil-zone monitoring well

Apple Creek Potential Wetland Compensation Site 2002 to 2003

	<i>Depth to Water (in m referenced to land surface)</i>												
Date	4/19/2002	4/24/2002	5/2/2002	5/15/2002	5/29/2002	6/27/2002	7/30/2002	9/5/2002	10/15/2002	11/12/2002	12/10/2002	1/6/2003	2/4/2003
Well 1S	0.33	inundated	-0.58	submerged	-0.36	0.35	dry	dry	dry	dry	dry	0.46	dry
Well 2S	0.37	inundated	-0.56	submerged	-0.35	0.37	dry	dry	dry	dry	dry	0.45	0.72
Well 3S	*	submerged	inundated	submerged	inundated	damaged	dry	dry	dry	dry	dry	dry	dry
Well 4S	*	inundated	-0.09	submerged	dry	dry	dry	dry	dry	dry	dry	dry	dry
Well 5S	*	inundated	0.25	submerged	dry	dry	dry	dry	dry	dry	dry	dry	dry
Well 6S	0.10	*	-0.76	submerged	-0.55	0.20	dry	dry	dry	dry	dry	0.30	0.54
Well 7S	0.61	inundated	-0.12	submerged	0.03	0.62	dry	dry	dry	dry	dry	dry	dry
Well 8S	0.10	inundated	-0.55	submerged	-0.14	*	dry	dry	dry	dry	dry	dry	dry
Well 9S	dry	inundated	0.00	submerged	dry	dry	dry	dry	dry	dry	dry	dry	dry
Well 10S	*	submerged	-1.07	submerged	-0.79	-0.44	dry	dry	dry	dry	dry	dry	dry
Well 11S	0.64	*	-0.22	submerged	-0.02	0.64	dry	dry	dry	dry	dry	dry	dry
Well 12S	0.34	*	-0.49	submerged	-0.29	0.33	dry	dry	dry	dry	dry	dry	dry
Well 13S	0.36	inundated	-0.43	submerged	-0.22	0.36	dry	dry	dry	dry	dry	dry	dry
Well 14S	0.44	*	-0.38	submerged	-0.16	0.42	dry	dry	dry	dry	dry	dry	dry
Well 15S	*	inundated	-0.59	submerged	-0.37	0.04	dry	dry	submerged	dry	dry	dry	dry
Well 16S	*	inundated	-0.04	submerged	0.17	dry	dry	dry	dry	dry	dry	dry	dry
Well 17S	*	inundated	*	submerged	damaged	dry	dry	dry	dry	dry	dry	dry	dry
Well 18S	*	inundated	inundated	submerged	inundated	*	dry	dry	dry	dry	dry	dry	dry

- indicates water above land surface

* no measurement

** not yet installed

bold depth values less than or equal to 0.304 m

S indicates soil-zone monitoring well

Apple Creek Potential Wetland Compensation Site 2002 to 2003

	<i>Depth to Water (in m referenced to land surface)</i>											
Date	3/4/2003	4/7/2003	4/21/2003	5/5/2003	5/19/2003	6/2/2003	6/30/2003	8/4/2003	9/5/2003	9/26/2003	11/4/2003	12/2/2003
Well 1S	0.36	0.03	0.08	-0.04	-0.03	0.33	0.22	0.66	0.41	dry	0.63	0.23
Well 2S	0.37	0.07	0.12	-0.02	-0.03	0.33	0.25	0.57	0.41	dry	0.57	0.29
Well 3S	0.39	-0.02	-0.05	-0.21	-0.53	-0.19	-0.15	dry	-0.51	0.08	0.14	-0.43
Well 4S	dry	dry	dry	dry	dry	dry	dry	dry	0.59	dry	dry	0.64
Well 5S	dry	dry	dry	dry	dry	dry	dry	dry	dry	dry	dry	dry
Well 6S	0.14	-0.09	-0.09	-0.20	-0.19	0.07	-0.10	0.45	-0.14	dry	0.43	-0.08
Well 7S	0.66	0.58	0.45	0.12	0.22	0.60	0.48	dry	dry	dry	dry	0.56
Well 8S	dry	0.30	0.25	0.01	-0.19	0.30	0.46	dry	-0.18	dry	dry	-0.06
Well 9S	dry	dry	dry	dry	dry	dry	dry	dry	0.49	dry	dry	dry
Well 10S	0.26	0.03	0.02	-0.20	flooded	-0.16	-0.15	dry	flooded	-0.15	0.30	-0.61
Well 11S	dry	0.68	0.66	0.23	0.31	0.66	0.64	dry	0.70	dry	dry	0.66
Well 12S	0.43	0.29	0.33	0.02	0.06	0.31	0.27	0.71	0.44	dry	0.74	0.35
Well 13S	0.34	0.15	0.21	0.08	0.09	0.30	0.28	0.71	0.49	dry	dry	0.23
Well 14S	0.56	0.35	0.39	0.13	0.11	0.47	0.46	dry	0.49	dry	dry	0.33
Well 15S	dry	0.62	0.57	0.15	-0.34	0.52	dry	dry	-0.43	dry	dry	-0.21
Well 16S	dry	dry	dry	0.61	0.23	dry	dry	dry	0.09	dry	dry	removed
Well 17S	dry	dry	dry	dry	dry	dry	dry	dry	dry	dry	dry	dry
Well 18S	dry	dry	0.65	0.44	-0.04	0.47	0.51	dry	-0.12	0.48	dry	0.03

- indicates water above land surface
- * no measurement
- ** not yet installed
- bold** depth values less than or equal to 0.304 m
- S indicates soil-zone monitoring well