ICT Usage Amongst Lecturers and Its Impact Towards Learning Process Quality

ANDRE HASUDUNGAN LUBIS
SYED ZULKARNAIN SYED IDRUS
Universiti Malaysia Perlis

ASIAH SARJI
Universiti Utara Malaysia

ABSTRACT

The use of ICT in education has caused substantial changes in learning and brought many benefits to higher learning institutions. However, the development of ICT in the institution of higher education in Indonesia is a minus value compared to other Southeast Asia countries (e.g., Singapore and Malaysia). This is due to several factors which are the lack of knowledge and lack of motivation, especially in Medan, North Sumatera. Medan as the fourth largest city in Indonesia has a low penetration of ICT utilization compared to the other cities which is smaller than it is. Previous studies have found that there is a positive relationship between variables, which are motivation towards ICT usage, knowledge level towards ICT usage, and ICT usage towards learning process quality. This paper addresses the issue by demonstrating a method of study to identify the impact of ICT usage towards learning process quality by lecturers in Medan, Indonesia. As a result, the application of the quantitative research design and data collection through survey questionnaire was considered as the most appropriate method to receive the outcome of the study. Statistical techniques which are the descriptive statistical analysis and regression analysis methods proposed as the means to analyze the data.

Keywords: *ICT, motivation, knowledge, learning process quality, higher education.*

INTRODUCTION

Data is carried at outstanding speeds among and across numerous communication networks referred to as Information and Communication Technology (ICT) system (Freeman & Hasnaoui, 2010). This technology was built to be very much user friendly to human life and handy to use (Hazita Azman, Hussin, Hasim, & Hassan, 2014). In other words, ICT comprises of information technology, telephony, electronic media, and all types of process, transfer of audio, video signals, all control and managing functions based on network technologies as known as the Internet (Celebic & Rendulic, 2011). ICT can be assigned as getting information to personal life such as information about health, hobbies, recreation, and spiritual, and for profession sector namely science, technology, trade, business, and news of the association profession (Gulhane, 2016). As seen today, the use of ICT in education has caused introduction substantial changes in learning and teaching (Lee, 2001). In addition, ICT has brought many benefits to higher learning institutions, and it is evident that any university shunning ICT is imperiling its survival (Ansah, 2013). Countries in Southeast Asia can be divided into three stages of ICT development. Some countries have already integrated the use of ICT in the higher education system (such as Singapore). Others are starting to apply and test various strategies (such as Brunei, Malaysia, Indonesia, Philippines, and Thailand) (Hong & Songan, 2011). Indonesia is included in the group

of countries that have a low use of ICT, due to the distribution of computer and Internet users which are not evenly distributed (Hermana, 2014). Moreover, the development of ICT in the institution of higher education in Indonesia is a minus value of the use of ICT (Perbawaningsih, 2013). This condition makes Indonesia expressed as lower-middle income countries (Hong & Songan, 2011). This is due to the occurrence of the digital divide (Hermana, 2014) which is caused by several factors. These factors include the infrastructure facilities and affordability (Madhubhashini, Salman, Mahmood, & Ahmad, 2013), also the inability to operate a variety of existing information technology (Zulham, 2014), caused by lack of skill or knowledge (Yulfitri, 2008), and motivation (Dijk, 2012). To appropriate a new technology one should first be motivated to use it. When sufficient motivation develops, one should be able to acquire physical access to a computer, the Internet or another digital medium (Dijk, 2012). Also, to determine the functional purpose and important aspects of the interaction of information technology requires the ability and level of knowledge (Akbar, Ratnawati, & Novita, 2010).

The quality of the higher education system can be seen based on the dimensions of the elements are interrelated. One of the dimensions is quality inputs, which are related to the quality of human resources, funding, tools and equipment, buildings and land, energy, and information (Sumarno, 2012). Human resources management in universities (e.g., lecturer) should be able to produce services by the needs of higher education customers (Arwildayanto, 2013). Their competence very sued for being able to continue to improve the quality of the learning process (Suharsaputra, 2015). Lecturers were not only required to be an expert in their field of study of science but also required to be able to master and utilize ICT (Arwildayanto, 2013). ICT usage in the teaching-learning environment can bring a rapid change in society and has the potential to transform the nature of education. Therefore, the role of lecturer in the learning process should be emphasized at this point. It is essential that teachers/lecturers must have basic ICT knowledge and competencies (Fathima, 2013). Without qualified educational personnel's (i.e. lecturers), learning process—which is the main service to the students as the primary customers—will not be able to take place properly (Danarwati, 2013).

Medan is the capital of the North Sumatra province of Indonesia, located on the northern coast; Medan is the fourth largest city in Indonesia behind Jakarta, Surabaya, and Bandung, and the biggest Indonesian city outside Java. The population of the city in 2012 reached about 2.1 million inhabitants (Siahaan, 2011). However, there is an inequality of educational quality between universities in Java, and outside Java, universities outside Java is still lagging far behind than the universities in Java (Putri, 2015). Additionally, in 2014, Internet usage penetration in North Sumatra reached only 25%. Compared to other provinces in Sumatra, namely: Aceh, West Sumatera, Riau, etc., penetration of Internet usage in North Sumatra is still relatively small (APJII, 2015).

This research focuses on the use of ICT in Medan, Indonesia and will be taking the place of environment in higher education institutions meant for lecturers. By emphasizing ICT usage, motivation to use ICT, the level of ICT knowledge, and learning process quality as the variables, this study attempted to discover the relationship between each variable. As for the relationship to be searched are: motivation to use ICT towards ICT usage, the level of ICT knowledge towards ICT usage, and ICT usage impact towards the learning process quality.

CONCEPTS AND THEORY

ICT is the result of human engineering to information process and the process of delivering a message from one party to another resulting in faster, wider distribution, and longer storage (Aghiesna, 2015). In measuring the usage of ICT, this research will refer to empirical studies from previous research. Several studies have pointed out an important distinction between material and physical access and actual use of ICT, that ICT usage can be measured from its pattern and its intensity. The pattern of the ICT usage can be determined by the ownership of the ICTs (i.e. computer and the Internet), types of ICT that have been used (Balraj et al., 2010), the purposes of ICT use (Mumcu & Usluel, 2010), period in the experience of learning about or working with ICT (Mumcu & Usluel, 2010), and the location of its use (Balraj et al., 2010).

Next, to ensure effective deployment of information technology resources in an organization, usage intention and actual behavior of individual users have been heavily examined in the IT adoption research (Tao, 2009). Motivation is a proponent of an individual for performing actions and accomplishing it. A high and low an achievement of a personal is depending on its motivation (Pinder, 2008). Lecturers' positive attitude towards ICT is a must and also an added advantage in the implementation of ICT-related programs (Kandasamy & Shah, 2014). Subsequently, motivation is a major factor influencing lecturer uptake of ICT in their teaching (Cox, Preston, & Cox, 1999). In brief, motivation to use ICT by the lecturer was perceived to be an instance that is affecting the ICT usage (Cox, Preston, & Cox, 1999; Vitanova & Pachemska, 2014).

Knowledge is the result of considering a thing, including the recall of events that never experienced either deliberately or unintentionally and went after people make contact or observation of a particular object (Mubarak, 2007). Technological knowledge and skills have been considered as an essential requirement for teachers to achieve successful ICT implementation in education (Harbi, 2014). An improved understanding of users (e.g., knowledge) concerning the information system will affect the success of the information system developed (Akbar, Ratnawati, & Novita, 2010). To summarize, knowledge level of ICT by the lecturer was perceived to be an instance that is affecting the ICT usage (Gani, Siarap, & Mustafa, 2006; Harbi, 2014; Tezci, 2010).

Learning process is defined as an interaction process between students and lecturers to share and process information with learning resources in a learning environment (Suharsaputra, 2015) (Abi, 2012). A good learning process will form the intellectual abilities, critical thinking and the emergence of creativity and change in behavior or practice or private person based on certain experience (Abi, 2012). The teaching quality encompasses definitions and concepts that are highly varied and in constant flux, there is a growing number of initiatives (actions, strategies, and policies) aimed at improving the quality of teaching (Hénard, 2010). On the other hand, during the last decades, ICT has been introduced in a dynamic way in society and a far lesser degree in education (Tsolakidis, 2004). By using ICT, the lecturer has potential to improve and develop the quality of education by providing curricular support in difficult subject areas (Amin, 2013). ICT can be applied at all stages of the innovative teaching and learning activities ranging from the creation of a learning plan, preparation of materials, presentation materials, learning implementation, to evaluation (Surjono, 2013). ICT has the possibility to develop, enrich, and deepen skills of students, also to help work practices, as well

as strengthen teaching (Amin, 2013). In short, ICT usage was perceived to be an instance that is affecting the learning process quality (Amin, 2013; Cannell, 2013; Obahiagbon & Osahon, 2014).

In this study, The Uses and Gratification Theory (UGT) is used as the underpinning theory. The UGT emerged in 1974 by Jay Blumler and Elihu Katz which is a model of media study that examines why people use media and what they gain from putting forth the effort and energy to do so. This theory examines media consumption by how it is consumed and what benefits it creates for the consumer in other words focus on media effects from “what media do to people” to “what people do with the media” (Cummings, 2008). UGT is a media use theory from mass communications that had a recent and broad application to the problem of understanding motivations (Ruggiero, 2000). As well as UGT is a modern technique used for understanding user motivation in technology adoption and usefulness of this approach in this area of research (Guo, Zhang, & Stevens, 2009). The UGT theory has been applied to various mass and media content, namely Second Life (Gallegoa, Buena, & Noyes, 2016), Internet (Jere & Davis, 2011), Social Networking Sites (Yuan, 2011), Social Media (Phua, Jin, & Kim, 2017), LinkedIn (Basak & Calisir, 2014), Online Shopping (Spang, 2017), and others. As stated by Salman and Pulungan (2017), motivation is the factor that influences the user to select or use the media. Thus, by using the UGT, this study will be conducted to seek the relationship between the motivation to use ICT and ICT usage.

In UGT, typical gratifications for media use can be logically linked to a person's basic needs. Media consumers often seek necessary gratifications like education, entertainment, and information on current events from major media sources (Cummings, 2008). UGT relies on the notion that media cannot effect an individual unless that person has some use for that media or its messages (Rubin, 2002). Then, UGT is used to investigate the relationship between ICT usage and learning process quality as the gratification. At last, knowledge level of ICT is also considered to be a factor that influencing the use of ICT based on empirical studies Knowledge of computer is one of the factors that were proven to have affected computer usage in teaching and learning among teachers (Gani, Siarap, & Mustafa, 2006). In addition, the higher level of knowledge on ICT, the higher its level of use in education (Tezci, 2010). Thus, this study will consider that knowledge level of ICT to be a factor that is influencing the use of ICT.

HYPOTHESIS DEVELOPMENT

In this study, conceptual framework will be obtained from the Uses and Gratification Theory (UGT). Figure 1 shows that matters that are going to be measured in research. The conceptual framework illustrated the antecedent variable (AV1) will give the contribution in affecting the independent variable (IV), (AV2) will give the contribution in affecting the independent variable (IV), and independent variable (IV) will give the contribution in affecting the dependent variable (DV). The antecedent variable that will be used in this study is motivated to use ICT and knowledge level of ICT. The independent variable that will be used in this study is ICT usage. The dependent variable that will be used in this study is learning process quality.

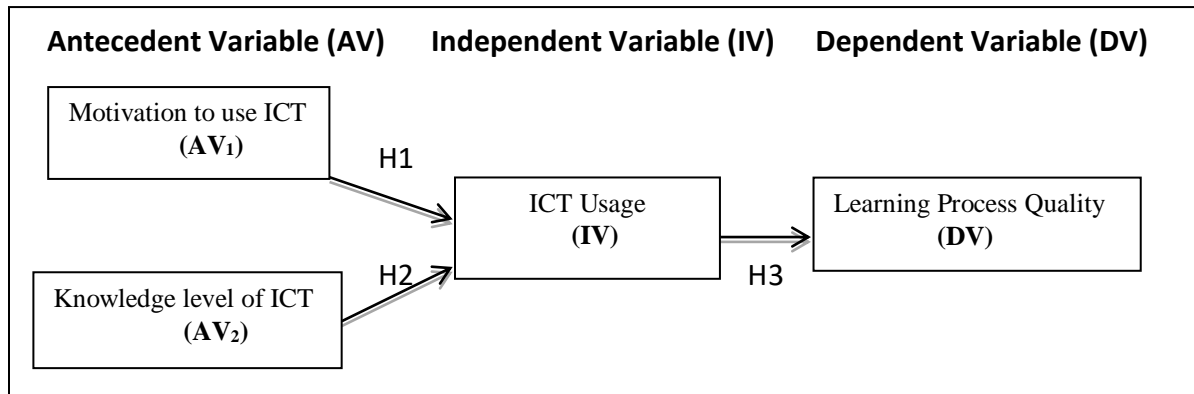

Figure 1: Conceptual framework of the study

According to Figure 1, there are three hypotheses that will be analyzed in this research. Hypothesis 1 (H1) indicates that motivation to use ICT has a positive relationship towards and ICT usage. Then, Hypothesis 2 (H2) considered as a positive relationship between knowledge level of ICT and ICT usage. Then again, Hypothesis 3 claimed that there is positive relationship between ICT usage and learning process quality. Thus, Table 1 shows the summary of all hypotheses which are the summarization of the relationship between motivation to use ICT and ICT usage; the relationship between knowledge level of ICT and ICT usage; and the relationship between ICT usage and learning process quality.

Table 1: Summary of hypotheses

Hypothesis	Summary
Hypothesis 1 (H1)	There is positive relationship between motivation to use ICT and ICT usage.
Hypothesis 2 (H2)	There is positive relationship between knowledge level of ICT and ICT usage.
Hypothesis 3 (H3)	There is positive relationship between ICT usage and learning process quality.

METHODOLOGY

Section 3 shows all of the method and techniques that will be utilized in the study, including research design and data collection method, the population and sample of the survey, reliability, and validity of the measurement, and technique of data analysis. This section divided into four sub-sections. Firstly, is discussed the arrangement of research and data collection, then followed by population and sample size. Then again, the reliability and validity of the measurement also discussed. Finally, the technique of data analysis will be illustrated. This research will be conducted as a cross-sectional research and causal research by using the quantitative approach to gather the data from the respondents regarding investigating the relationship of motivation to use ICT, ICT usage, knowledge level of ICT, and learning process quality. The instrument that involved in the quantitative approach is surveyed to collect data by using the questionnaire. The questionnaire that will be utilized is adopted from several previous types of research which are related to motivation to use ICT; knowledge level of ICT; the

pattern of ICT usage and intensity of ICT usage; and learning process quality. The process of collecting data in this study involved only the primary data. Primary data consists of the data that distributed directly among respondents so that the information or data can be getting initially from the respondents. Through the primary data collection method, the questionnaire will be scattered in self-administered by walking in into universities and by the hard-copy paper to ask for permission from the stakeholders of the universities. Experts of Indonesian language will examine the survey that will be distributed in Indonesian language and before distributed, all of the instruments.

Population refers to the entire group of people, events, or things of interest that the researcher wishes to investigate (Sekaran, 2003). This study takes places in Medan, Indonesia whereas in Indonesia, universities are divided into two categories: a public university is a college held by the government, and the private university is the college owned by individuals (Hong & Songan, 2011). According to Koordinasi Perguruan Tinggi Swasta (Kopertis), which is an institution established by the government for development support for private universities in the working area, in 2015, Medan has as much as 180 universities which are the number of private universities (98.33%; N=177) is much greater than the number of public university (1.67%; N=3). It's illustrated that there are very numerous of private universities in Medan.

Private universities outnumber public providers and play a crucial role in the higher education systems in the countries (Hong & Songan, 2011) and owned its funding sources to improve their quality, particularly an increase in the quality of lecturers (Sucipta, 2013). However, there are only a few percent of private universities that consists able to compete with a public university (Husita, 2015). Hence, the population of this research consists of all lecturers who are working in private universities in Medan, Indonesia. Considering to the pragmatic purposes of cost, efficiency, greater speed and flexibility (Zikmund, 2003), this study will determine the largest private universities and the largest number of students, First, this study will choose Universitas Muhammadiyah Sumatera Utara (UMSU), which has the numerous of lecturers as much as 368 and total 26,615 students. Then, this study will choose Universitas Pembangunan Panca Budi (UPPB) which has a total of lecturers as much as 208 and total 6,030 students. In this study, Universitas Medan Area (UMA) also will be selected, which has a total of lecturers as much as 211 and total 6,823 students. It can be concluded that total of population is 787 lecturers. With regards to the population size of this study which is 787 lecturers, then the representative sample size must be between 254 and 260 (Sekaran, 2003). Hence, this study took the sample size as much as 260. Next, the sampling of the population will be carried out by using probability sampling, namely stratified random sample. A stratified random sample is a random sample in which members of the population are first divided into levels, and then are randomly selected to be a part of the sample (Lubis & Osman, 2015). In this study, stratified random samples are taken from each private university by using strata based on their education level and experience as a lecturer. It is envisaged because those elements appear as the variable which has the greatest effect on the teachers' purposes of using ICT (Mumcu & Usluel, 2010).

Level of Education	Experience as a Lecturer
Master (S2)*	Fresh (F)
PhD (S3)*	Medium (M)
	Old (O)

(*) in Indonesian level

Figure 2: Stratified random sampling for the study

Based on Figure 2, it can be seen that education level can be divided into two levels, namely Master (S2) and PhD. (S3). Experience as a lecturer divided the amount of teaching experience into three levels: little experience/fresh (≤ 5 years; notated as F), medium experience (> 5 but ≤ 10 years; notated as M), and high experience/old (> 10 years; notated as O) (Stes, 2008). Thus, it can be concluded that the sample will be selected as in Table 2.

Table 2: Stratified random samples for each university

UMSU			UPPB			UMA		
Category	N_A	n_A	Category	N_B	n_B	Category	N_C	n_C
S2F	N_{hA}	n_{A1}	S2F	N_{hB}	n_{B1}	S2F	N_{hC}	n_{C1}
S2M	N_{hA}	n_{A2}	S2M	N_{hB}	n_{B2}	S2M	N_{hC}	n_{C2}
S2O	N_{hA}	n_{A3}	S2O	N_{hB}	n_{B3}	S2O	N_{hC}	n_{C3}
S3F	N_{hA}	n_{A4}	S3F	N_{hB}	n_{B4}	S3F	N_{hC}	n_{C4}
S2M	N_{hA}	n_{A5}	S2M	N_{hB}	n_{B5}	S2M	N_{hC}	n_{C5}
S2O	N_{hA}	n_{A6}	S2O	N_{hB}	n_{B6}	S2O	N_{hC}	n_{C6}
Total	368	n_A	Total	208	n_B	Total	211	n_C

Next, from each stratum will be drawn sample by using Simple Random Sampling, which is the simplest form of probability sampling, and forms the building block for many of the other sampling designs (Leeuw, Hox, & Dillman, 2008). From Table 2, population from UMSU is notated as N_A , population from UPPB is notated as N_B as much as 208, and UMA has N_C as much as 211. To determine the value of the sample size from each university, will be using this equation (Kim & Shao, 2013):

$$1 \dots \dots \dots (3.1)$$

where: n_i = sample size for each university
 n = total sample
 N_i = population size for each university
 N = total population

The given the total sample size n how to decide the sample size n_h in stratum h , the simple way is to use the proportional allocation where the sample size in a stratum is proportional to the population size in the stratum by using this equation (Kim & Shao, 2013):

$$n_h = n_i \frac{N_h}{N_i} \dots \dots \dots (3.2)$$

where: n_h = sample size for each stratum
 n_i = total sample
 N_h = population size for each stratum
 N_i = population size for each university

Concerning Table 2 and by using equation (3.1) will be obtained the value of each n_i and also, by using the equation (3.2) will be obtained the value of each n_h . Furthermore, will be explained in Table 3. Based on Table 3, with a total population of 386, sample size for UMSU is as much as 120, then with a total population of 208, UPPB has sample size as much as 65, and UMA which has a total population 211, given total sample size as much as 75. Table 3 is also described how much sample size for each stratum from each university.

Table 3: Total population and sample for each stratum

Stratum	University					
	UMSU		UPPB		UMA	
	N_A	n_A	N_b	n_b	N_c	n_c
S2F	86	31	69	24	57	20
S2M	48	17	68	24	20	7
S20	168	57	35	12	103	36
S3F	2	2	6	2	13	5
S3M	11	4	5	2	1	1
S3O	24	9	1	1	17	6
Total	368	120	208	65	211	75

After getting the value of n_h (sample size for each stratum), it will be performed the simple random sampling using the RANDOM.ORG. RANDOM.ORG is a website that offers true random numbers to anyone on the Internet. The randomness comes from atmospheric noise, which for many purposes is better than the pseudo-random number algorithms typically used in computer programs. Firstly, the name list of the value of n_h (sample size for each stratum), will be given numbers. Then by using RANDOM.ORG, it will get random numbers in each stratum. Then it will be in obtained the names of the respondents from each stratum from each university.

The instrument in this study will be tested for its reliability which involves the construct consistency by using Internal Consistency test which is measured regarding Cronbach's alpha (α). Cronbach's (1951) alpha (α) is one of the most commonly used reliability coefficients and

was advanced based on the requirement to evaluate items scored in multiple answer categories (Ritter, 2010). The Cronbach Alpha reliability is classified based on the reliability classification index where more than 0.9 is excellent, 0.8 to less than 0.9 is very good, 0.7 to less than 0.8 is good, 0.6 to less than 0.7 is moderate, and less than 0.6 is considered poor (Hair et al., 2010). Besides, some of the ways in determining the validity of a measurement can be established through correlation analysis (Sekaran, 2003). A correlation coefficient is a statistical measure of co-variation or association between two variables. Covariance is the extent to which a change in one variable corresponds systematically to a change in another. The Spearman's correlation is appropriate when correlations estimate relationships between continuous variables (Zikmund, 2003; Lubis & Osman, 2015). Spearman's coefficient of correlation is the most widely used methods of measuring the degree of relationship between two variables (Zikmund, 2003). The correlation coefficient (r) ranges from -1.0 to 1.0 . A perfect positive relationship flagged by the value of r equals 1.0 , and if the value of r equals -1.0 , it's indicates a perfect negative relationship exists. The implication is that one variable is a mirror image of the other. As one goes up, the other goes down in proportion and vice versa. If r equals to 0 , then no correlation is indicated (Zikmund, 2003; Lubis & Osman, 2015). Hence, the validity of a measurement will be tested by using coefficient correlation to measure the relationship between the value of each item and value of the total item. After defining the method to testing the reliability and validity of the instrument, this study will do a pilot study. A pilot study is a small scale of preliminary study which is carried out before the main study in order to verify the reliability and validity of the instrument in this study (Khasawneh, 2012). Before applying this method, usually a Pilot Study for testing the questionnaire is conducted to reveal the weaknesses, if any, of the questionnaire. Questionnaire to be used must be prepared very carefully so that it may prove to be effective in collecting the relevant information (Kothari, 2004).

The technique of the analysis that will be used in this study involved two stages. Firstly, the study performed the descriptive statistical analysis in which descriptive analysis including mean, variance, and standard deviation will be used. To measure the level of variables, the mean score for each variable were computed, and to determine the variation of the data will use the standard deviation. Secondly, the range of regression analysis techniques namely Simple Linear Regression and Multiple Regression Analysis will be used to test the hypotheses. Regression is the determination of a statistical relationship between two or more variables and used to determine how the influence of one or more variables on one variable (Kothari, 2004; Lubis & Osman, 2015). As can be seen in Figure 1, the conceptual framework of the study illustrated a linear association that investigates straight-line relationships between a dependent variable and an independent variable, thus this study will use the simple linear regression. However, there are also two antecedent variables, thus this study will use the multiple linear regression. Regression linear is often used to test relational hypotheses (Zikmund, 2003; Lubis & Osman, 2015). Hence, in order to identify the effect of ICT usage on learning process quality will be use simple regression linear.

In addition, while investigating the pattern of ICT usage, respondents can answer more than one option. In analyzing a complex data that is a multifaceted and has different implications, multiple response variables were usually used. These issues due to some variables may be classified into more than one category (Lavassani, Movahedi, & Kumar, 2009). The

multiple response variables are allowed the respondents to select more than one category response option (Koziol & Bilder, 2014). Therefore, this study used the multiple response variables by computing the frequencies for each possible combination.

However, in the use of regression analysis, there are four assumptions that must be met for the results obtained and the tests are not beveled or inefficient (Lubis & Osman, 2015). The tests consisted of Normality test, Homoscedasticity assumptions, Multicollinearity checking, and autocorrelation (Garson, 2012; Saunders, Lewis, & Thornhill, 2012; Lubis & Osman, 2015). Autocorrelation refers to the correlation between the residual values in one periodic time with other residual values in previous time and usually used for time series research (Garson, 2012; Lubis & Osman, 2015). Since this study is a cross-sectional research, thus the autocorrelation is not necessary to be used.

Normality test is aimed to compare the original data with theoretical data and establishes whether the distribution as a whole for a variable differs significantly from an equal normal distribution (Saunders, Lewis, & Thornhill, 2012; Lubis & Osman, 2015). Kolmogorov-Smirnov test is one of the ways to testing the normality of the variables (Saunders, Lewis, & Thornhill, 2012). When the value of significance is greater than α ($\alpha=0.05$) value, so it can be concluded that the data is normally distributed (Lubis & Osman, 2015). Besides, the normality of the data can be seen by using Normal Probability Plot (P-P Plot). Then, if data is concentrated around a diagonal line and follow the direction of the diagonal line, the regression model to fulfill the normality assumptions, on the contrary (Lubis & Osman, 2015).

Homoscedasticity describes a situation where residual (e) in the relationship between independent variables and the dependent variable have equal variances for the entire range of the dependent variable (Garson, 2012; Saunders, Lewis, & Thornhill, 2012). A good regression model should have the occurrence of homoscedasticity (Lubis & Osman, 2015). Homoscedasticity is simple to be seen in a standardized scatter plot by using diagrams plot the dependent variable with a residual budget which is both already standardized (Garson, 2012; Lubis & Osman, 2015). To elaborate, if the distribution is random, it can be said that there is an indication of homoscedasticity (Lubis & Osman, 2015).

Multicollinearity indicates a perfect linear correlation or high level of inter-correlation among the independent variables (Garson, 2012; Lubis & Osman, 2015). The occurrence of multicollinearity makes difficult determines separate effects of individual variables (Saunders, Lewis, & Thornhill, 2012). The common ways to detect whether the regression model have a multicollinearity problem is by using Tolerance value and VIF (Variance Inflation Factor). For the Tolerance value is less than some cutoff value, usually 0.10, it is indicating that there is multicollinearity in the regression model. Then, if there is a large VIF value (10 or above), thus indicate possible multicollinearity problems (Garson, 2012; Saunders, Lewis, & Thornhill, 2012; Lubis & Osman, 2015).

CONCLUSION

ICT has brought many benefits to higher learning institutions and also help to enhance and develop the quality of education by providing curricular support in difficult subject areas (Ansah, 2013; Amin, 2013). The quality of the higher education system expected to be improved by utilizing of ICT among lecturer to increase the learning process quality (Sumarno, 2012; Arwildayanto, 2013; Fathima, 2013). Subsequently, ICT usage was perceived to be

influenced by the lecturer's motivation as well as the knowledge level of ICT (Cox, Preston, & Cox, 1999; Harbi, 2014). Therefore, this study will be organized to know the ICT usage by a lecturer from several perspectives such as the pattern of ICT usage, the intensity of ICT usage. Also, knowledge level of ICT and the motivation to use ICT for teaching will be discovered the relationship towards ICT usage.

This paper highlighted a description of the research methodology used to investigate the impact of ICT usage towards learning process quality in Medan, Indonesia. It also included the sampling design, reliability, and validity of the measurement, and technique of data analysis. Using the application of the quantitative research design and data collection method through a survey questionnaire, the technique of the analysis that will be utilized in this study involved descriptive statistical analysis and regression analysis techniques. The study aims is to give the awareness to the stakeholders in improving the ICT usage by lecturers to increase the learning process quality. Also, expected to provide information on how the role of ICT in the quality of a learning process education through lectures. Finally, the findings of this study can be used to increase human resources development in Indonesia, then to help the Minister of Education in Indonesia to find how to improve the level of ICT usage among lecturers to improving the quality of education in Indonesia. From several previous types of research, it has found that there is positive relationship between variables, which are motivation towards ICT usage, knowledge level towards ICT usage, and ICT usage towards learning process quality. This paper only examined on a draft of the actual study that will be conducted in the future. This article also expected that the following study would discover the results that consistent with the previous studies.

BIODATA

Andre Hasudungan Lubis is currently a Master of Science candidate in the School of Human Development and Techno-communication (iKOM), Universiti Malaysia Perlis (UniMAP), Malaysia. Email: andrelubis2201@gmail.com

Syed Zulkarnain Syed Idrus is a Senior Lecturer in the School of Human Development and Techno-communication (iKOM), Universiti Malaysia Perlis (UniMAP), Malaysia. Email: syzul@unimap.edu.my

Asiah Sarji is a Full Professor at Universiti Utara Malaysia (UUM), Malaysia. Email: asiahsarji@uum.edu.my

REFERENCES

- Abi, P. K. (2012). *Proses pembelajaran musik bagi kelompok band just 4_u di SMA BOPKRI 1 Yogyakarta* (Thesis (S1), Universitas Negeri Yogyakarta, Indonesia). Diperoleh dari <http://eprints.uny.ac.id/8120/>
- Aghiesna, U. (2015). *Pengertian, macam, komponen, dan peranan ICT*. Diperoleh pada October 28, 2015, dari <http://aghiesna.blogspot.my/2015/03/pengertian-macam-komponen-dan-peranan.html>
- Akbar, N., Ratnawati, V., & Novita, V. (2010). Pengaruh pengetahuan teknologi informasi, pemanfaatan teknologi informasi, dan faktor kesesuaian tugas-teknologi terhadap kinerja akuntan internal. *Jurnal Ekonomi*, 18(2), 79-91.
- Amin, S. N.U. (2013). An effective use of ict for education and learning by drawing on worldwide knowledge, research, and experience: ICT as a change agent for education. *Scholarly Journal Of Education*, 2(4), 38-45.
- Ansah, S. O. (2013). Application of information and communication technology (ICT): a comparative analysis of male and female academics in Africa. *Library Philosophy and Practice (ejournal)*, 1087.
- APJII. (2015). *Profil pengguna Internet Indonesia 2014*. Jakarta, Indonesia: Asosiasi Penyedia Jasa Internet Indonesia.
- Arwildayanto. (2013). *Manajemen sumber daya manusia perguruan tinggi*. Gorontalo, Indonesia: Ideas Publishing.
- Balraj, S., Nordin, M. Z., Pandian, A., Ismail, J., & Yi, L. J. (2010). *Young people and new media - Social uses, social shaping, and social consequences*. Pulau Pinang, Malaysia: Universiti Sains Malaysia.
- Basak, E., & Calisir, F. (2014). Uses and gratifications of LinkedIn: An exploratory study. *Proceedings of the World Congress on Engineering 2014 Vol II - WCE 2014*, July 2 - 4, 2014, London, U.K.
- Cannell, K. (2013). *An investigation of the attitudes of a group of lecturers at the University of the Witwatersrand towards the academic use of Facebook and the integration of other information and communications technologies*. Johannesburg, South Africa: University of the Witwatersrand.
- Celebic, G., & Rendulic, D. I. (2011). *ITdesk.info – Project of computer e-education with open access, basic concepts of information and communication technology*. Zagreb, Croatia: Open Society for Idea Exchange (ODRAZI).
- Cox, M., Preston, C., & Cox, K. (1999). *What motivates teachers to use ICT?*. Presented paper at British Educational Research Association Annual Conference, Brighton, UK.
- Cummings, N. M. (2008). *The uses and gratification of communication in virtual spaces: Media depictions of second life, 2002-2008*. Eugene, USA: University of Oregon.
- Danarwati, Y. S. (2013). Manajemen pembelajaran dalam upaya meningkatkan mutu pendidikan. *Jurnal Mimbar Bumi Bengawan*, 6(13), 1-18.
- Dawson, C. (2002). *Practical research methods*. Oxford, UK: How To Books Ltd.
- Dijk, J. A. (2012). The evolution of the digital divide the digital divide turns to inequality of skills and usage. In J. Bus et al. (Ed.), *Digital Enlightenment Yearbook 2012* (pp. 57-75). Amsterdam, Netherlands: IOS Press.

- Fathima, S. (2013). Challenges of ICT in teaching learning process. *International Journal Of Engineering and Science*, 51-54.
- Freeman, I., & Hasnaoui, A. (2010). *Information and communication technologies (ICT): A tool to implement and drive corporate social responsibility (CSR)*. Paper presented at 15th International Conference of the Association Information and Management 2010, AIM 2010.
- Gallegoa, M. D., Buena, S., & Noyes, J. (2016). Second life adoption in education: A motivational model based on uses and gratifications theory. *Computers & Education*, 100, 81-93.
- Gani, A. W., Siarap, K. H., & Mustafa, H. (2006). Penggunaan komputer dalam pengajaran-pembelajaran dalam kalangan guru sekolah menengah: Satu kajian kes di Pulau Pinang. *Kajian Malaysia*, XXIV(1&2), 203-225.
- Garson, G. D. (2012). *Testing statistical assumptions*. Asheboro, USA: Statistical Associates Publishing.
- Guo, Z., Zhang, Y., & Stevens, K. J. (2009). A 'uses and gratifications' approach to understanding the role of wiki technology in enhancing teaching and learning outcomes. Paper presented at European Conference on Information Systems (ECIS) 2009, (p. 77), Pretoria, South Africa.
- Gulhane, G. L. (2016). Integrating ICT in Teacher Education. *MIER Journal of Educational Studies, Trends and Practices*, 1(2).
- Hair, J. F., Black, W. C., Babin, B. J., Anderson, R. E., & Tatham, R. L. (2010). *Multivariate data analysis*. New Jersey, USA: Pearson Education.
- Harbi, H. E. (2014). *An examination of Saudi high school teachers' ICT knowledge and implementation*. Queensland, Australia: Queensland University of Technology.
- Harwell, M. R. (2011). Research design in qualitative/quantitative/mixed methods. In C. Conrad & R. C. Serlin (Eds.), *Research in Education: Pursuing ideas as the keystone of exemplary inquiry* (pp. 147-182). California, USA: SAGE Publications.
- Hazita Azman, A. S., Hussin, S., Hasim, M. S., & Hassan, M. A. (2014). Determining digital maturity among ICT users in Malaysia. *Malaysian Journal of Communication*, 30(1), 23-35.
- Hénard, F. (2010). *Review on quality teaching in higher education*. OECD Publishing.
- Hermana, B. (2014). *Teknologi informasi dan komunikasi di negara-negara Asia: Hubungannya dengan variabel ekonomi makro dan pengembangan sumber daya manusia*. Jakarta, Indonesia: Universitas Gunadarma.
- Hong, K.S., & Songan, P. (2011). ICT in the changing landscape of higher education in Southeast Asia. *Australasian Journal of Educational Technology*, 27(8), 1276-1290.
- Husita, D. (2015). *Alasan kenapa memilih Perguruan Tinggi Negeri (PTN)*. Diperoleh pada December 9, 2015, dari http://www.kompasiana.com/husita/alasan-kenapa-memilih-perguruan-tinggi-negeri-ptn_5575ca11a623bd0d3249d70d
- Jere, M., & Davis, M. S. (2011). An application of uses and gratifications theory to compare consumer motivations for magazine and Internet usage among South African women's magazine readers. *Southern African Business Review*, 15, 1-27.
- Kandasamy, M., & Shah, P. (2014). Knowledge, attitude and use of ICT among ESL teachers. *Proceedings of the Global Summit on Education* (pp. 914-930). Retrieved from http://worldconferences.net/proceedings/gse2013/papers_gse2013/247%20Moghanashwari%20Kandasamy-Parilah%20Bt%20Hj.%20Mohd%20Shah.pdf914-930.

- Khasawneh, M. M. (2012). *Adoption of information and communication technology in teaching and learning environment in Jordanian Higher Education Institutions*. Sintok, Malaysia: Universiti Utara Malaysia.
- Kim, J. K., & Shao, J. (2013). *Statistical methods for handling incomplete data*. London, UK: Chapman & Hall / CRC.
- Kothari, C. R. (2004). *Research methodology methods and techniques*. New Delhi, India: New Age International Publisher.
- Koziol, N. A., & Bilder, C. R. (2014). MRCV: A package for analyzing categorical variables with multiple response options. *The R Journal*, 6(1), 144-150.
- Lavassani, K. M., Movahedi, B., & Kumar, V. (2009). Developments in analysis of multiple response survey data in categorical data analysis: The case of enterprise system implementation in large North American firms. *Journal of Applied Quantitative Methods*, 4(1), 45-53.
- Lee, K. T. (2001). *Using ICT as a subject, tool for curriculum, and co-curricular resource*. In UNESCO-ACEID, *Using ICT for Quality Teaching, Learning and Effective Management* (pp. 41-55). Bangkok, Thailand: UNESCO.
- Leeuw, E. D., Hox, J. J., & Dillman, D. A. (2008). *International handbook of survey methodology*. NY: Taylor & Francis.
- Lubis, Z., & Osman, A. (2015). *Statistika dalam penyelidikan sains sosial*. Kangar, Malaysia: Penerbit UniMAP.
- Madhubhashini, G. T., Salman, A., Mahmood, W. A., & Ahmad, F. (2013). Issues related to Internet diffusion: A case study on ICT related projects in Sri Lanka. *Malaysian Journal of Communication*, 29(2), 69-78.
- Mubarak, W. I. (2007). *Promosi kesehatan sebuah metode pengantar proses belajar mengajar dalam pendidikan*. Yogyakarta, Indonesia: Graha Ilmu.
- Mumcu, F. K., & Usluel, Y. K. (2010). ICT in vocational and technical schools: Teachers' instructional, managerial and personal use matters. *Turkish Online Journal of Educational Technology*, 9(1), 98-106.
- Obahiagbon, K., & Osahon, O. J. (2014). Information and communication technology (ICT) key tool for enhancing teaching and learning in Nigeria: A study of two tertiary institutions in Benin Metropolis. *American Journal of Educational Research*, 2(12), 1257-1259.
- Perbawaningsih, Y. (2013). Plus minus of ICT usage in higher education students. *Procedia-Social and Behavioral Sciences*, 103, 717-724.
- Phua, J., Jin, S. V., & Kim, J. J. (2017). Uses and gratifications of social networking sites for bridging and bonding social capital: A comparison of Facebook, Twitter, Instagram, and Snapchat. *Computers in Human Behavior*, 72, 115-122.
- Pinder, C. (2008). *Work motivation in organizational behavior* (2nd ed.). New York, USA: Psychology Press.
- Putri, A. A. (2015). *Di luar Jawa, Hanya dua universitas yang berakreditasi A!*. Diperoleh pada December 15, 2015, dari <http://edukasi.kompas.com/read/2015/11/17/07090891/PR.Besar.Di.Luar.Jawa.Hanya.Dua.Universitas.yang.Berakreditasi.A>
- Redaksi-Campus. (2015). *Lulusan perguruan tinggi di Indonesia masih jauh tertinggal*. Diperoleh pada September 19, 2015, dari <http://www.campusguide.co.id/lulusan-perguruan-tinggi-di-indonesia-masih-jauh-tertinggal/>

- Ritter, N. L. (2010). *Understanding a widely misunderstood statistic: Cronbach's α* . Southwest Educational Research Association. Paper presented at the Annual Meeting of the Southwest Educational Research Association Feb 17-20, 2010, New Orleans, LA (pp. 1-17).
- Rubin, A. M. (2002). Media uses and effects: A uses and gratifications perspective. In J. Bryant & D. Zillmann (Eds.), *Media effects: Advances in theory and research* (pp. 525-544). Hillsdale: Lawrence Erlbaum.
- Ruggiero, T. (2000). Uses and gratification theory in the 21st century. *Mass Communication and Society*, 3-37.
- Salman, A., & Pulungan, S. M. (2017). Pendedahan diri, motivasi dan kepuasan penggunaan Facebook dalam menjalin persahabatan. *Malaysian Journal of Communication*, 33(1), 438-459.
- Saunders, M., Lewis, P., & Thornhill, A. (2012). *Research methods for business students* (6th ed.). London, UK: Pearson.
- Sekaran, U. (2003). *Research methods for business*. New York, USA: Hermitage Publishing Services.
- Siahaan, R. S. (2011). *Konstruksi identitas diri murid pada Lembaga Pendidikan Non Formal (Studi Kasus pada Pusat Kegiatan Belajar Masyarakat (PKBM) Emphaty Medan)*. Medan, Indonesia: Universitas Sumatera Utara.
- Spang, M. (2017). *An examination of the uses and gratifications of utilitarian and experiential online shoppers*. New York, USA: Rochester Institute of Technology.
- Stes, A. (2008). *Impact of instructional development in higher education*. Gent, Belgium: Academia Press.
- Sucipta, I. N. (2013). *Keunggulan bersaing perguruan tinggi swasta*. Diperoleh pada December 9, 2015, dari <http://www.balipost.co.id/mediadetail.php?module=detailrubrik&kid=4&id=7265>
- Suharsaputra, U. (2015). *Manajemen pendidikan perguruan tinggi*. Bandung, Indonesia: PT Refika Aditama.
- Sumarno. (2012). Rendahnya mutu pendidikan tinggi Indonesia: Penyebab dan strategi peningkatannya. *Jurnal Pendidikan*, 3(2).
- Surjono, H. D. (2013). *Peranan teknologi informasi dan komunikasi (ICT) dalam peningkatan proses pembelajaran yang inovatif*. Kajian dibentangkan di Seminar Nasional Pendidikan & Saintec 18 Mei, 2013, Universiti Malaya Sabah, Sabah, Malaysia.
- Tao, D. (2009). Intention to use and actual use of electronic information resources: Further exploring technology acceptance model (TAM). *AMIA Annual Symposium Proceedings 2009*, (pp. 629-633).
- Tezci, E. (2010). Attitudes and knowledge level of teachers in ICT use: The case of Turkish teachers. *International Journal of Human Sciences*, 7(2), 19-44.
- Tsolakidis, C. (2004). *ICT in Education: The dawn of a new era or the development of an accessory?*. Kefalonia, Greece: University of Aegean.
- Vitanova, V., & Pachemska, T. (2014). Determining the basic motivational factors of teacher to use ICT in their teaching using factor analysis. *IMVI Open Mathematical Education Notes*, 4, 1-8.

- Yuan, Y. (2011). *A survey study on uses and gratification of social networking sites in China*. Athens, USA: Ohio University.
- Yulfitri, A. (2008). *Pengukuran kesenjangan digital dalam penguasaan TIK di lingkungan pegawai pemerintah*. Bandung, Indonesia: Institut Teknologi Bandung.
- Zikmund, W. G. (2003). *Business research methods* (7th ed.). Ohio: Thomson/South-Western.
- Zulham, M. (2014). *Kesenjangan digital di kalangan guru SMP*. Surabaya, Indonesia: Universitas Airlangga Surabaya.