

University of Arkansas, Fayetteville  
**ScholarWorks@UARK**

---

Chemical Engineering Undergraduate Honors  
Theses

Chemical Engineering

---

12-2018

# Sulfate Removal from Mine Impacted Waters

Benjamin Drewry

Jean Morales

Tyler Shock

Derek Richard

Luis Sagarnaga

*See next page for additional authors*

Follow this and additional works at: <http://scholarworks.uark.edu/cheguht>

 Part of the [Chemical Engineering Commons](#)

---

## Recommended Citation

Drewry, Benjamin; Morales, Jean; Shock, Tyler; Richard, Derek; Sagarnaga, Luis; and Yeldell, Benjamin, "Sulfate Removal from Mine Impacted Waters" (2018). *Chemical Engineering Undergraduate Honors Theses*. 132.  
<http://scholarworks.uark.edu/cheguht/132>

This Thesis is brought to you for free and open access by the Chemical Engineering at ScholarWorks@UARK. It has been accepted for inclusion in Chemical Engineering Undergraduate Honors Theses by an authorized administrator of ScholarWorks@UARK. For more information, please contact [scholar@uark.edu](mailto:scholar@uark.edu), [ccmiddle@uark.edu](mailto:ccmiddle@uark.edu).

---

**Author**

Benjamin Drewry, Jean Morales, Tyler Shock, Derek Richard, Luis Sagarnaga, and Benjamin Yeldell

**Benjamin Drewry**

**WERC**

**Honors Thesis Debriefing for WERC:**

I was Team Coordinator for a Senior Design competition known as WERC, as part of a team of 6 chemical engineering undergraduates working on Task 2, Sulfate Removal from Mine Impacted Waters, in which we had to design and build a bench scale system that can reduce sulfate from concentrations of 1500 ppm to less than 250 ppm for a 20 mL/min flowrate, and then scale that system up to 2000 GPM.

As team coordinator I was primarily concerned with ensuring the group ran as well as it could. In terms of tasks I worked on, I developed what is known as a “white paper” for a potential process known as CESR, or Cost Effective Sulfate Removal. I developed a full-scale design and rough economic analysis for this process. I also assisted in development of the nanofiltration and reverse osmosis processes by assisting with and confirming the results of the design we generated using DOW’s WAVE software. I, with Jean Morales, also came up with the final design of the bench scale unit we operated.

I also contacted quite a few individuals in my role; I was notified of the availability of membrane design softwares that we ended up using (ROSA/WAVE) through a contact at DOW, received names of sites we ended up ordering membranes from through another DOW employee (as DOW themselves do not sell the membranes they produce), secured antiscalant for our nanofiltration process through a contact at a mine, and through said mine contact gained more information on our specific task through setting up an over-the-phone meeting with him. Also secured a visit to the mine for which this problem was modeled for, and got water quality analyses regarding the water that would be treated for the full-scale design from the mine as well.

I also assisted in testing of the hot process and nanofiltration systems, predominantly with the conductivity testing for the product water for both processes, which Ben Yeldell also performed. Both of us were trained on an alternate method for determining sulfate concentration, and also performed rough size estimation of the precipitated calcium sulfate particles produced in the hot process, which was performed using a light microscope.

I was the primary writer of the paper we had to submit, and heavily edited it as well. I created parts of the powerpoint we used in our oral presentation to judges, and edited the poster and pamphlets we also made. I also secured two of our three reviewers for the auditing of the paper, and had shirts made for my team to ensure a professional and cohesive look for us.

I also made a run or two to get fittings/containers/piping for the nanofiltration system, as well as another with Tyler Shock to lowes to get fittings for the hot process, and some other ancillary work as well (pump fetching).

# Appendix

**University of Arkansas**

**Task 2: Sulfate Removal from Mine Impacted Waters**

**WERC 2018**

**WERC 2018**

**Task #2**

**March 15<sup>th</sup>, 2018**

**Woo Pig Sulfate**

Ben Drewry  
Jean Morales  
Derek Richard  
Luis Sagarnaga  
Tyler Shock  
Ben Yeldell

Faculty Advisors: Dr. W. Roy Penney  
Dr. Michael Ackerson

**Ralph E. Martin Department of Chemical Engineering**  
**University of Arkansas**  
**Fayetteville, AR**

**TABLE OF CONTENTS:**

**1.0 Executive Summary ..... 3**

**2.0 Introduction ..... 4**

**3.0 Task Parameters ..... 6**

**4.0 Site Overview .....6**

**5.0 Research Methodology..... 7**

**6.0 Full Scale Design ..... 10**

**6.1 Nanofiltration .....10**

**6.2 Hot Process .....12**

**6.3 Waste Disposal .....14**

**7.0 Full Scale Economic Itemization ..... 15**

**8.0 Bench Scale Operation ..... 15**

**8.1 Design .....16**

**8.1.1 Nanofiltration .....17**

**8.1.2 Hot Process .....18**

**8.2 Safety Considerations .....18**

**8.3 Safety Guidelines .....18**

**8.4 Emergency Results and Discussion .....19**

**9.0 Environmental Considerations .....23**

**10.0 Regulations .....23**

**10.1 Permitting .....24**

**11.0 Conclusions and Recommendations .....24**

**12.0 Acknowledgements .....25**

**13.0 References .....25**

## **1.0 EXECUTIVE SUMMARY;**

Woo Pig Sulfate (WPS) has developed two methods for reducing levels of calcium sulfate in mine impacted waters, a “hot process” and a two-stage nanofiltration process. Both processes were designed to treat gypsum saturated water that is currently being pumped via interceptor wells to prevent the spread of a sulfate plume into a nearby community. Each solution was designed for Freeport McMoran’s Sierrita mine in Green Valley, Arizona, which was visited in order to gain insight about the problem. Below 250 ppm on the treated stream, nanofiltration and the hot process achieve overall recoveries of 84 and 99%, respectively. The waste, concentrated gypsum water, can be disposed of via evaporation ponds. Both processes are similar economically, but the hot process produces less waste, therefore requiring a smaller footprint for the evaporation pond, is less complex due to possessing fewer unit processes, and is less intensive maintenance-wise. However, since the hot process is more expensive than nanofiltration and is unused on an industrial scale, both processes are being presented as viable, with preference for either depending on whether the mine wants to maximize water recovery.

A thorough evaluation of potential technologies to treat the impacted mine water was conducted by generating full-scale economic analyses for each process, taking note of the various advantages and disadvantages of each process. When conducting the research, the most important factors taken into account were capital and operating costs, complexity, frequency for maintenance and operator involvement, concentration of sulfate in water recovered, and percent recovery of water fed to the process.

Full scale designs were developed for both the hot process and nanofiltration. In the hot process, water would be pressurized to 15 bar and heated to 200 C, then sent through a series of five crystallizers to allow for precipitation of the calcium sulfate from the water. Treated water would be fed to a hydrocyclone to separate remaining solids in a slurry from the decanted water, then the solid slurry would be sent to a solar pond for evaporation.

The nanofiltration unit would pump contaminated water to 14 parallel bag filters to remove any solids present, followed by 40 parallel membrane housings containing 6 nanofiltration elements each. Concentrate from this first stage of housings would be re-pressurized by a booster pump and fed to 17 more parallel membrane housings. Permeate from both stages would be collected and blended, with the concentrate sent to a solar pond for



evaporation. Both full scale units were designed to handle 2000 gpm of mine water, with feed recovery approaching 90% and 99% for nanofiltration and the hot process, respectively.

On a per 1000 gallon basis, the total costs over a thirty year period equate to \$0.96 and \$1.19 for nanofiltration and the hot process, respectively. However, over a shorter 5 year project life, these equate to \$1.52 and \$1.66 per 1000 gallons for nanofiltration and the hot process.

Bench scale systems for both processes were constructed to demonstrate their respective merits; a nanofiltration unit was built to process 1.0 gpm of water through a system of six membranes elements. Tests on a single membrane element yielded sulfate reduction to below 140 ppm, with single element recovery of 16% of the feed. Multi membrane testing yielded reduction to below 100 ppm, with an overall recovery of 86.5%, after being fed through a series of 6 membrane elements twice.

For the hot process, a pressurized reactor was operated in batch, with a volume of 0.5 L of contaminated water treated at a time. Heating the vessel to 200°C at 15 barg for 60 minutes yielded final concentrations of 233 ppm sulfate in the effluent water, with 98% recovery of the water fed to it. Continuous testing hasn't been conducted at the time of writing, but will be performed in the weeks to come.

## **2.0 INTRODUCTION**

In the mining industry, water is the single most important medium in which most separation processes take place. Water usage ranges from extractive processes such as leaching, to beneficiation processes that include density medium separation and flotation technologies. The water used in these processes can be recycled throughout the life of a mine; however, as mines approach closing, the impacted water becomes an environmental issue. One of the main contaminants present in mine impacted waters is sulfate, which is commonly produced from the natural occurring mineral pyrite.<sup>1</sup> Most of the sulfate present in mine waters is associated with the dihydrate form of calcium sulfate, gypsum. As shown in Equation 1 below, calcium sulfate results from the oxidation of pyrite and other sulfur based compounds during the extraction and beneficiation processes. When oxidized, pyritic sulfates might appear in solution as calcium sulfate if the ore is calcite rich. If calcite is not present in the ore in significant amounts, sulfuric acid will be produced and neutralization will be necessary before further processing due to potential corrosion and other issues linked to acidity.<sup>2</sup> The addition of calcium oxide, commonly

known as lime, neutralizes acidic mine waters, causing the production of gypsum, as shown in Equation 2.

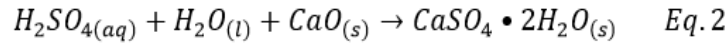
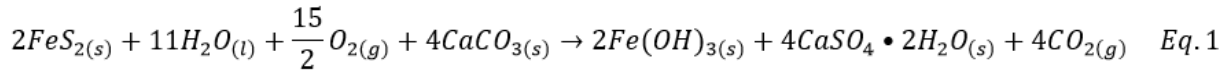

The solubility limit of calcium sulfate at ambient temperature is 2,100 mg/L, which is equivalent to approximately 1,500 mg/L of sulfate, six times the 250 mg/L secondary standard limit of calcium sulfate in drinkable water.<sup>3</sup> Therefore, special care should be directed to the removal of sulfates from mine impacted waters prior to environmental discharge, where it could potentially come in contact with water used municipally.

One of the unique properties associated with treating calcium sulfate is that, like other scale forming salts, it operates on a reverse solubility curve: the hotter temperatures the salt

reaches, the more insoluble it becomes, as illustrated below in Figure 1.<sup>4</sup>

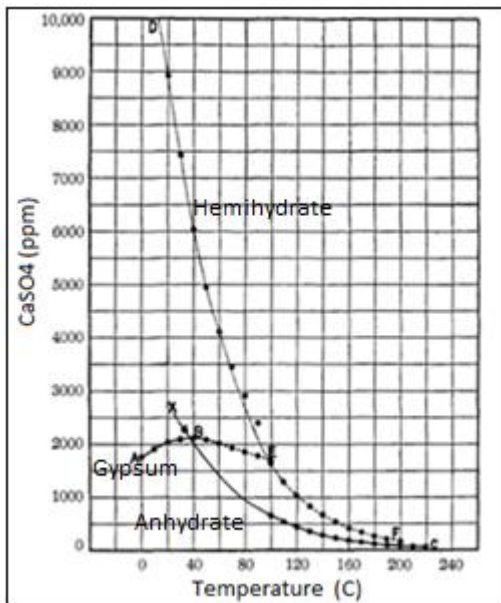
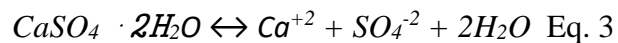

Figure 1: Equilibrium data of calcium sulfate and water

This retrograde solubility limits methods of removing sulfate from solution to utilizing some sort of bioreactor, chemical precipitation method, or evaporatory process. Calcium sulfate also preferentially precipitates in its dihydrate form as solid gypsum,<sup>5</sup> characterized in Equation 3:



This formation and precipitation of gypsum occurs once a solution of water reaches supersaturation, thus necessitating some solid filtration method to ensure proper separation from the treated water.

### 3.0 TASK PARAMETERS AND EVALUATION

The task mandated designing a water treatment process for effectively removing sulfate below 250 mg/L in order to prepare a copper mine for eventual shutdown and closure. The water to be treated, specified in the task statement, is a gypsum-saturated water with the sulfate

concentration corresponding to roughly 1500 mg/L water (1500 ppm)<sup>6</sup>. Success of the process will be measured via conductivity and turbidity measurements. The approach to dealing with the problem statement was as follows:

- Determine potential processes for removing calcium sulfate from water.
- Develop industrial scale design for each potential process.
- Identify potential uses and markets for products generated from processes.
- Generate economic analyses and lifecycle costs for processes on an industrial scale.
- Address issues related to brine/waste generation, re-use of water and combination of technologies.
- Select most economically viable methods and build bench-scale processes for most promising avenues of tackling the problem.

#### 4.0 SITE OVERVIEW

WPS selected the Freeport-McMoran Sierrita Mine outside of Green Valley, AZ for designing the process; this mine both extracts and processes copper and molybdenum. The site originally began mining operations in 1907<sup>7</sup>.

Copper is mined from ore containing copper oxide or copper sulfide.<sup>8</sup>The copper in the sulfide ore is concentrated via milling and flotation cells, after which its concentrate is



sent to a smelter. Spent water from the flotation cells is sent

Figure 2: View of tailings pond at Sierrita Mine facilities

to the tailings pond, shown in Figure 2. Even though the majority of the mine water is recycled back to concentration processes, an appreciable amount seeps into the ground. In order to prevent this sulfate contaminated water from polluting nearby drinking water as it seeps into the ground, the water is pumped to a pond via a series of interceptor wells lining the tailings pond exterior.

Elevated sulfate levels were identified as far back as 1973 by Pima County.<sup>9</sup> This must be dealt with before the copper-producing section of the mine can be closed, as the concentration of the sulfate must be consistent with what is specified on the groundwater discharge permit granted to the mine.

Efforts to deal with this high concentration sulfate water have included the construction of several pilot plant processes, which include ion-exchange technology (IX), sulfate-reducing bioreactors, chemical precipitation, reverse osmosis, and evaporation cannons. There are various benefits and drawbacks associated with each, with the most common drawback being either time required for the process to properly treat the water, as with biosulfate reactors, or the process being prohibitively expensive. It is possible to deal with the contaminated water by utilizing evaporation cannons; however, this method would have no water recovery and there would be a risk of sulfate re-entering groundwater if rain were to resolubilize precipitated sulfates and escape containment. Ideally, most of the water can be pumped into the surrounding groundwater sources to be reused as potable or drinking water after treatment.<sup>10</sup>

## **5.0 RESEARCH METHODOLOGY**

Extensive investigation into removing calcium sulfate from water yielded various potentially viable processes for treating sulfate in mine water: this includes processes such as bioreactors that utilize sulfate-reducing bacteria, barium precipitation, ettringite precipitation, ion-exchange, multiple-effect evaporation, passive solar evaporation, nanofiltration, reverse osmosis, and the “hot process”, developed at the University of Arkansas. Brief descriptions for each are provided below, and pertinent details are summarized in Table 1.

Bioreactors utilize the unique metabolism of two groups of prokaryotes: sulfate-reducing bacteria that reduce sulfate into sulfides, and sulfur-oxidizing bacteria, which simultaneously oxidize sulfides into insoluble elemental sulfur.<sup>11</sup> In barium precipitation, barite reacts with calcium sulfate to produce insoluble barium sulfate and lime, both of which are less soluble than calcium sulfate.<sup>1</sup> The C.E.S.R. process, Cost Effective Sulfate Removal, involves the addition of lime and aluminum hydroxide to precipitate extremely insoluble ettringite.<sup>12</sup>

Ion-exchange removes sulfate when it attaches to the charged sites of an anionic resin subsequent to a cationic resin in columns through which concentrate circulates. As water flows through the column, sulfate ions adhere to the resin, and are subsequently removed by running a

regenerant. Next, solar evaporation takes advantage of the heat provided by the sun to evaporate water, leaving behind any dissolved or suspended particles present in solution. Also, large areas are necessary to increase the contact surface area through which heat is being transferred via convection and radiation.<sup>13</sup>

Furthermore, nanofiltration is a membrane based separation process that combines nanoscale molecular sieving and diffusivity, separating divalent and polyvalent ions from a feed stream. Reverse Osmosis, on the other hand, moves a permeate stream against an osmotic pressure resulting from increased concentration of salts in the retentate stream, while the hot process involves the pressurization and heating of a feed stream, and then crystallization and precipitation of the calcium sulfate.

In order to identify the most viable option to pursue, the critical variables to be satisfied were complexity, operating and capital costs per 1000 gallons of water treated, scalability from benchtop to full-scale, whether the process runs in batch or continuously, and feasibility for dealing with a 2000 gallon per minute flow rate.

Table 1: Alternatives for the Removal of Sulfates from Mine Impacted Waters

Method:	Advantages:	Disadvantages:
Bioreactors	-Simplicity of construction. -Low operating cost.	-Slow, and batch process. -pH sensitive environment.
Solar evaporation	-Simple process. -Virtually no energy cost.	-Water cannot be recovered. -Large plot of land required.
Multi-Effect Evaporation	-Proven for desalination processes. -Reuses heat between vessels.	-High energy costs due to amount of heat needed to vaporize water.
Precipitation: Barium /C.E.S.R.	-High feed recovery. -Optimized to recover as much reactant as possible.	-Reagent is expensive -Relatively complex, large amount of equipment.
Ion Exchange	-Large reduction in sulfate concentration. -High recovery achieved.	-Requires regeneration process. -Introduces new chemicals. -High capital costs.
Hot Process	-Relatively inexpensive. -Very high recovery.	-High energy costs. -Unproven technology.

*Membranes: Reverse Osmosis / Nanofiltration	-Large reduction in sulfate concentration. -Proven processes, easily scalable. -Relatively inexpensive.	-Produces a large amount of brine -Sulfate scaling can occur. -Membrane elements need to be replaced frequently.
--	---	--

\*Reverse Osmosis elements achieve a significantly higher sulfate rejection; however, nanofiltration elements are more economical and work at a lower pressure.

Bioreactors, precipitation, ion-exchange, and multiple-effect evaporation methods were eliminated from consideration: bioreactors as they can't be effectively ran continuously, and precipitation due to high reagent costs. Ion-exchange was eliminated due to difficulties associated with maintaining a packed bed large enough to handle 3000 gallons per minute (due to the volume required for bed regeneration). Ultimately, evaporation was eliminated due to the excessive amounts of heat needed to sufficiently evaporate the feed.

Rough economic analyses were generated for each process sans bioreactors, which is displayed in Table 2.

Table 2: Preliminary Economic Analysis for Water Treatment Processes:

Process:	Capital Cost (\$):	Op. Cost (\$/yr):	NPV (30yrs):	\$/1000 gal treated:
C.E.S.R.	\$4,465,980.00	\$8,678,502.52	-\$86,277,480.96	\$8.71
Evaporation	\$3,093,090.00	\$6,975,298.40	-\$68,848,631.40	\$6.95
Ion Exchange	\$11,487,620.24	\$1,675,081.00	-\$27,278,465.55	\$2.75
Barium Precipitation	\$4,191,044.00	\$1,666,577.24	-\$19,901,725.09	\$2.01
Reverse Osmosis	\$3,735,000.00	\$1,154,946.73	-\$14,622,584.04	\$1.48
Hot Process	\$3,133,200	\$922,107.00	-\$11,825,823.82	\$1.19
Nanofiltration	\$3,695,074	\$619,970	-\$9,539,482	\$0.96

The above data was generated assuming a discount rate of 10%, priced for a total project runtime of 30 years. Equipment was price estimated according to various economic handbooks<sup>14,15</sup> and design textbooks.<sup>16,17</sup> Based upon the economics generated, as well as the general research done, it was decided to build and test bench scale variants of the hot process, reverse osmosis, and nanofiltration processes. However, WPS also wanted to take into account how the relative value of these costs changed when evaluated over a shorter project lifespan, in

addition to taking into account how much water they each recover. The results of this investigation yielded the following data in Table 3.

Table 3: Secondary Economic Analysis for Water Treatment Processes

Process:	Water Recovery %:	\$/1000 gal treated (30yr):	\$/1000 gal treated (5yr):
Reverse Osmosis	90%	\$1.48	\$2.04
Hot Process	99%	\$1.19	\$1.66
Nanofiltration	90%	\$0.96	\$1.51

## 6.0 FULL SCALE DESIGN

### 6.1 Nanofiltration:

Nanofiltration is a membrane-based separation process that combines nanoscale molecular sieving and diffusivity mechanisms while taking advantage of electrostatic, solubility, and dielectric interactions between species in solution and the membrane. However, the most important characteristic of these membranes is the presence of negative groups on their surface, allowing for retention of monovalent anions, while rejecting divalent and polyvalent anions such as sulfate.

An initial feed with a flow rate of 2000 gpm at ambient temperature and pressure is mixed in a mixer with 61.6 mL/min of a phosphonic acid based antiscalant, as shown in Figure 3. After being pretreated, the feed is then pressurized up to 90 psig by pump P-1. The pretreated pressurized feed is split into 40 parallel streams, each of which is bag filtered to remove solids, and subsequently enter first-stage membrane housings, E-1. Each membrane housing contains six membrane elements connected in series, which means that the concentrate exiting each element becomes the feed of the next element.

After the feed exits the first stage, 60% of the feed, 1200 gpm, is recovered in the permeate stream, S-6, at a concentration of approximately 20 ppm of sulfate. The remaining 40% ,800 gpm, of the feed exits as the concentrate stream, S-3, having a concentration of 3470 ppm sulfate, and a lower pressure.

To overcome the rise in concentration and the pressure drop, an interstage pump, P-2, is necessary to pressurize S-3 up to 115 psig prior to entering the second stage housings, E-2. The

re-pressurized concentrate stream, S-4, is then split into 17 parallel streams, each of which enters a membrane housing similar to those described in the first stage.

After processing the re-pressurized concentrate stream through the second stage, 60% of this feed, 480 gpm, is recovered in a permeate stream, S-7, at a concentration of approximately 51 ppm. Simultaneously, 40% of the feed, or 320 gpm, exits the second stage as the final concentrate, S-5, at a concentration of 8600 ppm. After passing through the second stage, the permeate streams from both stages are combined, S-8, to achieve a total recovery of approximately 84% of the initial feed with a concentration of 27 ppm sulfate. If desired, some of the feed can bypass the system in order to raise the concentration of the permeate stream up to 250 ppm sulfate, in order to improve recovery. All of this information is tabulated in Table 4 below.

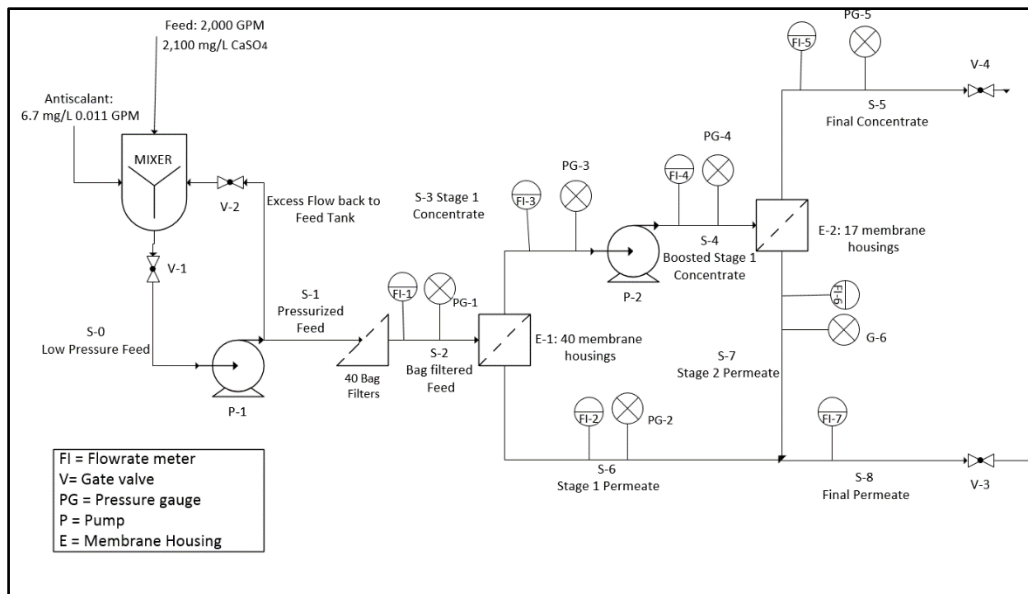

Figure 3: Nanofiltration Unit Full Scale Design

Table 4: Nanofiltration Stream Attributes

Stream	Stream Information	Vol Flow (GPM)	P (psi)	T (F)	Total (lb/min)	H2O (lb/min)	CaSO4 (lb/min)	Concentration CaSO4 (ppm)
S-0	Feed from Well	2000	0	77	16721	16690	31	1861
S-1	Feed to Prefilter	2000	90	77	16721	16690	31	1861
S-2	Feed to First Stage NF Housing Units	2000	90	77	16721	16690	31	1861
S-3	Concentrate from First Stage	800	80	77	6707	6676	30.8	4614
S-4	Feed to Second Stage NF Housing Units	800	116	77	6707	6676	30.8	4614
S-5	Concentrate from Second Stage	320	107	77	2701	2670	30.5	11436
S-6	Permeate from First Stage	1200	0	77	10014	10014	0.3	27
S-7	Permeate from Second Stage	480	0	77	4006	4006	0.3	67
S-8	Total Permeate	1680	0	77	14020	14020	0.5	47



## 6.2 Hot Process

The hot process is a novel idea that utilizes the retrograde solubility of calcium sulfate to achieve proper precipitation and separation. Once heated to approximately 200 C, the solubility of calcium sulfate decreases to a point such that just under 250 ppm of calcium sulfate would be left in the desired product stream, provided the crystallized sulfate is separated.

As shown in Figure 4, the feed is pressurized to 15 times atmospheric pressure via pump P-11 and sent through heat exchanger H-11 with a log mean temperature difference of 15 degrees Fahrenheit. For the process at the Sierrita mine, a boiler would need to be added for steam use in the water treatment process, or a direct fired heater could be used with natural gas. The water, stream S-12, would then run through a series of 5 agitated crystallizers, V-11 through V-15 with the number determined from required residence time based on experimental results. This allows for a residence time of 60 minutes. Multiple agitated vessels are needed in order to adequately allow for crystallization, because that is the reasonable size limit for shop-fabricated vessels.

The effluent from the final crystallizer is sent into an array of hydrocyclone banks represented by L-11, which apply centrifugal force to separate the heavy, precipitated calcium sulfate into a slurry mixture. The treated water, stream R-11, is forced out the top, and this stream is recycled back to H-11, where a clean outlet product stream, S-14, that has been cooled by the inlet fluid is obtained. A small portion of steam, S-13, will also be injected to maintain the desired temperature difference in the heat exchanger. A small part (approximately 10%) of the slurry would be sent back into the first crystallizer for seeding in stream R-12, whereas the rest of the slurry, W-12, would proceed to a condenser, H-12, in order to reduce it below the boiling point of water. If desired, this could simply be flashed to atmospheric as well. The attributes for each stream can be viewed in Table 5.

In order to size the hydrocyclone, the average size of calcium sulfate particles in microns was determined with a light microscope. The effluent slurry from the bottom of the hydrocyclone banks would also be deposited into an evaporation pond.

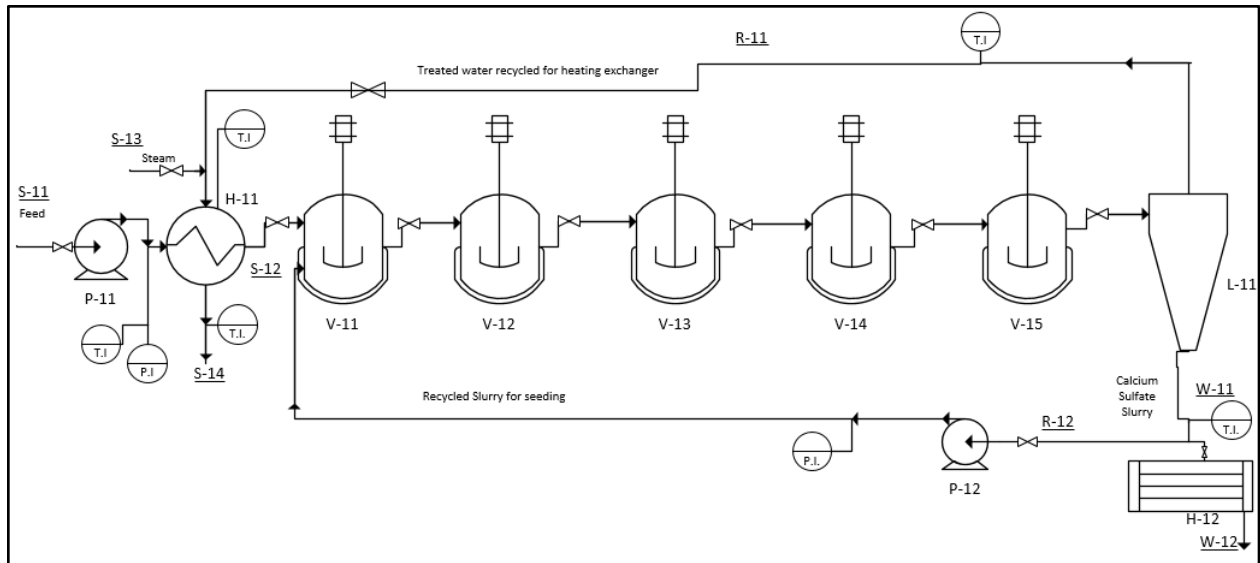

Figure 4: Hot Process Unit Full Scale Design

Table 5: Hot Process Stream Attributes

Stream	Stream Information	Vol Flow (gpm)	P (atm)	T (F)	M Flow (lb/min)	H <sub>2</sub> O Flow (lb/min)	CaSO <sub>4</sub> Flow (lb/min)	SO <sub>4</sub> wt% (ppm)
S-11	Feed	2000	1	68	16730.39	16695.26	35.13	1500
S-12	Feed outlet from heat exchanger	2000	15.3	392	16730.39	16695.26	35.13	1500
S-13	Steam feed	29.78	15.3	407	248.67	248.67	0	0
<b>S-14</b>	<b>Product from heat exchanger</b>	<b>2015.87</b>	<b>1</b>	<b>83</b>	<b>16832.67</b>	<b>16902.741</b>	<b>5.86</b>	<b>248</b>
R-11	Recycle of treated water to heat exchanger	1986.09	15.3	392	16584	16578.14	5.86	254
R-12	Slurry recycle to first crystallizer	1.39	15.3	392	14.64	11.71	2.93	143,000
<b>W-11</b>	<b>Slurry stream from hydrocyclone</b>	<b>13.91</b>	<b>15.6</b>	<b>392</b>	<b>146.39</b>	<b>117.11</b>	<b>29.28</b>	<b>143,000</b>
W-12	Outlet from condenser	12.51	1	212	131.75	105.40	26.35	143,000

### 6.3 Waste Disposal

WPS came to the decision that a solar pond would be the most effective method for removing the unrecovered water from both of these particular waste streams. Decanting the concentrate and sending it through the hot process was considered, but lab tests with the nanofiltration concentrate showed that the antiscalant greatly hindered the effectiveness of the

hot process. Additionally, the capital and energy costs associated with a reduced capacity hot process would exceed that of an evaporation pond.

While recovery is of high priority, the 90% achievable through nanofiltration comes at a price far lower than that of recovering the last few percent. This evaporation pond could have much of the costs already covered just by being placed into a corner of the existing tailings pond, Figure 2 being a reference for that. A geomembrane lined pond of approximately 923ft on each side would be needed, and an air cannon placed at the center of the pond could potentially evaporate up to 50% of the water at a lower cost than just using a larger pond. The further concentrated brine of this pond could then be sent to a smaller finishing pond for final disposal.

For the hot process, the pond would need to be approximately 345ft on either side, double lined with a simple geomembrane. A finishing pond that is approximately 20% of the area would be incorporated for the concentrated brine to move to over time.

With a net evaporation of approximately 100 in/yr in the area<sup>18</sup>, this was determined to be the ideal method for dealing with the un-recovered water for both processes.

## **7.0 FULL-SCALE ECONOMIC ANALYSIS**

The full scale economic analyses for both the hot process and nanofiltration are presented below in Tables 6 and 7. Capital cost is representative of the sum of the equipment purchase costs, with a lang factor of 4 chosen to represent the associated installation and manufacturing costs (if needed to be done on site). The yearly operating costs represent any maintenance and operation costs that encompass the day-to-day operation of each system, as well as any replacement costs for process equipment: the replacement rate for nanofiltration membranes is approximated at 13% per year, per estimates from the software “Dow Water & Process Solutions:WAVE” model. All hot process vessels and pipelines will be made of 304SS.

Table 6: Hot Process Cost Breakdown

Item:	Cost:
Shell-and-Tube Exchanger	\$400,000
25000gal Crystallizers (x5)	\$150,000
Feed and Recycle Pumps	\$10,000
Vessel Agitator (x5)	\$25,000
Steam Boiler	\$25,000
Underflow Condenser	\$20,000
Hydrocyclones	\$140,000
Evaporation Ponds Lining	\$13,300
Lang Factor	4
<b>Total Capital Cost</b>	<b>\$3,133,200</b>
Steam Costs	\$523,147
Operator Costs	\$200,000
Pumping Costs	\$26,300
Agitation Costs	\$16,000
Maintenance Costs	\$156,660
<b>Yearly Operating Costs</b>	<b>\$922,107</b>
<b>30-Year NPV</b>	<b>-\$11,825,823.82</b>
Cost Per 1000gal treated (30yr)	\$1.19
Cost Per 1000gal treated (5yr)	\$1.66

Table 7: Nanofiltration Cost Breakdown

Item:	Cost:
Nanofiltration Elements	\$273,600
Membrane Housings	\$114,000
5-Micron Bag Filters	\$146
Bag Filter Housings	\$35,000
Pumps	\$40,000
Piping/Instrumentation	\$100,000
Evaporation Pond	\$75,900
Installation	\$281,400
Evaporator Cannon	\$15,000
Lang Factor	4
<b>Total Capital Cost</b>	<b>\$3,695,074</b>
Membrane Replacement	\$35,600
Bag Filter Replacement	\$1,700
Pumping Costs	\$12,400
Operator Costs	\$200,000
Antiscalant Costs	\$189,200
Maintenance Costs	\$50,000
Evaporator Cannon Costs	\$21,000
<b>Yearly Operating Costs</b>	<b>\$619,970</b>
<b>30-Year NPV</b>	<b>-\$9,539,482</b>
Cost Per 1000gal treated (30yr)	\$0.96
Cost Per 1000gal treated (5yr)	\$1.52

## 8.0 BENCH SCALE OPERATION

In order to test the viability of the identified processes, two bench scale systems were constructed: a single crystallization bomb vessel to simulate the hot process, and a six membrane element nanofiltration unit that is representative of a single stage housing.

### 8.1 Design

The designs for the nanofiltration and hot process systems are shown below in Figures 5 & 7, respectively. The basis for these designs was to generate the smallest bench-scale footprint possible while having the requisite materials to comfortably approach target conditions without creating significant strain on the process equipment. Pictures demonstrating what these bench scales looked like when completed are also shown in Figures 6 and 8.

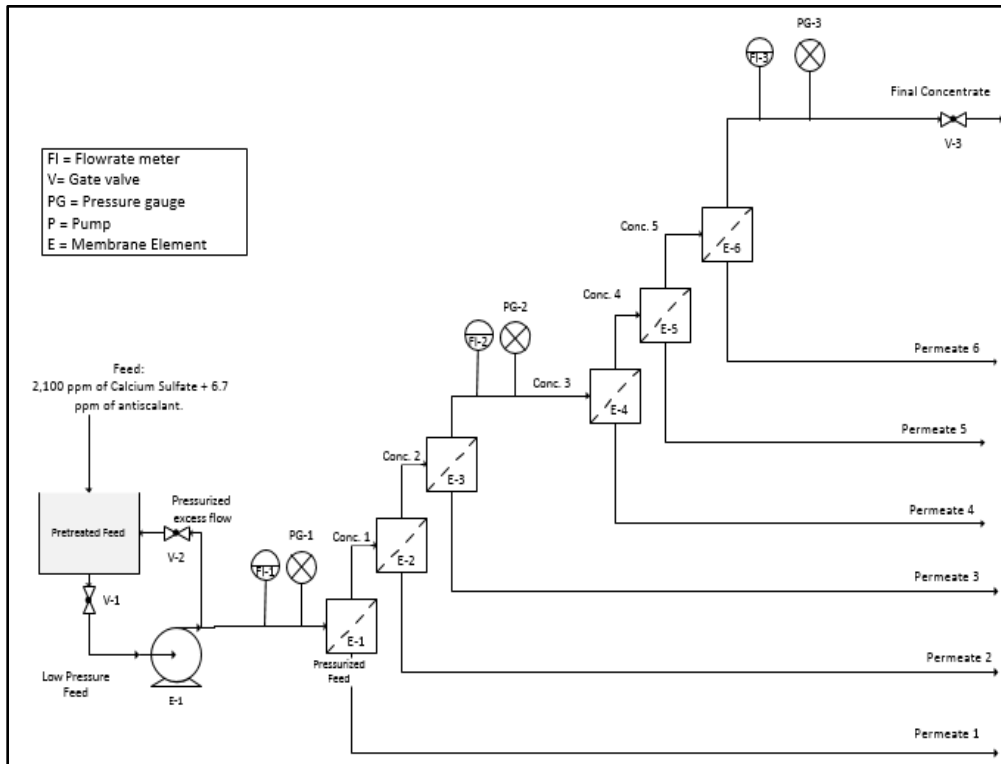

Figure 5: Nanofiltration Unit Bench Scale



Figure 6: Single and Multiple NF Membrane Bench Scale

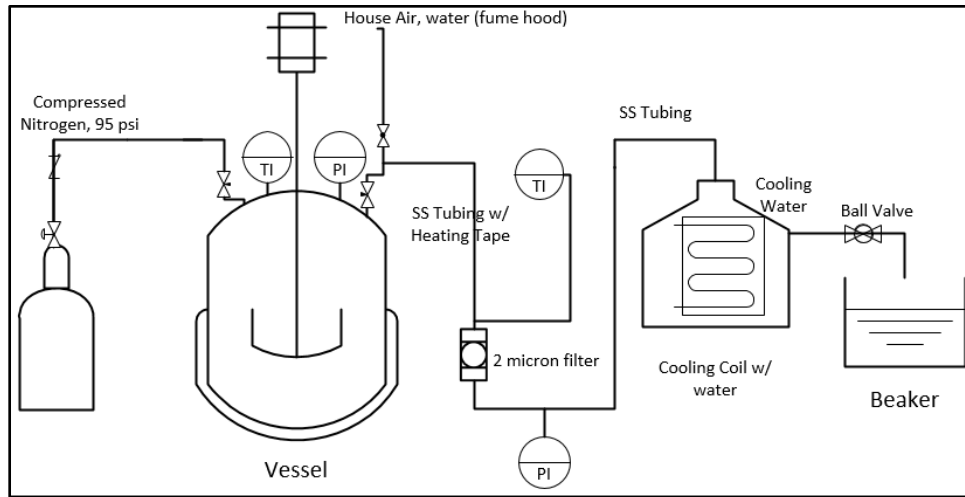

Figure 7: Hot Process Bench Scale Design



Figure 8: Hot Process Bench Scale

### 8.1.1. Nanofiltration:

The experimental unit consisted of six 2x12 inch pressure vessels made of specialized PVC. These pressure vessels were connected in series, each one of them containing a 1.8 inch membrane element.<sup>19</sup> The unit also includes a centrifugal pump<sup>20</sup> used to force pretreated feed through the membrane housings at a controlled pressure of 90 psig. Pretreatment takes place in a 32 gallon tank and involves the addition of a phosphonic acid-based antiscalant<sup>21</sup> to the feed water at a concentration of 10 ppm, which is the maximum typical dosage recommended by its

manufacturer. Part of the pressurized feed is sent back to the feed tank to control flow through the unit. The rest of the feed enters the first pressure vessel. The concentrate becomes the feed for the second pressure vessel, and so on, until the final concentrate exits the sixth vessel. The permeate exiting each vessel joins subsequent permeate streams exiting the other vessels, reaching a recovery of approximately 60%. The piping is made of stainless steel for sections dealing with a high pressure fluid, and plastic hosing for sections whose pressure rating is close to atmospheric. Miscellaneous fittings and connectors were necessary to join different pieces of equipment.

### **8.1.2. Hot Process**

A 1.2L pressurized reactor was utilized for treating water saturated with gypsum as a batch process.<sup>22</sup> This reactor has both a built in heating coil and agitator, as well as lines to allow for pressurization of the vessel. The materials used in this process include a ¼ inch SS tubing, 3 ft heating tape, glass fiber insulation, a globe and needle valve and a ¼ inch metal coil. A nitrogen tank with a regulator was used to pressurize the vessel to 95 psig for a number of runs. To operate as a continuous process, the nitrogen tank was replaced with a feed line and a pump.

### **8.2 Safety Considerations**

In the nanofiltration unit, rupture of pressurized lines or vessels, leaking connections, improperly secured tubing, pump cavitation, membrane housing leaks or rupture, and improperly calibrated gauges could potentially occur. Gauges and flow meters should be monitored at all times to ensure pressure and flow conditions are safe. On the other hand, for the hot process, loose connections, tubing and pipes not properly clamped or secured, leaks in the crystallizing vessel, pressurized gas leaks, and pressurized fluid leaks are all potential hazards that may occur. Burn hazards associated with contact with heated vessel surfaces is also important to be aware of.

### **8.3 Safety Guidelines**

General safety procedure entails that anyone working around either process should have the fume hood in the proper position (or be outside, open to the atmosphere), and for the blast shield to be covering the pump, motor and membrane housing. In the event of process upsets, shutdown procedure entails turning off all electrical equipment safely, opening all safety valves, and evacuating the lab, if anything were to happen. Insulated gloves should be worn when

working with an active hot process, and standard lab PPE should always be worn when around either unit.

### 8.4 Experimental Results and Discussion

#### Nanofiltration:

Table 8: Nanofiltration data for varying pressure and flow

	Varying Pressure at 0.35 GPM					Varying Flowrate at Constant Pressure				Varying Pressure at 0.5 GPM		
<b>Controlled Variables</b>												
Feed Flowrate (GPM)	0.35	0.35	0.35	0.35	0.35	0.5	0.75	1	1.5	0.5	0.5	0.5
Feed Pressure (psig)	<b>30</b>	<b>60</b>	<b>90</b>	<b>120</b>	<b>150</b>	90	90	90	90	60	90	120
<b>Results</b>												
Concentration of Sulfate in Permeate (ppm)	173	86	85	91	88	61	62	66	55	86	83	81
% Salt Rejection	89.7%	94.9%	95.0%	94.6%	94.8%	96.4%	96.3%	96.1%	96.7%	94.9%	95.0%	95.2%
Flux (GPD/sqft)	<b>12.0</b>	<b>25.0</b>	<b>32.0</b>	<b>48.8</b>	<b>56.3</b>	<b>37.8</b>	<b>40.2</b>	<b>41.1</b>	<b>43.0</b>	<b>25.6</b>	<b>39.4</b>	<b>51.8</b>

Table 9: Reverse Osmosis data for varying pressure at constant flow

Reverse Osmosis Recycle Test	Varying Pressure at a Constant Flowrate				
<b>Controlled Variables</b>					
Flowrate of Feed (GPM)	0.35	0.35	0.35	0.35	0.35
Feed Pressure (psig)	<b>90</b>	<b>120</b>	<b>150</b>	<b>180</b>	<b>200</b>
<b>Results</b>					
Concentration of Sulfate in Permeate (ppm)	25	22	21	20	20
% Salt Rejection	98.4%	98.6%	98.7%	98.7%	98.7%
Flux (GPD/sqft)	<b>22.9</b>	<b>30.7</b>	<b>37.7</b>	<b>44.4</b>	<b>22.9</b>

Table 10: Nanofiltration 60% Recovery test with antiscalant

Nanofiltration 60% Recovery Test with Antiscalant Data							
Time (min)	0	10	21	30	43	56	72
Concentration Factor	<b>1</b>	<b>1.11</b>	<b>1.25</b>	<b>1.36</b>	<b>1.67</b>	<b>1.94</b>	<b>2.50</b>
<b>Concentration (ppm)</b>							
Feed	1695	1950	2186	2493	3086	3812	3495
Permeate	<b>76</b>	<b>84</b>	<b>94</b>	<b>105</b>	<b>127</b>	<b>145</b>	<b>151</b>
Concentrate	1828	2339	2748	3157	3914	4599	4303
% Salt Rejection	96%	96%	96%	96%	96%	96%	96%
<b>Measured Flowrates (GPM)</b>							
Feed	0.47	0.46	0.50	0.49	0.49	0.50	0.48
Permeate	0.094	0.093	0.093	0.091	0.088	0.086	0.079
Concentrate	0.38	0.37	0.41	0.41	0.40	0.41	0.41
Flux (GPD/sqft)	<b>34.61</b>	<b>34.45</b>	<b>34.25</b>	<b>33.42</b>	<b>32.67</b>	<b>31.84</b>	<b>29.17</b>



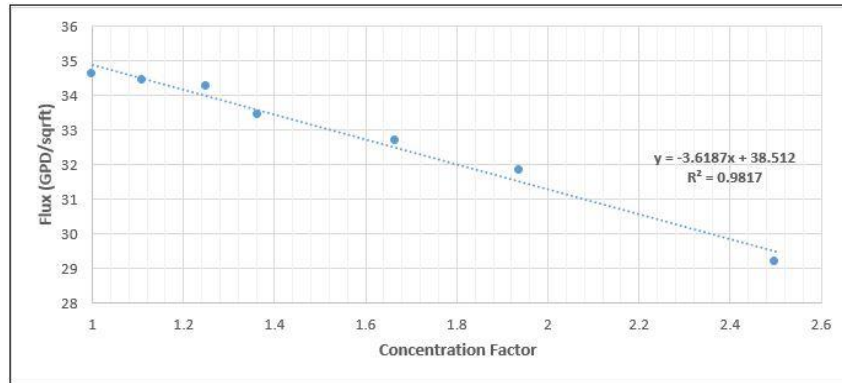

Figure 9: Flux vs. Concentration Factor for Nanofiltration Membranes

Table 10: Six Membrane Recovery Test

	First Stage Simulation	Second Stage Simulation
<b>Total flowrate (GPM)</b>	0.97	0.90
<b>Feed Pressure (psi)</b>	90	113
<b>Permeate Concentration (ppm)</b>	<b>77.9</b>	<b>91.3</b>
<b>% Salt Rejection</b>	94.23%	97%
<b>Permeate Recovery (%)</b>	<b>60.9%</b>	<b>65%</b>
<b>Flux (GPD/ft<sup>2</sup>)</b>	36.7	36.5

First, an experiment was conducted to determine the effects of pressure and flowrate changes on flux rates and salt rejection with a saturated calcium sulfate solution using a single membrane element. In this experiment, the concentrate and permeate were both recycled to the feed tank to maintain a steady state concentration. Flux rates at varying pressure were investigated at flowrates of 0.3 and 0.5 gpm. The flux rate was also analysed for flow rates between 0.3 and 1.5 gpm at 90 psig. The results, as can be seen in Table 8, suggest that salt rejection increases at higher pressures and that flux decreases with increasing flowrate. Similar tests were conducted with an RO membrane in the same setup, and we confirmed that RO would also work well. However, we have no need to clean the water to such low concentrations (nearly 0ppm), so we decided to move forward with just the cheaper nano membranes.

The second experiment type was configured similar to the first except the permeate was captured in a separate vessel until 60% of the initial feed had been recovered. To accurately examine the effectiveness of nanofiltration, conditions for this experiment were set to match that of the full scale design based off results from WAVE design software from DOW. The best manner to achieve this is by maintaining a similar flux rate through the membranes in both bench

and industrial scale designs. A single membrane element has a surface area of 3.9 ft<sup>2</sup>, thus, in order to keep a similar flux, a flowrate of 0.5 gpm is necessary for this experiment. Through the flowrate and concentration information gathered, a relationship between the flux rate and the concentration factor were determined, as seen in Figure 9, to aid in the design of the 6 membrane setup and predict the results of the final bench scale design. This setup was initially run without antiscalant; however this was simply to confirm the need for antiscalant and simulate significant fouling of the membrane.

Final experimentation was conducted with the six membrane arrangement illustrated previously in Figure 9 with the purpose of simulating the results of the full scale design. Feed was processed with a recovery of approximately 60% and the permeate and concentrate streams were collected. Concentrate from the first run of the system was then fed through the system once again to simulate the second stage of the full scale design and achieve a combined recovery of 86.5%, similar to what was predicted by WAVE. From the results of this experiment, which can be seen in Table 10, it was determined that the antiscalant would be effective at the high concentrations present in the second stage of the nanofiltration unit, that 84% overall recovery was entirely reasonable for this application, and that the results of the bench scale agreed with the WAVE simulation for the full scale design.

### **Hot Process:**

The most successful experiment for the hot process accomplished an 88.4% reduction in concentration of sulfate in a run at 200°C for 2.5 hours with a 98% recovery. The system was modified to run a variety of inline filters while insulated, in order to minimize contamination and resolubilization due to heat loss. These inline filters were used in order to model the separation of calcium sulfate particulates at a small scale, instead of hydrocyclones. The largest concern with the hot process is crystallization time, as more residence time is needed the longer it takes for calcium sulfate crystals to agglomerate. This means more vessels (and/or larger vessels) to achieve appropriate crystallization would add more costs to the process. WPS determined that a residence time of approximately 60 minutes at temperature, in addition to 50 minutes that the process took to heat up to, met requirements at the bench scale based on experimentation, which is shown in Figure 11. Further data is to be collected on this process. Additionally, as seen in Figure 10, WPS used a light microscope in order to take pictures of the crystals formed from various experiments compared to 75 micron wire, as this was essential in sizing and cost

estimating the hydrocyclones for the full scale design. These indicate that the separation of the calcium sulfate will be difficult due to small crystal size.

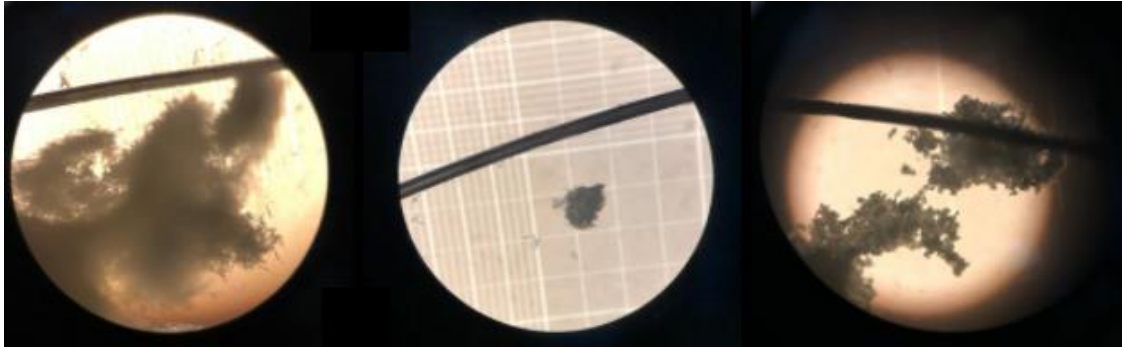

Figure 10: Light Microscope Images of Crystal Agglomeration

Table 11: HP sulfate reduction vs. time

Hot Process Sulfate Reduction over time on Prepared Solution at 200 C					
Time temperature Held (min)	30	60	90	120	150
Feed Concentration (ppm)	1500	1500	1500	1500	1500
Exit Concentration (ppm)	479	233	188	185	174
Reduction (%)	68.1%	84.5%	87.5%	87.7%	88.4%

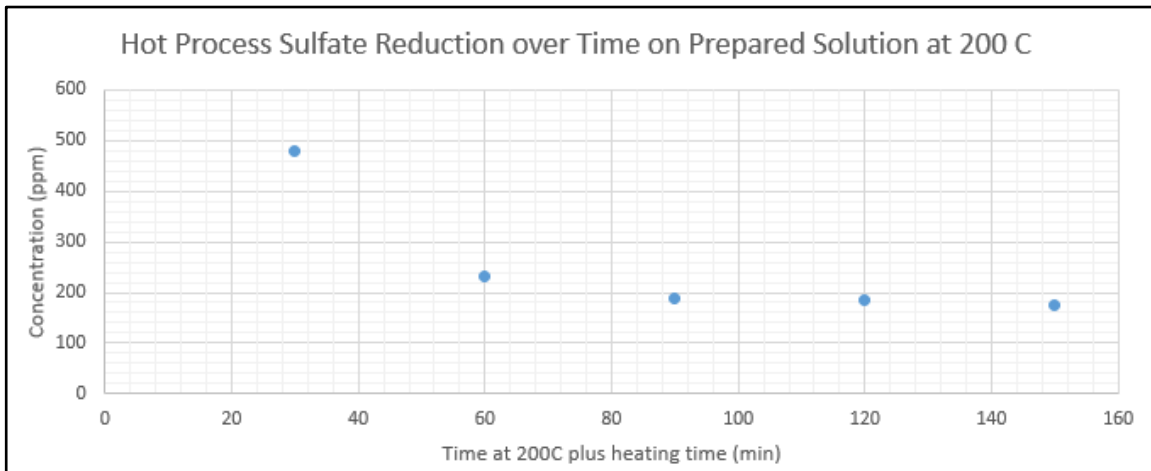

Figure 11: HP sulfate reduction vs time at 200°C

**Discussion:**

Both the hot process and nanofiltration achieved sulfate concentration reduction to levels less than 250 ppm, with the batch hot process recovering almost all of the water supplied. The single nanofiltration membrane achieved higher permeate flow than predicted, and the multi-membrane setup performed as expected, according to WAVE.

Although the hot process seems to be the clear choice based off recovery, there are issues with it: residence times on the batch scale of the hot process are prohibitive, and continuous scale testing is still in progress at the time of writing. As such, WPS is currently unable to ascertain the impact and extent of fouling over time on a continuous hot process.

## **9.0 ENVIRONMENTAL CONSIDERATIONS**

The composition of the final concentrate stream can be as low as 80% water if the hot process is selected, or over 98% if a nanofiltration system is employed, which implies a relatively large amount of brine will be produced per time unit. With regards to the final handling of the brine produced, a variety of alternatives have been proposed, such as further concentrating it by means of solar evaporation via ponds and evaporator cannons.<sup>13</sup> The end result of these implementations would be solid gypsum that eventually would be removed from the ponds. The solid gypsum produced could potentially be sold to local industries for wallboard production and other uses. Otherwise, the gypsum generated could be landfilled as long as the pertinent local, state, and national authorities permit it.

An ideal process for this task would result in 100% usable water with no liquid byproduct. While the nanofiltration process reaches 84% recovery, it still results in a waste stream of approximately 320 gpm that needs to be treated. Approximately 120 gpm of this can be removed by concentrating the permeate with feed. In order to reduce the environmental impact of this brine, it was determined that 200 gpm of concentrated effluent could be sent to an evaporation pond to allow for passive treatment of the waste, the economics of which were presented previously. The cost added to the overall project was several cents per 1000 gallons unto the existing cost.

On the other hand, the hot process maximizes water recovery to 99% of the initial feed. In fact, the brine stream coming out of this process would be 14 gpm, 20% of which corresponds to precipitated and dissolved solids. Implementing the hot process would significantly reduce the amount of concentrated brine, thus, reducing the dimensions of the constructed evaporation pond.

One of the most important characteristics that both the hot process and nanofiltration systems possess is that they do not generate any byproducts.

## **10.0 REGULATIONS**

Regarding regulations on the acceptable level of calcium sulfate in water, the Arizona Department of Environmental Quality (ADEQ) does not have any specific constraints on the levels of calcium sulfate present in drinking water, opting instead to defer to appropriate EPA national standards, if possible. Per the EPA's page on Secondary Drinking Water Standards, sulfate is one of fifteen contaminants that have non-mandatory quality standards established. While optional, these standards are established as a benchmark for communities to sustain current levels of aesthetic water quality, referring to aspects such as taste and odor.<sup>3</sup> The secondary Maximum Contaminant Level (MCL) associated with sulfate is 250 mg/L (250 ppm), with the noticeable effects above that concentration being a salty taste, or laxative effects.<sup>23</sup>

### **10.1 Permitting**

Due to the presence of the Sierrita Mine's tailings pond, an Aquifer Protection Permit (APP) is required. The APP demonstrates that the facility does not discharge a pollutant directly into an aquifer, land surface or a vadose zone. The mine also displays a compliance with the ADEQ standards as well as the financial capabilities for the life of the facility, closure and post closure. Currently the Freeport-McMoran Sierrita mining operations are operating under an APP issued on June 29, 2007.<sup>24</sup>

## **11.0 CONCLUSIONS AND RECOMMENDATIONS**

Based on the results of current tests and preliminary industrial-scale design, the most economically viable options proposed are the hot process and the multistage nanofiltration systems, each having costs of \$1.19 and \$0.96 per 1000 gallons treated, respectively. Both have demonstrated on a limited bench scale the ability to reduce sulfate concentration below 250 ppm.

Although the hot process potentially produces less waste than nanofiltration, it is still an unproven process that has never been built on an industrial scale before. It is also not known how the heat exchanger and crystallizers in the full-scale hot process will be affected by sulfate deposition and fouling, due to a lack of data on calcium sulfate with regards to operation of the aforementioned unit operations. Regardless, this process must be further optimized through further testing on laboratory and pilot plant scales, which could help address these concerns and potentially determine the most economical process.

Based on the economics and data presented, both the nanofiltration and hot process are suggested as viable solutions for reducing sulfate levels in the aforementioned mine water, with the deciding factor being whether or not a client wants to maximize water recovery at additional expense.

## 12.0 ACKNOWLEDGEMENTS

WPS would like to acknowledge Freeport-McMoran for granting a tour of the Sierrita Mine for which this solution was based on; the Water Quality Lab at the University of Arkansas for their assistance in testing water samples, and the Honors College and Arkansas Alpha chapter of Tau Beta Pi at the University of Arkansas for awarding research travel grants to team members, which made site visits possible. Furthermore, WPS profoundly thank Mr. Robert Cross M.S. and Dr. Tammy Lutz-Rechtin at the University of Arkansas, as well as Devin Hazlett at DOW Chemical. Most importantly, WPS would like to express deep gratitude to George Fordyce for all of his design wizardry in bringing both of WPS processes to life, as well as Mr. James Barron for his assistance and input throughout this semester.

## 13.0 REFERENCES

1. Bowell, R. J. (2004): A review of sulphate removal options for mine waters. – In: Jarvis, A. P., Dudgeon, B. A. & Younger, P. L. (eds): mine water 2004 – Proceedings International Mine Water Association Symposium 2. – p. 75-91, 6 fig., 7 tab.; Newcastle upon Tyne (University of Newcastle).
2. Ritsema, C. J., & Groenenberg, J. E. (1993). TRANSFORMATIONS IN A POTENTIAL ACID SULFATE SOIL. Pyrite Oxidation, Carbonate Weathering, and Gypsum Formation in a Drained Potential Acid Sulfate Soil, 968-976. Retrieved January 20, 2018, from <https://dl.sciencesocieties.org/publications/sssaj/pdfs/57/4/SS0570040968>.
3. Secondary Drinking Water Standards: Guidance for Nuisance Chemicals. Environmental Protection Agency (2017, March 08). Retrieved March 06, 2018, from <https://www.epa.gov/dwstandardsregulations/secondary-drinking-water-standards-guidance-nuisance-chemicals>
4. Kuthadi, S. K. (2014). Laboratory Scale Study of Calcium Sulfate Hydration Forms. Retrieved February 20, 2018, from <https://digitalcommons.wku.edu/cgi/viewcontent.cgi?article=2471&context=theses>
5. *Kinetics of gypsum nucleation and crystal growth from Dead Sea brine*, Reznik Itay J., Gavrieli Ittai and Ganor Jiwchar
6. NMSU. (n.d.). Task 2: Sulfate Removal from Mine Impacted Waters. Retrieved March 06, 2018, from <https://iee.nmsu.edu/university-tasks/task-2-sulfate-removal-from-mine-impacted-waters/>

7. FREEPORT-MCMORAN. (n.d.). FREEPORT-MCMORAN IN ARIZONA: Connecting the Past, Present and Future. Retrieved from [https://www.fcx.com/sites/fcx/files/documents/fast\\_facts/AZ\\_brochure2014.pdf](https://www.fcx.com/sites/fcx/files/documents/fast_facts/AZ_brochure2014.pdf)
8. Frank, G., D. Knöfel, F. Wirsching: in Harnisch, H., R. Steiner, K. Winnacker (Eds.): *Chemische Technologie*, Vol. 3, 4th ed., p 214, Carl Hanser, München, Wien, 1983.
9. Mottley, M. G. (2011). Water Reuse for Managing Impacted Water At Sierrita. Retrieved March 6, 2018, from [https://www.mtech.edu/mwtp/conference/2011\\_presentations/Martha%20Mottley.pdf](https://www.mtech.edu/mwtp/conference/2011_presentations/Martha%20Mottley.pdf)
10. Google Earth. (n.d.). Retrieved March 06, 2018, from <https://earth.google.com/web/@31.84649342,-111.04528866,1057.00299443a,7672.2081475d,35y,-0.00000002h,3.40484728t,-0r>
11. Muyzer, G. (2008). The ecology and biotechnology of sulphate-reducing bacteria. *Nature Reviews: Microbiology*, 6, 441-451. doi:10.18411/a-2017-02
12. *Treatment of Sulfates in Mine Effluent* (Publication). (2003, October). Retrieved February 28, 2018, from International Network for Acid Prevention website: [http://www.inap.com.au/public\\_downloads/Research\\_Projects/Treatment\\_of\\_Sulphate\\_in\\_Mine\\_Effluents\\_-\\_Lorax\\_Report.pdf](http://www.inap.com.au/public_downloads/Research_Projects/Treatment_of_Sulphate_in_Mine_Effluents_-_Lorax_Report.pdf)
13. Faria, J. I., P.E. (n.d.). *Solar Evaporator Solar Evaporator for Integrated on for Integrated on-Farm Drainage Management (IFDM) Farm Drainage Management (IFDM) System at Red Rock Ranch, System at Red Rock Ranch, San Joaquin Valley, California* [PDF]. San Joaquin Valley, California: Department of Water Resources (DWR), San Joaquin Distric.
14. Garrett, D. E. (1989). *Chemical engineering economics*. Springer.
15. Gumerman, R. C., Culp, R. L., Hansen, S. P., & Lineck, T. S. (1979). *Estimating water treatment costs*. Cincinnati, OH: Environmental Protection Agency, Office of Research and Development, Municipal Environmental Research Laboratory.
16. Peters, M. S., Timmerhaus, K. D., & West, R. E. (2003). *Plant Design and Economics for Chemical Engineers*. Boston: McGraw-Hill.
17. Turton, R., Bailie, R. C., Whiting, W. B., Shaeiwitz, J. A., & Bhattacharyya, D. (2015). *Analysis, Synthesis, and Design of Chemical Processes*. Pearson Education.
18. Evaporation Stations. (n.d.). Retrieved March 15, 2018, from <https://wrcc.dri.edu/htmlfiles/westevap.final.html>
19. M-N1812A5. (n.d.). Retrieved March 06, 2018, from <https://www.wateranywhere.com/1-8-x12-36-gpd-nf-50-rejection-nanofiltration-membrane/>
20. Procon Pump Brass w/ .188" Double Flat Drive 125 GPH 3/8" NPT - 250 PSI Relief Valve. (n.d.). Retrieved March 06, 2018, from <https://www.freshwatersystems.com/p-8242-procon-pump-brass-w-188-double-flat-drive-125-gph-38-npt-250-psi-relief-valve.aspx>
21. ChemTreat. (n.d.). ChemTreat Safety Data Sheet. Retrieved from [http://files.dep.state.pa.us/Water/Wastewater%20Management/EDMRPortalFiles/Chemical\\_Additives/MSDS/997.pdf](http://files.dep.state.pa.us/Water/Wastewater%20Management/EDMRPortalFiles/Chemical_Additives/MSDS/997.pdf)
22. Parr. (n.d.). SAFETY in the Operation of Laboratory Reactors and ... Retrieved March 6, 2018, from <http://www.ccmr.cornell.edu/wp-content/uploads/sites/2/2015/11/ParrReactorSafetyInfo-230m.pdf>
23. Wells and Borings. (n.d.). Retrieved March 06, 2018, from <http://www.health.state.mn.us/divs/eh/wells/waterquality/sulfate.html>
24. Chauhan, V. (n.d.). *Arizona Environmental Department of Quality Draft Fact Sheet* [PDF]. Phoenix, Arizona. [https://www.azdeq.gov/sites/default/files/factsheet\\_aps.pdf](https://www.azdeq.gov/sites/default/files/factsheet_aps.pdf)

WERC 2018

## Task 2: Sulfate Removal from Mine Impacted Waters

Woo Pig Sulfate (WPS) Team

Department of Chemical Engineering

University of Arkansas, Fayetteville, AR

I have had the privilege of reviewing WPS Team's paper on "Sulfate Removal from Mine Impacted Waters". In my work role at Dow Chemical Co (soon to be Corteva Agrosience), I work as a Senior Improvement Engineer doing project improvement work and providing Technology consulting to our Manufacturing facilities. I have a background in Chemical Plant manufacturing operations, Process Safety, Process Automation, & Capital Project Implementation; I also have a California Professional Engineering License in Chemical Engineering.

Overall the report generated by Ben's Team demonstrates good research and understanding of the basic process technologies, fairly complete evaluation of process alternatives, and captures a solid process design to treat mine water high in Sulfates.

Some observations and comments on the report:

- Mention of Solar Evaporation Ponds were in the Executive Summary and in the Full Scale description. This is an older Technology that is being phased out in many areas of the chemical industry. You may need to evaluate a more environmentally friendly way to manage the concentrated Sulfate water from your full scale designed process. In fact, the permitting process may require additional treatment for the concentrate stream depending on the state you are in.
- You saw some corrosion and issue with your filters in the Hot Process experiments, and ended up using all Stainless Steel equipment after that. As you scale up processes from mini-plant to full scale size, materials of construction become increasingly important and impact the cost significantly. More study here and possible use of corrosion coupons to test different metals may be needed.
- As you look at the crystallization step in the Hot Process, you may have to understand the impact of other salt impurities dissolved in the mine water. Your experiments were done using just Calcium Sulfate, but what happens when other salts are present? Does this impact the way crystals are formed and how much residence time you need in the reactor? It could get better with extra impurities, but you don't know until you test it.



- With your Nanofilters, how long will the filters last before they need to be changed out with new filter elements? That is difficult to measure in the lab scale, but may become significant as you scale up to large units. This will impact the cost of operating that process in the full scale system.
- Some quality considerations to evaluate for the full scale Nanofiltration system. What kind of quality control would you need? How often would you take samples and where? Would you consider use of on-line analyzers to measure product quality, or just rely on manual samples? Is the analytical equipment part of the overall cost?
- Scale-up of the Hot Process has a number of issues. As you mentioned at the end of the report, fouling in the exchanger will be a challenge. My experience in working with water slurries is the fluid velocity is critical in keeping the solids suspended rather than falling out in the wrong places. As I mentioned before, materials of construction and corrosion may also be big factor, and normal Stainless Steel may not be good enough; higher alloys are available but costly. I work around plants that are built in mostly Nickel alloys, so I know how expensive that is.
- I like the use of the Hydrocyclone, and they are fairly cheap to purchase and operate. I have run that unit in one of our processes here at Dow. You will need to do a lot of study and work on the design based on the particle size you are expecting out of the Hot Process crystallizers. Particle size and particle density compared to water are key variables that design.
- 6.3 Safety Considerations:
  - For the Hot Process, burn hazard is always something you need to consider when operating at temperatures above 150 F.
  - May want some discussion on what protective gear (gloves, goggles, etc) you need while doing the lab scale work.

The report by the WPS team for WERC 2018 is very well thought out and researched. I really like the team's emphasis on reduced process complexity and lower cost to operate. I was also impressed with the Team's resourcefulness to use a wide variety of sources of information as part of the basis for the report.

I enjoyed doing this review, and probably learned a little bit about Sulfate removal treatment in water streams.

Sincerely,

Barry Swan, PE  
Sr. Improvement Engineer  
Dow Chemical Company  
Pittsburg, California

Department of Public Utilities  
Incorporated County of Los Alamos, New Mexico  
1000 Central Ave., Suite 130  
Los Alamos, New Mexico 87544

March 13, 2018

Project Woo Pig Sulfate Team  
Ralph E. Martin Department of Chemical Engineering  
University of Arkansas  
Fayetteville, AR

RE: Evaluation of Task 2; Sulfate Removal from Mine Impacted Waters, WERC 2018

As requested I have reviewed your research paper on Sulfate removal from mine impacted waters and am pleased to offer the following observations;

1. Equation 1 and 2 problems. I have a hard time believing the pyritic oxidation reaction generates  $\text{CO}_{4(g)}$ . Carbon tetroxide, if it exists at all would be a highly unstable intermediate compound briefly found during the progression of another reaction. The equations are also not balanced. Finally, I believe your dihydrate of calcium sulfate (gypsum) formula is wrong; it should have two waters attached to a single calcium sulfate, not the other way around.
2. While I think I understand why you used the standard you did, 250 mg/l for sulfate is a secondary, aesthetic standard for drinking water and is a somewhat high bar for mine discharges. Has Arizona DEQ established such a standard for mine process water discharges through an NPDES permit or the state's Aquifer Protection Permit? Considerable money could be saved through blending treated with non-treated, or partially treated process water to meet a lower standard. Drinking water in communities in southeastern New Mexico commonly exceed the 250ppm sulfate standard, and there are numerous pecan orchards in the area that also utilize water in excess of 250ppm for irrigation. Section 4 mentions compliance with an existing groundwater discharge permit, but does not mention the limits in the permit.
3. Table 1 contains a good summary of the common methods of sulfate removal, with costs in Table 2. The C.E.S.R. process would appear to be misnamed however. Comparing short term vs. long term economic analyses provided useful information as well.
4. Nanofiltration unit utilized 6.7 ppm of an anti-scaling agent. How was this selected? Were there any tests run to optimize this dosage? This typically can be a significant operating cost and should be optimized. Some discussion of both the selection and dosage of the anti-scaling agent would have been helpful.
5. Section 6.2, Design, describes "combined RO/Nanofiltration systems", but I do not see any use of RO, only nanofiltration.

6. I am pleased to see a good evaluation of potential safety concerns with each experimental model. The hot process in particular seems to have a lot of potential safety concerns.
7. Section 6.5 mentions that cotton increases the solubility of sulfate at higher temperatures. Any idea why? A citation of where this phenomenon has been studied would be useful.
8. The full-scale design for the nanofiltration operation as laid out appears to be workable and should be effective.
9. Hot process full-scale design has the significant flaw in that it must be heated, which has the potential to be a very costly aspect of the process. Investigation of waste heat recovery would be useful if deploying this process, or whether utilizing waste heat streams from elsewhere in the copper mill, if available, could be utilized to lower the cost.
10. Good high-level evaluation of alternative methods. Not sure why bacterial sulfur removal was considered unsuitable as that is often a very cheap and low-tech way to go. Was it because of the large amount of land required for a constructed wetland?
11. As a practical consideration, reuse of mine wastewater for potable purposes would be a hard sell to the public. Use of the water in the pecan orchard, or some other agricultural irrigation situation would be a very good option, and could generate income to offset some of the treatment costs, although piping the water 17 miles to the orchard would probably be cost prohibitive. Some more local agricultural need, and not necessarily pecan irrigation, would be a good addition to the analysis of final disposition of the treated water stream.
12. I would agree with the team that the hot process, while looking attractive from a cost point of view, would be the more difficult process to actually operate. In the absence of a free source of waste heat from elsewhere in the mill, the future unknown cost of fuel for heating makes this a questionable solution at best. The hot process also appears to be much more labor intensive, and would require a much more technologically skilled work force to operate than other alternatives.

In summary, you have done an admirable amount of work studying the alternatives, and the solution you propose appears to be well thought out, easily implemented and minimizes cost. Your solution addresses technical, economic, health and environmental issues and is worth pursuing by Freeport McMoran.

Respectfully yours,

Timothy A. Glasco, PE  
Utilities Manager  
Los Alamos County Department of Public Utilities



March 13, 2018

Mr. Benjamin Drewry  
Undergraduate Research Assistant  
University of Arkansas  
Fayetteville, AR

Re: Review of WERC proposal  
Sulfate Removal from Mine-Impacted Waters

Dear Mr. Drewry:

Thank you for the opportunity to review your group's paper. Here are my comments:

- You included all the appropriate treatment technologies that I am aware of, plus one I was not familiar with (the hot process).
- I like the fact that you developed two alternatives, and showed the time frames at which each is most cost-effective.
- I'm a stickler for correctly using hypens. Words such as "low-cost," "cost-effective" and "sulfate-containing" should be hyphenated.
- I assume WPS is your team name—could use a brief explanation, maybe on the cover page.
- "Whilst" sounds British; use "while."
- Use the term "sulfate bioreactors" rather than "biosulfate reactors" (p. 7).
- CESR "potentially achieves lowest concentration," not lowest concentration reduction (Table 1).
- In Table 2, round off costs to nearest dollar or even the nearest \$100,000 (e.g., \$4.5 MM). Too much detail in the numbers creates clutter.
- Place each table completely on one page; otherwise, it is hard to follow.
- I like the fact that you successfully did some filtration trouble-shooting during bench testing.
- I also like that you considered blending back untreated water to improve recovery, which is what would be done at full-scale.
- In Table 4, explain and/or emphasize the recovery and reduction numbers. This is important information!
- Should be "sodium absorption ratio" rather than "rate" (p. 24).
- I would like to see the Section 9 tables made larger, since this is some of the most important information in the paper, even though you may need to cut other material to meet your page limit. Put the Lang Factor between purchased cost and capital cost,

and briefly explain what it is. Also mention what interest rate you used for bringing back future costs, and what inflation rate you used for O&M costs.

- In Section 10, I recommend rewording the first sentence for clarity and accuracy. I believe you have the HP and NF recoveries transposed.
- In Section 12, I would recommend pilot-testing the HP process, then selecting a full-scale process. For a 2000-gpm process in industry, the company would typically pilot-test a chosen technology regardless of how proven or unproven it is.
- I have worked with a start-up company called Solar Multiple that has developed a semi-passive technology for enhancing natural evaporation by a factor of 5-7. This could reduce the area required and costs for brine evaporation. You might consider including this information if it is not too late in the process.
- References are typically listed in alphabetical order.

Please contact me if you have any questions, and let me know how you score in the competition.

Sincerely,

Mark A. Reinsel, Ph.D., P.E.  
President  
Apex Engineering, PLLC