

MOON LITERATURE PROJECT
MLP# 72-1771
LUNAR SCIENCE INSTITUTE LIBRARY
HOUSTON, TX. 77058

REPORT ON THE
LUNAR RANGING
at
MCDONALD OBSERVATORY
FOR THE PERIOD
FEBRUARY 16, 1972 TO MAY 15, 1972

by

E. C. SILVERBERG

and

J. R. WIANT

UNIVERSITY OF TEXAS

Research Memorandum in Astronomy #72-007

May 1972

*This work is supported by NASA Grant NGR 44-012-165

QB
591
R425
1972b

LIBRARY
LUNAR SCIENCE INSTITUTE
HOUSTON, TEXAS 77058

ABSTRACT

The laser ranging operation at McDonald Observatory successfully measured more than 150 lunar ranges during the three lunations ending on May 13, 1972. The accuracy of the measurements averaged about ± 15 cm.

TABLE OF CONTENTS

Section	Page
I. Data Acquisition Activities	
A. The Observing Log.....	1
B. Data Reduction Notes.....	3
Accuracy.....	3
The Clock.....	4
The Laser Pulse Width.....	5
II. Engineering R & D: The Detector.....	6
III. The Laser Guiding.....	8
Appendix I	
Appendix II	

I. DATA ACQUISITION ACTIVITIES

A) The Observing Log

The three lunations between February 16, 1972 and May 15, 1972 resulted in the measurement of more lunar ranges than during any other similar span in the history of the lunar ranging project. Good weather and seeing conditions coupled to the lack of any major equipment breakdowns resulted in 192 attempted ranging efforts during the quarter. About 158 of those attempts were successful for approximately an 80% success rate. Of these successful range measurements, many were the result of automatic computer driven runs at unilluminated laser ranging sites, a method which has caused us some difficulty in the past. As usual, a complete history of the quarter's activities can be covered with the aid of the operations log which makes up Appendix I.

The most significant technical improvements during the quarter were in regards to the successful installation of a new photomultiplier tube (RCA 31034A). The initial installation of this photomultiplier resulted in over a factor of 2 increase in signal, but unfortunately, did not allow us to use our usual calibration method. During the following few weeks some loss of accuracy was tolerated in order to use the extra efficiency to maintain a high acquisition rate. By the end of the quarter, the difficulties related to the calibration of this system were overcome and the new high efficiency photomultiplier was being used daily with good success. These improvements will be covered in more detail in Section II. The rest of this report will cover the usual information related

to data reduction. In addition, we will add a section on the current guiding techniques since that area of the laser ranging project has not been documented in some time.

B) Data Reduction Notes

The Accuracy - Due to the number of changes in the pulse counting system associated with integrating the gallium arsenide photomultiplier, it was not possible to consistently hold the overall accuracy to subnanosecond levels during the last quarter. When the feedback calibration system is in operation, one can normally recover the systematic electronic calibration correction to about ± 300 to ± 400 picoseconds. This result refers, as near as possible, to a simple arithmetic mean of the feedback calibration returns. In the absence of feedback circuitry we are forced to tie the calibration system to the nearest available value by using the photodiode light pulser as a secondary standard. The additional uncertainty induced by calibration in this manner is about ± 500 picoseconds. Thus, our calibration accuracy when using the light pulser is approximately ± 800 to ± 900 picoseconds. Since the single shot pulse width will introduce an additional error, we cannot achieve ± 15 centimeter accuracy unless the feedback calibration system is operating.

The following is a list of the approximate uncertainties which should be assigned to the electronic calibration constant throughout the last quarter. They are based on the type of calibration used, the consistency of nearby calibration points, and the apparent quality of the raw calibration data. A complete list of the calibration data is included as Appendix II.

February 16 - February 22 ± 800 picoseconds

February 23 - February 24	\pm 500 picoseconds
February 25 - March 4	\pm 500 picoseconds
March 5 - March 7	\pm 300 picoseconds
March 8 - March 23	\pm 800 picoseconds
March 24 - March 26	\pm 400 picoseconds
March 27 - March 30	\pm 800 picoseconds
April 1	\pm 300 picoseconds
April 5 - April 10	\pm 800 picoseconds
April 17 - April 26	\pm 1.5 nanoseconds
April 27 - April 28	\pm 500 picoseconds
April 29	\pm 4 nanoseconds
April 30 - May 15	\pm 400 picoseconds

The Clock - The frequency of the laser crystal oscillator was not purposely altered during the entire quarter. Ninety-five percent of the day to day Loran C readings fit the best parabola with an RMS deviation of approximately 6 microseconds. Most of this deviation seems to be due to the receiver skipping between various waves in the Loran C pulse. The wave skipping is not severe enough to disturb the long term tracking capabilities of the receiver. The six microsecond deviation could, however, be interpreted as an instability in the crystal oscillator. Even if the latter is true it would be unimportant unless this fluctuation is symptomatic of even more severe minute-minute or hour-hour frequency shifts. Our resources for determining such a possibility are clearly inadequate at present and must be improved. We can,

however, rule out frequency fluctuations much larger than 5 parts in 10^{10} over successive 10 minute time spans or fluctuations greater than 1 part in 10^{10} over several hours.

Laser Pulse Width - The laser pulse width has remained at about 3 nanoseconds FWHM for the entire quarter. No evidence was seen of the very short pulse structure which has plagued us in the past. In spite of the consistency of the laser pulse width, the single shot uncertainty did vary due to the additional width which was introduced by some of the photomultiplier testing. Furthermore, in one case an error in connecting the discriminator start cable produced additional jitter in the shot to shot performance.

All data taken during the last quarter should be assumed to have a single shot uncertainty of approximately ± 2 nanoseconds with the following exceptions (all dates are inclusive):

February 18 - February 20	± 3 nanoseconds
March 8 - March 23	± 3 nanoseconds
April 29	± 5 nanoseconds

II. ENGINEERING R & D: THE DETECTOR

The only engineering change which affected the laser system during the last quarter was installation of a new photomultiplier tube. We received two RCA 31034's during mid-February. Both tubes have approximately 15% quantum efficiency at 6943\AA , which is far superior to our previous photomultiplier. Due to some installation difficulties, however, we did not put the photomultipliers in their final configuration until nearly the first of May. The problems which had to be overcome were: a) lowering of the RF noise from the laser pockel cell to allow using the feedback calibration system; b) the rewiring of the photomultiplier base into a more suitable arrangement for the gallium arsenide photomultiplier; and c) testing with various amplifier discriminator combinations to reach the optimum configuration for this tube's parameters.

The final configuration which we are now using is shown in Figure 1 on the next page. The photomultiplier is operated at 2200 volts, 200 volts over the manufacturers recommended rating. At this level the photomultiplier produces a 20 millivolt pulse into 125 ohm load resistance. The pulse to pulse jitter has not been definitively measured, but it is certainly not significant compared to the width of our laser pulse. The dark current of the photomultiplier averages about 14 kilohertz at 60° Fahrenheit. With this detector package configuration, the overall counting efficiency of the laser ranging receiver optics and electronics approaches 1%.

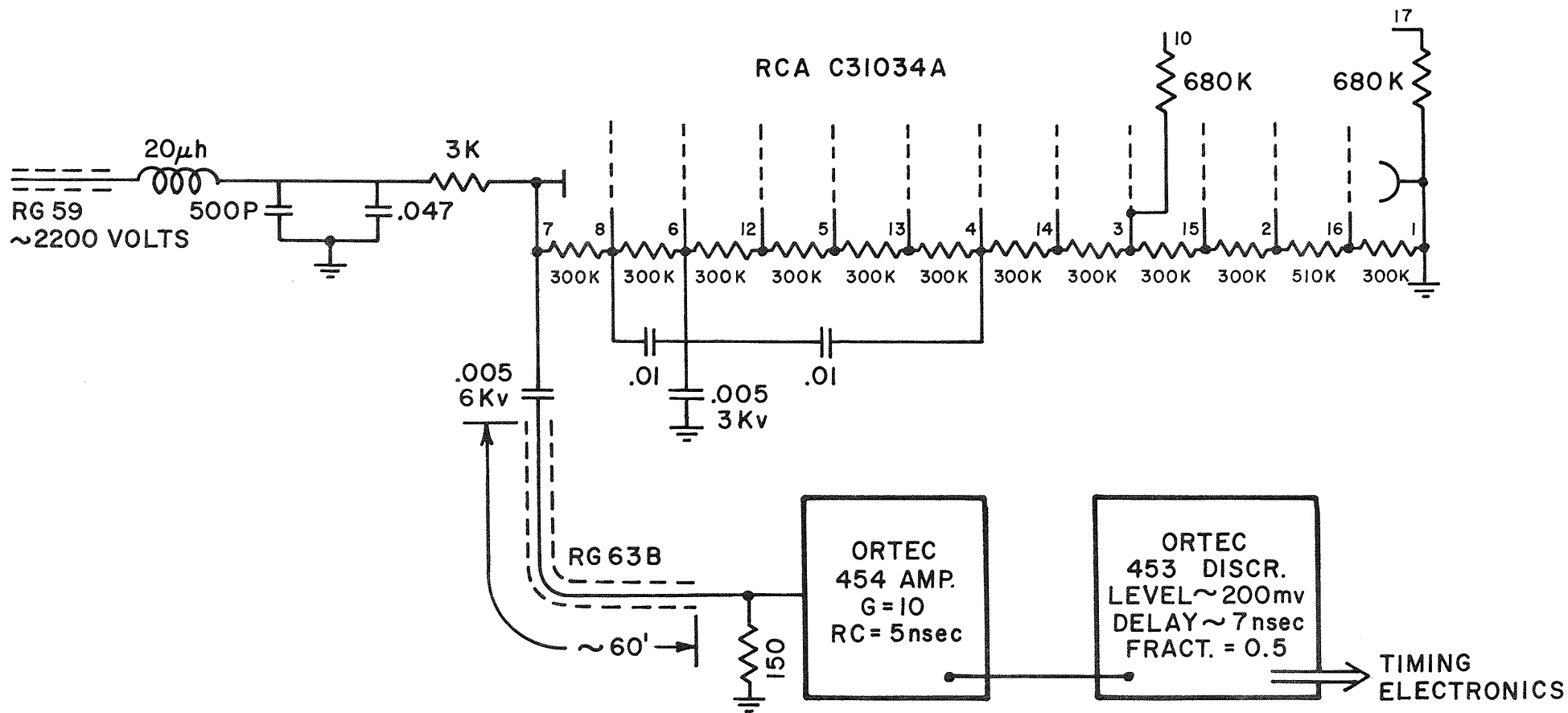

FIGURE 1: PHOTOMULTIPLIER ASSOCIATED ELECTRONICS, APRIL 17, 1972

III. LASER GUIDING

The guiding techniques for the lunar laser ranging project have evolved a number of times since the project began. This section will cover the present techniques which have not yet been recorded in print. The methods used vary primarily as to whether or not the LRR site is either illuminated or unilluminated on the lunar surface. Slight modifications occur, however, between various observers, seeing conditions and the degree of telescope defocusing. The following is a synopsis of the various methods.

Equipment - The following page, Figure 2, shows the main optics associated with the laser ranging experiment. The guiding optics are located behind the dichroic mirror allowing the observer to guide simultaneously with the outgoing laser beam. These optics have a field diameter of approximately 21 arc minutes, a resolution throughout the field of approximately 1/2 arc seconds, and a field which is flat to approximately 2 arc seconds. Mounted at the focus of these reducing optics is a x-y stage which rotates at the average lunar rate so as to follow the coude rotation of the lunar image. The x-y stage has a 2 x 2 inch travel and is positionable to an accuracy of better than .01 millimeters (corresponding to \pm .2 arc seconds).

The preliminary alignment, exclusive of internal laser adjustments and telescope alignment, consists of the following steps.

A) First, the helium-neon laser beam is adjusted to be both parallel to and coaxial with the outgoing ruby beam. This procedure primarily involves observing both beams with the alignment telescope as shown near the detector package. B) The diverging lens

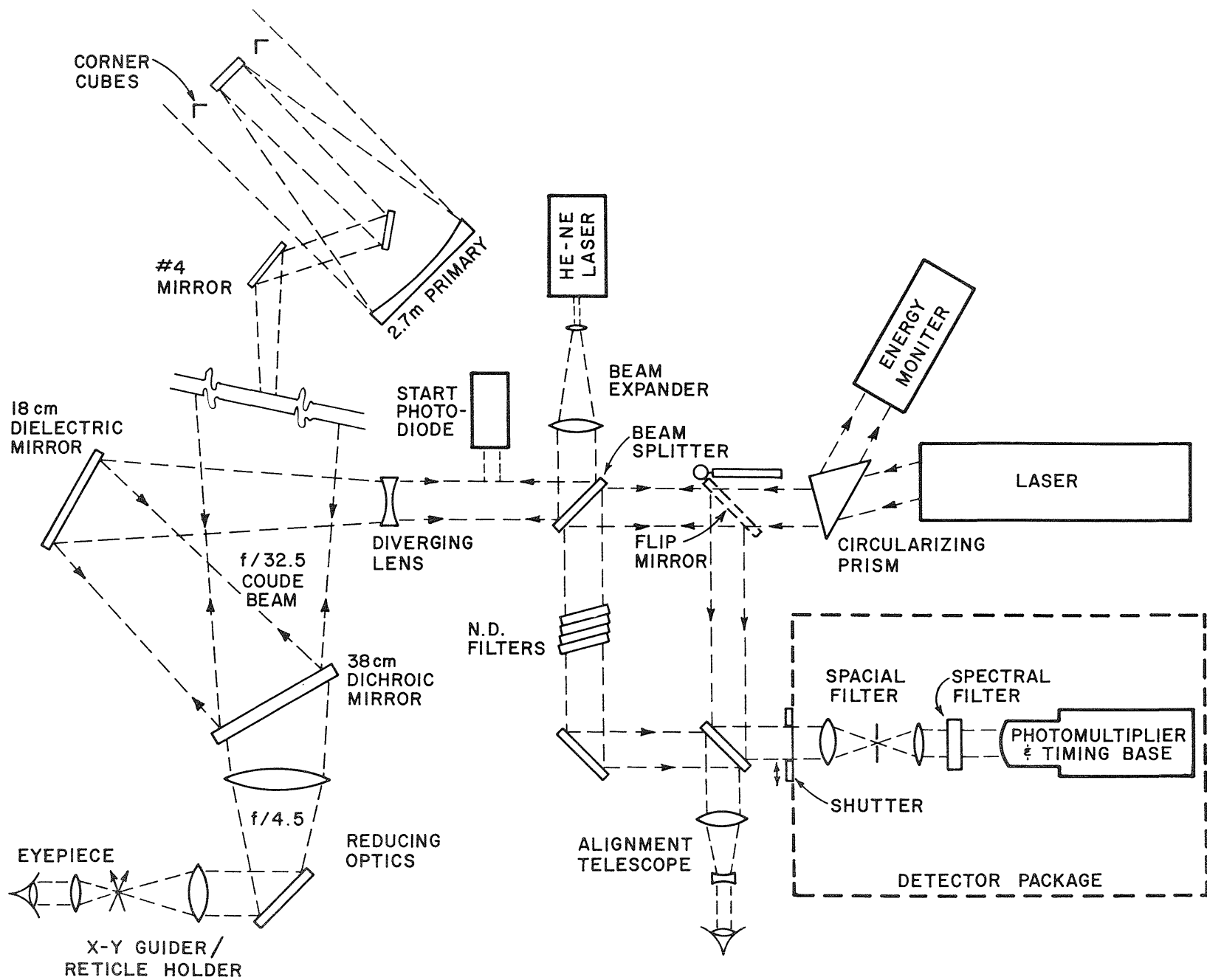

FIGURE 2: THE OPTICS ASSOCIATED WITH THE LUNAR LASER RANGING EXPERIMENT

is removed and the .8 inch diameter helium-neon beam is traced through all of the main optics to center the laser beam and prevent vignetting. The dichroic #5 mirror is adjusted so that the retroreturn from the center of the telescope's secondary mirror is centered in the field as viewed through the guiding optics. C) The diverging lens is placed in its proper position and located so that the expanded helium-neon beam is centered on the #6 dichroic mirror. D) A retroreflector is placed in the helium-neon beam ahead of the diverging lens and the retroreturn is used to align the spacial and spectral filters located in the detector package. E) The feedback path through which the laser and helium-neon were originally aligned is then adjusted so that the light from the feedback path passes through the spacial filter. F) The 45° mirror located within the guiding reducing optics is aligned so that the helium-neon retroreturn from the corner reflectors on the secondary supports falls at the center of rotation of the x-y stage.

These adjustments take about one hour when performed by two practiced men. Normally one alignment will suffice for the entire lunation unless major repairs are done to the laser oscillator cavity.

In addition to the optical equipment we have just described, two additional electronic aids are essential to the operation of the laser ranging experiment. The first is very accurate digital controlled telescope track rates in both RA and declination axes. This allows us to set the track rates of the 107" telescope with a precision of .1%. In addition, an IBM 1800 computer which is

located in the 107" telescope dome calculates the necessary track rates to permit the telescope to guide any feature on the lunar surface. The precise calculation of and implementation of these very accurate track rates permits long periods of open loop guiding which would not be possible otherwise. Furthermore, the IBM 1800 computer is connected to the drive functions of the 107" telescope such that it can move the telescope under computer control with a resolution of 1/20 of an arc second in either coordinate. The necessity of these functions will become clearer in the following sections.

Illuminated Guiding - When the LRRR site is illuminated, the basic system is to either offset guide from a nearby crater or to dead-reckon the telescope to the correct position. Prior to the run the guider will focus the telescope through the diverging lens on a nearby star. Under normal circumstances the guider will focus the telescope as well as possible such that the outgoing laser beam is seeing limited. Upon reaching the moon, the first object will normally be the Apollo 15 corner. The site is always dead-reckoned because the Hadley Rill feature makes any reticle or offset guiding unnecessary. Very little practice is required for the guider to learn to align the ruby retroreflections from the telescope corner reflectors at the correct point on the lunar surface. Since the accurate guide rates have been placed in the telescope control systems, small corrections are all that is necessary in order to follow the site. The guider is aided in holding on the

correct lunar site by an audible bell which rings whenever the previous shot has resulted in a signal correlated with the lunar ephemeris.

Following the acquisition of the Apollo 15 corner reflector, the guider will then move on to the next most favorably placed corner reflector. If the seeing is about 1 arc second, he may also dead-reckon the Apollo 11 and 14 sites. The former is marked by a small feature which we call the "Cat's Paw", which is located approximately one arc second ENE from the apparent pointing position. Unfortunately, the feature is of low contrast and can only be used near terminator crossing and when the seeing is quite good. The Apollo 14 corner reflector, on the other hand, can be dead-reckoned at moderate phase angles using a high albedo spot which is located about one arc second WSW of the apparent position. The dead-reckoning method is, of course, the fastest way to point the telescope and the ease with which the Apollo 15 site can be dead-reckoned makes it much more usable than just simply the factor of three improvement in the size of the corner reflectors. It has been our experience that the other two sites can only be dead-reckoned after many long hours of practice at the telescope guiding position.

If the cat's paw or the white spot is not visible, the illuminated guiding will consist of offsetting from nearby craters. First, the x-y stage is rotated such that the x axis is aligned with the right ascension coordinate of the telescope. Accurate

offsets in right ascension and declination are then calculated by the IBM 1800 computer and converted to x-y offsets on the rotatable stage. The guider then aligns the guide crater on the helium-neon retroreflection and uses the offsets to move the telescope to the appropriate position. Normally one carefully done offset is sufficient to locate the LRRR. The most commonly used offset guide craters are: Moltke, for the Apollo 11 site; and Fra Mauro D, for the Apollo 14 site.

Dark Field Guiding - If the site in question is not illuminated then a type of open loop tracking is performed. In these circumstances, the guider will set the laser beam divergence to approximately 3 arc seconds. The method then consists of aligning the telescope very carefully on a visible crater in the illuminated portion of the moon, setting the computer calculator track rates into the telescope control system, and then asking the computer to perform the required offsets in right ascension and declination such that the telescope will start pointing at the LRRR site. This control is facilitated by a number of convenient computer compatible commands which may be put in through a teletype in the laser room. The offset is done by the 1800 computer without calculating for any differential telescope flexure, since flexure is small over a lunar diameter. The computed offset does take into account all other known corrections including differential refraction.

The IBM 1800 computer drives the telescope in both right ascension and declination at a rate of 25 arc seconds per second

until the corner reflector site is reached. The telescope is then allowed to guide in an open loop fashion for approximately 30 laser shots. If a successful acquisition has not been made, the guider will return to the offset crater and redrive the telescope for as much as 200-300 laser shots. During 3 arc second seeing we achieve about a 60% success rate in acquiring the Apollo 15 corner reflector while offsetting from the crater Lansburg A. The apparent accuracy of the computer telescope drives can be estimated by noting that the acquisition rate is considerably lower when the beam divergence is only 2 arc seconds; although, it is difficult to quantify the degree of improvement.

Over the last few months the McDonald staff has had a number of requests to supply pictures and crater coordinates of the sites which we use for guiding. We have not as yet obtained any pictures which are superior to those which can be found in the publications of the Lunar and Planetary Lab. We have, however, included the following list of our most commonly used sites and crater coordinates. We strongly caution any potential users against blindly using these coordinates for their crater offsets. We are well aware that some of the sites given in the following lists differ somewhat from those which might commonly be derived from published maps. Many of them have been tuned by trial and error to their present values. Either due to systematic telescope drive errors, subjective pointing offsets, scale problems, or whatever, these are the coordinates which work consistently on the 107" telescope.

They may have very little bearing on the pointing problems which could be encountered at another telescope with a different crew doing the guiding.

COMMONLY USED LUNAR COORDINATES

Dionysius A	.3033	.0294
Moltke	.4096	-.0100
Taruntiuse E	.6427	.0966
Webb	.8654	-.0162
Lade A	.1681	.0473
Bruce	.0070	.0204
Gambert B	-.2005	.0370
Lansburg A	-.5164	.0032
Encke C	-.5933	.0115
Hermann	-.8416	-.0152
Fra Mauro D	-.3012	-.0830
Turner F	-.2440	-.0288
Apollo 11	.3975	.0112
Apollo 14	-.3000	-.0630
Apollo 15	.0580	.4420

APPENDIX I

McDonald Lunar Ranging Operating Log

from

February 16, 1972 to May 15, 1972

STATION LOG, FEB. - MAR. 1972

DATE	TIME	RUN NO.	NO. OF SHOTS	RETURNS	WEATHER	SEEING(π)	COMMENTS
Feb. 18	1910-2000	(65)	350/0	4/0	cirrus	3	computer guiding
Feb. 19	1400-	---	---	---	cloudy	-	C31034 2000 volts blew flashlamp
	1730-1800	(66)	90/0	2/0?	cirrus	3	
	2030-	---	---	---	cloudy	-	
Feb. 20	1530	(67)	160/0	3/0	clear	3	poor contrast
		(68)	120/0	10/0	clear	2	
		(69)	120/3	1/3	"	2	defocused slightly
	2100	(70)	50/0	10/0	"	2	"
		(71)	50/0	10/0	clear	2	defocused slightly
		(72)	90/3	9/3	"	2	"
Feb. 21	1600-1900	---	---	---	clouds	10	bad seeing, clouds
	2100	(73)	150/3	8/3	light cirrus	2	defocused slightly
		(74)	75/0	10/0	"	"	"
		(75)	50/3	7/3	"	"	"
Feb. 22	1650-1720	(76)	220/3	16/3	light cirrus	3	defocused slightly
		(77)	50/3	11/3	light cirrus	3	defocused slightly
		(78)	200/0	10/0	"	"	"
		(79)	70/2	2.5/2	"	"	"
	2245-2315	(80)	120/3	10/3	"	"	"
		(81)	70/3	10/3	light cirrus	3	defocused slightly
		(82)	110/0	10/0	"	"	"
Feb. 23	1815-1830	(83)	150/3	9/3	clear	2	used polarizer
		(84)	100/3	28/3	clear	2	
		(85)	50/2	9/2	"	"	
		(86)	50/0	10/0	"	"	
		(87)	50/3	15/3	"	"	
	0000	(88)	50/3	24/3	clear	2	
Feb. 24	1845-1915	(89)	150/3	17/3	clear	2	
		(90)	115/3	10/3	clear	2	
		(91)	175/0	10/0	"	"	
		(92)	230/2	10/2	"	"	
		(93)	75/3	10/3	"	"	
	0045-0115	(94)	255/3	10/3	clear	2	
Feb. 25	2300-0000	(95)	200/3	8/3	light cirrus	2	
		(96)	150/0	8/0	"	"	

DATE	TIME	RUN. NO.	NO. OF SHOTS	RETURNS	WEATHER	SEEING (π)	COMMENTS
Feb. 25	2300-0000	(97)	100/2	11/2	light cirrus	2	
		(98)	250/3	7/3	"	"	
	0200-0215	(99)	100/3	9/3	light cirrus	2	
Feb. 26	2045-2115	(100)	150/3	9/3	light cirrus	2	
	2345-0045	---	---	---	clouds	-	
	0245-0315	---	---	---	"	-	
Feb. 27	2150-2215	(101)	100/3	10/3	clear	3	
	0015-0115	(102)	200/3	6/3	clear	3	
		(103)	180/0	0/0	"	"	laser probably deteriorating
		(104)	50/3	7/3	"	"	lost calcite prism completely
	0315-0345	(105)	200/3	0/3	clear	3	
Feb. 28	2230-2245	(106)	150/3	11/3	clear	3	
	0130-0230	(107)	450/3	9/3	"	4+	
		(108)	200/0	3/0†	"	"	
	0430-0450	(109)	200/3	6/3	clear	4+	windy telescope moving
Feb. 29	2315-2330	---	---	---	clouds		
	0130-0200	---	---	---	"		
	0300-0400	(110)	400/3	0/3	hazy	5	windy
Mar. 1	0000-0500	---	---	---	dusty	-	bad seeing
Mar. 2	0005-0034	(111)	250/3	13/3	clear	4	
	0300-0400	(112)	150/3	11/3	clear	3	tape and laser trouble
	0600-0645	(113)	250/3	9/3	clear	4	
Mar. 4	0045-	---	---	---	dusty	9	
	0345-	"	"	"	"	"	
	0645-	"	"	"	"	"	
Mar. 5	0200-0220	(114)	110/3	9/3	clear	3	
	0440-0545	(115)	125/3	9/3	clear	3	seeing went from 3 to 4 during run
		(116)	250/0	0/0	"	4	
		(117)	150/3	8/3	"	"	
	0715-0745	(118)	250/3	6/3	clear	4	

DATE	TIME	RUN NO.	NO. OF SHOTS	RETURNS	WEATHER	SEEING(π)	COMMENTS
Mar. 6	04:05-05:05	(119)	200/3	14/3	clear	2	
		(120)	150/2	6/2	"	"	
		(121)	160/0	0/0	"	"	
	07:00-08:30	(122)	586/3	15/5	clear	3	2 separate ranges
Mar. 7	05:00-06:30	(123)	100/3	10/3	cirrus	4	
	07:00-07:45	(124)	150/3	9/3	clear	"	
		(125)	250/2	5/2	"	"	
		(126)	150/3	8/3	"	"	
Mar. 8	05:00-06:00	(127)	200/3	0/3	clear	9	C31034 G=40
	07:00-07:30					9	d=3.0
Mar. 9	06:00-07:00	(128)	240/3	0/3	clear	2	C31034
		(129)	100/2	7/2	"	"	
	08:00-12:00						computer trouble
Mar. 10	06:40-08:00	(130)	300/3	3/3?	clear	3	
Mar. 11	07:00-08:00	(131)	300/3	0/3	clear	3	
Mar. 12-20	New Moon Break						

Totals for Feb. - March lunation

Tries
16/0
0/1
7/2
44/3

Successful Range Measurements
12/0
0/1
7/2
38/3

STATION LOG, Mar. - April 1972

DATE	TIME	RUN NO.	NO. OF SHOTS	RETURNS	WEATHER	SEEING (")	COMMENTS
Mar. 20	15:00-15:45	(132)	120/0	0/0	clear	4	poor contrast
	18:00-19:00	(133)	50/0	10/0	"	3	dust
		(134)	120/3	8/3	"	"	C31034, 2100V G=200
		(135)	125/0	9/0	"	"	
	20:00-20:45	(136)	100/0	9/0	"	1/2	
		(137)	75/3	0/3	"	"	
Mar. 21	15:00	---	---	---	cloudy	-	
	19:15-19:50	(138)	100/0	0/0	heavy cirrus	1	
Mar. 22	17:00	---	---	---	cloudy	-	31000F, 3000V G=100
	20:00	---	---	---	"	-	
	22:30	(139)	60/3	11/3	clear	2	
		(140)	230/0	0/0	cloudy	2	
		(141)	100/3	3/3	"	"	
Mar. 23	19:00-20:00	(142)	100/3	9/3	cirrus	3	31000F, 3150V base mod.
		(143)	200/0	0/0	"	"	
		(144)	150/2	0/2	"	"	blew flashlamp
	23:00-00:00	(145)	250/3	9/3	light cirrus	3+	
		(146)	200/2	0/2	more cirrus	"	
		(147)	100/3	3/3	thick cirrus	"	
Mar. 24	19:00	---	---	---	---	-	cancelled for PMT base repair 31000F, 3000V disc. = 1.0 got feedback calib. telescope realignment
	22:00	---	---	---	---	-	
	01:00	(148)	250/3	0/3	clear	3	
Mar. 25	19:45	---	---	---	---	-	cancelled for PMT work 31000F, 3000V d=0.80
	22:20-23:00	(149)	300/3	7/3	clear	4	
	01:30-02:20	(150)	250/3	0/3	"	6	
Mar. 26	20:00-20:26	(151)	150/3	11/3	clear	2	31000F, 3000V D=1.0
		(152)	50/3	11/3	"	"	
	23:00-00:05	(153)	300/2	0/2	"	"	
		(154)	200/3	6/3	"	"	
		(155)	250/3	0/3	clear	3	windy image motion

DATE	TIME	RUN NO.	NO. OF SHOTS	RETURNS	WEATHER	SEEING(π)	COMMENTS
Mar. 27	23:10-23:40 02:20-03:20	(156)	150/3	9/3	clear	2	31034, 1850V
		(157)	150/3	7/3	"	3	windy image motion
		(158)	250/0	6/0	"	"	"
		(159)	200/2	4/2	"	"	"
		(160)	150/3	9/3	"	"	"
Mar. 28	00:30-01:15	(161)	250/3	10/3	dusty	5	poor seeing
		(162)	250/0	3/0	"	"	"
		(163)	235/3	0/3	"	"	"
Mar. 30	04:15	---	---	---	dusty	10	no run
	00:00	---	---	---	dusty	8	sudden drop in temperature
	03:00	---	---	---	"	"	"
Mar. 31	00:00	(164)	100/3	9/3	clear	4	
		(165)	100/2	7/2	"	3	
		(166)	200/0	0/0	"	"	
		(167)	50/3	12/3	"	"	
		(168)	100/3	12/3	"	2	
Apr. 1	01:00-01:30 05:00-05:45	(169)	50/3	8/3	clear	2	
		(170)	150/3	13/3	"	"	
		(171)	300/2	0/2	"	3	blew 3rd amp flashlamp
Apr. 2	02:00-02:45 05:00-06:15	(172)	230/3	5/3	light to heavy	5	
		(173)	110/3	7/3	cirrus		
		(174)	290/0	7/0	"	3	
		(175)	200/3	2/3	"	"	
Apr. 3	03:00-03:25 06:00-07:15	(176)	100/3	9/3	clear	3	
		(177)	150/3	7/3	"	"	
		(178)	250/0	8/0	"	"	
		(179)	200/3	2/3	"	4	very large π
Apr. 4	04:45	---	---	---	dust storm	-	no run 31000F, 2950V
Apr. 5	05:00	---	---	---	cirrus and dust	-	D=1.35
	07:00-07:45	(180) (181)	250/3 330/3	14/3 3/3	light cirrus "	4 "	
Apr. 6	05:45-07:00	(182)	180/2	8/2	light cirrus	3	
		(183)	300/3	8/3	"	"	
		(184)	150/2	4/2	heavy cirrus	"	

DATE	TIME	RUN NO.	NO. OF SHOTS	RETURNS	WEATHER	SEEING (π)	COMMENTS
Apr. 7	05:30-07:15	(185)	400/2	4/2	light cirrus	4	
		(186)	330/3	3/3	"	"	
		(187)	200/2	5/2	"	"	poor contrast
	09:30-10:00	(188)	100/3	0/3	"	"	"
Apr. 8	05:45-07:00	(189)	90/3	11/3	clear	2	C31034A, 1850V
		(190)	60/2	7/2	"	"	
		(191)	90/0	6/0	"	"	
		(192)	210/3	6/3	"	"	
	09:15-09:50	(193)	110/3	6/3	"	"	
Apr. 9	07:00-08:30	(194)	210/3	6/3	cirrus	2	
		(195)	120/3	12/3	"	"	
	10:00-10:20	(196)	90/3	8/3	clear	3	poor contrast

Apr. 10 - 17 New Moon Break

Totals for Mar. - April lunation

Tries
13/0
0/1
11/2
41/3

Successful Range Measurements
8/0
0/1
7/2
32/3

STATION LOG, APR. - MAY 1972

DATE	TIME	RUN NO.	NO. OF SHOTS	RETURNS	WEATHER	SEEING(π)	COMMENTS
Apr. 17	16:30 19:40-20:20	(197)	230/0	3/0	cloudy clear	3	
Apr. 18	14:30 17:30 20:30				cloudy		all runs cancelled
Apr. 19	15:40				cloudy		"
Apr. 20	19:30-20:20 22:30-23:30	(198) (199) (200)	150/3 150/0 150/3	9/3 6/0 2/3	dust, wind " " dust, wind	4 " "	run cancelled
Apr. 21	17:50-18:15 20:50-21:45 23:30-23:45	(201) (202) (203) (204) (205)	150/3 150/3 100/3 200/0 47/3	16/3 2/3 22/3 9/0 8/3	clear " " " clear	2 " " " 2	computer trouble
Apr. 22	18:00-18:30 21:00-21:50 00:00-00:25	(206) (207) (208) (209) (210) (211)	100/3 100/3 50/2 135/0 50/3 100/3	15/3 13/3 12/2 7/0 14/3 10/3	clear " " " " "	2 " " " " "	
Apr. 23	18:45-19:15 21:00-22:00 00:30-01:00	(212) (213) (214) (215) (216) (217)	100/3 110/3 200/2 100/0 50/3 200/3	12/3 10/3 6/2 5/0 7/3 10/3	clear clear " " " clear	1 2-4 " " " 2-4	
Apr. 24	19:30-20:00 22:45-23:50 01:30-02:00	(218) (219) (220) (221) (222) (223)	70/3 200/3 200/2 250/0 200/3 400/3	11/3 9/3 7/2 3/0 5/3 4/3	clear " " " " "	2 4 " " " 5	

DATE	TIME	RUN NO.	NO. OF SHOTS	RETURNS	WEATHER	SEEING (π)	COMMENTS
Apr. 25	20:06-20:45						Computer problems run cancelled changed base
	23:00-23:30	(224)	250/3	7/3	clear	4	
	02:00-02:30	(225)	200/3	8/3	"	"	
Apr. 26	20:50-21:00	(226)	50/3	14/3	clear	2	
	23:45-01:00	(227)	150/3	7/3	hazy	"	
		(228)	350/2	1/2	"	"	
		(229)	150/3	8/3	"	"	
	02:45-						windy, bad seeing run cancelled
Apr. 27	21:45-22:15	(230)	150/3	5/3	hazy	2	changed cable delay
	00:45-						6-8 seeing run cancelled
	03:30-						"
Apr. 29	22:15-22:40	(231)	150/3	11/3	clear	3	
	01:20-02:50	(232)	100/3	8/3	"	"	changed calcite
		(233)	400/2	7/2	"	"	prism
		(234)	150/0	7/0	"	"	
		(235)	150/3	5/3	"	"	
	04:20-04:45	(236)	150/3	4/3	"	"	
Apr. 30	00:00-01:20	(237)	180/3	9/3	cirrus	3	
		(238)	150/2	5/2	"	"	
		(239)	200/0	5/0	"	"	
		(240)	100/3	6/3	"	"	
	04:00-04:45	(241)	315/3	7/3	heavy cirrus	3	
May 1	01:45-				cloudy		run cancelled
May 2	02:50-03:20	(242)	200/3	11/3	cirrus	2	
	06:15-07:00	(243)	250/3	4/3	"	"	
May 3	03:50-05:00	(244)	150/3	15/3	clear	3	
		(245)	150/0	11/0	"	"	
		(246)	150/2	9/2	"	"	
		(247)	50/3	9/3	"	"	
	07:30-07:45	(248)	100/3	11/3	"	"	
May 4	04:20-05:00	(249)	50/3	9/3	clear	4	
		(250)	250/2	3/2	"	"	
		(251)	150/3	9/3	"	"	
	08:15-				cloudy		run cancelled

DATE	TIME	RUN NO.	NO. OF SHOTS	RETURNS	WEATHER	SEEING(π)	COMMENTS
May 5	04:00- 08:00-08:40	(252)	200/2	0/2	cloudy cirrus	2-3	run cancelled
May 6	04:00- 07:00- 09:00-09:20	(253) (254)	60/2 180/3	7/2 4/3	cloudy " light cirrus "	3 "	run cancelled "
May 7	05:30 08:30-11:30				cloudy		run cancelled no runs dome painting
May 8	06:45-07:30	(255)	120/3	11/3	clear	3	
May 9	07:45-08:15 10:00-	(256) (257)	240/2 250/3	4/2? 12/3	" cirrus	" 3	long computer drive sand blasting dome

May 10 - 17 New Moon Break

Totals for April - May lunation

Tries
9/0
0/1
11/2
41/3

Successful Range Measurements
8/0
0/1
8/2
40/3

Totals for the Quarter

Tries
38/0
0/1
29/2
126/3

Successful Range Measurements
27/0
0/1
22/2
109/3

APPENDIX II

Calibration Data
from

February 15, 1972 to May 15, 1972

CALIBRATION DATA FROM FEBRUARY 15, 1972 TO MAY 15, 1972

The following pages contain the results of the various calibration checks which have been made on the laser ranging system during the last quarter. There are three main data types which comprise this calibration. We have listed all the data from those three data types in the form of calibration numbers as well as the final calibration constant which represents the published value. We feel that listing these calibration values will give the reader a better feeling for the consistency of the calibration data as well as the difficulties involved in deriving a correct value during the miscellaneous system changes.

A) The Pulser Feedback

The pulser feedback value shown in Row A is the arithmetic mean of a large number of simulated lunar returns which were derived from a photodiode light pulser. The light pulsing device electrically starts the laser ranging electronics and stops it at the single photoelectron level with a 3 nanosecond light pulse. This number can be derived whether or not the feedback calibration system is operating. Thus, it is used primarily to calibrate those systems which were not calibratable in the usual fashion. All of the units shown are in nanoseconds. Asterisks or question marks indicate particularly good or suspect data respectively.

B) The Laser Feedback (Picture)

The second row of numbers contains the arithmetic mean of the short range feedback returns which were measured by the auxillary calibration system. The auxillary system consists of a time-to-pulse height converter and a pulse height analyzer measuring the difference in delays between the start and stop sides of the lunar laser ranging electronics during lunar ranging.

C) The Laser Feedback (Graph)

The third row, C, shows the arithmetic mean of the feedback range as recorded on paper tape during laser firing by the main timing system. An example of the processed data is included. The data was processed in the manner documented in the previous quarterly report. The average refers to all feedback returns within

4 nanoseconds of the mode of the feedback distribution. This number is the basic and most powerful of calibration constants since it includes the entire timing system in its derivation. It differs from the final published value only by the 2.9 nanosecond geometric correction. It differs from Row B only in the amount added by the system verniers.

D) The Corrected Calibration Value

The last row contains the corrected electronic calibration correction for the entire laser ranging system. Some arrows have been drawn to indicate the primary point from which this number was derived. The decimal has been suppressed since this is the way in which the constant appears on the transmitted data cards. In some cases a single letter has been added following this number to indicate the relative quality of the calibration constant. This quality figure is based on the number of feedback returns used to find the arithmetic mean, the consistency of nearby calibration points, or the degree to which the secondary pulser standard must be used to infer the final answer. The quality figures are keyed to the following table.

- A - better than ± 200 picoseconds
- B - ± 200-400 picoseconds
- C - ± 400-600 picoseconds
- D - ± 600-1000 picoseconds
- E - ± 1.0-1.5 nanoseconds

F - \pm 1.5-2.0 nanoseconds

G - \pm 2.0-4.0 nanoseconds

H - worse than \pm 4.0 nanoseconds

BINWIDTH 0.2 NSEC (0.05 IN.)

THE AVERAGE = 27.8 NSEC

THE UNCERTAINTY IS 0.22 NSEC

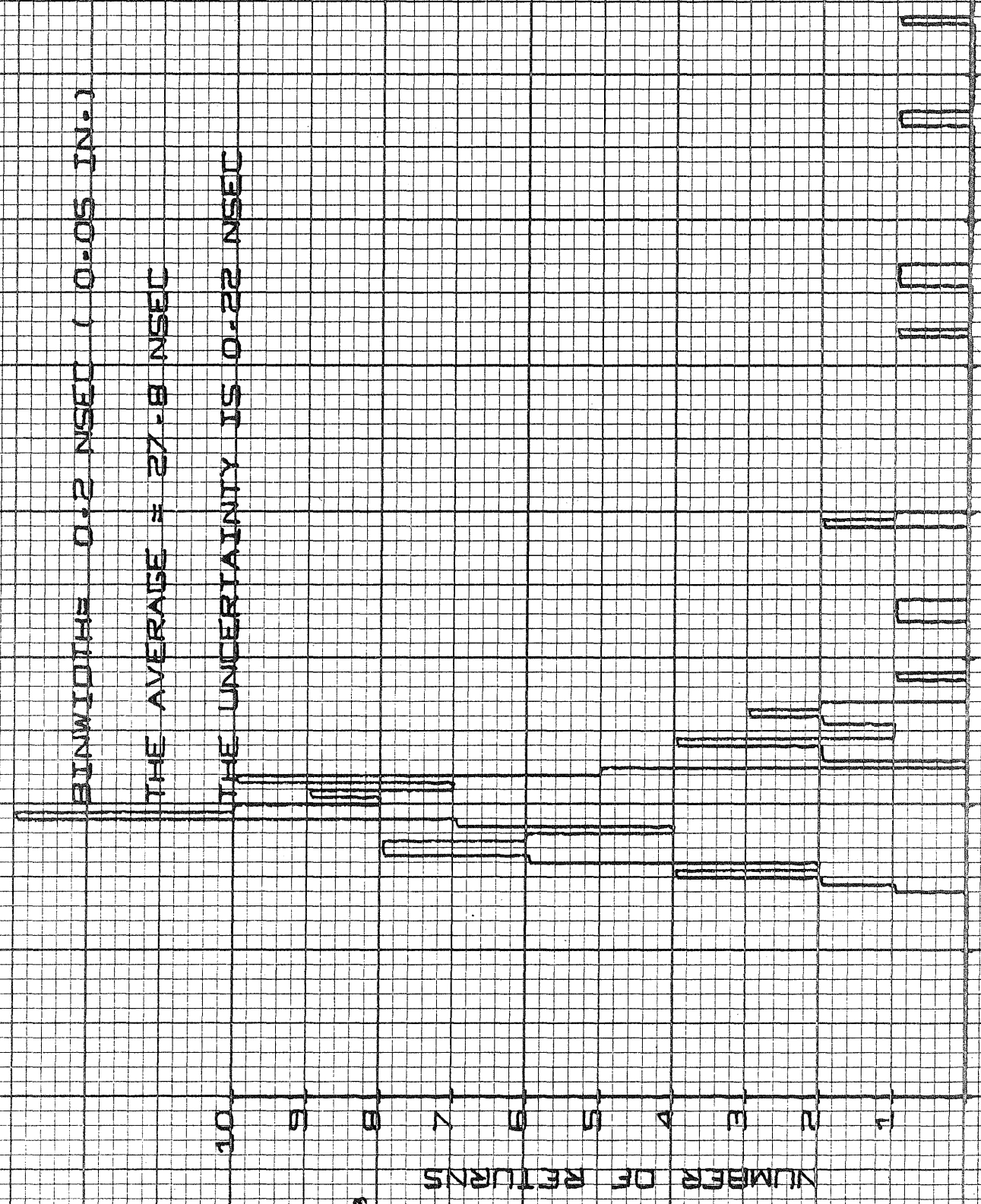

RESIDUALS FROM 20. TO 56. NSEC
1 INCH = 4 NSEC

May 23

Calibration Data (February-March)

<u>Date</u>	<u>A</u>	<u>B</u>	<u>C</u>	<u>D</u>
Feb. 18, 1972 C31034	--	--	--	--
Feb. 20, 1972 Same system	45.4	--	--	416
Feb. 20, 1972 Shorter cable; d is 20	45.6	--	--	418
Feb. 23, 1972 31000F; f is 0.5	39.6	37.4	38.2	351
Feb. 24, 1972 Same system	40.0	39.0	37.8	361
Feb. 26, 1972 Same system	40.0	38.9	--	361
Feb. 28, 1972 Same system	--	38.5	--	371
Feb. 29, 1972 Same system	--	38.4	--	371
March 1, 1972 Same system	--	39.4	40.0	371
March 2, 1972 Same system	40.5	--	--	371
March 3, 1972 Same system	40.5	39.8	40.0	368
March 5, 1972 Same system	--	38.6	39.8	368
March 6, 1972 Same system	--	38.5	39.8	368
March 7, 1972 Same system	--	38.2	39.7	368
March 8, 1972 C31034; d is 3.0, G is 40	45.5	--	--	418

Calibration Data (March-April)

<u>Date</u>	<u>A</u>	<u>B</u>	<u>C</u>	<u>D</u>
March 10, 1972 RC 10 nsec; G=100	46.9		→	432
March 20, 1972 C31034, 2100V; G=200	46.5		→	435
March 22, 1972 31000F, 3000V	47.2		→	442
March 23, 1972 31000F, 3150V; base mod.	42.0		→	390
March 24, 1972 31000F, 3000V; d=1.0	40.0	40.5	39.9 →	370
March 25, 1972 31000F, 3000V; d=0.8	39.9	41.0	40.0 →	371
March 26, 1972 31000F, 3000V; d=1.0	39.0	38.0	40.5 →	376
March 27, 1972 C31034, 1850V; d=1.0 G=100	48.2		→	469
April 3, 1972 Same system	48.8		→	
April 4, 1972 31000F, 2950V; d=1.35	39.5*	38.2*	40.8*	379
April 5, 1972 Same system. Maybe doubles	39.6*	37.2?	39.9?	
April 7, 1972 Same system	39.6			↓
April 8, 1972 C31034, 1850V; G=100 Longer delay cable	52.9		→	513
April 9, 1972 C31034, 1850V; G=100 Longer delay cable	"			"

Calibration Data (April-May)

<u>Date</u>	<u>A</u>	<u>B</u>	<u>C</u>	<u>D</u>
April 17, 1972 31034, 2000V; G=20, d=100	22.0	--	--	218e
April 23, 1972 Same system	22.1	--	--	219e
April 25, 1972 2200V, G=10, d=190, int=5 nanoseconds	21.0	23.9	--	208e
April 27, 1972 Same except longer delay	25.4	29.5	28.6c	257c
April 29 (120) Monsanto cable on	--	30.5*	32.8h	299h
April 30, 1972 Same as April 27th	--	28.8	28.5b	256b
May 1, 1972 Same system	--	28.5	28.2b	253b
May 3, 1972 Same system, less feed- back, FWHM=3, 60 returns	30.2	28.5	28.4b	255b
May 4, 1972 Same system, FWHM=3, 40 returns	--	28.7	27.9b	250b
May 5, 1972 Same system	--	28.8	28.6c	257c
May 6, 1972 Same system	--	29.0	28.4b	255b
May 7, 1972 Same system	30.2	28.8	27.9b	250b
May 9, 1972 Same system	--	29.7	28.2c	253c

*plus or minus 5