



City Research Online

City, University of London Institutional Repository

Citation: Apostolopoulou, D., Sauer, P. W. & Dominguez-Garcia, A. D. (2015). Balancing Authority Area Coordination with Limited Exchange of Information. Paper presented at the 2015 IEEE Power & Energy Society General Meeting, 26-30 Jul 2015, Denver, USA.

This is the accepted version of the paper.

This version of the publication may differ from the final published version.

Permanent repository link: <http://openaccess.city.ac.uk/19822/>

Link to published version:

Copyright and reuse: City Research Online aims to make research outputs of City, University of London available to a wider audience. Copyright and Moral Rights remain with the author(s) and/or copyright holders. URLs from City Research Online may be freely distributed and linked to.

City Research Online:

<http://openaccess.city.ac.uk/>

publications@city.ac.uk

Balancing Authority Area Coordination with Limited Exchange of Information

Dimitra Apostolopoulou, Peter W. Sauer, and Alejandro D. Domínguez-García

Department of Electrical and Computer Engineering
University of Illinois at Urbana-Champaign
Urbana, Illinois 61801
Email: {apostol2, psauer, aledan}@illinois.edu

Abstract—In this paper, we propose a coordination scheme between balancing authority (BA) areas in an interconnected power system that decreases the regulation amount needed as well as the associated costs. Our approach aims at mimicking the behavior of the automatic generation control (AGC) system in a scenario where the whole interconnected system is assumed to be operated by a single BA area. To this end, we modify the area control error (ACE), which is fed into the AGC system of each BA area, and determine the AGC allocation based on a distributed algorithm that identifies the least expensive generators, with the mismatch of the total regulation needed being the only information exchanged between BA areas. We demonstrate the proposed ideas with the 3-machine 9-bus Western Electricity Coordinating Council (WECC) system, and compare the performance of our method with other three existing coordination approaches.

I. INTRODUCTION

Interconnected power systems are divided into several entities referred to as balancing authority (BA) areas (over 90 in North America); these are responsible for maintaining the load-interchange-generation balance within the portion of the system associated with each of them, and supporting system frequency in real time. To this end, each BA area uses a closed-loop control system known as automatic generation control (AGC). The goal of AGC system is to drive the area control error (ACE) to zero, as the ACE represents the deviation from scheduled values of the sum of tie line flows between a BA area and its neighboring areas, and its obligation to support frequency.

The AGC system output is the total shift in generation needed in a BA area to restore the system frequency and the net power interchange to the desired values. This signal is allocated through the AGC market and allocation processes to individual generators participating in regulation. The AGC market process is implemented every hour and determines which resources are cleared, i.e., selected to participate in frequency regulation. Then, the AGC allocation process, which is executed throughout the hour, establishes the actual regulation amount offered by each of the cleared resources.

BA areas are obliged to purchase ancillary services to accommodate variability in load and generation. However, this need will be intensified due to, e.g., deepening penetration of renewable-based generation. Since generation reserves are

limited and expensive, a method that reduces the regulation amount needed would be beneficial for all the BA areas in the interconnection.

When the regulation amount and the cost are determined at the BA area level, the individual AGC systems might cause overregulation, i.e., if all the BA areas were operated as one, then the regulation amount as well as the associated costs would be less. In this context, the area control error diversity interchange (ADI) methodology has been proposed as a means of BA area coordination. The ADI is the pooling of individual ACEs to take advantage of sign differences associated with the momentary load-generation imbalances in each BA area [1]. By pooling ACE, the participants are able to reduce the control burden on individual BA areas, and the sensitivity to resources with potentially volatile output [2]. However, such a coordination scheme fails to reach the optimal solution, which is found when the whole interconnection is operated by one single BA area and the AGC system is implemented in the interconnection level.

Several papers have addressed the problem of developing BA area coordination methods. In [3], the authors describe the secondary and tertiary voltage control systems implemented in the Italian transmission network, and with several case studies indicate the benefits of coordinated regulation. In [4], a modification of the ADI scheme is presented that takes into account the transmission constraints by using sensitivity factors. The authors in [5] propose a decentralized load frequency control system, the goal of which is to obtain robust PI controllers in a multi-area power system.

In this paper, we propose a methodology that mimics the behavior of the AGC system and the associated allocation scheme as if all BA areas were one. In order to do so, we use the individual ACEs of each BA area to approximate the ACE in the scenario where all BA areas are assumed to be a single BA area. Then, we allocate the approximated ACE to the individual AGC systems proportionally to their size. Next, we mimic the AGC allocation for the entire area without the need for exchanging cost information between the BA areas. To this end, we develop a distributed algorithm that provides the same solution as the centralized AGC allocation, with the total mismatch of regulation being the only information exchanged between BA areas.

II. PRELIMINARIES

In this section, we present the models used to develop the proposed coordination scheme, and describe the ADI methodology, which is the BA area coordination methodology currently used in industry.

A. Multi-Area AGC System Model

Let $\mathcal{A} = \{1, \dots, M\}$ be the set of BA areas in an interconnected system, and for each $m \in \mathcal{A}$, let $\mathcal{A}_m \subset \mathcal{A}$ denote the set of BA areas that are directly interconnected to BA area m . Then, the ACE for BA area m is given by

$$\begin{aligned} ACE_m &= \sum_{m' \in \mathcal{A}_m} (P_{mm'} - P_{mm'}^{sch}) - b_m(f_m - f_{nom}) \\ &= \sum_{m' \in \mathcal{A}_m} \Delta P_{mm'} - b_m \Delta f_m, \end{aligned} \quad (1)$$

where $P_{mm'}$ is the real power transfer from BA area m to BA area m' , $P_{mm'}^{sch}$ is the scheduled power transfer from BA area m to BA area m' , b_m is the frequency bias factor, f_m is the system frequency, f_{nom} is the system nominal frequency, $\Delta P_{mm'} = P_{mm'} - P_{mm'}^{sch}$, and $\Delta f_m = f_m - f_{nom}$.

We denote by \mathcal{G}_m the set that indexes all generators in BA area m , and by z_m the sum of the AGC commands sent to generators in BA area m ; then, following [6, pp. 352-355], we have that

$$\dot{z}_m = -z_m - ACE_m + P_G^m, \quad (2)$$

where $P_G^m = \sum_{i \in \mathcal{G}_m} P_{G_i}$, and P_{G_i} is the real power output of generator i .

B. Conventional AGC Allocation Scheme

Resource i in BA area m submits its bid that consists of a capacity offer γ_i^m [\$/MW], a service offer σ_i^m [\$/MW], a capacity amount \bar{a}_i^m [MW], and the automatic response rate ζ_i^m [MW/min]. The resource selection is done every hour in order to minimize expected cost subject to operational constraints, through the AGC market clearing mechanism. Resources are accepted ‘‘all-or-nothing’’, i.e., the bid of each resource may not be partially accepted. Let $\mathcal{S}^m = \{1, \dots, S^m\}$ be the set of cleared resources from the AGC market. The AGC allocation is implemented throughout the hour, and its objective is to allocate z_m to elements in \mathcal{S}^m in order to minimize cost, subject to response time and other operational constraints. The decision variables are the amounts of regulation a_i^m for $i \in \mathcal{S}^m$. The statements above can be formalized as follows:

$$\begin{aligned} &\underset{a_i^m}{\text{minimize}} \sum_{i \in \mathcal{S}^m} a_i^m \sigma_i^m \\ &\text{such that} \quad \sum_{i \in \mathcal{S}^m} a_i^m = \left| z_m - \sum_{j \in \mathcal{G}_m} P_{G_j}^* \right| \\ &\quad \frac{a_i^m}{\zeta_i^m} \leq \rho_t^m, \quad \forall i \in \mathcal{S}^m \\ &\quad 0 \leq a_i^m \leq \bar{a}_i^m, \quad \forall i \in \mathcal{S}^m, \end{aligned} \quad (3)$$

where $P_{G_j}^*$ is the economic dispatch signal of generator j , and ρ_t^m [min] is the response time requirement. The regulation amount needed is set to $|z_m - \sum_{j \in \mathcal{G}_m} P_{G_j}^*|$, since the AGC system determines the total generation needed to restore frequency and the real power interchange to the desired values, and $\sum_{j \in \mathcal{G}_m} P_{G_j}^*$ is the total generation of BA area m following the signals of the most recent economic dispatch process. Thus, the difference in these two quantities is the regulation amount needed. The solution of (3) determines the optimal regulation quantity a_i^{m*} for $i \in \mathcal{S}^m$. The ex-post costs for AGC service for BA area m are

$$c_m = \sum_{i \in \mathcal{S}^m} \left(a_i^{m*} \sigma_i^m + \bar{a}_i^m \gamma_i^m \right). \quad (4)$$

C. Conventional ACE Diversity Interchange Methodology

The ACE diversity interchange (ADI) is defined as the summation of ACEs among the BA areas:

$$ADI = \sum_{m \in \mathcal{A}} ACE_m. \quad (5)$$

We write the BA area set \mathcal{A} as the union of two disjoint subsets: $\mathcal{A} = \mathcal{A}^M \cup \mathcal{A}^\mu$, and assign each BA area m into (i) $m \in \mathcal{A}^M$, if $ACE_m \cdot ADI > 0$, or (ii) $m \in \mathcal{A}^\mu$, if $ACE_m \cdot ADI < 0$ [The set \mathcal{A}^M is referred to as the majority group, whereas \mathcal{A}^μ as the minority group].

For every BA area $m \in \mathcal{A}^\mu$, the adjusted ACE is $ACE_m^a = 0$. Let ADI^μ be the sum of ACEs of the BA areas that belong in the minority group, i.e., $ADI^\mu = \sum_{m \in \mathcal{A}^\mu} ACE_m$. For the BA areas that belong to the majority group, we use the equal allocation method to determine the adjusted ACEs, which results in

$$ACE_m^a = ACE_m + \frac{ADI^\mu}{|\mathcal{A}^M|}, \quad (6)$$

where $|\mathcal{A}^M|$ is the cardinality of the set \mathcal{A}^M . However, the ADI adjustment must not change the sign of ACE. Therefore, we have the following condition:

$$\text{if } \frac{|ADI^\mu|}{|\mathcal{A}^M|} > |ACE_m|, \quad \text{then } ACE_m^a = 0, \quad m \in \mathcal{A}^M. \quad (7)$$

We denote by $\overline{\mathcal{A}}^M$ the set of BA areas that satisfy the condition in (7). In such a case, the remaining amount is redistributed to the other generators in the majority group as follows

$$\begin{aligned} ACE_m^a &= ACE_m \\ &+ \frac{ADI^\mu + \sum_{i \in \overline{\mathcal{A}}^M} ACE_i}{|\mathcal{A}^M| - |\overline{\mathcal{A}}^M|}, \quad m \in \mathcal{A}^M - \overline{\mathcal{A}}^M. \end{aligned} \quad (8)$$

III. PROPOSED SCHEME FOR COORDINATION AMONG BA AREAS

In this section, we describe the proposed BA coordination scheme. We first determine the ACE that is fed to the AGC system of each BA area, and then develop a distributed algorithm to determine the AGC allocation. When considering the entire area as a whole we do not include the sub- or super-script m to ease the notation.

A. Adjusted ACE Determination

Ideally, we would like to implement the AGC system as if the interconnection were comprised of a single BA area, which would be defined as the union of the individual BA areas. In such a case, from (1), the ACE of the combined area would be

$$\begin{aligned}
ACE &= -b\Delta f \\
&\approx \sum_{m \in \mathcal{A}} \left(\sum_{\substack{m' \in \mathcal{A}_m \\ m' \geq m}} \Delta P_{mm'} - \sum_{\substack{m' \in \mathcal{A}_m \\ m' \geq m}} \Delta P_{\text{losses}_{mm'}} \right) \\
&\quad - \sum_{m \in \mathcal{A}} b_m \Delta f_m \\
&\approx \sum_{m \in \mathcal{A}} ACE_m - \sum_{m \in \mathcal{A}} \sum_{\substack{m' \in \mathcal{A}_m \\ m' \geq m}} \Delta P_{\text{losses}_{mm'}} \\
&\approx ADI - \sum_{m \in \mathcal{A}} \sum_{\substack{m' \in \mathcal{A}_m \\ m' \geq m}} \Delta P_{\text{losses}_{mm'}}, \tag{9}
\end{aligned}$$

where $\Delta P_{\text{losses}_{mm'}} = P_{\text{losses}_{mm'}} - P_{\text{losses}_{mm'}}^{\text{sch}}$, i.e., the difference in the losses between BA areas m and m' when the interchange is other than the scheduled. The result in (9) follows from the fact that $\Delta P_{mm'} + \Delta P_{m'm} = \Delta P_{\text{losses}_{mm'}}$, for each $m, m' \in \mathcal{A}$, if BA areas m and m' are electrically connected. If the frequency bias factor is equal to the actual frequency response characteristic (AFRC), then $b = \sum_{m \in \mathcal{A}} b_m$. In this regard, BA areas ideally set the frequency bias factor equal to the AFRC, or to a close value; therefore, we may argue that $b \approx \sum_{m \in \mathcal{A}} b_m$. Moreover, in order for (9) to hold, we make the assumption that $\Delta f = \Delta f_m$, for $\forall m \in \mathcal{A}$, which is reasonable since the system is interconnected, and thus operated under the same frequency.

It follows from (2) that the AGC system for one BA is given by

$$\begin{aligned}
\frac{dz}{dt} &= -z - ACE + P_G \\
&\approx -z - ADI + P_G + \Delta P_{\text{losses}} \\
&\approx -z - ADI + P_G, \tag{11}
\end{aligned}$$

where $\Delta P_{\text{losses}} = \sum_{m \in \mathcal{A}} \sum_{\substack{m' \in \mathcal{A}_m \\ m' \geq m}} \Delta P_{\text{losses}_{mm'}}$. Then, by neglecting ΔP_{losses} , we may approximate the AGC system in each BA area m by

$$\frac{dz_m}{dt} = -z_m - \frac{b_m}{\sum_{m \in \mathcal{A}} b_m} ADI + P_G^m, \quad \forall m \in \mathcal{A}. \tag{12}$$

If we sum up (12) for all $m \in \mathcal{A}$, we obtain (11). Then, the adjusted ACE for BA area m is $ACE_m^a = \frac{b_m}{\sum_{m \in \mathcal{A}} b_m} ADI$. By modifying its ACE, each BA area contributes to some extent to mimic the behavior of the AGC system of the entire area as one BA area. The coefficient $\frac{b_m}{\sum_{m \in \mathcal{A}} b_m}$ is used so that the BA areas participate in the ADI according to their size in terms of capacity and load.

B. AGC Allocation Distributed Algorithm

Another issue arising from the proposed BA area coordination scheme is how each z_m is allocated among the regulating units in the BA areas. In the case where we consider all the BA areas as one, we would solve (3) for one area. We may modify the formulation in (3) as follows

$$\begin{aligned}
&\text{minimize } \sum_{a_i^m} \sum_{m \in \mathcal{A}} \sum_{i \in \mathcal{S}^m} a_i^m \sigma_i^m \\
&\text{such that } \sum_{m \in \mathcal{A}} \sum_{i \in \mathcal{S}^m} a_i^m = b \\
&\quad 0 \leq a_i^m \leq \bar{a}_i^m \quad \forall m \in \mathcal{A}, i \in \mathcal{S}^m,
\end{aligned} \tag{13}$$

where $b = |z - \sum_{m \in \mathcal{A}} \sum_{j \in \mathcal{G}_m} P_{G_j}^*|$, $\rho_t = \min\{\rho_t^m : m \in \mathcal{A}\}$, and $\bar{a}_i^m = \min\{\zeta_i^m \rho_t, \bar{a}_i^m\}$, $\forall m \in \mathcal{A}, i \in \mathcal{S}^m$. We introduce barrier functions to capture the effect of the inequality constraints (see, e.g., [7]), and reformulate the problem as

$$\begin{aligned}
&\text{minimize } \sum_{a_i^m} \sum_{m \in \mathcal{A}} \sum_{i \in \mathcal{S}^m} \left(a_i^m \sigma_i^m - \mu_n \log(a_i^m) - \right. \\
&\quad \left. \mu_n \log(\bar{a}_i^m - a_i^m) \right)
\end{aligned} \tag{14}$$

$$\text{such that } \sum_{m \in \mathcal{A}} \sum_{i \in \mathcal{S}^m} a_i^m = b \iff \lambda,$$

where μ_n is a positive sequence, with $\mu_n \rightarrow 0$, as $n \rightarrow \infty$, e.g., $\mu_n = \frac{1}{10^n}$. It then follows that the Lagrangian of (14) is given by

$$\begin{aligned}
\mathcal{L}(a, \lambda) &= \sum_{m \in \mathcal{A}} \sum_{i \in \mathcal{S}^m} \left(a_i^m \sigma_i^m - \mu_n \log(a_i^m) \right. \\
&\quad \left. - \mu_n \log(\bar{a}_i^m - a_i^m) \right) + \lambda \left(\sum_{m \in \mathcal{A}} \sum_{i \in \mathcal{S}^m} a_i^m - b \right), \tag{15}
\end{aligned}$$

where $a = \{a_i^m : \forall m \in \mathcal{A}, i \in \mathcal{S}^m\}$. According to [8, p. 243], we may add the term $\frac{1}{2}(\sum_{m \in \mathcal{A}} \sum_{i \in \mathcal{S}^m} a_i^m - b)^2$ to the Lagrangian function and solve an equivalent problem. In order to solve (14) distributively we use the saddle point dynamics for (15) (see [9]), which is given by

$$a[k+1] = a[k] - \gamma \mathcal{L}_a(a, \lambda), \tag{16}$$

$$\lambda[k+1] = \lambda[k] + \gamma \mathcal{L}_\lambda(a, \lambda), \tag{17}$$

where $\gamma > 0$ is the stepsize and $\mathcal{L}(\cdot)$ is the partial derivative of \mathcal{L} with respect to the argument in the subscript. The only restriction in the initial conditions is that $0 < a_i^m[0] < \bar{a}_i^m$ for all $m \in \mathcal{A}, i \in \mathcal{S}^m$, and $\lambda[0] < 0$. The authors in [9] show that $a[k]$ and $\lambda[k]$ converge to the optimal values, i.e., $a \rightarrow a^*$, and $\lambda \rightarrow \lambda^*$; therefore, the distributed algorithm reaches the optimal solution of (14). We develop the expressions given in (16)-(17), and obtain the distributed algorithm shown in (17)-(18) (see top of next page).

So far, we have established that the total ex-post regulation costs c are minimized, and are equal to

$$c = \sum_{m \in \mathcal{A}} \sum_{i \in \mathcal{S}^m} (a_i^{m*} \sigma_i^m + \bar{a}_i^m \gamma_i^m). \tag{19}$$

$$a_i[k+1] = \begin{cases} 0 & , & a_i[k] \leq 0 \\ \bar{a}_i & , & a_i[k] \geq \bar{a}_i \\ a_i[k] - \gamma \left(\sigma_i + \lambda[k] + \left(\sum_{m \in \mathcal{A}} \sum_{i \in \mathcal{S}^m} a_i - b \right) - \mu_n \frac{1}{a_i} + \mu_n \frac{1}{\bar{a}_i - a_i} \right) & , & \text{otherwise} \end{cases}, \quad (17)$$

$$\lambda[k+1] = \lambda[k] + \gamma \left(\sum_{m \in \mathcal{A}} \sum_{i \in \mathcal{S}^m} a_i - b \right). \quad (18)$$

Another issue is how much each BA area contributes to the cost. One way to do so is by allocating it proportionally to the ACE of each area. Then, we have that the ex-post regulation costs of BA area m , c_m , are given by

$$c_m = \frac{|ACE_m|}{\sum_{m \in \mathcal{A}} |ACE_m|} c. \quad (20)$$

Such an allocation is fair in the sense that the BA areas with larger ACE pay more than those that have smaller ACE. The ACE ideally represents the MW amount that needs to be provided to restore the system frequency to the nominal value. Therefore, BA areas with a large ACE need to provide a large regulation amount. For the BA areas that procure the largest regulation amount, they still pay less than what they would pay if no coordination were present. Thus, they have incentive to coordinate with the other BA areas.

IV. NUMERICAL EXAMPLES

In this section, we illustrate the proposed coordination scheme with the standard 3-machine 9-bus Western Electricity Coordination Council (WECC) power system model (see Fig. 1), which contains three synchronous generating units in buses 1, 2 and 3, and three loads in buses 5, 6 and 8 (machine, network and load parameter values may be found in [10]). We consider two BA areas, as depicted in Fig.1; thus, $\mathcal{A} = \{1, 2\}$. Unless otherwise noted, all quantities in this section are expressed in per unit (pu) with respect to a base power of 100 MVA. We calculate the total MW amount of regulation and the total ex-post regulation costs by using four methods: (M1) the proposed BA coordination scheme, as described in Section III, (M2) the method where the AGC system is implemented in $\{1 \cup 2\}$ as one single BA area, (M3) the method where each BA area employs its own AGC system

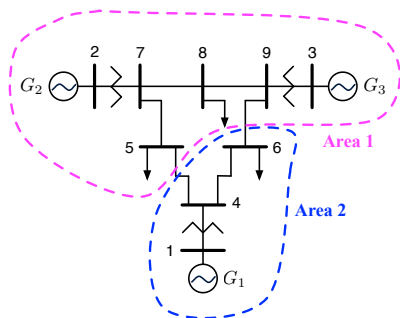

Fig. 1: One-line diagram of the 3-machine 9-bus WECC power system.

Resource	\bar{a}_i [MW]	γ_i [\$/MW]	σ_i [\$/MW]	ζ_i [MW/min]
1	20	1	1	1
2	10	2	3	2
3	25	3	5	3

TABLE I: Bids of Generators 1, 2, and 3.

and no coordination is present, and (M4) the ADI methodology given in Section II-C.

We modify the load at bus 5, which belongs in BA area 2, as follows $P_{L_5} = P_{L_{5_0}} - 0.15$, where $P_{L_{5_0}}$ is the initial load equal to 1.25 pu. In a similar way, we modify the load at bus 6, which belongs in BA area 1, as $P_{L_6} = P_{L_{6_0}} + 0.17$, with $P_{L_{6_0}} = 0.9$ pu. The three generators that belong to \mathcal{A} participate in regulation, and their bids are given in Table I. The operational constraints used in M2 are: the capacity requirement is 30 MW, and the response time requirement is $\rho_t = 20$ min. For M1, M3, and M4 we have: the capacity requirements are 20 MW, and the response time requirements are $\rho_t^1 = \rho_t^2 = 20$ min. From the AGC market, the set of cleared resources is $\{1, 2\}$ for M2, and $\{1, 2, 3\}$ for M1, M3, and M4. We compare the ex-post costs incurred and the total regulation amount for the four aforementioned methods; the results are given in Table II.

We notice that the optimal solution is provided by M2, i.e., when we consider the entire system as one BA area, since the regulation amount as well as the costs are minimum. At the initial steady state the flows in lines (5, 4) and (9, 6), which connect BA areas 1 and 2, were -0.4198 pu and 0.5776 pu, respectively. So, the scheduled power flow between the BA areas is $P_{12}^{sch} = 0.1578$ pu. After the modifications in loads at buses 5, and 6, the difference in the real power interchange is $P_{12}^{M1} = 0.1520$ pu for M1, $P_{12}^{M2} = 0.1521$ pu for M2, $P_{12}^{M3} = 0.1578$ pu for M3, which is equal to the actual schedule, and $P_{12}^{M4} = 0.1610$ pu for M4. So, the AGC commands with M1, M2, and M4 create similar flows between the two BA areas. That is not achieved with M3, where no coordination is present. The reason is that the ACE value includes the real power interchange, and the AGC system goal is to make the ACE zero. In M1 and M4, since the

method	M1	M2	M3	M4
cost of BA area 1	2.1571	–	49.8469	6.1123
cost of BA area 2	2.1557	–	20.1061	2.3058
ex-post cost	4.3128	4.2308	70.0680	8.4181
regulation amount	4.1978	4.1908	36.7212	4.2674

TABLE II: Ex-post costs and regulation amounts for the four methodologies.

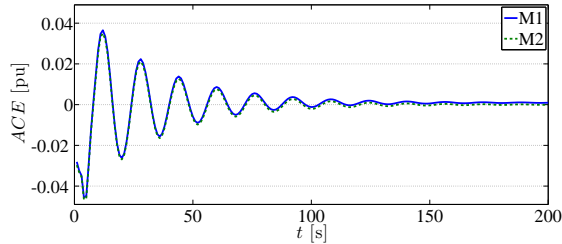

Fig. 2: Area Control Error with M1 and M2.

adjusted ACE is determined by an addition of the individual ACEs, such an event is not observed. We also notice that $|P_{12}^{M2} - P_{12}^{M1}| < |P_{12}^{M2} - P_{12}^{M4}|$; which explains why M1 provides a smaller amount of regulation than M4. The reason is that the ACE of each BA area in M1 is obtained by considering the ACE of the BA areas as a whole, as described in detail in Section III-A. We depict in Fig. 2 the ACE with M2 and the addition of the adjusted individual ACEs of BA areas 1 and 2, as determined by M1, and notice that they are very close to each other.

We also see from Table II that the minimum cost is achieved by using M2. In this case, only Generator 1 is used in regulation since the load imbalance is not larger than 0.2 pu, which is the capacity limit of resource 1, and the ramping requirements are met. However, in M3, where no coordination is present, all generators participate in regulation, instead of only the least cost one. In M4, the adjusted ACE, due to the sign differences between ACE in BA area 1 and 2, has a lower in magnitude value than the load variations; thus in BA area 1, only Generator 2 is needed in regulation. Therefore, the entire system only uses Generators 1 and 2 for regulation. Generator 2 is more expensive than Generator 1, but since the ADI method does not provide the option of exchanging regulation amounts between BA areas, Generator 2 is needed to provide regulation. In M1, only Generator 1 is utilized, since the distributed algorithm, given in Section III-B, provides the same results as the centralized AGC allocation scheme. For example, at one time instant where the total regulation needed is 2 MW, the regulation amounts converge to the values: $a_1^2 = 2$ MW, $a_2^1 = 0$ MW, and $a_3^1 = 0$ MW, as depicted in Fig. 3. The total cost is distributed among the BA areas, based on the coefficients presented in Fig. 4.

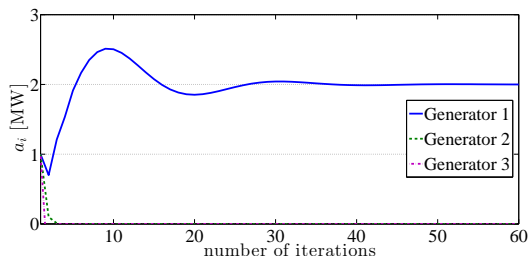

Fig. 3: Regulation amount provided by each resource i .

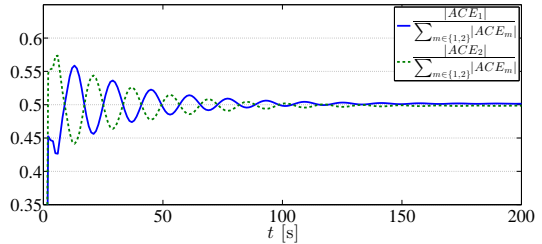

Fig. 4: Ratios of BA areas 1 and 2 for regulation cost distribution.

V. CONCLUDING REMARKS

In this paper, we proposed a coordination scheme between BA areas of an interconnected system, which aimed at approximating the solution that would result from using a single AGC system and allocation for the whole interconnected system. More specifically, we used the individual ACEs of each BA area to approximate the ACE in the scenario where all BA areas were assumed to be a single BA area, and distributed it into each AGC subsystem accordingly. Next, we developed a distributed algorithm that minimizes the cost of regulation, by allocating the AGC command from the least to the most expensive generator sequentially, until all the regulation amount is met, without exchanging any cost information.

We demonstrated via numerical examples how the proposed method works, and compared its performance with other three methods. We also showed that the proposed BA coordination scheme provides a good approximation of the optimal solution, i.e., if all BA areas were under the same jurisdiction, and respects that each BA area wants to keep certain information from other BA areas.

REFERENCES

- [1] A. R. Oneal, "A simple method for improving control area performance: area control error (ACE) diversity interchange ADI," *IEEE Transactions on Power Systems*, vol. 10, no. 2, pp. 1071–1076, May 1995.
- [2] (2014, Accessed March) Reliability guideline: ACE diversity interchange. [Online]. Available: <http://www.nerc.com>
- [3] S. Corsi, M. Pozzi, C. Sabelli, and A. Serrani, "The coordinated automatic voltage control of the Italian transmission Grid – Part I: Reasons of the choice and overview of the consolidated hierarchical system," *IEEE Transactions on Power Systems*, vol. 19, no. 4, pp. 1723–1732, November 2004.
- [4] N. Zhou, P. Etingov, Y. V. Makarov, R. T. Guttromson, and B. McManus, "Improving area control error diversity interchange (ADI) program by incorporating congestion constraints," in *2010 IEEE PES Transmission and Distribution Conference and Exposition*, April 2010, pp. 1–8.
- [5] H. Bevrani, Y. Mitani, and K. Tsuji, "Robust decentralised load-frequency control using an iterative linear matrix inequalities algorithm," *IEEE Proceedings on Generation, Transmission and Distribution*, vol. 151, no. 3, pp. 347–354, May 2004.
- [6] A. Wood and B. Wollenberg, *Power Generation, Operation, and Control*. New York, NY: Wiley, 1996.
- [7] I. Griva, S. G. Nash, and A. Sofer, *Linear and Nonlinear Optimization: Second Edition*. Philadelphia, Society for Industrial and Applied Mathematics (SIAM), 2009.
- [8] D. P. Bertsekas and J. N. Tsitsiklis, *Parallel and Distributed Computation: Numerical Methods*. New Hampshire, Athena Scientific, 1997.
- [9] K. J. Arrow, *Studies in Linear and Non-Linear Programming*, ser. Stanford mathematical studies in the social sciences. Stanford University Press, 1958.
- [10] P. W. Sauer and M. A. Pai, *Power System Dynamics and Stability*. Upper Saddle River, NJ: Prentice Hall, 1998.