



DOI: 10.5281/zenodo.1048241

A REVIEW ON THE STUDY OF HISTORICAL STRUCTURES USING INTEGRATED INVESTIGATION ACTIVITIES FOR SEISMIC SAFETY ASSESSMENT. PART I: DYNAMIC INVESTIGATION

Ahmed Elyamani¹ and Pere Roca²

¹*Department of Archaeological Conservation, Faculty of Archaeology, Cairo University, Giza, Egypt*

²*Department of Civil and Environmental Engineering, Technical University of Catalonia, Barcelona, Spain*

Received: 05/08/2017

Accepted: 30/10/2017

Corresponding author: Ahmed Elyamani (a_elyamani@cu.edu.eg)

ABSTRACT

Assessment of seismic safety of historical structures is a challenging task because the information available about the assessed structure is usually limited. Therefore, it is often necessary to exploit a number of integrated investigation activities to increase the level of knowledge about the historical structure under consideration. Thus, in the case of any need for providing the structure with strengthening intervention, this intervention will be a minimal and any unnecessary strengthening operations will be avoided. This paper presents a literature review carried out to cover the current state-of-the-art of a number of investigation activities carried out integrally for the seismic safety assessment of historical structures. It is presented in two parts. In this first part, the covered topic is the dynamic investigation of historical structures which includes the dynamic identification tests, the dynamic monitoring, and the modal parameters identification methods with the classical and the advanced techniques like the peak picking and the stochastic subspace identification.

KEYWORDS: Historical Structures, Seismic Assessment, Dynamic Identification, Dynamic Monitoring

1. INTRODUCTION

Historical structures are very important elements of the world heritage as cultural resources involving important artistic, spiritual, technical and scientific merits. They contribute to the identity of cultures and countries and provide valuable documents on the great achievements from the past. Moreover, they represent important economic resources and can contribute very significantly to economic development. For instance, in 2012 the tourists that visited Spain generated an income of about 55608 million € (Ministry of industry, energy and tourism, 2012). It is interesting to find that more than the half of those tourists came for cultural interests (Ministry of industry, energy and tourism, 2012). More specifically, in the same year and, for the region of Andalusia (south of Spain), known for its rich cultural heritage, the income from cultural tourism was around 3000 million € (Government of Andalusia, 2013). In the same year, an important monument, the Alhambra of Granada, produced alone about 25 million € (Board of the Alhambra and Generalife, 2012).

For these reasons and many others, modern societies allocate great technical and economical effort to the conservation of their architectural heritage. Nevertheless, the preservation of the architectural heritage faces significant challenges ranging from the difficulty in understanding the historical construction materials to the complexity of possible actions influencing on it. It is needless to say that adopted criteria in modern codes are hardly applicable to such class of buildings.

Moreover, conservation of historical structures faces the challenge meant by the fact that a large part of the world heritage is located in seismic regions, including Italy, Greece, Turkey, and China, among other countries with abundant architectural heritage. A large number of master pieces of human heritage structures have been destroyed by catastrophic earthquakes. Due to the earthquake of Lisbon 1755, the two thirds of the city became uninhabitable, and about 35 churches, 65 convents, 33 palaces, the Royal library, the Patriarchal Palace and the Arsenal were ruined (Pereira, 2009). More recently, the inspections carried out immediately after the L'Aquila 2009 earthquake revealed that more than 50% of the cultural heritage buildings were in critical conditions and could not be used (Dolce, 2009). Obviously, historical structures need to be seismically assessed and protected in order to ascertain its survival in the long term.

When assessing the seismic safety of a historical structure, the first problem to face, in many cases, is the limited information available about the different aspects of the structure (construction history, used

construction techniques, collapses due to previous seismic events, etc.). In order to overcome these limitations, a successful assessment approach should be based on combining and making use of the different investigation activities that may increase the level of knowledge about the historical structure. These activities include, among other possibilities, the historical investigation, the inspection (including laboratory and in-situ experiments), the monitoring and the structural analysis. These activities are used for gathering sufficient information about the assessed structure which may significantly contribute, through a better understanding of the features and problems of the building, to design a minimal intervention and avoid unnecessary strengthening operations. This knowledge can be obtained by using different investigation activities oriented to obtain enough and meaningful information on the local and the global levels of the historical structure.

On the local level, it is possible to use non-destructive test (NDT) and/or minor-destructive tests (MDT) (flat jack test, GPR, tomography, etc.) that may offer valuable information. However, the obtained information is correct only for the limited locations of these tests and if no sufficient number of tests is carried out to reflect the variability in the used materials, the results may be statistically not relevant. In addition, some local tests, such as coring, might not be allowed to preserve the integrity of the structure. Therefore, it is essential to use global inspection techniques like dynamic identification tests and different types of monitoring that may be able to provide knowledge about the global behavior of the structure. Monitoring, in specific, may contribute to a better understanding of the present structural behavior under different normal and exceptional actions

This research aims at providing a state-of-the-art review on the seismic safety assessment of historical structures using some selected integrated investigation activities. It is presented in two-part paper. In the first part, the reviewed items are the dynamic identification of historical structures, the dynamic monitoring of historical structures, and the modal parameters identification. In the second part, the updating of finite element models of historical construction, the historical masonry properties and finally the seismic assessment of historical structures are discussed.

2. DYNAMIC IDENTIFICATION OF HISTORICAL CONSTRUCTION

2.1 Motivations

Dynamic investigation of structures, whether modern or historic, includes two interconnected ac-

tivities: dynamic identification and dynamic monitoring. Usually before installing a dynamic monitoring system in a structure, dynamic identification tests are first carried out. In some cases, due to economic reasons for instance, only the first activity is performed and can provide acceptable insight about the dynamic characteristics of the structure under study. The dynamic investigation of modern civil engineering structures started long time before the systematic investigation on historical structures. Therefore, a brief about the motivations for dynamic investigation of this type of structures is first given. Then, the objectives of performing dynamic identification of historical structures are discussed. In a following section, the dynamic monitoring of historical structures is discussed.

In recent decades, interest in the dynamic performance of civil engineering structures has increased significantly with the inevitable trend towards taller, longer, more slender, and more light weight structures that are increasingly vulnerable to dynamic excitation. Such excitation can arise from a wide variety of sources, such as earthquakes, wind, traffic, and human activities. Also, it is becoming increasingly important to guarantee that the structure dynamic response is adequate for many reasons like improving comfort for human occupants under the effect of wind oscillations in service, or ascertaining a satisfactory strength performance under the effect of earthquakes and hurricane wind. As a result, there is a clear need to carry out dynamic investigations of a wide range of structures to characterize accurately their inherent structural dynamic properties and to understand better their response to real-world actions. So far, the key reasons for dynamic investigation of modern structures seem to be the following: to test and/or monitor existing structures to find out whether their performance falls within particular criteria (performance evaluation); to monitor existing structures to detect signs of damage or deterioration (structural health monitoring); to carry out testing/monitoring on a research basis to understand better the dynamic properties and performance and consequently propose guidance for improved future modeling and/or design; and to troubleshoot existing structures that have shown to be problematic (Reynolds, 2008).

When moving to historical structures, dynamic identification tests are carried out to achieve some or all of the following aims (D10.4-NIKER, 2012): 1) to obtain information on the global dynamic behavior of the structure, including natural frequencies, mode shapes and damping coefficients, 2) to validate and update a structure's numerical model by comparing experimental and numerical natural frequencies and mode shapes, 3) to assess the level of connection be-

tween different parts. In specific, assess the level of connection between parts partially separated by cracks, 4) to identify weak structural features, 5) to appraise the influence of major damage on the structural response, 6) to evaluate the effect of possible repair and strengthening solutions by comparing the dynamic parameters before and after the intervention and hence improving the design for future applications in other similar structures, 7) to allow monitoring before (diagnosis phase) and after the intervention (post-intervention control phase) by repeating periodically the dynamic tests and comparing the results, and 8) to help in the optimal selection of strategic locations of sensors for the following activity, if needed, of dynamic monitoring.

2.2 Testing methods

To experimentally identify the dynamic characteristics of a structure, two methods are available: Forced Vibration Testing (FVT) and Ambient Vibration Testing (AVT) (Cantieni, 2005). In this section, the two methods are referred and a comparison between both is provided.

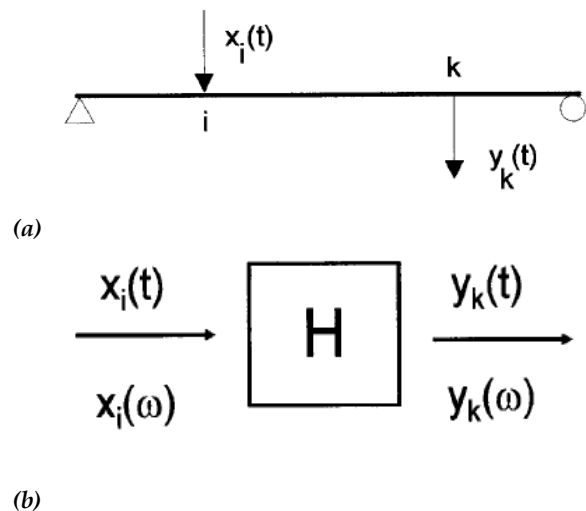

Figure 1. Basics of FVT: (a) testing scheme; and (b) calculation of the Frequency Response Matrix H (Cantieni, 2005).

In Forced Vibration Testing (FVT) the structure is artificially excited with a forcing function $x_i(t)$ in a point i and its response $y_k(t)$ at point k to this excitation is measured together with the forcing function, Figure 1 (a). Transformation of these time signals into the frequency ω domain and calculation of all Frequency Response Functions (FRF's) between the response and the forcing function time signals yields the Frequency Response Matrix H , Figure 1(b). This matrix contains all the information necessary to determine the dynamic natural properties of the structure (natural frequencies, mode

shapes and damping coefficients). The test can be done by keeping the excitation point constant and move the response points over the structure or vice versa. Because it is not so easy to move the exciters used in civil engineering investigations, the first method is preferred. In mechanical engineering, where the structures to be tested are comparatively smaller and easy to excite, e.g. with a hammer, the second method is more common (Cantieni, 2005).

Since the first practical applications until now, the testing equipment and the algorithms for data processing have evolved significantly. As a result, it is currently a well-established field founded on solid theoretical bases extensively documented in reference books and largely used in practice, particularly in aerospace and automotive industries. A lot of relevant applications are documented in the issues of the Mechanical System and Signal Processing Journal (MSSP) published during the last 25 years and in the proceedings of the International Modal Analysis Conference (IMAC), an annual conference organized since 1982 (Magalhães and Cunha, 2011). For more about FVT, interested reader may refer to Heylen and Sas (2006); Ewins (2000a); Ewins (2000b); Maia and Silva (1997); McConnell and Varoto (1995).

In Ambient Vibration Testing (AVT), no artificial excitation is used. Instead, the response of the structure to ambient excitation is measured. For civil engineering structures, ambient excitation can be wind, traffic, seismic micro-tremors, etc. The more broadband the ambient excitation is, the better the results are. Otherwise, there is some risk that not all natural frequencies of the structure are excited. Compared with the FVT, the information resulting from the force input signal $x_i(t)$ with FVT method is replaced with the information resulting from the response signal $y_R(t)$ measured in a reference point R then the matrix H is calculated, Figure 2(a). Concerning response measurement requirements, the same basic rules apply as for FVT investigations. It is wise to use more than one reference point unless the structure to be tested is very simple. If response measurements are three-dimensional, at least one 3D-point has to be chosen as a reference. The risk of the reference point sitting in the node of a mode can be reduced significantly by choosing more than one reference point. As a rule of thumb, the length of the time windows acquired should be 1000 to 2000 times the structure's fundamental period (Cantieni, 2005).

AVT permits the dynamic assessment of structures without disturbing their normal operation. Furthermore, as structures are characterized using real operation conditions, in case of existence of non-linear behavior, the obtained results are associated with realistic levels of vibration and not with arti-

cially generated vibrations, as it is the case when FVT is used. Nevertheless, as the level of excitation is low, very sensitive sensors with very low noise levels have to be used and even so, one should expect much lower signal to noise ratios than the ones observed in FVT (Magalhães and Cunha, 2011).

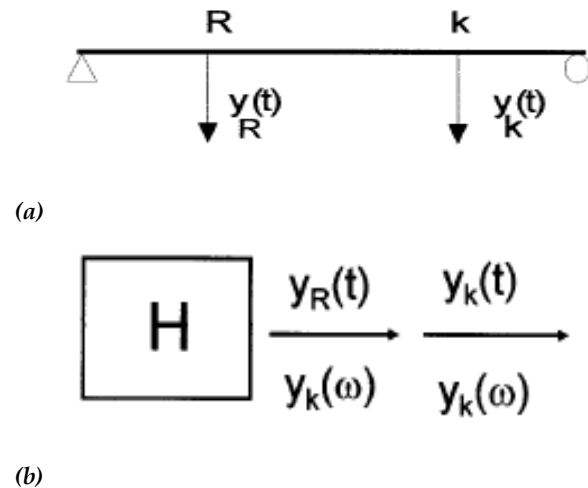

Figure 2. Basics of AVT: (a) testing scheme (R is a reference point and k is a roving point); and (b) calculation of the cross relationship between R and k signals (Cantieni, 2005).

In AVT the modal information is derived from structural responses (outputs) while the structure is in operation. Therefore, this identification process is usually called operational modal analysis (OMA) or output-only modal analysis. As the knowledge of the input is replaced by the assumption that the input is a realization of a stochastic process (white noise), the determination of a model that fits the measured data is also named stochastic system identification (Magalhães and Cunha, 2011). The first software package to extract modal parameters from AVT investigations was developed in the early nineties of the last century. Today, there are several packages on the market making use of the frequency domain procedures shown schematically in Figure 2(b). However, the most recent signal processing tools are not based on an analysis in the frequency domain but alternatively in the time domain. Stochastic Subspace Identification (SSI) is a method working completely in the time domain. Basically, a multi-order model is looked for which synthesizes the measured time signals in an optimum way. This method has especially been developed for AVT investigations (Cantieni, 2005). Detailed information about identification of structure modal parameters is given in section 4.

The main advantage of FVT is the fact that this method provides scaled results. Because the input

force is measured, information on the mass and stiffness matrices of the structure is gathered. In AVT, modal masses are not estimated, or mode shapes are not scaled in absolute sense, unless additional tests with extra masses over the structure are performed (Cantieni, 2005 and Parloo et al., 2002). This allows automated updating of finite element models in case of FVT, whereas; model updating using the results of an AVT investigation is possible with manual techniques only (Cantieni, 2005). AVT has a disadvantage that the frequency content of the excitation may not cover the whole frequency band of interest, especially in the case of very stiff structures with high natural frequencies (Parloo et al., 2002). In AVT, the expected range of acceleration values is 10^{-7} g to 10^{-4} g and this low level of excitation only gives relevant information on the elastic behaviour of the structure (Michel et al., 2008). Also, in AVT ambient excitation being non-controllable usually results in a lack of stationary. This may lead to problems due to the non-linearity of the structure. In case of the excitation amplitude being significantly different for each of the setups, a certain scatter in the results may occur. This is not the case for FVT where the structural vibrations induced can be kept stationary (Cantieni, 2005). In historical masonry structures, the existence of cracks is an important source of non-linearity in dynamic behavior even under low excitation levels.

Table 1. AVT versus FVT (adapted from Dai et al., 2013).

Method	Advantages	Limitations
AVT	<ul style="list-style-type: none"> - Few equipments and operators - Quick and cheap - Tests realized while structure is in service 	<ul style="list-style-type: none"> - Excitation input unknown - Insufficient excitation of modes - Stationary white noise excitation assumption - Heavy noise treatment in data processing
FVT	<ul style="list-style-type: none"> - Better signal to noise ratio - Control of input - Excitation of many modes - More accurate results 	<ul style="list-style-type: none"> - Heavy equipment - Expensive - Time consuming

The main advantage of AVT is the fact that no artificial excitation is necessary. This makes such tests comparatively cheap. In addition, AVT investigations can be performed without embarrassing the normal user. This fact is very important for certain structures like highway bridges. In AVT, the excitation is of the so-called multiple-input type. Wind, traffic, micro-tremors, etc are acting on many points of a structure at the same time. In the contrary, a forced vibration is usually of the single-input type. For small structures, this difference is not important. For large and complex structures, AVT has hence an

advantage on the excitation side (Cantieni, 2005). See also Brincker et al. (2003a) for advantages of AVT. Summarizing, Table 1 provides a comparison between the pros and cons of the two methods: AVT and FVT.

2.3 Equipment

2.3.1 Excitation Mechanisms

The excitation can be induced by an impulse hammer in small and medium-size structures, Figure 3 (a). This device has the advantage of providing a wide-band input that is able to stimulate different modes of vibration. The main drawbacks are the lack of energy to excite some relevant modes of vibration and the relatively low frequency resolution of the spectral estimates which can preclude the accurate estimation of modal damping factors. As a result and specifically designed to excite bridges, some laboratories have built special impulse devices, Figure 3 (b). An alternative, is the use of large electrodynamic shakers (Figure 3 (c)), which can apply a large variety of input signals (random, multi-sine, etc.). The shakers have the capacity to excite structures in a lower frequency range and higher frequency resolution. The possibility of applying sinusoidal forces allows for the excitation of the structure at resonance frequencies and, consequently, for a direct identification of mode shapes (Cunha and Caetano, 2006).

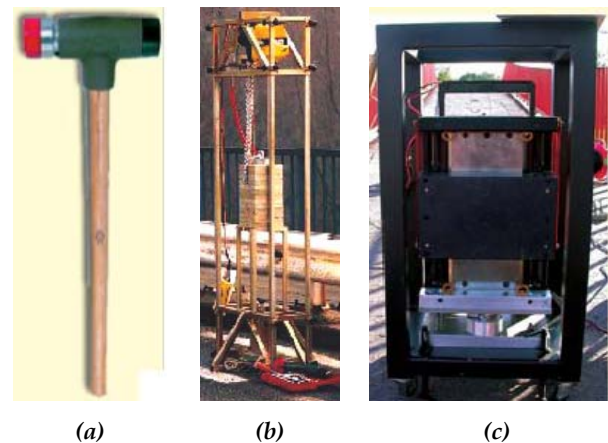

Figure 3. Excitation mechanisms: (a) Impulse hammer; (b) impulse excitation device for bridges (K.U. Leuven); and (c) electrodynamic shaker over three load cells (adapted from Cunha and Caetano, 2006).

Some of other references that give more details on the subject are Pusey (2008) who follows the development of excitation mechanisms since the 50's; Carne and Stasiunas (2006) examine some common and not so common excitation techniques like projectile impacts, explosive inputs, step relaxation, and base excitation; De Silva (2007) provides a guiding

on how to choose a shaker for a certain application; Underwood and Keller (2008a; 2008b) discuss newly developed multi shaker for testing large structures and Salawu and Williams (1995) reviews the state-of-the-art on the excitation techniques of bridges.

2.3.2 Accelerometers

Accelerometers are specific types of sensors. A sensor is a device that converts the physical variable input, like acceleration in case of accelerometers, into a signal variable output, like current, voltage, light, etc. The output signal variables can be manipulated in a transmission system (electrical or mechanical circuit) and then transmitted to a recording device (data acquisition system) (Eren, 1999).

Accelerometers can be classified in a number of ways, for instance, deflection or null-balance types, mechanical or electrical types, dynamic or kinematic types. A large number of practical accelerometers, in specific those used in vibration and shock measurements, are deflection types. The general configuration of this type is shown in Figure 4. As can be seen, the seismic mass is suspended by a spring or cantilever inside a rigid frame which is connected to the vibrating structure. When vibrations take place, the mass tends to remain fixed so that relative displacements can be measured. They are manufactured in many different types and sizes and they exhibit diverse characteristics. Although their principles of operation are similar, they only vary in minor details, such as the spring elements used, types of damping provided, and types of relative motion transducers employed (Eren, 1999). Interesting information about the history of evolution of accelerometers is given by Walter (1997, 1999 and 2002). Recently, Moreno-Gomez et al. (2017) presented a state-of-the-art review of the different sensing technologies and types of sensors used in dynamic identification and monitoring of civil and historical structures.

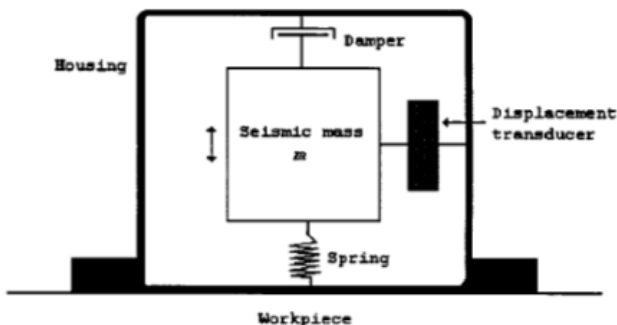

Figure 4. A typical deflection-type seismic accelerometer (adapted from Eren, 1999).

In deciding the accelerometer to be used for a certain application, the following characteristics should

be considered. The frequency range: it is the range in which the accelerometer is useful for vibration measurement (Sinha, 2005). As a rule of thumb, the upper frequency limit for the measurement can be set to 1/3 of the accelerometer's resonance frequency such that the measured vibrations will be less than 1 dB in linearity (Eren, 1999). Linearity is defined as the accuracy of the measured acceleration amplitude in the measuring frequency range (Sinha, 2005). The lower measuring frequency limit is determined by the low-frequency cut-off of the associated preamplifiers, and the effect of ambient temperature fluctuations to which the accelerometer would be sensitive (Eren, 1999). The accelerometers specifications sheet should have a typical frequency response curve illustrating how the accelerometer's accuracy varies over a specified frequency range (Lent, 2009).

The dynamic range: it is the difference between the smallest and largest accelerations that can reliably be measured by the accelerometer. The dynamic range of the accelerometer should match the high or low acceleration levels of the tested/monitored structures (Eren, 1999). The sensitivity: it relates the electrical signal (often in Voltage (V)) to the amplitude of vibration in acceleration (Sinha, 2005). Ideally, the higher the accelerometer sensitivity, the better; but trade-offs might have to be made for sensitivity versus mass (Eren, 1999). Higher sensitivity is achieved by using a softer mass-spring system that generates greater output at lower accelerations levels, nevertheless; the cost is having a lower resonance frequency. If the softer system is accomplished by increasing the mass, the accelerometer will be heavier. Higher sensitivity accelerometers tend to be unacceptably nonlinear at higher levels of acceleration because of the higher stresses on the sensor (Wilson, 1999b). As a general rule, the accelerometer mass should not be greater than 1/10 the effective mass of the part or the structure that is mounted onto for dynamic testing. This is because the accelerometer should not load the tested part, since additional mass can significantly change the levels and frequency presence at measuring points and invalidate the results, (Eren, 1999). Higher sensitivity can also be achieved by amplifying the signal from a low sensitivity sensor, but because the noise is also amplified, the signal-to-noise ratio is not improved (Wilson, 1999b).

2.4 Applications: from modern to historical structures

2.4.1 Pioneering studies on modern structures and future challenges

Ivanovic et al. (2000) presented a comprehensive review of AVT from its early applications in USA.

The following are very few examples aimed at showing the development of application of this technique. In the early 1930's, the United States Coast and Geodetic Survey started measuring the fundamental periods of structures by AVT. In a period of about 4 years, AVT's were carried out on more than 340 structures in California and Montana. Some of these structures, like the Golden Gate Bridge, were being measured from time to time during construction. In Carder (1936a; 1936b; 1937), the found results and derived conclusions are discussed. Some 30 years later, Crawford and Ward (1964) and Ward and Crawford (1966) revived the interest in this method and showed that it can be used to determine the lowest frequencies and modes of vibration of full-scale structures. Around 1970, reports about testing of full-scale structures by the AVT began to appear regularly, with about 75% of all contributions devoted to the experiments of buildings, dams, chimneys and silos, and about 25% devoted to bridges testing. For instance, Trifunac (1970a, 1970b) used wind and micro-tremor induced vibrations to test a twenty-two and a thirty-nine story steel frame buildings. Two years later, the same author compared the results of FVT on the same two buildings with the results of AVT and found that the results of both tests were consistent and comparable (Trifunac, 1972). Throughout the 1970's and the 1980's, AVT and FVT were used to compare small amplitude with larger amplitude response and to find the pre- and post-earthquake apparent frequencies of full-scale structures (Mulhern and Maley, 1973). During the 1990's, AVT's continued to contribute to in-depth studies of the changes in structural properties (Mendoza et al., 1991) and towards further development of structural identification methods (Kadakal and Yuzugullu, 1996).

In the last decade up till now, the AVT is attracting more interest and hundreds of publications are available yearly on the subject. Despite the already long history of AVT, there are still several issues that need further research. The use of sophisticated parametric system identification algorithms in civil engineering structures is recent and still needs to become more mature throughout the performance of more practical applications. In addition, the developments of the acquisition hardware have permitted to obtain with little effort large databases that have to be processed in an efficient way. Therefore, there is the need to develop and test processing methodologies suitable to deal with large quantities of data (Magalhães, 2010).

2.4.2 Applications to historical construction

Applications of dynamic identification in the field of historical construction started decades after its use

for modern structures. Next, some of the pioneering studies are first referred and then more recent studies are discussed.

2.4.2.1 Early studies in the 90's

Chiostri et al. (1991 and 1992) tested a typical Florentine masonry building that was about to be demolished. They used FVT employing a vibrodome. The amplitude of excitation was raised until structural damage and partial collapse of some elements were produced. The first four experimental natural frequencies were determined and used to update a FE model of the structure. In the beginning of the 90's Aya Sofya in Istanbul was tested using AVT method (Durukal, 1992; Erdik et al., 1993). The tests were carried out using four uniaxial seismometers in 15 setups with measurement time about 1 to 2 minutes for each. The first 11 natural frequencies and mode shapes were identified using basic spectral analysis calculations. Tzenov and Dimova (1992) carried out AVT on a Bulgarian church from the 6th century that had suffered several structural problems along its history, in specific, developed alarming cracks in the columns. The AVT was caused by a car passing over an obstacle. They used 7 velocimeters and performed 7 setups. They concluded from the obtained mode shapes that (1) the connections between bearing walls were not sufficient; (2) the cracks had clear influence on the dynamic behavior; (3) the foundation characteristics were not identical under the different parts of the church.

Modena et al. (1997) carried out the dynamic identification of the roman amphitheatre (Arena) of Verona using FVT beside AVT. The overall structural behavior of the wing, and particularly its interaction with the main body of the amphitheatre was analyzed. Using FVT, it was possible to identify the first eight natural frequencies. For AVT, however, the authors found that electrical resonance of the acquisition system, which is not negligible for low intensity signals, made the frequency responses unreliable. Nevertheless, it was shown that at least qualitative comparison between theoretical and experimental responses were possible. They commented that although the FVT results were more accurate than the AVT, the application of FVT was rather difficult and costly because of the need of installing and removing of appropriate scaffolding to access the excitation points. Some years later, using only AVT the Arena wing was tested again by Lorenzoni et al. (2013). The average error in identified natural frequencies between the old and the new tests were found to be not more than 7,3%. It should be commented on this case study that the today available data acquisition technology can overcome the encountered problem in

the tests of 1997 because this new technology is characterized by ultra-low self-noise performance.

Some other examples of pioneering studies include masonry buildings (Capecchi et al., 1990; Angotti et al., 1992; Slastan and Foissner, 1995; Vestroni et al., 1996; Genovese and Vestroni, 1998; Sigmund and Herman, 1998); masonry bridges (Armstrong et al., 1995; Bensalem et al., 1995; Roca and Molins, 1997; Bensalem et al., 1998; Nasser, 2001); stone masonry pinnacles (Ellis, 1998) and stone masonry columns (Llorens et al., 2001; Araiza, 2003).

2.4.2.2 Recent studies

With more advances in sensors technology and dynamic identification techniques, vibration testing is attracting more attention as a powerful tool in the

investigation stage of historical structures and more research results are being published. Next, some of the recent studies are discussed.

The Gothic church of Fossanova in Italy was tested by AVT (De Matteis and Mazzolani, 2010; De Matteis et al., 2008). These tests were one of several investigation campaigns employed to study the structure and assess its seismic behavior. In total 25 points were selected for different setups, from which one point was selected as a reference for all setups, see Figure 5. The two global mode shapes in the longitudinal and transversal directions, in addition to, the first torsional mode were successfully identified. The damping ratios were found between 5.5% and 7.5% of critical damping.

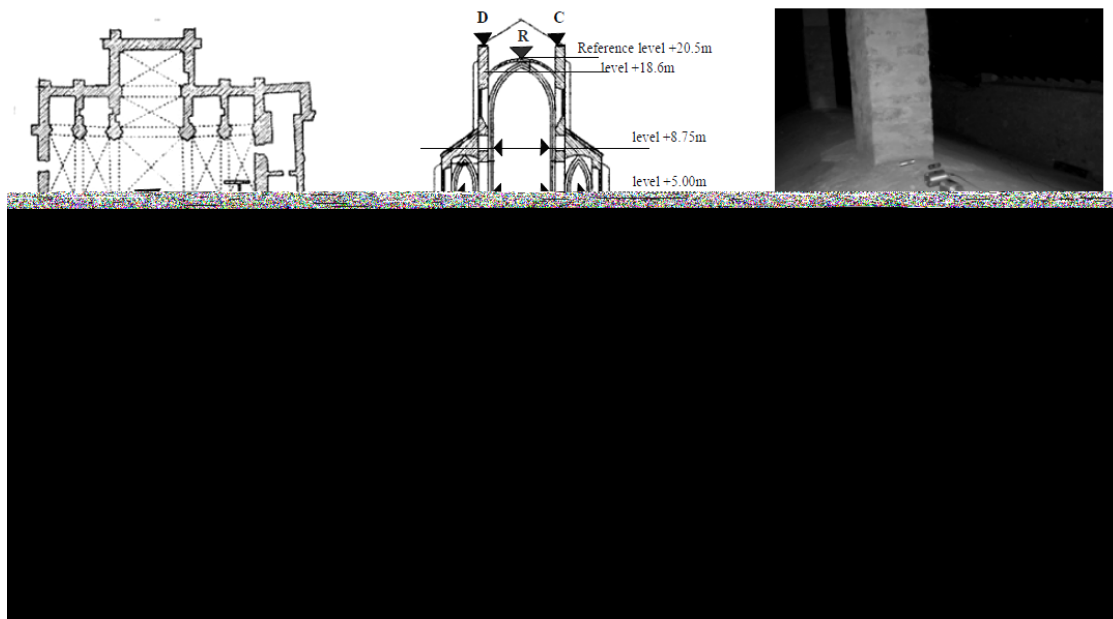

Figure 5. Setups of AVT of Fossanova church. Solid arrows show measurement points (De Matteis et al., 2007).

Atamturktur et al. (2009) discussed FVT's conducted on five Gothic churches in UK, USA and Italy. The general objective of the research was to give recommendations for FVT of vaults of typical bays of such structures. The preliminary FE models showed that the vaults mode shapes were composed of diagonal symmetry and bending. The diagonal symmetry modes constituted vertical movements of the crown, while the bending modes primarily constituted symmetric movements of diagonal and orthogonal axes, Figure 6(a). Therefore, a number of measurement points were selected at every one-third length on the main axes of the quadripartite vaults, Figure 6(b). The excitation points were selected where the highest responses were expected. The authors discussed a number of quality checks to be completed on the immediate findings of the FVT

which included: immediate repeatability check, linearity check and reciprocity check. The first was used to diagnose the effects of the ambient vibration on the FRF measurements. It was found that due to the massiveness of these structures, the different sources of ambient vibration were insignificant. The second and third checks aimed at discovering if the assumption of linear elasticity holds for the tested structures, it was found that these checks were satisfied as long as the excitation force is kept consistent throughout the test. For the tests setups, they commented that exciting the ribs is preferred to exciting the webbing because it reduced the difficulties in system identification due to the dominant local modes which occur when the webbing is excited.

Ramos et al. (2010) carried out the dynamic identification of the main nave of the Gothic Monastery of

Jerónimos in Lisbon. The Enhanced Frequency Domain Decomposition (EFDD) and the Stochastic Subspace Identification (SSI) methods were used and a comparison between both was made. No significant differences were found between the two methods as far as the natural frequencies were concerned.

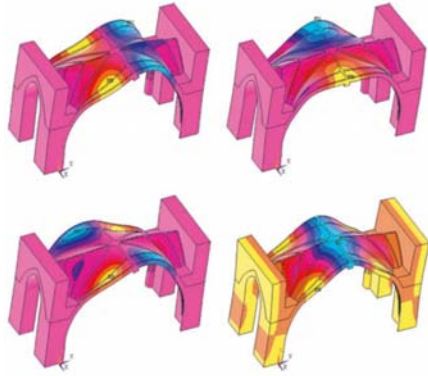

(a)

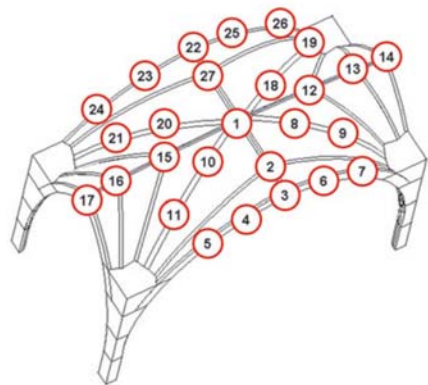

(b)

Figure 6. FVT of Gothic vaults: (a) preliminary FE mode shapes; (b) measurement and excitation points (1,3,12,18) (Atamturktur et al., 2009).

For the damping coefficients, differences up to 140% were observed due to the noise in the signals and the low excitation levels. The Modal Assurance Criteria (MAC) values were higher than 0,95 only for the first two mode shapes as a consequence of the difficulty in exciting this heavy structure. However, the authors commented that this modal identification was accepted because of the structural complexity of this structure. Also, the usage of two identification methods helped them in the validation and discussion of results.

The modal parameters of the historical large scale Reggio Emilia cathedral were identified using the AVT (Casarin and Modena, 2008; Casarin and Modena, 2006; Casarin, 2006). The identified mode shapes and natural frequencies were used then in updating a FE model and carrying out seismic assessment analysis. The measurements were taken at the structure's elements that were considered most

characteristic from a dynamic point of view. Those were the dome, the facade dome lantern, and the upper part of the main nave. The acquisition time was about 11 minutes at a sample rate of 100 Hz which was appropriate because the significant structural frequencies were between 0–10 Hz, i.e. the selected sampling time was about 10 times the highest frequency to be measured. The Frequency Domain Decomposition (FDD) method was used to extract the modal parameters. It was found that although several peaks appeared in the Power Spectral Density (PSD), only few structural modes were satisfactorily detectable with coherence in the range of 0.8–0.9.

The famous Colosseum of Rome was tested by Pau and Vestroni (2008). The aim was to investigate the traffic effect on the safety of the structure and also to update its preliminary FE model. Based on initial FE modal analysis, the authors decided about the used instruments, their location and the parameters for data acquisition. Two setups of AVT were performed. FVT was carried out on the columns using an instrumented hammer. The first 6 natural frequencies of the structure were satisfactorily identified, whereas, only the first two mode shapes were satisfactory estimated.

An interesting research aimed at providing a methodology for choosing the optimum locations of sensors in dynamic identification tests of Gothic cathedrals with the application to St. John the Divine cathedral in Washington was presented by Prabhu and Atamturktur (2013) and Prabhu (2011). Optimal sensor locations were determined by using a validated FE model of the cathedral's nave and a modified version of the Effective Independence Method (EIM) developed by Kammer (1991). In this methodology the following steps were applied: 1) a number of candidate locations were selected based on practical considerations like the easy access to these locations, Figure 7 (a); 2) the global mode shapes that desired to be identified experimentally were selected from a modal analysis carried out using the validated FE model of the cathedral. The model was validated against the modal parameters deduced from FVT of one vault of the main nave and also by checking its capability to reproduce some visible cracks in the cathedral that are believed to be resulted from gravity loading only; 3) the candidate locations are reduced to an optimum number of sensor locations using the EIM after being modified by introducing a distance-based criterion so that the final optimal set of sensors is not clustered, Figure 7 (b). The authors believe that their research presents a number of optimum regions suitable for sensor placement for similar Gothic cathedrals, and the use of these recommended locations is anticipated to reduce the neces-

sary resources and to expedite the modal testing of similar structures.

In addition to the previously discussed case studies of dynamic testing of historic structures, some additional cases can be mentioned. These include the AVT carried on a historical basilica in Rome (Pau and Vestroni, 2013); a fortress in L'Aquila damaged by Abruzzo 2009 earthquake (Lorenzoni, 2013); a church in Portugal (Alaboz, 2009); a large cathedral in Spain (Caselles et al., 2012; Elyamani et al., 2017a and 2017b); and many historic buildings in Cyprus including a Gothic cathedral, a Byzantine church, ruins of a church and some schools (Votsis et al., 2013; Votsis et al., 2012; Lourenço et al., 2012; Chrysostomou et al., 2013).

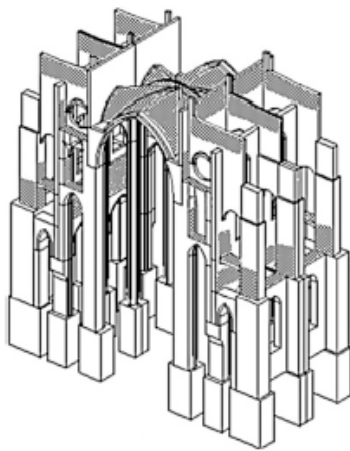

(a)

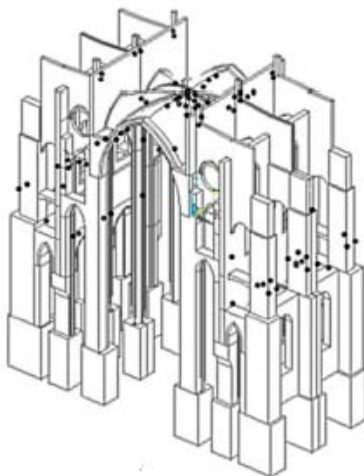

(b)

Figure 7. Choosing optimum sensor locations in Gothic cathedrals: (a) candidate locations are shaded; and (b) optimum locations as dots (Prabhu and Atamturktur, 2013).

Finally, it is worthy to comment that the dynamic tests (also the identification process and the numerical model updating) are easier to carry out on some types of masonry historic structures. Those are the

structures characterized by one predominant dimension, as for instance, arch bridges in which the longitudinal dimension is predominant and tall structures like bell towers in which the vertical direction is predominant. The dynamic behavior of these structures is simple compared to other types of structures like churches and large complex Gothic cathedrals. For case studies of dynamic identification of historical arch bridges, refer to Sena-Cruz et al. (2013); Pau and Vestroni (2011). For tall structures, see Corbi et al., (2013); Bayraktar et al. (2011); Aoki et al., (2008) ; Gentile and Saisi (2013) and Ivorra et al. (2011).

3. DYNAMIC MONITORING OF HISTORICAL CONSTRUCTION

3.1 Motivations

Similar to the dynamic identification, dynamic monitoring is carried out to achieve the following two objectives: to obtain information on the global dynamic behavior of a historical structure and to validate and update a historical structure's numerical model.

In addition, dynamic monitoring may also aim at achieving the following purposes (D10.4-NIKER, 2012; D9.4-NIKER, 2012): 1) to study the evolution of modal parameters in time, thus evaluating quantitatively the progression of the damage pattern (structural health monitoring), 2) to study the influence of environmental climatic effects (temperature, humidity, etc.) on the dynamic parameters, 3) to capture the dynamic response in the occasion of possible seismic events. The measured accelerations in this case are expected to be higher than those measured in AVT by several orders of magnitude. Thus, it helps to better characterizing the structure's modal parameters that may be unattainable from AVT like the damping ratios and the higher modes of vibration which are difficult to obtain under ambient vibrations only, 4) to verify the effectiveness of any possible intervention. Before the execution, the dynamic monitoring can work as an early warning system to detect the need for any urgent intervention. During the execution, it can provide warning procedures contributing to the safety of the personnel involved. After the execution, by comparing the dynamic parameters before and after the intervention, it is possible to evaluate its effectiveness. In addition, it can be used to perform verification and long term control within a long-term maintenance program. This purpose is shown schematically in Figure 8. In the figure, the diagnosis reveals that the structure doesn't have the required seismic capacity. Therefore, an intervention is undertaken to increase the seismic capacity. The capacity may include some distinct increments if the intervention is applied incrementally. An evaluation

phase follows to verify the efficiency of the intervention. The last and longest phase is the maintenance one during which the structure is monitored to verify the maintenance of the expected seismic capacity. Possible correction actions may be required if it de-

creases below the tolerable limit. At the end of the maintenance period, a new seismic assessment, with a possible new intervention, may be necessary.

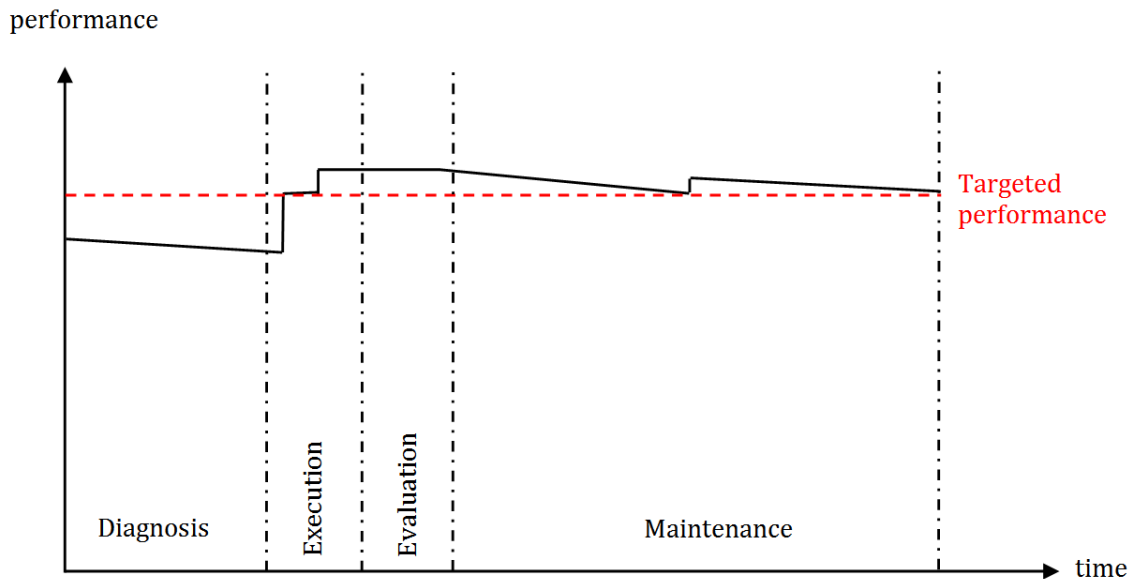

Figure 8. Different monitoring phases across the study of a cultural heritage building, intervention and maintenance (D9.4-NIKER, 2012).

3.2 Types of dynamic monitoring systems

According to the types of instruments involved, the dynamic monitoring systems can be classified in two groups: conventional wired based systems and wireless based systems, Figure 9. The first system is composed by measurement sensors, Data Acquisition (DAQ) system and in some cases remote connection system. These systems are still widely in use, in principal, for three reasons: 1) there are a lot of commercial solutions that need just to be placed in the structure; 2) there are several types of measurement sensors and DAQ systems with high sensitivity and resolution; and 3) there is well known commercial software available for the dynamic identification of modal parameters. However, they possess two important drawbacks: high costs of these equipments due to the need of high sensitive sensors for measuring the low amplitude vibrations, and architectural limitations for the deployment of the equipments. As a result to the previously mentioned limitations of wired systems, there is an increasing interest for wireless monitoring systems as a low cost, easy to install alternative. A typical wireless system is composed by measurement units, base station and in some cases remote connection system. The measurement units are formed by MEMS (Micro Electro-Mechanical Systems) as measurement sen-

sors, and autonomous DAQ platforms that collect the data and send them wirelessly to a base station. The base station is formed by a DAQ platform coupled with an interface board in charge on data transferring to a local computer. The remote connection is in charge on data transferring from the local computer to a central "brain" station. (Aguilar, 2010)

According to the activation regime of the recording devices, three different systems can be distinguished. The first is the dynamic monitoring system with threshold. In this system, the recording devices are automatically activated when the amplitude caused by the excitation (for instance, an earthquake) surpasses some predefined threshold. Thus, only the strong motion experience during meaningful episodes is captured. The second is the periodical dynamic monitoring in which the recording devices works constantly, capturing a sufficiently dense input, during some given intervals activated in a periodic way according to a predefined program. The third is the continuous dynamic monitoring. This system records continuously the vibrations experienced by the historical structure. In the post processing of saved data, meaningful episodes involving earthquakes, micro-tremors or wind can be extracted (D10.4-NIKER, 2012).

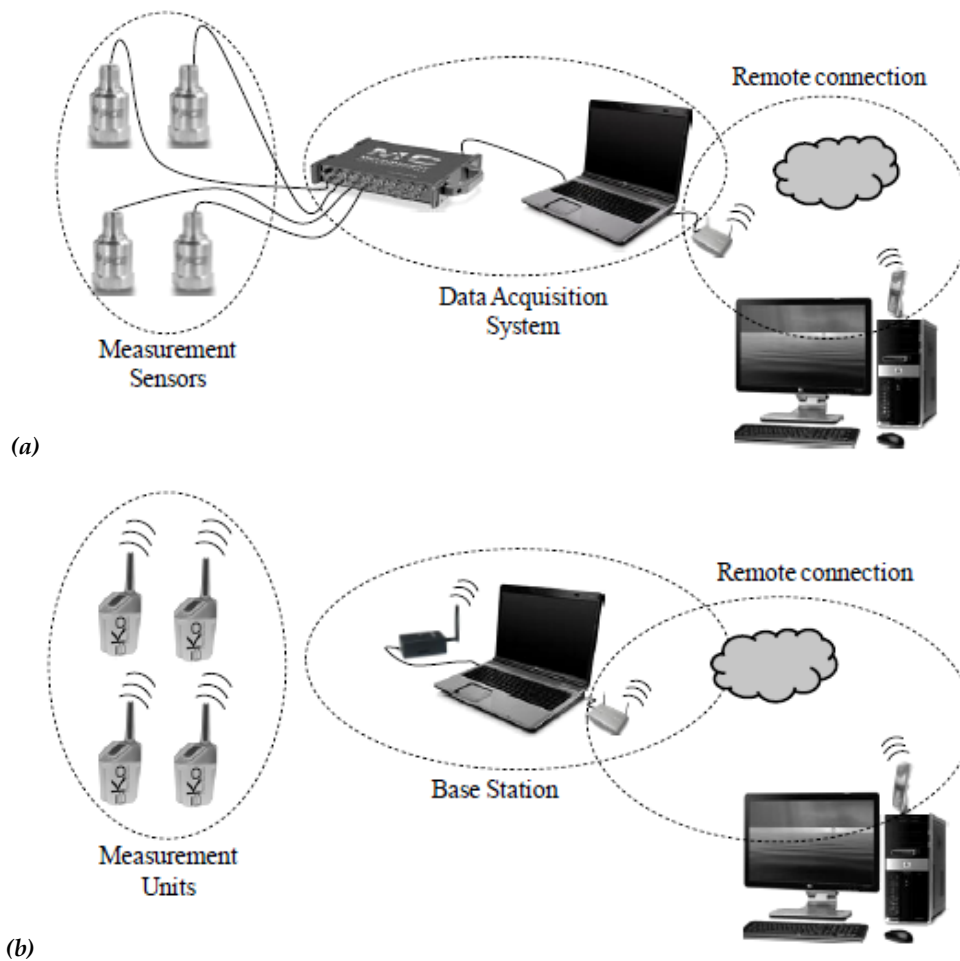

Figure 9. Types of dynamic monitoring systems: (a) conventional wired based systems; and (b) wireless based systems (Aguilar, 2010).

3.3 Applications of dynamic monitoring to cultural heritage buildings

A pioneering study of the dynamic monitoring of large scale historical construction was the one carried out by Erdik et al. (1993). The authors instrumented the Aya Sofya in Istanbul with 9 triaxial strong motion accelerometers. The system was triggered with a previously defined threshold. The system captured a seismic event of $M_b=4.8$ and 105 km epicenter far from the structure. Although the event had a low-amplitude, about 12% decrease was observed in the frequencies of the first two modes during the event when compared to those identified under AVT levels.

A dynamic monitoring system was installed in the Roman Arena of Verona by the end of 2011 and is still in operation (Lorenzoni et al., 2013). It is a conventional wired system including 16 uniaxial accelerometers and a remote connection. For the dynamic measurements, two strategies are being used. The first is periodical each 24 hours for a time of about 22 minutes at a sampling rate of 100 Hz to allow daily dynamic identification with the change of the envi-

ronmental conditions. The second is with threshold for duration of about 4 minutes at a sampling rate of 100 Hz to capture any possible seismic events. During the period from December 5, 2011 to May 31, 2013, the system was used to identify the modal parameters of the first seven modes of the Arena wing using the periodical measurements. The values of the coefficient of variation of the natural frequencies showed that the environmental conditions had a clear influence on these modal parameters, with a variation over the frequencies from about 2 to 6% were found. The structural response was also registered during two seismic events of magnitudes of 4,2 and 5,8 with epicenters at 11 (near-field) and 70 (far-field) Km from the city of Verona, respectively. The data collected during the near-field earthquake were used to carry out a dynamic identification before, during and after the event to evaluate possible changes in modal parameters. A significant decrease (from 16% to 30%) of all natural frequencies was observed during the earthquake. Modal damping ratios showed significant increase during the earthquake meaning that the dissipation mechanisms of the construction had been fully activated. After the earth-

quake, both modal parameters showed slight permanent decrement, however, no damage was observed in the structure after a careful inspection followed the earthquake.

Russo (2013a) discussed the results of a 2-year dynamic monitoring system of a historical church damaged by the earthquake of L'Aquila (Italy) in 2009. After the earthquake, the remaining parts of the church were kept in place using emergency safety measures including the usage of steel ties for confinement. A wired system with threshold consisting of 20 piezoelectric accelerometers was used. The accelerometers were distributed all over the church so that each group of them could control the dynamic behavior of a macro element of the structure. The objective was to study the dynamic behavior of each of the macro elements alone and also the full behavior of the strengthened construction under the effect of the after-shock events. Six events were captured and analyzed. Two of them occurred before the full strengthening measures were completed. The author compared between the full church's dynamic response before and after the complete execution of the safety measures. It was noticed that the dynamic behavior clearly improved because of the strengthening measures, which caused an increase of the natural frequencies and damping ratios.

A dynamic monitoring system was installed in a masonry tower after its repair intervention with the objective to evaluate the environmental effects (temperature and relative air humidity) on the dynamic behavior and to detect any possible damage (Ramos et al., 2010). A wired system with three piezoelectric accelerometers was used. The system recorded periodically ten minutes of ambient vibrations each one hour with no threshold specified. It was found that the environmental effects significantly changed the dynamic response of the structure. In specific, the water absorption of the walls in the beginning of the raining seasons changed the frequencies about 4%.

The seismic response of the Mexico City Cathedral was investigated by a dynamic monitoring system during several earthquakes occurred between 1997 and 2003 by Meli et al. (2001) and Rivera et al. (2008). The network was composed 1 accelerometer located at ground level 10m outside the cathedral's foundation, 3 accelerometers placed at the foundation level and 4 accelerometers were located on the roof. The system was a wired one of a triggered-based type. Around 20 events were captured that had epicenters at least 100 km away from the building. For the comparison between the measurements at the roof and at the foundation level, it was noticed that the maximum recorded ground acceleration was about 0,015g whereas the maximum acceleration recorded on the cathedral roof, for the same event, was about

0,018g. This indicated that the cathedral moved like a rigid body with a very small amplification. Important findings were obtained for the fundamental periods and the damping ratios of the cathedral in the two horizontal directions (E-W and N-S). First, the fundamental period increased in the zone of maximum intensity of an earthquake and decreased later on, returning at the end of the record close to its initial value.

This indicated a significant nonlinear behavior during the event which could be related to the existing cracking in the masonry and that no additional damage has been produced by the studied event. Second, the obtained damping coefficients varied clearly with the magnitude of the earthquake. The damping ratios increased from 4 to 6% for the transverse direction (E-W) and from 7 to 12% for the longitudinal direction (N-S). In average, damping was 50% greater for a magnitude 7.6 than for a magnitude 5.9 earthquake. This again was attributed to early nonlinear behavior due to cracking. Two of the accelerograms were then removed from the cathedral and placed on one of the bell towers to study its local seismic response. It was observed that the maximum recorded acceleration at the tower top level was 7.5 times greater than that at the basement level. This suggested that the towers vibrated with the façade as a structure almost independent from the rest of the building. This assumption was consistent with the presence of a wide transverse crack crossing the whole span of the nave in its first bay.

The following is a number of studies on dynamic monitoring of cultural heritage that are briefly discussed. Cabboi (2014) proposed a methodology for automatic processing of permanent dynamic monitoring data and applied it to a historic iron arch bridge and a historic masonry tower. The automatic procedure is based on the Covariance-Driven Stochastic Subspace Identification method (see section 4.2.3 about this identification technique). In his methodology, he gave some recommendations on the selection of some input parameters of this method. For the masonry tower, he observed that the dynamic behavior exhibited a high variance in time. All the identified frequencies tended to increase with the temperature increase. Other publications related to this research can be consulted at Cabboi et al., 2014; Cabboi et al., 2013a; Cabboi et al., 2013b).

Ramos et al. (2013) introduced an algorithm for automatic processing of dynamic monitoring measurements for the identification of modal parameters. The algorithm is based on the Data-Driven Stochastic Subspace Identification method (see section 4.2.3 about this identification technique) and was applied to a Portuguese church. One of the important findings was the clear scatter in the identified damping

ratios for all identified modes during the whole monitoring period. Lorenzoni (2013) proposed an algorithm for automatic dynamic monitoring and applied it to four case studies in Italy. His algorithm is based on polyreference Least Square Complex Frequency domain (see section 4.2.4 about this identification technique). He found (similar to Ramos et al., 2013) that the identified damping ratios manifested a high scatter.

An example of using the dynamic monitoring as a tool for controlling intervention can be found at Lorenzoni (2013) and Gaudini et al. (2008) who presented the results of a dynamic monitoring system installed in the stone tomb of Cansignorio della Scala in Verona. One of the important results in this case study is the effect of the removal of scaffolding that was installed temporary for carrying out some interventions. By processing the monitoring data, it was clearly noticed a decrease in the identified natural frequencies after scaffolding removal. The captured seismic responses of two instrumented mosques in Turkey were presented by Erdik and Durukal (1996).

Contrary to the large available number of publications on dynamic identification of historic structures, only few publications exist for dynamic monitoring studies. A few years ago, Rivera et al. (2008) commented that “only a handful of historic buildings have been instrumented worldwide”. This fact can be confirmed by reviewing the number of publications on the subject in the series of the conferences on Structural Analysis of Historical Constructions (SAHC). In the first 8 editions of this conference, less than 1% of the published papers were dedicated to the dynamic monitoring. The situation is similar also regarding the number of publication in international journals.

4. MODAL PARAMETERS IDENTIFICATION

The acquired signals via the previously discussed dynamic investigation activities are processed by identification techniques in order to identify the modal parameters of a historical building. In any of these techniques, the signal processing is an essential step. Therefore, this part first gives some important concepts in signal processing like sampling, spectral analysis, Fast Fourier Transform (FFT), aliasing, etc. Following, a number of modal parameters identification techniques widely used are presented.

4.1 Concepts in signal processing

4.1.1 Signal, system and signal processing

A signal is a description of how one parameter varies with another parameter, for instance, voltage changing over time in an electronic circuit (Smith,

2002). Mathematically, a signal is a real (or complex) valued function of one or more real variable(s) (Sharma, 2014). A system is any process that produces an output signal in response to an input signal. Continuous systems input and output continuous signals, such as in analog electronics. Discrete systems input and output discrete signals, such as computer programs that manipulate the values stored in arrays (Smith, 2002).

Signal processing means to operate in some fashion on a signal to extract some useful information, e.g. manipulate or combine various signals, extract information, or otherwise process the signal (Sharma, 2014; Kulkarni, 2014). Signal processing can be implemented in two different ways: analog (or continuous time method) and digital (or discrete time method). The analog approach uses analog circuit elements such as resistors and transistors, and was dominant for many years. The analog signal processing is based on the ability of the analog system to solve differential equations that describe a physical system. Nowadays with the advent of digital computers and microprocessors, the digital signal processing has become dominant. The digital signal processing relies on numerical calculations (Sharma, 2014).

4.1.2 Sampling

Sampling is the process of picking one value of a signal to represent the signal for some interval of time. The Nyquist sampling theorem provides a quantitative answer to the question of how to choose the sampling time interval which must be small enough so that signal variations that occur between samples are not lost. It states that “if a signal only contains frequencies less than cut off frequency f_c all the information in the signal can be captured by sampling it at a minimum frequency of $2f_c$ ”. Therefore, two conditions must be met. First, the signal $x(t)$ must be band-limited, i.e., its frequency spectrum must be limited to contain frequencies up to some maximum frequency f_{max} and no frequencies beyond that. Second, the sampling rate f_s which represents the density of samples per unit time and is measured in units of samples/sec or Hertz (Hz) must be chosen to be at least twice the maximum frequency f_{max} , that is $f_s \geq 2f_{max}$. The minimum allowed sampling rate is called the Nyquist rate. For the second condition, nevertheless, common practice dictates that while working in the frequency domain, the sampling rate must be set more than twice and preferably between five and ten times the signal’s highest frequency component (Loewenstein, 1999; MC, 2005; Antonelli et al., 1999; Orfanidis, 1996).

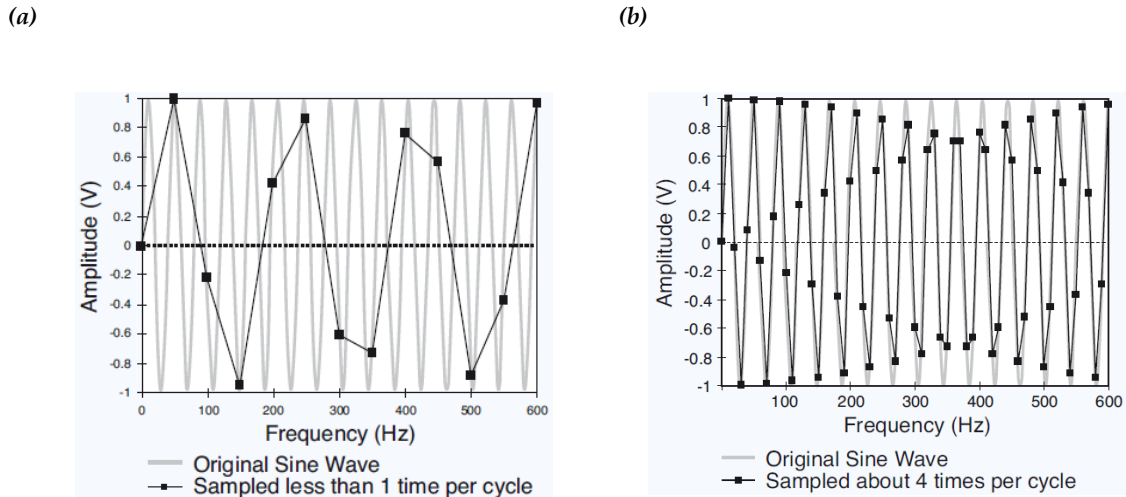

Figure 10. Aliasing: (a) inadequate Nyquist sampling rate; and (b) acceptable Nyquist sampling rate (MC, 2005).

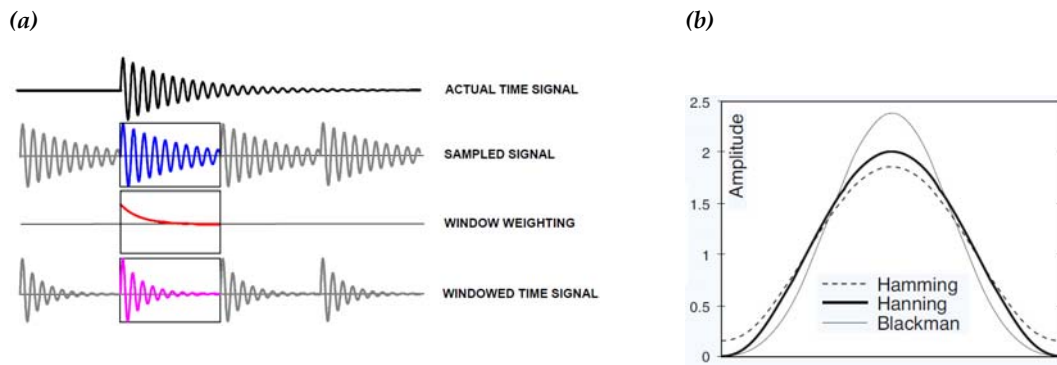

Figure 11. (a) Minimizing the leakage effect using the exponentially decaying window (Avitabile, 2001); and (b) Hamming, Hanning, and Blackman window functions (adapted from MC, 2005).

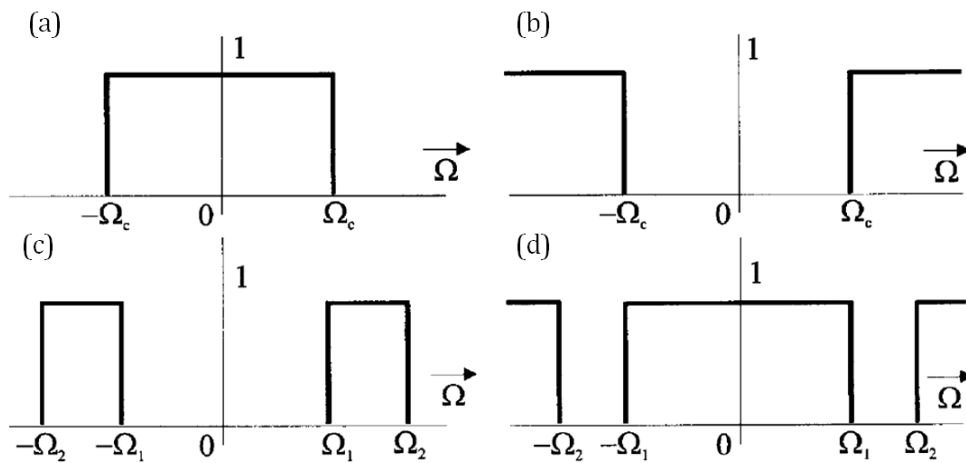

Figure 12. Filters types: (a) low-pass; (b) high-pass; (c) band-pass; and (d) stop-band. Note that the magnitude function of an ideal filter is 1 in the pass-band and 0 in the stop-band (adapted from Jamal and Steer, 1999).

4.1.3 Noise and white noise

Desired signals are subject to various types of degradation in many applications. This degradation can arise from a variety of sources such as limitations of the response transducers, random and/or un-modeled fluctuations of underlying physical processes, or environmental conditions during sensing, transmission, reception, or storage of the data. Thus, the term noise is typically used to describe a wide range of degradation (Kulkarni, 2014).

White noise is a basic concept underlying the modeling of random disturbances, such as sensor noise and environmental disturbances. In contrast to continuous time, white noise is straightforward to characterize in discrete time. The noise signal said to be white if (Reist, 2013) (1) it has zero mean and unit variance, (2) it is independent from sample to sample, i.e. not correlated in time.

4.1.4 Signal conditioning

Commonly, signals measured by a sensor do not have acceptable characteristics for display, recording, transmission, or further processing. For instance, they may lack the amplitude, power, level, or bandwidth required. Also, they may have superimposed interference that may mask the required information. Signal conditioning aims at adapting sensor's signals to the requirement of the receiver they are connected - whether a circuit or equipment (Pallas-Areny, 1999). In the following, a number of common signal conditioning functions are briefly discussed, mainly stressing the concept behind.

4.1.5 Aliasing

Aliasing occurs when input signals are sampled at less than the Nyquist rate. As a result, ambiguous signals that are much lower in frequency than the signal being sampled can appear in the time domain. For instance, Figure 10(a) shows a 1 kHz sine wave sampled at 800 Hz. The reconstructed frequency of the sampled wave is much too low and is not a true reproduction of the original frequency. Alternatively, Figure 10(b) shows the same signal sampled at more than twice the input frequency or 5 kHz. Consequently, the sampled wave now appears closer to the original one. To prevent aliases, a low-pass, anti-aliasing filter is used. Although the filter eliminates the aliases, it also prevents any other signals from passing if their frequencies are above the stop band of the filter. Therefore, the DAQ system should be selected so that the sampling frequency per channel is more than twice (at least) the highest frequency intended to be measured (MC, 2005).

4.1.6 Leakage and windows

The leakage error occurs when transforming a signal from the time domain to the frequency domain using FFT. The FFT can produce a proper representation of the data in the frequency domain if the sampled data consist of either a complete representation of the measured data for all time or alternatively contain a periodic repetition of the measured data. When any of these are not satisfied, then leakage will occur causing a serious distortion of the data in the frequency domain. To minimize this effect, weighting functions called windows are applied to the measured data to force it to better satisfy the periodicity requirements of the FFT (MC, 2005). An example of these functions, the exponentially decaying window, is shown in Figure 11(a). Some other common window functions are Hanning, Hamming, Blackman, Figure 11(b).

4.1.7 Filters

Distortions in the data that reside in a frequency band that can be separated from the frequency band of interest can be removed by filtering the data. Filters are commonly classified according to the filter function they perform, Figure 12. In this figure, it is shown the basic filtering functions: low-pass, high-pass, band-pass, and band-stop. A low-pass filter passes frequencies from zero to its cutoff frequency Ω_c and stops all frequencies higher than the cutoff frequencies. On the contrary, a high-pass filter stops all frequencies below its cutoff frequency and passes all frequencies above it. A band-pass filter passes frequencies from Ω_1 to Ω_2 and stops all other frequencies. Oppositely, a band-stop filter stops frequencies from Ω_1 to Ω_2 and passes all other frequencies (Jamal and Steer, 1999; Verhaegen and Verdult, 2007).

4.1.8 Decimation

When the sampling frequency is too high with respect to the bandwidth of interest of the tested structure, one may resample the data by selecting every j th sample from the original data sequences. If the original sampling frequency was f_s , the so-called down-sampled or decimated data sequence is sampled with a frequency of f_s / j . This is carried out because a too high sampling frequency results in high-frequency disturbance in the data above the frequency band of interest. Before decimation, a digital anti-aliasing filter with a cut-off frequency of $f_s / 2j$ must be applied to prevent aliasing (Verhaegen and Verdult, 2007).

4.2 Modal parameters identification methods

The methods developed for the extraction of modal parameters for FVT are based on employing the FRF's derived in frequency domain or on the equivalent Impulse Response Functions (IRF's) in time domain (Hu, 2012). These methods are generally classified as frequency domain or time domain approaches. Some of the frequency domain methods are the Peak-Picking (PP) method, the Complex Mode Indicator Function (CMIF) method and the polyreference Least Squares Complex Frequency (pLSCF) method. Some of the time domain methods are the Least-Squares Complex Exponential (LSCE) method, the Poly Reference Complex Exponential (PRCE) method, the Multiple Reference Ibrahim Time Domain (MRITD) method and the Eigen-system Realization Algorithm (ERA) method.

For AVT, the proposing of Natural Excitation Technique (NExT) by James et al. (1992) was a milestone step that allowed the adaptation of FVT identification methods to be used in AVT. The idea behind the NExT technique is that Correlation Functions (COR's) between the responses can be expressed as a sum of decaying sinusoids. Each decaying sinusoid has a damped natural frequency and damping ratio that is identical to the one of the corresponding structural mode. Consequently, COR's can be employed as IRF's to estimate modal parameters (Hu, 2012). For instance, in the frequency domain, the FDD and the PolyMAX methods were developed by Brincker et al. (2000a) and Peeters et al. (2004), respectively, by replacing the FRF's matrix with the output spectral matrix assuming that the input is white noise. Similarly, in the time domain, by replacing IRF's with COR's, the Covariance driven Stochastic Subspace Identification (SSI-COV) method was developed by Peeters (2000).

For more about classification of dynamic identification techniques, the interested reader can refer to Cunha et al. (2013); Hu et al. (2010); Masjedian and Keshmiri (2009), De Stefano and Ceravolo (2007); Cunha et al. (2006); Zhang et al. (2005); Ren and Zong (2004); Peeters and De Roeck (2001); Maia and Silva (2001); Maia and Silva (1997). In the following, some of the widely used methods are discussed to show their theoretical background, advantages and limitations.

4.2.1 Peak picking (PP)

The Peak Picking (PP) method is the simplest known method for identifying the modal parameters of structures tested by AVT. It is a frequency domain based identification technique and is also called Basic Frequency Domain (BFD). Frequency domain algorithms are most popular mainly due to their

simplicity and processing speed. It is based on simple signal processing using the Discrete Fourier Transforms (DFT). It depends on the fact that well separated modes can be estimated directly from the PSD matrix at the peak as proposed by Bendat and Piersol (1993). There is other implementations of that make use of the coherence between channels as proposed by Felber (1993). In the context of FVT, the PP is based on the fact that the FRF reaches extreme values around the natural frequencies; therefore, the frequency at which this extreme occurs is a good estimate for the frequency of the structure. In the context of AVT, the FRF is only replaced by the auto spectra of the ambient outputs. In such a way the natural frequencies are simply determined from the observation of the peaks on the graphs of the averaged normalized power spectral densities (ANPSDs). The ANPSDs are basically obtained by converting the measured accelerations to the frequency domain by DFT (Brincker et al., 2001a; Brincker et al., 2000a; Brincker et al., 2000b; Andersen et al., 1999).

Even though the input excitation is not measured in AVT, this problem has often been solved by adopting a derived modal parameter identification technique where the reference sensor signal is used as an input and the FRF's and coherence functions are calculated for each measurement point with respect to this reference sensor. The coherence function calculated for two simultaneously recorded output signals has values close to one at the resonance frequencies because of the high signal-to-noise ratio at these frequencies. Accordingly, inspecting the coherence function helps in selecting the natural frequencies of the structure. This method also yields the operational shapes that are not the mode shapes, but almost always correspond to them. The components of the mode shapes are determined by the values of the transfer functions at the natural frequencies. In the context of AVT, transfer function means the ratio of response measured by a roving sensor over response measured by a reference sensor. So, every transfer function yields a mode shape component relative to the reference sensor. Here it is assumed that the dynamic response at resonance is only dominated by one mode. The validity of this assumption increases as the modes are better separated and as the damping in the structure is lower (Ren and Zong, 2004).

The PP has some advantages, it is fast, user friendly, simpler to use and gives the user a feeling of the data he is dealing with. Because the user works directly with the spectral density functions, this helps him in figuring out what is structural just by looking at the spectral density functions. This strengthens the user understanding of the physics, hence pro-

vides a valuable tool for a meaningful identification. Also, the PP gives a clear indication of harmonic components in the response signals. The PP technique has some drawbacks: picking the peaks is always a subjective task; operational deflection shapes are obtained instead of mode shapes; only real modes or proportionally damped structures can be deduced by the method; and damping estimates are unreliable. In spite of these drawbacks many civil engineering cases exist where the PP technique is successfully applied (Ren and Zong, 2004; Brincker et al., 2000a; Peeters and De Roeck, 1999).

4.2.2 Frequency domain decomposition (FDD)

The Frequency Domain Decomposition (FDD) method was firstly presented by Brincker et al. (2000a, 2000b; 2001a). Nevertheless, the concepts behind the method had already been used in the analysis of structures subjected to AV by Prevosto (1982) and Correa and Costa (1992), and on the identification of modal parameters from FRF (Shih et al., 1988b) (Magalhães and Cunha, 2011). In the FDD, it is shown that taking the Singular Value Decomposition (SVD) of the spectral matrix, the spectral matrix is decomposed into a set of auto spectral density functions, each corresponding to a single degree of freedom (SDOF) system (Brincker et al., 2000a; 2000b; 2001a).

The FDD aims to be a simple and user-friendly technique allowing at the same time the accurate separation of closely spaced modes which is not achievable by the PP technique (Magalhães and Cunha, 2011). The FDD results are exact provided that the excitation is white noise, the structure is lightly damped and the mode shapes of closely spaced modes are geometrically orthogonal. If these assumptions are not satisfied, the decomposition into SDOF systems is approximate, but still the results are significantly more accurate than the results of the PP method (Brincker et al., 2000a; 2000b; 2001a). Like the PP technique, the FDD cannot estimate the damping ratios; therefore, a new method was developed by Brincker et al. (2001b), called the Enhanced FDD or EFDD, to overcome this drawback.

4.2.3 Stochastic subspace identification methods

Stochastic Subspace Identification (SSI) modal estimation algorithms have been around for about two decades by now (Brincker and Andersen, 2006). The real break-through of the SSI algorithms was introduced by Van Overschee and De Moor (1996). In this book, it was showed that the SSI algorithms were a strong and efficient tool for natural input modal analysis. Because of the immediate acceptance of the

effectiveness of the algorithms the mathematical framework described in the book where accepted as a de facto standard for SSI algorithms (Brincker and Andersen, 2006).

The SSI methods perform the identification of modal parameters using a stochastic state-space model. This model in its discrete form and assuming the excitation as a white noise is represented by:

$$\begin{aligned} \mathbf{x}_{k+1} &= \mathbf{A} \mathbf{x}_k + \mathbf{w}_k \\ \mathbf{y}_k &= \mathbf{C} \mathbf{x}_k + \mathbf{v}_k \end{aligned} \quad \text{Equation 1}$$

Where \mathbf{x}_k is the discrete-time state vector at time instant k , \mathbf{y}_k is the vector with the sampled outputs, \mathbf{A} is the discrete state matrix, \mathbf{C} is the discrete output matrix and \mathbf{w}_k , \mathbf{v}_k are vectors that represent the noise due to disturbances and modeling inaccuracies and the measurement noise due to sensor inaccuracy. If the identification of matrices \mathbf{A} and \mathbf{C} is performed from the measured time series, the method is called Data-driven Stochastic Subspace Identification (SSI-DATA), and if performed from the correlations of the time series, it is called Covariance-driven Stochastic Subspace Identification (SSI-COV). Both methods are based on the properties of stochastic systems (Van Overschee and Moor, 1996) and involve singular value decomposition and the resolution of a least-squares equation (Peeters, 2000). The quality of the results obtained by both methods is similar. But, the SSI-COV method is faster and requires less memory, because the time series are compressed in covariance matrices. After the identification of the state-space model, modal parameters are extracted from matrices \mathbf{A} and \mathbf{C} (Magalhães et al., 2010).

Peeters and De Roeck (1999) introduced a modified version of classical SSI-COV called SSI-COV/ref. In this method the modification consisted of reformulating the algorithm so that it only needed the covariances between the outputs and a limited set of reference outputs instead of the covariances between all outputs. In the same publication they proposed also a modified version of SSI-DATA called SSI-DATA/ref. In this new method the idea was to take instead of all past outputs only the past reference outputs when projecting the future output into the past outputs.

The identification of the state-space model requires the definition of the model order. Nevertheless, it is not possible to predict the model order that better fits the experimental data and realistically characterizes the dynamic behavior of the tested structure. Therefore, the estimation of the modal parameters is carried out using models with an order within an interval defined in a conservative way.

The identified modal parameters are then represented in a stabilization diagram that allows the distinction of parameters that are stable for models of increasing orders (points over the same vertical alignment), and these are the ones with structural significance (Figure 13). The others are just associated with numerical modes, which are important to model the

noise that exists always in measured data (Figure 13). In other words, the frequencies indicating a structural mode appear in a stable vertical alignment of identified poles; instead, the frequencies indicating spurious poles appear randomly scattered in the diagram (Magalhães et al., 2010; Cabboi, 2014).

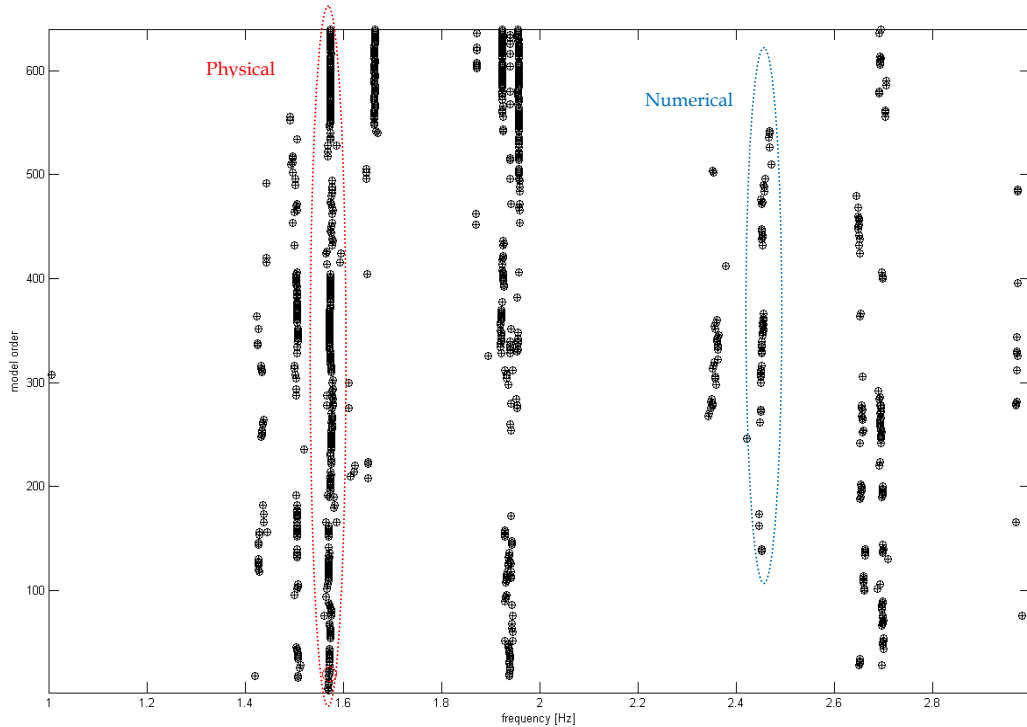

Figure 13. Example of a stabilization diagram showing the difference between physical and numerical modes (Elyamani, 2015).

The SSI methods are time domain based techniques that directly works with time data, without the need to convert them to correlations or spectra. However, and common to all system identification methods for AVT, it is not possible to obtain an absolute scaling of the identified mode shapes (e.g. mass normalization) because the input remains unknown (Ren and Zong, 2004). Some proposals to overcome these limitations can be found at Brincker and Andersen (2003b); Bernal (2003); Bernal and Gunes (2002) and Parloo et al. (2002). In specific for SSI/ref methods, the prediction errors are higher for channels that do not belong to the reference channels because these channels are partially omitted in the identification process. However, there is a clear reduction in the dimensions of the problem and the computation time (Peeters and De Roeck, 1999).

4.2.4 Polyreference least square complex frequency domain (pLSCF)

In Zhang et al. (2005) a tracking of the development of pLSCF method from the FVT to the AVT can be found, a summary is presented here. Guillaume et al (1998) used the Least Squares Complex Frequen-

cy-domain (LSCF) estimation method to find initial values for the iterative maximum likelihood method which was proposed for modal identification from FRF in FVT context. It was found that these initial values resulted in accurate modal parameters with small computational effort; nevertheless, LSCF had two limitations. First, the mode shapes are difficult to obtain using the SVD. Second, the closely spaced modes are difficult to separate. Therefore, Guillaume et al (2003) presented a polyreference version of the LSCF method, based on right matrix-fraction model to overcome the above limitations and short time after Peeters and Van der Auweraer (2005) presented the polyreference Least Square Complex Frequency domain (pLSCF) for AVT.

The main advantages of the pLSCF are: 1) it is fast; 2) it yields a very clear stabilization diagram; 3) the numerical stability of the algorithm allows for a large-bandwidth and high-model order analysis and makes it suitable both for lowly- and highly-damped structures. The main drawback is that the damping estimates associated with some stable poles decrease with increasing noise levels and this situation be-

comes worth for poorly excited modes (El-Kafafy et al., 2013; Peeters et al., 2012; Peeters, 2000).

5. CONCLUSIONS

This paper presented the recent state-of-the-art of many interconnected activities usually carried out in an integrated methodology to help in the seismic assessment of a historical structure. In the following the main conclusions concerning each of these activities are presented.

On the dynamic identification tests: For modern structures, these tests are useful to 1) give insight about their dynamic behavior, 2) find out if their performance fall within particular criteria, 3) detect signs of damage and 4) propose guidance for improved future modeling and/or design.

For historical structures, these tests are used to 1) obtain modal parameters of the structure, 2) update the numerical model of the structure, 3) assess the level of connection between different parts of the structure partially separated by cracks, 4) reveal the damage effect on dynamic behavior, 5) appraise the benefits of repair/strengthening interventions and 6) select the optimal sensors locations for the following dynamic monitoring activity.

AVT is more used than FVT in the dynamic identification of historical structures because it is quicker and cheaper, less equipments and operators are needed, and tests can be realized while a structure is in service. However, it has some limitations, for instance, the difficulty in exciting some modes, the assumption of stationary white noise excitation and the low signal to noise ratio. Therefore, these limitations require the usage of robust output-only dynamic identification methods.

The sensors are selected based on many aspects; above all are the frequency range, the dynamic range and the sensitivity.

In AVT, the testing time should not be less than 1000 to 2000 times structure's fundamental period.

It is important to carry out the modal parameters identification process using more than one dynamic identification method. In spite of this, normally damping will be a difficult parameter to determine. Moreover, some modes may not be identified due to low excitation levels.

The identification of structures with one predominant direction like bridges and bell towers is easier than in more complex structures like churches and cathedrals.

On the dynamic monitoring of historical structures: Monitoring is carried out to 1) study the evolution of modal parameters in time, 2) reveal the effect of environmental actions on modal parameters, 3) capture the dynamic response in the vicinity of possible seismic events and 4) verify the effective-

ness of any possible intervention, specifically the incremental intervention.

The dynamic monitoring systems are classified according to the type of used instrument into wired systems and wireless systems. The first systems are still widely in use, and more research is still in need for facilitating and increasing the usage of the second systems. According to the activation regime of the recording devices, there are three types of systems: dynamic monitoring system with threshold, periodical dynamic monitoring system and continuous dynamic monitoring. Although the last system gives more information than the other two systems, it is not widely used because it needs large storage capacity and more post processing.

Some of the few available case studies in the literature have been discussed. Based on these cases, it can be concluded that 1) the natural frequencies increase with the temperature due to the closing of cracks and vice versa, 2) under the effect of a seismic event with a considerable magnitude, the natural frequencies decrease and they may recover their initial value after the event if no residual damage has occurred, 3) the damping ratios increase significantly during a seismic events of a considerable magnitude, 4) mode shapes change lesser than natural frequencies and damping ratios under the effect of earthquakes.

The automated dynamic identification of modal parameters from dynamic monitoring data is a new trend that it is highly needed to speed up the identification process by reducing the amount of human interfering.

On the modal parameters identification methods: Some basic concepts of signal processing like sampling, white noise, signal conditioning, spectral analysis and Fast Fourier Transform (FFT) were introduced. From these concepts, the following can be concluded 1) the sampling rate must be chosen to be five to ten times the signal's highest frequency component otherwise the aliasing error may occur, 2) windows like Hanning are applied to signals to reduce leakage error, 3) filters are applied to reduce noise in signals by removing some unwanted frequencies, 4) decimation reduces the time of processing a signal without losing any information it contains.

Five modal parameters identification methods were discussed. Those are the PP, the FDD, the SSI-COV, the SSI-DATA and the pLSCF. For each of them the background theory was briefly given and a focus was made on the advantages and the limitations of each method.

The PP method is fast and user friendly but it is not efficient in case of closely spaced modes. Moreover, picking the peaks is always a subjective task.

The FDD method allows for the accurate separation of closely spaced modes but its results are satisfactory in condition that the excitation is a white noise, the structure is lightly damped and the mode shapes of closely spaced modes are geometrically orthogonal. Also, it cannot estimate the damping ratios. The SSI methods are more accurate than the PP and the FDD; however, they don't afford an absolute scaling of the identified mode shapes. The pLSCF method yields a very clear stabilization diagram, compared to the SSI method. Nevertheless, the damping estimates associated with some stable poles decrease with increasing noise levels and this situation becomes worth for poorly excited modes.

ACKNOWLEDGEMENTS

This research has been carried out within the project "New Integrated Knowledge based approaches to the protection of cultural heritage from Earthquake-induced Risk-NIKER" funded by the European Commission (Grant Agreement n° 244123), whose assistance is gratefully acknowledged.

REFERENCES

- Aguilar, R. (2010). Dynamic structural identification using wireless sensor networks. PhD Thesis, University of Minho, Portugal.
- Alaboz, M. (2009). Dynamic identification and modal updating of St. Torcato church. MSc Thesis, University of Minho, Portugal.
- Andersen, P., Brincker, R., Peeters, B., De Roeck, G., Hermans, L., & Krämer, C. (1999). Comparison of system identification methods using ambient bridge test data. In *Proc. of the 17th International Modal Analysis Conference (IMAC)*, 8-11 February, Orlando, Florida, USA.
- Angotti, F., Vignoli, A., Giuseppetti, G. & Panzeri, P. (1992). Experimental evaluation of the dynamic behaviour of a stone masonry building causing progressive damage. In *Proc. of the 10th World Conference on Earthquake Engineering*, Madrid, Spain.
- Antonelli, K., Astakhov, V. P., Bandyopadhyay, A., Bhatia, V., Claus, R. O., Dayton, D., Eren, H., Hyatt, R.M., Janas, V.F., Karlsson, N, Khokine, A, Ko, J., Kong, W.L, Ku, S., Mayer, J.R.R, Nyce, D.S., & Pedersen, T. O. (1999). Displacement measurement, linear and angular. In Webster, J. G. (Ed-in-Chief), *The Measurement, Instrumentation, and Sensors Handbook*. Boca Raton, Florida: CRC Press LLC.
- Aoki, T., Sabia, D., & Rivella, D. (2008). Influence of experimental data and FE model on updating results of a brick chimney. *Advances in Engineering Software*, 39(4), 327-335.
- Araiza, J. C. (2003). Dynamic assessment of structural building components. PhD Thesis, Technical University of Catalonia, Spain.
- Armstrong, D., Sibbald, A., Fairfield, C. & Forde, M. (1995). Modal analysis for masonry arch bridge spandrel wall separation identification. *NDTandE International*: 28 (6), pp. 377--386.
- Atamturktur, S., Pavic, A., Reynolds, P., & Boothby, T. (2009). Full scale modal testing of vaulted gothic churches: lessons learned. *Experimental Techniques*, 33(4): 65-74.
- Avitabile, P. (2001). Experimental modal analysis - a simple non-mathematical presentation. *Sound and vibration*, 35(1):20-31.
- Bayraktar, A., Altunışik, A. C., Sevim, B., & Turker, T. (2011). Seismic response of a historical masonry minaret using a finite element model updated with operational modal testing. *Journal of Vibration and Control*, 17(1), 129-149.
- Bendat, J.S. & Piersol, A.G. (1993). *Engineering Applications of Correlation and Spectral Analysis*, New York: Wiley.
- Bensalem, A., Ali-Ahmed, H., Fairfield, C. A. & Sibbald, A. (1998). Non-destructive testing as a tool for detection of gradual safety factor deterioration of loaded arches. *Arch Bridges*, Anna Sinopoli (Eds.), A.A. Balkema, Rotterdam, 271-279.
- Bensalem, A., Fairfield, C. & Sibbald, A. (1995). Non-destructive testing for arch bridge assessment. In *proc. of the 1st international conference on arch bridges*, UK, pp. 459-468.
- Bernal, D. & Gunes, B. (2002). Damage localization in output-only systems: a flexibility based approach. In *Proc. of the 20th International Modal Analysis Conference (IMAC)*, February 4-7, Los Angeles, California, pp. 1185-1191.
- Bernal, D. (2003). Normalization of modes in operational modal analysis. In the *4th Intentional workshop on Structural Health Monitoring*. Stanford University. Stanford. CA, pp. 475-482.

- Board of the Alhambra and Generalife. (2012). Presupuesto de la comunidad autónoma de Andalucía. Patronato de la Alhambra y Generalife. Retrieved on 15th September 2014 from http://www.juntadeandalucia.es/haciendayadministracionpublica/planif_presup/presupuesto2012/estado/programas/programas-e-36.pdf
- Brincker, R., Zhang, L., & Andersen, P. (2000a). Output-Only Modal Analysis by Frequency Domain Decomposition. In P. Sas & D. Moens (Eds.), *Proc. of ISMA25: International Conference on Noise and Vibration Engineering*, Katholieke Universiteit, Leuven, pp. 717-723.
- Brincker, R., Zhang, L., & Andersen, P. (2000b). Modal identification from ambient responses using frequency domain decomposition. In *Proc. of the 18th International Modal Analysis Conference (IMAC)*, 7-10 February, San Antonio, Texas, USA.
- Brincker, R., Zhang, L., & Andersen, P. (2001a). Modal identification of output-only systems using frequency domain decomposition. *Smart Materials and Structures*, 10(3), 441-445.
- Brincker, R.; Ventura, C. & Andersen, P. (2001b). Damping estimation by Frequency Domain Decomposition. In *Proc. of 19th International Modal Analysis Conference (IMAC)*, 5-8 February, Orlando, Florida, USA.
- Brincker, R., Ventura, C. & Andersen, P. (2003a). Why output-only modal testing is a desirable tool for a wide range of practical applications. In *Proc. of the 21st International Modal Analysis Conference (IMAC)*, February 3-6, Kissimmee, Florida, USA.
- Brincker, R., & Andersen, P. (2003b). A way of getting scaled mode shapes in output only modal testing. In *Proc. of 21st International Modal Analysis Conference (IMAC)*, February 3-6, Kissimmee, Florida, USA.
- Brincker, R. & Andersen, P. (2006). Understanding Stochastic Subspace Identification. In *Proc. of 24th International Modal Analysis Conference (IMAC)*, January 29 – February 2, St. Louis, Missouri, USA.
- Cabboi, A. (2014). Automatic operational modal analysis: challenges and applications to historic structures and infrastructures. PhD Thesis, University of Cagliari, Italy.
- Cabboi, A., Gentile, C. & Saisi, A. (2013a). Frequency tracking and F.E. model identification of a masonry tower. *Proc. of the Int. Conf. IOMAC 2013*, 14 - 15 May, Guimaraes, Portugal.
- Cabboi, A., Gentile, C. & Saisi, A. (2014). Automated modal and structural identification of a stone-masonry bell-tower for SHM. In *Proc. of the 9th International Conference on Structural Dynamics*, 30 June-2 July, Porto, Portugal.
- Cabboi, A., Magalhães, F., Gentile, C. & Cunha, A. (2013b). Automatic operational modal analysis: Challenges and practical application to a historic bridge. In *Proc. 6th ECCOMAS conference on Smart Structures and Materials*, 24-26 June, Torino, Italy.
- Cantieni R. (2005). Experimental methods used in system identification of civil engineering structures. *1st International Operational Modal Analysis Conference (IOMAC)*, 26-27 April, Copenhagen, Denmark. pp. 249-260.
- Capecchi, D., Vestroni, F. & Antonacci, E. (1990). Experimental study of dynamic behaviour of an old masonry building. *9th European Conf. on Earth. Eng.*, Moscow.
- Carder, D. S. (1936b). Observed vibrations of buildings. *Bulletin of the Seismological Society of America*, 26(3), 245-277.
- Carder, D. S. (1937). Observed vibration of bridges. *Bulletin of the Seismological Society of America*, 27(4), 267-89.
- Carder, D.S. (1936a). Vibration observations. Chapter 5 in *Earthquake Investigations in California 1934-1935*. U.S. Dept. of Commerce, Coast and Geologic Survey, Special Publication No. 201, Washington, D.C., U.S.A.
- Carne, T. G. & Stasiunas, E. C. (2006). Lessons learned in modal testing – part 3: Transient excitation for modal testing, more than just hammer impacts. *Experimental Techniques*, 30(3), 69-79.
- Casarin, F. (2006). Structural assessment and seismic vulnerability analysis of a complex historical building. PhD Thesis, University of Trento/ University of Padova, Italy.
- Casarin, F. & Modena, C. (2006). Structural assessment and seismic vulnerability analysis of the Reggio Emilia cathedral, Italy. In Lourenço, P., Roca, P., Modena, C. and Argawal, S. (Eds.), *Structural analysis of historical constructions*, pp. 1263-1270.
- Casarin, F. & Modena, C. (2008). Seismic assessment of complex historical buildings: Application to Reggio Emilia Cathedral, Italy. *International Journal of Architectural Heritage*, 2 (3), pp. 304-327.
- Caselles, O., Clapes, J., Roca, P. & Elyamani, A. (2012). Approach to seismic behavior of Mallorca cathedral. *15th World Conference of Earthquake Engineering*, Lisbon, Portugal, 24-28 September 2012.

- Chiostrini, S., Foraboschi, P. & Vignoli, A. (1992). Structural analysis and damage evaluation of existing masonry buildings by dynamic experimentation and numerical modelling. In *Proc. of the 10th World Conference on Earthquake Engineering*, pp. 3481-3486.
- Chiostrini, S., Foraboschi, P., Vignoli, A., Galimberti, M., Meneghella, M. & Penzeri, P. (1991). Prove di vibrazioni forzate su un edificio in muratura: danneggiamento e non linearità. In *5th Congress of seismic engineering in Italy*, Palermo (pp. 601-610).
- Chrysostomou, C., Kyriakides, N., Kappos, A., Kouris, L., Georgiou, E. & Millis, M. (2013). Seismic retrofitting and health monitoring of school buildings of Cyprus. *Open Construction and Building Technology Journal*, 7, pp.208-220.
- Corbi, O., Zaghw, A. H., Elattar, A. & Saleh, A. (2013). Preservation provisions for the environmental protection of Egyptian monuments subject to structural vibrations. *International Journal of Mechanics*, 7(3): 172-179.
- Correa, M.R. & Costa, A.C. (1992). Dynamic tests of the bridge over the Arade River. In: Fernandes, J.A. and Santos, L.O. (Eds.), *Cable-stayed Bridges of Guadiana and Arade*, LNEC.
- Crawford, R. & Ward, H.S. (1964). Determination of the Natural Periods of Building. *M. Seism. Soc. Amer.*, Vol. 54, pp. 1743-1756.
- Cunha, Á. & Caetano, E. (2006). Experimental modal analysis of civil engineering structures. *Sound and Vibration*, 40(6), 12-20.
- Cunha, Á., Caetano, E., Magalhães, F. & Moutinho, C. (2006). From input-output to output-only modal identification of civil engineering structures. *1st International Operational Modal Analysis Conference (IOMAC)*, 26-27 April, Copenhagen, Denmark.
- Cunha, Á., Caetano, E., Magalhães, F., & Moutinho, C. (2013). Recent perspectives in dynamic testing and monitoring of bridges. *Structural Control and Health Monitoring*, 20(6), 853-877.
- D10.4-NIKER. (2012). Guidelines for Reliable Seismic Analysis and Knowledge Based Assessment of Buildings. Report, work package 10, NIKER project (2010-2012): New Integrated Knowledge-based approaches to the protection of cultural heritage from Earthquake-induced Risk. Funded by EC under the 7th Framework program, contract n. ENV2009-1-GA244123.
- D9.4-NIKER. (2012). Report on the Use of Monitoring as Knowledge Based Assessment and Early Warning Tool. Report, work package 9, NIKER project (2010-2012): New Integrated Knowledge-based approaches to the protection of cultural heritage from Earthquake-induced Risk. Funded by EC under the 7th Framework program, contract n. ENV2009-1-GA244123.
- Dai, K., Opinel, P.A. & Huang, Y. (2013). Field dynamic testing of civil infrastructure-literature review and a case study. In *5th international conference on advances in experimental structural engineering*. November 8-9, Taipei, Taiwan.
- De Matteis, G., Langone, I., Colanzi, F. & Mazzolani, F. M. (2007). Experimental and numerical modal identification of the Fossanova Gothic cathedral. *Key Engineering Materials*, 347, 351-358.
- De Matteis, G. & Mazzolani, F. M. (2010). The Fossanova Church: seismic vulnerability assessment by numeric and physical testing. *International Journal of Architectural Heritage*, 4(3), 222-245.
- De Matteis, G., Colanzi, F., Eboli, A. & Mazzolani, F. M. (2008). Seismic vulnerability evaluation of the Fossanova Gothic church. In D'Ayala D. and Fodde E. (ed) *Structural Analysis of Historical Construction*. CRC Press Balkema, pp. 1225-1235.
- De Silva, C. W. (2007). *Vibration – Fundamentals and Practice*, 2nd Edition, Taylor and Francis/CRC Press, Boca Raton, FL.
- De Stefano, A., & Ceravolo, R. (2007). Assessing the health state of ancient structures: the role of vibrational tests. *Journal of Intelligent Material Systems and Structures*, 18(8), 793-807.
- Dolce, M. (2009). The Abruzzo earthquake: effects and mitigation measures. *Disaster prevention workshop*, Stockholm, Hasselbacken, 27-29 July.
- Durukal, E. (1992). Structural identification and seismic vulnerability assessment of Aya Sofya. MSc Thesis, Bogazici University, Turkey.
- El-Kafafy, M., Guillaume, P., & Peeters, B. (2013). Modal parameter estimation by combining stochastic and deterministic frequency-domain approaches. *Mechanical Systems and Signal Processing*, 35(1), 52-68.
- Ellis, B. R. (1998). Non-destructive dynamic testing of stone pinnacles on the Palace of Westminster. Proc. of the institution of civil engineers. *Structures and buildings*, 128(3), 300-307.
- Elyamani A. (2015) Integrated monitoring and structural analysis strategies for the study of large historical construction. Application to Mallorca cathedral. PhD thesis, Technical University of Catalonia, Spain.

- Elyamani, A., Caselles, O., Roca, P., & Clapes, J. (2017a). Dynamic investigation of a large historical cathedral. *Structural Control and Health Monitoring*, 24(3).
- Elyamani, A., Roca, P., Caselles, O. & Clapes, J. (2017b) Seismic safety assessment of historical structures using updated numerical models: The case of Mallorca cathedral in Spain. *Engineering Failure Analysis* 74, 54-79. DOI: 10.1016/j.engfailanal.2016.12.017.
- Erdik, M. & Durukal, E. (1996). Use of strong motion data for the assessment of the earthquake response of historical monuments. *Proc. 11th World Conference on Earthquake Engineering*, 23-28 June, Acapulco, Mexico.
- Erdik, M., & Durukal, E., Yuzugullu, B., Beyen, K. & Kadakal, U. (1993). Strong-motion instrumentation of Aya Sofya and the analysis of response to an earthquake of 4.8 magnitude. *Proc. of the 3rd Conference: Structural Repair and Maintenance of Historical Buildings III*, Bath, UK, pp. 99-114.
- Eren, H. (1999). Acceleration, vibration, and shock measurement. In Webster, J. G. (Ed-in-Chief), *The Measurement, Instrumentation, and Sensors Handbook*. Boca Raton, Florida: CRC Press LLC.
- Ewins, D.J. (2000a). *Modal testing, theory, practice and application*. Second Edition, Research Studies Press LTD, Hertfordshire, England.
- Ewins, D. J. (2000b). *Basics and state-of-the-art of modal testing*. *Sadhana*, 25(3), 207-220.
- Felber, A. J. (1993). Development of a hybrid bridge evaluation system. PhD Thesis, University of British Columbia, Vancouver, Canada.
- Gaudini, G., Modena, C., Casarin, F., Bettio, C. & Lucchin, F. (2008). Monitoring and strengthening interventions on the stone tomb of Cansignorio della Scala, Verona, Italy. In *Proc. of the 6th International Conference on Structural Analysis of Historical Constructions*, 2-4 July, Bath, UK, pp. 403-411.
- Genovese, F. & Vestroni, F. (1998). Identification of dynamic characteristics of a masonry building. In *Proc. of the 11th European Conference on Earthquake Engineering*, Paris, France
- Gentile, C., & Saisi, A. (2013). Operational modal testing of historic structures at different levels of excitation. *Construction and Building Materials*, 48, 1273-1285.
- Government of Andalusia. (2013). Turismo Cultural en Andalucía. Informe Annual. Retrieved on 15th September 2014 from www.andalucia.org/media/tinyimages/file/Turismo_Cultural_2013.pdf.
- Guillaume, P., Verboven, P. & Vanlanduit, S. (1998). Frequency-domain maximum likelihood identification of modal parameters with confidence intervals. In *Conference Proc. of the 23rd International Seminar on Modal Analysis*, Leuven, Belgium.
- Guillaume, P., Verboven, P., Vanlanduit, S., Van Der Auweraer, H. & Peeters, B. (2003). A poly-reference implementation of the least-squares complex frequency-domain estimator. In *Proc. of IMAC* (Vol. 21, pp. 183-192).
- Heylen, W. & Sas, P. (2006). *Modal Analysis Theory and Testing*. Katholieke Universteit Leuven, Departement Werktuigkunde.
- Hu, W. H. (2012). Operational modal analysis and continuous dynamic monitoring of footbridges. PhD Thesis, University of Porto, Portugal.
- Hu, W. H., Cunha, Á., Caetano, E., Magalhães, F., & Moutinho, C. (2010). LabVIEW toolkits for output-only modal identification and long-term dynamic structural monitoring. *Structure and Infrastructure Engineering*, 6(5), 557-574.
- Ivanovic, S. S., Trifunac, M. D. & Todorovska, M. I. (2000). Ambient vibration tests of structures—a review. *ISET Journal of Earthquake Technology*, 37(4): 165-197.
- Ivorra, S., Pallares, F. J. & Adam, J. M. (2011). Masonry bell towers: dynamic considerations. *Structures and Buildings*, Vol. 164, Issue SB1, February 2011.
- Jamal, R. & Steer, R. (1999). Filters. In Webster, J. G. (Ed-in-Chief), *The Measurement, Instrumentation, and Sensors Handbook*. Boca Raton, Florida: CRC Press LLC.
- James, G. H., Carne, T. G., Lauffer, J. P. & Nard, A. R. (1992). Modal testing using natural excitation. *10th International Modal Analysis Conference (IMAC)*, 3-7 February, San Diego, USA.
- Kadakal, U. & Yuzugullu, O. (1996). A comparative study of the identification methods, for the autoregressive modeling from the ambient vibration records. *Soil Dynamics and Earthquake Eng.*, Vol. 15, No. 1, pp. 45-49.
- Kammer, D. C. (1991). Sensor placement for on-orbit modal identification and correlation of large space structures. *Journal of Guidance, Control, and Dynamics*, 14(2), 251-259.
- Kulkarni, S.R. (2014). Information signals. Course notes. Retrieved from http://www.princeton.edu/~cuff/ele201/kulkarni_text/signals.pdf
- Lent, B. (2009). Simple steps to selecting the right accelerometer. *Sensors Magazine* 26(3), March issue.

- Llorens, M., Mata, P., Araiza, J. C. & Roca, P. (2001). Damage characterization in stone columns by dynamic test. Application to the Cloister of Girona Cathedral, Spain. In: Lourenço, P.B. and Roca, P. (Eds.) *Historical Constructions*, University of Minho, Guimarães, 469-478.
- Loewenstein, E.B. (1999). Analog-to-digital converters. In Webster, J. G. (Ed-in-Chief), *The Measurement, Instrumentation, and Sensors Handbook*. Boca Raton, Florida: CRC Press LLC.
- Lorenzoni, F. (2013). Integrated methodologies based on structural health monitoring for the protection of cultural heritage buildings. PhD Thesis, University of Trento, Italy.
- Lorenzoni, F., Casarin, F., Modena, C., Caldon, M., Islami, K. and Da Porto, F. (2013). Structural health monitoring of the Roman Arena of Verona, Italy. *Journal of Civil Structural Health Monitoring*, 3 (4), pp. 227 – 246.
- Lourenço, P. B., Trujillo, A., Mendes, N. & Ramos, L. F. (2012). Seismic performance of the St. George of the Latins church: Lessons learned from studying masonry ruins. *Engineering structures*, 40, 501-518.
- Magalhães, F. (2010). Operational modal analysis for testing and monitoring of bridges and special structures. PhD Thesis. University of Porto, Portugal.
- Magalhães, F., Cunha, Á., Caetano, E., & Brincker, R. (2010). Damping estimation using free decays and ambient vibration tests. *Mechanical Systems and Signal Processing*, 24(5), 1274-1290.
- Magalhães, F. & Cunha, Á. (2011). Explaining operational modal analysis with data from an arch bridge. *Mechanical systems and signal processing*, 25(5), 1431-1450.
- Maia, N. & Silva, J. (1997). Theoretical and experimental modal analysis, Research Studies Press Ltd.
- Maia, N. & Silva, J. (2001). Modal analysis identification techniques. *Philosophical Transactions of the Royal Society of London. Series A: Mathematical, Physical and Engineering Sciences*, 359(1778), 29-40.
- Masjedjian, M. H., & Keshmiri, M. (2009). A review on Operational Modal Analysis researches: classification of methods and applications. *3rd International Operational Modal Analysis Conference*, May 4 - 6, Portonovo, Italy, pp. 707-718.
- MC (2005). Measurement Computing, USA, *Data acquisition handbook*, 3rd Edition, Retrieved from: www.mccdaq.com/support/data-acquisition-handbook.aspx.
- McConnell, K. G. & Varoto, P. S. (1995). *Vibration testing: theory and practice*. New York: Wiley.
- Meli, R., Rivera, D. & Miranda, E. (2001). Measured seismic response of the Mexico City Cathedral. In: Lourenço, P.B. and Roca, P. (Eds.) *Historical Constructions*, University of Minho, Guimarães, pp. 877-886.
- Mendoza, L., Reyes, A. and Luco, J.E. (1991). Ambient vibration tests of Mexicali general hospital. *Earthquake Spectra*, 7(2), pp. 281-300.
- Michel, C., Guéguen, P. & Bard, P. Y. (2008). Dynamic parameters of structures extracted from ambient vibration measurements: An aid for the seismic vulnerability assessment of existing buildings in moderate seismic hazard regions. *Soil Dynamics and Earthquake Engineering*, 28(8), 593-604.
- Ministry of industry, energy and tourism. (2012). Movimientos Turísticos en Fronteras (Frontur) y Encuesta de Gasto Turístico (Egatur). Retrieved on 15th September 2014 from <http://www.iet.tourspain.es/es-es/estadisticas/frontur/Paginas/default.aspx>.
- Modena, C., Rossi, P. P., Zonta, D. (1997). Static and dynamic investigation on the roman amphitheatre (Arena) in Verona. *Proc., IABSE Int. Colloquium "Inspection and Monitoring of the Architectural Heritage"*, Seriate, 1997, Ferrari Ed., Clusone (BG), pp. 73-80.
- Moreno-Gomez, A., Perez-Ramirez, C. A., Dominguez-Gonzalez, A., Valtierra-Rodriguez, M., Chavez-Alegria, O. and Amezcua-Sanchez, J. P. (2017). Sensors used in structural health monitoring. *Archives of Computational Methods in Engineering*, DOI: 10.1007/s11831-017-9217-4.
- Mulhern, M.R & Maley, R.P. (1973). Building Period Measurements before, during and after the San Fernando, California, Earthquake of February 9, 1971. U.S. Depart. of Commence, National Oceanic and Atmospheric Administration, Washington, D.C., U.S.A., Vol. 1, Part B, pp. 725-733.
- Nasser, M. A. (2001). Dynamic analysis of arched style masonry structures. In *IMAC-XIX: A Conference on Structural Dynamics*, (Vol. 2, pp. 1363-1369).
- Orfanidis, S. J. (1996). Introduction to signal processing. Englewood Cliffs, N.J.: Prentice Hall.
- Pallas-Areny, R. (1999). Amplifiers and signal conditioners. In Webster, J. G. (Ed-in-Chief), *The Measurement, Instrumentation, and Sensors Handbook*. Boca Raton, Florida: CRC Press LLC.
- Parloo, E., Guillaume, P. & Van Overmeire, M. (2002). Sensitivity-based operational mode shape normalisation. *Mechanical Systems and Signal Processing*, 16(5), 757-767.
- Pau, A. & Vestroni, F. (2008). Vibration analysis and dynamic characterization of the Colosseum. *Structural Control and Health Monitoring*: 15 (8), pp. 1105-1121.

- Pau, A. & Vestroni, F. (2013). Vibration assessment and structural monitoring of the Basilica of Maxentius in Rome. *Mechanical Systems and Signal Processing*, 41(1), 454-466.
- Pau, A., & Vestroni, F. (2011). Dynamic characterization of ancient masonry structures. *Advances in Vibration Analysis Research*, Intech, 213-230.
- Peeters, B. & De Roeck, G. (1999). Reference-based stochastic subspace identification for output-only modal analysis. *Mechanical Systems and Signal Processing*, 13(6): 855-878.
- Peeters, B. (2000). System identification and damage detection in civil engineering. PhD Thesis, Katholieke Universiteit Leuven, Belgium.
- Peeters, B. & De Roeck, G. (2001). Stochastic system identification for operational modal analysis: a review. *Journal of Dynamic Systems, Measurement, and Control*, 123(4), pp.659-667.
- Peeters, B., Van der Auweraer, H., Guillaume, P. & Leuridan, J. (2004). The PolyMAX Frequency-Domain Method: a new standard for modal parameters estimation? *Shock and Vibration* (11), 395-409.
- Peeters, B. & Van der Auweraer, H. (2005). PolyMAX: a revolution in operational modal analysis. In: Brincker R, Møller N (Eds.) *1st International Operational Modal Analysis Conference (IOMAC)*, 26-27 April, Copenhagen, Denmark. , pp 41-52.
- Peeters, B., El-kafafy, M. & Guillaume, P., (2012). The new PolyMAX Plus method: confident modal parameter estimation even in very noisy cases. *International Conference on Noise and Vibration Engineering*, 17-19 September, Leuven, Belgium.
- Pereira, A. S. (2009). The opportunity of a disaster: the economic impact of the 1755 Lisbon earthquake. *The Journal of Economic History*, 69(02), 466-499.
- Prabhu, S. (2011). Structural health monitoring of historic masonry monuments. MSc Thesis, Clemson University, USA.
- Prabhu, S. and Atamturktur, S. (2013). Selection of optimal sensor locations based on modified effective independence method: case study on a gothic revival cathedral. *Journal of Architectural Engineering*, 19(4), 288-301.
- Prevosto, M. (1982). Algorithmes d'identification des caractéristiques vibratoires de structures mécaniques complexes. Ph.D. Thesis, Université de Rennes I, France.
- Pusey, H. C. (2008). An historic view of shock and vibration. In *Proc. of the 26th International Modal Analysis Conference (IMAC)*, Orlando, Florida, 2-5 February.
- Ramos, L.F., Marques, L., Lourenço, P.B., De Roeck, G. Campos-Costa, A. & Roque, J. (2010). Monitoring historical masonry structures with operational modal analysis: two case studies. *Mechanical systems and signal processing*: 24 (5), pp. 1291-1305.
- Ramos, L. F., Aguilar, R., Lourenço, P. B., & Moreira, S. (2013). Dynamic structural health monitoring of Saint Torcato church. *Mechanical Systems and Signal Processing*, 35(1), 1-15.
- Reist, P. (2013). Signals and Systems. Course notes. Retrieved from http://www.idsc.ethz.ch/Courses/signals_and_systems/LectureNotes/2013_SS_Lecture8.pdf
- Ren, W. X. & Zong, Z. H. (2004). Output-only modal parameter identification of civil engineering structures. *Structural Engineering and Mechanics*, 17(3-4), 429-444.
- Reynolds, P. (2008). Dynamic testing and monitoring of civil engineering structures. *Experimental Techniques*, 32(6): 54-57.
- Rivera, D., Meli, R., Sánchez, R. & Orozco, B. (2008). Evaluation of the measured seismic response of the Mexico City Cathedral. *Earthquake Engineering and Structural Dynamics*, 37(10), 1249-1268.
- Roca, P. & Molins, C. (1997). Dynamic load tests on masonry structures as inspection technique. Inspection and Monitoring of the Architectural Heritage. *IABSE 1997. Italian Group of IABSE Ferrari Editrice*, p. 133-140.
- Russo, S. (2013a). On the monitoring of historic Anime Sante church damaged by earthquake in L'Aquila. *Structural Control and Health Monitoring*, 20 (9), pp. 1226-1239.
- Salawu, O. S. & Williams, C. (1995). Bridge assessment using forced-vibration testing. *Journal of Structural Engineering*, 121(2), 161-173.
- Sena-Cruz, J., Ferreira, R. M., Ramos, L. F., Fernandes, F., Miranda, T., & Castro, F. (2013). Luiz Bandeira bridge: assessment of a historical reinforced concrete (RC) bridge. *International Journal of Architectural Heritage*, 7(6), 628-652.
- Sharma, G (2014). Digital signal processing. Course notes. Retrieved from nptel.ac.in/courses/Webcourse-contents/IIT-KANPUR/Digi_Sigi_Pro/ui/TOC.htm.

- Shih, C.Y., Tsuei, Y.G., Allemang, R.J. & Brown, D.L. (1988). Complex mode indicator function and its application to spatial domain parameter estimation. *Mechanical Systems and Signal Processing* 2 (4), 367-377.
- Sigmund, V. A. & Herman, K., (1998). Dynamic characteristics as indicators of structural integrity. *ABSE Colloquium*, IABSE Report Volume 77. Berlin
- Sinha, J. K. (2005). On standardization of calibration procedure for accelerometer. *Journal of Sound and Vibration*, 286(1), 417-427.
- Slastan, J. A. & Foissner P. (1995). Masonry building dynamic characteristics evaluation by means of ambient vibration. In *Proc. of the 10th European Conference on Earthquake Engineering*, Vienna, Austria.
- Smith, S. W. (2002). The scientist and engineer's guide to digital signal processing. San Diego, Calif.: California Technical Pub.
- Trifunac, M.D. (1970a). Ambient Vibration Test of a 39-Story Steel Frame Building. *Report EERL 70-02, Earthq. Eng. Res. Lab.*, Calif. Institute of Tech., Pasadena, California, U.S.A.
- Trifunac, M.D. (1970b). Wind and Microtremors Induced Vibrations of a 22-Story Steel Frame Building. *Report. EERL 70-011, Earthq. Eng. Res. Lab.*, Calif. Institute of Tech., Pasadena, California, U.S.A.
- Trifunac, M.D. (1972). Comparison between Ambient and Forced Vibration Experiments. *Earthquake Eng. and Structural Dynamics*, Vol. 1, pp. 133-150.
- Tzenov, L. & Dimova, S. (1992). Experimental Study of the Church 'Sveta Sofia'. In *Proc. of 10th World Conference on Earthquake Engineering*, Madrid, 19-24 July, pp. 3403-3408.
- Underwood, M. & Keller, T. (2008a). Testing civil structures using multiple shaker excitation techniques. *Sound and Vibration*, 42(4), 10-15.
- Underwood, M. & Keller, T. (2008b). Some applications for the testing of civil structures using multiple shaker excitation techniques. In *Proc. of 26th International Modal Analysis Conference (IMAC)*, Orlando, Florida, 2-5 February.
- Van Overschee, P. & De Moor, B. (1996). *Subspace Identification for Linear Systems*, Kluwer Academic Publishers, Leuven, Belgium.
- Verhaegen, M., & Verdult, V. (2007). Filtering and system identification: a least squares approach. Cambridge university press.
- Vestroni F., Beolchini G. C., Antonacci E. & Modena C., (1996). Identification of dynamic characteristics of masonry buildings from forced vibration tests. In *Proc. of the 11th World Conference on Earthquake Engineering*, Acapulco, México.
- Votsis, R. A., Kyriakides, N., Chrysostomou, C. Z., Tantele, E. & Demetriou, T. (2012). Ambient vibration testing of two masonry monuments in Cyprus. *Soil Dynamics and Earthquake Engineering*, 43, 58-68.
- Votsis, R. A., Kyriakides, N., Tantele, E. & Chrysostomou, C. Z. (2013). Effect of damage on the dynamic characteristics of St. Nicholas cathedral in Cyprus. In *Proc. of ECCOMAS - Conference on Computational Methods in Structural Dynamics and Earthquake Engineering*, Kos Island, Greece, 12-14 June.
- Walter, P. L. (1997). The history of the accelerometer. *Sound and Vibration*, 31(3), 16-23.
- Walter, P. L. (1999). Review: Fifty years plus of accelerometer history for shock and vibration (1940-1996). *Shock and Vibration*, 6(4), 197-207.
- Walter, P. L. (2002). A history of the origin and evolution of modal transducers. In *SPIE proceedings series*. Society of Photo-Optical Instrumentation Engineers.
- Ward, H.S. & Crawford, R. (1966). Wind Induced Vibrations and Building Modes. *M. Seism. Soc. Amer.*, Vol. 50, pp. 793-813.
- Wilson, J. (1999). A practical approach to vibration detection and measurement. Part 2: dynamic and environmental effects on performance. *Sensors Magazine*, 16(2).
- Zhang, L., Brincker, R. & Andersen, P. (2005). An overview of operational modal analysis: major development and issues. *1st International Operational Modal Analysis Conference (IOMAC)*, 26-27 April, Copenhagen, Denmark.