



Title	Singularities of ruled surfaces in $R^3$
Author(s)	Izumiya, S.; Takeuchi, N.
Citation	Hokkaido University Preprint Series in Mathematics, 458, 1-11
Issue Date	1999-5-1
DOI	10.14943/83604
Doc URL	<a href="http://hdl.handle.net/2115/69208">http://hdl.handle.net/2115/69208</a>
Type	bulletin (article)
File Information	pre458.pdf



[Instructions for use](#)

# Singularities of ruled surfaces in $\mathbb{R}^3$

Shyuichi Izumiya    Nobuko Takeuchi

Series # 458. May 1999

# Singularities of ruled surfaces in $\mathbb{R}^3$

Shyuichi Izumiya  
Department of Mathematics,  
Hokkaido University,  
Sapporo 060-0810, Japan

Nobuko Takeuchi  
Department of Mathematics,  
Tokyo Gakugei University,  
Koganei, Tokyo 184-8501, Japan

May 17, 1999

## Abstract

We study singularities of ruled surfaces in  $\mathbb{R}^3$ . The main result asserts that only cross-caps appear as singularities for generic ruled surfaces.

## 1 Introduction

The ruled surfaces in  $\mathbb{R}^3$  is a classical subject in differential geometry. It is, however, paid attention in some areas again (i.e., Projective differential geometry [16], Computer aided design [7,18] etc.) Generally ruled surfaces have singularities. Recently there appeared several articles concerning on singularities of developable surfaces in  $\mathbb{R}^3$  (cf., [3,8,9,10,11,12,14,15,17]). The developable surface is a surface with the vanishing Gaussian curvature on the regular part and it is also a ruled surface. In these articles classifications of singularities of developable surfaces are given. Briefly speaking, the cuspidal edge, the cuspidal cross cap or the swallowtail appear as singularities of developable surfaces in generic (cf., Fig. 1).

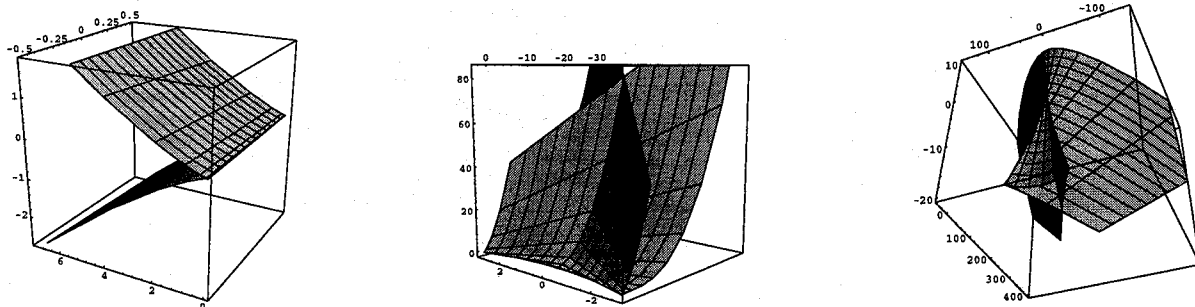

Fig. 1

---

1991 Mathematics Subject classification. 58C27, 53A25, 53A05

Key Words and Phrases. ruled surfaces, developable surfaces, singularities

On the other hand, the Gaussian curvature of the regular part of a ruled surface is generally nonpositive. So the developable surface is a member of the special class of ruled surfaces. Therefore we have the following natural question:

**Question.** How are singularities of developable surfaces different from those of “general” ruled surfaces?

In this paper we give a classification of singularities of general ruled surface. A ruled surface in  $\mathbb{R}^3$  is (locally) the image of the map  $F_{(\gamma,\delta)} : I \times J \rightarrow \mathbb{R}^3$  defined by  $F_{(\gamma,\delta)}(t, u) = \gamma(t) + u\delta(t)$ , where  $\gamma : I \rightarrow \mathbb{R}^3$ ,  $\delta : I \rightarrow S^2$  are smooth mappings and  $I, J$  are open intervals. We assume that  $I$  is bounded. We call  $\gamma$  a base curve and  $\delta$  a director curve. The straightlines  $u \mapsto \gamma(t) + u\delta(t)$  are called *rulings*.

In order to describe the main result in this paper we need some preparations. Let  $f_i : (N_i, x_i) \rightarrow (P_i, y_i)$  ( $i = 1, 2$ ) be  $C^\infty$  map germs. We say that  $f, g$  are  $\mathcal{A}$ -equivalent if there exist diffeomorphism germs  $\phi : (N_1, x_1) \rightarrow (N_2, x_2)$  and  $\psi : (P_1, y_1) \rightarrow (P_2, y_2)$  such that  $\psi \circ f_1 = f_2 \circ \phi$ . Let  $C_{pr}^\infty(I, \mathbb{R}^3 \times S^2)$  be the space of smooth proper mappings  $(\gamma, \delta) : I \rightarrow \mathbb{R}^3 \times S^2$  equipped with Whitney  $C^\infty$ -topology, where  $I$  is an open interval. The following theorem is the main result in this paper which gives a “generic” answer to the above question.

**Theorem 1.1** *There exists an open dense subset  $\mathcal{O} \subset C_{pr}^\infty(I, \mathbb{R}^3 \times S^2)$  such that the germ of the ruled surface  $F_{(\gamma,\delta)}$  at any point  $(t_0, u_0)$  is an immersion germ or  $\mathcal{A}$ -equivalent to the cross cap for any  $(\gamma, \delta) \in \mathcal{O}$ .*

Here, the cross cap is the map germ defined by  $(x_1, x_2) \mapsto (x_1^2, x_2, x_1x_2)$ .

It is well known that any singular point for generic smooth mappings from a surface to  $\mathbb{R}^3$  is the cross cap (cf., [1,5,13,19]). The set of ruled surfaces is a very small subset in the space of all  $C^\infty$ -mappings. The above theorem, however, asserts that the generic singularities of ruled surfaces are the same as those of  $C^\infty$ -mappings. We remark that the cross cap is realized as a singularity of a ruled surface as follows: Consider curves  $\gamma(t) = (t^2, 0, 0)$  and  $\delta(t) = \left(0, \frac{1}{\sqrt{1+t^2}}, \frac{t}{\sqrt{1+t^2}}\right)$ , then  $F_{(\gamma,\delta)}(t, u)$  is the cross cap (cf., Fig. 2) which corresponds to the normal form.

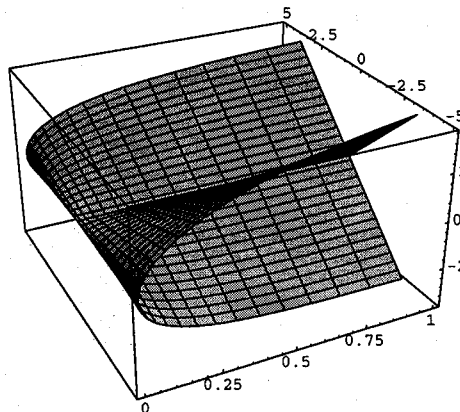

Fig. 2

We can summarize the results of the above theorem as the following relations by referring the previous results[3,10,11,12,15] :

$$\{\text{Singularities of generic developable surfaces}\} \neq \{\text{Singularities of generic ruled surfaces}\},$$

$$\{\text{Singularities of generic ruled surfaces}\} = \{\text{Singularities of generic } C^\infty\text{-mappings}\}.$$

One of the examples of ruled surfaces with cross caps is *the Plücker's conoid* which is given by  $\gamma(\theta) = (0, 0, 2 \cos \theta \sin \theta)$  and  $\delta(\theta) = (\cos \theta, \sin \theta, 0)$  ( $0 \leq \theta \leq 2\pi$ ) (cf., Fig. 3).

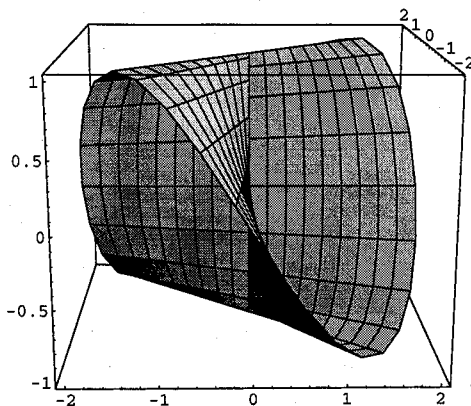

Fig. 3

We can also see a beautiful picture of the ruled surface at the home page of T. Banchoff[2].

In §2 we briefly review the classical theory of ruled surfaces. The idea of the proof of Theorem 1.1 is that we may locally regard the ruled surface as a one-dimensional unfolding of a map germ and apply the theory of unfoldings. In this case the parameter along rulings is considered to be the unfolding parameter. In §3 we prepare the general theory of unfoldings. The proof of Theorem 1.1 is given in §4.

This is the first paper of the authors joint project entitled “Geometry of ruled surfaces and line congruences”.

All manifolds and maps considered here are of class  $C^\infty$  unless otherwise stated.

## 2 Basic notions and a review of the classical theory

We now present basic concepts and properties of ruled surfaces in  $\mathbb{R}^3$ . The classical theory has been given in [6]. However, these are not so popular now, so that we review the classical framework. For the ruled surface  $F_{(\gamma,\delta)}$ , if  $\delta$  is a constant vector  $v$ , then the ruled surface  $F_{(\gamma,v)}$  is a generalized cylinder. Therefore, the ruled surface  $F_{(\gamma,\delta)}$  is said to be *noncylindrical* provided  $\delta'$  never vanishes. Thus the rulings are always changing directions on a noncylindrical ruled surface. It is clear that the set  $\mathcal{O}^1$  consisting of noncylindrical ruled surfaces is an open and dense subset in  $C_{pr}^\infty(I, \mathbb{R}^3 \times S^2)$ . Then we have the following lemma (cf., [6] Lemmas 17.7,17.8).

**Lemma 2.1** (1) *Let  $F_{(\gamma,\delta)}(t, u)$  be a noncylindrical ruled surface. Then there exists a smooth curve  $\sigma : I \rightarrow \mathbb{R}^3$  such that  $\text{Image } F_{(\gamma,\delta)} = \text{Image } F_{(\sigma,\delta)}$  and  $\langle \sigma'(t), \delta'(t) \rangle = 0$ , where  $\langle, \rangle$*

denotes the canonical inner product on  $\mathbb{R}^3$ . The curve  $\sigma(t)$  is called the striction curve of  $F_{(\gamma,\delta)}(t, u)$ .

(2) The striction curve of a noncylindrical ruled surface  $F_{(\gamma,\delta)}(t, u)$  does not depend on the choice of the base curve  $\gamma$ .

We can specify the place where the singularities of the ruled surface are located.

**Lemma 2.2** Let  $F_{(\sigma,\delta)}$  be a ruled surface with the striction curve  $\sigma$ . If  $x_0 = F_{(\sigma,\delta)}(t_0, u_0)$  is a singular point of the ruled surface  $F_{(\sigma,\delta)}$  then  $u_0 = 0$  (i.e.,  $x_0 \in \text{Image } \sigma$ ). Moreover, if  $\sigma'(t_0) \neq 0$ , then the ruling through  $\sigma(t_0)$  is tangent to  $\sigma$  at  $t_0$ .

*Proof.* We can calculate the partial derivative of  $F_{(\sigma,\delta)}$  as follows:

$$\frac{\partial F_{(\sigma,\delta)}}{\partial t}(t, u) = \sigma'(t) + u\delta'(t), \quad \frac{\partial F_{(\sigma,\delta)}}{\partial u}(t, u) = \delta(t).$$

Therefore we have

$$\frac{\partial F_{(\sigma,\delta)}}{\partial t} \times \frac{\partial F_{(\sigma,\delta)}}{\partial u}(t, u) = \sigma'(t) \times \delta(t) + u\delta'(t) \times \delta(t),$$

where  $\times$  denotes the exterior product in  $\mathbb{R}^3$ . Since  $\|\delta(t)\| = \sqrt{\langle \delta(t), \delta(t) \rangle} \equiv 1$ , we have  $\langle \delta'(t), \delta(t) \rangle \equiv 0$ . By the condition that  $\langle \sigma'(t), \delta'(t) \rangle \equiv 0$  and the above, there exists a smooth function  $\lambda(t)$  such that  $\sigma'(t) \times \delta(t) = \lambda(t)\delta'(t)$ . So we have

$$\begin{aligned} \left\| \frac{\partial F_{(\sigma,\delta)}}{\partial t} \times \frac{\partial F_{(\sigma,\delta)}}{\partial u}(t, u) \right\|^2 &= \|\lambda(t)\delta'(t) + u\delta'(t) \times \delta(t)\|^2 \\ &= \lambda(t)^2 \|\delta'(t)\|^2 + 2\lambda(t)u \langle \delta'(t), \delta'(t) \times \delta(t) \rangle + u^2 \|\delta'(t) \times \delta(t)\|^2 \\ &= (\lambda(t)^2 + u^2) \|\delta'(t)\|^2. \end{aligned}$$

Suppose that  $x_0 = F_{(\sigma,\delta)}(t_0, u_0)$  is a singular point of the ruled surface  $F_{(\sigma,\delta)}$ , then

$$\left\| \frac{\partial F_{(\sigma,\delta)}}{\partial t} \times \frac{\partial F_{(\sigma,\delta)}}{\partial u}(t_0, u_0) \right\| = 0.$$

Since  $F_{(\sigma,\delta)}$  is noncylindrical, this means that  $u_0 = \lambda(t_0) = 0$ . □

By Lemma 2.2, the singularities of a ruled surface are located on the striction curve. If we consider the cross cap  $F_{(\gamma,\delta)}(t, u) = \left( t^2, \frac{u}{\sqrt{1+t^2}}, \frac{ut}{\sqrt{1+t^2}} \right)$ , then  $\gamma'(t) = (2t, 0, 0)$  and  $\delta'(t) = \left( 0, \frac{-t}{\sqrt{(1+t^2)^3}}, \frac{1}{\sqrt{(1+t^2)^3}} \right)$ . By definition,  $\gamma(t)$  is the striction curve of  $F_{(\gamma,\delta)}(t, u)$  and the singular point is  $(0, 0, 0)$ .

We also consider the following examples.

**Example 2.3** We now consider curves  $\gamma : I \rightarrow \mathbb{R}^3$  and  $\delta : I \rightarrow S^2$  given by  $\gamma(t) = (0, 0, f(t))$  and  $\delta(t) = (\cos t, \sin t, 0)$ . Then the ruled surface  $F_{(\gamma,\delta)}(t, u) = (u \cos t, u \sin t, f(t))$  is called a *positive conoid*. We can easily calculate that singularities of  $F_{(\gamma,\delta)}(t, u)$  is given by  $u = 0$ ,  $f'(t) = 0$  and the striction curve is  $\gamma(t)$ .

On the other hand, let  $g : (\mathbb{R}^2, 0) \rightarrow (\mathbb{R}^3, 0)$  be a smooth map germ. It has been known that the origin is the cross cap if and only if there exists a local chart  $(x_1, x_2)$  around the origin such that the following conditions hold:

$$\frac{\partial g}{\partial x_1}(0) \neq 0, \quad \frac{\partial g}{\partial x_2}(0) = 0 \quad \text{and} \quad \det \left( \frac{\partial g}{\partial x_1}(0), \frac{\partial^2 g}{\partial x_1 \partial x_2}(0), \frac{\partial^2 g}{\partial x_2^2}(0) \right) \neq 0.$$

By a direct calculation,  $F_{(\gamma, \delta)}(t_0, 0)$  is the cross cap if and only if  $f'(t_0) = 0$  and  $f''(t_0) \neq 0$ . The above condition means that  $t_0$  is a Morse singular point of  $f(t)$ . Moreover, it is well-known that Morse functions are generic in the space of smooth functions. Therefore, this example certifies the assertion of the main theorem. One of the examples of positive conoids with cross caps is the Plücker's conoid which has been given in §1 (cf., Fig. 3).

**Example 2.4** Consider the developable surface

$$F_{(\gamma, \delta)}(t, u) = \left( u, -2t^2 - \frac{3}{2}tu, t^4 + \frac{1}{2}t^3u \right)$$

with the cuspidal cross cap. If we slightly perturb it into the ruled surface

$$F_{(\gamma, \delta)}^\varepsilon(t, u) = \left( u, -2t^2 - \frac{3}{2}tu, t^4 + \varepsilon t^2 + \frac{1}{2}t^3u \right),$$

we can easily show that the origin is the cross cap. The situation is depicted in Fig.4. The left picture is  $F_{(\gamma, \delta)}(t, u)$  and the right one is  $F_{(\gamma, \delta)}^{0.2}(t, u)$ .

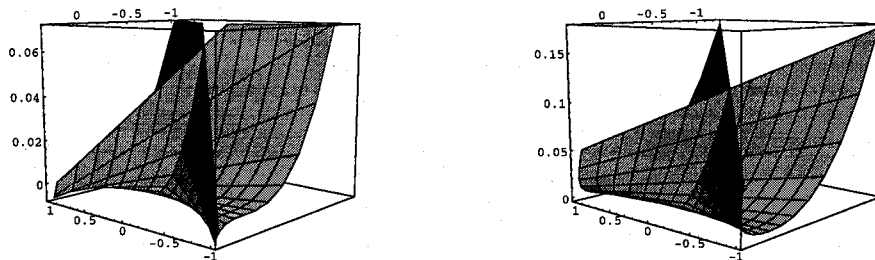

Fig. 4

### 3 Unfoldings

For the proof of Theorem 1.1, we need to prepare and review the theory of one-dimensional unfoldings of map germs. The definition of  $r$ -dimensional unfolding of  $f_0 : (\mathbb{R}^n, 0) \rightarrow (\mathbb{R}^p, 0)$  (originally due to Thom) is a germ  $F : (\mathbb{R}^n \times \mathbb{R}^r, 0) \rightarrow (\mathbb{R}^p \times \mathbb{R}^r, 0)$  given by  $F(x, u) = (f(x, u), u)$ , where  $f(x, u)$  is a germ of  $r$  dimensional parameterized families of germs with  $f(x, 0) = f_0(x)$ . This definition depends on the coordinates of both of spaces  $(\mathbb{R}^n \times \mathbb{R}^r, 0)$  and  $(\mathbb{R}^p \times \mathbb{R}^r, 0)$ . For our purpose, we need the coordinate free definition of unfoldings [4]. Let  $f : (N, x_0) \rightarrow (P, y_0)$  be a map-germ between manifolds. An *unfolding* of  $f$  is a triple  $(F, i, j)$  of map germs, where  $i : (N, x_0) \rightarrow (N', x'_0)$ ,  $j : (P, y_0) \rightarrow (P', y'_0)$  are immersions and  $j$  is transverse to  $F$ , such that  $F \circ i = j \circ f$  and  $(i, f) : \{(x', y) \in N' \times P \mid F(x') = j(y)\} \rightarrow N$  is a diffeomorphism germ. The *dimension* of  $(F, i, j)$  as an unfolding is  $\dim N' - \dim N$ . We can easily prove that the above two definitions are equivalent.

**Lemma 3.1** Let  $F : (\mathbb{R}^2, 0) \rightarrow (\mathbb{R}^3, 0)$  be a map germ with the components of the form  $F(t, u) = (F_1(t, u), F_2(t, u), F_3(t, u))$ . Suppose that  $\frac{\partial F_3}{\partial u}(0, 0) \neq 0$ . By the implicit function theorem, there exists a function germ  $g : (\mathbb{R}, 0) \rightarrow (\mathbb{R}, 0)$  with  $F^{-1}(0) = \{(t, g(t)) \mid t \in (\mathbb{R}, 0)\}$ . Let us consider immersion germs  $i : (\mathbb{R}, 0) \rightarrow (\mathbb{R}^2, 0)$  given by  $i(t) = (t, g(t))$ ,  $j : (\mathbb{R}^2, 0) \rightarrow (\mathbb{R}^3, 0)$  given by  $j(y_1, y_2) = (y_1, y_2, 0)$  and a map germ  $f : (\mathbb{R}, 0) \rightarrow (\mathbb{R}^2, 0)$  given by  $f(t) = (F_1(t, g(t)), F_2(t, g(t)))$ . Then the triple  $(F, i, j)$  is a one-dimensional unfolding of  $f$ .

*Proof.* It is clear that  $F \circ i = j \circ f$ . Since  $\frac{\partial F_3}{\partial u}(0, 0) \neq 0$ ,  $F$  is transverse to  $j$ . We can easily show that

$$\{(t, u, y_1, y_2) \mid F(t, u) = j(y_1, y_2)\} = \{(t, g(t), F_1(t, g(t)), F_2(t, g(t))) \mid t \in (\mathbb{R}, 0)\}.$$

Since  $(i, f) : (\mathbb{R}, 0) \rightarrow (\mathbb{R}^2 \times \mathbb{R}^2, 0)$  is given by  $(i, f)(t) = (t, g(t), F_1(t, g(t)), F_2(t, g(t)))$ , it maps diffeomorphically on to the above set. This completes the proof.  $\square$

Since the cross cap is a stable singularity of map germs  $(\mathbb{R}^2, 0) \rightarrow (\mathbb{R}^3, 0)$ , we now discuss the stability of unfoldings. Let  $\mathcal{E}_n$  be the local ring of function germs  $(\mathbb{R}^n, 0) \rightarrow \mathbb{R}$  and the unique maximal ideal is denoted by  $\mathcal{M}_n$ . For a map germ  $f : (\mathbb{R}^n, 0) \rightarrow (\mathbb{R}^p, 0)$ , we say that  $f$  is *infinitesimally  $\mathcal{A}$ -stable* if the following equality holds:

$$\mathcal{E}(n, p) = \left\langle \frac{\partial f}{\partial x_1}, \dots, \frac{\partial f}{\partial x_n} \right\rangle_{\mathcal{E}_n} + f^* \mathcal{E}(p, p),$$

where  $\mathcal{E}(n, p)$  denotes the  $\mathcal{E}_n$ -module of map germs  $(\mathbb{R}^n, 0) \rightarrow (\mathbb{R}^p, 0)$  and  $f^* : \mathcal{E}(p, p) \rightarrow \mathcal{E}(n, p)$  is the *pull back map* given by  $f^*(h) = h \circ f$ . It has been known that an infinitesimally  $\mathcal{A}$ -stable map germ  $(\mathbb{R}^2, 0) \rightarrow (\mathbb{R}^3, 0)$  is an immersion germ or the cross cap [1,5,13,19].

For map germs  $f, g : (\mathbb{R}^n, 0) \rightarrow (\mathbb{R}^p, 0)$ , we say that they are  $\mathcal{K}$ -equivalent if there exists a diffeomorphism germ  $\phi : (\mathbb{R}^n, 0) \rightarrow (\mathbb{R}^n, 0)$  such that  $f^*(\mathcal{M}_p)\mathcal{E}_n = \phi^* \circ g^*(\mathcal{M}_p)\mathcal{E}_n$ . The  $\mathcal{K}$ -equivalence is a equivalence relation among map germs. Let  $J^k(n, p)$  be the *k-jet space* of map germ  $(\mathbb{R}^n, 0) \rightarrow (\mathbb{R}^p, 0)$ . For any  $z = j^k f(0) \in J^k(n, p)$ , we denote that

$$\mathcal{K}^k(z) = \{j^k g(0) \mid g \text{ is } \mathcal{K}\text{-equivalent to } f\}.$$

We call it a  *$\mathcal{K}^k$ -orbit* since it is the orbit of a certain Lie group action. For any map germ  $f : (\mathbb{R}^n \times \mathbb{R}^r, 0) \rightarrow (\mathbb{R}^p, 0)$ , we define a map germ  $j_1^k f : (\mathbb{R}^n \times \mathbb{R}^r, 0) \rightarrow J^k(n, p)$  by  $j_1^k f(x_0, u_0) = j^k f_{u_0}(x_0)$ , where  $f_u(x) = f(x, u)$  and  $j^k f_{u_0}(x_0) = j^k(f_{u_0}(x + x_0))(0)$ . We have the following Lemma (cf., [13]).

**Lemma 3.2** Under the same notations as the above,  $j_1^k f$  is transverse to  $\mathcal{K}^k(j_1^k f_0(0))$  if and only if

$$\mathcal{E}(n, p) = \left\langle \frac{\partial f_0}{\partial x_1}, \dots, \frac{\partial f_0}{\partial x_n} \right\rangle_{\mathcal{E}_n} + f_0^*(\mathcal{M}_p)\mathcal{E}(n, p) + \left\langle \frac{\partial f}{\partial u_1}(x, 0), \dots, \frac{\partial f}{\partial u_r}(x, 0), e_1, \dots, e_p \right\rangle_{\mathbb{R}},$$

where  $e_i$  ( $i = 1, \dots, p$ ) is the canonical basis of  $\mathbb{R}^p$ .

The following lemma is implicitly well-known. However, we cannot find any context on where the proof is explicitly written. So we give the proof here.



**Lemma 3.3** Let  $F : (\mathbb{R}^n \times \mathbb{R}^r, 0) \longrightarrow (\mathbb{R}^p \times \mathbb{R}^r, 0)$  be an unfolding of  $f_0$  of the form  $F(x, u) = (f(x, u), u)$ . If  $j_1^k f$  is transverse to  $\mathcal{K}^k(j^k f_0(0))$  for sufficiently large  $k$ , then  $F$  is infinitesimally  $A$ -stable.

*Proof.* By Lemma 3.2 we may assume that

$$\mathcal{E}(n, p) = \left\langle \frac{\partial f_0}{\partial x_1}, \dots, \frac{\partial f_0}{\partial x_n} \right\rangle_{\mathcal{E}_n} + f_0^*(\mathcal{M}_p)\mathcal{E}(n, p) + \left\langle \frac{\partial f}{\partial u_1}(x, 0), \dots, \frac{\partial f}{\partial u_r}(x, 0), e_1, \dots, e_p \right\rangle_{\mathbb{R}}.$$

We can show that

$$\begin{aligned} \mathcal{E}(n+r, p) &= \left\langle \frac{\partial f_0}{\partial x_1}, \dots, \frac{\partial f_0}{\partial x_n} \right\rangle_{\mathcal{E}_{n+r}} + f_0^*(\mathcal{M}_p)\mathcal{E}(n+r, p) \\ &\quad + \left\langle \frac{\partial f}{\partial u_1}(x, 0), \dots, \frac{\partial f}{\partial u_r}(x, 0), e_1, \dots, e_p \right\rangle_{\mathcal{E}_r} + \mathcal{M}_r\mathcal{E}(n+r, p). \end{aligned}$$

By the Malgrange preparation theorem (cf., [4,5,13]), we have

$$\begin{aligned} \mathcal{E}(n+r, p) &= \left\langle \frac{\partial f_0}{\partial x_1}, \dots, \frac{\partial f_0}{\partial x_n} \right\rangle_{\mathcal{E}_{n+r}} + f_0^*(\mathcal{M}_p)\mathcal{E}(n+r, p) \\ &\quad + \left\langle \frac{\partial f}{\partial u_1}(x, 0), \dots, \frac{\partial f}{\partial u_r}(x, 0), e_1, \dots, e_p \right\rangle_{\mathcal{E}_r}. \end{aligned}$$

For any  $\xi = (\xi_1, \xi_2) \in \mathcal{E}(n+r, p+r) = \mathcal{E}(n+r, p) \times \mathcal{E}(n+r, r)$ , there exist  $\lambda_i, \eta_i \in \mathcal{E}_{n+r}$  and  $\mu_i, \zeta_i \in \mathcal{E}_r$  such that

$$\xi_1 = \sum_{i=1}^n \lambda_i \frac{\partial f_0}{\partial x_i} + \sum_{i=1}^p \eta_i f_{0,i} + \sum_{i=1}^r \mu_i \frac{\partial f_0}{\partial u_i} + \sum_{i=1}^p \zeta_i e_i.$$

Therefore, we have

$$\begin{aligned} (\xi_1, 0) &= \sum_{i=1}^n \lambda_i \frac{\partial F}{\partial x_i} + \sum_{i=1}^p \eta_i (f_i, 0) + \sum_{i=1}^r \mu_i \left( \frac{\partial f}{\partial u_i}, 0 \right) + \sum_{i=1}^p \zeta_i (e_i, 0) \\ &= \sum_{i=1}^n \lambda_i \frac{\partial F}{\partial x_i} + \sum_{i=1}^r \mu_i \frac{\partial F}{\partial u_i} + \sum_{i=1}^p \eta_i (f_i, 0) + \sum_{i=1}^p (\zeta_i - \mu_i) (e_i, 0). \end{aligned}$$

Since  $\zeta_i - \mu_i \in \mathcal{E}_r$ ,  $\sum_{i=1}^p (\zeta_i - \mu_i) (e_i, 0) \in F^*\mathcal{E}(p+r, p+r)$ . This means that

$$(\xi_1, 0) \in \left\langle \frac{\partial F}{\partial x_1}, \dots, \frac{\partial F}{\partial x_n}, \frac{\partial F}{\partial u_1}, \dots, \frac{\partial F}{\partial u_r} \right\rangle_{\mathcal{E}_{n+r}} + F^*\mathcal{E}(p+r, p+r) + F^*(\mathcal{M}_{p+r})\mathcal{E}(n+r, p+r).$$

On the other hand, we have

$$(0, \xi_2) = \sum_{i=1}^r \xi_{2,i} \frac{\partial F}{\partial u_i} - \sum_{i=1}^r \xi_{2,i} \left( \frac{\partial f}{\partial u_i}, 0 \right).$$

By the same arguments those of the above, we have

$$(0, \xi_2) \in \left\langle \frac{\partial F}{\partial x_1}, \dots, \frac{\partial F}{\partial x_n}, \frac{\partial F}{\partial u_1}, \dots, \frac{\partial F}{\partial u_r} \right\rangle_{\mathcal{E}_{n+r}} + F^*\mathcal{E}(p+r, p+r) + F^*(\mathcal{M}_{p+r})\mathcal{E}(n+r, p+r).$$

Hence, we have

$$\begin{aligned} \mathcal{E}(n+r, p+r) &= \left\langle \frac{\partial F}{\partial x_1}, \dots, \frac{\partial F}{\partial x_n}, \frac{\partial F}{\partial u_1}, \dots, \frac{\partial F}{\partial u_r} \right\rangle_{\mathcal{E}_{n+r}} \\ &\quad + F^* \mathcal{E}(p+r, p+r) + F^*(\mathcal{M}_{p+r}) \mathcal{E}(n+r, p+r). \end{aligned}$$

Applying the Malgrange preparation theorem once again, we have

$$\mathcal{E}(n+r, p+r) = \left\langle \frac{\partial F}{\partial x_1}, \dots, \frac{\partial F}{\partial x_n}, \frac{\partial F}{\partial u_1}, \dots, \frac{\partial F}{\partial u_r} \right\rangle_{\mathcal{E}_{n+r}} + F^* \mathcal{E}(p+r, p+r).$$

□

## 4 Generic classifications

In this section we give the proof of Theorem 1.1. Since the infinitesimally  $\mathcal{A}$ -stable map germ  $(\mathbb{R}^2, 0) \longrightarrow (\mathbb{R}^3, 0)$  is an immersion or the cross cap, we now prove that the germ of the ruled surface  $F_{(\gamma, \delta)}$  at any point is infinitesimally  $\mathcal{A}$ -stable for generic  $(\gamma, \delta)$ .

On the other hand, by the calculation of the proof of Lemma 2.2, the singular point of the ruled surface  $F_{(\gamma, \delta)}$  is given by the condition that  $\text{rank}(\gamma'(t) + u\delta'(t), \delta(t)) < 2$  and it is equivalent to the condition that two vectors  $\gamma'(t) + u\delta'(t)$ ,  $\delta(t)$  are parallel. Since  $\delta(t) \neq 0$ ,  $\text{rank}(\gamma'(t) + u\delta'(t), \delta(t)) \geq 1$ .

We now regard the parameter  $u$  (i.e., the parameter along the ruling) of the ruled surface as the parameter of a one-dimensional unfolding. For any  $(\gamma, \delta) : I \longrightarrow \mathbb{R}^3 \times S^2$  with  $\delta'(t) \neq 0$ , we denote that  $\gamma(t) = (\gamma_1(t), \gamma_2(t), \gamma_3(t))$  and  $\delta(t) = (\delta_1(t), \delta_2(t), \delta_3(t))$ , then we have the coordinate representation:

$$F_{(\gamma, \delta)}(t, u) = (\gamma_1(t) + u\delta_1(t), \gamma_2(t) + u\delta_2(t), \gamma_3(t) + u\delta_3(t)).$$

For any fixed  $(t_0, u_0) \in I \times J$  with  $\delta_3(t_0) \neq 0$ , we define a non empty open subset  $U_3$  in  $I$  by

$$U_3 = \{t \in I \mid \delta_3(t) \neq 0\}.$$

We define a function  $g_3(t)$  by  $g_3(t) = -\frac{\gamma_3(t) - y_0}{\delta_3(t)}$  for any  $t \in U_3$ , where  $y_0 = \gamma_3(t_0) + u_0\delta_3(t_0)$ .

Therefore, we have

$$F_{(\gamma, \delta)}(t, u) = \gamma(t) + g_3(t)\delta(t) + (u - g_3(t))\delta(t) = \gamma(T) + g_3(T)\delta(T) + U\delta(T)$$

for  $T = t$ ,  $U = u - g_3(t)$ . We denote the above map as  $\tilde{F}_{(\gamma, \delta)}(T, U)$ . By Lemma 3.1, the map germ  $\tilde{F}_{(\gamma, \delta)}(T, U)$  at  $(t_0, 0)$  is a one-dimensional unfolding of  $\hat{\pi}_3 \circ \tilde{F}_{(\gamma, \delta)}(T, 0) = (\gamma_1(T) + g_3(T)\delta_1(T), \gamma_2(T) + g_3(T)\delta_2(T))$ , where  $\hat{\pi}_3 : \mathbb{R}^3 \longrightarrow \mathbb{R}^2$  is the canonical projection given by  $\hat{\pi}_3(y_1, y_2, y_3) = (y_1, y_2)$ . The following lemma is the basis for the proof of Theorem 1.1.

**Lemma 4.1** *Let  $W \subset J^k(1,2)$  be a submanifold. For any fixed map germ  $\delta : I \longrightarrow S^2$  with  $\delta'(t) \neq 0$  and any fixed point  $(t_0, u_0) \in I \times J$  with  $\delta_3(t_0) \neq 0$ , the set*

$${}_3T_{W, (t_0, u_0)} = \{\gamma \mid j_1^k \hat{\pi}_3 \circ \tilde{F}_{(\gamma, \delta)} \text{ is transverse to } W \text{ at } (t_0, u_0)\}$$

*is a residual subset in  $C^\infty(I, \mathbb{R}^3) \times \{\delta\}$ .*

*Here, we consider that  $C^\infty(I, \mathbb{R}^3 \times S^2) = C^\infty(I, \mathbb{R}^3) \times C^\infty(I, S^2)$  and relative topology on  $C^\infty(I, \mathbb{R}^3) \times \{\delta\}$ .*

For the proof of Lemma 4.1, we need the following Thom's fundamental transversality lemma (cf., [5]) like as usual.

**Lemma 4.2** *Let  $X, B$  and  $Y$  be  $C^\infty$ -manifolds with  $W$  a submanifold of  $Y$ . Let  $j : B \rightarrow C^\infty(X, Y)$  be a mapping (not necessarily continuous) and define  $\Phi : X \times B \rightarrow Y$  by  $\Phi(x, b) = j(b)(x)$ . Assume that  $\Phi$  is smooth and transverse to  $W$ . Then the set*

$$\{b \in B \mid j(b) \text{ is transverse to } W\}$$

is dense in  $B$ .

*Proof of Lemma 4.1.* Let  $\{K_j\}_{j=1}^\infty$  be the countable set of open covering of  $W$  such that each closure  $\bar{K}_j$  is compact. We define the following set

$${}_3T_{W,(t_0,u_0),K_j} = \left\{ \gamma \mid j_1^k \hat{\pi}_3 \circ \tilde{F}_{(\gamma,\delta)} \text{ is transverse to } W \right. \\ \left. \text{with } j_1^k \hat{\pi}_3 \circ \tilde{F}_{(\gamma,\delta)}(t_0, u_0) \in \bar{K}_j \right\}.$$

We now prove that  ${}_3T_{W,(t_0,u_0),K_j}$  is an open subset. For the purpose, we consider the following mapping

$$\hat{j}^k : C^\infty(U_3, \mathbb{R}^3) \rightarrow C^\infty(U_3 \times J, J^k(1, 2))$$

defined by  $\hat{j}^k(\gamma) = j^k \hat{\pi}_3 \circ \tilde{F}_{(\gamma,\delta)}$ . It is clear that the mapping  $\hat{j}^k$  is continuous. We also define a subset

$$O_{W,K_j} = \{g \in C^\infty(U_3 \times J, J^k(1, 2)) \mid g \text{ is transverse to } W \text{ at } (t_0, u_0) \text{ with } g(t_0, u_0) \in K_j\},$$

then it is open (cf., [5]). Since the restriction map  $res_{U_3} : C^\infty(I, \mathbb{R}^3) \rightarrow C^\infty(U_3, \mathbb{R}^3)$  is continuous,  ${}_3T_{W,(t_0,u_0),K_j} = (res_{U_3})^{-1} \circ (\hat{j}^k)^{-1}(O_{W,K_j})$  is open. If we show that  ${}_3T_{W,(t_0,u_0),K_j}$  is dense subset in  $C^\infty(I, \mathbb{R}^3) \times \{\delta\}$ , then  $T_{W,(t_0,u_0)} = \bigcap_{j=1}^\infty {}_3T_{W,(t_0,u_0),K_j}$  is a residual subset.

Since  $res_{U_3}$  is surjective, it is enough to show that

$$T_{W,(t_0,u_0),K_j,U_3} = \left\{ \gamma \in C^\infty(U_3, \mathbb{R}^3) \mid j_1^k \hat{\pi}_3 \circ \tilde{F}_{(\gamma,\delta)} \text{ is transverse to } W \text{ at } (t_0, u_0) \right. \\ \left. \text{with } j_1^k \hat{\pi}_3 \circ \tilde{F}_{(\gamma,\delta)}(t_0, u_0) \in \bar{K}_j \right\}.$$

is a dense subset in  $C^\infty(U_3, \mathbb{R}^3)$ .

For any  $\gamma \in C^\infty(U_3, \mathbb{R}^3)$  and  $p = (p_1, p_2) \in P(1, 2; k)$ , we define a mapping  $f_{(\gamma,p)} : U_3 \times J \rightarrow \mathbb{R}^2$  by

$$f_{(\gamma,p)}(t, u) = (\gamma_1(t) + p_1(t) + g_3(t)\delta_1(t) + u\delta_1(t), \gamma_2(t) + p_2(t) + g_3(t)\delta_2(t) + u\delta_2(t)),$$

where  $P(1, 2; k)$  denote the space of the pair of polynomials  $(p_1, p_2)$  with degrees are at most  $k$  without constant terms. We also define a mapping  $\Phi : U_3 \times J \times P(1, 2; k) \rightarrow J^k(1, 2)$  by  $\Phi(t, u, (p_1, p_2)) = j_1^k f_{(\gamma,p)}(t, u) = j^k f_{(\gamma,p),u}(t)$ , where  $f_{(\gamma,p),u}(t) = f_{(\gamma,p)}(t, u)$ . We may regard that  $P(1, 2; k)$  is Euclidian space  $\mathbb{R}^N$ .

It is easy to show that  $\Phi$  is a submersion, so that it is transverse to  $W$ . By Lemma 4.2,

$$\{p = (p_1, p_2) \in P(1, 2; k) \mid \Phi_{(p_1,p_2)} \text{ is transverse to } W \text{ at } (t_0, u_0) \text{ with } \Phi_{(p_1,p_2)}(t_0, u_0) \in \bar{K}_j\}$$

is dense in  $P(1, 2, ; k)$ . Hence, we can find  $(p_1, p_2)_1, (p_1, p_2)_2, (p_1, p_2)_3, \dots$  in  $P(1, 2; k)$  converging to  $(0, 0)$  so that  $\Phi_{(p_1, p_2)_i}$  is transverse to  $W$  on  $K_j$ . Since  $\lim_{i \rightarrow \infty} (\gamma + ((p_1, p_2)_i, 0)) = \gamma$  in  $C^\infty(U_3, \mathbb{R}^3)$ ,  $T_{W, (t_0, u_0), K_j, U_3}$  is dense in  $C^\infty(U_3, \mathbb{R}^3)$ .  $\square$

We remark that  ${}_j T_{W, (t_0, u_0)}$  ( $j = 1, 2$ ) can also be defined for  $(t_0, u_0) \in I \times J$  with  $\delta_j(t_0) \neq 0$  and the same assertion for  ${}_j T_{W, (t_0, u_0)}$  as the above holds.

*Proof of Theorem 1.1.* Let  $\mathcal{K}_i$  be the  $\mathcal{K}$ -orbit with codimension  $i$  in  $J^k(1, 2)$  for sufficiently large  $k$ . We also denote that  $\Sigma(1, 2) = \bigcap_{i \geq 3} \mathcal{K}_i \subset J^k(1, 2)$ . It has been known that  $\Sigma(1, 2)$  is a semi-algebraic subset in  $J^k(1, 2)$  with codimension greater than 2. Therefore we have the canonical stratification  $\{\mathcal{S}_i\}_{i=1}^m$  of  $\Sigma(1, 2)$  with  $\text{codim } \mathcal{S}_i > 2$ . For any  $(t_0, u_0)$  with  $\delta_3(t_0) \neq 0$ , we denote that  ${}_3 T_{\Sigma(1, 2), (t_0, u_0)} = \bigcap_{i=1}^m {}_3 T_{\mathcal{S}_i, (t_0, u_0)}$ . Since  ${}_3 T_{\mathcal{K}_i, (t_0, u_0)}$  and  ${}_3 T_{\Sigma(1, 2), (t_0, u_0)}$  are residual subsets in  $C_{pr}^\infty(I, \mathbb{R}^3 \times S^2)$ ,  ${}_3 \mathcal{O}_{(t_0, u_0)} = \bigcap_{i=1}^2 {}_3 T_{\mathcal{K}_i, (t_0, u_0)} \cap T_{\Sigma(1, 2), (t_0, u_0)}$  is also a residual subset in

$C_{pr}^\infty(I, \mathbb{R}^3 \times S^2)$ . By the remark after the proof of Lemma 4.1,  ${}_j \mathcal{O}_{(t_0, u_0)}$  ( $j = 1, 2$ ) are also residual subsets in  $C_{pr}^\infty(I, \mathbb{R}^3 \times S^2)$  respectively. Therefore, for any fixed  $(t_0, u_0) \in I \times J$ , there exists a residual subset  $\mathcal{O}_{(t_0, u_0)} \subset C_{pr}^\infty(I, \mathbb{R}^3 \times S^2)$  such that the map germ  $F_{(\gamma, \delta)}$  at  $(t_0, u_0)$  is an infinitesimally  $\mathcal{A}$ -stable map germ for any  $(\gamma, \delta) \in \mathcal{O}$  by Lemma 3.3. Since the infinitesimally  $\mathcal{A}$ -stable map germ  $\mathbb{R}^2 \rightarrow \mathbb{R}^3$  is an immersion or the cross cap and the singularities of  $F_{(\gamma, \delta)}$  are located on the striction curve, there exists an open neighbourhood  $U_{t_0} \subset I$  of  $t_0$  such that  $F_{(\gamma, \delta)}$  is an immersion on  $U_{t_0} \times I - \{(t_0, u_0)\}$ . Since  $\bar{I}$  is compact, we can extend  $(\gamma, \delta)$  slightly on an open interval  $I_0 \supset \bar{I}$  and there exist finitely many  $U_{t_i}$  ( $i = 1, \dots, \ell$ ) such open subsets as the above with  $I = \bigcup_{i=1}^\ell U_{t_i}$ . Then  $\mathcal{O} = \bigcap_{i=1}^\ell \mathcal{O}_{(t_i, u_i)}$  is a residual subset of  $C_{pr}^\infty(I, \mathbb{R}^3 \times S^2)$ . It is clear that the germ  $F_{(\gamma, \delta)}$  at any point  $(t, u) \in I \times J$  is an immersion or the cross cap for any  $(\gamma, \delta) \in \mathcal{O}$ . It is easy to show that the mapping  $F_\# : C^\infty(I, \mathbb{R}^3 \times S^2) \rightarrow C^\infty(I \times J, \mathbb{R}^3)$  defined by  $F_\#(\gamma, \delta) = F_{(\gamma, \delta)}$  is continuous. Since the cross cap is the stable singularities of map germs  $(\mathbb{R}^2, 0) \rightarrow (\mathbb{R}^3, 0)$ , the set  $\mathcal{S} = \{f \in C^\infty(I \times J, \mathbb{R}^3) \mid f \text{ is an immersion or the cross cap at any point } \in I \times J\}$  is an open subset. Therefore,  $\mathcal{O} = F_\#^{-1}(\mathcal{S})$  is an open subset of  $C_{pr}^\infty(I, \mathbb{R}^3 \times S^2)$ . This completes the proof of Theorem 1.1.  $\square$

## References

- [1] V. I. Arnol'd, S. M. Gusein-Zade and A. N. Varchenko, *Singularities of Differentiable Maps vol. I*, Birkhäuser (1986)
- [2] T. Banchoff, *Front cover of Notices of of A.M.S.*, (<http://www.geom.umn.edu/locate/tfb/art/>), vol 44 No. 3 (1997)
- [3] J.P.Cleave, *The form of the tangent developable at points of zero torsion on space curves*, Math.Proc.Camb.Phil. vol 88 (1980), 403–407
- [4] C. G. Gibson, K. Wirthmüller, A.A.du Plessis and E.J. N. Looijenga, *Topological stability of Smooth Mappings*, Lecture Notes in Math. vol 552 Springer (1970)
- [5] M. Golubitsky and V. Guillemin, *Stable Mappings and Their Singularities*, GTM 14 Springer (1973)
- [6] A. Gray, *Modern Differential Geometry of Curves and Surfaces*, CRC PRESS (1993)

- [7] J. Hoschek and H. Pottman, *Interpolation and approximation with developable B-spline surfaces*, in *Mathematical Methods for curves and surfaces*, ed. by M. Dæhlen, T. Lyche and L.L. Schumacker, Vanderbilt Univ. Press (1995), 255–264
- [8] G. Ishikawa, *Determinacy of envelope of the osculating hyperplanes to a curve*, Bull.London Math.Soc., vol 25 (1993), 787–798
- [9] G. Ishikawa, *Developable of a curve and determinacy relative to osculation-type*, Quart. J. Math. Oxford, vol 46 (1995), 437–451
- [10] S. Izumiya and T. Sano, *Generic affine differential geometry of space curves*, Proceedings of the Royal Society of Edinburgh, vol 128A (1998), 301–314
- [11] S. Izumiya, H. Katsumi and T. Yamasaki, *The Rectifying developable and the Darboux indicatrix of a space curve*, to appear in Banach Center Publications, Caustics '98, (1999)
- [12] S. Izumiya, D.-H. Pei and T. Sano, *The lightcone Gauss map and the lightcone developable of a spacelike curve in Minkowski 3-space*, to appear in Glasgow Math. J., (2000)
- [13] J. Martinet, *Singularities of Smooth Functions and Maps*, London Math. Soc. Lecture Note Series, Cambridge Univ. Press, vol 58 (1982)
- [14] D. Mond, *Singularities of the tangent developable surface of a space curve*, Quart. J. Math. Oxford, vol 40 (1989), 79–91
- [15] I. Porteous, *The normal singularities of submanifold*, J. Diff. Geom., vol 5 (1971), 543–564
- [16] T. Sasaki, *Projective Differential Geometry and Linear Homogeneous Differential Equations*, Rokko Lectures in Mathematics, Kobe University, vol 5 (1999)
- [17] O. P. Scherbak, *Projectively dual space curve and Legendre singularities*, Sel. Math. Sov., vol 5 (1986), 391–421
- [18] M. Schneider, *Interpolation with Developable Strip-Surfaces Consisting of Cylinders and Cones*, in *Mathematical Methods for curves and surfaces II*, ed. by M. Dæhlen, T. Lyche and L.L. Schumacker, Vanderbilt Univ. Press, (1998), 437–444
- [19] H. Whitney, *The singularities of a smooth  $n$ -manifold in  $(2n - 1)$ -space*, Annals of Math., vol 45 (1944), 247–293