



THE UNIVERSITY *of* EDINBURGH

Edinburgh Research Explorer

## Review of magnetic gear technologies and their applications in marine energy

**Citation for published version:**

McGilton, B, Crozier, R, McDonald, A & Mueller, M 2017, 'Review of magnetic gear technologies and their applications in marine energy' IET Renewable Power Generation, vol 12, no. 2, pp. 174-181. DOI: 10.1049/iet-rpg.2017.0210

**Digital Object Identifier (DOI):**

[10.1049/iet-rpg.2017.0210](https://doi.org/10.1049/iet-rpg.2017.0210)

**Link:**

[Link to publication record in Edinburgh Research Explorer](#)

**Document Version:**

Publisher's PDF, also known as Version of record

**Published In:**

IET Renewable Power Generation

**General rights**

Copyright for the publications made accessible via the Edinburgh Research Explorer is retained by the author(s) and / or other copyright owners and it is a condition of accessing these publications that users recognise and abide by the legal requirements associated with these rights.

**Take down policy**

The University of Edinburgh has made every reasonable effort to ensure that Edinburgh Research Explorer content complies with UK legislation. If you believe that the public display of this file breaches copyright please contact [openaccess@ed.ac.uk](mailto:openaccess@ed.ac.uk) providing details, and we will remove access to the work immediately and investigate your claim.



# Review of magnetic gear technologies and their applications in marine energy

ISSN 1752-1416  
 Received on 27th March 2017  
 Revised 2nd October 2017  
 Accepted on 17th October 2017  
 doi: 10.1049/iet-rpg.2017.0210  
 www.ietdl.org

Ben McGilton<sup>1</sup> ✉, Richard Crozier<sup>2</sup>, Alasdair McDonald<sup>3</sup>, Markus Mueller<sup>2</sup>

<sup>1</sup>Wind and Marine Energy, Center for Doctoral Training, Institute for Energy Systems, University of Edinburgh, Edinburgh, Scotland

<sup>2</sup>Institute for Energy Systems, University of Edinburgh, Edinburgh, Scotland

<sup>3</sup>University of Strathclyde, Department of Electronic & Electrical Engineering, Glasgow, Scotland

✉ E-mail: ben.mcgilton@ed.ac.uk

**Abstract:** The marine energy industry is in its early stages but has a large potential for growth. One of the most significant challenges is the reduction of operation and maintenance costs. Magnetic gears (MGs) offer the potential for long periods between maintenance intervals due to their frictionless torque transmission which could reduce these costs. This study presents a summary of the state of the art in MG technology and then investigates its potential for marine energy applications. A brief overview is given of the state of the marine energy industry and the environment in which marine energy converters (MECs) operate. A short history of MG development over the past century is then presented followed by a discussion of the leading MG technologies and their relative advantages. In order to demonstrate the potential of MGs in marine applications, the current technologies, i.e. mechanically geared and direct drive machines, are examined in terms of sizing, reliability and economic value using previous studies on a similar technology, namely wind. MGs are applied to four types of MECs to demonstrate how the technology can be incorporated. The potential to deploy at scale and potential obstacles to this are then discussed.

## 1 Introduction

With an estimated 95 TWh/year of tidal energy and 69 TW/year of wave energy in the UK alone [1], combined marine energy presents a promising economic opportunity and has led to the development of numerous devices focused on harnessing this resource. These devices vary quite substantially depending on how they interact with the marine energy be it a tidal stream or wave (heave, pitch etc.) and the orientation of their power take off (PTO) systems. Though a wide range of devices exist at various stages of development, there are common issues that exist across many designs that present obstacles to their full-scale deployment as viable alternatives to standard energy sources. When compared to onshore renewable technologies, wind in particular, a key obstacle is the significantly higher operation and maintenance (O&M) costs associated with any offshore installation [2] including specialised equipment, heightened health and safety requirements, and the need for weather windows to perform necessary maintenance and repair procedures. This is exacerbated by operating in the harsh environments usually associated with marine energy, i.e. high wave height, strong tidal flows and a highly saline environment. Additionally, the forces these devices can encounter during normal operation can vary greatly with storms and irregular sea conditions requiring most devices to have a high degree of survivability. These associated costs have resulted in a focus on low failure, robust systems.

The low-frequency oscillation, and therefore low velocity motion, of both wave and tidal stream energy means that conventional generator types which typically operate at 1000 s of rpm would result in extremely large and inefficient designs if directly connected. For this reason, systems that use these generator types have required a mechanical gearbox to increase the airgap velocity. However, studies in wind energy, the closest comparable technology, have shown that mechanical gear systems are a leading cause of down time with the highest associated costs to repair [3]. When added to a highly saline marine environment there is increased chance for failure of mechanical transmission elements. Alternatively, in order to eliminate this source of failure, direct drive (DD) systems have been proposed [4]. However, DD generators are much larger requiring high pole numbers and robust

power electronics that have been shown to result in collectively similar down times as a geared system [5].

A number of researchers, designers and developers have proposed intermediate energy conversion and conditioning steps using mechanical or hydraulic means in order to step down force/torque and step up speed. These systems have also been proposed as a means to convert linear bidirectional motion into unidirectional rotational motion which is generally the easiest input to produce electrical power. The downside of these intermediate steps is that they can have poor efficiency, with some calculations putting the value at 60% [2], and further reliability and O&M issues.

A possible solution to these issues is the magnetic gear (MG) concept or similar pseudo-DD systems that offer reduced mechanical failure rates while allowing a smaller, higher frequency machine. Furthermore, the MG has advantages over its mechanical counterpart, namely contactless torque transmission, greatly reduced lubrication requirements, inherent overload protection and the option for parts of the system to be hermetically sealed. Additionally, MG systems have been developed to convert linear motion to rotational with high efficiency allowing for more standard electrical machines to be used. This paper reviews MGs as a technology and discusses its particular advantages to marine energy and the obstacles therein.

## 2 Magnetic gears

Other papers are already available which give an extensive review of MG development over the past 100+ years [6, 7]. Therefore, this paper will only give a summary of the main developments of the technology and focus on the designs that the authors feel are most relevant to marine energy.

### 2.1 Early magnetic gears

MGs have been of interest since the early 20th century with the earliest designs being very similar to conventional mechanical gears with the gear teeth replaced with magnetic counterparts [8, 9]. However, these designs received little attention, most likely due to the low torque densities achieved as a result of the permanent magnet (PM) materials available at the time (namely SmCo5). A

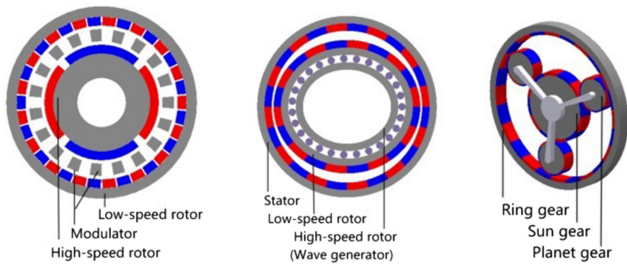

Fig. 1 Concentric, harmonic and MPGs [6]

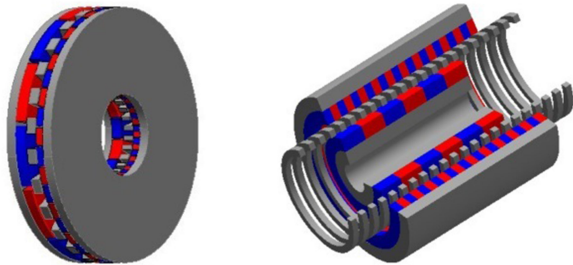

Fig. 2 Disc-type and linear-type CMG topologies [6]

renewed interest came in the 1980s with the development of neodymium iron boron (NdFeB) magnetic material though the designs still relied on direct mechanical substitution, thus resulting in poor PM utilisation and never achieved torque densities high enough to compete with traditional mechanical alternatives. [10, 11]

## 2.2 Modern magnetic gears

As of the turn of the century there are three types of MG that can be classified as modern as they have comparable torque densities to that of traditional mechanical gears (50–150 kNm/m<sup>3</sup> for a helical gear and 100–200 kNm/m<sup>3</sup> for a spur type gear). These are the field flux modulated MG (FFM-MG), the harmonic gear and the magnetic planetary gear (MPG) types as shown in Fig. 1.

While these are considered the leading models other designs are in development and a special note is made for a recent development by Dave Rodgers *et al.* [12] who, as of 2015, developed a variation on a conventional worm and wheel gear with helical magnetic arrangement. Experimentation has shown potential gearing ratio exceeding 100:1 and airgap shear stress in the range of 485 kNm/m<sup>2</sup>. Reportedly successful in both computer modelling and prototype demonstration, as a very new technology further verification and demonstration of operation is required. Additionally, being a worm type gear, the high shear stress will be localised in a small part of the machine and utilisation of total PM material will be low.

The harmonic gear [13] has shown very promising torque densities in the range of 150 kNm/m<sup>3</sup>. Though attractive for its torque density, high gear ratios and smooth torque transmission, it is complicated to construct and relies on a flexible low-speed rotor to produce a time-varying sinusoidal variation of the magnetic field in the airgap between the rotors. The gear ratio of a harmonic gear is given as

$$G_r = \frac{(-1)^{(k+1)} p_w}{p_l} \quad (1)$$

with  $p_l$  and  $p_w$  the number of poles on the low-speed rotor and the number of sinusoidal cycles between low-speed rotor and stator, respectively, and  $k$  represents the various asynchronous space harmonics which are associated with each harmonic of the magnetic field produced by the PMs.

The MPG proposed by Cheng-Chi Huang *et al.* [14] which operates like a traditional mechanical planetary gear has reported torque densities of over 100 kNm/m<sup>3</sup> and offers the same

advantage of three transmission modes along with MGs contactless advantages and no lubrication requirements. Its gearing ratio is determined by

$$G_r = \frac{p_r}{(p_s + p_r)} \quad (2)$$

where  $p_r$  and  $p_s$  are the pole pairs on the magnetic ring gear and sun gear, respectively, with the pole-pair relationship on the planetary gear determined by

$$p_p = \frac{(p_r - p_s)}{2} \quad (3)$$

As with the harmonic gear the MPG is capable of high torque densities and gearing ratios but is more complex than the concentric design. Additionally, not all magnetic material is utilised during torque transmission.

In 2001, Atallah and Howe [15] proposed what is generally considered the leading design for MGs, the concentric MG (CMG). Though a similar design can be seen in T. B. Martin's 1968 patent, 'Magnetic transmission' [16], it was in Atallah and Howe's paper that the design's high torque capabilities were demonstrated.

The CMG falls into the category of FFM-MG in that they employ ferromagnetic pole segments in the airgap between the rotors in order to modulate the magnetic flux active between rotors. This design allowed for full utilisation of all PM material and resulted in high torque density in the range of 70–150 kNm/m<sup>3</sup> with a relatively simple design. Additionally, after proposing the CMG, Atallah *et al.* demonstrated two other forms of this MG, the linear and axial field models [17, 18] as can be seen in Fig. 2. This adaptability makes the FFM-MG design particularly useful in marine energy where a number of PTOs exist depending on how the device interacts with the incoming waves or tidal stream. There are two modes of operation with this type of MG. Either the ferromagnetic poles are held stationary and the outer and inner magnetic rotors are allowed to rotate, or the ferromagnetic poles are allowed to rotate with one of the other rotors held stationary. The modes affect the possible gear ratio and the direction of rotation. The number of ferromagnetic segments for all three topologies are related by

$$n_s = p_l + p_h \quad (4)$$

where  $n_s$ ,  $p_l$  and  $p_h$  are the ferromagnetic pole pairs, the magnetic pole pairs on the low-speed side and the magnetic pole pairs on the high speed side, respectively. The gear ratio  $G_r$ , with the ferromagnetic segments held stationary, is then determined by

$$G_r = \frac{p_l}{p_h} = \frac{(n_s - p_h)}{p_h} = \frac{-\omega_h}{\omega_l} \quad (5)$$

where  $\omega_h$  and  $\omega_l$  are the rotational speeds of the high and low-speed rotors, respectively. The minus sign here indicates that the rotors will rotate in opposite directions. Alternatively, with the ferromagnetic elements allowed to rotate and the outer low-speed rotor held stationary, the gear ratio is as follows:

$$G_r = \frac{n_s}{p_h} = \frac{\omega_h}{\omega_s} \quad (6)$$

where  $\omega_s$  is the rotational speed of the ferromagnetic segments. Thus, the rotors will rotate in the same direction and a slightly higher gear ratio is achievable. The torque densities of the leading MG types and the mechanical alternatives are shown for comparison in Table 1.

There is a limiting factor with pole number in that it is found that with higher ratios, large harmonics become an issue. There are also physical constraints due to minimum magnetic pole size. While a thorough analysis of the cogging torque is available [19],

**Table 1** Torque density for rotating gears

Gear type	Torque density, kNm/m <sup>3</sup>
mechanical spur gear	100–200
mechanical helical gear	50–150
CMG	70–150 [15]
magnetic harmonic gear (1 stage)	140–180 [13]
magnetic harmonic gear (2 stage)	75 [13]
MPG	> 100 [14]

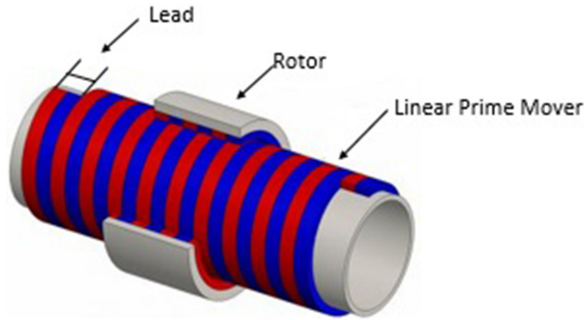
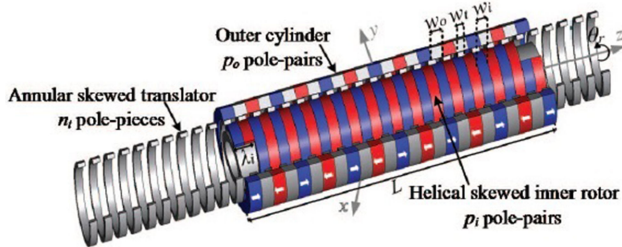
**Fig. 3** Magnetic lead screw**Fig. 4** MG lead screw [28]**Table 2** Force density for linear actuation magnetic gears

Gear type	Force density, kN/length
MGLS	1.87 [28]
MLS/TROMAG	2.6 [2]
LMG	1.95 [17]

the following is generally used as an indication of the severity of cogging torque:

$$f_c = \frac{2pn_s}{\text{LCM}(p, n_s)} \quad (7)$$

where  $p$  is the pole number of either inner or outer rotors and LCM is the least common multiple of this and the ferromagnetic pole number. For the least cogging torque this number should be close to unity. Apart from these core design equations, there are numerous factors which can affect the maximum torque capabilities of a MG. While some of these parameters have been examined individually [20–22], it was with Evans and Zhu's [23] paper that the coupling effects between parameters were established with a detailed examination of factors like optimal gear ratio, ferromagnetic pole geometry and PM thickness.

### 2.3 Trans-rotary MGs

Also falling within the scope of MGs are relatively new concepts of trans-rotary type MGs which operate similar to that of mechanical lead screws in converting linear motion to rotary with the thread being replaced with magnetic material (Fig. 3). This form of MG is highly applicable to wave energy as the typically low-speed linear motion of, say, a heaving buoy type wave energy converter (WEC) will not only have a speed increase but could also allow a more conventional electrical machine to be applied.

Though a patent for a magnetic screw device was recorded in the 1997 [24] it was with Wang *et al.* in 2011 [25] that the high force density capabilities of a magnetic lead screw (MLS) was analysed in detail. From this analysis it was determined that a thrust force density in excess of 10 MN/m<sup>3</sup> was possible in models with airgaps varying from 0.4 to 0.8 mm with a lead ( $\lambda$ ) >7 mm. With this function established in 2012, Pakdelian *et al.* [26] developed the concept by developing the speed–torque relationship and the design and scaling of such a device now daubed the trans-rotary MG or TROMAG for its gearing applications. Here the gear ratio is established as the ratio of the rotor angular speed to the translator linear speed  $\omega$  (rad/s) and  $V$  (m/s), respectively. With this the rotor speed in terms of revolutions per second is defined as

$$n = \frac{V}{PW} \quad (8)$$

where  $P$  is the number of poles and  $W$  is the width of each magnet. The gear ratio is then obtained as

$$G = \omega/V = 2n\pi/V = 2\pi/PW \quad (9)$$

By employing a low number of poles and narrow magnets it is then theoretically possible to convert a speed of 1 m/s on the linear translator to 1500 rpm on the rotor. With both the high torque and large gearing effects established, the technologies application to wave energy was clear and papers developing this concept were published [2, 27].

While the TROMAG has great potential in WECs, the requirement for a large amount of magnetic material on the linear translator makes the devices expensive. A recent paper [28] has seen the development and analysis of a new magnetically geared lead screw (MGLS) that combines the operating principles of a linear MG (LMG) and a TROMAG. The design consists of three main sections: an inner rotor of helically skewed, radially magnetised pole pairs ( $p_i$ ), an outer cylinder structure consisting of magnetic elements arranged with flux focusing steel segments and the translator made of ferromagnetic annular skewed pole pieces ( $n_i$ ) (Fig. 4). With the outer section held stationary a velocity relationship can be established such that

$$\omega_i = v_t \left( \frac{n_i}{(p_i k_i)} \right) \quad (10)$$

where  $\omega_i$  is the angular velocity of the inner rotor,  $v_t$  is the linear translator velocity and  $k_i$  is given by

$$k_i = \frac{\lambda_i}{(2\pi)} \quad (11)$$

where  $\lambda_i$  is the inner rotor lead.

The proposed design was modelled and the analysis of this presented a force density capability of 1.87 kN for a given length stroke which is compared with the force densities calculated for the LMG and TROMAG in Table 2. While the MGLS has the lowest force density of the three linear actuation MGs considered, the force per magnet for the MGLS will not change as the stroke length increases and the increase in cost will be much less due to the use of ferromagnetic, as opposed to permanent magnetic, material for the prime mover.

### 2.4 Further developments in MGs

Building on the core concepts, further work has been undertaken to increase the functionality of MGs with a key achievement being the development of variable gear ratio designs. This is potentially an important development in applying the technology to marine energy as sea states can often vary wildly and being able to change the transmission ratios gives designers more scope regarding control such as maintaining a generators optimum speed from a varying input torque. As mentioned, the planetary type MG is capable of three transition modes [14] but further work has been



done on allowing the concentric type MG to be similarly adapted. First explored by Wang *et al.* [29], the principle of operation is that, in a typical CMG design, instead of having a fixed rotor, it is allowed to rotate such that the rate of change in magnetic field seen by the other two rotors is adaptable over a given ratio range. This concept is further explored in terms of topology and application [30–34] and with the use of non-rare earth magnets with pole changing capabilities [35].

### 3 Application to marine energy

While MGs have been suggested for the electric automotive and aerospace industries where size, efficiency and low O&M costs are of key concern, MG technology is also highly attractive for marine energy applications.

The following section discusses its usefulness when considering machine sizing and reliability drawing from established machine sizing formulae and studies conducted into the wind industry. Finally, a brief discussion is included on some of the inherent advantages of MG technology.

#### 3.1 Machine sizing

The physical size of machines is of particular concern for offshore installations. Larger devices make transport difficult and when installing require specialised equipment like ship mounted cranes which can be very expensive to rent. The overall size of an electrical machine is governed by a few well established equations. The power ratings of the machine are directly related as follows:

$$P = T\omega \quad (12)$$

where  $\omega$  is the rotational speed in radian/s and  $T$  is the torque in Nm which can be calculated as

$$T = Fr = \sigma Ar = \sigma 2\pi r^2 l \quad (13)$$

where  $F$  is the equivalent force (in Newtons),  $\sigma$  is the shear stress in N/m<sup>2</sup> in the airgap,  $A$  is the area (m<sup>2</sup>) of the airgap,  $r$  and  $l$  are the radius of the airgap and length of the machine, respectively. Thus, the volume of the machine is inversely proportional to the rotational speed as follows:

$$V = \frac{P}{\omega 2\sigma} \quad (14)$$

Therefore, in order to have a small, compact machine a high rotational speed is required. With the low frequencies associated with wave and tidal energy, a speed enhancement system, usually a mechanical gearbox, will be incorporated into the device. The alternative is a very large DD machine which, as well as transport issues, has additional issues that are discussed in the following section.

#### 3.2 Mechanical gear versus direct drive for marine energy devices

Substantial published information on O&M costs is currently unavailable for marine energy devices. As mentioned, wind energy, in particular offshore wind, has similar requirements in terms of machine conditions and frequencies. A critical analysis of the trends will be made in order to demonstrate MGs potential as a viable third option.

Mechanical gearboxes are regarded as having a critical effect on reliability as the associated down time per failure is high compared with other turbine components [36, 37]. Furthermore, despite advancements traditional gearboxes have yet to achieve design life goals (20+ years), often requiring substantial repairs or overhauls [38]. This can be largely attributed to the physical interaction between mechanical elements under force. This is potentially exacerbated in a highly saline environment with irregular loadings.

In [39], Henk Pollinder *et al.* examined and compared five different generator concepts [namely: doubly fed induction

generator with three-stage gearbox (DFIG3G), DD synchronous generator with electrical excitation, DDPM generator (DDPMG), PM generator with single-stage gearbox and DFIG with single-stage gearbox] with the comparison focused on cost and annual energy yield for a given wind climate. The results of the comparison found that while the industry standard DFIG3G was the lightest and lowest costing it suffered from low energy yield with high losses, 70% of which are associated with the mechanical gearbox. Furthermore, it was noted that since the machine consists mostly of components consisting of copper and iron, major improvements and cost reductions cannot be expected. The DDPMG, though more expensive due to its size and power converter requirements, was shown to have the highest energy yield. Additionally, a key point was that, unlike the DFIG3G, further improvements can be reasonably expected due to the improvement in power electronics, the expected reduction of PM material cost and further optimisation and integration of the generator system. Therefore, it would suggest that using DD systems and eliminating the gearbox associated O&M costs would result in a superior machine.

However, along with requiring a physically larger system there are further issues. In [5], David McMillan and Ault established a techno-economic comparison of operational aspects between DD and gearbox-driven (GD) wind turbines by providing analytical calculations regarding the availability of traditional wind turbine devices. From this, a clearer understanding of the technical and economic merits of DD and GD systems can be gained. The paper supposes that the assumption that DD systems have reduced maintenance issues due to the elimination of those associated with a gearbox only holds if all other factors remain unchanged and highlights findings that indicate much higher failure rates of electrical components and generators of DD turbines when compared with GD equivalents. Though the paper excluded consideration of PM machines due to the lack of deployment, it provides some interesting results with regards to DD versus GD machines. The results state that while DD is marginally better in terms of availability, looking at revenue generated suggests GD machines have a much larger economic benefit and that from an economic analysis GD machines are still preferable unless manufacturing costs of DD technology can be significantly reduced. Nonetheless, it was surmised that the operational availability of DD can be significantly higher than GD as long as the majority of generator failures are minor electrical failures as opposed to severe mechanical failures (e.g. bearing problems).

Tavner *et al.* [40] found that DD systems were less reliable due to increased generator, inverter and electrical system failures. However, the authors recognised that overall availability would also be affected by component repair times, i.e. mean time to repair for a gearbox is much more than electronics. This issue becomes much more relevant in offshore installations as extensive work can be greatly delayed due to accessibility, weather windows and equipment or vessel availability.

In [41], Echavarria *et al.* analysed a similar data set and found that DD systems have twice the generator failures as GD equivalent systems and that the power electronics had an ~50% higher failure rate in DD synchronous machines compared with an induction machine equivalent.

It should be noted that power electronics have greater opportunity for design redundancy due to component size and cost. There is ongoing research and development in related fields, such as high-voltage DC systems [42], which could be applied.

A MG system then could potentially result in a superior system which combines the higher frequency, smaller and lighter machines without the O&M costs associated with a mechanical gear.

#### 3.3 Magnetic gear advantages

Survivability is a key concern for marine energy converters (MECs) which are often subjected to extreme conditions. The inherent overload protection of MGs has great potential in marine energy where forces can vary dramatically depending on environmental conditions. The nature of a MG allow the rotors to slip in the event of excessive force applied without damage

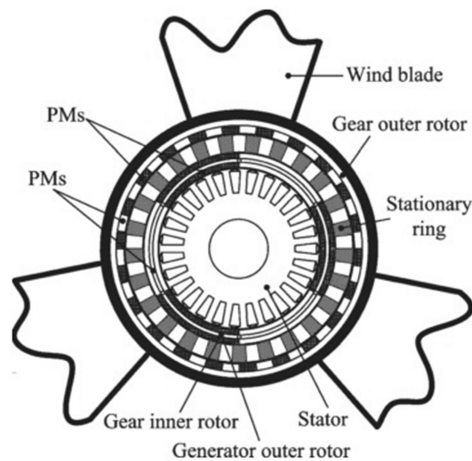

Fig. 5 Proposed tidal turbine MG system option [44]

occurring to the gear components and will naturally realign under normal operations. This contrasts with mechanical gears which in a similar event could result in significant damage. Additionally, the lack of interlocking parts greatly reduces the systems requirements for lubrication, though bearing lubrication will still be required.

Finally, as torque is transferred contactlessly, additional options are available with regards to system sealing with sections being optionally hermetically separated, which can be of great benefit when considering machine marinisation.

#### 4 Integration of marine energy converters with magnetic gears

This section looks at four marine energy devices that would benefit from MG integration. The chosen devices have very different PTO systems and operating principals in order to demonstrate the wide applicability of MG's in this area.

##### 4.1 Tidal turbine

The horizontal axis bladed tidal turbine [43] device is perhaps the most straight forward comparison with wind turbines due to the similarities in machine orientation and PTO. For this type of MEC, a system similar to that proposed in [44] is suggested. This design uses a CMG coaxially coupled with a PM generator (PMG) demonstrated in Fig. 5. The outer rotor of the CMG is connected to the blades which capture the incoming fluid energy directly. The proposed gear ratio was 7.33 considering an average wind speed of 7 m/s. To emphasise the advantages of this design, a comparison was made to two similarly rated machines, a standard planetary geared machine and a DD machine. Through standard sizing calculations it was found that the MG machine (MGM) was the lightest and smallest. Additionally, when a cost analysis of the systems was undertaken (focusing on material costs only) while the MGM was more expensive than a PMG it was still cheaper than the DD option. A prototype was built to demonstrate the functionality of the proposed system and achieved high torque values. The proposed system is directly applicable to a tidal turbine though further considerations would have to be made regarding marinisation.

##### 4.2 Wave energy converters

As mentioned, WECs have been developed in a wide variety of devices with over 1000 patents being registered as of 2008 [45] and 226 registered companies listed on the European marine energy centre (EMEC)'s website [46]. It is an ongoing process to accurately classify the varied devices into groups for comparison. A fair assessment is to group the devices according to working principle of their PTOs [47]. This allows for three distinct classes to be defined as a starting point for device classification:

- Oscillating water column which operate with an air turbine.

- Over-topping devices which use low-head hydraulic turbines.
- Oscillating body types which generally employ hydraulics or linear generators.

The oscillating body type group will be the focus in this section due to groups reliance on either low-efficiency hydraulics and similar intermediary stages or linear DD generators which tend to be physically large with poor magnetic material utilisation.

Within the oscillating body group, the current MG systems are most applicable to either linear or rotary type PTOs. Table 3 presents the main MG types discussed in this work along with their advantages and disadvantages in wave energy.

##### 4.3 Heaving buoy wave energy converter (with linear generator)

Point absorber, heaving buoy WECs work by a simple concept of using a buoyant structure that oscillates with incoming waves. The PTO of these devices can be quite complicated, however, due to the linear nature of the devices primary motion. There have been some proposed models that use a linear generator [48] but due to the low frequency a large amount of poles are required and there is poor utilisation of magnetic materials. As previously mentioned, Atallah has proposed a LMG device. This would allow for direct conversion of the heave motion of a buoy type system without linear to rotational mechanisms such as a rack and pinion or ball-screw systems [49].

In [50], a proposed serially integrated system saw the use of a LMG cascaded with a linear PM generator. This allowed the high-speed mover of the gear and the translator of the generator to share the same shaft. With the proposed design the low-speed mover of the MG is coupled with the heaving buoy structure as shown in Fig. 6. As the buoy rises and falls with wave propagation, the high-speed mover connected to the linear generator's speed is amplified by a factor of the gear ratio. A similar rated machine without the MG system was calculated to have a volume four times that of the proposed system and with greater volumes of PMs, iron cores and copper windings (167, 214 and 271%, respectively) would have a considerably higher cost. Additionally, the gearless machine was calculated to have higher copper losses. Therefore, while greatly reducing cost and volume, the proposed machine has a greater efficiency and power density.

##### 4.4 Heaving buoy wave energy converter with magnetic lead screw

As previously mentioned, the use of an MLS would allow for rotating electrical generators to be applied to the typically linear motion of WECs. This would allow for more industry standard equipment to be used along with potentially more compact PTOs. In order to develop this concept, Holm *et al.* [2] presented work on applying a MLS PTO with a Wavestar 500 kW WEC. The Wavestar concept operated as a point absorber with multiple floats

**Table 3** Comparison of magnetic gear types for wave energy application

Magnetic gear type	Main advantages	Disadvantages	Primary marine application
CMG	compact design, high torque density, good balance of forces due to concentric design	complicated for multiple stages	rotary type PTOs
axial MG	compact design, readily adaptable for multiple stages	lower torque density than concentric, possible imbalance of attractive forces due to orientation	rotary type PTOs
harmonic magnetic gear	very high torque density	complicated structure	rotary type PTOs
MPG	three modes of transmission, high torque density	complicated structure, not all magnetic material constantly in use	rotary type PTOs
LMG	direct linear motion utilisation	not all magnetic material constantly in use	linear (heave) type PTOs
MGLS	trans-rotary operation allows use of rotary generator, high force density, low-cost primary linear mover	complicated bearing system	linear (heave) type PTOs
TROMAG	trans-rotary operation allows use of rotary generator, simple interaction between movers	not all magnetic material constantly in use	linear (heave) type PTOs

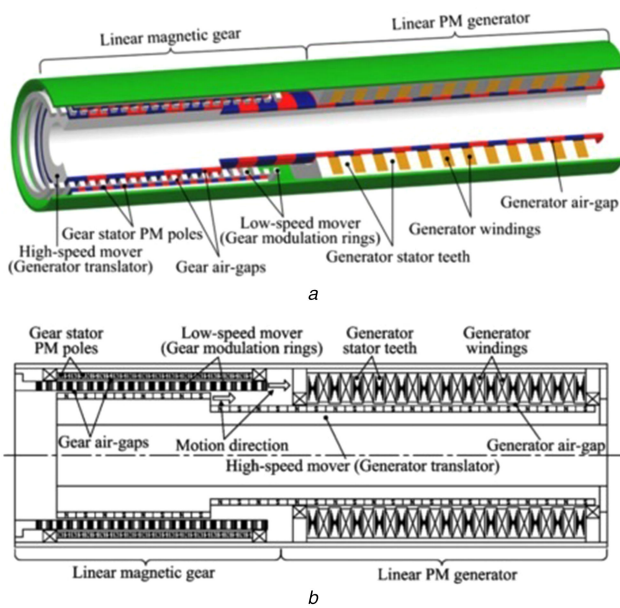

**Fig. 6** Proposed heaving buoy MG system option  
(a) Solid model, (b) Schematic diagram [50]

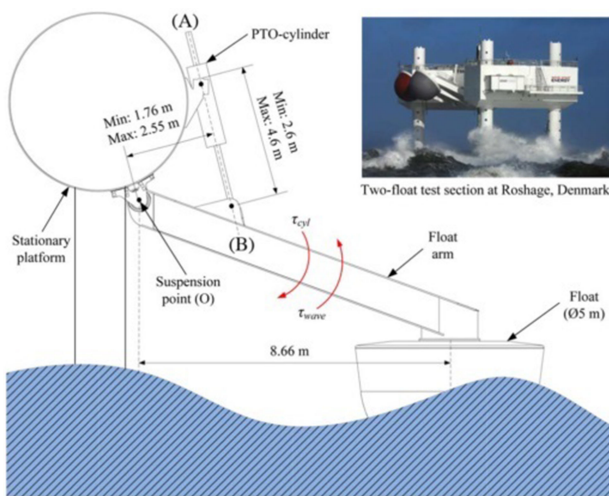

**Fig. 7** Wavestar 500 schematic diagram [2]

being attached to a stationary platform [51]. The aim of the work was to design a PTO incorporating the MLS technology which would have the maximum requirements of 500 kN force with a 2 m stroke that could replace the hydraulic PTO [52]. The proposed system can be shown in Fig. 7. After calculating the required

dynamics a scale model was built for 17 kNm which resulted in an efficiency in the range of 80% with this value expected to increase given that the test rig was only capable of 25% of the anticipated maximum speed.

#### 4.5 Oscillating wave surge converter

In their report funded by *n-power* juice [53], Ozan Keysan *et al.* looked at the Aquamarine Oyster oscillating wave surge converter with the aim of suggesting an optimal generator topology as opposed to the hydraulic system then employed.

With an average speed of 0.45 rpm and 164 kW average power, the high torque requirements and very low speed meant that a DD solution resulted in a heavy, low-efficiency generator. By using a single-stage gearbox with gear ratio of either 10–15:1, the generator efficiency was increased to 90% and reduced the total mass substantially. In the proposed design, two C-GEN generators [54] with two gearboxes would be attached to each side of the Oyster flap. The gearboxes are coupled to the devices flap shaft with the gearbox output shaft connected to the torque arm of a generator. It is proposed to substitute the mechanical gearboxes suggested in the report with CMGs. Thus, the same overall design can be maintained and, though a MG system would be initially more expensive than a traditional mechanical gear, with its inclusion in the system similar efficiencies and mass reductions can be expected along with a reduction in O&M costs and increased reliability. This design would resemble that shown in the report which can be seen in Fig. 8. As an example of the scale required for such a system a suitable 12:1 ratio gearbox capable of 3.1 MNm was successfully modelled and analysed using the electromagnetic field simulation software, MagNet [55] (Fig. 9). The torque requirement was chosen to fulfil the operating range of the Oyster 99.95% of the time. The resulting model was 4.2 m in diameter and 2 m in length. Although the Aquamarine Oyster has been discontinued, similar devices like the Langlee Robusto [56] and the AW-Energy Ltd WaveRoller [57] are based on similar concepts that could also benefit from MG adaptation. Additionally, the mode of operation is similar to that of other oscillating body devices such as the new mocean energy device [58] currently in development.

## 5 Discussion

The cases presented show the suitability of MG technology to marine wave and tidal energy devices. While the potential advantages have been explored, the technology faces some obstacles to its deployment across the marine energy industry. A leading issue facing MG deployment is the high cost of the PM material meaning that high torque systems are currently expensive and in a new industry, like wave and tidal energy, this factor could result in devices being uncompetitive. Furthermore, with China producing over 90% of all high strength, sintered neo magnets in

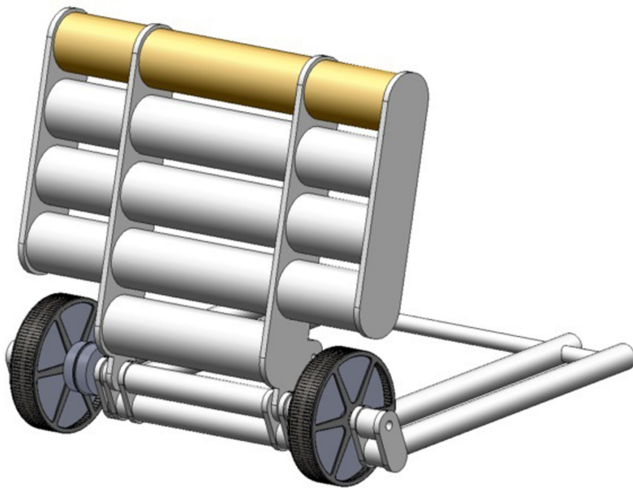

**Fig. 8** Proposed oyster configuration with two MGs connected to two standard generators [53]

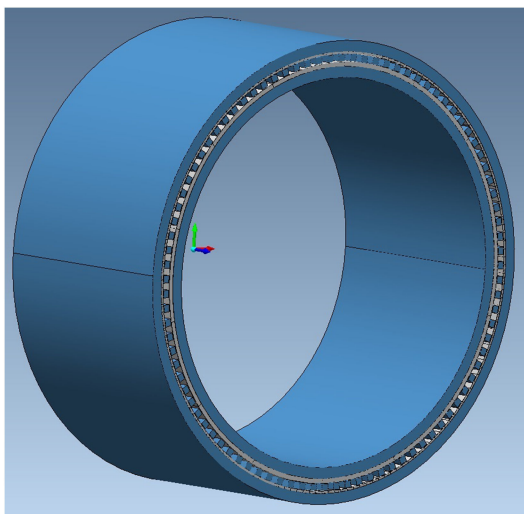

**Fig. 9** Model MG as developed in MagNet

the last 10 years, the cost is subject to variation depending on international markets [59]. With the primary advantage of MGs being the expected large reductions in O&M from life cycle costs, it is essential that these savings are worth the high capital costs. As there are currently no high torque MGs in long-term operation, considerable testing is required on high torque systems to ensure that other O&M issues do not occur that would offset the potential savings. Further testing is also required to establish the MG technologies feasibility in a marine environment. Neodymium is highly susceptible to corrosion so if the system is not hermetically sealed substantial coatings may be required to protect the magnets. This could result in larger airgaps and lower the torque. Additionally, being a relatively new technology, the manufacturing process for MGs is expensive further increasing the expected cost of systems. In order to address these issues, correct optimisation procedures must be developed such that MGs are designed with an optimal cost to torque relationship and manufacturing procedures advanced such that MGs can be produced cost effectively and efficiently.

## 6 Conclusion

A review of MG technology has been presented in the context of their applicability to a selection of marine energy devices. The comparison made between geared and gearless systems found that although gearless systems had some O&M cost benefits from the elimination of a mechanical speed enhancement element, the resulting machines are large and expensive. Additionally, the fully rated converters required for DD machines show cumulatively

similar downtime over extended operation periods to that of geared machines. The MG is a potentially ideal compromise having the benefits of both topologies. To further demonstrate the applicability, the technology was conceptually applied to four existing marine energy devices with varied PTO systems using existing proposed MG designs. Though there are obstacles facing MGs use in marine applications, primarily the high cost of the PM material, reductions can be expected with systems being mass produced with advanced design optimisation procedures. With similar torque values as mechanical gears, along with great reductions in O&M costs and overload protection, MGs can be an economically and functionally superior option in MECs.

Further work is suggested to compare the true costs and benefits of using a MGM over traditional systems. This would involve estimating savings in O&M costs and assessing their offset against the high material and construction costs. Furthermore, the designs conceptually outlined in this paper should be investigated to develop strategies for marinisation and general MEC integration.

## 7 Acknowledgments

The authors acknowledge the support of the U.K. Engineering and Physical Science Research Council, EPSRC, for the award of a studentship to Ben McGilton. The studentship is part of the Wind and Marine Energy, Centre for Doctoral Training.

## 8 References

- [1] Corsatea, T.D., Magagna, D.: 'Overview of European innovation activities in marine energy technology'. JRC Science and Policy Reports
- [2] Holm, R.K., Berg, N.I., Walkusch, M., *et al.*: 'Wave energy conversion', *Deep Sea Res. B, Oceanogr. Lit. Rev.*, 2013, **30**, (6), p. 491
- [3] Carroll, J., McDonald, A., McMillan, D.: 'Failure rate, repair time and unscheduled O&M cost analysis of offshore wind turbines', *Wind Energy*, 2015, **19**, <http://doi.wiley.com/10.1002/we.1887>
- [4] Baker, N.J., Mueller, M.A.: 'Direct drive wave energy converters', *Rev. Energies Renouvelables*, 2001, pp. 1–7
- [5] McMillan, D., Ault, G.W.: 'Techno-economic comparison of operational aspects for direct drive and gearbox-driven wind turbines', *IEEE Trans. Energy Convers.*, 2010, **25**, (1), pp. 191–198
- [6] Tlali, P., Wang, R.-J., Gerber, S.: 'Magnetic gear technologies: a review'. Int. Conf. on Electrical Machines (ICEM), 2014, 2014, pp. 544–550
- [7] Li, X., Chau, K.-T., Cheng, M., *et al.*: 'Comparison of magnetic-gear permanent magnet machines', *Prog. Electromagn. Res.*, 2013, **133**, (2013), pp. 177–198
- [8] Armstrong, C.: 'Power-transmitting device'. US Patent, 687,292, 26 November 1901. Available at <http://www.google.co.uk/patents/US687292>
- [9] Faus, H.: 'Magnet gearing'. US Patent, 353,472, 21 August 1941. Available at <https://patents.google.com/patent/US2243555A>
- [10] Kikuchi, S., Tsurumoto, K.: 'Design and characteristics of a new magnetic worm gear using permanent magnet', *IEEE Trans. Magn.*, 1993, **29**, (6), pp. 2923–2925
- [11] Kikuchi, K., Tsurumoto, S.: 'Trial construction of a new magnetic skew gear using permanent magnet', *IEEE Trans. Magn.*, 1994, **30**, (6), pp. 4767–4769
- [12] Rodgers, D., Lai, H.C., Outram, J.: 'A novel lightweight wind turbine generator', *J. Chem. Inf. Model.*, 2013, **53**, (9), pp. 1689–1699
- [13] Rens, J., Atallah, K., Calverley, S.D., *et al.*: 'A novel magnetic harmonic gear', *IEEE Trans. Ind. Appl.*, 2010, **46**, (1), pp. 206–212
- [14] Huang, C.-C., Tsai, M.-C., Dorrell, D., *et al.*: 'Development of a magnetic planetary gearbox', *IEEE Trans. Magn.*, 2008, **44**, (3), pp. 403–412
- [15] Atallah, K., Howe, D.: 'A novel high-performance magnetic gear', *IEEE Trans. Magn.*, 2001, **37**, (4), pp. 2844–2846
- [16] Martin, T.B.Jr.: 'Magnetic transmission'. US Patent 3,378,710, 16 April 1968. Available at <http://www.google.co.uk/patents/US3378710>
- [17] Holehouse, R.C., Atallah, K., Wang, J.: 'Design and realization of a linear magnetic gear', *IEEE Trans. Magn.*, 2011, **47**, (10), pp. 4171–4174
- [18] Mezani, S., Atallah, K., Howe, D.: 'A high-performance axial-field magnetic gear', *J. Appl. Phys.*, 2006, **99**, (8), pp. 97–100
- [19] Niguchi, N., Hirata, K.: 'Cogging torque analysis of magnetic gear', *IEEE Trans. Ind. Electron.*, 2012, **59**, (5), pp. 2189–2197
- [20] Yong, L.Y.L., Jingwei, X.J.X., Kerong, P.K.P., *et al.*: 'Principle and simulation analysis of a novel structure magnetic gear'. Int. Conf. on Electrical Machines and Systems, 2008, no. 1, pp. 3845–3849
- [21] Frank, N.W., Toliyat, H.A.: 'Gearing ratios of a magnetic gear for wind turbines'. 2009 IEEE Int. Electric Machines and Drives Conf., IEMDC '09, 2009, pp. 1224–1230
- [22] Rasmussen, P.O., Andersen, T.O., Jørgensen, F.T., *et al.*: 'Development of a high-performance magnetic gear', *IEEE Trans. Ind. Appl.*, 2005, **41**, (3), pp. 764–770
- [23] Evans, D.J., Zhu, Z.Q.: 'Influence of design parameters on magnetic gear's torque capability'. 2011 IEEE Int. Electric Machines and Drives Conf., IEMDC 2011, 2011, pp. 1403–1408
- [24] Hashimoto, J., Kubo, Y.: 'A magnetic screw device'. US Patent, 5,687, 614, 1997



- [25] Wang, J., Atallah, K., Barnes, J.: 'Analysis and design of a high force density linear electromagnetic actuator'. PCIM Europe Conf. Proc., 2012, vol. 47, no. 10, pp. 177–185
- [26] Pakdelian, S., Frank, N.W., Toliyat, H.A.: Analysis and Design of the Trans-Rotary Magnetic' Energy Conversion Congress and Exposition (ECCE), IEEE, 2012, pp. 3340–3347
- [27] Lu, K., Wu, W.: 'Electromagnetic Lead Screw for Potential Wave Energy Application', *IEEE Transactions on Magnetics*, 2014, **50**, (11), pp. 2–5
- [28] Kouhshahi, M.B., Bird, J.Z.: 'Analysis of A magnetically geared lead screw', *Electrical and Computer Engineering Faculty Publications and Presentations*, 2017, (421), pp. 1–8
- [29] Wang, J., Atallah, K., Carvley, S.D.: 'A magnetic continuously variable transmission device', *IEEE Trans. Magn.*, 2011, **47**, (10), pp. 2815–2818
- [30] Chen, M., Chau, K.T., Liu, C.: 'Design of a new non-rare-earth magnetic variable gear for hybrid vehicular propulsion system', *IET Electr. Syst. Transp.*, 2016, **6**, (3), pp. 153–162. Available at <http://digital-library.theiet.org/content/journals/10.1049/iet-est.2015.0034>
- [31] Niu, S., Ho, S.L., Fu, W.N.: 'Design of a novel electrical continuously variable transmission system based on harmonic spectra analysis of magnetic field', *IEEE Trans. Magn.*, 2013, **49**, (5), pp. 2161–2164
- [32] Padmanathan, P., Bird, J.Z.: 'A continuously variable magnetic gear'. Proc. of the 2013 IEEE Int. Electric Machines and Drives Conf., IEMDC 2013, 2013, pp. 367–373
- [33] Pritchard, J., Bird, P.P.J.Z.: 'A Continuously Variable Magnetic Gear'. Electric Machines and Drives Conference, IEMDC, 2013 IEEE International, 2013, pp. 13–18
- [34] Chen, M., Chau, K.T., Li, W., *et al.*: 'Design and analysis of a new magnetic gear with multiple gear ratios', *IEEE Trans. Appl. Supercond.*, 2014, **24**, (3), pp. 3–6
- [35] Chen, M., Chau, K.-t., Lee, C., *et al.*: 'Design and analysis of a New axial-Field magnetic variable gear using pole-changing permanent magnets', *Prog. Electromagn. Res.*, 2015, **153**, no. pp. 23–32
- [36] Ribrant, J., Bertling, L.M.: 'Survey of failures in wind power systems with focus on Swedish wind power plants during 1997-2005', *IEEE Trans. Energy Convers.*, 2007, **22**, (1), pp. 167–173
- [37] Daneshi-Far, Z., Capolino, G.a., Henao, H.: 'Review of failures and condition monitoring in wind turbine generators'. The XIX Int. Conf. on Electrical Machines - ICEM 2010, 2010, pp. 1–6
- [38] Musial, W., Butterfield, S., McNiff, B.: 'Improving wind turbine gearbox reliability'. European Wind Energy Conf., 2007, pp. 1–13
- [39] Polinder, H., Van Der Pijl, F.F.a., De Vilder, G.J., *et al.*: 'Comparison of direct-drive and geared generator concepts for wind turbines', *IEEE Trans. Energy Convers.*, 2006, **21**, (3), pp. 725–733
- [40] Tavner, P.J., Bussel, G.J.W.V., Spinato, F.: 'Machine and converter reliabilities in wind turbines'. Int. Conf. on Power Electronics, Machines and Drives, no. April 2006, pp. 1–4
- [41] Echavarria, E., Hahn, B., van Bussel, G.J.W., *et al.*: 'Reliability of wind turbine technology through time', *J. Sol. Energy Eng.*, 2008, **130**, (3), p. 031005
- [42] Son, G.T., Lee, H.J., Nam, T.S., *et al.*: 'Design and control of a modular multilevel HVDC converter with redundant power modules for noninterruptible energy transfer', *IEEE Trans. Power Deliv.*, 2012, **27**, (3), pp. 1611–1619
- [43] Marsh, G.: 'Tidal turbines harness the power of the sea', *Reinf. Plast.*, 2004, **48**, (6), pp. 44–47
- [44] Jian, L., Chau, K.T., Jiang, J.Z.: 'A magnetic-geared outer-rotor permanent-magnet brushless machine for wind power generation', *IEEE Trans. Ind. Appl.*, 2009, **45**, (3), pp. 954–962
- [45] López, I., Andreu, J., Ceballos, S., Martínez, I., *et al.*: 'Review of wave energy technologies and the necessary power-equipment', *Renew. Sustain. Energy Rev.*, 2013, **27**, pp. 413–434. Available at <http://dx.doi.org/10.1016/j.rser.2013.07.009>
- [46] <http://www.emec.org.uk/marine-energy/tidaldevelopers/>, 2017
- [47] Falcão, A.F.D.O.: 'Wave energy utilization: a review of the technologies', *Renew. Sustain. Energy Rev.*, 2010, **14**, (3), pp. 899–918
- [48] Vining, A.J., Muetze, A.: 'Linear Generators for Direct-Drive Ocean Wave Energy Conversion', Electric Machines and Drives Conference, 2003, IEMDC'03, IEEE International, 2003
- [49] Agamloh, E.B., Wallace, A.K., von Jouanne, A.: 'A novel direct-drive ocean wave energy extraction concept with contact-less force transmission system', *Renew. Energy*, 2008, **33**, (3), pp. 520–529
- [50] Li, W., Chau, K.T., Jiang, J.Z.: 'Application of linear magnetic gears for pseudo-direct-drive oceanic wave energy harvesting', *IEEE Trans. Magn.*, 2011, **47**, (10), pp. 2624–2627
- [51] Hansen, R.H., Andersen, T.O., Pedersen, H.C.: 'Model based design of efficient power take-Off systems for wave energy converters'. Proc. of the 12th Scandinavian Int. Conf. on Fluids Power, 2011, pp. 1–15
- [52] Hansen, R.H., Kramer, M.M.: 'Modelling and control of the wavestar prototype'. Proc. of the 9th European Wave and Tidal Energy Conf., 2011, pp. 1–10
- [53] Keysan, O., McDonald, A., Mueller, M.: 'Aquamarine power oyster - C-GEN rotary machine design', Design, no, 2009
- [54] Keysan, O., Mueller, M., Doherty, R., *et al.*: 'C-GEN, a lightweight direct drive generator for marine energy converters'. 5th IET Int. Conf. on Power Electronics, Machines and Drives (PEMD 2010), 2010, pp. 244–244
- [55] <http://www.infolytica.com/en/products/magnet/>, 2016
- [56] <https://www.environmentalexpert.com/products/langlee-robusto-wave-energy-converters-388611>, 2017
- [57] <http://aw-energy.com/about-waveroller/waverollerconceptpl>, 2017
- [58] <http://www.moceanenergy.com/technology.html>, 2015
- [59] Jahns, T.: 'Getting rare-earth magnets out of ev traction machines: A review of the many approaches being pursued to minimize or eliminate rare-earth magnets from future ev drivetrains', *IEEE Electrification Magazine*, 2017, **5**, (1), pp. 6–18