

## Management of technical skills of highly qualified female athletes specializing in athletic jumps

RUSTAM F. AKHMETOV<sup>1</sup>, TAMARA B. KUTEK<sup>2</sup>, VICTOR K. SHAVERSKIY<sup>3</sup>

<sup>1,2,3</sup> Faculty of Physical Education and Sport, Zhytomyr State I. Franko University, UKRAINE

Published online: June 25, 2016

(Accepted for publication June 08 2016)

DOI:10.7752/jpes.2016.02089

**Abstract.** Significant improvement of efficiency in managing technical mastery of female athletes-jumpers depend on the operational response to the emerging new technologies, their approbation and implementation in practice. The article introduces new opportunities for the use of simulators in the process of technical training of highly qualified female jumpers. The authors demonstrate the principal possibility of the applied use of the "facilitating-the-leadership" simulator for improvement of motor actions of female athletes. Obtained results show evident prospects of further expanding of the use of technology and simulators in the system of present-day preparation of highly skilled female athletes.

**Keywords:** management, technology, mastery, "facilitating-the-leadership" simulator, motor apparatus.

### Introduction

The current stage of development of the global athletics is characterized by increasing rivalry in the most prestigious competitions. Under these circumstances, the effective management of preparation of female athletes aimed at resolving the primary strategic issue – to provide highly technical, physical, psychological and integrated preparedness of athletes – gains a particular importance (Platonov, 2004). Features of techniques and methods of training the best athletes in the world forced experts to pay special attention to the search of new ways to improve technical training in athletic jumps.

In recent years, in order to improve the technical mastery of highly qualified female athletes, there emerge a clear need to use technical devices and simulators that facilitate an increase in the efficiency of the training process without enhancing the volume of muscular work. There are two ways of technical training of highly qualified athletes-jumpers: The first one involves a deep analysis of the biomechanical performance of motor actions enabling to understand the causes of technical errors and to choose an individual technique variant (Gamalii, 2007; Maksymenko, 2007, Popov, 1992). In this way, there are some contradictions in the course of learning a movement and during the transition to a higher level of exercise development. Some experts (Bulatova, 1996; Platonov, 2004) believe that the internal content of movements is generated in the process of imitating some external reference forms, which are offered by the trainer as a model. Thus, it does not take into account that external forms of movement are represented by coordinating the interaction of muscle groups (intermuscular coordination) of athletes in each sports exercise. The coaches find solution to this problem in simplifying of motor tasks and dividing them into elements.

The second way is that the motor skill can be formed not only in vivo, but under conditions specifically designed for this environment. In this case, the target orientation of training movement is the formation of a new and more effective rhythm-and-pace structure of a motor skill (Akhmetov, 2004; Kutek, 2011; Popov, 2005, Shaverskiy, 2009). Thus, the way, on which one can more confidently seek to achieve a high-performance movement, is through the use of technical equipment and simulators.

*The purpose of the study* was to improve the management of the technical preparedness of female athletes specialized in high jumps with a running start using a "facilitating-the-leadership" simulator.

### Material and methods

One of the modern tools allowing one to improve the rhythm-and-pace structure of running start and repulsion in the high jump is the "facilitating-the-leadership" simulator.

The main technical requirements, which the simulator corresponds to in high jumps, are:

- application of draft force to the body of female athletes of different heights through a flexible connection, directed against the vector of gravity;
- ensuring uniform application of draft force by harness system without obstacles to the movement of athletes with increased speed;
- high accuracy of control of the initial values of draft force;
- the inability to see any part of the training device and no discomfort while performing exercises by the athlete;

- movement of the transport device on a rail of sufficient rigidity in order to avoid lateral displacements during the run;
- smooth regulation of speed of a movement of the carriage, which promotes coordination with the speed of athletes and creates conditions to manage the process of interaction with the external forces;
- automatic releasing of the suspension system at the end of repulsion, which ensures uniform application of draft force to the athlete's body.

Based on the above requirements, the group of authors (R.F. Akhmetov, T.B. Kutek, V.K. Shaverskiyi) created a modernized "facilitating-the-leadership" simulator, the technical characteristics of which are shown in Figure 1. The total length of the rail part of the training complex is 30 m. The I-beam number 10 was fixed to the metal fittings with the help of electric welding (1); the carriage was moving on the I-beam number 10 (2); the carriage consisted of two side frames. On the frames, we mounted carrying and guide rollers through which the carriage movement occurred with the restriction of its vibration in a horizontal plane during movement. Its frames also had suspension attachment hole (3). The frames were connected together by rollers.

The simulator complex had damping stops (7) located at the ends of the beams, for limiting the movement of the carriage and the prevention of athlete's stroke on the wall of the hall. The carriage is driven by an electric P42-type DC power motor (4) on the shaft 4.5 kW, supply voltage - 220 V and the frequency of revolution of the motor shaft - 1500 rpm through tensioning wires (5) and the rope, wound by the device (6). The engine had hard working characteristic mode, that is, the traction force was linearly dependent on the strength of current consumption.

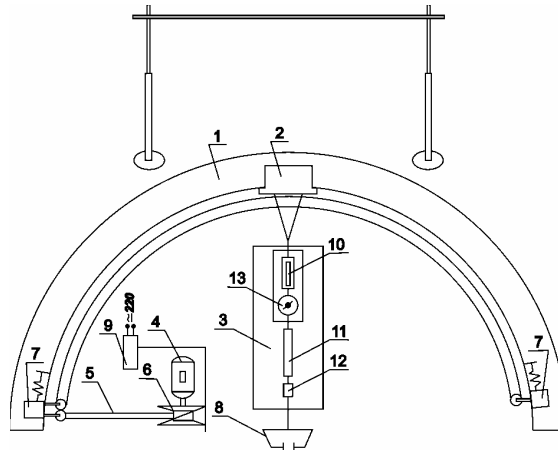

Fig. 1. Modernized "facilitating-the-leadership" simulator based on the monorail (scheme)

Suspension system (3) has been attached to the carriage. A lanyard (10) carried out adjusting of the value of a static "relief", rotation of which promptly changed the total length of the suspension system and the amount of "relief", according to individual needs of the athlete. Dynamometer (13) connected to a suspension system, allowed to control the amount of vertical force.

Reducing of the vertical load on the motor apparatus of a female athlete was carried out by introducing elastic elements into the suspension system (11).

Mounting of track and field athletes to the training complex was carried out using a special belt with the device (8), which was detachable (Fig. 2).

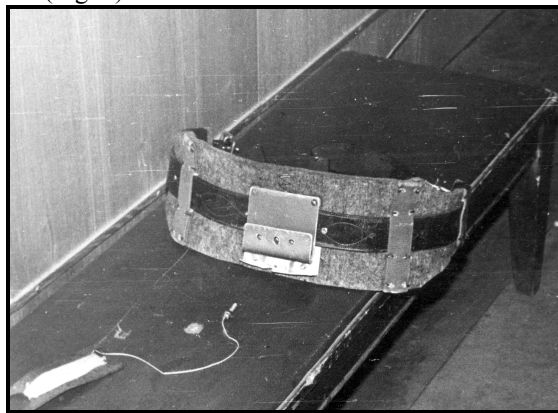

Fig. 2. General view of the belt with a detachable device

By using anchorages system, convenient for athletes, the vertical forces on the body were distributed evenly and did not interfere with the free takeoff at high speed.

The control unit performed increase or decrease of the carriage speed of movement. With the help of a rheostat, which was in the electric circuit control unit, the carriage speed along with running speed through its

associated suspension system were adjusted. Carriage speed (with slow regulation) was carried out in the range from 0 to 15 ms<sup>-1</sup>. To achieve the research objectives, the following methods were applied: analysis of scientific literature; study of accumulated experience in the management training of leading athletes, specializing in high jump; pedagogical experiment; instrumental techniques: electric podography and kinetic cyclography; methods of mathematical statistics. The study was conducted under the theme 2.11 "Theoretical and methodical bases of management of training system of athletes specializing in athletic jumps" of Unified Plan of research work in the field of physical education and sports for 2011-2015 – Ministry of Ukraine for Family, Youth and Sports (state registration number: 0111U003839).

**Results**

One of the major tasks facing this study was to identify ways to improve the structure of motor actions in the high jump with a running start in artificially created conditions which were provided by the use of the "facilitating the leading" simulator, built on the basis of the monorail. Skilled female athletes (masters of sports and international class masters of sports) took part in this research.

After an individual warm-up and test jumps over the bar, an athlete was offered to make three or four jumps at maximum height. Then the simulator was introduced to the athlete, and after a few test jumps, she continued performing jumps at maximum bar height again (three-four jumps). To determine the aftereffect, athletes did three to four jumps as high as possible after using the simulator. For the analysis of the material in all cases the best performance results of an attempt were used. Thus, this form of the experiment made it possible to evaluate the effect of the "facilitating-the-leadership" simulator and its aftereffects. Table 1 shows the data of a number of kinematic characteristics of the last three steps of the run, as they are the most significant for effectiveness of the high jump (R.F. Akhmetov, T.B. Kutek, V.K. Shaverskiyi).

Table 1. The influence of the "facilitating-the-leadership" simulator on kinematic characteristics of the three most recent run-up steps in the high jump of highly skilled female athletes

Kinematic characteristics	Steps of run	The third step			The penultimate step			The last step		
		B. D.	"F. L."	A.E.	B. D.	"F. L."	A.E.	B. D.	"F. L."	A.E.
The support time (ms)	M	150 100%	125-25%	140-6,7%	140 100%	100-2,41%	115-15,4%	120 - 100%	90-23%	100- 16,7%
	m	3.9	2.8	2.3	3.0	3.3	2.0	2.2	2.1	2.6
	σ	11.9	8.4	7.0	9.1	9.8	5.9	6.6	6.3	8.0
	V	7.9	7.0	5.0	7.0	9.6	5.3	5.5	7.0	8.0
	t	-	6.2	2.2	-	6.7	5.5	-	9.8	5.8
R	-	<0.001	<0.05	-	<0.001	<0.001	-	<0.001	<0.001	
Flight time (ms)	M	175 100%	185 + 5.5%	186-3,3%	135 100%	165 + 21.4%	155 + 14.2%	165 100%	165 ± 0%	175 + 5.8%
	m	3.2	2.6	3.1	3.6	2.5	3.9	3.0	2.3	2.9
	σ	9.8	8.0	9.4	10.8	7.7	11.9	9.1	7.0	8.8
	V	5.4	4.2	5.2	1.7	4.5	7.4	5.3	4.1	4.8
	t	-	2.4	1.3	-	6.8	3.7	-	-	2.3
R	-	<0.05	<0.5	-	<0.001	<0.01	-	-	<0.05	
Step time (ms)	M	325 100%	310-6,1%	326-3,1%	275 100%	265 ± 1,8%	270 ± 3,7%	285 100%	255-10,4%	275-3,5%
	m	3.7	2.8	2.3	3.7	2.8	3.1	3.3	3.7	2.1
	σ	11.2	8.4	7.0	11.2	8.4	9.4	9.8	11.2	6.3
	V	3.3	2.7	2.1	4.1	3.05	3.3	3.3	4.3	2.2
	t	-	4.3	2.3	-	1.07	2.07	-	6.06	2.6
R	-	<0.001	<0.05	-	<0.05	<0.05	-	<0.001	<0.05	
Length of step (cm)	M	205 100%	228 ± 11,4%	212 + 3,3%	217 100%	236 + 9,0%	222 + 2,3%	200 100%	206 + 8.5%	194 + 2,1%
	m	2.4	3.1	3.0	1.9	1.9	1.5	1.4	1.6	1.7
	σ	7.3	9.4	9.1	5.9	5.9	4.5	4.2	4.9	5.2
	V	3.6	4.2	4.3	2.7	2.5	2.0	2.2	2.4	2.7
	t	-	5.8	1.8	-	7.0	2.05	-	7.5	1.8
R	-	<0.001	<0.1	-	<0.001	<0.05	-	<0.001	<0.1	
Step speed (m / s)	M	6.3% 100	7.4 + 18%	6.7 + 6,5%	8.0% 100	8.7 + 8.9%	7.9 - 1.3%	6.6% 100	8.0 + 21,8%	7.1 + 7,8%
	m	0.02	0.03	0.02	0.02	0.03	0.04	0.03	0.03	0.03
	σ	0.08	0.1	0.08	0.08	0.01	0.12	0.1	0.1	0.1
	V	1.3	1.4	1.2	1.02	1.17	1.5	1.5	1.3	1.4
	t	-	30.0	13.3	-	17.5	2.2	-	3.5	12.5
R	-	<0.001	<0.001	-	<0.001	<0.05	-	<0.001	<0.001	
Pace	M	3.06 100%	3.24 + 5,9%	3.13 + 2,3%	3.1% 100	3.81 ± 0%	3.61 - 3,6%	3.44 - 100%	3.84 + 11,6%	3,57 ± 3,2%
	m	0.02	0.03	0.05	0.05	0.03	0.03	0.03	0.03	0.03
	σ	0.06	0.1	0.15	0.13	0.09	0.09	0.1	0.09	0.1
	V	1.98	3.1	4.8	3.5	2.4	2.5	2.9	2.3	2.8
	t	-	5.1	1.32	-	-	2.16	-	10.0	3.25
R	-	<0.001	<0.5	-	-	<0.05	-	<0.001	<0.01	

Abbreviations: B.D. - the basic data; "F. L."- Using "facilitating the leading" simulator; A.E. - aftereffect.

As we can see from Table 1, with each step of run-up, that is, the closer to the repulsion in normal conditions, the time of support and flight decreases, and the speed, step length and rate, on the contrary, increases. Noteworthy is the fact that the change of these characteristics has been uneven during the execution of the run. During this, the last step is essentially different from the previous one, especially in indicators such as step length, speed and pace.

When comparing the results obtained in normal conditions and in conditions of using "facilitating-the-leadership", the overall trend of change in kinematic characteristics during takeoff generally retained, but their change is more gradual in the real life setting and with higher rates of parameters such as the speed of the run, its pace, and a marked decrease in support time. The particularly significant restructuring in the kinematic characteristics under conditions of "facilitating-the-leadership" takes place in the last three steps of a run. This results in a reduction of time before the third step of repulsion by 25%, penultimate step - by 24.1% and the last step - by 23% compared with conventional conditions, which generally leads to a reduction in total duration of steps. In contrast to the usual conditions, where there is a reduction in the length of the last steps before repulsion, compared with the previous, and reduction of its pace, in terms of using "facilitating-the-leadership" the increase in the rate of the last step before repulsion by reducing its length is clearly seen. The use of the "facilitating-the-leadership" simulator positively indicated on the characteristics of the body flight. Thus, the angle of flight of the total body center of gravity increased by 15%, the rate of flight - 21%, and flight height - up to 30%, which led to an increase in performance in the high jump. To determine the aftereffect, the female athletes were offered to carry three to four jumps after removal of the facilitating "suspension", and then they had to perform the control jumps to the maximum height (three times). To analyze this, biomechanical characteristics of the best attempts were utilized. The research results signify that under such conditions there is a positive experience of the aftereffect. This is reflected in a reduction of time of support, some increase in the length and speed of steps during the run, which is especially noticeable in the last three steps before repulsion, compared with jumps, made prior to the use of "facilitating-the-leadership" simulator.

#### Discussion

Our research showed that the motor skill can be formed not in vivo, but under conditions specifically designed for this environment. In this case, the initial orientation of the target of improving the movement is to form a new rhythm-and-pace structure of motor skill up to the formation of a record regimen for a given athlete. This specially created artificial external environment gives the athlete power and energy additives necessary to compensate for the missing natural forces and capabilities. Trainer's task in using the "facilitating-the-leadership" simulator lies in a reasonable combination of natural motions and movements performed in vitro, with a subsequent reduction of artificial additives due to increasing the exercise capacity.

#### Conclusions

The aforementioned data suggests that the use of the "facilitating-the-leadership" simulator promotes a change in the biomechanical characteristics of movement and leads to a more rational use of the run in high jumping. Effective use of "facilitating-the-leadership" and its positive aftereffect is confirmed by the data obtained during mathematical analysis of the research results, indicating that the changes in all studied biomechanical characteristics have a statistically significant value, and, most importantly, the result of these changes is the shift of the angle of flight of the total body center of gravity at a larger height.

**Conflicts of interest** - Authors have no conflicts of interest to declare

#### References

- Akhmetov R.F. (2004). Simulator complexes in training highly qualified athletes in high jumping. *Pedagogy, psychology, medical-biological problems of physical education and sports*, vol. 1, 251-257.
- Akhmetov R.F. (2005). Theoretical and methodological bases of managing the long-term preparation of highly qualified athletes in high jumping: monograph. *Zhytomyr: Zhytomyr State I. Franko University*, 283.
- Bulatova M.M. (1996). Theoretical and methodological bases of realization of functional reserves of athletes in training and sports activities. *Dissertation of the Doctor of Pedagogical Sciences*, Kyiv, 50.
- Gamalii V.V. (2007). Biomechanical engineering aspects of sports motor actions. *Kyiv: Science World*, 212.
- Kutek T.B. (2011). Method of electrical stimulation of the muscles in the system of sports training of athletes. *Young Sports Science of Ukraine*, vol. 2, 141-147.
- Maksymenko G.N. (2007) Theoretical and methodical bases of preparation of young athletes. *Lugansk: Alma Mater*, 394.
- Platonov V.N (2004). Biomechanical ergogenic means in modern sports. *Science in the Olympic Sport Vol.2*, 96
- Platonov V.N. (2004). The system of training athletes in Olympic sports. The general theory and its practical applications: Student book of physical education and sport universities. *Kyiv: Olympic Literature*, 807.
- Popov G.I. (1992). Biomechanical basics for creation of the subject areas for the formation and perfection of movements. *Dissertation of the Doctor of Pedagogical Sciences, Moscow*, 626.
- Popov G.I. (2005). Biomechanical training technologies based on artificial control and substantive media. *Science in the Olympic Sport*, vol 2, 159-168.
- Shaverskiyi V.K. (2009). Biomechanical ergogenic agents in training students of specialty "Physical Education". *Young Sports Science of Ukraine*, 13(4), 204-208.