



## Electromagnetic tuning of resonant transmission in magnetoelastic metamaterials

Tatsunosuke Matsui, Mingkai Liu, David A. Powell, Ilya V. Shadrivov, and Yuri S. Kivshar

Citation: [Applied Physics Letters](#) **104**, 161117 (2014); doi: 10.1063/1.4873936

View online: <http://dx.doi.org/10.1063/1.4873936>

View Table of Contents: <http://scitation.aip.org/content/aip/journal/apl/104/16?ver=pdfcov>

Published by the [AIP Publishing](#)

---

### Articles you may be interested in

[Actively bias-controlled metamaterial to mimic and modulate electromagnetically induced transparency](#)

Appl. Phys. Lett. **104**, 261902 (2014); 10.1063/1.4886148

[Triple band polarization-independent ultra-thin metamaterial absorber using electric field-driven LC resonator](#)

J. Appl. Phys. **115**, 064508 (2014); 10.1063/1.4865273

[Adjustable low frequency and broadband metamaterial absorber based on magnetic rubber plate and cross resonator](#)

J. Appl. Phys. **115**, 064902 (2014); 10.1063/1.4863540

[Ultra-broadband electromagnetically induced transparency using tunable self-asymmetric planar metamaterials](#)

J. Appl. Phys. **114**, 163507 (2013); 10.1063/1.4826630

[Electromagnetic diode based on nonlinear electromagnetically induced transparency in metamaterials](#)

Appl. Phys. Lett. **103**, 091904 (2013); 10.1063/1.4819854

---



# Electromagnetic tuning of resonant transmission in magnetoelastic metamaterials

Tatsunosuke Matsui,<sup>1,2,a)</sup> Mingkai Liu,<sup>3</sup> David A. Powell,<sup>3</sup> Ilya V. Shadrivov,<sup>3</sup> and Yuri S. Kivshar<sup>3</sup>

<sup>1</sup>Department of Electrical and Electronic Engineering, Graduate School of Engineering, Mie University, 1577 Kurimamachiya, Tsu, Mie 514-8507, Japan

<sup>2</sup>The Center of Ultimate Technology on Nano-Electronics, Mie University, 1577 Kurimamachiya, Tsu, Mie 514-8507, Japan

<sup>3</sup>Nonlinear Physics Centre, Research School of Physical Sciences and Engineering, Australian National University, Canberra ACT 0200, Australia

(Received 26 March 2014; accepted 17 April 2014; published online 25 April 2014)

We demonstrate an analogue of electromagnetically-induced transparency (EIT) in a magnetoelastic metamaterial system and experimentally realize nonlinear electromagnetic tuning of this EIT-like transmission. We study a single meta-molecule, consisting of two split-ring resonators (SRRs) and one closed-ring resonator, with one SRR free to rotate about the common axis of the structure in response to torques induced by the microwave pump. We observe EIT-like narrow-band resonant transmission in the carefully optimized device, which we characterize in a microwave waveguide, and verify that the resonance is due to the hybridized mode of all three resonators. We demonstrate nonlinear spectral narrowing and an increase of the group delay upon increasing the pump power and show the significant role of the intrinsic rotation of the freely rotatable SRR in this process. © 2014 AIP Publishing LLC. [<http://dx.doi.org/10.1063/1.4873936>]

Since Pendry *et al.*<sup>1</sup> put forward the basic concept of metamaterials, numerous studies have been carried out to develop novel optical materials and devices such as artificial magnetic metamaterials, negative index materials, and optical cloaks.<sup>2–4</sup> In metamaterials, artificially designed subwavelength resonant elements (meta-atoms), such as the split-ring resonator (SRR), play crucial roles in obtaining a rich variety of unique responses to electromagnetic fields.<sup>1</sup> Recent research has broadened the concept of metamaterials considerably, enabling us to also access mechanical degrees of freedom with low power electromagnetic fields via near-field interaction between meta-atoms.<sup>5–15</sup> In the recently reported “magnetoelastic metamaterials” composed of meta-atoms and elastic materials, nonlinear bistable tuning of the resonant frequency was predicted.<sup>10</sup> In these systems, attractive interaction between closely-spaced SRRs is provided via the Ampere force acting between them due to the in-phase currents in the loops, and a restoring elastic Hooke force provides a feedback mechanism to stabilize the system. As an alternative to attractive interaction, rotational torque can be utilized. Liu *et al.* experimentally tuned the resonant response of metamaterials utilizing intrinsic rotation of a meta-atom about the common axis of a dimer.<sup>14,15</sup> The enhanced strength of the electromagnetic torque relative to the mechanical restoring torque allowed a strong bistable response to be observed in this system.

Here, we create narrow-band resonant transmission in tri-resonator magnetoelastic metamaterial structures, analogous to electromagnetically-induced transparency (EIT),<sup>16,17</sup> and demonstrate that it can be tuned by incident electromagnetic fields in the microwave frequency range. The EIT phenomenon was discovered in three level atomic systems and is

interpreted as a quantum interference effect. Recently, narrow-band transmission mimicking EIT has been obtained in various types of optical resonator systems, such as coupled resonators,<sup>18–20</sup> photonic crystals,<sup>21–23</sup> and metamaterials.<sup>24–29</sup> These systems are treated in the framework of classical electrodynamics and allow us to implement slow-light mechanism in various types of integrated optical systems and devices.<sup>30,31</sup> Our tri-resonator system consists of two SRRs and one closed-ring resonator (CRR) in which one of the SRRs is free to rotate in response to the incident electromagnetic field similar to the experiment reported by Liu *et al.*<sup>14</sup>

A schematic of the tri-resonator magnetoelastic metamaterial device is shown in Fig. 1 (the dielectric substrates are omitted for clarity). We use two copper (Cu) SRRs printed on Rogers R4003 dielectric substrates. The inner radius, track width, slit width, and thickness of each SRR are 3.2 mm, 1.0 mm, 0.2 mm, and 0.035 mm, respectively. The dielectric constant and loss tangent of the dielectric substrate are 3.5 and 0.0027, and its thickness is 0.5 mm. The lower SRR (SRR<sub>l</sub>) is fixed, but the upper SRR (SRR<sub>u</sub>) is suspended with a thin rubber wire and is free to rotate about the common axis. Azimuthal rotation is the only allowed degree of freedom. A rectangular CRR made from Cu wire is placed such that the two SRRs and the CRR are aligned approximately coaxially and SRR<sub>l</sub> and the CRR are placed in the same layer. The length and the width of the rectangular CRR are carefully designed to obtain EIT-like narrow-band transmission, and are around 27.8 mm and 12.5 mm, respectively. The horizontal position and the initial twist angle of SRR<sub>u</sub> are also carefully adjusted. The tri-resonator device is placed such that the common axis of the device is well aligned along the center axis of a rectangular waveguide for the microwave transmission measurement. A schematic of the experimental setup for the microwave pump-probe measurement is shown in Fig. 2. The device is placed in the center of

<sup>a)</sup>Author to whom correspondence should be addressed. Electronic mail: matsui@elec.mie-u.ac.jp

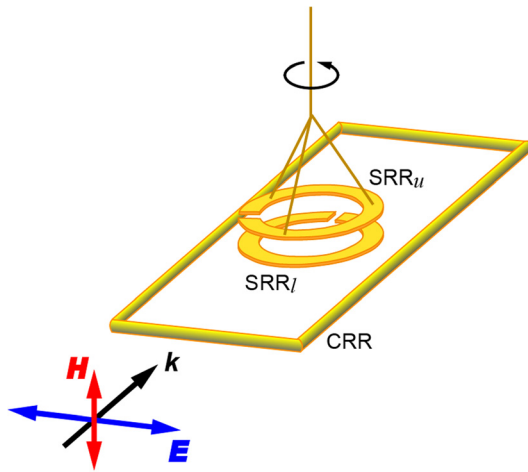

FIG. 1. Schematic representation of the tri-resonator magnetoelastic metamaterial device. The CRR and lower SRR ( $SRR_l$ ) are fixed to the dielectric substrate. The upper SRR ( $SRR_u$ ) is suspended by a thin rubber wire and is free to rotate about the common axis. The directions of the incident electric ( $E$ ) and magnetic ( $H$ ) fields and wavevector ( $k$ ) are also shown.

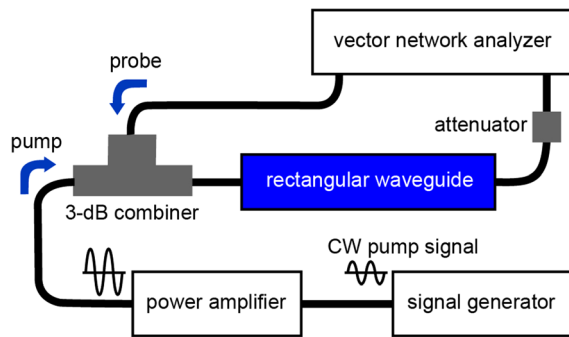

FIG. 2. Schematic of the microwave pump-probe measurement setup. The CW pump signal from a signal generator is amplified by a power amplifier and sent into the waveguide containing the structure. The transmission spectra are measured using a vector network analyzer.

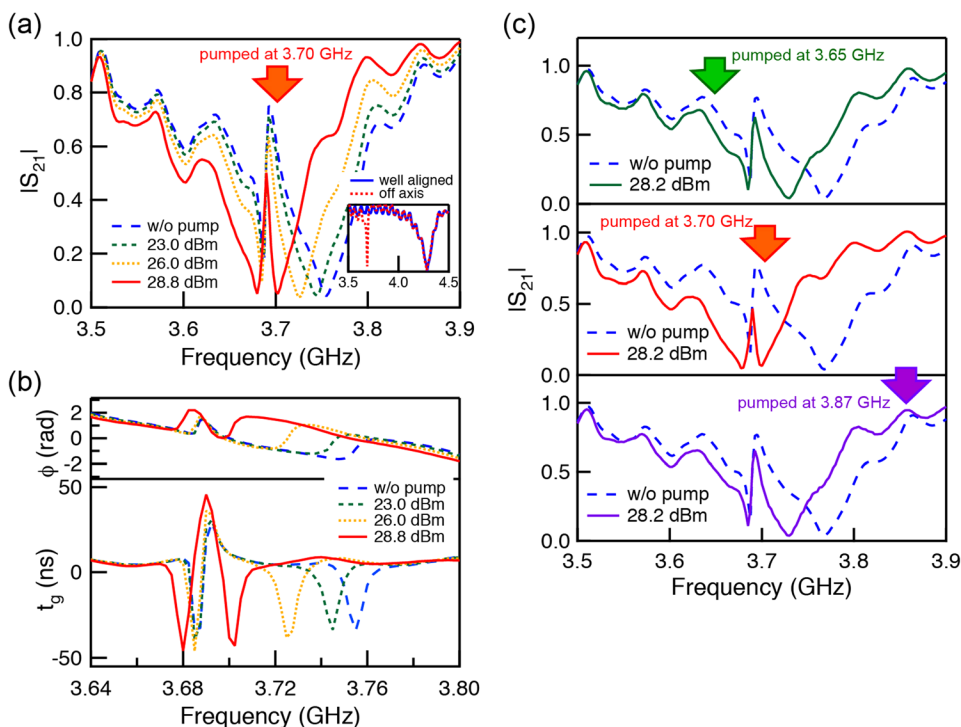

FIG. 3. Summary of the microwave pump-probe experiments. (a) Measured transmission coefficients of the tri-resonator magnetoelastic metamaterial. The system is pumped with a CW signal at 3.70 GHz. Inset: Measured transmission coefficients of the CRR. (b) Phase  $\phi$  of measured transmission coefficients of the tri-resonator magnetoelastic metamaterial and retrieved group delay  $t_g$ . The system is pumped with a CW signal at 3.70 GHz. (c) Measured transmission coefficients of the tri-resonator magnetoelastic metamaterial pumped by a CW signal with frequencies of 3.65, 3.70, and 3.87 GHz.

a WR229 rectangular waveguide, in which only the fundamental ( $TE_{01}$ ) mode can be supported in the frequency range of interest. The direction of wave propagation ( $k$ ) and polarization ( $E$  and  $H$ ) of the microwave pump and probe signals impinging on the tri-resonator device are indicated in Fig. 1. The CW pump signal from a signal generator (HP 8673B) is amplified by a power amplifier (HP 83020A) and fed into the waveguide. The transmission spectra are measured using a vector network analyzer (Rohde and Schwarz ZVB-20). Each time the pump power level is adjusted, the system is allowed to reach mechanical steady state before the transmission of the probe wave is recorded. Detailed information on the experimental procedures for the device fabrication and the microwave pump-probe measurements can be found in Ref. 14.

In Fig. 3(a), the measured transmission coefficients of the tri-resonator device placed in the waveguide are presented. The frequency of the pumping CW signal is adjusted near the EIT-like transmission peak (3.70 GHz), and the pump power dependent transmission spectra are recorded. In a well-adjusted tri-resonator system of two SRRs and one CRR, an EIT-like narrow-band transmission window with central frequency of 3.690 GHz appears in the middle of the wider bandwidth transmission dip.  $SRR_u$  is initially placed such that the mode matching is slightly off such that it gives a weak (wider) EIT-like response without pumping. Upon increasing the pump power, the bandwidth of the EIT-like transmission is significantly narrowed. Since the  $SRR_u$  is the only element allowed to rotate in response to the pump electromagnetic (EM) field, it must play a significant role in this spectral narrowing. However, the frequency of the EIT-like transmission peak does not shift much upon the change of pump power, which implies that the freely rotatable  $SRR_u$  has little contribution to determining the resonant frequency of the EIT-like narrow-band transmission. In the inset of Fig. 3(a), the measured transmission spectra of a single CRR



are shown. Relatively wide-band and narrow-band transmission dips are seen at 4.279 GHz and 3.688 GHz, respectively. The sharp dip at 3.688 GHz matches quite well with the EIT-like narrow-band transmission frequency in the tri-resonator system; however, this mode can only be excited when the CRR is placed *asymmetrically* within the waveguide. The long edges of the CRR are orthogonal to the incident electric field ( $\mathbf{E}$ ) of the incident electromagnetic fields, and the dipole-like mode along them can only be excited when the symmetry of the system is broken. Thus, this sharp dip at 3.688 GHz could be attributed to the resonance with the dipole-like “dark” mode along the long edges of the CRR, and may play a significant role in obtaining the EIT-like narrow-band transmission. It is well known that the EIT-like narrow-band transmission gives larger dispersion in the group index and significantly slows down the speed of light.<sup>16,17</sup> In Fig. 3(b), the phase ( $\phi$ ) of the measured transmission coefficients and retrieved group delay ( $t_g = -d\phi/d\omega$ ) are shown. At around 3.690 GHz where the EIT-like narrow-band transmission window appears, the group delay significantly increases (more than 50%) upon increasing the pump power and reaches  $\sim 46$  ns. Our results suggest that magneto-elastic metamaterials allow us to access not only the mechanical degrees of freedom but also the time-domain responses of the system and can be utilized to fabricate tunable slow light devices. In Fig. 3(c), the measured transmission coefficients are shown for the tri-resonator device placed in the waveguide, pumped with CW signals of frequencies 3.65, 3.70, and 3.87 GHz. The system can be driven with a CW microwave pump signal ranging from 3.65 up to 3.87 GHz; however, pumping near the EIT-like transmission peak frequency  $\sim 3.70$  GHz gives the best narrowing of the EIT-like transmission window.

In order to understand better how this EIT-like mode originates, we have performed numerical analysis using the commercial 3D electromagnetic simulation package, CST Microwave Studio. In Fig. 4, the transmission spectra of the tri-resonator system are presented for the changing angle of  $SRR_u$  simulated in a waveguide configuration analogous to that in the experiment. In the inset of Fig. 4, the angle between the two SRRs  $\theta$  is shown (the CRR and dielectric substrates are omitted for clarity). Upon rotating  $SRR_u$ , the relatively wide-band transmission dip shows a red-shift, and

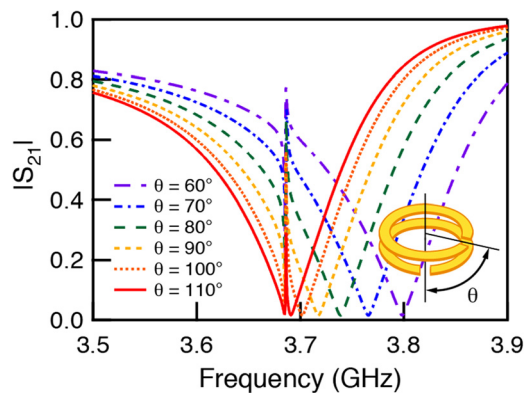

FIG. 4. Numerically simulated transmission coefficients of the tri-resonator device with different twist angles  $\theta$ , quantifying the rotation of  $SRR_u$  with respect to  $SRR_l$  about the common axis.

the bandwidth of the EIT-like narrow-band transmission becomes much narrower, which reproduces the experimentally obtained results shown in Fig. 3(a) quite well. This supports our previous supposition that the tuning mechanism of the EIT-like response is provided via intrinsic rotation of  $SRR_u$  responding to the pumping electromagnetic field. However, the EIT-like narrow-band transmission can be obtained only when the CRR is either positioned slightly off axis of the waveguide or rotated, and in our simulation, CRR is translated 0.5 mm in a lateral direction with respect to  $SRR_u$ . This suggests that an inevitable contribution from misalignment in the real experiment is essential in obtaining the EIT-like response in our system.

Figure 5 shows the spatial distribution of the electric field amplitude  $|E|$  at the frequencies corresponding to the second lowest transmission dip close to the EIT-like peak at 3.685 GHz (A), the EIT-like narrow-band transmission peak at 3.686 GHz (B), and the minimum of the transmission dip at 3.718 GHz (C).  $SRR_u$  is rotated  $90^\circ$  about the common axis with respect to  $SRR_l$ . The upper three panels were obtained in the plane of the upper SRR, and the lower three panels were obtained in the common plane in which both the CRR and  $SRR_l$  are placed. At the frequency corresponding to the minimum of the transmission dip (C), it can be seen that a strong enhancement of the electric field is obtained within the capacitive gaps of the two SRRs, and there is a dipole-like electric

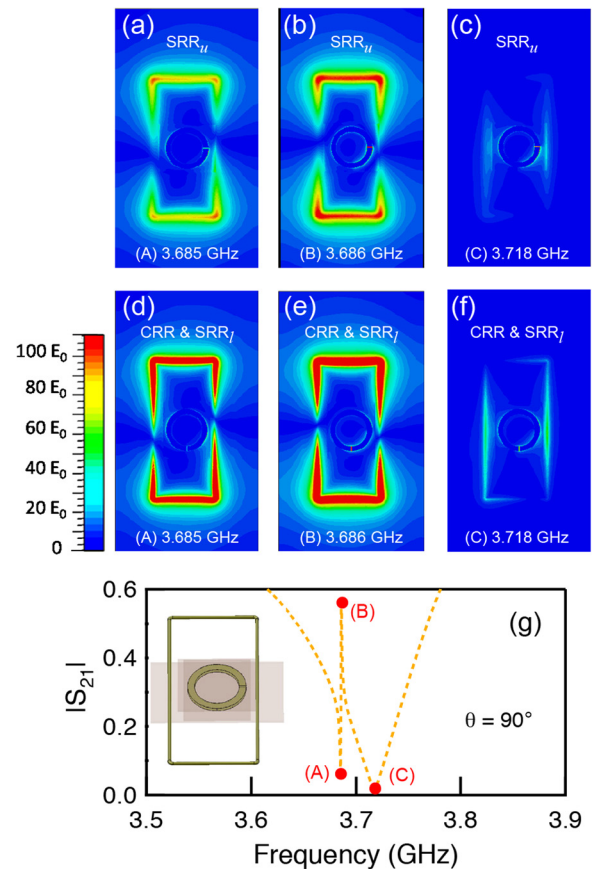

FIG. 5. Numerically simulated electric field  $|E|$  at frequencies of (A) 3.685 GHz, (B) 3.686 GHz, and (C) 3.718 GHz, indicated in the bottom panel (g).  $SRR_u$  is rotated  $90^\circ$  with respect to  $SRR_l$ . The electric field amplitude  $|E|$  is normalized to the incident field  $E_0$ . The upper three panels (a)–(c) are obtained in the layer where  $SRR_u$  is placed, and the lower three panels (d)–(f) are obtained in the layer where the CRR and  $SRR_l$  are placed.

field pattern along the short edges of the CRR. By examining the current flow and the field pattern, we confirm that this relatively wide-band transmission dip is attributed to the hybridization of the symmetric mode of SRR pair<sup>9</sup> (currents flow in the same direction), and the electric resonance along the *short* edges of the CRR. The electromagnetic field-induced red-shift is initiated via rotation of SRR<sub>*u*</sub> (twist angle  $\theta$  enlarges), similar to the experiment by Liu *et al.*<sup>14</sup> At the frequency of the second lowest transmission dip (A), only the dipole-like mode along the *long* edges of the CRR is strongly excited. At a slightly higher frequency where the EIT-like narrow-band transmission is obtained (B), strong enhancement of the electric field can be recognized at both the capacitive gap of the two SRRs and along the long edges of the CRR. This implies that the EIT-like narrow-band transmission is attributed to the hybridized mode of all three resonators. Therefore, the EM field-induced spectral narrowing should be attributed to the better mode matching between the above two modes, namely, the symmetric hybridized mode of the coupled pair of SRRs and the narrow-band dipole-like mode along the long edge of the CRR, induced by the intrinsic rotation of the freely rotatable SRR<sub>*u*</sub>.

In conclusion, we have demonstrated experimentally the transmission characteristics of a tri-resonator metamaterial system consisting of two SRRs and one CRR under different CW pumping conditions using a microwave pump-probe experiment. One of the SRRs is free to rotate about the common axis of the structure in response to the electromagnetic pump wave. We have realized the EIT-like narrow-band resonant transmission in the carefully optimized device and observed significant spectral narrowing when increasing the pump power. The retrieved group delay at EIT-like transmission window significantly increases and suggests that our tri-resonator magneto-elastic metamaterial can be utilized to fabricate tunable slow light devices. We have numerically verified that the EIT-like narrow-band transmission is attributable to the hybridized mode of all three coupled resonators. We have shown that the electromagnetic field-induced spectral narrowing of the EIT-like narrow-band transmission is due to mode matching between the symmetric hybridized mode of the coupled SRR pair and the narrow-band dipole-like mode of the long edges of the CRR. We have achieved the tuning of the bandwidth of the EIT-like narrow-band transmission by utilizing the intrinsic rotation of freely rotatable SRR induced by the near-field interaction between SRRs. Our findings suggest a concept for the application of magnetoelastic metamaterials to tunable slow light devices. While the demonstrated microwave sample has a slow non-linear response, we expect that the principle can be applied in to develop optical structures, where large tunability of the slow light band is of great importance. A possible approach to achieve this is via DNA origami structures.<sup>32,33</sup>

This work was financially supported by Australian Research Council. T.M. acknowledges funding from the TEPCO Memorial Foundation.

- <sup>1</sup>J. B. Pendry, A. J. Holden, D. J. Robbins, and W. J. Stewart, *IEEE Trans. Microwave Theor. Tech.* **47**, 2075 (1999).
- <sup>2</sup>V. M. Shalaev, *Nat. Photonics* **1**, 41 (2007).
- <sup>3</sup>C. M. Soukoulis, S. Linden, and M. Wegener, *Science* **315**, 47 (2007).
- <sup>4</sup>N. I. Zheludev and Y. S. Kivshar, *Nature Mater.* **11**, 917 (2012).
- <sup>5</sup>S. V. Perminov, V. P. Drachev, and S. G. Rautian, *Opt. Lett.* **33**, 2998 (2008).
- <sup>6</sup>R. Zhao, P. Tassin, T. Koschny, and C. M. Soukoulis, *Opt. Express* **18**, 25665 (2010).
- <sup>7</sup>D. A. Powell, M. Lapine, M. V. Gorkunov, I. V. Shadrivov, and Y. S. Kivshar, *Phys. Rev. B* **82**, 155128 (2010).
- <sup>8</sup>M. Lapine, I. V. Shadrivov, D. A. Powell, and Y. S. Kivshar, *Sci. Rep.* **1**, 138 (2011).
- <sup>9</sup>D. A. Powell, K. Hannam, I. V. Shadrivov, and Y. S. Kivshar, *Phys. Rev. B* **83**, 235420 (2011).
- <sup>10</sup>M. Lapine, I. V. Shadrivov, D. A. Powell, and Y. S. Kivshar, *Nature Mater.* **11**, 30 (2012).
- <sup>11</sup>M. Lapine, I. Shadrivov, and Y. Kivshar, *Sci. Rep.* **2**, 412 (2012).
- <sup>12</sup>M. Liu, D. A. Powell, and I. V. Shadrivov, *Appl. Phys. Lett.* **101**, 031105 (2012).
- <sup>13</sup>J. Zhang, K. F. MacDonald, and N. I. Zheludev, *Phys. Rev. B* **85**, 205123 (2012).
- <sup>14</sup>M. Liu, Y. Sun, D. A. Powell, I. V. Shadrivov, M. Lapine, R. C. McPhedran, and Y. S. Kivshar, *Phys. Rev. B* **87**, 235126 (2013).
- <sup>15</sup>M. Liu, D. A. Powell, I. V. Shadrivov, M. Lapine, and Y. S. Kivshar, *New J. Phys.* **15**, 073036 (2013).
- <sup>16</sup>S. E. Harris, *Phys. Today* **50**(7), 36 (1997).
- <sup>17</sup>L. V. Hau, S. E. Harris, Z. Dutton, and C. H. Behroozi, *Nature* **397**, 594 (1999).
- <sup>18</sup>D. D. Smith, H. Chang, K. A. Fuller, A. T. Rosenberger, and R. W. Boyd, *Phys. Rev. A* **69**, 063804 (2004).
- <sup>19</sup>A. Naweed, G. Farca, S. I. Shopova, and A. T. Rosenberger, *Phys. Rev. A* **71**, 043804 (2005).
- <sup>20</sup>Q. Xu, S. Sandhu, M. L. Povinelli, J. Shukya, S. Fan, and M. Lipson, *Phys. Rev. Lett.* **96**, 123901 (2006).
- <sup>21</sup>M. F. Yanik, W. Suh, Z. Wang, and S. Fan, *Phys. Rev. Lett.* **93**, 233903 (2004).
- <sup>22</sup>S. F. Mingaleev, A. E. Miroshnichenko, Y. S. Kivshar, and K. Busch, *Phys. Rev. E* **74**, 046603 (2006).
- <sup>23</sup>S. F. Mingaleev, A. E. Miroshnichenko, and Y. S. Kivshar, *Opt. Express* **16**, 11647 (2008).
- <sup>24</sup>S. Zhang, D. A. Genov, Y. Wang, M. Liu, and X. Zhang, *Phys. Rev. Lett.* **101**, 047401 (2008).
- <sup>25</sup>N. Papisimakis, V. A. Fedotov, N. I. Zheludev, and S. L. Prosvirnin, *Phys. Rev. Lett.* **101**, 253903 (2008).
- <sup>26</sup>N. Liu, L. Langguth, T. Weiss, J. Kästel, M. Fleischhauer, T. Pfau, and H. Giessen, *Nature Mater.* **8**, 758 (2009).
- <sup>27</sup>S.-Y. Chiam, R. Singh, C. Rockstuhl, F. Lederer, W. Zhang, and A. A. Bettiol, *Phys. Rev. B* **80**, 153103 (2009).
- <sup>28</sup>P. Tassin, L. Zhang, T. Koschny, E. N. Economou, and C. M. Soukoulis, *Opt. Express* **17**, 5595 (2009).
- <sup>29</sup>J. Gu, R. Singh, X. Liu, X. Zhang, Y. Ma, S. Zhang, S. A. Maier, Z. Tian, A. K. Azad, H.-T. Chen, A. J. Taylor, J. Han, and W. Zhang, *Nature Commun.* **3**, 1151 (2012).
- <sup>30</sup>T. Baba, *Nat. Photonics* **2**, 465 (2008).
- <sup>31</sup>A. E. Miroshnichenko, S. Flach, and Y. S. Kivshar, *Rev. Mod. Phys.* **82**, 2257 (2010).
- <sup>32</sup>P. W. K. Rothmund, *Nature* **440**, 297 (2006).
- <sup>33</sup>A. Kuzyk, R. Schreiber, Z. Fan, G. Pardatscher, E.-M. Roller, A. Hoge, F. C. Simmel, A. O. Govorov, and T. Liedl, *Nature* **483**, 311 (2012).