



Open Research Online

The Open University's repository of research publications and other research outputs

Numerical modelling of microwave sintering of lunar simulants under near lunar atmospheric condition

Conference or Workshop Item

How to cite:

Lim, S.; Levin Prabhu, V.; Anand, M.; Bowen, J.; Morse, A. and Holland, A. (2018). Numerical modelling of microwave sintering of lunar simulants under near lunar atmospheric condition. In: European Lunar Symposium (ELS) 2018, 13-16 May 2018, Toulouse, France.

For guidance on citations see [FAQs](#).

© [not recorded]

Version: Version of Record

Copyright and Moral Rights for the articles on this site are retained by the individual authors and/or other copyright owners. For more information on Open Research Online's [data policy](#) on reuse of materials please consult the policies page.

oro.open.ac.uk

NUMERICAL MODELLING OF MICROWAVE SINTERING OF LUNAR SIMULANTS UNDER NEAR LUNAR ATMOSPHERIC CONDITION. S. Lim¹ (sungwoo.lim@open.ac.uk), V. L. Prabhu¹, M. Anand^{1,2}, J. Bowen³, A. Morse¹, and A. Holland¹, ¹School of Physical Sciences, The Open University, UK, ²Department of Earth Sciences, The Natural History Museum, London, UK, ³School of Engineering and Innovation, The Open University, UK

Introduction: The Space Instrumentation Group at The Open University has recently started investigating microwave sintering of lunar regolith/simulant as a potential fabrication method of 3D printing on the Moon to build lunar habitats. As part of this initiative, we have designed an industrial bespoke microwave heating apparatus. This apparatus will allow thorough experimental investigation of the sintering mechanism of lunar regolith/simulant in the cavity. The mechanical properties of sintered specimens produced under optimal conditions can then be explored. The experiment will also be validated using COMSOL Multiphysics simulation software.

In this contribution, we discuss the current design of the bespoke microwave heating apparatus, and how COMSOL has been employed to understand the different characteristics of lunar simulants when subjected to microwave heating.

Microwave sintering: Microwave sintering of lunar regolith as a potential fabrication method of lunar habitat construction has become one of the popular topics in recent years [1]. Previous research in this area, however, have been conducted using domestic microwaves. Figure 1 shows our initial work setting (see companion abstract by Levin-Prabhu et al. in this meeting).



Figure 1: Microwave sintering using a kitchen microwave

The picture on the left shows an infrared thermometer setting for measuring the surface temperature of specimen, the middle and right pictures show the sintered/melted lunar simulant JSC-1A. Domestic kitchen microwaves are not ideal for sintering lunar simulants for the following reasons: (i) they are not capable to withstand temperatures of up to 1,250 °C – the melting point of lunar regolith/simulant; (ii) they are not optimised to maximise microwave energy into a single hotspot; (iii) they are not able to mimic lunar atmospheric condition; (iv) it is not possible to measure sample surface temperature accurately; and (v) the frequency is fixed at 2.45 GHz which is an optimal frequency

to heat water molecules in food products but may not be optimal for inorganic solid materials such as lunar regolith.

Thus, an industrial bespoke microwave heating apparatus has been designed to overcome the current limitations. Figure 2 illustrates a design of the apparatus which includes two ports for an infrared thermometer probe and an endoscope-type digital camera, one naked-eye viewer window, and a cylindrical cavity with a flange for a vacuum pump. The ports can also be connected to a mass spectrometer, permitting extraction and analysis of volatiles while specimens are heated. Volatiles in regolith can be extracted by heating the regolith between 300 and 900 °C [2, 3]. For example, temperature of 700 °C is sufficient to obtain most of the H₂ and He [4]. Thus, the apparatus could also be used for measuring the types and amount of volatiles which could be used for propellant and life support (e.g. water). It is expected that the new apparatus would allow to (i) maximise microwave energy in a single hotspot; (ii) measure the surface temperature and phase change of specimens under near lunar atmospheric condition with more accuracy; and (iii) heating specimens of lunar simulant rapidly to be sintered/melted. This first version of apparatus does not support multiple frequencies, however, this feature is planned to be added in a future upgrade.

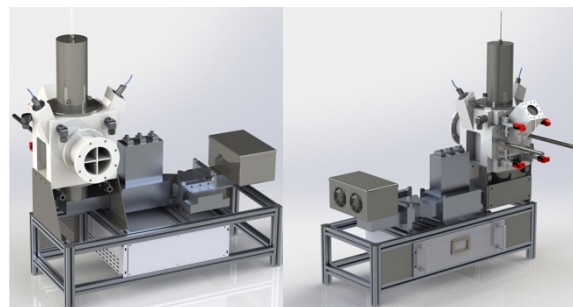

Figure 2: Industrial bespoke microwave heating apparatus

Numerical Modelling: While the actual experiment will be conducted as soon as the apparatus is installed in our lab, the experiment can also be simulated with a numerical modelling method. We have chosen COMSOL Multiphysics software (version 5.3a) [5] which has been used previously for a similar purpose [6]. COMSOL requires various parameters of material characteristics to simulate mi-

crowave heating phenomenon. Most parameters of lunar simulants have been identified, e.g., Table 1 shows the required material properties of JSC-1A for COMSOL simulation.

Table 1: Minimal material parameters of JSC-1A needed for COMSOL simulation [6]

Thermal conductivity	k	$0.35 \text{ W/m} \times \text{K}$
Specific Heat	C_p	$0.85 \text{ KJ/Kg} \times \text{K}$
Density	ρ	1.66 g/cm^3
Electrical conductivity	σ	0 S/m
Permittivity	$\epsilon' - \epsilon'' \times j$	$4 - 0.1j$
Permeability	$\mu' - \mu'' \times j$	$1 - 0.01j$

Initially, it was assumed that nanophase iron (np-Fe⁰) is key to facilitate microwave heating of lunar regolith [7], but later some experiments [8] revealed that np-Fe⁰ does not play a major role in microwave heating of lunar regolith under low magnetic field conditions and room temperature. The experiment led to another finding that the existing lunar simulants have larger absorption caused by their dielectric properties rather than magnetic properties at room temperature [9] although the finding still needs to be validated at higher temperatures.

All existing experiments, however, do not report the dielectric properties of each simulant as a function of temperature. Ideally, it would be best if we have these properties from cryogenic to the melting point of test materials in order to fully mimic the onsite fabrication on the lunar surface. As a starting point, we are measuring the dielectric properties of two lunar simulants JSC-1A and NU-LHT-3M and some powdered lunar meteorites from room temperature to 600, 800 and 950 °C; more temperature steps could be added depending upon the initial results guided by the available time and resources. The bulk density of JSC-1A powder was measured as 1.65~1.66 g/cm³ in [6, 9], however, we are making compacted pellets of simulants for which the bulk density of JSC-1A is around 2.07 g/cm³, obtained through our initial measurement of dielectric property of JSC-1A. Thus, the same value will be used for simulation.

Discussion:

Currently, we are creating a virtual cavity of the bespoke microwave apparatus in a COMSOL environment in order to conduct simulations of microwave heating in vacuum cavity with different materials, density, temperature and frequencies. With the identified full set of material data, we will be able to model more thorough mechanism of microwave heating of lunar simulant under near lunar atmospheric condition. Expected findings from the planned numerical modelling are (i) verifying the

bespoke design of the cavity that could maximise microwave energy to heat specimens; (ii) understanding the sequence of sintering phenomenon by continual simulation of the surface and internal temperature of specimens; and (iii) identifying the different effects of sintering among frequencies in terms of the time and penetration depth.

The Open University has established three Strategic Research Areas (SRA) one of which is Space. This has enabled us to integrate our existing expertise in 3D Concrete Printing [10, 11] and knowledge of lunar science and ISRU potential on the Moon [2] to perform a series of microwave sintering experiments aiming to develop a potential fabrication method of an extra-terrestrial construction process.

Acknowledgement: The authors acknowledge funding from the Open University's Space SRA.

References:

- [1] Lim, S., Prabhu V.L., Anand, M. and Taylor, L. (2017) *Adv. in Space Research J.*, 60(7), 1413-1429. [2] Anand, M., et al. (2012). *Planet. and Space Sci.*, 74(1), 42-48. [3] Ethridge, E. and Kaukler, W. (2012). *Concepts and Approaches for Mars Exploration*. [4] Crawford, I. (2015). *Progress in Physical Geography*, 39, 137-167. [5] <http://www.comsol.com>. [6] Ethridge, E. and Kaukler, W. (2012) *50th AIAA Aerospace Sci. Meeting*, AIAA2012-0801. [7] Taylor, L.A. and Meek, T.T. (2005). *J. of Aerospace Eng.* 18(3), 188-196. [8] Barmatz, M.B., et al. (2011). *42nd Lunar and Planetary Sci. Conf.*, LPI. [9] Barmatz, M.B. et al. (2012). *43rd Lunar and Planet. Sci. Conf.*, LPI. [10] Lim, S., et al. (2016). *Additive Manufacturing*, 12(B), 216-230. [11] Lim, S., et al. (2012). *Automation in Construction*, 21(1), 262-268.