



**Universidade de Aveiro**  
**2010**

Departamento de Electrónica,  
Telecomunicações e Informática (DETI)

**Andreia Juliana Alves Redes ópticas passivas de próxima geração  
(NG-PON)**

**Next generation passive optical networks  
(NG-PON)**





**Andreia Juliana Alves** **Redes ópticas passivas de próxima geração  
(NG-PON)**

**Next generation passive optical networks  
(NG-PON)**

Dissertação apresentada à Universidade de Aveiro para cumprimento dos requisitos necessários à obtenção do grau de Mestre em Engenharia Electrónica e Telecomunicações, realizada sob a orientação científica do Dr. António Teixeira e do Dr. Mário Lima, ambos do Departamento de Electrónica, Telecomunicações e Informática e do Instituto de Telecomunicações da Universidade de Aveiro.



Dedico este trabalho aos meus pais, irmãs e namorado, por todo o apoio prestado ao longo do meu percurso.



**o júri**

presidente

Doutor Paulo Miguel Nepomuceno Pereira Monteiro  
Professor Associado da Universidade de Aveiro

Orientador      Doutor António Luís Jesus Teixeira  
Professor Auxiliar da Universidade de Aveiro

Co-orientador    Doutor Mário José Neves de Lima  
Professor Auxiliar da Universidade de Aveiro

Vogal    Jorge Costa de Sousa e Castro  
Investigador Senior do INESC Porto





## **agradecimentos**

Este trabalho representa um marco final no percurso académico. Sem a participação directa ou indirecta de algumas pessoas, teria sido mais complicado atingir esta meta. Em primeiro lugar quero agradecer especialmente aos meus pais, irmãs e família por toda a ajuda ao longo dos anos, toda a compreensão e apoio, e por me ajudarem a descontraír e manter os meus objectivos. Agradeço também ao meu namorado Gabriel, toda a ajuda prestada ao longo do meu percurso académico tanto a nível pessoal como a nível profissional. Pela oportunidade e orientação imprescindível agradeço aos orientadores deste projecto o Prof. Doutor António Luís Jesus Teixeira e Prof. Doutor Mário José Neves de Lima.

Por todos os bons anos que passei nesta universidade, agradeço á instituição pelo óptimo acolhimento e ensino prestado.



**acknowledgment**

This work represents a milestone in the academic journey. Without the direct or indirect involvement of some people, it would have been harder to achieve this goal. First let me thank especially to my parents, sisters and family for all their help over the years, the comprehension and support, and for helping me relax and keep my goals. I also thank my boyfriend Gabriel, for the help provided throughout my academic journey both personally and professionally. For the opportunities and supervision I would like to thank the supervisors of this project Prof. António Luís Jesus Teixeira and Prof. Mário José Neves de Lima. For all the good years I have spent in this university, special thanks to the institution for the excellent care and education provided.



**palavras-chave**

Redes passivas de próxima geração, requisitos, standard, desempenho, ITU, IEEE, 802, G-PON, XG-PON

**resumo**

As redes ópticas passivas (PONs) prometem satisfazer os requisitos dos utilizadores e provedores de serviços de forma a obter débitos mais elevados, quando comparados com as tecnologias baseadas em cobre. Com este trabalho pretende-se estudar e apresentar as tecnologias PON correntes actualmente, as suas características principais e alguma interpretação de como estas conseguem satisfazer os requisitos impostos.

Vários standards para PON têm vindo a ser desenvolvidos ao longo dos anos e, considerando que a necessidade de melhores características de serviço é contínua, surgiram as redes ópticas passivas de próxima geração. As NG-PONs prometem satisfazer as exigências dos novos serviços, garantindo melhor qualidade de serviço global que os seus antecessores.

Neste trabalho as recomendações do ITU-T e do IEEE são estudadas e apresentadas em detalhe e, como corolário, são comparadas por forma a identificar as suas diferenças e semelhanças.

Com base nos conhecimentos obtidos, e com o intuito de validar por simulação alguns dos limites impostos pelas normas são feitas várias simulações de uma rede PON, seguindo a norma 10G-EPON. São variados parâmetros como distância da fibra, número máximo de utilizadores e perdas máximas por inserção de forma a poder avaliar o seu efeito e enquadrar com a norma obtida.



**keywords**

Passive Optical Network, requirements, standard, performance

**abstract**

Passive Optical networks (PONs) promise to overcome the requirements of users and service providers to achieve higher data rates than conventional copper Technologies. This work study and present the actual PON technologies, their main features and how they can successfully fulfill the imposed requirements.

Several PON recommendations have appeared all over the years and due to ever increasing demand of improved services, PON networks evolved to Next Generation Passive Optical Networks. NG-PONs come to respond to the new quality and demanding services, ensuring better global performance than their antecessors.

The ITU-T and IEEE recommendations are studied and presented in detail, and by corollary are compared in order to easily comprehend the differences and similarities between them.

Based on the knowledge obtained and with the aim of validate by simulation some of the boundaries imposed by the recommendations, several simulations of a PON network are performed, following the 10G-EPON standard. Parameters like, fiber distance, number of users and maximum insertion loss are changed to evaluate their impact in the PON performance and to frame them in the recommendation.





# Table of Contents

List of Figures .....	i
List of Table .....	iii
List of Symbols .....	vii
Chapter 1. Introduction.....	1
1.2. Structure and objectives .....	4
1.3. Main contributions .....	5
1.4. Motivations for this new technology .....	6
Chapter 2. Standardization .....	7
2.1. Context .....	7
Chapter 3. Status of PON deployment.....	11
3.1. Previous and present status of PON .....	11
3.1.2. Description of EPON main features .....	14
3.1.3. Description of G-PON main features .....	17
3.1.4. Description of 10GE-PON main features .....	23
3.2. General comparison of parameters.....	25
3.2.1 G-PON vs. EPON.....	25
3.2.2 10G-EPON vs. EPON .....	28
3.3. Opening and space for the XG-PON.....	30
Chapter 4. Main features of XG-PON1 .....	32
4.1. Network architecture .....	32
4.2. Migration scenarios .....	34
4.3. Service Requirements.....	35
4.3.1. Services .....	35
4.3.2. Qos and traffic management.....	36
4.4. Physical layer requirements .....	36
4.4.1. Optical wavelength.....	36
4.4.2. Bit rates .....	37
4.4.3. Optical power budget .....	37

4.4.4. Split ratio .....	37
4.4.5. Fiber distance .....	37
4.5. System level requirements.....	37
4.5.1. Dynamic bandwidth Assignment (DBA) .....	38
4.6. Operational requirements .....	38
4.6.1. Resilience and protection ODN.....	38
4.7. Framing .....	39
4.7.1 Downstream frame .....	39
BWmap fields are summarized in the following table: .....	41
4.7.2 Upstream frame .....	41
4.8. General comparison of parameters .....	42
4.8.1 G-PON vs. XG-PON.....	42
4.8.2 XG-PON vs.10G-EPON.....	43
Chapter 5. 10G-EPON Simulations.....	46
5.1. Introduction .....	46
5.2. Setup description .....	46
5.3. Results .....	50
5.3.1. Loss analysis .....	50
5.3.2. Temperature analysis.....	53
5.3.3. 10G/1G-EPON coexistence.....	54
5.4. Conclusion.....	56
Chapter 6. Conclusions and future work .....	58
6.1 Conclusions .....	58
6.2 Future work .....	60
References .....	63

## List of Figures

**Figure 2.1:** Standardization timeline for next-generation 10G-class PON systems [Kani, 2009].

**Figure 3.1:** Breakdown of the FTTx technologies worldwide – end of 2008 [IDATE, 2009].

**Figure 3.2:** FTTx technologies worldwide [Alveirinho, 2009].

**Figure 3.3:** Example of tree configuration [Kramer, 2004].

**Figure 3.4:** EPON Downstream and Upstream transmission [Kramer, 2004].

**Figure 3.5:** Downstream Transmission in G-PON section [Redesign, 2009].

**Figure 3.6:** Upstream Transmission in G-PON section [Redesign, 2009].

**Figure 3.7:** G-PON Downstream frame [G.984.3, 2008].

**Figure 3.8:** G-PON Downstream frame [G.984.3, 2008].

**Figure 3.9:** G-PON Downstream frame (BW map) [G.984.3, 2008].

**Figure 3.10:** G-PON GEM frame [G.984.3, 2008].

**Figure 3.11:** G-PON Upstream frame [G.984.3, 2008].

**Figure 4.1:** XG-PON architecture [Kunigonis, 2008].

**Figure 4.2:** XG-PON use cases [FSAN, 2009].

**Figure 4.3:** FTTB architecture [Kunigonis, 2008].

**Figure 4.4:** Downstream XGTC frame [G.987.3, 2010].

**Figure 4.5:** XGTC physical control block downstream (PCBd) [G.987.3, 2010].

**Figure 4.6:** Lend field [G.987.3, 2010].

**Figure 4.7:** XGTC bandwidth map allocation structure [G.987.3, 2010].

**Figure 4.8:** XGTC layer upstream overhead XGTC bandwidth map allocation structure [G.987.3, 2010].

**Figure 5.1:** 10G-EPON main setup, with 1:N splitting ratio.

**Figure 5.2:** 10G-EPON OLT.

**Figure 5.3:** 10G-EPON ONU.

**Figure 5.4:** BER Vs. Loss (Low power budget class).

**Figure 5.5:** BER Vs. Loss (Medium power budget class).

**Figure 5.6:** BER Vs. Loss (High power budget class).

**Figure 5.7:** BER Vs. Temperature.

**Figure 5.8:** BER Vs. Loss (Coexistence scenario).

# List of Table

**Table 3.1:** Main features EPON [802.3ah, 2008].

**Table 3.2:** Main features G-PON [G.984.1, 2008].

**Table 3.3:** G-PON Downstream frame [G.984.3, 2008].

**Table 3.4:** G-PON Downstream frame [G.984.3, 2008].

**Table 3.5:** G-PON GEM frame [G.984.3, 2008].

**Table 3.6:** G-PON Upstream frame [G.984.3, 2008].

**Table 3.7:** 10G-EPON main features [802.3av, 2009].

**Table 3.8:** G-PON Vs. EPON main features.

**Table 3.9:** 10G-EPON vs. EPON main features.

**Table 4.1:** XGTC bandwidth map allocation structure [G.987.3, 2010].

**Table 4.2:** G-PON vs. XG-PON main features.

**Table 4.3:** XG-PON vs. 10G-EPON main features.

**Table 5.1:** Components specifications.

**Table 5.2:** Sensitivity resume.

**Table 5.3:** Variation on sensitivity resume.

## List of Acronyms

<b>APON</b>	Asynchronous Passive Optical Network
<b>ASE</b>	Amplifier Spontaneous Emission
<b>ATDM</b>	Asynchronous Time Division Multiplexing
<b>ATM</b>	Asynchronous Transfer Mode
<b>BER</b>	Bit Error Rate
<b>BPON</b>	Broadband Passive Optical Network
<b>CAPEX</b>	Capital Expenditure
<b>CO</b>	Central Office
<b>CSMA-CD</b>	Carrier Sense Multiple Access – Collision Detection
<b>DBA</b>	Distributed Bandwidth Allocation
<b>DFB</b>	Distribution Feed-Back
<b>DS</b>	Downstream Signal
<b>DSL</b>	Digital Subscriber Line
<b>EFM</b>	Ethernet in the First Mile
<b>EPON</b>	Ethernet Passive Optical Network
<b>FSAN</b>	Full Service Access Network
<b>FTTH</b>	Fiber to the Home
<b>FTTP</b>	Fiber to the Premise
<b>GEM</b>	G-PON Encapsulation Method
<b>G-PON</b>	Gigabit Passive Optical Network
<b>Gigabit PON</b>	Generic term to represent both G-PON and 1G-EPON
<b>IEEE</b>	Institute of Electrical and Electronics Engineers
<b>IL</b>	Insertion Loss
<b>IP</b>	Internet Protocol
<b>IPTV</b>	Internet Protocol Television

<b>ISDN</b>	Integrated Services Digital Network
<b>ISP</b>	Internet Service Provider
<b>LAN</b>	Local Area Network
<b>MAC</b>	Media Access Control
<b>MAN</b>	Metropolitan Area Network
<b>NF</b>	Noise Figure
<b>MPCP</b>	Multi-Point Control Protocol
<b>NGN</b>	Next-Generation Networks
<b>NG-PON</b>	Next Generation Passive Optical Network
<b>NG-EPON</b>	Next Generation Ethernet Passive Optical Network
<b>NRZ</b>	Non Return to Zero
<b>OAM</b>	Operation, Administration, Maintenance
<b>ODN</b>	Optical Distribution Network
<b>OEO</b>	Optic-Electric-Optic
<b>OLT</b>	Optical Line Terminal
<b>OMCI</b>	ONT Management Control Interface
<b>ONT</b>	Optical Network Termination
<b>ONU</b>	Optical Network Unit
<b>OPEX</b>	Operational Expenditure
<b>PB</b>	Power Budget
<b>PLOAM</b>	Physical Layer Operation Administration and Management
<b>PMD</b>	Physical Medium Dependent
<b>PON</b>	Passive Optical Network
<b>POTS</b>	Plain Old Telephone Service
<b>PSTN</b>	Public Switched Telephone Network

<b>QoS</b>	Quality of Service
<b>SDO</b>	Standard Deployment Organization
<b>SMF</b>	Single Mode Fiber
<b>SOA</b>	Semiconductor Optical Amplifier
<b>SONET</b>	Synchronous Optical Network
<b>TC</b>	Transmission Convergence
<b>TDM</b>	Time Division Multiplexing
<b>TDMA</b>	Time Division Multiple Access
<b>UNI</b>	User Network Interface
<b>VoIP</b>	Voice over Internet Protocol
<b>VPN</b>	Virtual Private Network
<b>US</b>	Upstream Signal
<b>WAN</b>	World Area Network
<b>WDM</b>	Wavelength Division Multiplexer
<b>WBF</b>	Wavelength Blocking Filter
<b>XG-PON</b>	10-Gigabit-capable Passive Optical Networks
<b>XG-PON1</b>	XG-PON supporting 2.5 Gbit/s upstream and 10 Gbit/s downstream line rates
<b>XG-PON2</b>	XG-PON supporting 10 Gbit/s symmetric line rates



# List of Symbols

${}^4I_{11/2}$	Pump Band
${}^4I_{13/2}$	Metastable Band
${}^4I_{15/2}$	Ground State Band
$B_e$	Electrical Filter Bandwidth
$B_o$	Optical Filter Bandwidth
$C$	Constant fiber scattering depending on constituents of fiber core
$\Delta\nu$	Resolution Bandwidth of the Optical Spectrum Analyzer
$E_0$	Ground State Band Energy
$E_1$	Metastable Band Energy
$E_2$	Pump Band Energy
$Er^{3+}$	Erbium Ion
$f_{DRS}$	Fraction of signal power double Rayleigh Scattered
$F_n$	Noise Figure
$G$	Signal Gain
$G(z)$	Raman Gain
$h$	Planck Constant
$K$	Users splitting ratio
$L$	Erbium Doped Fiber Length
$L_{EX}$	Coupling excess losses
$L_S$	Fiber losses, Insertion loss and Equipment filtering
$L_T$	Total losses
$M$	Number of wavelengths
$N$	Number of Remote Nodes
$N_1$	Population Density in Ground State Band
$N_2$	Population Density in Metastable Band
$N_{shot}$	Shot Noise
$n_{sp}$	Spontaneous Emission factor
$N_{SP-SP}$	Spontaneous-Spontaneous Noise
$N_{S-SP}$	Signal to Spontaneous Noise Power

$P_0$	Initial Power Launched in the fiber
$P_{ASE}$	Amplified Spontaneous Emission Optical Power
$P_{in}$	Input Power of Optical Signal
$P_p$	Input pump power
$P_p^{sat}$	Saturation pump power
$P_s$	Upstream signal power
$R$	Photodetector Responsivity
$r_s$	Rayleigh Scattering Coefficient
$S$	Recapture coefficient
$U$	Number of users
$\nu$	Frequency
$x$	Couling drop factor
$y$	Couling pass factor
$z$	Distance
$\alpha$	Attenuation coefficient
$\alpha_R$	Scattering Losses
$\alpha_s$	Scattering coefficient
$\Gamma_s$	Confinement Factor
$\lambda$	Signal wavelength
$\mu$	Inversion Population factor
$\rho_{ASE}$	Amplified Spontaneous Emission spectral density
$\sigma_{RB}^2$	Variance of detected Rayleigh Backscattering
$\sigma_{RB-RB}^2$	Variance of the interference of the RB noise with itself
$\sigma_{SIG-RB}^2$	Variance of the signal RB interference
$\sigma_T^2$	Variance of the thermal noise
$\sigma_s^a$	Absorption Cross Section
$\sigma_s^e$	Emission Cross Section

# Chapter 1. Introduction

## 1.1. Context

The telecommunication industry never stops both in progressing and keeping the steady increasing demand for bandwidth, all of this mostly fuelled by streaming and multimedia applications. This trend highlights the interests in deploying and operating cost-efficient broadband access networks. Cost efficiency is determined by the simplicity of the technology (affecting installation, operation and maintenance costs) and scalability. Wireless communications are a good alternative for fast effective deployments with typically low cost implementations, however due to the constraints and costs of operational licenses for radio spectrum and limitations in speed/autonomy, this technology cannot compete against optical communications in terms of available bandwidth, latency and robustness. It is the common belief that optical access networks are capable of meeting those requirements for present and future applications.

Cable operators and telecommunication carriers are always competing for customers and, today's winners as well as others for a very long time, are those who built their infrastructure and are using it to deliver broadband services. There is a continuous struggle on how to balance infrastructure investments against the need to deliver stronger financial returns, and, for what was said, selecting the ideal solutions for access networks is a major challenge. Optical fiber access connectivity affords a whole new opportunity for services providers to invest and capture the next-generation Broadband consumer wave.

The ideal solution should also target delivering bundled voice, data, and video services (also called triple-play services) to an end-user subscriber over a single network. Today, many alternatives exist for upgrading the existing access network to broadband such as digital subscriber line (DSL), cable TV networks and most recently PON networks [ORPHANOUDAKIS, 2007].

A Passive Optical Network (PON) is a single, shared optical fiber that uses inexpensive optical splitters to divide the single fiber connection coming from the network access point into separate strands feeding individual subscribers. PONs are called "passive" due to the fact that there are no active electronics within the access network.

In order to achieve cost effective solutions for PON networks, present investigations are centered in access networks which mainly use passive optical components to avoid the use of power sources and costly control equipment between the central office (Optical Line Termination OLT) and the user premises (Optical Network Unit ONU). The ONU has a direct impact in the cost capital expenditures (CAPEX) per customer, that is the amount used during to acquire or improve long term assets [Ma, 2003].

PON networks are characterized by offering more bandwidth available, improvements in the quality of the service and immunity to noise and interference.

The increased interest in PON technology as an attracting solution for the deployment of efficient broadband access networks is reflected by recent standards introduced by the full service access network (FSAN) group of ITU-T and the Ethernet in the first mile (EFM) group of IEEE which cover PON solutions operating at gigabit rates. Both can efficiently transport packet-based traffic avoiding the cell tax, paid by ATM-based PON systems.

BPON (Broadband Passive Optical Network) and EPON (Ethernet Passive Optical Network) have been deployed on a large scale in many networks around the world. G-PON (Gigabit Passive Optical Network) [ORPHANOUDAKIS, 2007], standard was developed with a frame format that can transmit variable length packets efficiently at gigabit per second rates. Starting to be a very versatile standard, G-PON has higher

transmission speed than BPON and EPON. FSAN placed emphasis on the ability of a gigabit PON (G-PON) system to support all service needs with any quality of service (QoS) demand and high efficiency, which makes this PON more complex. It adopts fixed periodic framing accommodating TDM and ATM needs [Angelopoulos, 2004], so that services with very strict requirements can be serviced at the right moment, temporarily interrupting data packets, hence the need for fragmentation. The PON architecture, allows traffic from different customer terminations, which are grouped in optical network units (ONUs), to be multiplexed using TDMA (time division multiple access) under the arbitration of the MAC (medium access control) protocol in the upstream direction. The user-network interfaces are implemented in the ONUs, which may lie at the customer curb, building or even home, serving one or more users.

Access control is exercised by the OLT (optical line termination) at the root of the tree, which lies in the central office. These are the bases of the PON systems.

IEEE standard (EPON) distinguishes its self from G-PON by using the Ethernet stack, therefore, the service provided by EPON is Ethernet. This lets you utilize the economies-of-scale of Ethernet, and provides simple, easy-to-manage connectivity to Ethernet-based, IP equipment, both at the customer premises and at the central office. EPON uses the Multi-Point Control Protocol (MPCP), which employs REPORT (an upstream message from the ONU) and GATE (a downstream message from the OLT) control messages, to request and assign transmission opportunities on the PON. This is the basic mechanism that controls the flow of data on the PON, and it used by higher level functions for bandwidth allocation, ONU synchronization, and ranging.

However, already have been several years since standardization of this access is around. Recently, the IP distribution of land-based digital television and the video distribution of multi channel have been provided for the broadband subscribers. Considering these trends, it is anticipated that the gigabit bandwidth G-PON and EPON are not enough to accommodate the close future applications. So, the next generation of PON systems are required to provide faster speed are strongly expected.

In response to these needs, recently new standards from either ITU-T or IEEE came up. Clearly, both standardization groups felt the necessity of defining faster network

data rates to meet the requirements of the new services available. More users per PON and higher fiber distance are also requirements for these new standards. Both 10G-EPON and XG-PON offer these advantages.

XG-PON and 10G-EPON belong to the next generation of passive optical networks (NG-PON). These new standards both show improvements from the previous ones and take into consideration the upgrade path, therefore the compatibility between them and its legacy versions. These considerations are to make sure that upgrades are simple and do not require the revision of the entire network. The similarities and differences between the (EPON, G-PON, 10G-EPON and XG-PON) standards are several. When the PON standardization efforts started there was an interest to get compatibility between the IEEE standards and the ITU-T standards, but due to the different interests of the two groups and their different requirements, several incompatibilities in the finished standards were present.

The recent standards, XG-PON from June 2010 and the 10G-EPON from September 2009, offer ten times the bandwidth available in the current EPON and G-PON, higher splitting ratio, higher power budget, among other advantages.

## 1.2. Structure and objectives

This work is organized in six chapters, with the objective to describe, compare and simulate PON technologies.

Chapter one observes Passive Optical Networks as a possible technology to be the successor of the copper based technologies. It also gives a general description of deployed PONs and their functionalities.

In chapter two is explained the PON standardization evolution and the necessity of its context evolution, due to all the existing requirements.

Chapter three describes the state of PON deployment over the world and also in Portugal. Also, are presented the main features of EPON, G-PON and 10G-EPON, as well as a comparison between them.

The fourth chapter explains the most recent standard of ITU-T (XG-PON), allowing to understand its main features. In order to be able of relate this standard with those presented previously, a comparison between them is also presented.

In the fifth chapter, several characteristics which directly affect PON performance are evaluated. With variation of features like fiber distance, splitting ratio and maximum insertion loss is possible to understand how they can affect the transmitted signal and how this can be improved.

Finally, in chapter six, the conclusions of this work are presented. Also, possible future in PON technologies is pointed out.

### 1.3. Main contributions

The main contributions of this work are:

- Compact summary of the main evolutionary steps in PON standardization and the requirements that lead to the Next Generation of Passive Optical Networks.
- Comprehensive summary of past and present state of art in the PON deployment worldwide.
- Simplified version of PON Standards and their successors, through an analysis of their main features.
- Summarizing the similarities and differences of the standards towards the compatibility or otherwise incompatibility between them.
- Providing an analysis of the main features impact in the PON performance. Validating the limitation factors that decrease the quality of the transmitted signal and also how to compensate this deteriorating effect.

## 1.4. Motivations for this new technology

Is nowadays common sense to consider that broadband access is a necessary ingredient for economic success. In response to the steady increasing demand for bandwidth and networking services for residential users as well as enterprise customers, passive optical networks (PONs) have emerged as a promising access technology that offers flexibility, broad area coverage and cost-effective sharing of the expensive optical links compared with the conventional point-to-point (P2P) transport solutions.

Today's service providers are faced with unstoppable bandwidth demand and higher split ratios. NG-PON1 promises to dominate the access market by offering a bandwidth boost. With higher split ratios, NG-PON1 is emerging on cue to deal with challenges in delivering high-speed, high-bandwidth packaged services. At the same time customers are not willing to pay for an increased bandwidth of the network. Therefore, there is a strong need of cost-effective solutions to provide an access to the online world which satisfies both of the most interested parts consumers and operators. With a little thoughtful planning, service providers can ensure their network is capable of a smooth, cost-effective migration to NG-PON and future PON technologies.



## Chapter 2. Standardization

### 2.1. Context

Communication has always been an issue of interest for the human being, and it really was taken to the next level with the emergence of internet. It did not take a long time to evolve from the Public Switched Telephone Network (PSTN), to the Digital subscriber line (DSL), cable modem technologies and most recently to the fiber based optical access.

Nowadays an enormous part of the world depends on the internet services either for work, communication, or entertainment. Passive optical networks (PONs) were believed to be the one of the best solution, for the new requirements that came up, as pointed in chapter one.

With PONs tasks like installation, provisioning, maintenance and troubleshooting are simplified. They provide abundance of bandwidth and can be integrated smoothly into both the central office equipment and the outside plant. PONs first application date from the 1980's, representing a cost effective method of sharing fiber infrastructure for narrowband telephony (TPON) to business premises [CIP, 2006].

PON standardization work began in 1990's when carriers anticipated fast growth in bandwidth demands. The real push to the PON standardization was taken when

the necessity to lower the cost of optical access systems and create a reliable economic solution appeared. To accomplish this main goal FSAN group was created.

FSAN (Full Access Network) group is constituted by a set of people belonging to the major operators in the world and service providers that contribute to the development of an interoperability standard (communication between different equipments of different companies). This committee of people came in 1995, with the interest of finding a solution for complete access of voice, data and video. At that time, it was believed that the best PON technology was based on ATM (Asynchronous Transfer Mode), with the FSAN group it was possible to create the ITU-T standard for APON (ITU-T G.983- Broadband optical access systems based on Passive Optical Networks -PON).

FSAN mission is directed to the creation of applicable standards, simultaneously to allow technologic advances toward new applications for Passive Optical Networks (PON) and to contribute for other technologies besides PON. It's important to underline that FSAN is not an organization responsible to define standards. Their concern is with the contributions given by the Companies that are members of FSAN and what they can bring to facilitate the development of global PON standards.

The entity that is responsible for the standardization is ITU-T (Telecommunication standardization sector), which is part of the International Telecommunications Unit (ITU), responsible for coordinating standardizations related with telecommunications.

In the present ITU-T is an intergovernmental agency which clusters more than 700 public and private organizations over 191 countries.

The international standards produced by ITU-T are known as Recommendations, and are organized by series of Recommendation. The ITU-T standards are more recognized than similar international organizations because ITU-T is a United Nations specialized agency. Telecommunications sector divide their work in categories and Recommendation are numbered inside each serial.

Basically FSAN joins the information and organizes meetings to develop the important issues and ITU-T gets that information and forms the international standard.

With the evolution of PON technologies, standardization experts concluded that APON did not have significant cost advantages against new access-oriented SONET (Synchronous Optical Network) based platforms. So the need for improvements was clear and APON standard evolved to BPON (Broadband PON). The name BPON was introduced since the name APON led people to assume that only ATM services could be provided to end users. Changing the name to BPON reflected in the fact that BPON systems offer broadband services including Ethernet access, video distribution, and high-speed leased line services. BPON was prompted by recommendations of FSAN which were later adopted by ITU as additions to the ITU-T G.983 series. These standards specified 622 Mb/s DS, and 155Mb/s or 622Mb/s aggregate US data rates [G.983.1, 2005]. Each OLT is shared by up to 32 ONUs for a maximum separation of 20 km between the OLT and ONU. BPONs use TDM (Time Division Multiplexing) for multiple access and ATM cells for data framing. Therefore, some professionals continue to refer to BPON as APON.

The G.983.3 standard specifies duplex wavelength division on a single fiber with the 1.3 $\mu$ m wavelength window for upstream transmission and the 1.49 $\mu$ m window for downstream.

In March 2001, another approach was taken by the IEEE. The 802.3ah Ethernet in the First Mile (EFM) project was started. The objective was to standardize the transport of Ethernet frames on PONs. In contrast to the approach of FSAN/ITU, the IEEE prefers a technology-driven development philosophy.

The IEEE (Institute of Electrical and Electronics Engineers) describes itself as "the world's largest technical professional society -- promoting the development and application of electrotechnology and allied sciences for the benefit of humanity, the advancement of the profession, and the well-being of our members."

The outcome of the IEEE effort was EPON, the IEEE 802.3ah EPON standard was ratified in June 2004. At almost the same time that IEEE was working on EPON, FSAN/ITU-T was also working in another standard G-PON (G.984) and they left us with a situation where the world has two major PON standard systems: EPON, which is based on Ethernet frame transmission and G-PON, which is based on GEM fragment transmission.

G-PON has enhanced capability comparing with APON and BPON and is backward compatible. G.984 standard series define the general characteristics of G-PON (G.984.1) as well as physical layer specification (G.984.2), transmission layer specification (G.984.3) and ONU (Optical Network Unit) management and control specification (G.984.4).

Besides the fact that these standards are two gigabit capable PONs, this is not enough to respond to the increasing appetite for more bandwidth and while the current major deployment of passive optical network (PON) systems in the world uses Gigabit-class PON systems such as Gigabit Ethernet PON (EPON) and Gigabit-capable PON (G-PON), standardization work groups are preparing 10 Gigabit-class PON systems for the next generation.

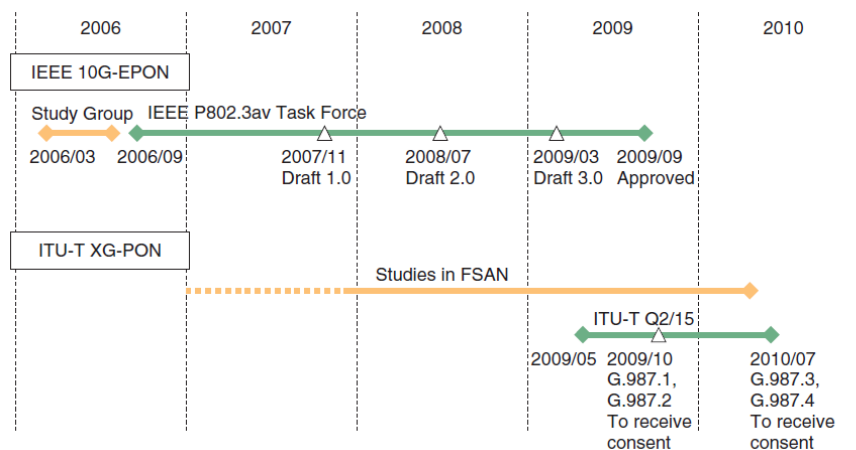

Figure 2.1: Standardization timeline for next-generation 10G-class PON systems [Kani, 2009].

In September 2009, the IEEE organization released the 802.3av standard (10G-EPON), while ITU-T was deploying the G.987.x series of recommendations. As expected, ratification of the relevant standards has provided the gating factor for the timing of 10-Gbps PON system development. The IEEE reached its initial ratification milestone first, completing IEEE Std. 802.3av-2009, “Physical Layer Specifications and Management Parameters for 10Gbit/s Passive Optical Networks,” last September and commercially available systems compliant to the standard quickly followed. The Full Service Access Network Initiative (FSAN) and ITU-T are expected to catch up soon when they release their XG-PON specifications, like is shown in Figure (2.1). Again, carriers can expect their suppliers will have commercially available XG-PON systems soon after this milestone.

## Chapter 3. Status of PON deployment

### 3.1. Previous and present status of PON

As state before with FSAN formed in the mid-1990s the first PON activity was established. The group's major objective was to define a common standard for PON equipment so that vendors and operators could come together in a competitive market for PON equipment. The first series of standards were ITU-TG.983, which were renamed BPON and used ATM as its transport protocol (known as the APON protocol).

Nowadays Passive optical networks are intensively being deployed in the Asia Pacific region. Japanese service providers are deploying passive optical networks since 2002, initially with BPON and then with EPON. 2007 reports of Japan's Ministry of Internal Affairs shows that Japanese service providers were providing fiber-to-the-home (FTTH) connectivity to 5.0 million subscribers. The EPON activity initiated in 2001, when the IEEE established the Ethernet in the First Mile (EFM) group. The EFM group was responsible for the approbation of a standard with a bit rate up to 1.25Gbit/s, improving the bit rate existing at the time with BPON, they also provided the possibility of a symmetric bit rate for Ethernet transport only.

Apart from the need to support higher bit rates, the overall protocols have been opened for reconsideration considering that the solutions should be optimized and efficient in terms of support for multiple services, operation, administration, maintenance (OAM)

functionality and scalability. As a result of the FSAN effort, a new solution has emerged in the optical access market place – Gigabit PON (G-PON), offering unprecedented high bit rate support while enabling the transport of multiple services, specifically data and TDM in native formats and with extremely high efficiency. Gigabit Passive Optical Network (G-PON) is defined by ITU-T recommendation series G.984.1 through G.984.4. G-PON and EPON systems are intrinsically incompatible, and the market has evolved to deploy the two systems on a geographically diverse basis.

EPON is mostly deployed in Asia Pacific and G-PON is especially deployed in USA and Europe. Although EPON represents 60% of the FTTH deployments over the world, like is represented in Figure (3.1) G-PON is winning presence in Europe, North America and is becoming the technology of choice in the thriving Chinese market as well [IDATE, 2009].

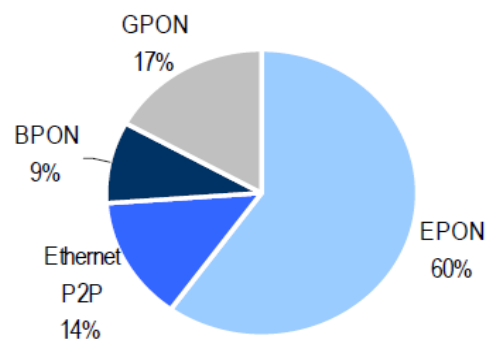

Figure 3.1: Breakdown of the FTTH technologies worldwide – end of 2008 [IDATE, 2009].

Portugal is winning place in the PON market, that nationally has three major players in the FTTH deployment which are Portugal Telecom (FTTH G-PON), Sonaecom (FTTH G-PON) and ZON (FTTLA as well as FTTB GEPON) [HELSEN, 2010]. With all the deployment made in the pass years Portugal made its entry in the Global Ranking.

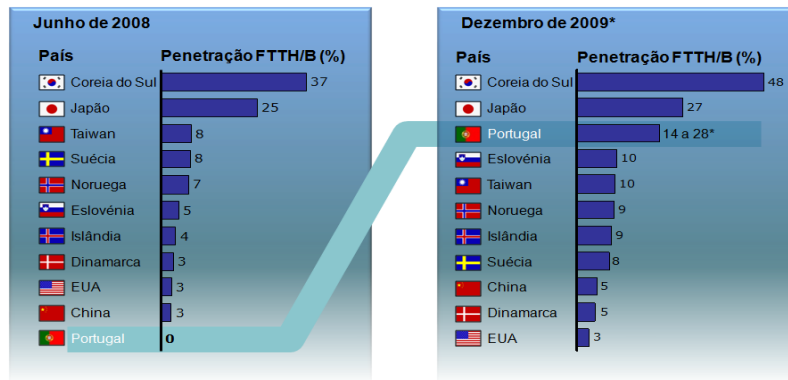

Figure 3.2: FTTx technologies worldwide [Alveirinho, 2009].

For next-generation PON systems, targets include the captivation of FTTH subscribers such as high-end users, business users and multifamily-housing users and the provision of bandwidth-guaranteed services and high-definition video services, among others. Due to these needs for more bandwidth, XG-PON (G.987.x) from ITU-T and 10G-EPON (802.3av) from IEEE emerge to solve these requirements. 10G-EPON offers a tenfold leap in bandwidth to 10Gbit/s in the broadband access network over fiber while providing core protocol compatibility with current EPON solutions. Like G-PON, XG-PON offers a great variety of services and is also compatible with the existing G-PON technology. As stated 10G-EPON is already implemented and G.987.x series of recommendations for G-PON are expected to be ready at July of 2010. Yet, just because technology is available doesn't mean it will be adopted quickly [Kani, 2009].

The next step in PON systems will be the implementation of WDM-PONs, which is already being study and some vendors already have working equipments. Future Wavelength Division Multiplexed PON (WDM-PON) are systems, where each ONU is served by a single wavelength, that will allow increasing the network capacity and will simplify the network management as all the connections are point-to-point. In addition, the implementation of colorless ONUs will allow for centralized wavelength management, introducing further architectural simplification and cost savings.

### 3.1.2. Description of EPON main features

Passive optical networks (PONs) provide a powerful point-to-multipoint solution to satisfy the increasing capacity demand in the access part of the communication infrastructure, between service provider central offices (COs) and customer sites. A PON consists of an optical line terminal (OLT) located at the provider CO and a number of optical network units (ONUs) at the customer premises. In a time-division multiplex (TDM) PON downstream traffic is handled by broadcasts from the OLT to all connected ONUs, while in the upstream direction an arbitration mechanism is required so that only a single ONU is allowed to transmit data at a given point in time because of the shared upstream channel. The start time and length of each transmission time slot for each ONU is scheduled using a bandwidth allocation scheme.

IEEE, through the activities of Ethernet in the first mile (EFM) 802.3ah group, has standardized a Gigabit Ethernet-friendly technology, called Ethernet PON (EPON) with the objective to leverage the great success of Ethernet as a LAN technology and exploit the economies of scale that the dominance of Ethernet has generated. The objective of EFM efforts has been to combine a minimal set of extensions to the IEEE 802.3 media access control (MAC) and MAC control sub-layers with a family of physical (PHY) layers. In addition, a mechanism for network operations, administration and maintenance (OAM) is included to facilitate network operation and troubleshooting.

The tree-shaped topology of PONs is the result of passive splitting of fibers extending from the OLT that represents the ‘root’ and reaching multiple optical network termination units (ONUs) that represent the ‘leaves’ of the tree. This architecture also results in the broadcast operation in the downstream direction, while in the upstream channel an aggregate data flow is generated by means of burst transmissions from the active ONUs in a TDMA fashion. The activation of each ONU’s transmitter and window of operation is controlled by the OLT.



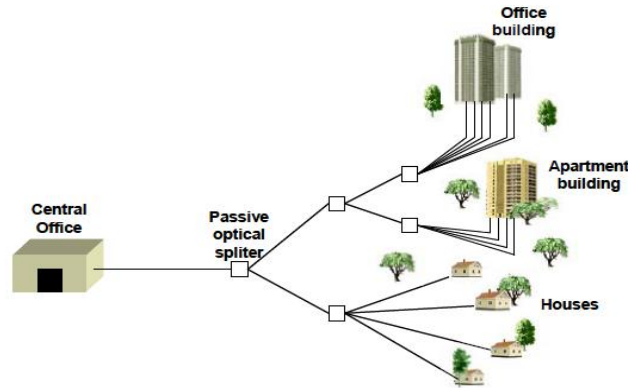

Figure 3.3: Example of tree configuration [Kramer, 2004].

At the physical layer 1310/1490 nm wavelength band were adopted for the upstream/downstream direction, respectively. EPON adopted a fixed line rate, configurable preamble and it can provide downstream and upstream line rates of 1.25Gbit/s, but due to the 8B/10B line encoding, the bit rate for data transmission is 1Gbit/s. EPON reaches distances up to 20Km and it allows a maximum of 32 users. The loss budget that EPON support are class A (5 to 20dB loss) and B (10 to 25 dB loss).

With FEC (Forward error correction), a mathematical signal-processing technique that allows the detection and error correction, it is possible to increase the link budget from 3 to 4 dB. FEC is not mandatory for EPON, but with the use of FEC achieving higher bit rates and longer distance from the OLT to the ONU is possible, as well as higher number of splits per single PON tree. When FEC is used the chosen code is RS(255,239). Table (3.1) resumes EPON main features.

Standard	IEEE803.2ah
Bit rates	Downstream: 1250Mbit/s (1Gbit/s Eth) Upstream: 1250Mbit/s (1Gbit/s Eth)
Optical wavelengths	Downstream: 1490nm Upstream: 1310nm
Supported ODN classes	A and B(15 and 20dB)
Split ratio	1:32/1:16 typical
Fiber distance	10/20Km
Transmission Format	Ethernet
FEC	RS(255,239) optional

Table 3.1: Main features EPON [802.3ah, 2008].

At the TC layer the purpose is to reconcile the point-to-multi-point (P2MP) shared physical link of the PON tree with the higher layer protocols, which have been designed for use in P2P links. The TC layer provides the support for (de)multiplexing frames (from) to the MAC layer based on a unique identifier per ONU indicated inside the frame header. Frames are filtered based on this identifier and classified into separate queues emulating discrete logical P2P links between the OLT and the multiple ONUs of the different customer interfaces. This fact allows reaping the economic advantages of sharing the expensive physical resources, while keeping the appearance of a bunch of dedicated links with ordinary protocols above the TC protocol.

In EPON the TC is carried out very simply by a single addition to the common Ethernet framing: the replacement of the 8-byte Ethernet preamble by the so-called logical link identifier (LLID allows EPON to do the downstream transmission). By means of the LLID, EPON ONUs filter the received packets, forwarding to the upper layers only packets carrying the LLID value assigned to each one of them by the OLT during the registration phase.

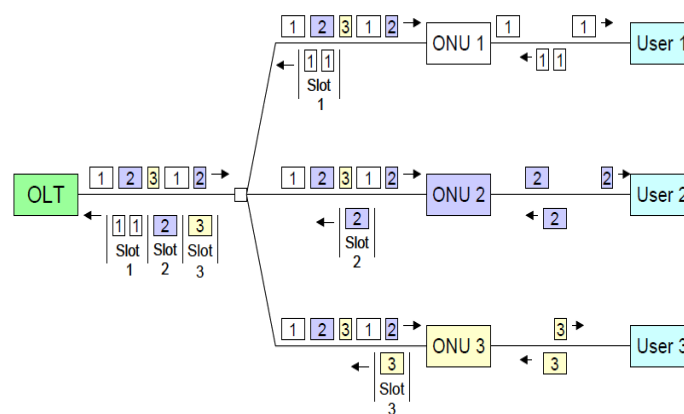

Figure 3.4: EPON Downstream and Upstream transmission [Kramer, 2004].

In the EPON case, the multi-point control protocol (MPCP) is used to arbitrate the upstream access. MPCP uses two types of messages (encapsulated in Ethernet frames) during normal operation for arbitration of packet transmissions: the REPORT message used by an ONU to report the status of its queues to the OLT (up to eight reported in a single message) and the GATE messages issued by the OLT and indicating to the ONUs when and for how long they are allowed to transmit in the upstream channel. Each GATE message can support up to four transmission grants targeting individual service entities

within the same ONU (i.e. data queues). In the upstream, the granted ONU transmits (possibly) multiple Ethernet frames as many integral packets as can fit into the allocated transmission slot, since fragmentation is not allowed from one or more queues preceded by the indispensable physical layer overhead. It may also transmit REPORT messages in order to request additional grants. In EPONs, the traffic streams arriving at the ONUs from the customer premises are kept in queues. In compliance to the 802.1p prioritization scheme, it is possible to inject the traffic in up to eight (8) logically separate, possibly prioritized, queues holding Ethernet frames, with different QoS requirements, to allow for the enforcement of different service mechanisms.

### 3.1.3. Description of G-PON main features

ITU-T started to work on G-PON in 2002, currently there is the G.984.x series of recommendations, which makes G-PON a mature technology. G-PON concern is to provide an improved bandwidth and a more efficient IP transport. Many characteristics of G-PON were improved from the previous technologies.

G-PON can provide a bit rate of 2.4Gbps in downstream direction and even support symmetric bit rate. In upstream direction is possible to have 1.2Gbps or 2.4Gbit/s. The option 2.5Gbit/s in downstream direction and 1.2Gbps in upstream direction seems to be the most applied.

G-PON encapsulation method is used to support any type of service (For example: Ethernet, TDM, ATM). Offering higher bandwidth than previous technologies and efficiency, giving the opportunity to service providers to keep the traditional services (voice based on TDM, leased lines) without having to change the equipments already installed on the client premises.

Apart from the need to support higher bit rates, the overall protocol has to support operation, administration and maintenance (OAM) functionality.

The physical reach is the maximum distance between an ONU/ONT and an OLT. G-PON has two options defined for physical reach that could be 10 Km or 20 Km.

The maximum possible splitting for G-PON is 128, meaning that it can support 128 clients on the same fiber. Splitting ratios like 1:32 and 1:64 are also very applied in a G-PON scenario, like is resumed in table (3.2).

Standard	ITU G.984
Bit rates	Downstream: 2.5Gbit/s Upstream: 1.25/2.5Gbit/s
Optical wavelengths	Downstream: 1490nm Upstream: 1310nm
Supported ODN classes	A,B and C (15/20/25dB)
Split ratio	1:32/1:64/1:128
Fiber distance	20Km
Transmission Format	Ethernet, ATM, TDM

Table 3.2: Main features G-PON [G.984.1, 2008].

From the standpoint of administration access network, the appearance of protection on the G-PON is considered an improvement on the reliability of the network. Protection on the PON section is considered an option, even if the configurations allow more reliability on PON systems its implementations depends on the realization of economical efficient systems. To do the protection on the PON sections we can have two possible switching types, the automatic switching and forced switching. The automatic switching can be triggered by fault detection, such as loss of signal, signal degrade, and so on. The forced switching can be activated by administrative events, such as fiber replacement.

In G-PON Two traffic transmission directions are possible: downstream and upstream. In the downstream direction, ONUs receive the same transmitted frames in which only part of this frames belong to the specific ONU. In the upstream direction, all ONUs share the same transmission frame after pass through the combiner, to send messages to the OLT according to the bandwidth allocation policy scheduled by the OLT in advance.

When there are packets needed to be transmitted from the Service Network to the User Network through the G-PON section, downstream transmission happens in the G-PON section like is shown in Figure(3.5) below:

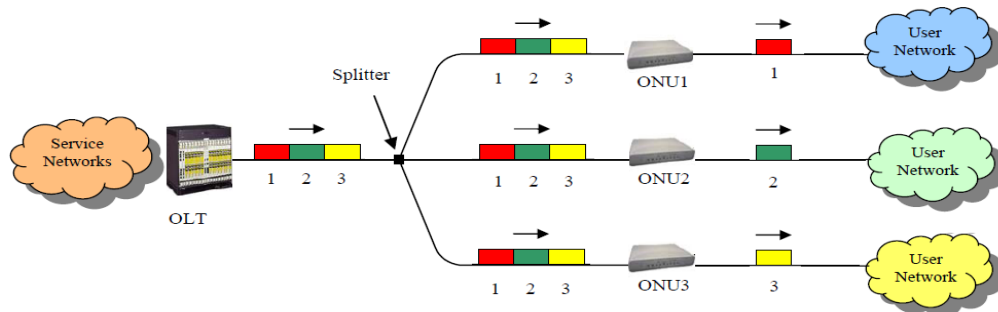

Figure 3.5: Downstream Transmission in G-PON section [Redesign, 2009].

The transmission for the Ethernet traffic in downstream direction starts when the OLT receives the Ethernet traffic from Service Network and checks the destination MAC address, then the OLT checks the lookup table to get related Port-ID according to the MAC address. The OLT encapsulates the traffic to a GEM frame by adding the GEM header that includes the Port-ID and other necessary fields and at the same time, the OMCI message might be included in the GEM header as well. The OLT packs several GEM frames together and appends these GEM frames to the PCBd field that has related a control plane message, upstream bandwidth allocation map and other frame control fields. All this information constructs a GTC frame. To send the GTC frame to the ONUs, the OLT broadcasts this frame. The transmission is complete when the ONU receive the frame.

When there are packets needed to be transmitted from the User Network to the Service Network through G-PON section, upstream transmission happens in the G-PON section shown as below:

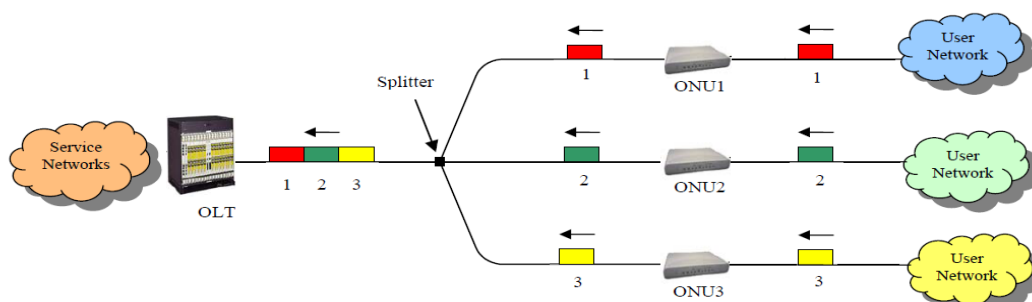

Figure 3.6: Upstream Transmission in G-PON section [Redesign, 2009].

In the upstream direction the ONU gets Ethernet traffic from the User Network, checks the bandwidth allocation map which is contained in PCBd field from a previous downstream. According to the T-CONT and allocation map, the ONU knows how much bandwidth has been allocated to it and related time-slots. The ONU should pack the Ethernet traffic into GEM payload and add the necessary GEM header. If the OMCI message needs to be transmitted from ONU to OLT, it will be encapsulate in the GEM header. The ONU attaches the PLOu field which is mandatory. PLOAMu, PLSu and DBRu fields might be attached as well according to the different requirements including sending the PLOAM response, power level related information and dynamic bandwidth report information. The packet frame is sent by the ONU to the splitter. All these ONU frames will be packed into an upstream frame and transmitted to the OLT side. When the OLT gets this frame, it will split the frame to several units according to the ONU-ID in the PLOu fields. OLT will check the PLOAMu, PLSu and DBRu fields and send a response if necessary. The OLT gets the GEM frames, checks the OMCI messages in the GEM headers, updates the related managed entities if needed and checks the lookup table to get related destination MAC address according to the Alloc-ID. Finally, the OLT gets the GEM payloads which are Ethernet frames from the User Networks. The Ethernet frames will be transmitted to the Service Network according to the destination address;

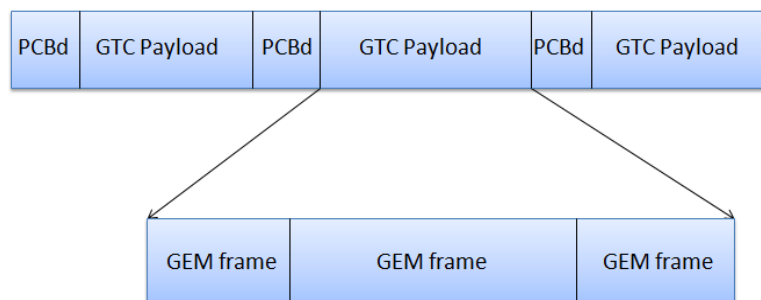

Figure 3.7: G-PON Downstream frame [G.984.3, 2008].

The downstream frame consists of the physical control block downstream (PCBd) and the payload which contains the ATM partition or the GEM partition. An OLT broadcasts downstream to make sure that every ONU will receive the same downstream traffic. After receiving the downstream, every ONU will unpack the PCBd block to get the related information, for example PLOAMd information or upstream bandwidth allocation

information; for the payload block, the ONU will unpack its own payload part according to the Port-ID area.

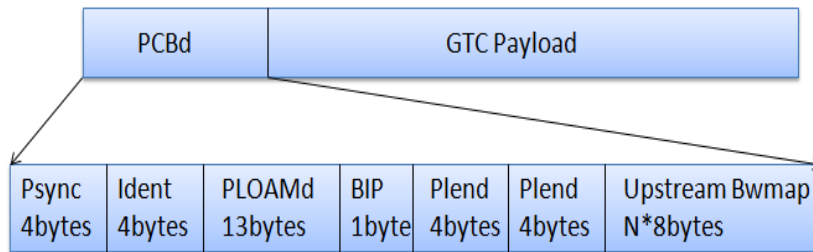

Figure 3.8: G-PON Downstream frame [G.984.3, 2008].

The Physical control block downstream (PCBd) contains several fields, each of which is resumed on the following table:

Field Name	Functionality
PSync	fixed 32-bit pattern that begins every PCBd
Ident	4-byte Ident field is used to indicate larger framing structures, to provide error tolerance, including superframe counter and FEC
PLOAMd	13-byte field that contains the PLOAM message
BIP	8-bit field that contains the bit-interleaved parity
Plend	4-byte field to specify the length of the Bandwidth map and the ATM partition
Plend	4-byte field to be sent twice for error robustness
US BW Map	8-byte field to indicate the upstream bandwidth allocation map

Table 3.3: G-PON Downstream frame [G.984.3, 2008].

US BW Map field is used for allocating the upstream bandwidth for ONUs. It contains several 8 byte entries, each representing a bandwidth allocation Alloc-ID belonging to one T-CONT.

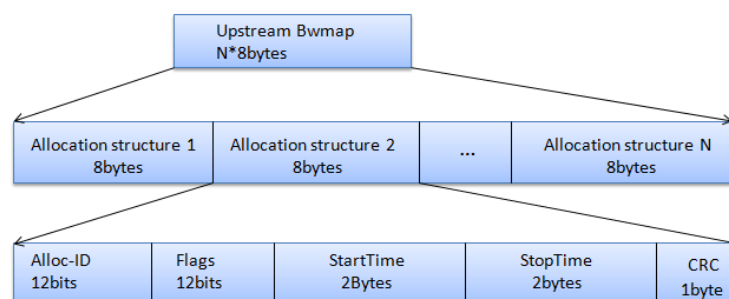

Figure 3.9: G-PON Downstream Frame (BW map) [G.984.3, 2008].

In the static bandwidth allocation mode, an updated US BW Map is transmitted in the next downstream frame after the administrator modifies the allocation policy. If the policy remains unchanged, the same US BW Map is sent in downstream frame. In dynamic bandwidth allocation mode, US BW Map is transmitted in every downstream frame from the OLT to ONUs in order that ONUs can get bandwidth allocation dynamically.

Field Name	Functionality
Alloc-ID	12-bit number that indicates the recipient of the bandwidth allocation, i.e., a particular T-CONT or an upstream OMCC within an ONU
Flags	12-bit field that contains 4 separate indications that control certain functions of the associated upstream transmission
Sstart	2-byte number that indicates the starting time of the allocation
Sstop	2-byte number that indicates the stopping time of the allocation
CRC	To protect the data integration

Table 3.4: G-PON Downstream frame [G.984.3, 2008].

In the payload, one or more GEM headers and GEM sections are transmitted to different ONUs.

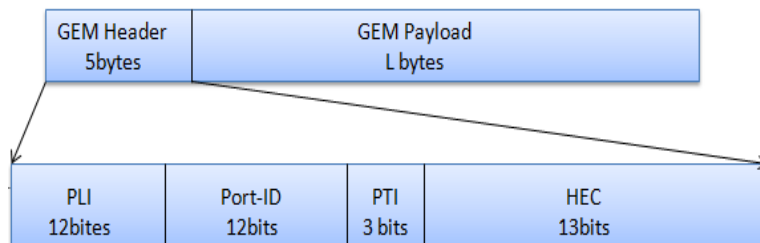

Figure 3.10: G-PON GEM frame [G.984.3, 2008].

The Port-ID in the GEM header is used for GEM traffic identification of the downstream transmission.

Field Name	Functionality
PLI	12-bit field to state the length of the following payload
Port-ID	12-bit field to indicate Port-ID which to identify the payload destination
PTI	3-bit field to indicate the content type of the fragment payload and its appropriate treatment
HEC	13-bit field to provide error detection and correction function.
Fragment payload	Ethernet fragment is carried in the GEM section

Table 3.5: G-PON GEM frame [G.984.3, 2008].



In the Upstream transmission, the frame contains of one or more transmission units, every unit carries PLOu and Payload fields. PLOAMu, PLSu and DBRu are only transmitted when needed. When receiving the upstream message, the OLT will unpack the frame by the ONU-ID in order to know the destination of the message. The following actions will be executed, the OLT:

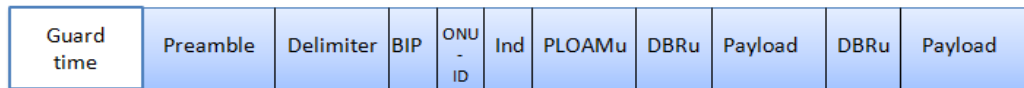

Figure 3.11: G-PON Upstream frame [G.984.3, 2008].

- Analyze the PLOAMu field and carries out management action accordingly;
- Initializes or changes the power mode of the ONU transmitter according to the PLSu field, which contains the power control measurement report;
- Allocates an upstream bandwidth dynamically in accordance to the Dynamic Bandwidth Report in the DBRu field if the DBA mode is running;
- Directs the upstream payload to corresponding receivers.

Field Name	Functionality
PLOu	Physical layer overhead, to tell OLT remain the connectivity with ONU
PLOAMu	3-byte field to transmit the operation and management message from ONU to OLT
PLSu	120-byte field is used for power control measurements by the ONU
DBRu	Dynamic Bandwidth Report upstream, it contains traffic status of a T-CONT
Payload	To transmit the upstream payload

Table 3.6: G-PON Upstream frame [G.984.3, 2008].

### 3.1.4. Description of 10GE-PON main features

It is widely accepted that Passive Optical access Networks (PON) are the most promising cost-effective and high-performance access network solution, they will support bandwidth-intensive applications in the near future. In order to satisfy the market demands for more bandwidth, the IEEE P802.3av Task Force was created in September 2006. The 10G-EPON recommendation was released on September of 2009 [Hajduczenia,2008].

To assure a cost-effective evolution path, the Task Force objectives were set to support both symmetric and asymmetric modes of operation. Upstream and Downstream bit rate are 10Gbit/s in the symmetric version and 10Gbit/s in DS direction and 1,25Gbit/s in US direction. To ensure architectural continuity, backward compatibility, and smooth upgrade paths from existing EPON networks, which is always a very important requirement, the 10G-EPON specification defines a set of new physical medium dependent layers (PMDs), and relies on existing 10G and EPON technologies for the high sublayers. The coexistence with the previous technologies is always a major requirement and factor to choose a lot of the features for a next-generation PON and in the wavelength allocation is no exception. 10G-EPON chosen wavelength is compatible with the wavelength plan of EPON, as expected. For the downstream direction 1575-1580nm are the wavelength, for 1,25Gbit/s (1260-1360nm) and for 10Gbit/s (1260-1280nm) in the upstream direction. At 1Gbit/s the ONUs transmit 8b/10b coded packet bursts in 1260-1360nm at 1.25Gbit/s, while 10Gbit/s ONUs transmit 64b/66b coded packet bursts at 1260-1280nm band at 10.3125Gbit/s.

Due to a coexistence environment or because the needed smooth migration the link budgets of the 10G-EPON standard were defined, to match the currently deployed EPON ODNs. 10G-EPON has an improved maximum channel insertion loss of 29dB (Class B+), to achieve a 29dB channel insertion loss, two PMD classes were established, PRX30 for asymmetric 10G-EPON and PR30 for symmetric 10G-EPON. To meet the maximum channel insertion loss requirement, three requirements are essential: powerful optical transmitters, sensitive optical receivers and Forward Error Correction (FEC) in electrical digital circuits. The FEC function is optional for GE-PON systems, while it is mandatory for 10G-EPON systems to achieve the strict requirement.

The sensitivity of optical receivers decreases with the increase in signal's rate. To compensate for loss of optical sensitivity in 10Gb/s receivers, 10G-EPON specification employs strong forward error correction (FEC) and high-power transmitters to meet the high power budget requirements. The selected FEC code is based on RS(255,223) and belongs to the same Reed-Solomon (RS) family as EPON FEC, though it operates on the bit stream rather than on frames like in the case of EPON devices. FEC operation is also mandatory for all 10G-EPON links operating at 10Gbit/s (in asymmetric configurations,

1Gbit/s links can optionally use IEEE EPON FEC). This stream-based FEC provides constant overhead and simpler integration with the 64b/66b encoding used by the 10G-EPON physical coding sublayer (PCS). It should be mentioned that 64b/66b line coding has low coding overhead at only 3%, so coding efficiency is enhanced when compared with 8b/10b coding used in EPON [Tanaka, 2010]. The 10G-EPON efforts are focused on the physical layer changes. At the multipoint MAC control layer, the protocol is based on the existing multipoint control protocol (MPCP) of EPON, with changes to the discovery process, registration as well as several minor operational aspects including reporting, overhead calculation, etc. [802.3av, 2009].

Standard	IEEE803.2av
Bit rates	Downstream: 10Gbit/s Upstream: 1.25Gbit/s or 10Gbit/s
Optical wavelengths	Downstream: 1575-1580nm Upstream: 1260-1360nm(1.25Gbit/s) 1260-1280nm(10Gbits/s)
Supported ODN classes	A,B and B+(15/20 and 29dB)
Split ratio	1:16/1:32
Fiber distance	10/20Km
Transmission Format	Ethernet
FEC	RS(255,223) mandatory

Table 3.7: 10G-EPON main features [802.3av, 2009].

## 3.2. General comparison of parameters

After understanding EPON, 10G-EPON and G-PON main features, it is possible to make several comparisons between them. The natural comparisons are between G-PON Vs. EPON and EPON Vs. 10GEPON.

### 3.2.1 G-PON vs. EPON

G-PON and EPON development was approximately made at the same time, so a liaison can be found between 802.3ah EFM Task Force and ITU-T group with the goal to align specifications to the extent possible. The main interest of this liaison was the PON

transceiver equipment, once in the overall cost it is considered to have an important impact.

In the end the standards turned out to be quite different for what was expected, due to influences from the interests of different participants with different reviews, concerns and requirements. The few similarities are a common wavelength plan and minimum and maximum power for the transceivers.

Most of the differences are related to the architecture of both technologies. EPON employs a single Layer 2 network that uses IP to carry data, voice, and video. The G-PON network structure consists of multiple Layer 2 networks on the same physical layer.

Clearly G-PON and EPON differ in layer 2, but this is not the only difference between them. There are also differences in terms of efficiency, range, bandwidth, cost per user, management, protection, among others.

Recommendation G.984.1 analyze both symmetrical and asymmetrical gigabit-capable passive optical network, although 2.4Gbit/s down and 1.2Gbit/s up is more important, constituting nearly all of the deployed G-PON systems. In the other hand EPON offers the symmetric rate of 1.24Gbps.

With respect to system efficiency, G-PON features lead to superior performance. Apart from the inefficiency introduced by the 8/10 bit coding adopted in EPONs, which limits the available upstream rate to 1Gbit/s instead of 1.24Gbit/s, in G-PON efficiency when transporting Ethernet traffic is also better in terms of allocated slot utilization due to GEM encapsulation. Although GEM encapsulation introduces a header of 5 bytes on each upstream frame or segment of frame, it allows segmentation and reassembly of Ethernet frames achieving a nearly perfect fit. Hence, while in G-PON the inefficiency stems from the GEM overhead, in EPON inefficiency is introduced by the longer physical layer overhead and the longer reporting message (3 bytes per queue in G-PON vs. 64 bytes for all eight queues in EPON).

For both technologies, the practical limitation depends on the budget provisions for the optical link. With the range specified for the two networks of

approximately 20km, the difference in ability to division of the optical splitters and the number of optical network units (ONU) supported for each OLT, are two factors that became the point of difference for the two technologies. G-PON offers support up to 128 ONUs, while the EPON standard, according to the amplitude of the laser technology can typically serve up to 32 ONUs per OLT or 64 ONU per OLT in cases where is used FEC.

EPON requires a simple management system, while G-PON depends on three management systems for all three Layer 2 protocols. This means a lower cost for EPON network, in addition EPON does not need conversions of multiple protocols which implies another factor of cost reduction in the network.

The process of AES (Advanced Encryption Standard) is part of the standard ITU-T G-PON networks. However, the encryption on G-PON is only used in the downstream direction. In EPON, the encryption mechanism is not defined in standard, but some vendors also use AES in EPON. Service OAM (Operation, Administration and Management) is also present in both technologies, G-PON uses PLOAM (Physical Layer Operations, Administration and Management) + OMCI (Open Manage Client Instrumentation) instrumentation and control open to the client. EPON uses OAM defined for Ethernet.

The IEEE 802.3ah EPON supports only two types of ODN: Type A (5dB to 20dB loss) and type B (10dB to 25dB loss), offering service to 32 users, while G-PON also supports C-type ODN (15dB to 30dB of loss). The C-type ODN enables PON networks extend beyond the 20Km and serve up to 64 ONUs. The use of EPON enables sellers to eliminate complex and expensive elements of ATM and SONET networks by simplifying procedures thus considerably reducing costs in the network. Table 3.11 present a summary of the main features of G-PON and EPON respectively.

Standard	ITU-T G.984	IEEE803.2ah
Bit rates	Downstream: 2.5Gbit/s Upstream: 1.25/2.5Gbit/s	Downstream: 1250Mbit/s (1Gbit/s Eth) Upstream: 1250Mbit/s (1Gbit/s Eth)

Optical wavelengths	Downstream: 1480-1500nm Upstream: 1260-1360nm	Downstream: 1490nm Upstream: 1310nm
Supported ODN classes	A,B and C (15/20/25dB)	A and B(15 and 20dB)
Split ratio	1:32/1:64/1:128	1:32/1:16 typical
Fiber distance	10/20Km	10/20Km
Transmission Format	Ethernet, ATM, TDM (GEM)	Ethernet

Table 3.8: G-PON Vs. EPON main features.

### 3.2.2 10G-EPON vs. EPON

A comparison between 1G-EPON and 10G-EPON technologies comes naturally, in a perspective where 10G-EPON is nothing more than an improvement of 1G-EPON.

The biggest concern that covers 1G-EPON and 10G-EPON is the important smooth migration. Since 1G-EPON is already being deployed over the world, it is necessary to ensure that the investment made on 1G-EPON is not wasted, ensuring a complete backward compatibility with already mass-deployed 1G-EPON. Similarly the symmetric 10G/10G-EPON further provides an upgrade path towards higher data rate in the upstream direction. Smooth migration from 1G to 10G is possible for one ONU at a time and without any changes to the ODN, or the already deployed ONUs. As a result, network providers can maximize life cycles for existing fiber systems by deploying and/or upgrade to more bandwidth demanding services using next generation access network structure of 10G-EPON.

It should be noted that for both symmetric and asymmetric 10G-EPON scenarios, the downstream transmission takes advantage of the wide deployment 10GbE point-to-point devices. The upstream burst timing is again relaxed (following closely in the footsteps of 1G-EPON, where a small decrease in efficiency was traded off for a significant reduction in device). Such a timing relaxation allows for the possible use of existing off-the-shelf components. It is expected that the cost of 10G-EPON equipment will be comparable to that of 1G-EPON, therefore, accelerating the adoption of 10G-EPON in the commercial networks.

Fortunately, the 1G-EPON standard also provides a solid foundation for multi-vendor interoperability, which is another key factor for driving the 10G-EPON market acceptance. Ensuring standard compliance also guarantees interoperability for layers that are in scope for IEEE 802.3.

Besides the obvious improvement in the data rate 10G-EPON has a different wavelength plan, in downstream direction are used 1575-1580nm and in upstream direction are used 1260-1360nm for 1.25Gbit/s and 1260-1280nm for 10Gbit/s. To improve the ODN classes supported, this new standard enables to have a power budget of 29dB (ClassB+). 10G-EPON relies on three main characteristics:

- Low power budget class supports P2MP media channel insertion loss  $\leq 20$  dB e.g., a PON with the split ratio of at least 1:16 and the distance of at least 10 km.
- Medium power budget class supports P2MP media channel insertion loss  $\leq 24$  dB e.g., a PON with the split ratio of at least 1:16 and the distance of at least 20 km or a PON with the split ratio of at least 1:32 and the distance of at least 10 km.
- High power budget class supports P2MP media channel insertion loss of  $\leq 29$  dB e.g., a PON with the split ratio of at least 1:32 and the distance of at least 20 km.

In table (3.12) there is a summary of the main features of EPON and 10G-EPON main features.

Standard	IEEE803.2ah	IEEE803.2av
Bit rates	Downstream: 1250Mbit/s (1Gbit/s Eth) Upstream: 1250Mbit/s (1Gbit/s Eth)	Downstream: 10Gbit/s Upstream: 1.25Gbit/s or 10Gbit/s
Optical wavelengths	Downstream: 1490nm	Downstream: 1575-1580nm

		Upstream: 1310nm	Upstream: 1260-1360nm(1.25Gbit/s) 1260-1280nm(10Gbits/s)
Supported classes	ODN	A and B(15 and 20dB)	A,B and B+(15/20 and 29dB)
Split ratio		1:32/1:16 typical	1:16/1:32
Fiber distance		10/20Km	10/20Km
Transmission Format		Ethernet	Ethernet

Table 3.9: 10G-EPON vs. EPON main features.

Both standards use RS code to do the FEC implementation, the difference come from the fact that in 10G-EPON FEC is mandatory for 10Gbit/s data rate and RS(255,223) code is used. In 1G-EPON FEC use is optional and when used to reduce BER value (Bit Error Rate) the employed code is RS (255,239).

### 3.3. Opening and space for the XG-PON

In order to provide higher bandwidth in a cost-effective way one of the first solutions to consider was BPON. After some initial deployment of BPON, the industry rapidly realized that a BPON ODN could not be incrementally upgraded to any next-generation technologies. The logistics to upgrade an entire PON simultaneously were overwhelming, and the cost of installing a parallel upgrade PON was prohibitive. Consequently, it was a requirement from the early days of G-PON development that next-generation upgrade be incrementally possible on the same ODN.

The primary driver for the evolution of G-PON is the expected consumer bandwidth demand for IP-based standard definition TV (SDTV) and particularly high-definition TV (HDTV) services. An extensive demand for HDTV services is expected in the near future and once this kind of service demands a high capacity in the downstream direction, it is necessary to evolve from G-PON to a higher capable PON.

Although G-PON is considered to offer enough capacity for some years to come, the Next Generation G-PON systems (NG-PON) are proving to be future-proof and consequently a good solution for the migration from the currently deployed G-PONs and fiber infrastructures. The basic requirements of NG-PON are thus to offer higher capacities



than G-PON while maximally re-using the G-PON protocol, components and infrastructure.

With this requirements XG-PON seems to be the natural upgrade solution, it guaranties the compatibility with the already deployed G-PON, makes possible a gradual and smooth migration to the next generation of PON systems, and gives the necessary bandwidth boost that is expected to ensure new quality services and more clients served at the same time.

## Chapter 4. Main features of XG-PON1

### 4.1. Network architecture

XG-PON architecture follows the typical PON architecture, basically it consists of an OLT (Optical Line Termination), multiple ONUs (Optical Network Unit) connected by an ODN (Optical Distribution Network) and passive optical splitters. There is a one-to-many relationship between the OLT and the ONU/ONTs respectively [G.987.1, 2010].

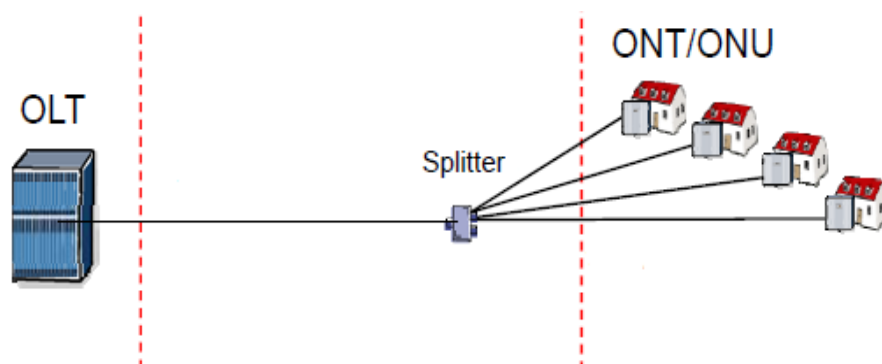

Figure 4.1: XG-PON architecture [Kunigonis, 2008].

G-PON systems can allow several network architectures, depending on the distance from the ONU and different services supported, since ODN is common to all architectures [G.987.1, 2010].

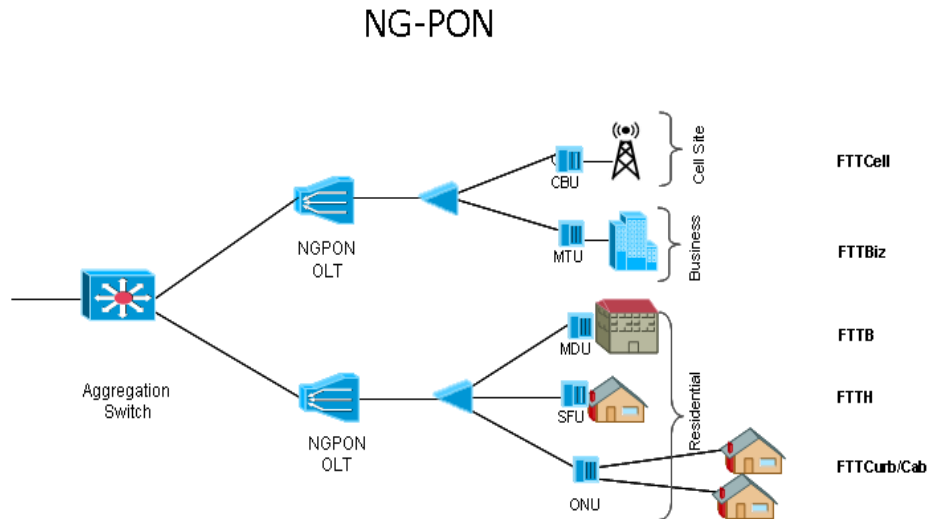

Figure 4.2: XG-PON use cases [FSAN, 2009].

Figure 4.2 presents several architecture possibilities for NG-PON. An architecture where the slope ends at the entrance of a building (Commercial or residential) is a FTTB (Fiber-To-The-Building) architecture. The optical fiber ends before reaching the living space, the path can be continued by other means (such as copper or wireless) to the subscriber.

As shown in Figure (4.3), the optical signal arrives at the closet of the telecommunications building, which makes the conversion from optical to electrical. From this point, the signal is interfaced to the building metal network with copper cable.

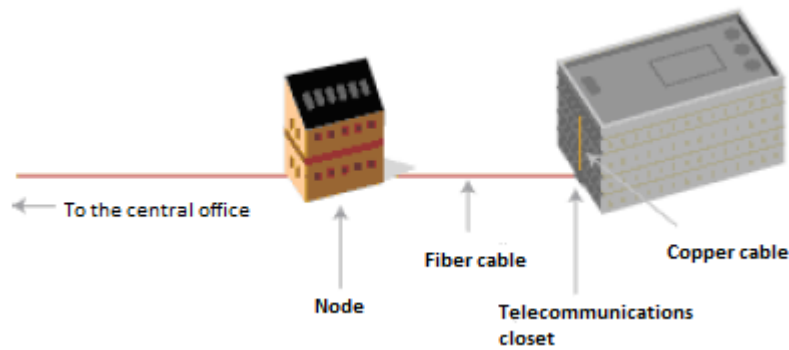

Figure 4.3: FTTB architecture [Kunigonis, 2008].

In a FTTB scenario there are two situations possible, which are FTTB for MDU when residential users are being served and FTTB for MTU for business users. In these two scenarios different services are provided depending on the type of client (if it is a residential or business user).

When the ONU is located on each residential house, we have FTTH (Fiber-To-The-Home) architecture. This topology offer higher bandwidth but is the most expensive solution.

There are also possible others architectures like FTTC/FTTCab (Fiber-To-The-Curb/Fiber-To-The-Cabinet), FTTO (Fiber-To-The-Office) and FTTCcell which is a Wireless scenario where the ONU is called CBU (cellular backhaul unit) and it will have to offer connectivity to wireless base stations. XG-PON should extend the G984.6 reach extenders capability, inherited from the G.984 recommendations series, to produce an increased optical budget to achieve longer distances and/or additional passive split.

## 4.2. Migration scenarios

One of the most important concerns of XG-PON deployment is that the migration from G-PON to XG-PON has to be as smooth as possible. Once G-PON is already being deployed over the world, it is necessary to ensure that the investment made on G-PON is not in vain. XG-PON recommendation already contains two possible scenarios for migration, one that is based on a brown field and another based on a green field. In the first case the migration of the PON subscribers can be done when they want

more bit rate, or when there is a small portion of subscribers still in the G-PON system and in this case a ‘forced migration’ is necessary. In this scenario the coexistence between G-PON and XG-PON is going to last a long time. Still in a brown field scenario it is possible that the network operator wants to replace the G-PON network for a XG-PON. In this case, the idea is to upgrade one set of users at a time, maintaining operational both G-PON and XG-PON. The duration of this process is supposed to last less than for the first scenario.

On a green field the idea is the deployment of a XG-PON network where no G-PON has been deployed. Obviously this migration scenario requires a bigger investment than the brown field and it might take long time. One of the advantages of this option is that it doesn’t require compatibility with the existing G-PON system and at the same time it can provide the same or better bandwidth per user and represent a better economical solution with the maturity of the XG-PON technology.

## 4.3. Service Requirements

### 4.3.1. Services

As the market moves from a standard-definition broadcast model to one dominated by on-demand high-definition television (HDTV), there is an increasing need for more bandwidth on the PON, and it is here where XG-PON plays an important role. During the standardization of XG-PON the compatibility with legacy services and the ability of providing new services was one of the most important topics that defined XG-PON characteristics. This is one of the best advantages that XG-PON provides, it makes this standard more complex but it results to be a great appeal.

Typically a XG-PON system supports delivery of IP-based data and telephony services, broadcast IPTV, and on demand content delivery. To accommodate the specific communication needs of businesses, XG-PON support different numbers of POTS ports, DS1/E1 ports, and Ethernet. To provide the legacy services it can use either simulation and/or emulation. XG-PON1 is more sophisticated has an implicit general requirement that is support to IPV6.

## 4.3.2. Qos and traffic management

Many people sees IPTV technology not just as a change, but as an entirely new service type, a video experience offering two-way entertainment, gaming, commerce, and communications. These two-way, high-speed services require QoS mechanisms. Also, legacy business services such as TDM require robust, low-latency, low-jitter performance with the same transport protection that service providers offer with their current architectures.

The ITU G.987 XG-PON standard not only supports redundancy but provides an intrinsic PON-layer QoS mechanism that goes beyond Layer 2 Ethernet and Layer 3 IP class-of-service (CoS) methods to ensure delivery of high-quality voice, video, and TDM data over a TDMA-based shared media.

XG-PON has also to support a large variety of services, not only residential, business, and mobile backhaul traffic within the same PON. It also has to support a mix of consumer and business users within a multiple subscriber ONU. XG-PON must support mix of rates based (including committed information rate (CIR)/peak information rate (PIR) provisioning, policing, shaping, etc.) and priority based traffic management within the same PON and same ONU.

## 4.4. Physical layer requirements

### 4.4.1. Optical wavelength

The operating wavelength range is 1575-1580nm for the downstream direction and 1260-1280nm for upstream direction. In addition, the wavelength plan has four optional enhancement bands. The most interesting optional band is from 1480-1560nm, because it allows the use of video distribution services (1550-1560nm) and/or the use of GPON. XG-PON also includes guard bands. In this approach the upstream and the downstream are separated from the enhancement band avoiding interference between these bands which can cause signal degradation.

## 4.4.2. Bit rates

XG-PON1 offers a bit rate of 10Gbit/s in downstream direction and 2.5Gbit/s in upstream direction. It is expected that in a near future XG-PON will be able to support 10Gbit/s in upstream direction, having the symmetric option. This standard is called XG-PON2 and is not expected yet.

## 4.4.3. Optical power budget

Loss budget is divided in “Normal” and “Extended” according to if either pos/pre-amplifiers are used or not. When optical pos/pre-amplifiers aren’t in use, the loss budget is called “Normal”, and is divided in two types: normal 1 (29dB) and Normal2 (31dB) for a BER penalty of 1E-12. When pos/pre-amplifiers are employed, the loss budget is called “Extended” [G.987.2, 2010].

## 4.4.4. Split ratio

What is interesting in split ratio is that more is better, obviously in an operator’s perspective. Because greater splitting implies an increased power budget to support the physical reach. Therefore XG-PON minimum split ratio is 1:128 in order to keep compatibility with G-PON, which is always an interesting requirement for XG-PON. If compatibility with G-PON is not an obligation, splitting ratios of 1:128 to 1:256 are a great improvement for XG-PON and it can really get the attention of service providers.

## 4.4.5. Fiber distance

The physical reach is like in GPON the maximum distance between an ONU/ONT and an OLT. XG-PON has an improved physical reach; it has to support a maximum fiber distance of at least 20Km.

## 4.5. System level requirements

## 4.5.1. Dynamic bandwidth Assignment (DBA)

Dynamic bandwidth allocation (DBA) is a methodology that allows quick adoption of user's bandwidth allocation based on current traffic requirements. DBA is controlled by OLT, which allocates bandwidth volume to ONUs. This technique works only in upstream direction, in downstream direction traffic is broadcasted.

In order to utilize the unused bandwidth to offer higher speed connections and better upstream QoS to residential and business users, the bandwidth allocation mechanism must be dynamic.

To indicate the dynamic activity is possible to use the Status reporting DBA (SR-DBA) method, employing the explicit buffer occupancy reports that are solicited by the OLT and submitted by the ONUs in response, is also possible to use the traffic monitoring DBA (TM-DBA) method, employing OLT's observation of the actual traffic amount in comparison with the allocated upstream transmission opportunities. Any of these methods shall be supported as well the possibility of a combination of both.

The two methods can be resuming by having a status report or none having status report, which was determinant to the previous nomenclature of TM-DBA, because it's previous name was non-status-reporting DBA (NSN-DBA) in G.984.3. This name was considered to be ambiguous and corrected in G.987.1. In TM-DBA all OLTs provide traffic monitoring DBA and the OLT monitors the incoming traffic from ONUs. In SR-DBA the OLT can obtain the congestion status from ONUs and complete the information.

## 4.6. Operational requirements

### 4.6.1. Resilience and protection ODN

Protection on the PON section is considered an option on XG-PON, even if the protection configurations allow more reliability on PON systems, their implementation depends on the realization of economical systems. In XG-PON1, service resilience is an important characteristic, once it covers services like IPTV. These high value services are



very important to protect against failures in the shared portions of the PON, which will impact multiple costumers and services.

XG-PON1 follows the protection architectures that are explained on G.984.1, both duplex and dual parenting duplex system configurations. The expectation is that the recovery time should be a few tens of milliseconds, for critical and important services, or minutes for residential applications.

To do the protection on the PON sections we can have two possible switching types, the automatic switching and forced switching. The automatic switching can be triggered by fault detection, such as loss of signal, signal degrade among others. The second one is activated by administrative events, such as fiber rerouting, fiber replacement, etc.

## 4.7. Framing

### 4.7.1 Downstream frame

XG-PON framing format is similar to the already deployed for G-PON, consists of a header and a payload section. Frames duration is 125 $\mu$ s and they are 155520 bytes long, corresponding to a downstream of 9.95328Gbit/s.

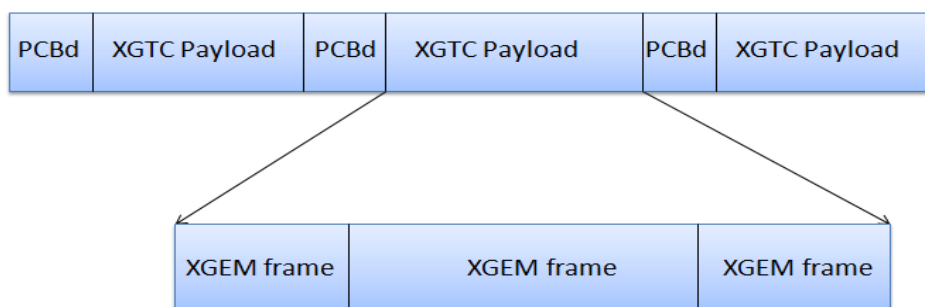

Figure 4.4: Downstream XGTC frame [G.987.3, 2010].

The PCBd is filled with overhead to control and inform the ONU and is sent in broadcast from the OLT to the ONUs. A payload section contains the actual data which has to be transferred. The PCBd header contains several fields which are shown in figure (4.5).

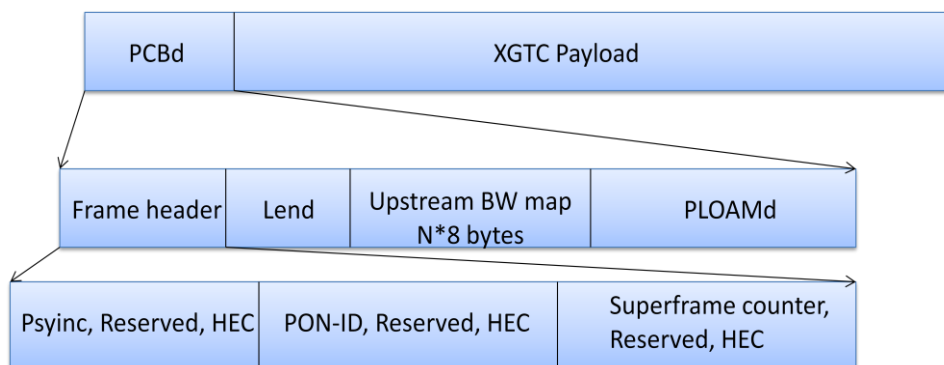

Figure 4.5: XGTC physical control block downstream (PCBd) [G.987.3, 2010].

Frame header is 24bytes long and is subdivided is 3 fields, PSync, PON-ID and Super frame counter, all of this three fields are 8 bytes long. Physical synchronization (PSync) it is used by the ONU to synchronize on the incoming bitstream. The superframe counter section is used to indicate larger framing structures.

The Lend field is called the Length downstream field and it has 3 fields, Blen, Plen and HEC. BWMap Length (Blen) field, gives an indication of the bandwidth map length, this field is 11 bits long. Next field is Plen it has the length of the PLOAM messages and is composed by 8bits. The last field in the Len partition, it has 13bits and provides error detection and correction functions for the header.

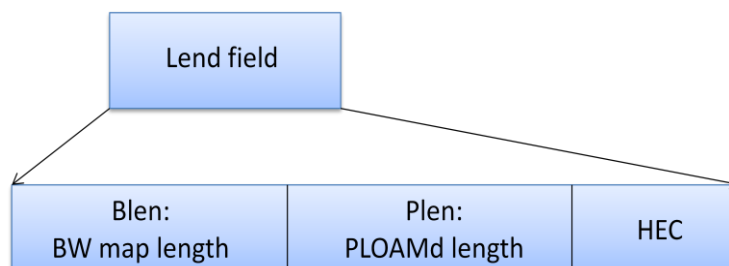

Figure 4.6: Lend field [G.987.3, 2010].

The “Bandwidth map” (BWmap) contains the fields which describe the access slots for an ONU. The fields are shown in figure (4.7).

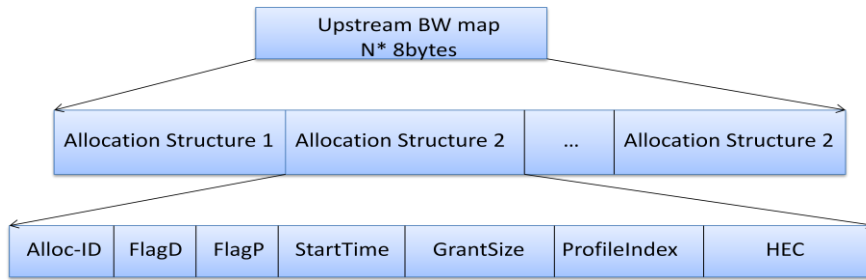

Figure 4.7: XGTC bandwidth map allocation structure [G.987.3, 2010].

BWmap fields are summarized in the following table:

Field Name	Functionality
Alloc-ID	14-bits field, specifies for what access path the T-CONT is assigned.
FlagD	1-bit field, indicates the ONU to send dynamic bandwidth report upstream (DBRU)
FlagP	1-bit field, indicates if the ONU should send its PLOAMu information during this allocation.
StartTime	2-bytes field, indicates the starting time of the allocation in the upstream frame.
GrantSize	2-bytes field, indicates the length of the transmitted data from this allocation.
ProfileIndex	3-bit field, contains 3 separate indications that control certain functions of the associated upstream transmission.
HEC	13-bit field, provides error detection and correction functions for the header.

Table 4.1: XGTC bandwidth map allocation structure [G.987.3, 2010].

Finally the PLOAMd field is 32bytes long and contains one or more PLOAM messages. The XGTC payload section follows the PLOAMd field, it contains several XGEM messages. Payload section has the actual user data.

## 4.7.2 Upstream frame

For the upstream direction, the frame format is totally different although the frame duration is the same (125µs) and it contains a header and payload section like a downstream frame. The structure of the XG-PON upstream frame is mostly the same that G-PON. The first field is the Physical layer overhead Upstream (PLOu).



Figure 4.8: XGTC layer upstream overhead XGTC bandwidth map allocation structure [G.987.3, 2010].

The first two fields of the PLOu are filled with a so called Preamble and Delimiter bytes. The ONU-ID field contains the unique ONU-ID of the sending ONU. Ind Field is used to send a real time ONU status report to the OLT. The PLOAMu hold the same function, carrying OAM messages from ONU to OLT. The DBRu is a 4 byte field that carries the dynamic bandwidth allocation report of the T-CONT for the payload that is being sent in the following payload fields of the current frame from ONU.

## 4.8. General comparison of parameters

### 4.8.1 G-PON vs. XG-PON

XG PON systems fundamentally need to be fully backward-compatible with the existing G-PON and analog video overlay infrastructures that have already been deployed in the field. Thus it becomes possible to provide a smooth migration from 1Gbit/s to 10Gbit/s system, which is always a requirement for XG-PON. By having the required compatibility between them it is possible to have the same fiber plant base, and allows joint operation of legacy and new PON systems. As a result, it can be maximized the life cycle of the existing fiber systems and deploy or upgrade faster services over next-generation access networks whenever needed.

The need for more and more capacity, both for the end user access and the transport networks is a reality. So the different bit rates of G-PON and XG-PON are really desired in the evolution path of PON technologies. G-PON has two bit rate option, 2.4Gbit/s DS direction and 1.2Gbit/s UP direction and 2.4Gbit/s DS, 2.4Gbit/s UP direction. Recommendation G.984.1 analyze both symmetrical and asymmetrical gigabit-capable passive optical network, although 2.4Gbit/s down and 1.2Gbit/s up option is the most deployed and planned to be deployed of the G-PON systems. The asymmetric option of XG-PON is already being researched and it has 10Gbit/s in the downstream direction and 2.5Gbit/s in upstream direction, however the symmetric option is not expected yet.

The chosen wavelength plan is also different for both standards, G-PON has 1480-1500nm DS, 1260-1360nm UP direction and XG-PON has 1575-1580nm/1260nm-1280nm DS/UP direction. The chosen wavelength came from the need of coexistence of both standards.

XG-PON is designed to co-exist with G-PON where typical split ratios are 32, 64 and 128 and XG-PON can go up to 256 and 512 in a green field scenario. XG-PON splitting ratio of 256 or 512, in a coexistence environment, may be limited by the reduced splitting ration tolerance of the G-PON.

XG-PON1 must support a fiber distance of at least 20Km in G-PON fiber distance goes from 10 to 20 Km.

XG-PON1 is obviously an improvement of G-PON systems, once it has more data rate, greatest split ratio and more fiber distance. Based on the XG-PON/G-PON comparison is possible to conclude that most of the XG-PON characteristics came from the coexistence requirement of both technologies.

Standard	ITU-T G.984	ITU-T G.987
Bit rates	Downstream: 2.5Gbit/s Upstream: 1.25/2.5Gbit/s	Downstream: 10Gbit/s Upstream: 2.5Gbit/s
Optical wavelengths	Downstream: 1480-1500nm Upstream: 1260-1360nm	Downstream: 15975-1580nm Upstream: 1260-1280nm
Supported ODN classes	A,B and C (15/20/25dB)	A,B and C, C++(15/20/25dB)
Split ratio	1:32/1:64/1:128	1:32/1:64/1:128 1:256/1:512 if compatibility with G-PON is not a requirement
Fiber distance	10/20Km	At least 20Km
Transmission Format	Ethernet, ATM, TDM (GEM)	Ethernet, ATM, TDM (XGEM)

Table 4.2: G-PON vs. XG-PON main features.

## 4.8.2 XG-PON vs.10G-EPON

Due to the known need to satisfy the requirements of users and new services, both XG-PON and 10G-EPON came up in order to fulfill these necessities. XG-PON and 10G-EPON are both improved versions of their antecessors, as they are the 10Gbit/s

versions. In spite of this, they are very dissimilar, due to the differences that came from the previous standards. So it is unlikely to have common specifications for both NG-PON and NG-EPON.

Downstream bit rate of XG-PON and 10G-EPON is 10Gbit/s, although their upstream bit rate is 2.5Gbit/s in the XG-PON version and 1.25Gbit/s in 10G-EPON, due to the necessity to both keep the compatibility with the previous technologies.

Even if 10G-EPON tried to keep up the link budget of XG-PON, they maintain to be different and being XG-PON the technology that allows the higher value. 10G-EPON can go up to 29dB (Class B+) and XG-PON limit is 31dB, which gives the opportunity to go farther from the typical 20Km reach. This is the limit for 10G-EPON and the minimum distance for XG-PON. The same wavelength plan in both standards and the same DS bit rate are the most similar features of both standards. XG-PON grew to be a more exigent standard, offering more allowable power budget, higher splitting ratio and fiber distance. 10G-EPON is a simpler standard offering a good range of services and two bit rate options (symmetric and asymmetric) and it become a more economic standard.

Standard	ITU-T G.987	IEEE803.2av
Bit rates	Downstream: 10Gbit/s Upstream: 2.5Gbit/s	Downstream: 10Gbit/s Upstream: 1.25Gbit/s or 10Gbit/s
Optical wavelengths	Downstream: 15975-1580nm Upstream: 1260-1280nm	Downstream: 1575-1580nm Upstream: 1260-1360nm(1.25Gbit/s) 1260-1280nm(10Gbits/s)
Supported ODN classes	A,B and C, C+(15/20/25dB/31dB)	A,B and B+(15/20 and 29dB)
Split ratio	1:32/1:64/1:128 1:256/1:512 if compatibility with G-PON is not a requirement	1:16/1:32
Fiber distance	At least 20Km	10/20Km
Transmission Format	Ethernet, ATM, TDM (XGEM)	Ethernet

Table 4.3: XG-PON vs. 10G-EPON main features.



# Chapter 5. 10G-EPON Simulations

## 5.1. Introduction

The aim of this chapter is to analyze the limitations associated with the signals transmitted in a 10G-EPON network and which techniques can help to improve the PON performance. 10G-EPON main features are described previously on chapter3. The simulation environment is VPI Transmission Maker software.

The main features analyzed are loss due to fiber coupling, splitting ratio, fiber distance, and coexistence between 10G-EPON /EPON. The laser temperature effect and how these characteristic can affect the transmitted signal is another studied aspect.

## 5.2. Setup description

The setup results from the original model of a 10G-EPON network that already exists in the simulation software, although with several modifications that are necessary to match the 10G-EPON recommendation characteristics. Some main features like the wavelength plan and bit rate were adjusted to the values of the final version of the standard. To allow more than four ONUs, adjustments in the ODN (Optical distributions network) were also required in order to be able to test the splitting ratio impact from 16 ONUs to 32 ONUs. In the OLT and in the ONU pass band filters were also added, to ensure that only the correct wavelength is received.



The setup uses single fiber transmission, presenting a more efficient solution because only half of the amount of fiber is necessary, when compared with the two fiber solution. Transmitting in downstream and upstream using different wavelengths is a simple way to transmit avoiding interference between signals, as they are carried in separate frequencies. This option requires sources of different wavelength as well as optical filters to divide upstream and downstream link channels.

Definitely, bidirectional single-fiber transmission is the most interesting scheme to be developed in the access network.

Maximum range of the network is 20 km and it has a maximum of 32 physical ONU's that can be supported. Communication from the CO towards the subscribers is entitled downstream traffic (package signals are sent over the network at a wavelength of 1575-1780nm), the opposite direction is called upstream traffic using Time Division Multiple Access (TDMA) transmitting signals towards CO at a wavelength of 1310 nm±50nm.

10G-EPON deployed setups share the structure depicted in figure 5.1, with some variations for each situation tested.

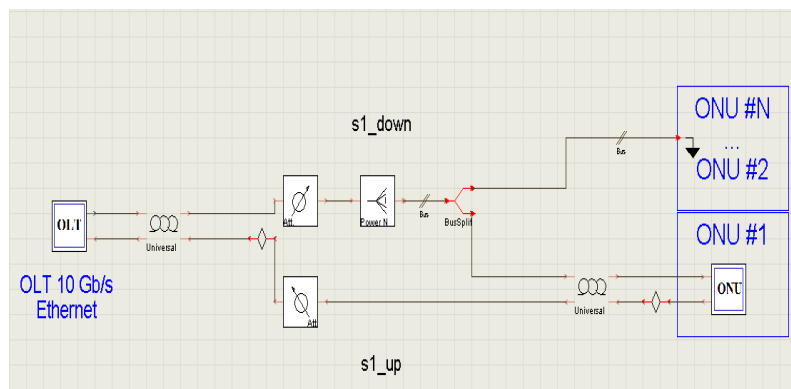

Figure 5.1: 10G-EPON main setup, with 1:N splitting ratio.

The transmitter and the splitter/combiner are connected by a SSMF (Standard Single Mode Fiber), the ONUs and the splitter/combiner are also linked by a SSMF, once this kind of fiber is the most popular already installed.

Data transmitter for downlink consist of 10Gbit/s PRBS generator, NRZ driver, CW externally modulated laser at 1577 nm wavelength, and Mach-Zehnder external modulator.

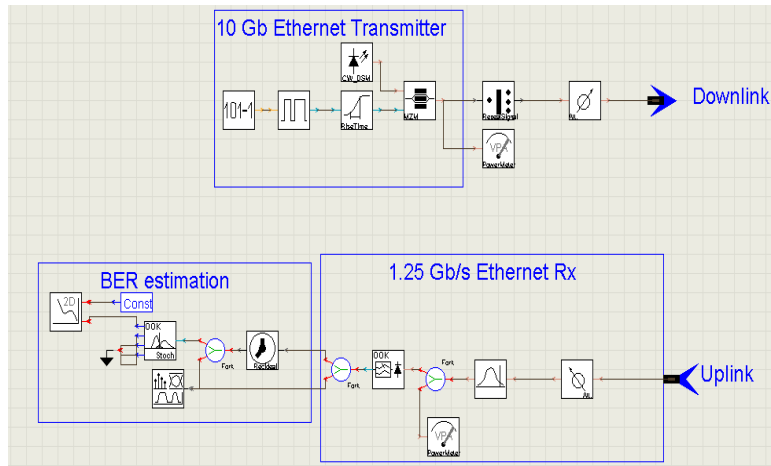

Figure 5.2: 10G-EPON OLT.

The signal is detected and received by the user in the ONU side by either a PIN photodetector or an APD depending on the studied scenario.

The upstream signal consists of a 1.25Gbit/s PRBS generator, NRZ driver, CW externally modulated laser at 1310nm wavelength, and amplitude modulator. At the OLT side the upstream signal passes a band pass filter and is finally detected. OLT filter ensure that the upstream frequency is isolated and is finally detected by the photodetector.

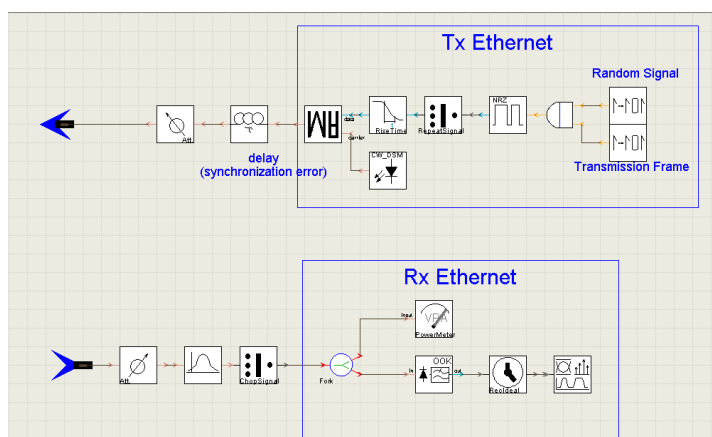

Figure 5.3: 10G-EPON ONU.

Essentially four situations were analyzed in this architecture. The 10Km of fiber and 16 ONUs option (which is the situation with lower requirements), 20Km of fiber and 16 ONUs, 10Km of fiber and 32 ONUs, these two situations belonging to the medium power budget option [802.3av, 2009]. Finally, last situation tested involves 20Km of fiber and 32 ONUs, being the most challenging one, however it is also the architecture that allows to serve more clients in the same access network and cover higher fiber distance.

To meet the maximum power budget requirement, three technologies are essential: powerful optical transmitters, sensitive optical receivers and Forward Error Correction (FEC) in electrical digital circuits. FEC is mandatory for 10G-EPON.

Although FEC it is not implemented in the setup, its impact in the signal is essential to achieve the expected power budget. Taking FEC into account in the simulated architectures would have increased drastically system complexity, in order to maintain the setups as simple as possible, the concept adopted by FEC code RS(255, 223) was applied in all the tests, considering that this code enables an improvement in BER from  $10^{-3}$  to less than  $1 \times 10^{-12}$  [802.3av, 2009].

The specifications of components in this simulation model are tabulated in table 5.1.

Component	Parameter type	Value
PRBS Generator	Downstream bit rate (Gbit/s)	10
	Upstream bit rate (Gbit/s)	1.25
Light source	Downstream wavelength (nm)	1575-1580
	Upstream wavelength (nm)	1260-1360
Filter	Insertion Loss (dB)	0.5
Splitter/combiner 1:16/1:32	Insertion Loss (dB)	15/17
SMF	Attenuation constant (dB/Km)	0.2

Table 5.1: Components specifications.

## 5.3. Results

### 5.3.1. Loss analysis

Typical splitting ratios for 10G-EPON are 1:16 and 1:32, the first two simulation scenarios use the lower value (1:16), which already limit the total insertion loss since 1:16 splitter/combiner has a total insertion loss of 15 dB, that came from the 12dB loss of the Splitter/combiner and additional 3dB insertion loss.

Transmission distance between OLT and ONU is 10 km in the first simulated situation. According to the 802.3av standard, this is the Low power budget class with a maximum insertion loss of  $\leq 20$ dB. To receive the signal with the minimum necessary quality (in this case BER= $10^{-3}$ ), considering maximum insertion loss, the output power of the 1577nm laser was adjusted to approximately 2dBm. Moreover, the power budget of the architecture has follows, 10 km single mode fiber (SMF) (2 dB), one attenuator (0.5 dB) in the OLT side and another attenuator (0.5 dB) in the ONU for the downstream direction, thus the total loss budget of the system is around 18 dB which meets the requirements. Minimum insertion loss due to the coupling to the fiber and to the receiver is 0.5dB in each side, established by the attenuators. In order to determine the insertion loss limit value, either for the coupling penalty, splice, safety margin, or all mixed together it is possible to increment the global parameter (Loss) established in the attenuators (in the OLT and in ONU).

The minimum sensitivity value of the optical receiver is -24,19dBm using the maximum insertion loss, which puts the power budget in 26,19dB. The receiver sensitivity is the minimum amount of power received that is necessary to maintain the signal with a good performance, which in this case is at a BER of  $10^{-3}$ . The link power budget determines the amount of total loss due to attenuation and other factors that can be introduced between the transmitter and the receiver. The loss variation (Figure 5.4) shows

an increase in bit error rate until approximately the limit value  $10^{-3}$  and puts the limit value for additional insertion loss in 8.19dB. Results are only considered starting from 23.5dB of total loss because until this value the system was error free.

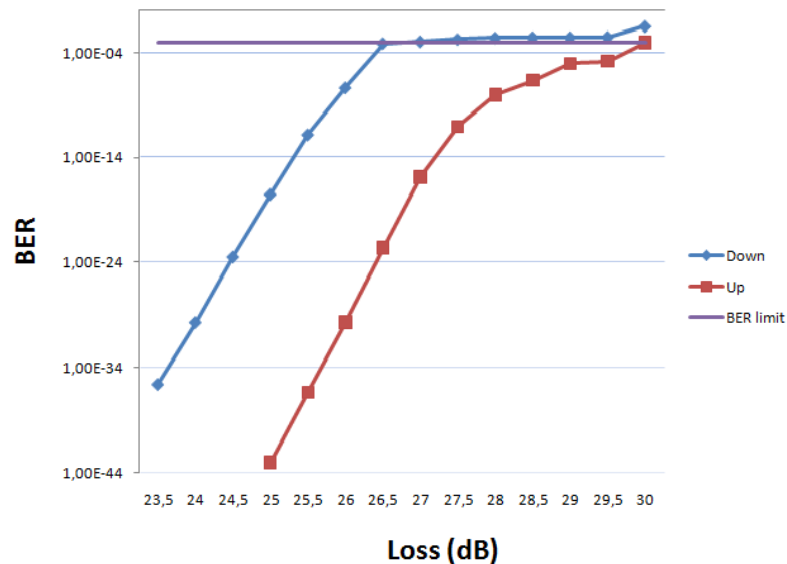

Figure 5.4: BER Vs. Loss (Low power budget class).

The same point was used to optimize the laser power (2,55dBm) for the upstream direction. In the ONU side loss is due to an attenuator of 0.5dB. In the reception another attenuator of 0.5dB is employed, so the total insertion loss in the upstream direction is also 18dB. Sensibility in the upstream side is less than -28dBm at a bit error rate of  $10^{-3}$ , granting 30,55dB of power budget, which gives a good margin from the standard establishments.

Increasing fiber distance to 20Km, add (2dB) to the loss in the ODN. Output laser power in the downstream and upstream remain 2dBm and 2,55dBm, because total loss is inside the range of the allowable insertion loss.

With 32 users it is necessary to update the output power of the 1577nm and the 1310 lasers to 2,55dBm and 3,5dBm respectively. Loss in the ODN is in this case much higher because of the splitter/combiner loss that increases up to 17dB, which puts the total insertion loss in 21dB for downstream and upstream direction. Receiver's sensitivity is in this case -24,45dBm and -26,56dBm respectively. Figure 5.5 presents the Medium power budget class (insertion loss  $\leq 24$ dB) for 1:16, 20Km and 1:32, 10Km.

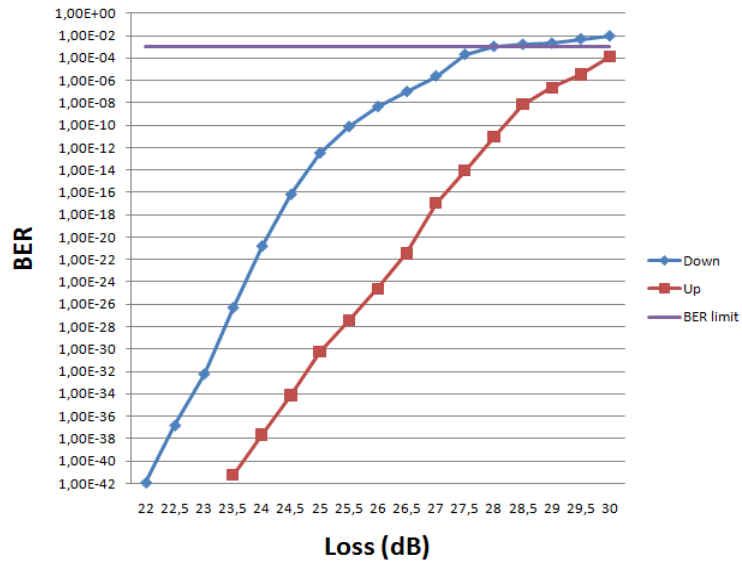

Figure 5.5: BER Vs. Loss (Medium power budget class).

When fiber distance goes up to 20Km, total loss is 23dB in downstream and upstream direction. This is the most challenging power budget class. With 3,01dBm and 4,14dBm of output laser power is possible to come upon the 29dB of maximum insertion loss. Receivers sensibility are -29,12dBm and less than -32dBm. In this case to accomplish the maximum insertion loss is necessary to use APD receivers once this kind of photodetector has a higher range of sensitivity.

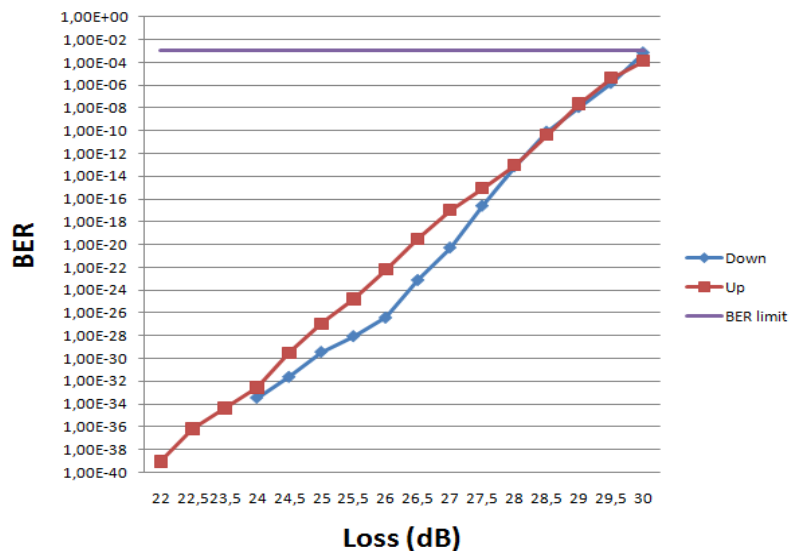

Figure 5.6: BER Vs. Loss (High power budget class).

Figure 5.6 shows BER variation versus optical loss for the higher budget class. The power budget is approximately 32dB for downstream and 35dB for upstream direction. In both cases is a sufficient margin compared with the PRX30 power budget requirement of 30.5dB (maximum channel insertion loss 29.0 dB + maximum dispersion penalty 1.5 dB). The resume of all the variations is in the following table.

	Tx Power	Rx Sensibility	Power budget	Minimum insertion loss	Extra insertion loss
1:16 10Km	2.01dBm	-24.19dBm	26.19dB	18dB	8.19dB
	2.55dBm	-28dBm	30.55dB	18dB	12.55dB
1:16 20Km	2.01dBm	-24dBm	26dB	20dB	6dB
	2.55dBm	-28dBm	30.55dB	20dB	10.55dB
1:32 10Km	2.55dBm	-24.45dBm	27dB	21dB	6dB
	3.5dBm	-26.56dBm	30.6dB	21dB	9.06dB
1:32 20Km	3.01dBm	-29.12dBm	32dB	23dB	9dB
	4.14dBm	-31dBm	35dB	23dB	12dB

Table 5.2: Sensitivity resume.

### 5.3.2. Temperature analysis

Most optical transmitters are required to stably maintain system performance, such as average optical power and extinction ratio over a wide temperature range. In this section the allowable temperature range is tested in order to determine the best range to operate.

Due to the increase in the laser temperature the transmission performance can be degraded. To evaluate the temperature effect in the VPI software, the CW laser was changed to a similar version, enabling to change the temperature and test among which values of laser temperature is possible to have the best performance. The splitting ratio and fiber distance have no effect over the temperature, so it is not necessary to analyze the four scenarios presented previously. With the Low power budget class is possible to test how the laser temperature variation can affect the transmitted signal.

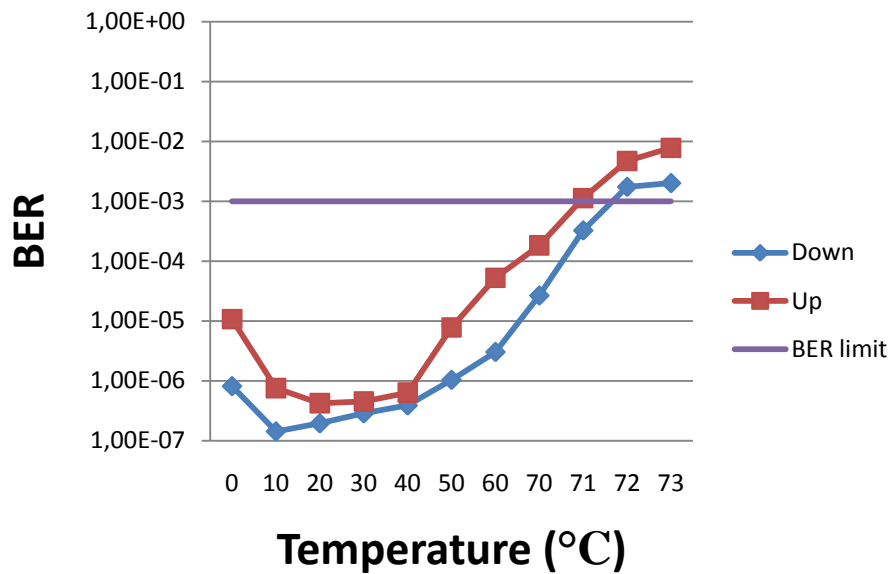

Figure 5.7: BER Vs. Temperature.

BER variation is not regular due to the temperature effect on the signal. The allowable temperature range is from 0°C to 71°C at bit error rate of approximately 1e-3, and the best performance is from approximately 20° to 40°C, which puts the lower BER values in the middle of the curve. With the 2.01dBm of laser power at 1577nm and 2.55dBm at 1310nm the sensibility in the reception of the signal is -26,28dB and in this case with the limit temperature (71°C) the sensibility is degraded 2dB, once the maximum sensibility is -26,28dBm.

### 5.3.3. 10G/1G-EPON coexistence

To achieve the coexistence between 10G-EPON and EPON is necessary the use of a WDM multiplexer and a demultiplexer to combine and separate the individual wavelength of each one. The use of WDM devices in this setup ensures a more simpler and efficient wavelength control, because the signal can only pass through the WDM device if the laser is operating at the correct wavelength. This extra component increases minimum insertion loss in 2dB, which results in a total insertion loss of 20dB. Center frequency is



190THz for 10G-EPON and 200THz for EPON and they both have a bandwidth of 200GHz.

$$\text{Center frequency1} = \frac{3e8}{1577e-9} = 190\text{THz} \quad (6.1)$$

$$\text{Center frequency2} = \frac{3e8}{1490e-9} = 200\text{THz} \quad (6.2)$$

This system separates properly both wavelengths, once the signals are received in both cases with a maximum bit error rate of  $10^{-3}$ .

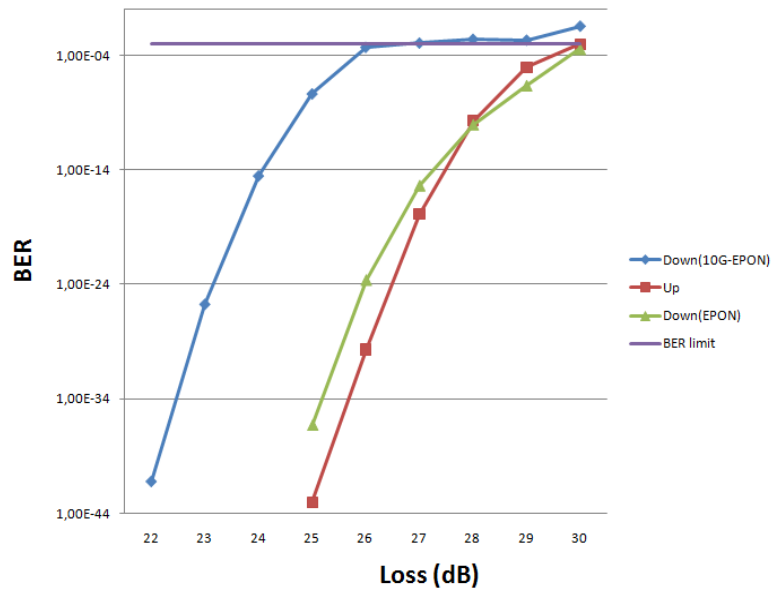

Figure 5.8: BER Vs. Loss (Coexistence scenario).

For 10G-EPON laser power is 2.01dBm like in the scenario with no coexistence and sensibility is approximately -26dBm, allowing a power budget of 28dB. In EPON case the laser power is also 2dBm and the sensibility is -28.37dBm, ensuring a maximum insertion loss of 29.37dB. EPON system has a better performance, allowing higher insertion loss than 10G-EPON.

## 5.4. Conclusion

With the previous analyzes is possible to establish some boundaries in the sensibility required for each situation. The values at the table are from the Low power budget class, only to have some references, because the variations are almost the same but at different values. The resume of these variations are at the following table.

Receiver sensitivity (dBm)	Tx/source variables		Connector/cable variables			
	Temperature	Coupling to the fiber	Fiber loss	Coupling to the receiver	Total coupling +Safety margin +Repair +Splice	Coexistence with EPON
-10						
-15						
-20	±2dB	±4dBDown ±6dBUp	±2dB	±4dBDown ±6dBUp	±8dBDown ±12dBUp	±2dB
-25						
-30						

Table 5.3: Summary of the sensitivity ranges in several points in the network.

Temperature variation has a 2dB effect at the sensibility. Coupling to the fiber and coupling to the receiver are in this case ±4dB for downstream direction and ±6dB for upstream direction, if these are the only penalty factor established in the network. This is the factor that is more variable from each simulation, because it depends on the minimum launch power and the minimum insertion loss, which is different for each case. The transmitted signal has also different performances at different bit rates, with a higher bit rate the signal is more affected by the dispersion factor. In the 1:16 splitting ratio and 10Km of fiber the minimum insertion loss is 18dB and the allowable power budget is 26,19dB in the downstream direction and 30,55dB in the upstream direction, which makes possible a slightly different power budget.

The extra power budget is more likely divided not only in the coupling loss, but also in the safety margin and others penalty effects like repair and splice.

Coexistence with EPON, implies extra components do make sure that only the correct wavelength are transmitted and there is no interference between them. These extra components have an extra insertion loss of 2dB. This not requires a higher launch power, because is still in the range allowable for the insertion loss.

## Chapter 6. Conclusions and future work

### 6.1 Conclusions

This work presents a summary of the most deployed PON systems, their next generations, as well as a comparison between them.

A general description of how a PON system works and assigning to the PON systems the best way to respond and satisfy the today requirements was the main objective of chapter one. Chapter two addressed the evolution of PON standardization.

Starting with the positioning of PON in past and presented the status, chapter three describes the main features of EPON, G-PON and 10G-EPON. EPON main features are 1.25Gbit/s and 1.25Gbit/s in DS/UP directions, with an allowable splitting ratio of 1:16 and 1:32. The wavelength plan is 1480-1500nm and 1260-1360nm in DS/UP directions. It can transmit to a maximum distance of 10 to 20Km, depending on the link loss budget and on the splitting ratio. FEC is optional for EPON, although when it is used it gives an extra supported splitting ratio of 1:64. G-PON bit rate is 2.5Gbit/s in DS direction and 1.25Gbit/s or 2.5Gbit/s in UP direction, which ensures asymmetric and symmetric bit rate option. The wavelength plan is the same as EPON and it supports 1:32, 1:64 or 1:128 splitting ratios. It can reach a maximum fiber distance of 20Km, again depending on the link loss budget and splitting ratio. 10G-EPON as the 10Gbit/s version of EPON has a bit rate of 10Gbit/s in DS direction and 1.25Gbit/s or 10Gbit/s in UP direction. Wavelength plan is different in order to allow compatibility between both. In downstream direction is

used 1575-1580nm and in upstream is used 1260-1280nm in the symmetric version and 1260-1310nm in the asymmetric option. Splitting ratio is again 1:16 or 1:32 and the maximum fiber distance goes from 10 to 20Km. An improvement from the previous recommendation is the maximum loss budget, which in this standard is 29dB (Class B+). In this case FEC is mandatory in order to achieve good performance.

EPON and G-PON comparison was also made in this chapter. As EPON and G-PON were deployed at approximately the time line it was an interest to get some compatibility between them, but it had to be dropped because of the different requirements that both SDOs have and in the end they came out very different. The most notable similarities are the same wavelength plan and a common minimum and maximum required power for the transceivers.

Differences that pass through efficiency, range, bandwidth, management, protection among others make impossible to have coexistence between both standards. The EPON efficiency is drastically affected by the relatively large overheads, which makes G-PON the standard with best bandwidth efficiency. The range differences came with the maximum splitting ratio supported and G-PON is again the best provisioned in this field, once with the same range (20Km) can serve up to 128 users. Bandwidth differences are clear due to the highest data rate of G-PON (2.5Gbit/s DS, 1.25Gbit/s US). EPON greatest advantage is the simplicity of the network when compared with the G-PON standard that requires a much more complex management system for all three Layer 2 protocols that need. These recommendations differ in protection as EPON not have defined in the recommendation the process of AES (Advanced Encryption Standard), although it is used in downstream and upstream directions and G-PON has this process in the recommendation, but only in downstream direction. This is precisely the opposite of what happens with EPON and 10G-EPON, as they are totally related. The differences mostly came from the improvements suffered by the recommendation, like bit rate and power budget.

In chapter four are presented the main features of XG-PON (G.987.x) standard, which is the most recent one. XG-PON is also an improved standard. In this case is the improved version of G-PON and their differences and similarities also came from the requirements of higher bandwidth, number of served users or power budget between

others. XG-PON and 10G-EPON are also compared in this chapter, although that most of the dissimilarities already came from their previous versions and the impossibility to have some coexistence between them is stronger in these case.

In chapter five is presented the performance and analysis of a 10G-EPON scenario. Increasing the users number, fiber distance and loss, requires an increase in the transmitters power to meet the minimum bit error rate (BER) of  $10e-3$ . In the most challenging scenario is possible to conclude that is necessary to use a combination of high laser power, sensitive photodetector and FEC, in order to meet the  $10e-3$  minimum BER. With loss and temperature variation are established some boundaries in the photodetector sensitivity. 10G-EPON standard is very limited when compared with XG-PON, because of its low splitting ratio, maximum reach and loss budget, even if this fact makes this recommendation more simple and because of that more economic.

## 6.2 Future work

Traditional optical solutions based on point-to-point architectures are expensive for access configurations. To achieve the aim of cheap access networks the passive point-to-multipoint topology has been developed. Passive Optical Network (PON) has more advances because the number of active equipment is relatively low, that can increase cost-efficiency and decrease complicity in maintenance compared with traditional solutions. Current PON systems have bandwidth limitations due to fundamentals of time division, as they are based on TDM (Time Division Multiplexing). 10G-EPON, XG-PON1 and the symmetric version XG-PON2 are TDM systems, operating at a higher data rate and comprehending the NG-EPON1 and NG-PON1 systems, they do not change anything dramatically in the PON architecture and they suffer from the bandwidth limitation. XG-PON2 is expected to be the ultimate version of TDMA-PON. The trend from ITU-T to this standard requirements were to be based upon the 802.3av PHY and MAC layers [yoshimoto, 2009], however the XG-PON2 system was announced out of focus for the

next few years, due to the lack of interest in the symmetric version of XG-PON1 and the high cost of this technology [ONTC, 2009]. The main way to overcome these limitations is the use of Wavelength Division Multiplexing (WDM-PON), which belong to the NG-PON2 or NG-EPON2, depending on the base technology being the ITU-T approach or the IEEE. This new technology requires rather a revolution than an evolution in the NG-EPON1 and NG-PON1 several recommendations. NG-PON2 and NG-EPON2 depends on a complete make-over in order to go from the first-generation PON architectures to the next generation, changes like the replacement of the Splitters/Combiners for wavelength routers (AWG- Arrayed Waveguide Grating) are necessary to ensure better a performance, once wavelength routing is more efficient than simple power splitting [Redesign, 2009].

Currently there is no standard for WDM-PON, so different realizations are being proposed focus on the network architecture. By having in each OLT-ONU pair a dedicated and permanent wavelength assignment, it requires two transmitters/receivers. Such architecture is not satisfactory for future implementations because each ONU has to be fixed to a specific wavelength thus increasing the maintenance and replacement costs.

The successful solution to upgrade PON is based mainly on colorless ONUs rather than any other enhancement, which is possible by using tunable lasers or an alternative WDM-PON design based on a reflective architecture. The tunable lasers option offers the best performance, although at high cost. Adding the fact that it may require additional network control and management to set and maintain wavelengths. Besides the highly cost it is possible that is the best solution in a long term perspective. Reflective architectures take a different approach since the upstream transmitter within a ONU only requires a reflective optical modulator seeded by the shared source signal, the cost of the network is substantially reduced.

At this time a few commercial WDM-PON systems are ready for deployment, but due to the high cost when compared to the actual TDM-PON they still need to be researched in order get competitive or in the other hand the interest from the residential users and business customers have to grow and make this an appealing PON [ONTC, 2009]. PON future passes through WDM-PON, which is a promising future broadband access network.





## References

- [**Angelopoulos, 2004**]- John D. Angelopoulos, Helen-C. Leligou, Theodore Argyriou, and Stelios Zontos, “Efficient Transport of Packets with QoS in an FSAN-Aligned G-PON”, National Technical University of Athens, 2004.
- [**Alveirinho, 2009**]- Luís Alveirinho, “Redes de Telecomunicações de Nova Geração Um salto qualitativo rumo ao futuro”, Portugal Telecom, 2009.
- [**CIP, 2006**]- CIP “WDM-PON Technologies”, White paper, 2006.
- [**FSAN, 2009**]- Anna Cui, Fabrice Bourgart, Frank Effenberger, Junichi Kani, and Hiroaki Mukai, “FSAN NG-PON White Paper”, FSAN, 2009.
- [**Gutierrez, 2008**]- Lluís Gutierrez, Marilet de Andrade and Sebastià Sallent, “New trends on Optical Access Networks: DBAs for 10G EPON and Long-Reach PON”, Invited paper, 2008.
- [**G.983.1, 2005**]- ITU-T, “High Speed optical access systems based on Passive Optical Network (PON) techniques”, ITU-T Recommendation, 2005.
- [**G.984.1, 2008**]- ITU-T, “SERIES G: TRANSMISSION SYSTEMS AND MEDIA, DIGITAL SYSTEMS AND NETWORKS”, TELECOMMUNICATION STANDARDIZATION SECTOR OF ITU, 2008.
- [**G.984.3, 2008**]- ITU-T, “SERIES G: TRANSMISSION SYSTEMS AND MEDIA, DIGITAL SYSTEMS AND NETWORKS”, TELECOMMUNICATION STANDARDIZATION SECTOR OF ITU, 2008.
- [**G.987.1, 2010**]- ITU-T, “10 Gigabit-capable Passive Optical Network (XG-PON): General Requirements”, TELECOMMUNICATION STANDARDIZATION SECTOR OF ITU, 2010.

[**G.987.2, 2010**]-ITU-T, “10-Gigabit-capable passive optical networks (XG-PON): Physical media dependent (PMD) layer specification”, TELECOMMUNICATION STANDARDIZATION SECTOR OF ITU, 2010.

[**G.987.3, 2010**]-ITU-T, “XG-PON Transmission Convergence layer specification”, 2010.

[**Hajduczenia, 2008**]- Marek Hajduczenia, Pedro R. M. Inácio, Henrique J. A. da Silva, Mário M. Freire, Paulo P. Monteiro, “10G EPON Standardization in IEEE 802.3av Project” OFC/NFOEC, 2008.

[**Hajduczenia,2009**]- Marek Hajduczenia, Henrique J. A. da Silva, “Next-Generation PON – A Quick Look at Current Status”, ONTC Newsletter PRISM Vol. 1. No. 1, 2009.

[**HELSEN, 2010**]- Hartwig TAUBER, Carlos BARROQUEIRO, “FTTH Council Europe”, Press Conference, 2010.

[**IDATE, 2009**]- [www.idate.org/2009/pages/download.php?id=&fic...pdf](http://www.idate.org/2009/pages/download.php?id=&fic...pdf), July 2009.

[**JIANG, 2009**] - Guozhou JIANG, Deming LIUG.P. , “Analysis and implementation of FEC in 10G-EPON”, Higher Education Press and Springer Verlag, 2009.

[**Kani, 2009**]- Junichi Kani† and Ken-Ichi Suzuki, “Standardization Trends of Next-generation 10 Gigabit-class Passive Optical Network Systems”, Global Standardization Activities, 2009.

[**Kramer, 2004**]-Glen Kramer, “On Configuring Logical Links in EPON”, Teknovus Inc, 2004.

[**Kunigonis, 2008**]- Michael Kunigonis “FTTH Explained: Delivering efficient customer bandwidth and enhanced services”, Product Line Manager Access Corning Cable Systems, 2008.

[**Ma, 2003**]- Maode Ma, Yongqing Zhu, Tee Hiang Cheng, “A Bandwidth Guaranteed Polling MAC Protocol for Ethernet Passive Optical Networks”, School of Electrical & Electronic Engineering Nanyang Technological University, 2003.

[**ONTC, 2009**]- ONCT, “ONCT PRISM Newsletter” Vol.1 N.1, 2009.

[**ORPHANOUDAKIS, 2007**]- T. ORPHANOUDAKIS, H.-C. LELIGOU, J. D. ANGELOPOULOS, “Next Generation Ethernet Access Networks: G-PON vs. EPON”, 2007.

[**Redesign, 2009**]- Redesign, “Extending lifetime of HFC Networks”, Research for Development of Future Interactive Generations of Hybrid Fiber Coax Networks, 2009.

[**Tanaka, 2010**]-Keiji Tanaka, Akira Agata, and Yukio Horiuchi, “IEEE 802.3av 10G-EPON Standardization and Its Research and Development Status”, Invited Paper, 2010.

**[yoshimoto, 2009]**- Naoto yoshimoto, “Access Network service systems Labs”, NTT Corporation, 2009.

**[802.3ah, 2008]**- IEEE, “Part 3: Carrier sense multiple access with Collision Detection (CSMA/CD) Access Method and Physical Layer Specifications”, IEEE computer society, 2008.

**[802.3av, 2009]**- IEEE, “Physical layer specifications and Management parameters for 10Gb/s Passive Optical Networks”, IEEE computer society, 2009.