

2017

Huckr

Stephanie Watson

Philadelphia University/Thomas Jefferson University, watson1676@gmail.com

Let us know how access to this document benefits you

Follow this and additional works at: <http://jdc.jefferson.edu/idcapstones>Part of the [Industrial and Product Design Commons](#)

Recommended Citation

Watson, Stephanie, "Huckr" (2017). *Program of Industrial Design Capstones*. Paper 1.
<http://jdc.jefferson.edu/idcapstones/1>

This Article is brought to you for free and open access by the Jefferson Digital Commons. The Jefferson Digital Commons is a service of Thomas Jefferson University's [Center for Teaching and Learning \(CTL\)](#). The Commons is a showcase for Jefferson books and journals, peer-reviewed scholarly publications, unique historical collections from the University archives, and teaching tools. The Jefferson Digital Commons allows researchers and interested readers anywhere in the world to learn about and keep up to date with Jefferson scholarship. This article has been accepted for inclusion in Program of Industrial Design Capstones by an authorized administrator of the Jefferson Digital Commons. For more information, please contact: JeffersonDigitalCommons@jefferson.edu.



HUCKR
THE FIRST OF ITS KIND
STEPHANIE WATSON

1.0

PROJECT OVERVIEW

DESIGN BRIEF

to design a portable and adjustable training aid for ultimate frisbee players
to develop consistent catching skills at team practices

ULTIMATE IS A EMERGING MARKET

Ultimate frisbee, known as ultimate, is a growing sport with over 7.5 million players worldwide. Leagues from youth up to professional players exist in over 90+ countries. The sport has received global recognition through the various world championships that occur and soon in 2024, it will join the Olympics.

As an involved member of ultimate community, I heard many players talk about the importance of learning the fundamentals of the game: throwing & catching.

But many players need years to develop these skills. I wanted to find a way to reduce this practice time to develop into a better player faster.



2.0

RESEARCH



7.5 MILLION
PLAYERS WORLDWIDE

The sport of Ultimate Frisbee was invented in the early 20th century at Yale. The students enjoyed the local bakery pies made by William Russell Frisbie. Post stuffing themselves, students would pass the empty tins shouting, “Frisbie!!” to give a heads up. Fast forward about 50 years, the first commercial disc was created and manufactured eventually leading to today’s discs*. In 1968, the first official known game of ultimate as people know today was played in Maplewood, New Jersey. Soon after, the rules were “codified” by Joel Silver.

Since its creation, it has grown to be played in over 90 countries with local to international leagues and competitions in youth to masters.**

*An Abbreviated History of Ultimate, Compiled by Michael E. Iacovella

** Ultimate Frisbee’s Surprising Arrival as Likely Olympic Sport

HOW CAN PLAYERS PRACTICE CATCHING MORE?

After interviewing players and coaches, they emphasized the importance of throwing and catching.

Here I found an opportunity.

What if there was a way to improve catching and throwing skills; something that can take up to 45 minutes away from practice time depending on the players skill level.

Coaches and captains want practices to be efficient and focused in order to complete the amount that they hope to practice when together. If only, they could run practices like a machine.

50%

**ARE CONCERNED ABOUT THEIR CATCHING SKILLS & BELIEVE THEY
NEED TO PRACTICE IN A SPECIFIC WAY***

* Over 134 players and coaches surveyed

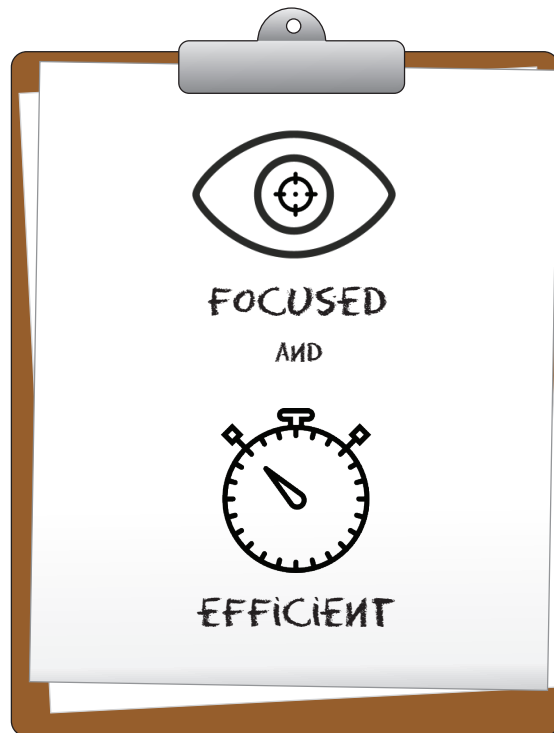
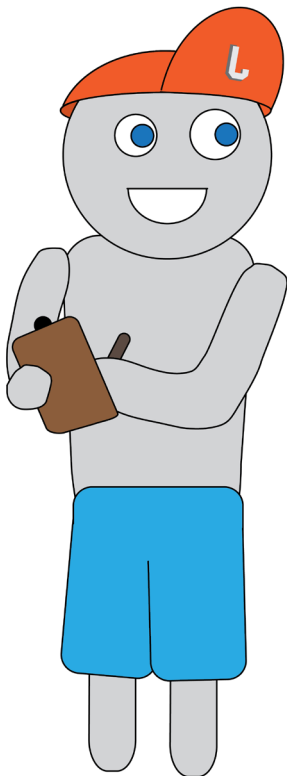

REPEITION & CONSISTENCY

Practice makes better. Better the player, better the team. Allowing players to practice their catching skills repeatedly in less time at practice will give them the opportunity to be confident on the field and practice otherteam skills at group practices.

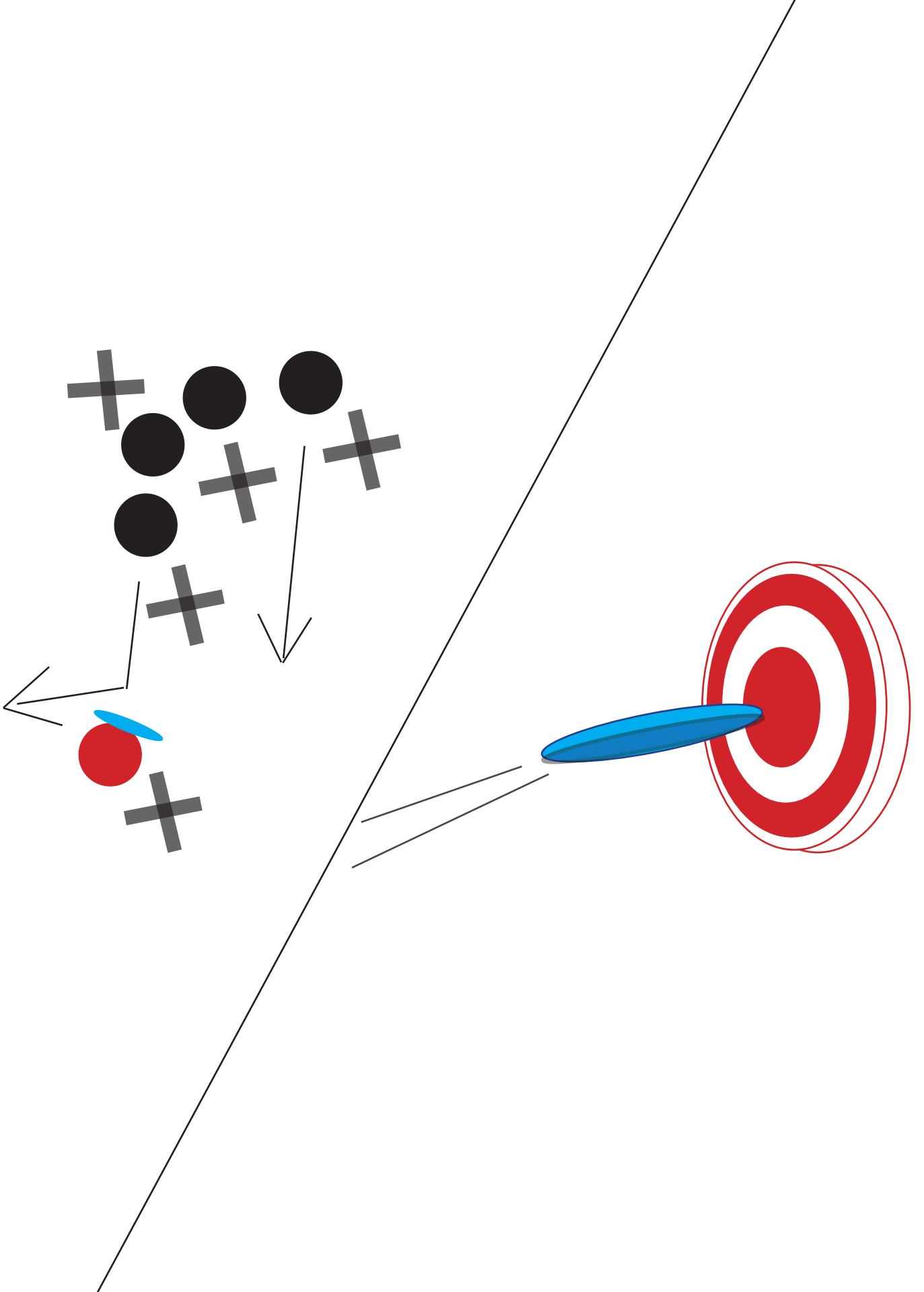

SPEAKING OF MACHINES.....

The immediate opportunity seemed to be a machine that could throw the frisbee repeatedly allowing players to practice catching the disc in a specific way. This would allow the coach to focus on building specific skills and save time searching for inaccurately thrown discs.

Youtube and the ever vast world wide web internet revealed that people had tried to create their own do-it-yourself frisbee launchers from plywood, drills and bike wheels along with two by four catapults and even a spinning mechanism that uses a suction cup to hold the disc in place.

But these projects were dangerous machines built for one environment and had limited features.

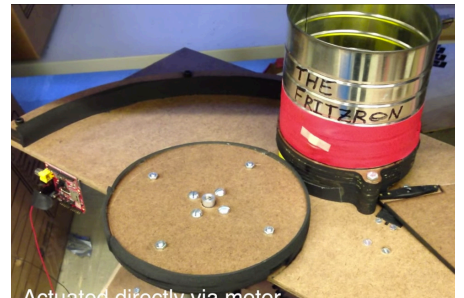
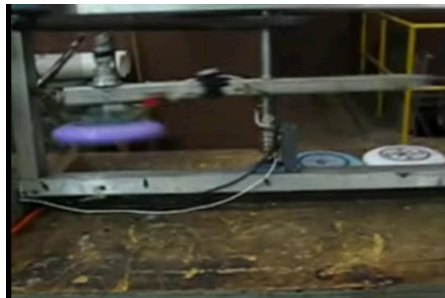

When you search "frisbee launcher" on Youtube, there are about 12,200 results.

THE RISE OF ULTIMATE

With an increase in players and coaches each year, data from USA Ultimate, an organization that sanctions official competitions from youth to national competitions, shows there is room for growth.

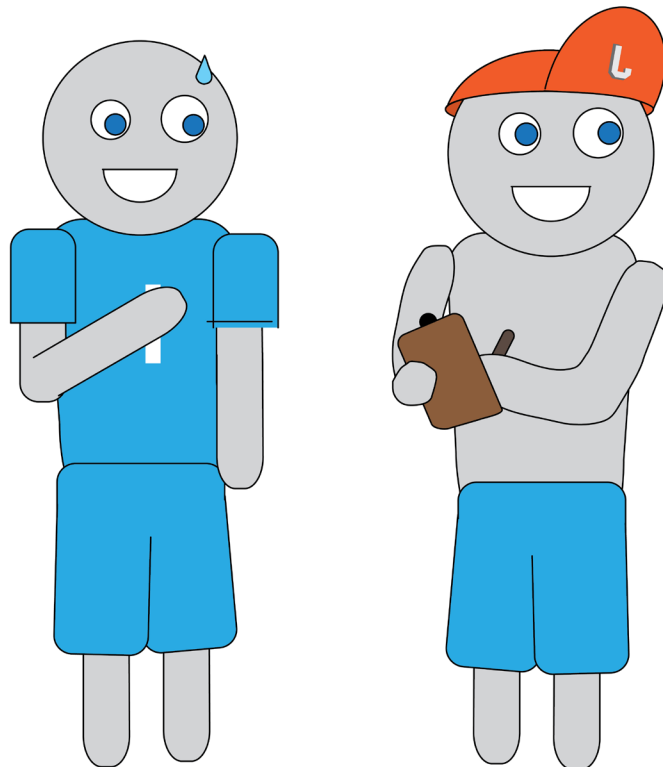

USAU ULTIMATE MEMBERSHIP TRENDS (SELECTED)*

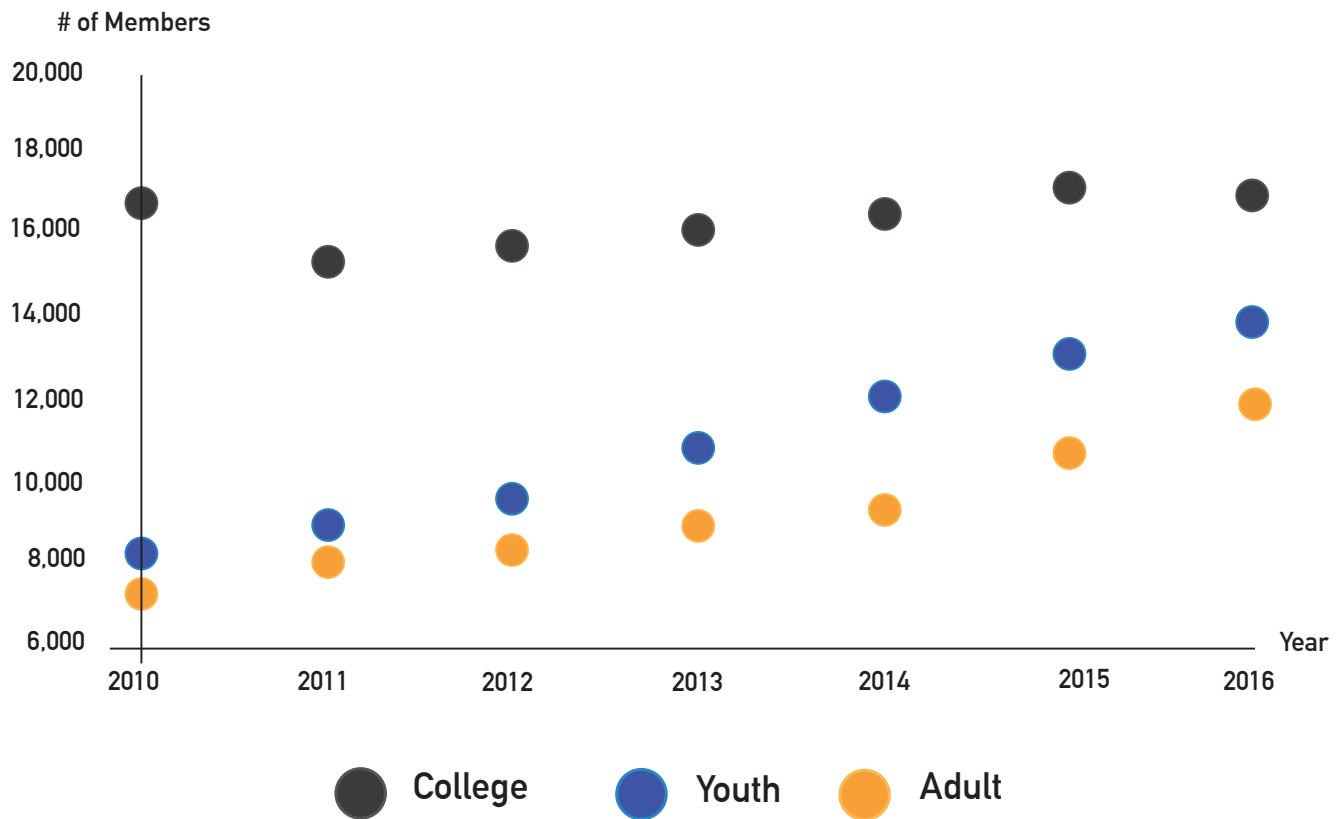

* <http://www.usultimate.org/membershiptrends/>, 27 Jan 2017

THE NEEDS OF THE PLAYER AND COACH

Players and coaches easily spoke to the troubles surrounding these machines. Many of them immediately saw the need for adjustability in order for this to be a useful practice machine. Others pointed out the safety and the need for portability because teams do not have storage at their practice sites.

They also mentioned that the equipment would need to be durable to survive traveling from field to home several times a week and withstand most elements.

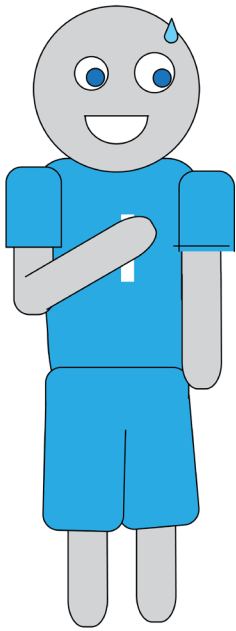

**PORTABLE
DURABLE
ADJUSTABLE**

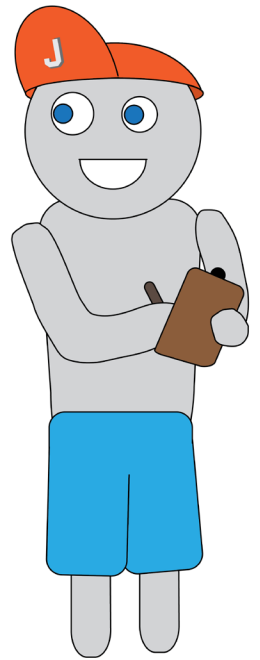

>88% DRIVE OR CARPOOL TO PRACTICE*

*Surveyed from 125 members of the ultimate community

From the design criteria, I learned about the biggest problem with these devices; its lack of portablity.

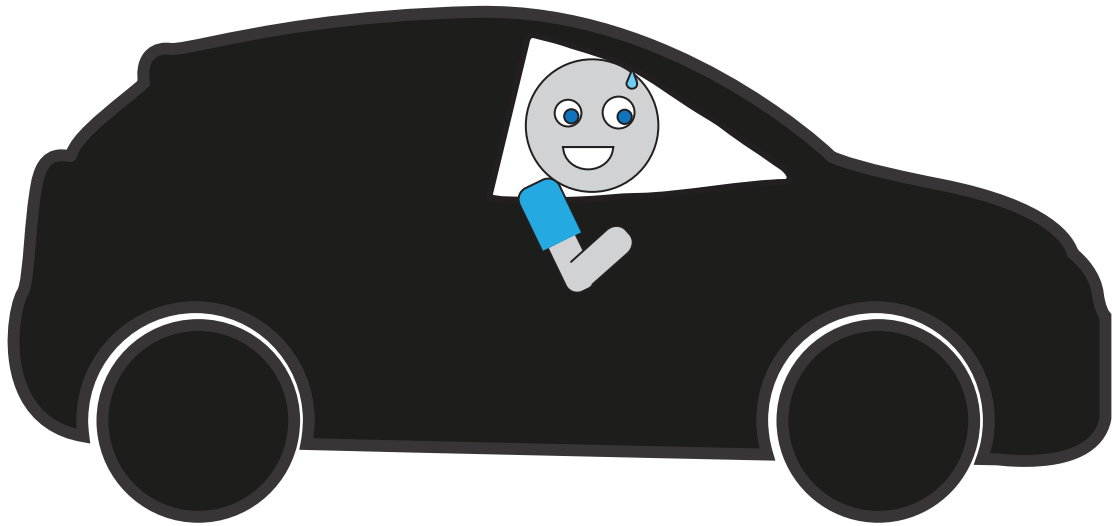

DIY IS NOT A PRODUCT

Players and coaches easily spoke to the troubles surrounding these machines. Many of them immediately saw the need for adjustability in order for this to be a useful practice machine. Others pointed out the safety and the need for portability because teams do not have storage at their practice sites.

They also mentioned that the equipment would need to be durable to survive traveling from field to home several times a week and withstand most elements.

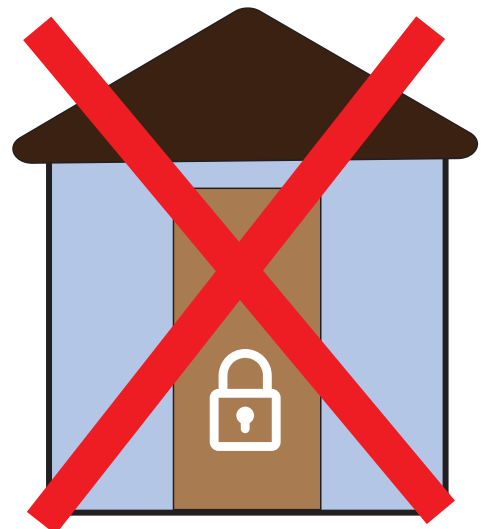
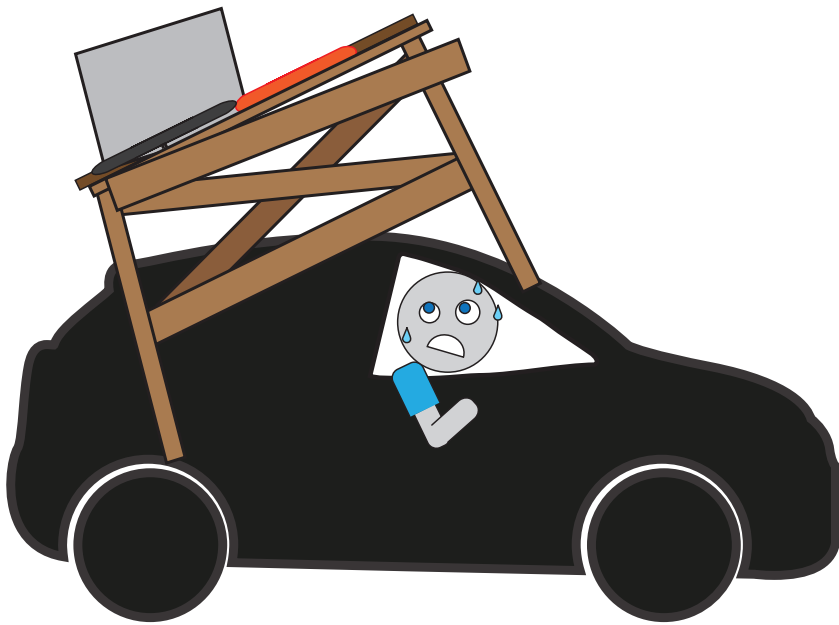

“IT WOULD BE COOL IF IT COULD BE COLLAPSIBLE”*

*Individuals response on urvey from 125 members of the ultimate community

PLAYER + MACHINE

From these machines, I was able to learn about the variety of methods people had created in order to recreate how a human throw a frisbee.

Along with how NOT to make a frisbee launcher.

But the most important take away was asking players about how they would interact with these DIY machines. Their reactions revealed many of the issues with these designs.

ANYONE HAVE A U-HAUL??

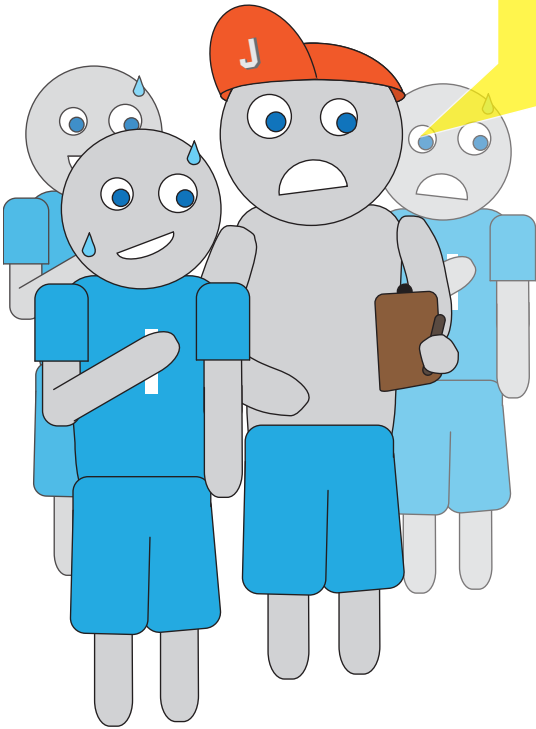

ANGLE AND SPIN

To throw a frisbee, the disc requires a certain initial velocity as well as rotational motion to create lift. The disc's design creates lift from the spin allowing it to carry through the air. Another important aspect of frisbee flight is the angle of the throw as seen in the above photos. The steeper the angle, the more choppy the flight trail making it more likely to stall in the air.

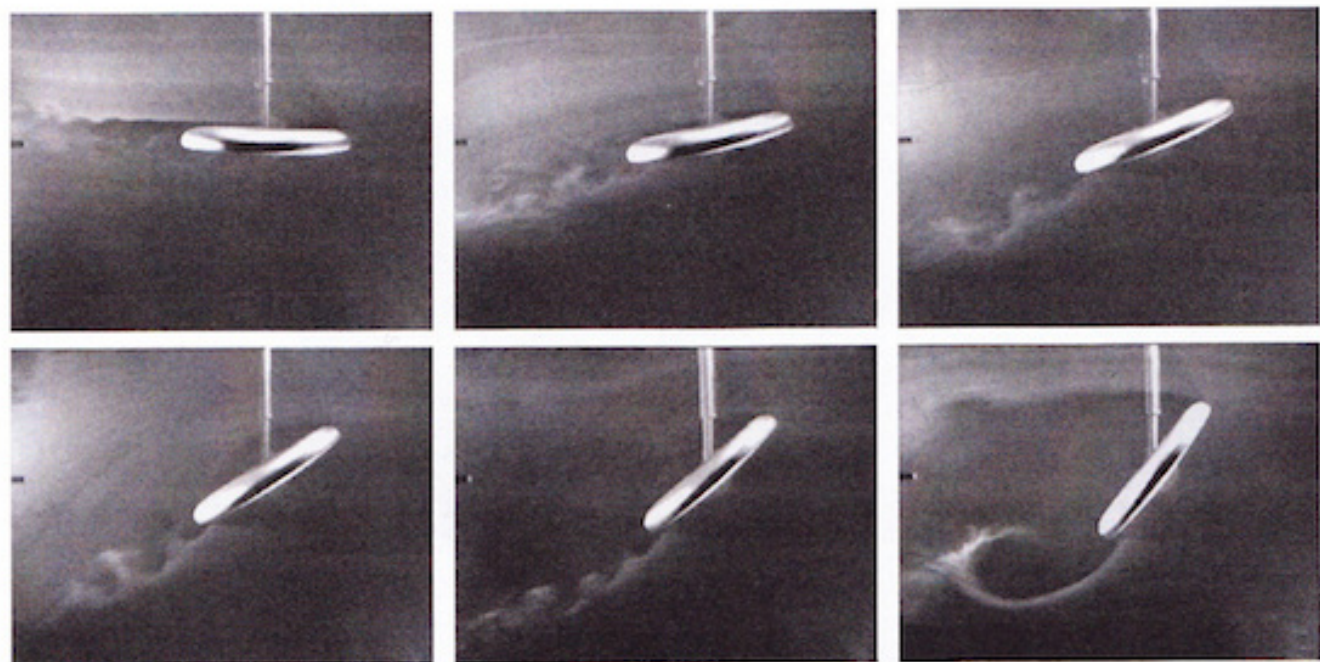

NO FRISBEE LAUNCHERS IN SIGHT

I conducted research on the existing sports training equipment market and found no existing portable frisbee launching or throwing products.

These benchmarks were important because I was able to understand these products price points and how they market their products.

MULTIPLE ROTATIONS



\$3,999



\$2689.99



\$2,100



\$1,139



\$579



\$134.99



\$115



\$209.99

\$\$\$

\$



\$1,300



\$149.99



\$119.99



\$115



\$149.99



\$8.54



\$7.99

SINGULAR ROTATION

HUCKR STANDS OUT FROM THE CROWD

Huckr is the first portable frisbee launcher of its kind. Nothing on the market like it exists allowing it to stand against no other brand in comparison.

Estimated retail value is \$275 for this 1st generation of frisbee launchers. In the future, the potential to automate Huckr and control it remotely would increase the cost. But many teams fundraise in order to pay for their equipment.



\$2,100



\$1,139



\$1,000



HUCKA



\$209.99



\$28.49

THIS IS ULTIMATE

Examples of players and their swag can be seen [here](#). These images are from tournaments such as Wildwood in Wildwood, N.J. and Fool's Fest, in V.A.



THIS IS ULTIMATE.



ULTIMATE LIKES TO STAND OUT

Not all players are created with the same level of extroverted neon colors and obnoxiousness. But a large majority is living life loud and proud. Hence just one of the few reasons ultimate is open to the LGBTQ community along with that ultimate is commonly played mixed gender.

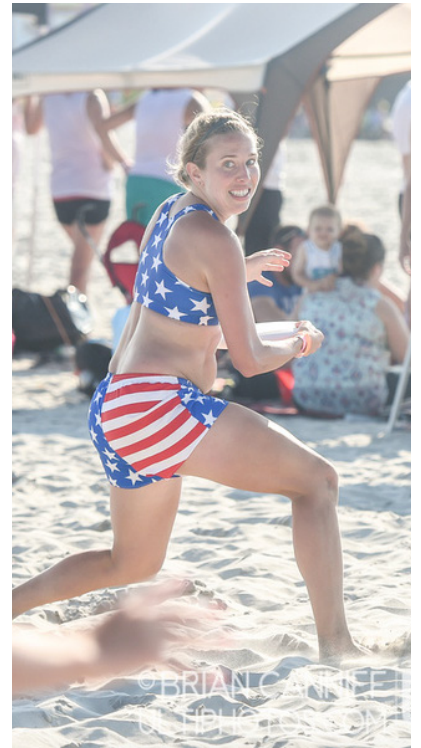

AND IT GETS WILD.



FREE SPIRITED AND COLORFUL

As I was designing Huckr, I also wanted to fully understand the consumer from a product standpoint. As a member of the ultimate community, I was able to interview players about their favorite brands for ultimate equipment.

I also wanted to understand the culture of its members. Existing products revealed a sense of humor and innate fun. Popular items feature bright color schemes and team uniforms often use puns or play on words to create their identity



Black Skeleton SS
\$45.00



Digital SS
\$45.00

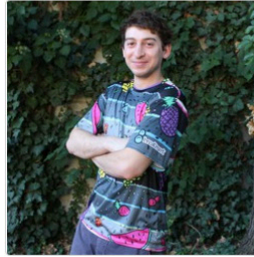

Funky Fruit SS
\$45.00



Shark Vs Bear In SPACE! SS
\$45.00



fighters. Using their depth of talent and intellect for good, the team fights crime across Flower City, and read as many R.L. Stine stories as humanly possible.
All Team Marketplace orders are treated as custom orders, therefore, all sales are final.



Rochester Ultimate Dark Jersey
\$ 35.00



Rochester Ultimate Dark Long Sleeve Jersey
\$ 39.00



Rochester Ultimate Hoodie
\$ 35.00



Rochester Ultimate Light Jersey
\$ 35.00

Text us now!

CUSTOMIZE EVERYTHING

Teams design their uniforms and discs to be unique and stand out from the crowd. More competitive teams, especially on the professional level feature a tighter color palette but still embrace the spirit of the game.

Discraft Disc



Custom Disc,
Rochester Ultimate



Discraft Disc



Ugly Duckling



Rhody Fresh



St. Johns BAM



3

PROTOTYPING & TESTING

INSPIRATION

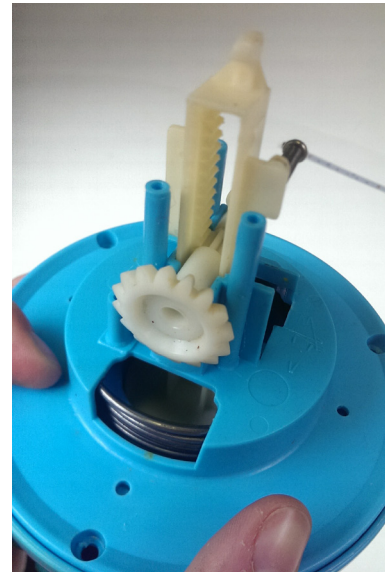

As I dove into this project, I decided to learn about the various ways to throw a disc. I took apart childrens' toys to see how they launch foam discs and eventually created my own full scale frisbee throwers.

ALL THE WAYS TO THROW A FRISBEE



Similar to the people I saw online, I tried my hand at creating rough “big uglies” that could throw a frisbee. The arm launcher on the left was able to throw the frisbee over 15 feet but the angle of the disc was hard to control.

The bike wheel thrower was able to grab the disc and reduce its travel displacement but it lacked enough energy behind its throws.

CATAPULTS TO WHEELS

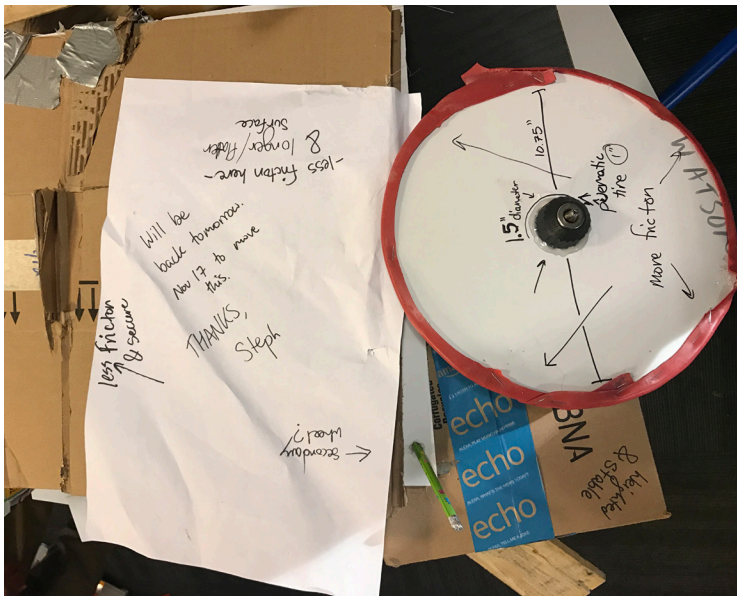

Early wheel prototypes, one using an 8' wheel and the other, a 26" bike wheel.
Both were powered by a drill motor.

On the right, I modified a skeet shooter to fit a frisbee but the results were unreliable and players felt uncomfortable setting it up. The device was also very dangerous to the shin and arms if it were no set up correctly.

BATTERY TESTING

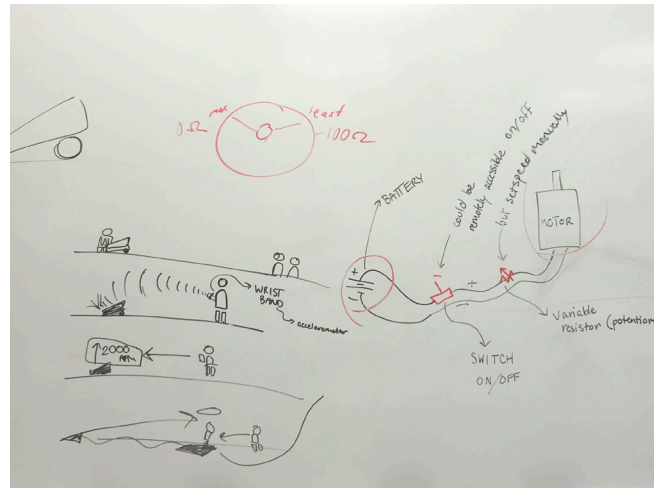

I worked with two engineers to try to create a working battery operated prototype. We learned how much power is needed to operate

COMPARING OPTIONS

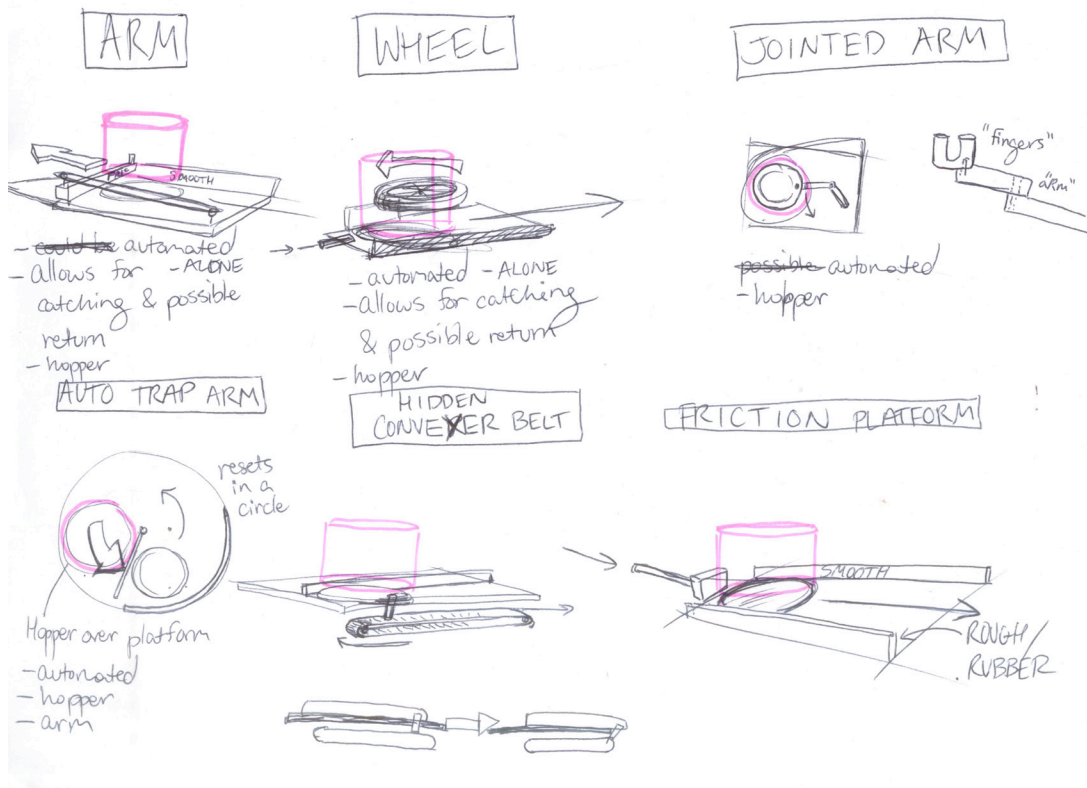

Much of my testing was documented through film but I drew out the different options to launch a frisbee and settled on using a wheel and platform to launch the disc.

4

DESIGN DEVELOPMENT



CARDBOARD TO SCALE MODELS WERE MADE TO TEST VARIOUS FEATURES.

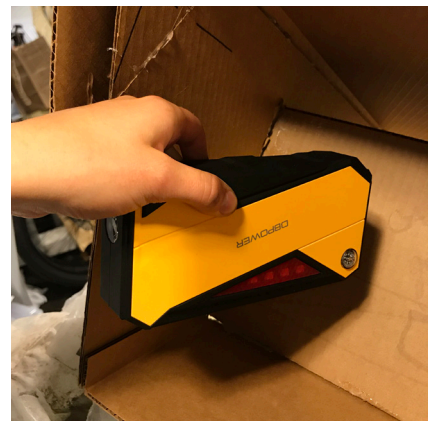
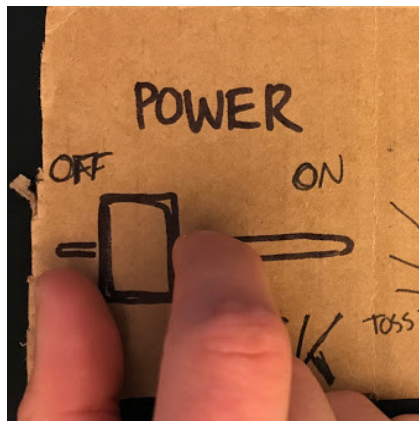

FORM & FUNCTION

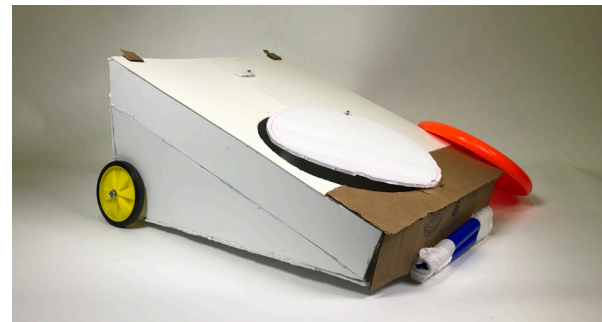
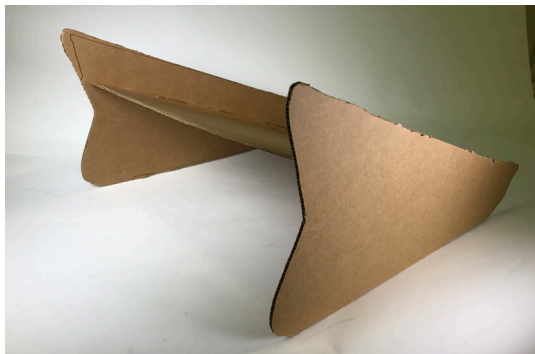

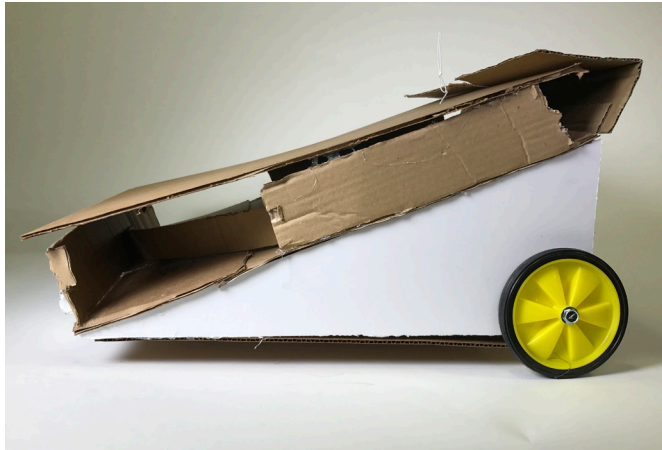

Cardboard models were created to test the form and eventually to test how players interacted with the machine and how to improve their relationship.

HANDLE

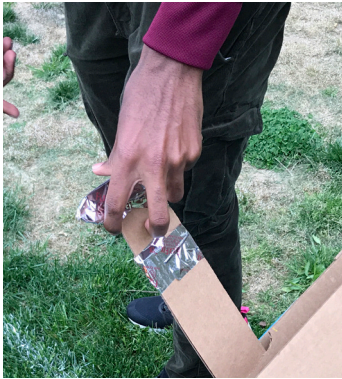

I tested slide away handles compared to telescoping handles because the machine needs to be compact.

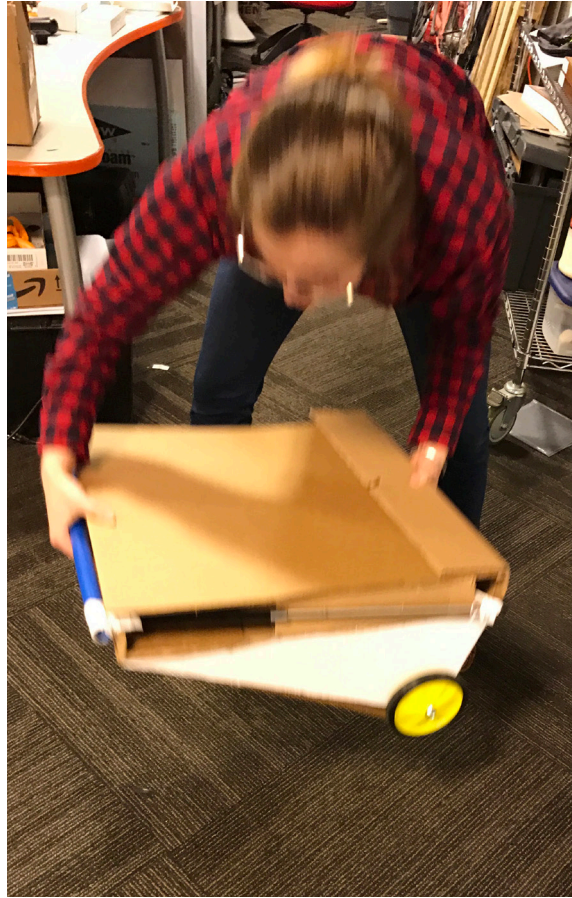

CAR STORAGE

I asked players to pick up and move the prototypes from various locations to see what was comfortable and uncomfortable.

LOADING HUCKR



I tested slide away handles compared to telescoping handles because the machine needs to be compact.



DISC STORAGE

Initial testing of including disc storage on Huckr.

THE CONTROL PANEL

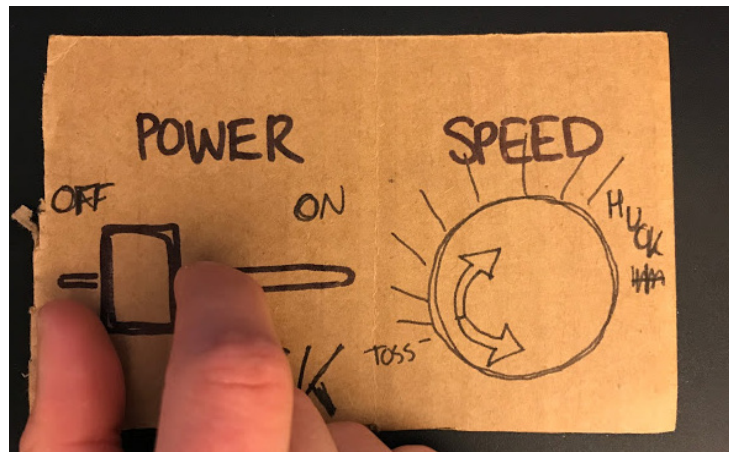

I created button interfaces for players to test. Appeal was found in the slide switch to change the power and speed.



BATTERY POWERED

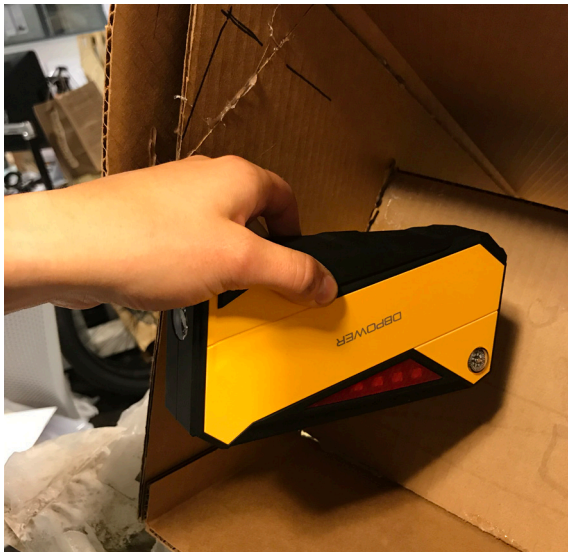

Huckr needs to be portable and this requires being able to power it in different locations. Using a 18 volt Lithium battery, Huckr can be powered for over several day time without having to be recharged. Also the battery can be charged via AC cable using a car charging outlet.

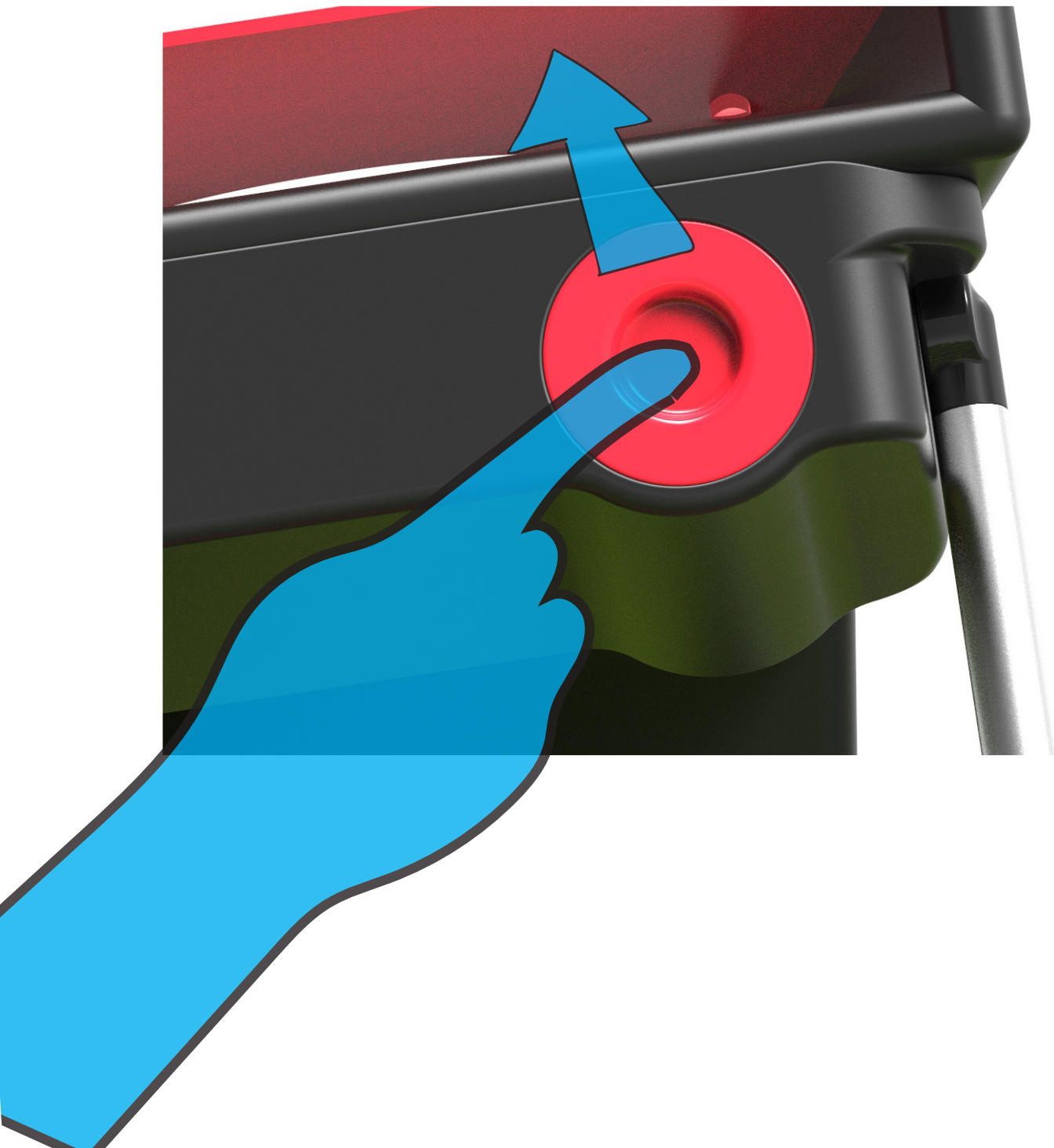

PIVOT ANGLE



I created button interfaces for players to test. Appeal was found in the slide switch to change the power and speed.



30 DEGREES



One of the mandatory criteria from surveys was that the machine must be adjustable to different angles. Without adjustability, many people believe the machine would be more of a hassle than help.



Legs also adjust individually by unscrewing them to different lengths.

5

HUCKR SPECIFICATIONS



FRONT VIEW

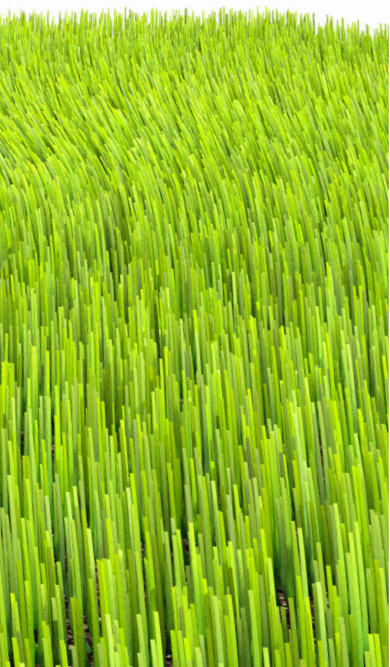

14.22"

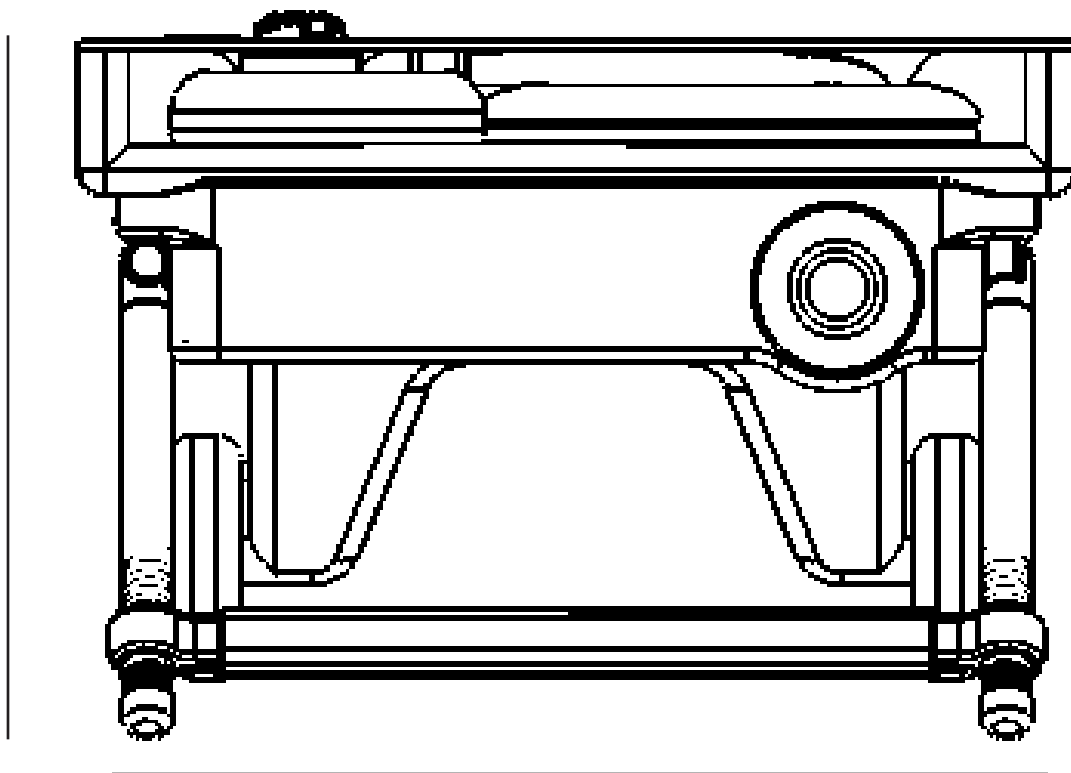

22.00"

TOP VIEW

20.02"

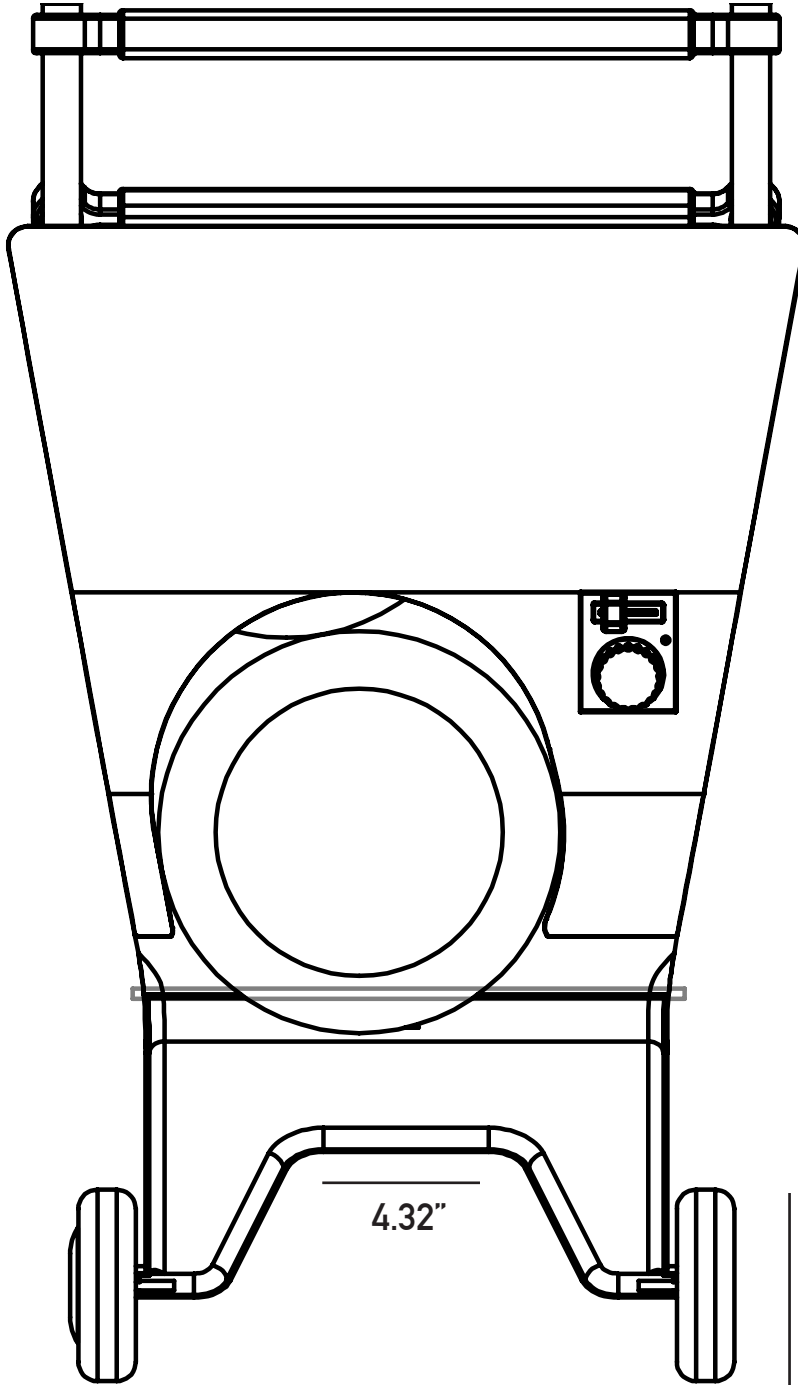

30.83"

4.32"

4.00"

14.12"

SIDE VIEW

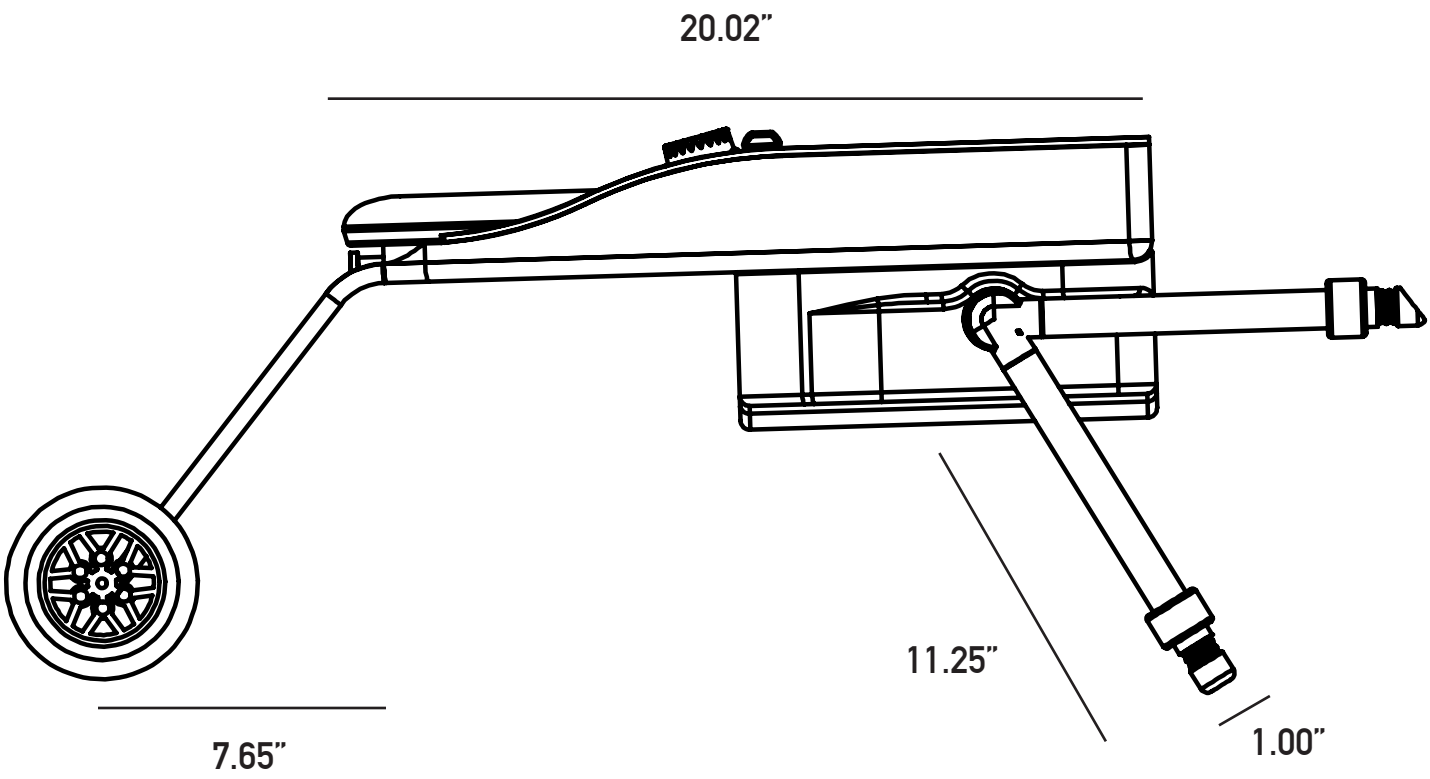

BEFORE HUCKR

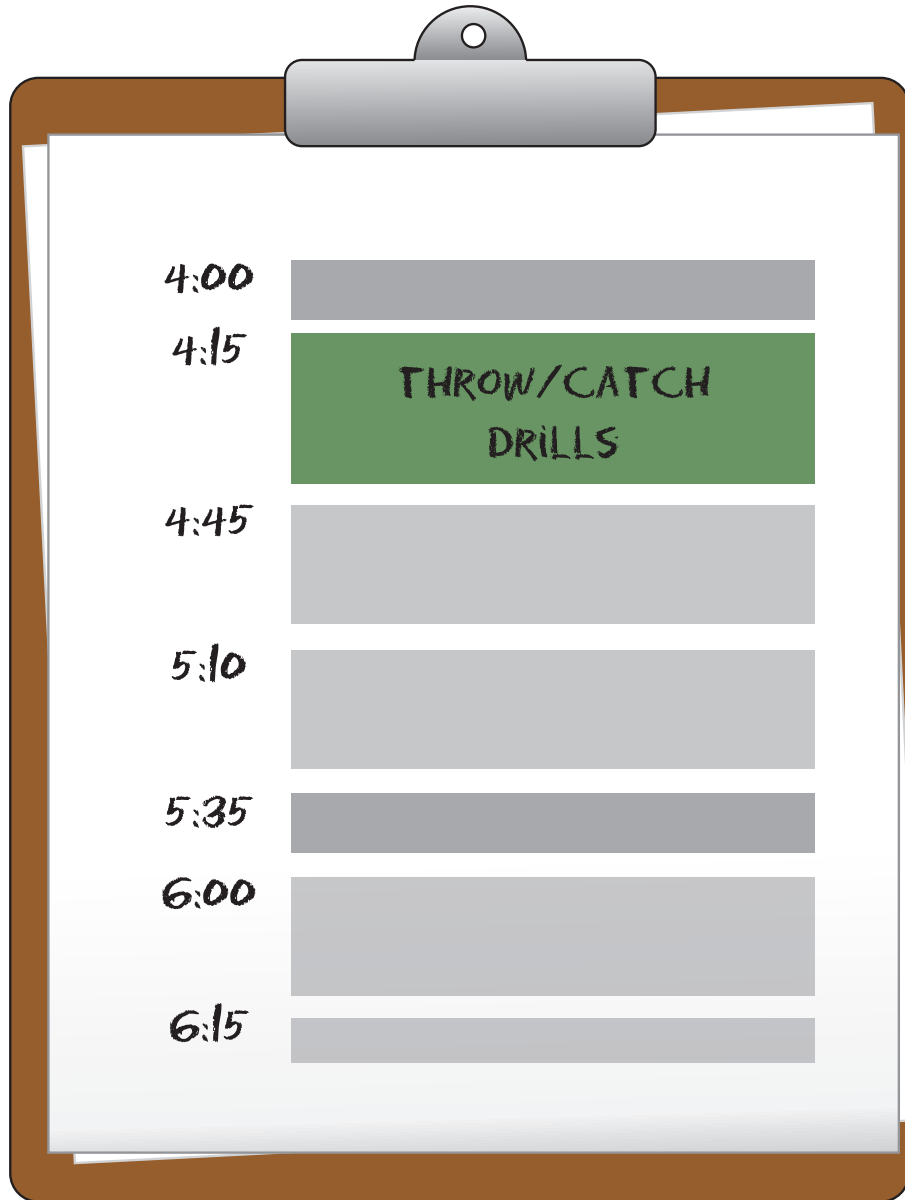

WITH HUCKR

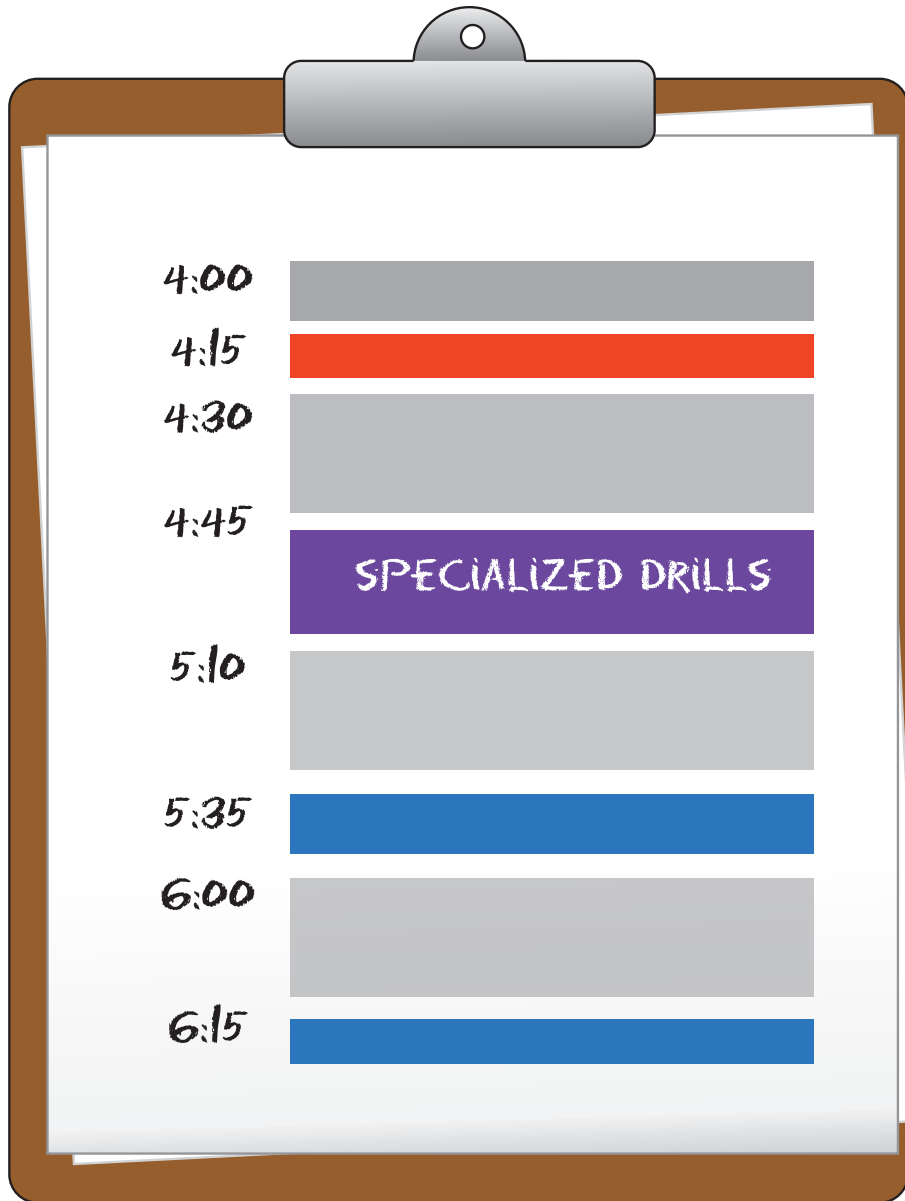

POTENTIAL RETAILERS

RETAIL PRICE: **\$ 275**

Modell's and Dicks sporting goods sell training aids for baseball and tennis. Huckr flts this niche and could also be sold on amazon allowing access to the digital market on a reputable site.



MODELL'S
SPORTING GOODS

DICK'S
SPORTING GOODS

amazon

DURABLE



Injected Molded Recycled Polypropylene

Inexpensive for large quantities
Durable



Extruded Recycled Aluminum Frame

Strong
Lightweight

Potentiometer
High Voltage Resistor
Toggle Power Switch
Splashproof Injection Molded
Electrical Housing

8" Pneumatic Tire
Differential Miter Gearbox

CIM 2.5" DC Motor

3 x 6V Lithium Ion Battery
AC/DC Car Adapter
Charger

Overmolded TPE
Soft Grip Overmold

1' Extruded Aluminum Tubing
Polypropolene Threaded Inserts and Legs

3" Hex Head Bolts

4" Pneumatic Tires

Injection Molded Snap On Hub

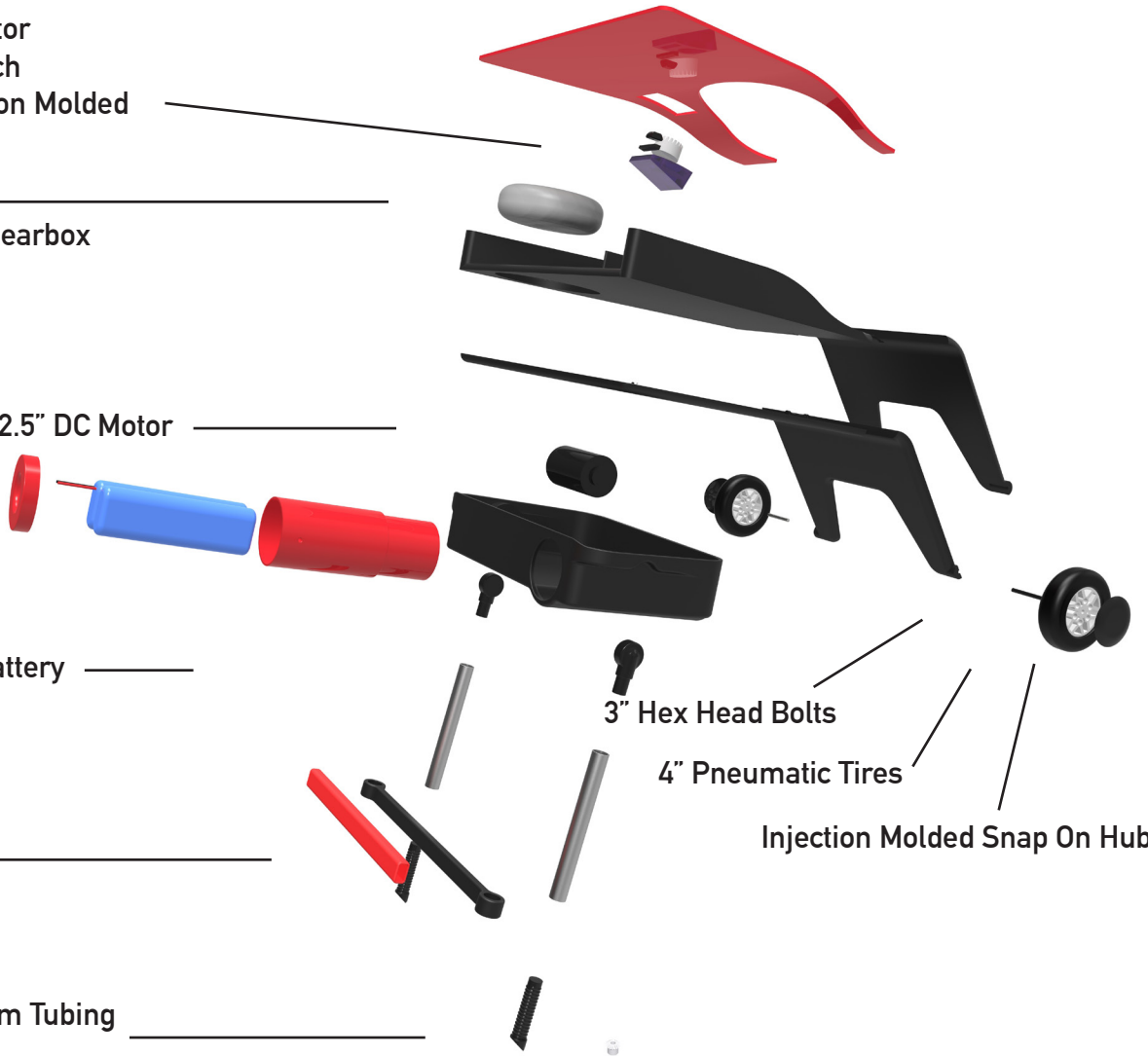

6

DEC CAPSTONE OUTCOMES

1. INTEGRATION & SKILLS

Integrate the skills and knowledge acquired through the DEC Core curriculum to propose solutions to

real-world problems, through:

- a. Strategy Identification-
- b. Formulation of value propositions-
- c. Identification and explanation of systems-
- d. Formulation of research questions-

2. SYNTHESIZE INTERDISCIPLINARY WORK

Synthesize interdisciplinary work (both collaboratively and independently) through:

- a. Proposal of solutions/hypotheses-
- b. Interdisciplinary collaboration-

3. COMMUNICATE FINDINGS

Communicate capstone experience findings effectively using multiple modes-

4. PROFESSIONAL RELEVANCE

Evaluate the relevant professional, ethical and social responsibilities associated with the capstone experience-

5. GLOBAL CONTEXT

Explain the global context of the capstone experience-

6. APPLICATIONS | TRENDS | TECHNOLOGIES

Interpret emerging applications/practices/trends/technologies as they apply to the capstone experience-

7. CAPSTONE EXPERIENCE

Relate the capstone experience to relevant contemporary issues-

THANK YOU!

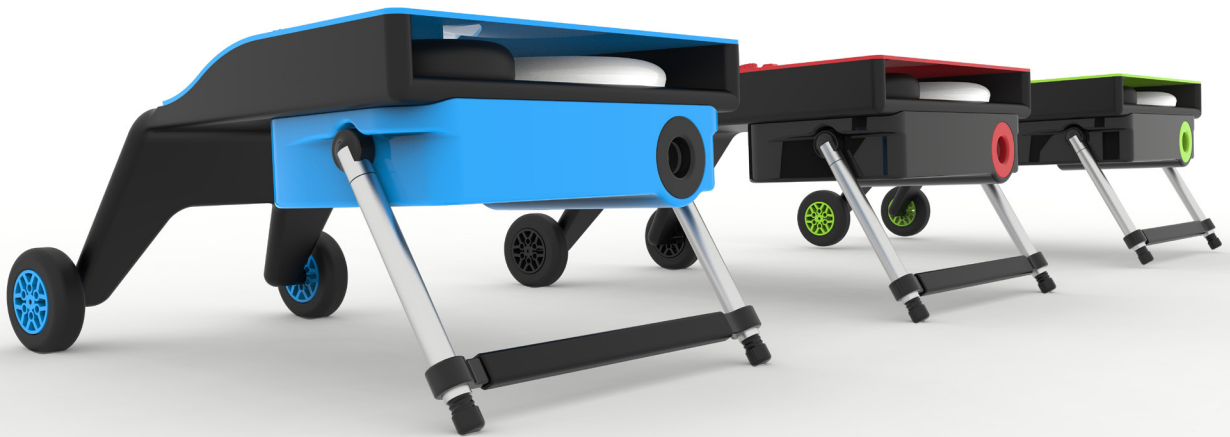

TOPHER ANDERSON

TOD CORLETT

LYN GODLEY

MARK HAVENS

TODD KRAMER

MIKE LEONARD

EILLEN MARTINSON

ERIC SCHNEIDER

JUSTIN SIEBEL

BRIAN YUST

BITMAP ULTIMATE TEAM

PHILAU ULTIMATE ALUMNI

PHILAU ULTIMATE CLUB TEAM

GREG ANDERSON

GREG FALLON

KELSY KAUSCH

KELLY WOTJAN

NICK LOPRESTO

JAMES POLLARD

CARL STANTON

SAAD TRABOULSI

SIMON Y

THE PARENTAL UNITS

SENIOR ID CLASS

ROOMIES

