

Storm water infiltration in a monitored green roof for hydrologic restoration

L'infiltration des eaux pluviales dans une toiture végétalisée instrumentée pour la restauration du cycle hydrologique naturel

Anna Palla¹, John J. Sansalone², Ilaria Gnecco¹, Luca G. Lanza¹

¹Dept. of Civil, Environmental and Architectural Engineering, Univ. of Genova
Via Montallegro 1, 16145 Genoa, Italy (panna@dicat.unige.it)

²Dept. of Environmental Engineering Sciences, Univ. of Florida
A.P. Black Hall, PO Box 116450, Gainesville, FL 32611-6450

RÉSUMÉ

Cette étude a été développée afin de fournir des informations détaillées par rapport aux performances des toitures végétales au niveau du climat méditerranéen (volume infiltré, réduction du débit maximum, retard de ruissellement) et afin de définir un modèle décrivant la réponse hydrologique associée.

Les données recueillies au cours des contrôles qui ont été menés pendant 13 mois ainsi que d'une campagne de surveillance saisonnière (septembre - décembre 2008) auprès du site expérimental de l'Université de Gênes (Italie) où la toiture végétale a été développée, sont décrites dans ce document ainsi que les résultats concernant la performance hydrologique de la toiture végétale.

Afin d'examiner la réponse hydrologique de la toiture, on a utilisé le modèle SWMS_2D qui résout l'équation de Richards dans un milieu saturé et insaturé en deux dimensions. Les résultats du processus confirment la pertinence du modèle SWMS_2D afin de décrire correctement la réponse hydrologique des toitures végétales. Le modèle reproduit correctement les hydrogrammes. De plus, le profil du taux de saturation du sol correspond aux valeurs observées le long d'un profil vertical pour lequel les mesures sont disponibles.

ABSTRACT

The objectives of this study are to provide detailed information about green roof performances in the Mediterranean climate (retained volume, peak flow reduction, runoff delay) and to identify a suitable modelling approach for describing the associated hydrologic response.

Data collected during a 13 - month monitoring campaign and a seasonal monitoring campaign (September to December 2008) at the green roof experimental site of the University of Genova (Italy) are presented in the paper, together with results obtained in quantifying the green roof hydrologic performances.

In order to examine the green roof hydrologic response, the SWMS_2D model, that solves the Richards' equation for two-dimensional saturated-unsaturated water flow, has been implemented. Modelling results confirm the suitability of the SWMS_2D model to properly describe the hydrologic response of the green roofs. The model adequately reproduces the hydrographs, furthermore, the predicted soil water content profile generally matches the observed values along a vertical profile where measurements are available.

KEYWORDS

Green roof, hydrologic restoration, storm water, detention, two-dimensional unsaturated model

1 INTRODUCTION

Traditional storm water management practices mainly rely on conveyance to route storm water runoff from urban impervious surfaces towards the nearby natural water bodies. Dedicated facilities are designed to mitigate the effects of the increased runoff peaks, volumes, and velocity. More recent concepts in urban storm water management, such as Sustainable Urban Drainage Systems (SUDS), Low-Impact Development (LID) technologies or Water Sensitive Urban Design (WSUD), aim at restoring the critical components of natural flow regimes. In particular, such techniques are designed to capture, temporarily retain and infiltrate storm water (e.g. rain barrels, biofiltration swales, pervious pavements, green roofs), promote evapotranspiration and harvest water at the source, encouraging in general evaporation, evapotranspiration, groundwater recharge and the re-use of storm water (Villareal et al., 2004).

In this framework green roofs provide a way for rooftops to be converted in pervious areas and used beneficially rather than contributing to storm water management problems (Fioretti et. al, 2010). Green roofs are constructed of a lightweight soil media, underlain by a drainage layer, and a high quality impermeable membrane to protect the building structure. The basic roof technology components, starting at the concrete slab interface, generally include: the waterproof-root repellent membrane; the drainage layer (realized with either engineered coarse grained porous media or plastic profiled elements), the filter membrane (geotextile), the growing medium (a blend of mineral material enriched with organic material) and the vegetation layer.

Green roofs are increasingly being used as a source control measure for urban storm water management as they detain and slowly release rainwater (Carter and Jackson, 2007; Mentens et al., 2006). In particular, thanks to their water storage capacity, green roofs may significantly mitigate the runoff generation of most rainfall events. The mitigation consists in delaying the initial time of runoff due to the enhanced infiltration of water in the green roof system, reducing the total outflow volume by retaining part of the rainfall and evapo-transpiring through vegetation, and distributing the outflow over a longer time period thanks to a relatively slow release of the excess water that is temporarily stored in the high porosity structure of the growing and drainage layers.

The volume retention is mainly affected by the thickness of the stratigraphy, the hydraulic properties of the green roof components and partially by the vegetation typology and density. From data published in the literature it is evident that a green roof system is able to significantly reduce the generation of storm water runoff, with volume retention scores in the order of 40-80% of the total rainfall volume (Bengtsson, 2005; Monterusso et al., 2004; Van Woert et al., 2005). The magnitude of peak attenuation mainly depends on the rainfall intensity, rainfall duration and the antecedent soil moisture conditions. However the detention capacity can be increased with increasing the substrate depth, with lowering the slope and selecting optimal technical solutions. It has been shown (Getter et al., 2007) that a decrease of 60%-80% in storm water runoff peak rates is to be expected from a green roof.

2 METHODS

2.1 The green roof experimental site

The rooftop of the Environmental Engineering laboratory building, at the University of Genova (Italy) is essentially a flat roof on three different levels, with an overall surface area of approximately 1000 m². In May 2007 a new substrate system was realized, on the central portion of this green roof, with an extension of about 350 m². The new solution consists of a protection layer (300 gr/m² geotextile), a drainage layer (realized with Lapillus for a depth of 15 cm), a filter layer (100 gr/m² geotextile) and a growing medium with mixed soil (lapillus, pumice, zeolite and 200 l/m³ of peat for a depth of 20 cm). The material employed for the growing layer is named Vulcaflor. These graded porous media are employed in green roof systems for their porosity and low bulk density. In general native clayey soils should not be used on a green roof system due to their moist weight and tendency to undergo primary and secondary consolidation.

The experimental site is a modern technological system fully equipped with sensors for on-site meteorological, hygrometric and flow rate measurements. In particular, the site is equipped with a meteorological station, operating since 1988, which collects rainfall data at one minute resolution. For research purposes, the central plot was divided into two equal halves, one of which (surface area equal to 170 m²) was instrumented in August 2008 and equipped with a set of TDR (Time Domain Reflectometry) probes and a suitable continuous monitoring system for the subsurface outflow.

Following the overall flow pattern illustrated in Figure 1, the subsurface flow corresponding to the instrumented rooftop area is drained by three outlet sections and conveyed to the flow gauging station. Subsurface water flow measurements are available at one minute resolution in time. Based on the rooftop slope and the position of the outlet sections, the monitored area can be divided into three sub-catchments. In the centre of the largest subcatchment, four TDR probes have been installed along a vertical profile as shown in Figure 1 (two in the growing layer and two in the drainage layer). The TDR probes are installed at 33 cm (TDR4) and at 22 cm (TDR3) in the Vulcaflor layer; while at 13 cm (TDR2) and 4 cm (TDR1) in the Lapillus layer (see Figure 1). The soil water content is derived from these measurements at one minute resolution by using the Topp equation (Topp et al., 1980).

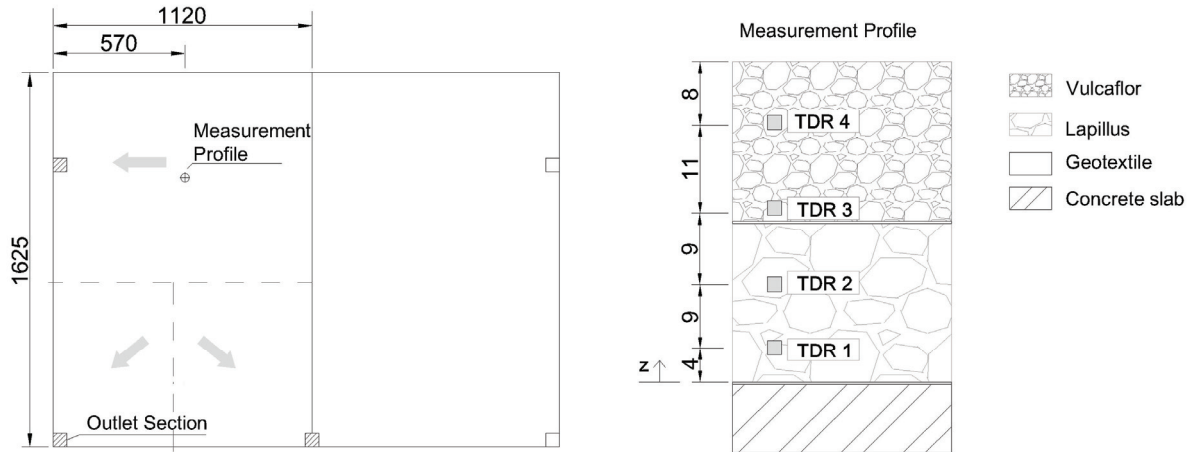

Figure 1. Plan view of the experimental site at the University of Genova (Italy) and scheme of the measurement vertical profile with distances expressed in centimetres.

2.2 The unsaturated two dimensional model

The SWMS_2D model (Simunek et al., 1998) was employed to simulate the infiltration process and water content profiles in 2D variably saturated media. The governing flow equation is the two-dimensional form of the Richards' equation:

$$\frac{\partial \theta(\psi)}{\partial t} = \frac{\partial}{\partial x_i} \left[K(\psi) \cdot \left(K^A_{ij} \frac{\partial h}{\partial x_j} \right) \right]$$

where θ is the volumetric water content [L^3L^{-3}]; ψ is the suction head [L]; $h = \psi + z$ is the pressure head [L]; K is the hydraulic conductivity function [LT^{-1}] and K^A is the dimensionless anisotropy tensor [-]. To obtain the hydraulic conductivity function in terms of soil water retention parameters, the Van Genuchten (1980) soil-hydraulic functions with the statistical pore distribution model of Mualem (1976) are implemented. The Van Genuchten relationships are:

$$\theta(\psi) = \begin{cases} \theta_r + \frac{\theta_s - \theta_r}{\left[1 + |\alpha\psi|^n\right]^m} & \psi < 0 \\ \theta_s & \psi \geq 0 \end{cases}$$

$$K(\psi) = K_s S_e^{1/2} \left[1 - \left(1 - S_e^{1/m} \right)^m \right]^2$$

where θ_r and θ_s are the residual and saturated water content [L^3L^{-3}]; $S_e = (\theta - \theta_r) / (\theta - \theta_r)$ is the effective saturation; α is an empirical constant; n and m are the dimensionless parameters with $m = 1 - 1/n$ and K_s is the saturated hydraulic conductivity [LT^{-1}].

The numerical model requires to estimate six parameters (θ_r , θ_s , α , n , K_s , K^A). In addition the code requires input specifications for the finite-element mesh, as well as the associated initial and boundary conditions. The Galerkin finite element method with linear basis functions is used to obtain the solution of the flow equation subject to the imposed initial and boundary conditions. The simulation domain is

1120 cm (wide) while the depth ranges between 46.3 cm and 27.7 due to the bottom slope equal to about 2%. The stratigraphy is represented in the simulation domain by the overlapping of three homogenous and anisotropic porous media: from the top to the bottom, Vulcaflor, geotextile and Lapillus. The geotextile is modelled as an equivalent porous media whose saturated hydraulic conductivity represents the flow resistance of the non woven fabric. The drainage (outlet) is schematized in the simulation domain with a condition of free-drainage assigned to the bottom left corner for 50 cm in the horizontal direction and 23 cm (the thickness of the drainage layer) in the vertical direction. The generic element for Lapillus and Vulcaflor is 5 cm (wide) × 5 cm (high) while the geotextile generic element is 5 cm (wide) × 0.1 cm (high). The minimum-sized element (a boundary condition element) is 1cm (wide) × 1 cm (high). The generic element sizes for Lapillus and Vulcaflor are approximately ten times larger than the d_{50} values.

The boundary conditions at the soil-atmosphere interface may change from a prescribed flux (unsaturated soil conditions) to a prescribed head type condition (for saturated soil). In case of unsaturated soil ($\psi_{x,z} < 0$) the boundary conditions are given by:

$$\left| K(\psi) \left(-K_{zz} \frac{\partial \psi}{\partial z} - K_{zz} \right) \right| = P$$

$$\left| K(\psi) \left(-K_{xx} \frac{\partial h}{\partial x} \right) \right| = 0$$

with P the precipitation [LT^{-1}]; while for saturated soil conditions: $\psi_{x,z} = 0$. At the outlet, a zero head condition (free-drainage) is set at the boundary while at the soil-concrete slab interface a zero flux condition is imposed. The initial conditions for each simulated event are assigned in terms of water content at the beginning of rainfall. At the outlet section the initial water content is assumed to equal the residual moisture content, while in the flow field it is specified using data measured by the TDR probes. In particular, the initial water content is assumed to equal the value measured at TDR4 for all nodes at depth $z \geq 30$ cm, at TDR3 for all nodes at $20 \leq z < 30$ cm, at TDR2 for all nodes at $10 \leq z < 20$ cm and at TDR1 for all nodes at $z < 10$ cm.

3 RESULTS AND DISCUSSION

3.1 The hydrologic performance of the green roof experimental site

3.1.1 The first phase of the monitoring campaign

The first phase of the monitoring campaign was carried out from the 22nd of May 2007, after installation of the new green roof was completed, to August 2008, when the TDRs have been installed. In this phase the subsurface flow corresponding to the whole green roof is conveyed to the gauging station. The hydrologic behaviour of the experimental green roof in the Mediterranean town of Genoa was examined on an event by event basis over a thirteen-month period.

In Table 1 the total rainfall depth and the flow peak rate together with the synthetic variables used to quantify the green roof hydrologic performance are summarised for each rainfall event. These are reported on a event basis and for the whole monitoring campaign, in terms of mean and standard deviation values. The green roof hydrologic performance are expressed in terms of retained volume, peak flow reduction and outflow hydrograph delay. The retained volume is calculated as the absolute percentage difference between the outflow and rainfall depths, while the outflow delay is determined as the difference in time between the hydrograph and hyetograph centroids. In order to calculate the peak flow reduction a model of the impervious roof was implemented so that a reference rooftop behaviour is made available for comparison purposes. The peak flow reduction is then calculated as the percentage difference between the outflow peak of the green roof and the reference impervious roof. The reference impervious rooftop was simulated by employing the EPA Storm Water Management Model (SWMM 5.0 – Huber and Dickinson, 1992). The flow routing method is based on the kinematic wave model and the runoff production model is the Soil Conservation Service Curve Number method (SCS, 1972). Detailed modelling results, including calibration and validation procedures, are illustrated elsewhere (Palla, 2009).

Four out of the nineteen rainfall events monitored did not produce any subsurface runoff, five produced subsurface runoff with a peak flow lower than 0.1 l/s, and only three events produced a significant subsurface runoff with peak flows greater than 1 l/s. In all events the rainfall volume was

completely infiltrated (no surface runoff occurred) and only partially exfiltrated. The peak flow reduction values range between 50% and 100% with an average value of 89%; the retained volumes vary from 5% to 100% with an average value of 68%. As for the events producing an outflow peak greater than 1 l/s, the observed runoff delay was equal to 79 min for the 5 June 2007 event, 148 min for the 22-23 November 2007 event and 91 min for the 17 June 2008 event. These delay values are relevant in view of the usual concentration times of urban catchments. The performance of the green roof as a device for storm water control appear excellent, with average retained volume and peak reduction respectively equal to 68% and 89%. From these data it clearly emerges that a green roof system is able to significantly reduce storm water runoff generation - even in the Mediterranean region - in terms of runoff volume reduction, peak attenuation and increase of concentration time. Extension of these results to the spatial scale of the urban watershed is needed to assess the role of green roof installations in preventing flooding phenomena in the urban areas and limiting the impact of storm water on waste water treatment plants (see e.g. Carter and Rasmussen, 2006).

Rainfall Event	Rain Depth (mm)	Flow Peak (l/s)	Retained Vol. (%)	Peak Reduction (%)	Delay (min)
26 May 2007	9	No outflow	100	100	-
28 May 2007	12.4	No outflow	100	100	-
1 Jun. 2007	42.4	0.02	99	99	345
5 Jun. 2007	41.2	1.31	41	87	79
8 Aug. 2007	13.2	No outflow	100	100	-
9-10 Aug. 2007	14	< 0.01	95	98.7	793
20 Aug. 2007	15.2	< 0.01	95	99.9	89
21 Aug. 2007	32.6	0.04	96	99	436
27 Aug. 2007	28.6	0.02	99	99.6	150
21 Nov. 2007	8	No outflow	100	100	-
22-23 Nov. 2007	138.2	1.27	9.5	79	148
4-5 Jan. 2008	32.8	0.1	70	76	754
11-12 Jan. 2008	41.4	0.6	15	87	427
16 Jan. 2008	40.4	0.9	4.6	78	139
4 Feb. 2008	30.4	0.8	51	70	197
9-10 Mar. 2008	23.2	0.16	81	94	596
9-11 Apr. 2008	55	0.1	93	96	1716
21 Apr. 2008	25.4	0.62	23	46	145
17 Jun. 2008	35.6	1.2	19	77	91
<i>Mean</i>	-	-	68	89	407
<i>Std. Dev.</i>	-	-	37	15	435

Table 1: Hydrologic characteristics of the rainfall events and green roof hydrologic performance (reporting the retained volume, the peak flow reduction and the delay of the hydrograph centroid with respect to the hyetograph centroid) observed at the experimental site during the first phase of the monitoring campaign.

3.1.2 The second phase of the monitoring campaign

The second phase of the monitoring campaign was carried out from August 2008 and is still in progress. In Table 2 the total rainfall depth, duration, Antecedent Dry Weather Period (ADWP) and flow peak rate are summarised for each rainfall event together with the synthetic variables used to quantify the green roof hydrologic performance. The synthetic variables used to quantify the green roof hydrologic performance are reported on an event basis and for the whole monitoring campaign, in terms of mean and standard deviation values.

One out of the ten monitored events produced no subsurface outflow, three events had runoff peaks greater than 0.5 l/s and only two events produced a relevant subsurface outflow greater than 1 l/s. In all events the rainfall volume was completely infiltrated (no surface runoff occurred) and only partially exfiltrated. Note that the maximum recorded peak flow is equal to 2.1 l/s. Moreover, the relevant delays (149 min on average) confirm the potential role of the green roof as a source control system for storm water runoff. With reference to the hydrologic characteristics of the examined rainfall events and to their seasonality, the observed hydrologic performance demonstrate that the green roof is able to

mitigate the generation of storm water runoff in terms of outflow volume reduction, peak flow attenuation and increase of the time of concentration. However, performance are reduced with respect to the above illustrated monitoring campaign, since they are referred to a particularly rainy season. The antecedent dry weather period, reported in Table 2 for all the events, is the hydrologic characteristic that controls the response of the green roof. In the autumn season, when the role of evapotranspiration during the inter-event period is limited due to the environmental conditions, an antecedent dry weather period lower than 96 h is not sufficient to dry the system: for all the events with ADWP lower than 96 h and 12 h the volume reduction is lower than 20% and 0% respectively (see Table 2). Indeed, at the event scale, if the initial water content is greater than the field capacity, the substrates of the green roof are not able to store permanently or reduce the storm water volume (Bengtsson, 2005). On the contrary for any initial soil water content, the substrates of the green roof are able to temporary store the storm water volume, as confirmed by significantly peak reduction percentages (>40%) for all collected events.

Rainfall Event	Rain Depth (mm)	Rain Duration (h)	ADWP (h)	Flow Peak (l/s)	Retained Volume (%)	Peak Reduction (%)	Delay (min)
13 Sept. 2008	23.2	17.5	216	No outflow	100	100	-
19 Sept. 2008	28.2	10.2	96	0.2	56	69	303
22 Sept. 2008	16.6	1.5	9.5	0.38	19	84	145
28 Oct. 2008	71.6	10	48	2.1	18	52	93
29 Oct. 2008	74.8	19.2	6	1.1	0	91	71
3-4 Nov. 2008	49	21.5	9.5	0.6	0	93	118
11-12 Nov. 2008	72	47.3	10	0.86	0	61	174
29-30 Nov. 2008	76	33.0	14.5	0.22	17	44	95
9-10 Dec. 2008	98.6	26.8	96	1.0	13	52	128
16-17 Dec. 2008	32.6	18.3	9	0.2	0	72	212
<i>Mean</i>	-	-	-	-	22	72	149
<i>Std. Dev.</i>	-	-	-	-	32	20	72

Table 2: Hydrologic characteristics of the rainfall events and green roof hydrologic performance observed at the experimental site (Genoa, Italy) reporting the flow peak, the retained volume, the peak flow reduction and the delay of the hydrograph centroid with respect to the hyetograph centroid. ADWP is the antecedent dry weather period.

3.2 Modelling results

The numerical model is calibrated and validated using the events observed during the second phase of the monitoring campaign when the experimental site was equipped with the TDR probes. The selected rainfall-runoff events were collected from September to December 2008 and are characterized by an outflow peak ranging between 0.2 and 2.1 l/s (see Table 2). The calibration and validation strategy is based on the comparison of the predicted and measured subsurface flow hydrographs. In particular, three variables are used to this aim: the discharge volume, the peak outflow rate and the hydrograph centroid. The rainfall events used in the calibration phase are those observed on 29 October, 4 November, 9-10 December and 16-17 December 2008, while the other ones are used in the validation procedure. In order to assess the model performance with respect to the above mentioned hydrograph variables, the relative percentage difference (RPD) was calculated as the ratio of the difference between the simulated and the observed values to the observed one for each rainfall event.

The hydraulic parameters (θ_r , θ_s , α , n , K_s , K^A) required by the infiltration model for each green roof component are listed in Table 3. The Vulcaflor is modelled as a loamy sand and the α and n values are taken from literature data according to Carsel and Parrish (1988). The α and n values for the Lapillus refer to a coarse sand according to Ippish et al. (2006). The θ_s , θ_r , K_s and K^A parameters were calibrated and validated using the nine selected events. Note that from the calibration procedure the anisotropy of volcanic porous media (Vulcaflor and Lapillus) emerges and such characteristic can be partially ascribed to the typical laying methods of the green roof components.

	θ_r (m^3/m^3)	θ_s (m^3/m^3)	α (1/cm)	n (-)	K_s (cm/s)	K_{xx} (-)	K_{zz} (-)	$K_{xz} = K_{zx}$ (-)
Vulcaflor	0.165	0.4	0.124	2.28	0.08	10	1	0
Geotextile	0.165	0.4	0.124	2.28	0.008	1	1	0
Lapillus	0.155	0.56	0.079	6.97	0.33	10	1	0

Table 3: Hydraulic parameters for the green roof components.

Modelling results consist in the pattern of the soil water content within the simulation domain and the specific subsurface outflow from the two-dimensional outlet section at each time step. The effluent hydrograph is derived by adding each specific outflow along the cross section and neglecting the convection in the drainage pipes due to the short distance involved. The quantitative assessment of model performance is summarized in Table 4, where the Nash-Sutcliffe model efficiency index (Nash and Sutcliffe, 1970) and the relative percentage difference (RPD) for the total effluent volume, the flow peak rate and the hydrograph centroid are reported. Note that a Nash-Sutcliffe efficiency index equal to 1 indicates a perfect match between the predicted and observed outflow. Results confirm the suitability of the model to properly describe the hydrologic response of the green roof during the observed rainfall events, characterized by peak flow values ranging from 0.2 to 2 l/s. The hydrographs characterized by a single peak flow as well as more complex shape - long lasting hydrographs are properly reproduced as confirmed by the Nash-Sutcliffe model efficiency index values close to 1.

Rainfall Event	Nash Sutcliffe (-)	RPD		
		Volume (%)	Peak (%)	Centroid (%)
19 Sept. 2008	0.87	33	0	12
22 Sept. 2008	0.81	46	-19	38
28 Oct. 2008	0.98	15	6	-4
29 Oct. 2008 ^C	0.95	-11	-7	-3
4 Nov. 2008 ^C	0.97	-9	-6	2
11-12 Nov. 2008	0.97	-11	-5	-5
29-30 Nov. 2008	0.92	2	-35	2
9-10 Dec. 2008 ^C	0.97	12	-7	2
16-17 Dec. 2008 ^C	0.93	1	-10	-3

Table 4: Nash-Sutcliffe efficiency coefficient and relative percentage deviation (RPD) of the total effluent volume, peak flow rate and the hydrograph centroid for the observed rainfall events. The superscript 'C' denotes the calibration events.

The RPD of the total effluent volume varies within a range of $\pm 15\%$; the timing between the simulated and the observed hydrographs is satisfactory while the model generally underestimates the peak flow rate. In the calibration procedure, the suitability of the total volume prediction has been favoured with respect to the other hydrological variables since the monitoring campaign pointed out a significant variability of volume retention performance depending on the specific rainfall characteristics. On the other hand the predicted peak flow rate tends to be underestimated thus determining an overestimation of the peak reduction performance. However the observed values (see Tables 1 and 2) proved the high performance even taking into account the error on the peak flow prediction.

The hyetograph and the corresponding simulated and measured hydrographs together with the vertical profile of the soil water content are illustrated for the 28 October 2008 event (see Figure 2). This is the most significant rainfall event observed at the field experimental site in terms of both rainfall intensity and peak flow rate (see Table 2). In Figure 2 the predicted vertical profile of the soil water content and the corresponding values of the water content measured at four depths are plotted and compared at the most significant time steps. The selected time steps refer to the beginning and the end of the hydrograph (t_i and t_f), the peak flow rate (t_p) and the time steps corresponding to 2 and 75% of the effluent volume ($t_{2\%}$ and $t_{75\%}$). In each graph, the physical range of the soil water content, ranging from the residual water content to saturation is delimited by the vertical dashed lines. The predicted soil water content profile generally matches the observed values, in particular the model properly reproduces the soil water content at the rising limb of the hydrograph (from $t_{2\%}$ to t_p). During

the decreasing limb of the hydrograph some delay of the predicted hydrologic response can be observed, thus causing the persistency of high water content values (close to saturation) in the vicinity of the concrete slab.

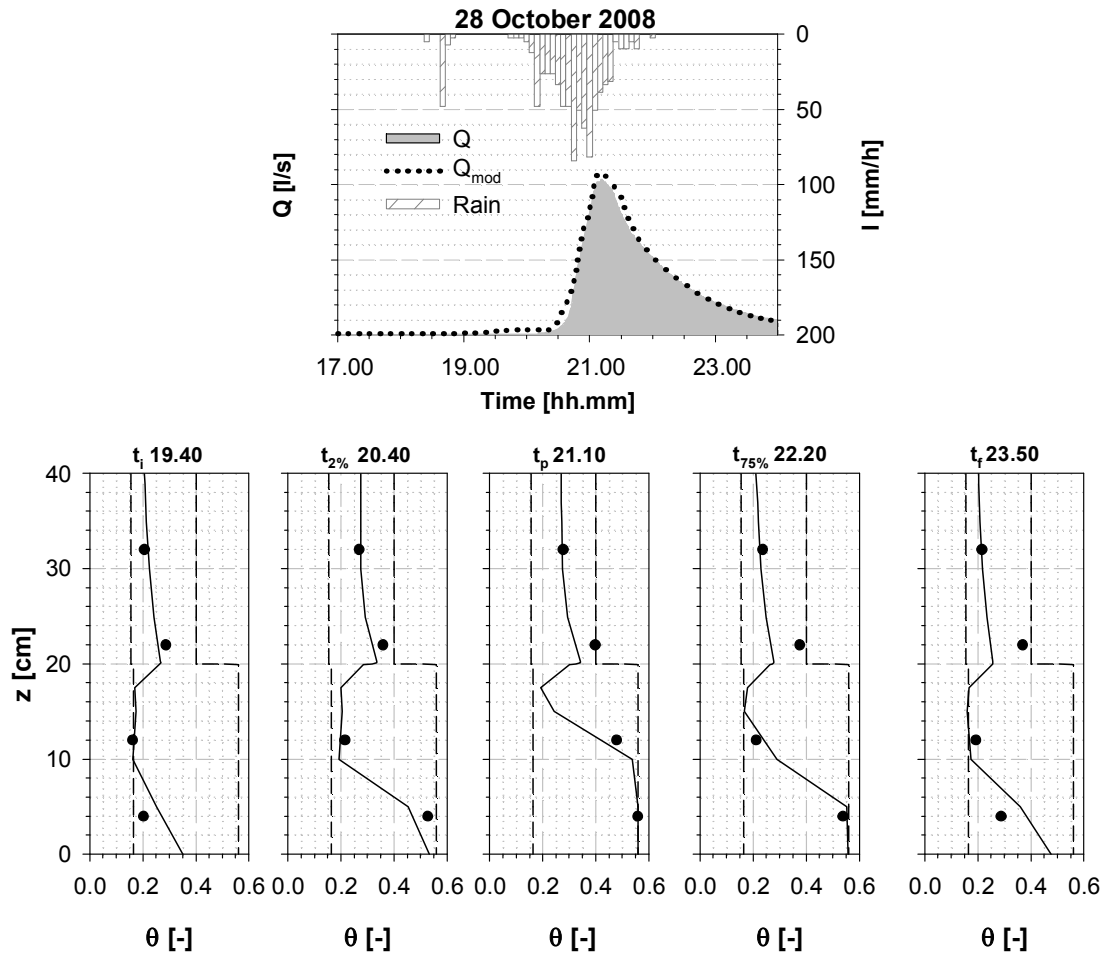

Figure 2: The hyetograph, the corresponding measured and simulated hydrographs and the comparison between the predicted vertical profile of the soil water content (continuous line) and the corresponding values at the four levels of measurement (dots) for the 28 October 2008 rainfall event.

Rainfall Event	RMSE			
	TDR4 (-)	TDR3 (-)	TDR2 (-)	TDR1 (-)
19 Sept. 2008	0.0002	0.0041	0.0002	0.0026
22 Sept. 2008	0.0002	0.0079	0.0002	0.0016
28 Oct. 2008	0.0011	0.0007	0.0001	0.0006
29 Oct. 2008	0.0001	0.0130	0.0012	0.0037
4 Nov. 2008	0.0002	0.0101	0.0011	0.0035
11-12 Nov. 2008	0.0002	0.0118	0.0008	0.0042
29-30 Nov. 2008	0.0003	0.0096	0.0010	0.0037
9-10 Dec. 2008	0.0006	0.0094	0.0012	0.0057
16-17 Dec. 2008	0.0003	0.0134	0.0009	0.0012

Table 5: RMSE (root mean square error) of the soil water content at soil depths where the four TDR probes are located, reported for each rainfall event.

The predicted soil water content observed throughout the whole simulation domain clearly reveals the different hydraulic behaviour between the growing medium (top layer) and the drainage layer (bottom layer). In the upper layer which is basically controlled by the geotextile flow resistance, the wetting

front remains parallel to the field surface (horizontal) and advances vertically, therefore no lateral water flow occurs, as expected. On the contrary, in the deeper layer the lateral flow is predominant compared to the vertical flow according to the high horizontal hydraulic conductivity and the rooftop slope (Palla et al., 2009). In Table 5 the root mean square error (RMSE) values of the soil water content at each investigated soil depth are summarized on an event basis. Focusing on the variability of the RMSE calculated for each TDR probe, it emerges that such index is significantly consistent across the different rainfall events thus pointing out the model reliability. The most significant RMSE values are observed for TDR3 (located into the Vulcaflor layer, immediately above the geotextile). The highest RMSE values observed for TDR3 points out that the hydraulic discontinuity between the growing and drainage layer (determined by the geotextile) is the main factor affecting the overall model performance.

4 CONCLUSIONS

Based on the experimental monitoring programme carried out at the green roof site of the University of Genova (Italy), the present study concurs to characterize the hydrologic behaviour of a green roof system. Experimental data confirm that the green roof system is able to significantly reduce storm water runoff generation, with average values of the runoff volume retention and peak flow attenuation respectively equal to 68% and 89% observed for a whole hydrologic year.

The seasonal analysis of the green roof hydrologic performance points out that even in the autumn-winter season the observed hydrologic performance, although reduced, are relevant in particular with respect to the peak flow attenuation.

In this study, the SWMS_2D model has been applied to examine the hydrological response of the green roof system. The discharge hydrograph profile, volume and timing predicted by the mechanistic model matched experimental measurements as demonstrated by the limited relative percentage deviations obtained for the total discharged volume, the peak flow and the hydrograph centroid. Furthermore the predicted water content values closely match the observed data along a vertical profile where measurements are available, thus confirming that the model correctly describes the variably saturated flow in the green roof stratigraphy.

Aiming at supporting the optimal design of green roof systems, the mechanistic model implemented in this study allows to quantify the hydrologic response of the system; indeed the layered structure and each green roof component can be designed to provide the foreseen hydrologic performance and foster hydrologic restoration in the urban environment.

LIST OF REFERENCES

- Bengtsson, L. (2005). *Peak flows from thin sedum-moss roof*. Nord. Hydrol., 36(3), 269-280.
- Carter, T.L. and Jackson, C.R. (2007). *Vegetated roofs for storm water management at multiple spatial scales*. Landsc. Urban Plan., 80(1-2), 84-94.
- Carsel, R. and Parrish, R.S. (1988). *Developing joint probability distribution of soil water retention characteristics*. Water Resour. Res., 24(5), 755-769.
- Fioretti, R. Palla, A. Lanza, L.G. and Principi, P. (2010). *Green roof energy and water related performance in the mediterranean climate*. Build. Env., DOI: 10.1016/j.buildenv.2010.03.001
- Getter, K.L., Rowe D.B. and Andresen J.A. (2007). *Quantifying the effect of slope on extensive green roofs storm water retention*. Ecol. Eng., 31 (4), 225-231.
- Huber, W.C. and Dickinson, R.E. (1992). *Storm Water Management Model, Version 4: user's manual*. USEPA report no. EPA 600/3-88/001a (NTIS PB 88-236641/AS) Athens Georgia.
- Ippish, O., Vogel, H.J. and Bastian, P. (2006). *Validity limits for Van Genuchten - Mualem model and implications for parameter estimation and numerical simulation*. Adv. Water Resour., 29(12), 1780-1789.
- Mentens, J., Raes, D. and Hermy, M. (2006). *Green roofs as a tool for solving the rainwater runoff problem in the urbanized 21st century?* Landsc. Urban Plan., 77(3), 217-226.
- Monterusso, M.A., Rowe, D.B., Rugh, C.L. and Russell, D.K. (2004). *Runoff water quantity and quality from green roof systems*. Acta Hort, 639, 369-376.
- Mualem, Y. (1976). *A new model to predicting the hydraulic conductivity of unsaturated porous media*. Water Resour. Res., 12(3), 513-522.

- Nash J.E. and Sutcliffe J.V. (1970). *River flow forecasting through conceptual models part I — A discussion of principles*. J. Hydrol., 10(3), 282-290.
- Palla A. (2009). *Unsaturated flow in engineered porous media for hydrologic restoration*. PhD thesis. Dept. of Civil, Environmental and Architectural Engineering, University of Genoa, Italy, 156 pp.
- Palla A., Gnecco, I. and Lanza, L.G. (2009). *Unsaturated 2-D modelling of subsurface water flow in the coarse-grained porous matrix of a green roof*. J. Hydrol., 379(1-2), 193-204.
- Šimůnek, J., Vogel, T. and Van Genuchten, M.Th. (1994). *The SWMS_2D code for simulating water flow and solute transport in two-dimensional variably saturated media, Version 1.21*. Research Report No. 132, U.S. Salinity Laboratory, USDA, ARS, Riverside, California, 197 pp.
- Topp, G.C., Davis, J.L. and Annan, A.P. (1980). *Electromagnetic determination of soil water content: measurement in coaxial transmission lines*. Water Resour. Res., 16(3), 574-582.
- Van Genuchten, M.Th. (1980). *A closed-form equation for predicting the hydraulic conductivity of unsaturated soils*. Soil Sci. Soc. Am. J., 44, 892-898.
- VanWoert, N.D., Rowe, D.B., Andresen, J.A., Rugh, C.L., Fernandez, R.T. and Xiao L. (2005). *Green Roof Storm water Retention: Effects of Roof Surface, Slope and Media Depth*. J. Environ. Qual., 34(3), 1036-1044.
- Villarreal, E.L., Semadeni-Davies, A. and Bengtsson, L. (2004). *Inner city stormwater control using a combination of best management practices*. Ecol. Eng., 22 (4-5), 279-298.