

Cost effectiveness of centralised and decentralised storm water treatment

Rentabilité de la gestion centralisée et décentralisée des eaux pluviales

Helmut Gruening, Holger Hoppe, Sven Messmann and Andreas Giga

Dr. Pecher AG, Klinkerweg 5, D-40699 Erkrath, Germany
(holger.hoppe@pecher.de)

RÉSUMÉ

Dans le cadre d'un projet R&D commandité par le Ministère de l'Environnement et de la Protection Naturelle, de l'Agriculture et de la Protection des Consommateurs (MUNLV) de la Région Rhénanie du Nord-Westphalie, les possibilités de rejet dans des eaux de réception (canalisées) des ruissellements d'eaux pluviales après traitement centralisé et décentralisé sont évaluées ensemble avec les coûts induits. Les évaluations concernent les différentes options en conditions réelles, avec utilisation des bassins Briller (Wuppertal – RFA) et Müggen (Remscheid – RFA) comme modèles. Les études portent sur une comparaison entre les traitements «décentralisé, semi-centralisé, centralisé» des eaux pluviales, le traitement centralisé des eaux pluviales impliquant un réseau d'assainissement séparé et un contrôle spécifique des ruissellements d'eaux pluviales en fonction de la pollution. Dans le cadre du projet de recherche, chacune des variantes sera développée et les coûts calculés afin de permettre une comparaison entre les différents systèmes. Les études porteront en particulier sur les exigences auxquelles les systèmes de drainage des eaux pluviales impliquant des systèmes d'assainissement séparatifs doivent répondre.

MOTS CLÉS

Rapport coût-efficacité, traitement décentralisé, systèmes d'assainissement séparatifs, traitement des eaux pluviales/d'orage

ABSTRACT

As part of a research & development project commissioned by the Land of North Rhine-Westphalia's Ministry for the Environment and Nature Conservation, Agriculture and Consumer Protection (MUNLV), the possibilities for global centralised and decentralised treatment storm water runoff to be discharged into (canalised) receiving waters are being assessed together with the ensuing costs. The different options are being assessed in real conditions, with the Briller Creek (Wuppertal/Germany) and Müggen Creek (Remscheid/Germany) catchment areas being used as models. The range of investigations deals with a comparison between "decentralised, semicentralised, centralised" storm water treatment, centralised storm water treatment involving a separate sewer and parameter-specific pollution based storm water runoff control. In the framework of the research project each of the variants is to be elaborated and the costs are to be calculated so as to permit a comparison between the different system designs. In particular, the investigations are to take into account the actual requirements to be met by storm water drainage systems involving separate sewage systems.

KEYWORDS

Cost effectiveness, decentralised treatment, separate sewage systems, storm water treatment

1 INTRODUCTION

Until a few decades ago, the dynamics of urban development involving intensive land use eclipsed the existence of natural watercourses. It was expedient for urbanisation areas to extend along the courses of rivers. At the time, the creeks that naturally discharged into the rivers were usually simply in the way of the town planners or just came in useful for discharging surface runoff. The creeks became part of the drainage system, either being straightened and forced into ground slabs or canalised in underground pipelines without any further ado. These “cased” streams and creeks often still have the legal status of watercourses and in some cases also have a substantial natural basic flow. In other cases, on the other hand, the natural source has been hidden by buildings and the inflow issuing from it is no longer identifiable. In addition to their natural basic flow, in some cases these virtual watercourses discharge considerable quantities of storm water runoff. In North Rhine-Westphalia, discharges are assessed according to pollution-specific criteria involving a utilisation-dependent classification of the surface concerned, and leading to stipulation of the necessity for centralised or decentralised treatment.

As part of a research & development project commissioned by the Land of North Rhine-Westphalia's Ministry for the Environment and Nature Conservation, Agriculture and Consumer Protection (MUNLV) an examination is being carried out of the general possibilities for treating storm water runoff to be discharged into (canalised) receiving waters and the costs ensuing from this. The examination of the different options is being carried out under real conditions, with the Briller Creek (Wuppertal) and Müggen Creek (Remscheid) catchment areas being used as models. The organisations executing this task are Dr. Pecher AG (Erkrath), the Reinhard Beck engineering consultants (Wuppertal), the City of Wuppertal, WSW Energie & Wasser AG, and the Remscheider Entsorgungsbetriebe waste disposal agency. The present paper contains a description of the investigations, taking the Briller Creek as an example.

2 METHODS

2.1 Comparison of decentralised, semicentralised and centralised storm water treatment

The range of investigations deals with a comparison between the following solutions:

- Decentralised storm water treatment
- Combination of “decentralised and semicentralised/centralised storm water treatment”
- Centralised storm water treatment in a sedimentation tank involving a separate sewer
- Parameter-specific pollution based storm water runoff control

The design of each of the variants is to be elaborated and the costs are to be calculated so as to permit a comparison between the different system designs. At the same time, the aim of the project is not to establish which of the options is the most cost-effective, but to compare the different options in an objective fashion.

In particular, the investigations are to take into account the actual requirements to be met by storm water drainage systems involving separate sewage systems (as described in Gruening and Hoppe, 2007). These requirements call for the preferred use of decentralised storm water treatment facilities so as to largely prevent storm water requiring treatment (e. g. motorways) from being mixed with “non-treatable” storm water (e. g. areas without traffic).

2.2 Test catchment area under examination and boundary conditions

Canalised streams belonging to the urban drainage system often feature a multiplicity of different discharge inlets, e.g.:

- Street gullies
- Connections to the storm water sewer system
- Estate drainage systems (private and public)
- Side discharge inlets for (paved and unpaved) catchment inflows

The Wuppertal Briller Creek system that was examined under the above-mentioned research project exhibits the characteristics presented in Table 1. According to these, more than two thirds of this creek extending over 7.5 km are canalised. The non-canalised (natural – open-air) sections of the stream are mainly restricted to the areas near the sources of the tributaries running into the stream. The runoff from 29.1 ha of the roughly 120 ha of surfaced areas connected up to the canalised creek requires treatment. These individual areas with runoff requiring treatment range from a few m² to about 3.5 ha in size.

Length of the watercourse system	7,478 m
of which: non-canalised (natural – open air) sections	2,380 m
of which: canalised sections	5,098 m
Tributaries feeding in water (part of the overall system)	5
Catchment area	383 ha
of which: paved surfaced areas connected up to the system	120 ha
of which: fraction of the area with storm water runoff requiring treatment	29.1 ha

Table 1: Characteristics of the partially-canalised system of the Wuppertal Briller Creek area

Table 2 provides an overview of all discharge inlets into the Briller Creek system, approx 7.5 km in length. Street gullies account for the bulk of all the discharge inlets. However, it is not always possible to exactly match up the respective discharge inlets, which were established from the sewer status investigation by recording the number of connecting nozzles. 31 of the 522 discharge inlets are located in natural sections of the stream, while 491 lead into the canalised stream. Accordingly, there are 70 discharge inlets on average over a length of 1 km. 128 of these discharge inlets are connected up to surfaces with storm water runoff requiring treatment.

Connection up of subcatchment areas by means of (municipal) storm sewers	40
of which into natural open-air sections	11
of which into canalised sections	29
Direct connection of privately-owned areas and street gullies	482
of which into natural open-air sections	20
of which into canalised sections	462
Total number of connections/discharge inlets	522
Discharge inlets serving areas with runoff requiring treatment	128

Table 2: Storm water discharge inlets into the partially-canalised Briller Creek

3 COMPARISON BETWEEN DIFFERENT TREATMENT CONCEPTS

3.1 General treatment options and locality-specific storm water treatment systems

The storm water treatment processes or systems currently used can be roughly divided up into three categories:

- **Sedimentation systems** (e.g. storm water overflow tanks, storm water sedimentation tanks, separators) – conventional systems which currently make up by far the majority of the systems used.
- **Filter systems** (mechanical filters or retention basins with soil filters) – here, retention basins with soil filters consist of a preliminary sedimentation stage and a filter system installed downstream.
- **Compact (decentralised) systems** – these are currently offered by various manufacturers which, however, currently lack long-term experience of the effects and mode of operation of the systems.

As a matter of principle, storm water can be treated by decentralised, semicentralised or centralised systems. Here, the terms do not primarily describe the type of treatment or the treatment process, but the positioning of the “tank or device” in the drainage system.

Decentralised treatment: Treatment of the runoff directly at the spot where the runoff is obtained. In this case, treatment is often carried out on privately-owned land. A classical example of this is the treatment of car-park runoff in shaft-type (filters) or gutter systems. These systems prevent runoff requiring treatment from being mixed with non-treatable runoff.

Semicentralised treatment: The runoff from a subsystem is purified in the treatment system. Here, for instance, runoff requiring treatment from rooftops and road surfaces can be collected and channelled into the treatment system. The objective here is to avoid mixing polluted with unpolluted discharges.

Centralised treatment: The runoff is treated just before being discharged into the receiving water. In this case, the whole of the interconnected sewage system is connected up so that the mixing together of runoff streams with various degrees of pollution is unavoidable. Finally, most storm water sedimentation tanks or storm water treatment in the WWTP constitutes a centralised type of treatment.

3.2 Boundary conditions and other concepts

The following specific questions pose themselves when a storm water treatment facility is being planned in a catchment area comprising canalised streams.

- On their own, the number of street feeding direct into a creek or stream in the vicinity of the street can make for a large number of inlets. Does that mean that an application for permission under water law has to be made for each of these discharge points?
- According to what criteria is treatment of storm water runoff to be laid down?
- What storm water treatment options are possible at all in cramped urban areas?
- Must treatment always be carried out upstream of the inlet into a canalised stream?

As well as considering storm water treatment options in general, an examination of alternatives in the course of the research project also covers:

- The construction of a new separate sewer to permit the separate discharge of storm water runoff with different degrees of pollution.
- An examination of the option of splitting up the storm water discharges depending on the degree of pollution based on continuous pollution monitoring by means of a photometric probe.

These various options will now be described in the following sections.

3.3 Variant 1: decentralised treatment

3.3.1 Taking into account the systems currently available

Decentralised systems can be basically divided up into three categories:

- Street gully inserts
- Gutter systems
- Shaft systems

Most of these products or systems that are available contain filter units designed to ensure treatment that is as thorough as possible or to ensure the maximum possible retention of substances (Dierkes et al., 2008). Various suppliers now provide systems with a variety of specifications. Thus, there are systems specially designed for the treatment of runoff from metal roofs or, as in the case of street gully inserts, due to the type of system involved, runoff is treated in traffic areas.

Compact (decentralised) processes of more recent origin are primarily suited for local use in the immediate vicinity of points at which runoff requiring treatment is obtained. But, in the case of some systems, semicentralised or centralised applications will be possible too. In the case of relatively small catchments (surfaced catchment areas covering up to roughly 1-2 ha), single, compact treatment systems installed upstream of the inlet to the receiving creek can take in and treat the whole of the runoff requiring treatment (Gruening and Giga, 2009).

3.3.2 Specifications for Variant 1

In the “decentralised treatment” option, the whole of the runoff requiring treatment is treated by decentralised means using compact treatment systems. That means that the storm sewer or the canalised stream only carries the natural basic flow and the runoff not requiring treatment.

The investigations provide for the preferable use of filter shaft-type systems. With regard to the FilitaPex® system (Dr. Pecher AG/WSW AG) that is usually taken as a model, relatively reliable data on maintenance and the effects of the system are already available (Figure 1). Proof of the system’s hydraulic capacity and substance retention properties is to be furnished by an examination project to be carried out at the same time as the main project (Gruening and Hoppe, 2007, 2008). Furthermore, the filter shaft system is already installed in the area under investigation.

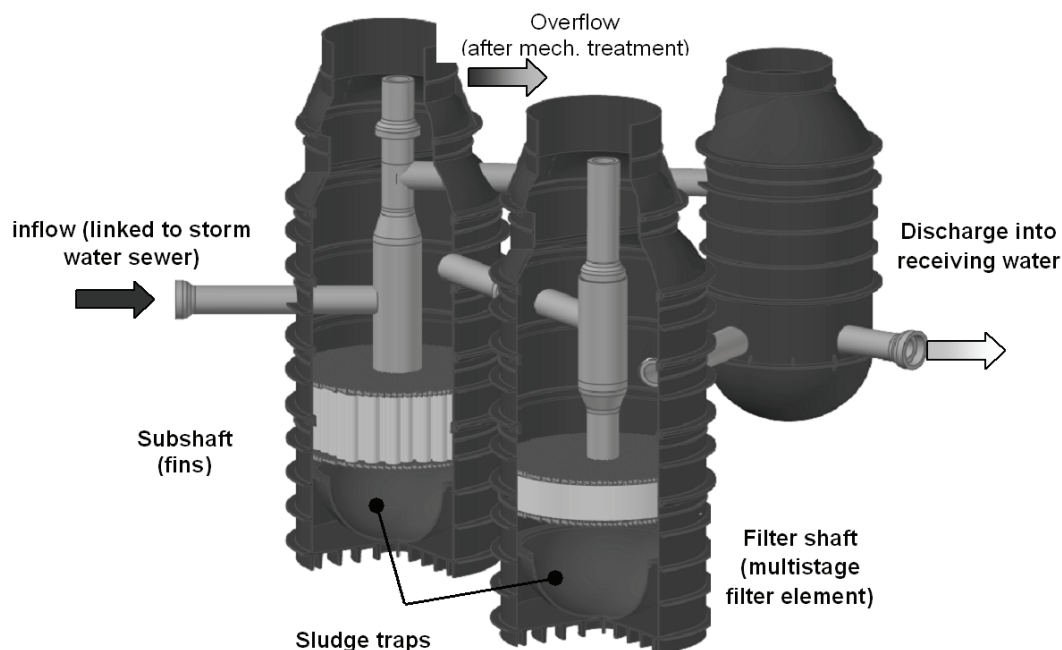

Figure 1: Decentralised storm water treatment option – presentation of the FilitaPex® system (Dr. Pecher AG/WSW AG) as a model

The treatment of street runoff is particularly difficult. Street gully inserts constitute a solution that permits storm water treatment at relatively little expense and effort. This solution entails retrofitting the existing street gullies with filter inserts. In the case of alternative facilities such as filter shafts, the system's extended longitudinal geometry would necessitate the clustering of street gullies; it is, however, the case that areas of several thousand m² can be connected up to many a shaft system.

So far, street gully inserts are still characterised by disadvantages that do not allow their unrestricted utilisation. The system assemblies in the existing gullies affect their discharge properties and consequently increase the danger of flooding. The entrainment of large-sized substances and solids (leaves, pollen) poses a special challenge. The existing systems cannot yet furnish proof of their ability to meet the long-term hydraulic requirements.

Due to the peculiarities of the system, street gully inserts have a limited hydraulic treatment capacity. In North Rhine-Westphalia treatment of 15 l/(s·ha) is necessary. On average, the system manufacturers specify an area of 400 m² per gully, so that 0.6 l/s would have to be treated on a permanent basis. Proof of an appropriate treatment capacity has yet to be furnished.

In the Briller Creek catchment area, runoff is discharged into the sewage system/receiving water through 1,238 ground surface gullies. 1,046 of these are street gullies and 192 are gullies on car-parks and in other areas. The inflows into 508 of these street gullies require treatment. The areas calculated to be connected up fluctuate between 213 and 1,336 m². If street gully inserts were to be installed over the whole of the catchment area, additional street gullies would have to be installed at various points. Within the scope of the investigations, street gully inserts are to be provided for in individual street sections.

3.4 Variant 2: Decentralised and semicentralised/centralised treatment as a combination-type solution

The "decentralised and semicentralised/centralised treatment" option provides preferably for storm water treatment cluster facilities for subcatchment areas. Treatment would be provided primarily by storm water sedimentation tanks. If possible, in this system the mixing of runoff requiring treatment with non-treatable runoff would be avoided. This would thus keep the receiving water free of inflows requiring treatment. This option also provides for street gully inserts for the treatment of runoff in individual street sections. The costs of the storm water treatment and retention tank include extra sums required for the construction of the feeder and discharge sewers.

3.5 Variant 3: Centralised treatment involving a separate sewer

The centralised treatment system examined under Variant 3 provides for a storm water sedimentation tank upstream of the discharge point into the Wupper, at the end of the catchment area. A storm water sedimentation tank with a considerable tank volume would be necessary. This "classical" solution requires discharge of the stream's natural basic flow separately from the runoff requiring treatment. As a result, the construction of a separate new sewer would be necessary. On the other hand, the integration of a diversion tunnel into the existing conducting drain ("pipe in pipe system") would be conceivable provided the system's hydraulic efficiency were to be assured. The runoff not requiring treatment (Category I) could then be discharged into the canalised stream. The design would have to take into account a runoff portion of 5 l/(s·ha) in the storm water treatment system from areas with runoff not requiring treatment.

The density of development in the area under examination is so great that the only solution to be taken into account is a closed concrete basin with a high specific cost exceeding € 3,000/m³. The separate sewer that would additionally be necessary in the vicinity of a road carrying a great deal of traffic would also entail specific costs of approx. € 800/m up to € 2,000/m (DN 150 to DN 1200, slope 0,2 % to 20 % – depth 1 m to 8 m).

3.6 Variant 4: Parameter-specific runoff control

3.6.1 Specifications for Variant 4

Variant 4 constitutes the solution already implemented in the Briller Creek catchment area. It entails a bifurcation of flow in a diversion structure upstream of the discharge point into the Wupper (Figure 2). The degree of pollution can be recorded continuously by means of a photometric probe installed in the creek (Gruber et al., 2006, Hoppe et al., 2009; Lacour et al., 2009). If the limit value fixed as an

indicating parameter is exceeded, the wastewater is diverted into the wastewater treatment plant (WWTP). The indicating parameter is provided by the particulates which, via the total suspended solids (TSS) concentration, a turbidity equivalent, are indirectly measurable by photometric means. If unpolluted stream water and, possibly, runoff not requiring treatment is running through the system, the hydraulic valve to the sewage system remains closed. If the solids concentration exceeds a limit value that can be set individually on a catchment-specific basis, the valve is opened to divert the portion of runoff that is polluted into the WWTP. Here, the limit value for TSS can be fixed individually depending on area utilisation and immission-specific conditions.

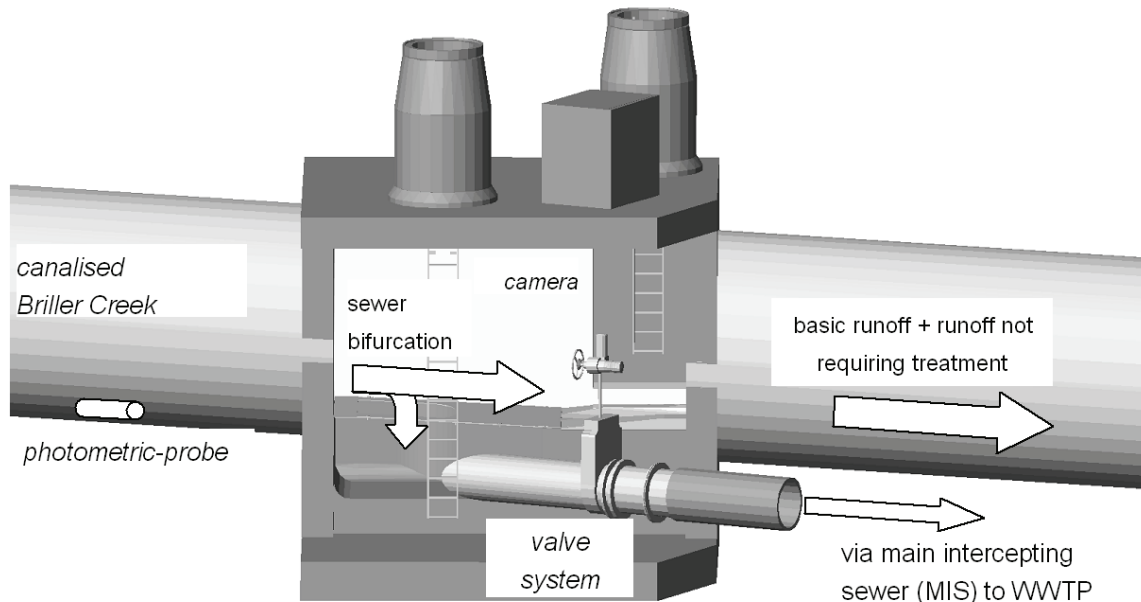

Figure 2: Flow bifurcation system as used in the diversion structures installed in Wuppertal's canalised streams (Hoppe et al., 2009)

As a result of the catchment-specific treatment requirement applicable to the separate system, the mixing of runoff with different degrees of pollution that occurs here becomes a general feature of the system. If no decentralised or semicentralised treatment is performed, centralised treatment plants take in additional quantities of unpolluted runoff, and the latter are then to be taken into account via appropriate design factors (e.g. increasing treatment volume).

3.6.2 System parameters

The existing diversion structure designed for separating off the portion of runoff that requires treatment is located below a main traffic junction. The portion of runoff that requires treatment amounts to roughly $1 \text{ m}^3/\text{s}$. The limit value for the solids equivalent reading is currently 100 mg/l (Hoppe et al., 2009). This value can be adapted to the circumstances at any time. Currently, the - in hydraulic terms - maximum possible discharge into the sewage treatment plant occurs if the threshold concentration is exceeded. This discharge is considerably higher than the portion of runoff requiring treatment, which amounts to $15 \text{ l}/(\text{s}\cdot\text{ha})$ or more than $1 \text{ m}^3/\text{s}$.

In addition to the cost of RTC equipment, the cost of building the flow bifurcation structure (the diversion structure) accounts for the bulk of the capital expenditure. The capital cost is around € 1.8 million. Here, the cost of the photometric probe – up to € 30,000 – only represents a marginal portion. The necessary operating expenditure will only be definitively ascertainable in the future, after a fairly long operating period. Currently, system maintenance at two-monthly intervals is being assumed, given continuous remote data transmission and constant video monitoring from a control room so as to ensure continuous surveillance.

To date, however, the operation of such probe-dependent runoff control systems still requires a great deal of experience and close operational monitoring of the measurement setup.

4 COMPARISON BETWEEN CENTRALISED AND DECENTRALISED SCHEMES

The cost of the various processes will be definitively established in the course of the project by the end of 2009. The reliable ascertainment of the regular costs in particular entails special effort and expense. As far as that is concerned, the costs stated below are to be viewed as being “provisional”.

To date, the ascertainment both of the capital cost and of the regular costs of decentralised systems is still beset with considerable uncertainty. In the scope of the investigations there are no plans for opting in general for a certain product that would permit decentralised storm water treatment. Consequently, the costs are not being determined from a “system-specific” angle but on the basis of the average price estimates for filter systems. In this respect, experience of the FiltaPex® filter shaft system that is already installed in the area under investigation is being taken into account primarily. For this system, the following average costs per site are applicable:

- System costs: € 10,000-20,000
- Construction costs: € 10,000-50,000
- Regular (operating) costs: € 2,000-3,000 per year

The dynamic production costs (prime costs), here ascertained in the form of the specific annual costs per m² of area connected up and producing runoff requiring treatment, are in the region of

roughly € 1/(m² per year).

Here, the estimate is based on a connected up surfaced area of 5,000 m², and entails a simple system arrangement (subshaft plus one filter shaft). The regular operating costs include a monthly system check and emptying of the sludge collection chambers at six-monthly intervals. Replacement of the filter material is provided for once a year.

Leisse (2008) determined the area-specific costs of various decentralised treatment systems to be between € 0.40 and € 60 per m². These figures cover the pure system costs – not counting the construction and operating costs.

Decentralised systems with an adequate standard of quality are not cheap products. A cost advantage of decentralised systems makes itself felt in cases in which, in areas with a high density of development, small, isolated catchments lead into discharge streams requiring treatment. Due to their being directly integrated into the existing storm water drainage system these systems require hardly any space. Since, by their very nature, efficient filter systems retain a large percentage of substances, correspondingly high maintenance costs are unavoidable and necessary. For most sewage system operators, considering the normal levels of equipment and staffing, the distribution of a large number of decentralised systems over a wide area will currently not be controllable.

It is not possible to make a general cost comparison between decentralised systems and storm water sedimentation tanks. The minimum size of 50 m³ that previously applied to the construction of storm water sedimentation tanks in North Rhine-Westphalia no longer applies. However, a storm water sedimentation tank is unlikely to be installed for the treatment of undivided areas covering less than a few 1,000 m².

Due to the boundary conditions, the specific construction costs of a storm water sedimentation tank are above € 3,000 per m³. Due to their limited treatment effects, storm water sedimentation tanks are to be viewed critically. The operating costs of storm water sedimentation tanks fluctuate greatly. In addition to cleaning, which has to be carried out once or twice a year, maintenance measures are also required; these are laid down as a matter of principle by the “Selbstüberwachungsverordnung Kanal” (self-monitoring regulations for sewers). In addition to evaluation of the measured values, the latter include regular serviceability checks at monthly intervals.

When comparing the two systems from a cost-specific angle, it is necessary to observe the following criteria:

- Filter systems have a considerably higher purification efficiency than classical sedimentation basins.
- Small-volume storm water sedimentation tanks can possibly be constructed at low cost using products prefabricated by various manufacturers.

- Storm water sedimentation tanks need a connection to the sanitary sewage system.
- Storm water sedimentation tanks pose a problem if there is a constant influx of water (e.g. infiltrated water or connected creeks) that fills the retention tank with clean water.

When assessing the costs used as a basis here, it has to be taken into account that, with but few exceptions, the site conditions are associated with special requirements. The facility is to be installed in an inner-city area. This entails measures designed to safeguard traffic and the extra expense of breaking up and restoring the surfaces concerned.

5 CONCLUSIONS

When examining the various schemes, it is not establishing the cheapest option but an objective comparison between the various alternatives that has been intentionally posited as the project goal. Taking development-specific restrictions into account, some individual schemes are perhaps feasible more in theory than in practice, but they are basically feasible in engineering terms. The provisional results of the investigation permit the following conclusions to be drawn:

- The installation of decentralised storm water treatment systems over large areas is not cheap. As regards all the processes, no operating permits have as yet been issued on the basis of a comparison with conventional systems in terms of effects and operating behaviour as laid down by the State of North Rhine-Westphalia decree regulating the treatment of combined sewage. The large number of operating points that would be necessary in the catchment area under examination would not be controllable for sewage system operators.
- The installation of a separate sewer with a storm water sedimentation tank upstream of the receiving water and right in the heart of the city would require elaborate and expensive underground construction measures. There is simply no room for the storm water sedimentation tank. Adverse effects on traffic in the vicinity of the area and main thoroughfares are hardly justifiable and would lead to serious political and logistic problems.
- A combination-type solution involving individual systems and systems distributed over a wider area would also be difficult due to the cramped conditions. The additional construction work would also be expensive on account of the cost of the feeder and discharge channels.
- Variant 4 – a parameter-specific runoff control system – has already been implemented and is now being operated successfully. Here, experience is being successively accumulated with a view to assuring a permanently stable operating status. Within the scope of the overall control concept covering all the storm water treatment tanks in the catchment area of the WWTP and the main river itself, this control system is to be examined at greater depth and optimised. It is here especially that the system's particular advantage is to be found: its flexibility.

LIST OF REFERENCES

- Dierkes, C., Schumann, A. and Hyett G. (2008). Performance of an innovative treatment device for runoff from roads with high traffic densities.- Proceedings ICUD, Edinburgh, Scotland
- Gruber, G., Bertrand-Krajewski, J.-L., De Beneditis, J., Hochedlinger, M. and Lettl, W. (2006). *Practical aspects, experiences and strategies by using UV/VIS sensors for long-term sewer monitoring*. Water Practice & Technology, 1(1), 1-8.
- Gruening, H. and Hoppe, H. (2007). *Innovative alternatives for the treatment of stormwater in separate sewage system catchments*. NOVATECH 2007 6th international conference on sustainable techniques and strategies in urban water management. Lyon - France - June 25-28, 2007, Vol.2 , pp. 649-656.
- Gruening, H. and Hoppe, H. (2008). *Spectrophotometric applications in wastewater and storm water sewers*. 11th International Conference on Urban Drainage IWA-ICUD, Edinburgh, Scotland, UK, 2008
- Gruening, H. and Giga, A. (2009) *Möglichkeiten und Grenzen der dezentralen Regenwasserbehandlung: Straßeneinläufe – Rinnen – Schächte*. BEW Seminar on "Regenrückhaltebecken und Retentionsbodenfilter", on 23 June 2009, Essen / Germany
- Hoppe, H., Messmann, S., Giga, A. and Gruening, H. (2009). *A real-time control strategy for separation of highly polluted storm water based on UV-Vis online measurements – from theory to operation*. NOVATECH 2010 7th international conference on sustainable techniques and strategies in urban water management. Lyon – France (submitted).
- Lacour, C., Joannis, C., Gromaire, M.-C., and Chebbo, G. (2009). Potential of turbidity monitoring for real time control of pollutant discharge in sewers during rainfall events. Water Science & Technology, 59(8), 1471-1478.
- Leisse, R. (2008) *Anlagen zur dezentralen Behandlung von Niederschlagswasser im Trennverfahren*. Diploma thesis. Fachhochschule Köln (Cologne technological university)