

Distributed high-temperature optical fiber sensor based on a Brillouin optical time domain analyzer and multimode gold-coated fiber

Ruben Ruiz-Lombera, Ismail Laarossi, Luis Rodriguez-Cobo, Maria Angeles Quintela, Jose-Miguel Lopez-Higuera *Senior Member, IEEE* and Jesus Mirapeix

Abstract—A high-temperature distributed sensor system based on a Brillouin optical time domain analyzer and a multimode gold-coated fiber is presented in this paper. Distributed measurements of temperatures up to 600°C are demonstrated with a temperature accuracy of about 10°C . The system shows a consistent response for repetitive measurements, even considering increasing or decreasing temperature changes. This is the first time to our knowledge that a gold-coated fiber is used for high-temperature distributed measurements in a Brillouin-based system. The proposed solution via the gold-coated fiber allows a feasible deployment in field applications such as industrial scenarios.

Index Terms—Stimulated Brillouin scattering, distributed systems, optical fiber sensors, gold-coated fiber, high-temperature measurements

I. INTRODUCTION

Optical fiber distributed sensor systems have been an intense area of research in the last years due to their unique features to provide strain and temperature distributed measurements over tens of kilometers with meter spatial resolutions and exhibiting immunity to electromagnetic interference and harsh and highly radiative environments [1]. Since the first proposal to measure distributed temperature using the nonlinear Brillouin effect [2], Brillouin optical time domain analyzers (BOTDAs) have been extensively used for over two and a half decades [3]. It is based on the stimulated Brillouin scattering (SBS), where two counter-propagating waves, the so-called pump and probe waves, interact within the optical fiber via acoustic phonons [4]. The spatial information where the interaction takes place can be retrieved provided that the pump wave is pulsed, with the pulse duration defining the achieved spatial resolution. For standard long-range BOTDA implementations, the spatial resolution is limited to 1m (10 ns pulse) due to the limitation imposed by the phonon lifetime [4]. Alternative proposals,

such as the differential pulse pair (DPP) technique [5], pre-pumping [6] or dark pulses [7] allow to reach improved sub-meter spatial resolutions.

Among the diverse applications of these systems, e.g. structural health monitoring [8], there are several based on the estimation of temperature along the fiber cable. Solutions for the detection of fires [9], leakages in large oil, gas or water infrastructures [10], [11] or failures in power cables [12] have been proposed. Raman-based distributed systems have also been employed as distributed temperature sensors (DTSS). Among other differences, they are based on intensity-detection schemes in comparison to the frequency detection implemented in SBS approaches, higher optical powers are required to allow a suitable performance and they are not affected by strain-induced errors. High-temperature distributed sensing (above 300°C), required for applications such as the monitoring of oil wells or industrial sectors like the manufacturing of heavy components for nuclear power stations, has been explored in Raman-based solutions [13]. Ge doped and pure silica core multimode optical fibers have been used for temperature measurements up to 600°C [14]. High-temperature distributed sensing via BOTDAs has also been recently demonstrated by Wang et al. using a BOTDA system to measure temperatures up to 1000°C , with 5m spatial resolution, although the optical fiber employed in this work was not specified [15]. Dong et al. have presented 1100 and 1200°C distributed measurements with a BOTDA configuration using single mode fiber (SMF) and a pure-silica photonics crystal fiber (PCF) and measurement accuracies of ± 2 and $\pm 4^{\circ}\text{C}$, respectively [16].

The deployment of these distributed system in real field scenarios will imply the necessity of considering special coated fibers able to resist harsh environments. For temperatures under 300°C , polyimide-coated fibers can be considered, but higher temperatures will require the employment of other solutions, such as metal coatings like aluminium or gold [17]. The manufacturing of these special coated fibers can be performed after drawing in a separate process (off-line) or during drawing (in-line). The so-called freezing method is applied when the latter option is chosen. In this case, the fiber is passed through a layer of approximately few millimeters of molten metal. Provided that the melt exhibits a temperature close to the melting point of the metal and that the temperature of the fiber is somewhat lower, a layer of metal can freeze on the surface of the fiber. The duration

Manuscript received XXXXXX XX, XXXX; revised XXXXXX XX, XXXX; accepted XXXXXX XX, XXXX. Date of publication XXXXXX XX, XXXX; date of current version XXXXXX XX, XXXX

R. Ruiz-Lombera and I. Laarossi are with the Photonics Engineering Group of Universidad de Cantabria, 39005, Santander, Spain. (e-mail: ruben.ruiz@unican.es; ismail.laarossi@unican.es)

L. Rodriguez-Cobo, M.A. Quintela, J.M. Lopez-Higuera and J. Mirapeix are with the Photonics Engineering Group of Universidad de Cantabria, 39005, Santander, Spain, and also with the CIBER-bbn, Instituto de Salud Carlos III, 28029, Madrid, Spain. (e-mail: luis.rodriguez@unican.es; angeles.quintela@unican.es; miguel.lopezhiguera@unican.es; jesus.mirapeix@unican.es)

Color versions of one or more of the figures in this paper are available online at <http://ieeexplore.ieee.org>.

of the contact of the fiber with the molten metal should be shorter than the time of the fiber heating to the metal melting point. If this condition is not fulfilled, the frozen layer will melt again and the fiber will exit the metallizer without any coating [18]. These metal coated fibers allow high-temperature measurements, but they exhibit high attenuation, especially at low temperatures, due to both hydrogen ingress and microbending losses due to thermal stress [17]. This may be a problem for Raman-based systems where the measurement of temperature is based on the detection of the intensity of the scattered signals, due to the considerably attenuation decrease for higher temperatures, which can give rise to errors in the measurements. However, distributed systems based on the Brillouin scattering perform a frequency-based detection, thus being more suitable to scenarios where attenuation can be very dependent with temperature.

In this paper we present a high-temperature distributed system based on a BOTDA implementation and a gold-coated multimode optical fiber. In a previous work a gold-coated fiber was used to achieve centimeter spatial resolution over a 1 meter fiber using a system based on swept wavelength interferometry and Rayleigh scattering [19]. This is the first time to our knowledge that such fiber is used in a Brillouin-based distributed system for high-temperature sensing. In comparison to the fibers employed in previous works dealing with distributed high-temperature measurements via BOTDAs [15], [16], the fiber considered in this work is suitable for its deployment in real field scenarios and to survive to a wide range of temperatures (from -269 to 700°C) and to harsh environments due to the mechanical properties of the gold coated protection.

II. FUNDAMENTALS

Brillouin optical time domain analyzers are based on the stimulated Brillouin scattering generated via the interaction of the counter-propagating pump and probe waves. The frequency difference between both signals is important, as the maximum Brillouin gain will be achieved when they are separated ν_B , the Brillouin frequency of the fiber under analysis:

$$\nu_B = \frac{2n_{eff}V_a}{\lambda_p}, \quad (1)$$

where n_{eff} is the effective core refractive index, V_a the acoustic velocity and λ_p the wavelength of the pump wave in vacuum. To acquire the whole Brillouin Gain Spectrum (BGS) it is necessary to scan a certain frequency range by modifying the frequency difference between pump and probe waves. This is typically accomplished by sweeping the probe wave with a modulator driven by a RF generator. Provided that the BGS has been acquired, the Brillouin Frequency Shift (BFS) can be estimated via Lorentzian fitting.

The BFS exhibits a linear dependence on the local temperature variation Δ_T and the applied strain $\Delta\epsilon$ that for low temperatures that can be expressed as follows [20]:

$$\nu_B(T, \epsilon) = C_\epsilon\Delta\epsilon + C_T\Delta_T + \nu_B(T_0, \epsilon_0), \quad (2)$$

where C_ϵ and C_T are the strain ($MHz/\mu\epsilon$) and temperature ($MHz/^\circ\text{C}$) coefficients and T_0 and ϵ_0 the reference temperature and strain. These values are mainly determined by the fiber composition and external protections (coatings and jackets) [21].

Results provided by other authors suggest that the best fitting when dealing with high-temperature measurements may be accomplished by means of a negative exponential [16].

When monomode fibers are used as the sensing element, part of the energy of the higher frequency pump (if a gain configuration is considered) will be transferred to the chosen lower frequency probe sideband via the acoustic wave. The use of a multimode fiber enables the appearance of several optical and acoustic modes. This implies that the resulting BGS will be formed by the addition of the contributions of various pairs of counter-propagating optical modes interacting through a given acoustic mode [22]. Although this broaden and even non-symmetrical BGS may affect the final system accuracy, if a lateral offset in the splicings between the optical fiber transitions is avoided, the contribution of higher-order modes will be suppressed [23], thus favoring the system performance. The vast majority of BOTDA implementations reported in the literature has considered monomode fibers, given their superior features for long distance sensing. However, the study of the performance of multimode fibers may prove interesting, for example to achieve bend-insensitive solutions or to explore the possible use of the multiple mode interactions to enable the discrimination between strain and temperature measurements.

III. EXPERIMENTAL SETUP

The fiber under test (FUT) designed setup and employed in the experimental tests shown in Fig. 1 (a). It can be observed how the multimode gold-coated fiber is accessed via conventional silica graded-index multimode fiber and, additionally, two short sections of monomode fibers have also been spliced at both ends to allow a straightforward connection to the BOTDA system access ends. The gold-coated section (FiberGuide AFS50/125/155G) is formed by 78m, where the last 4m are placed within a furnace chamber. Longer lengths of this fiber might be employed in the proposed system, with the only limitation of the fiber attenuation (around 20dB/km). This high attenuation is mainly due to the microbendings generated by the metal coating. The gold fiber is a $50\mu\text{m}$ Pure Fused Silica Core and $125\mu\text{m}$ Fluorine Doped Silica Cladding. The optical losses are around 20dB/km.

Conventional BOTDA systems are typically implemented using monomode optical fibers as FUT, given mainly to their higher performance in terms of attenuation. There are few works where multimode fibers are used for distributed measurements based on SBS. Minardo et al. [22] carried out a numerical and experimental study with graded-index multimode fibers and Xu et al. [23] developed a bend-insensitive distributed BOTDA sensor using a graded-index multimode fiber as sensing fiber.

The experimental setup described in Figure 1(b) was employed to carry out the experimental tests. The BOTDA system is formed by a distributed feedback laser (DFB) source, whose

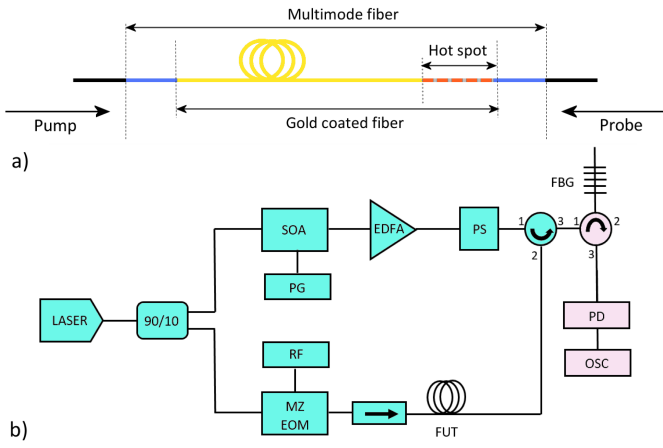

Fig. 1. (a) Fiber under test employed with standard monomode fiber on both sides (black), multimode graded index fiber (blue) and gold-coated fiber of 74m length (yellow) and 4m length (red dashed line); (b) Schematic setup of the BOTDA system used in the experimental tests: semiconductor optical amplifier (SOA), pulse generator (PG), erbium-doped fiber amplifier (EDFA), polarization scrambler (PS), Mach-Zender electro-optical modulator (MZ-EOM), RF Generator (RF), fiber under test (FUT), fiber Bragg grating (FBG), photodetector (PD) and oscilloscope (OSC)

output is divided by a 90/10 coupler into two branches. The upper branch generates the pulsed pump wave (10 ns) via a semiconductor optical amplifier (SOA) (connected to a pulse generator (PG)) providing an extinction ratio above 40 dB. An erbium-doped fiber amplifier (EDFA) is used to boost the pump pulse power and a polarization scrambler (PS) is used to avoid the polarization dependence of the SBS gain along the fiber. The probe wave is formed in the lower branch by an electro-optical modulator (EOM) driven by a RF generator, followed by an isolator and the FUT. The system works in a balanced configuration, i.e. both Stokes and anti-Stokes signals enter the FUT and participate in their corresponding SBS processes. At the output of the system, once the SBS interaction has taken place within the FUT, the resulting optical signal is filtered by a narrow fiber Bragg grating (FBG) and only the Stokes component is directed to a 125 MHz photodetector (PD) by an optical circulator, thus a gain configuration is considered. Finally, an oscilloscope is employed to acquire and perform a 1024 averaging of the BOTDA traces. In our system, a probe power of 8mW and a pump peak power of 2W are used to obtain an optimal signal at detection. It is worth noting that Raman distributed systems typically use pump powers of around tens of W, i.e. in a 40 km long Raman sensor a pump pulse of 10 ns and 20 W was employed [24].

IV. EXPERIMENTAL ISSUES

A set of experimental tests was carried out to study the ability of the designed system to perform distributed high-temperature measurements. A 4 meter section of the gold-coated fiber (at the end of the FUT) was placed within a furnace chamber and different temperatures between 50°C and 600°C were analyzed (with temperature steps of 50°C), with the temperature provided by the furnace thermocouple used

as reference. 4 measurements were performed at each temperature. Figure 2 presents these results, where the estimated BFS (after the Lorentzian fitting process) has been represented against the FUT distance. It can be clearly observed how the temperature differences give rise to different BFSs that are clearly distinguishable at the hot-spot section.

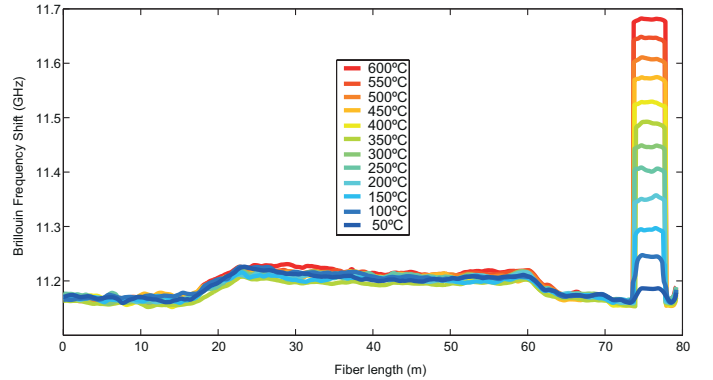

Fig. 2. Brillouin frequency shift vs. fiber length for temperatures at the hot-spot section from 50 to 600°C .

Figure 3 shows the same results previously discussed but considering descending temperatures from 600 to 50°C . This study is important to verify that a similar response is obtained and that the measurement system is free from hysteresis. Again, it can be validated how the temperature differences clearly appear at the hot-spot section with a behavior similar to the one presented in Figure 2.

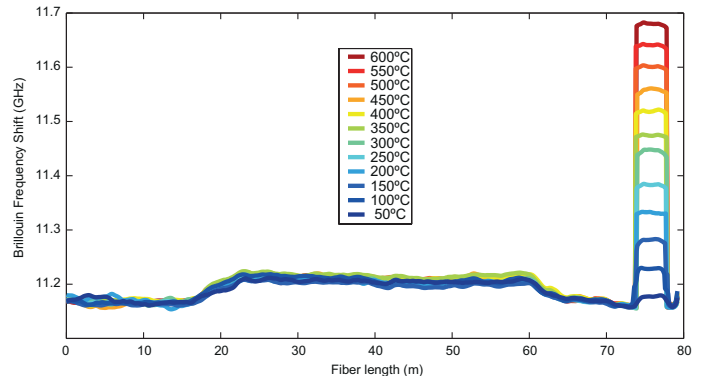

Fig. 3. Brillouin frequency shift vs. fiber length for temperatures at the hot-spot section from 600 to 50°C .

Figure 4 shows the resulting fitting of the BFS measured for each considered temperature at the hot-spot section of the FUT. 8 different measurements were carried out for each temperature. The blue markers in Figure 4 are associated with a cycle of increasing temperature from 50 to 600°C , while the green markers are associated with the corresponding decreasing cycle. These markers show the mean of the BFS at different temperatures for each spatial point at the hot-spot section when the temperature of the furnace is stable. It is also worth noting that there appears no temperature hopping [16] given that the considered temperatures are below 800°C . A fitting of these data gives rise to an exponential fitting expressed via the following expression:

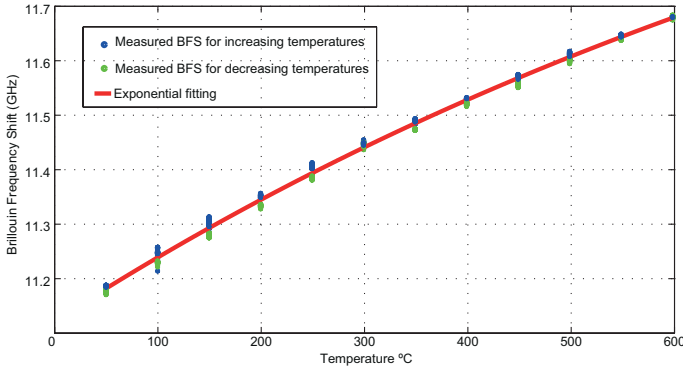

Fig. 4. Brillouin frequency shift vs. temperature at the hot-spot section. The red line shows the fitting of BFS for the temperature between 50 to 600°C. Blue/green markers show the measured BFS for the increasing/decreasing temperatures.

$$\nu_B = -1269e^{-0.0010T} + 12390 \quad (3)$$

where ν_B is the BFS expressed in MHz and T is the temperature in Celsius. Using this exponential curve the value of R^2 is 0.9976 and the mean error between the measured data and the real temperature is $\pm 7.7^\circ C$.

To validate the fitting equation obtained employing the previous data, additional temperature measurements have been carried out. Given that the process of changing and stabilizing the temperature of the furnace chamber is very slow, several measurements have been done for each temperature. In this case, a new cycle of increasing temperatures has been considered. The differences between the measured temperatures (applying Eq. 3 to the measured Brillouin frequency) and the temperatures provided by the furnace thermocouple are presented in Table I. The temperature error of Table I is calculated subtracting the average of the different measurements for each temperature and the reference temperature of the furnace.

TABLE I
AVERAGED BFS VALUES, ESTIMATED TEMPERATURE AND MEAN ERROR FOR EACH TEMPERATURE.

Reference Temperature (°C)	Measured BFS (GHz)	Measured Temperature (°C)	Temperature error (°C)
50	11.187	55.69	5.69
100	11.239	101.95	1.95
150	11.295	152.93	2.93
200	11.346	202.72	2.72
250	11.394	251.17	1.17
300	11.443	304.35	4.35
350	11.483	349.15	0.85
400	11.525	397.41	2.59
450	11.566	447.84	2.15
500	11.602	493.78	6.21
550	11.636	540.00	9.99
600	11.672	590.46	9.53

The analysis of the evolution of the BGS for each scenario has been represented in Figures 5 and 6 for increasing and decreasing temperatures. It can be appreciated that no significant distortions appear in the BGS as the temperature varies. In both cases, a constant gain appears at a fixed frequency (natural Brillouin frequency of the fiber) away from the one associated

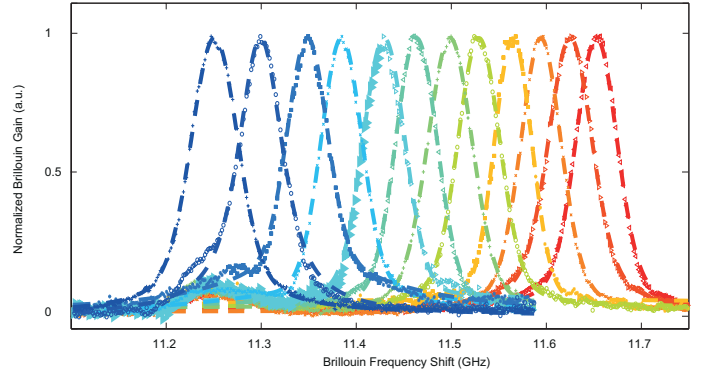

Fig. 5. Evolution of the BGS for increasing temperatures.

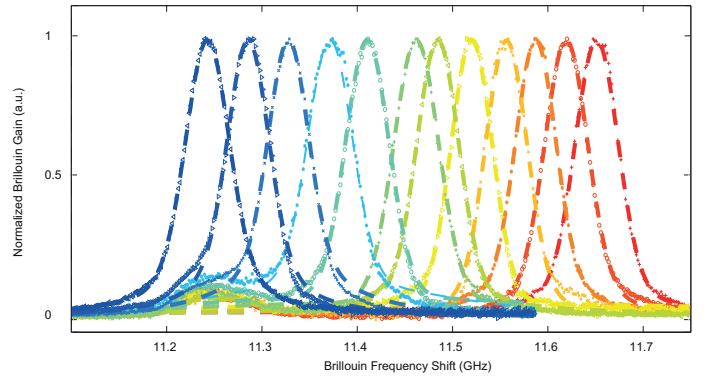

Fig. 6. Evolution of the BGS for decreasing temperatures.

with the measured temperature. This effect is provoked by the leakage signal generated during the pulse formation at the SOA due to the high pump power required.

V. CONCLUSIONS

In this work, a distributed high-temperature measurement system based on a Brillouin optical time domain analyzer and a multimode gold-coated fiber has been presented. This is the first time to our knowledge that a multimode gold-coated fiber has been used for high-temperature measurement in a SBS-based optical fiber distributed system. A few previous works have dealt with high-temperature sensing via BOTDAs [15], [16], but the gold-coated fiber ensures a feasible fiber deployment in field applications for temperatures up to 600°C. Experimental tests have been carried out demonstrating the feasibility of the proposed approach. The system response for both increasing and decreasing temperatures between 50 and 600°C has been obtained, showing a very similar behavior that can be modeled via exponential fitting. A good temperature mean accuracy of about 10°C has been estimated, showing a suitable system performance. High-temperature field tests in an industrial environment with the proposed solution are in process. Studies devoted to the minimization of the fiber attenuation and the maximum achievable measurement length with this kind of fiber in a BOTDA system will also be performed.

ACKNOWLEDGEMENTS

This work has been supported by the projects TEC2013-47264-C2-1-R and TEC2016-76021-C2-2-R of the Spanish government and by a Parliament of Cantabria postdoc grant.

REFERENCES

- [1] I. Toccafondo, T. Nannipieri, A. Signorini, E. Guillermain, J. Kuhnhen, M. Brugger, and F. Di Pasquale, "Raman distributed temperature sensing at cern," *Photonics Technology Letters, IEEE*, vol. 27, no. 20, pp. 2182–2185, 2015.
- [2] D. Culverhouse, F. Farahi, C. Pannell, and D. Jackson, "Potential of stimulated brillouin scattering as sensing mechanism for distributed temperature sensors," *Electronics Letters*, vol. 25, no. 14, pp. 913–915, 1989.
- [3] T. Horiguchi, T. Kurashima, and M. Tateda, "A technique to measure distributed strain in optical fibers," *Photonics Technology Letters, IEEE*, vol. 2, no. 5, pp. 352–354, 1990.
- [4] M. Nikles, L. Thevenaz, and P. Robert, "Brillouin gain spectrum characterization in single-mode optical fibers," *Lightwave Technology, Journal of*, vol. 15, no. 10, pp. 1842–1851, 1997.
- [5] W. Li, X. Bao, Y. Li, and L. Chen, "Differential pulse-width pair botda for high spatial resolution sensing," *Optics express*, vol. 16, no. 26, pp. 21 616–21 625, 2008.
- [6] K. Kishida and C. Li, "Pulse pre-pump-botda technology for new generation of distributed strain measuring system," *Structural health monitoring and intelligent infrastructure*, pp. 471–477, 2005.
- [7] A. W. Brown, B. G. Colpitts, and K. Brown, "Distributed sensor based on dark-pulse brillouin scattering," *Photonics Technology Letters, IEEE*, vol. 17, no. 7, pp. 1501–1503, 2005.
- [8] J. M. López-Higuera, L. Rodríguez Cobo, A. Q. Incera, and L. R. Cobo, "Fiber optic sensors in structural health monitoring," *Lightwave Technology, Journal of*, vol. 29, no. 4, pp. 587–608, 2011.
- [9] Z. Liu, G. Ferrier, X. Bao, X. Zeng, Q. Yu, and A. Kim, "Brillouin scattering based distributed fiber optic temperature sensing for fire detection," *Fire Safety Science*, vol. 7, pp. 221–232, 2003.
- [10] M. Nikls, B. H. Vogel, F. Briffod, S. Grosswig, F. Sausser, S. Luebbecke, A. Bals, and T. Pfeiffer, "Leakage detection using fiber optics distributed temperature monitoring," in *Smart Structures and Materials*. International Society for Optics and Photonics, Conference Proceedings, pp. 18–25.
- [11] R. Ruiz Lombera, J. Mirapeix Serrano, O. Martinez, J. D. San Emeterio, and J. M. Lopez-Higuera, "Experimental demonstration of a leakage monitoring system for large diameter water pipes using a fiber optic distributed sensor system," in *SENSORS, 2014 IEEE*. IEEE, Conference Proceedings, pp. 1885–1888.
- [12] G. Yilmaz and S. E. Karlik, "A distributed optical fiber sensor for temperature detection in power cables," *Sensors and Actuators A: Physical*, vol. 125, no. 2, pp. 148–155, 2006.
- [13] G. R. Williams, G. Brown, W. Hawthorne, A. H. Hartog, and P. C. Waite, "Distributed temperature sensing (dts) to characterize the performance of producing oil wells," in *Environmental and Industrial Sensing*. International Society for Optics and Photonics, 2000, pp. 39–54.
- [14] S. Mandal, S. Dekate, B. K. Lee, R. Guida, M. Mondanos, J. Yeo, and M. Goranson, "Characterization and calibration of raman based distributed temperature sensing system for 600 c operation," in *SPIE Sensing Technology+ Applications*. International Society for Optics and Photonics, Conference Proceedings, pp. 94 910A–94 910A–8.
- [15] J. Wang, D. Hu, D. Y. Wang, and A. Wang, "Fully-distributed fiber-optic high temperature sensing based on stimulated brillouin scattering," in *SPIE Defense, Security, and Sensing*. International Society for Optics and Photonics, Conference Proceedings, pp. 87 220E–87 220E–7.
- [16] Y. Dong, P. Xu, C. Fu, C. Zhang, D. Zhou, T. Jiang, H. Zhang, Z. Lu, L. Chen, and X. Bao, "1200 c high-temperature distributed brillouin optical fiber sensing based on photonics crystal fiber," in *International Conference on Optical Fibre Sensors (OFS24)*. International Society for Optics and Photonics, Conference Proceedings, pp. 963 485–963 485–4.
- [17] T. Reinsch and J. Hennings, "Temperature-dependent characterization of optical fibres for distributed temperature sensing in hot geothermal wells," *Measurement Science and Technology*, vol. 21, no. 9, p. 094022, 2010.
- [18] A. Mendez and T. Morse, *Specialty Optical Fibers Handbook*. Elsevier, 2006.
- [19] A. K. Sang, D. Gifford, B. Dickerson, B. Fielder, and M. Froggatt, "One centimeter spatial resolution temperature measurements in a nuclear reactor using rayleigh scatter in optical fiber," in *Third European Workshop on Optical Fibre Sensors*. International Society for Optics and Photonics, Conference Proceedings, pp. 66 193D–66 193D–4.
- [20] T. Horiguchi, K. Shimizu, T. Kurashima, M. Tateda, and Y. Koyamada, "Development of a distributed sensing technique using brillouin scattering: Optical fiber sensors," *Journal of lightwave technology*, vol. 13, no. 7, pp. 1296–1302, 1995.
- [21] C. A. Galindez-Jamioy and J. M. Lpez-Higuera, "Brillouin distributed fiber sensors: an overview and applications," *Journal of Sensors*, vol. 2012, 2012.
- [22] A. Minardo, R. Bernini, and L. Zeni, "Experimental and numerical study on stimulated brillouin scattering in a graded-index multimode fiber," *Optics express*, vol. 22, no. 14, pp. 17 480–17 489, 2014.
- [23] P. Xu, Y. Dong, J. Zhang, D. Zhou, T. Jiang, J. Xu, H. Zhang, T. Zhu, Z. Lu, and L. Chen, "Bend-insensitive distributed sensing in singlemode-multimode-singlemode optical fiber structure by using brillouin optical time-domain analysis," *Optics express*, vol. 23, no. 17, pp. 22 714–22 722, 2015.
- [24] A. Signorini, S. Faralli, M. A. Soto, G. Sacchi, F. Baronti, R. Barsacchi, A. Lazerri, R. Roncella, G. Bolognini, and F. Di Pasquale, "40 km long-range raman-based distributed temperature sensor with meter-scale spatial resolution," in *Optical Fiber Communication Conference*. Optical Society of America, 2010, p. OWL2.

Rubén Ruiz-Lombera received the degree in Telecommunication Technical Engineering (Electronic Systems) in 2011, the degree in Telecommunication Engineering in 2012, and the Master degree in Information Technologies and Mobile Networks from the University of Cantabria (Spain). He is currently doing his PhD in the area of distributed fiber sensors, especially those based on Brillouin scattering.

Ismail Laarossi was born in 1987. He obtained the Telecommunication Technical Engineering Degree (Electronic Systems) in 2011, the degree in Telecommunication Engineering in 2013 and the Physics, Instrumentation and environment Master Degree in 2014, at the University of Cantabria (Spain). He is currently doing his PhD thesis and collaborating in the Photonics Engineering Group, in the area of distributed temperature sensing, especially those based on Raman effect.

Luis Rodríguez Cobo received the degree in telecommunication engineering from the University of Cantabria, Spain, in 2009, where since 2009. In 2013 he obtained his PhD. degree in optical sensors for smart structures working at the Photonics Engineering Group (GIF), Department of electronic Technology Industrial Automation and System Engineering. He was also awarded with the PhD extraordinary award in 2015 for his research carried out during his studies. His research is about applying optical technologies to structural health monitoring systems in different application fields such as energy, industrial applications and environment monitoring.

María Ángeles Quintela was born in Santander, Spain, in 1974. She received both the Telecommunications Technical Engineering degree and the Telecommunications Engineering degree from the University of Cantabria, Spain. In 1998, she joined the University of Cantabria as a Lecturer. Her teaching topics include electronic components and optical communications. In 2005, she received the Ph.D. degree from the University of Cantabria. Her main research is on computer modelling and experimental characterization of fiber lasers. She has co-authored more than 60 papers, presented in conferences and scientific journals.

José Miguel López-Higuera (M'93SM'98) was born in February 1954, in the village of Ramales de la Victoria, Cantabria, Spain. He obtained the Telecommunication Technical Engineering degree from the Universidad Laboral de Alcalá de Henares, Madrid, Spain and the Telecommunication Engineering degree from the Universidad Politécnica de Madrid (UPM), Madrid, Spain. He received the Ph.D. degree in telecommunication engineering, with an extraordinary award, from UPM. He founded and is the Head of the Photonics Engineering Group of the TEISA Department in the University of Cantabria. Currently, he works in the development of Photonics Instrumentation, photonic/optical fibre sensor systems for civil engineering, electrical power, environmental and smart structures and for optical diagnostics for a wide range of applications. He has directed more than 50 R&D projects and has written or co-written more than 400 publications in the form of books, chapters of books, papers and conferences, both national and international, and obtained ten patents. He is the Editor and Co-author of several books, including i) "Optical Sensors", UC, 1998; ii) the "Handbook of Photonic Sensing Technology", Wiley and Sons, New York, NY, USA, 2002 and iii) he is the co-editor of the book "Engineering a High-Tech Business: Entrepreneurial experiences and Insights", published by SPIE-Press, USA, 2008. Prof. López-Higuera is Senior Member of the IEEE and member of the IEE, SPIE and OSA.

Jesus Mirapeix received the masters degree in telecommunications engineering in 2000, and the Ph.D. degree with a focus on quality monitoring of welding processes by means of plasma optical spectroscopy, in 2007. Since 2012, he has been an Associate Professor with the Photonics Engineering Group, Department of Electronic Technology, Industrial Automation and System Engineering, University of Cantabria, with teaching and R&D duties. He is currently involved in distributed sensor systems based on stimulated Brillouin scattering. He is the Co-Founder of SADIQ Engineering, a company offering products and services for welding, automation, and monitoring. His research interests include fiber optic sensors and processing strategies for on-line quality assurance of both arc and laser welding processes, with application in the manufacturing of components for the aerospace and nuclear sectors.