

UHF Power Conversion with GaN HEMT Class-E² Topologies

José A. García, M. Nieves Ruiz, David Vegas, María Pampín and Ángel Mediavilla

Department of Communications Engineering, University of Cantabria, Santander,

Spain, 39005, (34) 942 202218, joseangel.garcia@unican.es

Abstract — This paper reviews the use of UHF double class-E (class-E²) topologies for dc/dc power conversion. After introducing this attractive resonant converter in the context of the time-reversal duality principle, two different lumped-element networks are described for appropriately terminating the drain of the switching devices. Recent implementation examples, taking advantage of GaN HEMT processes, are then presented. The potential for a fast dynamic response is validated (with a slew rate over 2 V/nS), while also the feasibility for an appropriate operation without requiring external RF gate driving signals. A solution for approximating a load-insensitive operation is finally exposed.

Index Terms — Class-E, dc/dc conversion, GaN HEMTs, microwave, resonant converters, soft switching, UHF.

I. INTRODUCTION

Power electronics applications have been demanding for efficient power converting topologies, able to switch at frequencies in the MHz or even in the GHz range. This has been mainly motivated by the interest in miniaturization [1], but also by the irruption of modern systems with demanding specifications. That is the case, for instance, of the non-contact connection required between the input and output circuits of the converter in a wireless power transmission link [2], or of the very fast dynamic response to be expected from the one to be employed as envelope modulator in a wireless signal transmitter [3]. The advantages associated to the introduction of GaN HEMT technology are being decisive in this evolution.

Achieving competitive efficiency values in dc/dc converters operating at VHF, UHF or microwave bands, requires minimizing the frequency dependent switching loss mechanisms. This is one of the reasons why class-E operation [4], with zero voltage and zero voltage derivative switching (ZVS and ZVDS), has become highly attractive. Several solutions have been proposed at HF and VHF bands [5], but also recently at UHF [6, 7] or the low microwave band [8]. In this paper, attention is put to the use of double class-E lumped-element topologies for dc/dc power conversion at the UHF band. Different

implementation examples, based on the use of RF GaN HEMT devices, are presented and discussed.

II. CLASS-E² RESONANT CONVERTER

Obtained by cascading an inverter with a rectifier, the dc input power is first transformed in a resonant converter into ac power, to then convert it back into the desired dc power at the output. In the particular case of the double class-E or class-E² topology, proposed by Kazimierczuk in [9], ZVS and ZVDS conditions are simultaneously forced in the inverting and rectifying devices, avoiding the impact of switching loss mechanisms and theoretically leading to a 100%-efficient performance.

In Fig. 1, one of the original class E² topologies in [9] is presented, where the rectification is of active or synchronous type (at UHF and beyond, high current and voltage Schottky diodes are hard to find, reason why a transistor-based rectifier may be mandatory for medium or high power implementations). The rectifier and inverter waveforms show a time-reversal duality [10], with the rectifying transistor working on the third quadrant of its IV characteristic when in ON-state.

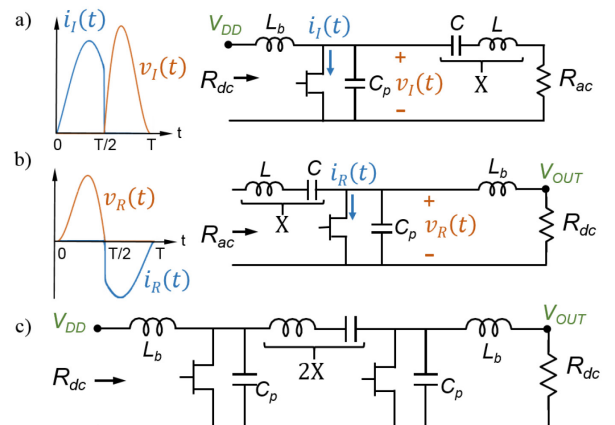

Fig. 1. a) The class-E inverter, b) a class-E synchronous rectifier, and c) a class-E² DC/DC converter obtained when cascading a) and b) [9, 11]. At UHF band, the parallel capacitance (C_p) is generally provided by the device output capacitance. Characteristic waveforms have been also included for an ideal 100% efficiency operation.

III. UHF TOPOLOGIES

The ideal LC series network of Fig. 1 may not be appropriate for UHF operation, due to the undesired reactive parasitics in the coil and capacitor equivalent circuits. Solutions for the network interconnecting the drain terminals of the switching devices in Fig. 1c) have been proposed in [6-7], based on a multi-resonant or poly-harmonic impedance synthesizing approach and on the self-resonant characteristic of a real high Q coil.

In the first case, represented in the schematic of Fig. 2a), the open circuit conditions at the most relevant harmonics (second and third), together with the nominal impedance value at the fundamental are synthesized one by one, following a lumped-element version of the transmission line topology proposed in [12]. On the other, see Fig. 2b), a high Q coil, self-resonating between the second and third harmonics [13] is introduced for approximating the open circuit terminations, while combined with capacitors for forcing the nominal impedance at the switching frequency. While the second technique only provides a rough approximation to class-E operation, it leads to a higher power density implementation. Requiring a reduced number of passive elements, extra losses due to their undesired parasitic effects may be also avoided.

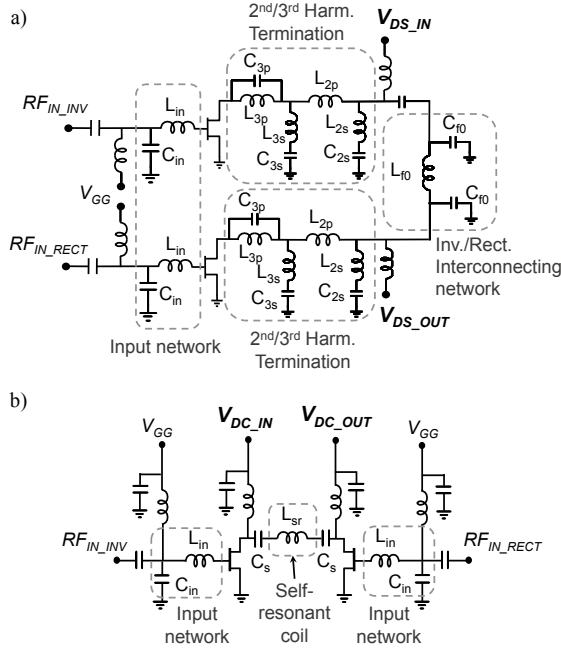

Fig. 2. Schematics of UHF class- E^2 converters using the a) poly-harmonic impedance synthesizing approach [6] and b) the self-resonant coil-based network [7].

IV. IMPLEMENTATION AND CHARACTERIZATION RESULTS

In Fig. 3, photographs with implementation examples of the previously described topologies are shown. The poly-harmonic solution was designed to operate at 780 MHz [6], while an improved version of the self-resonant coil solution in [7] was also operated around 1 GHz. GaN HEMT devices, packaged or die, from Cree Inc. were employed in both cases, together with multilayer capacitors from ATC and Air Core coils from Coilcraft.

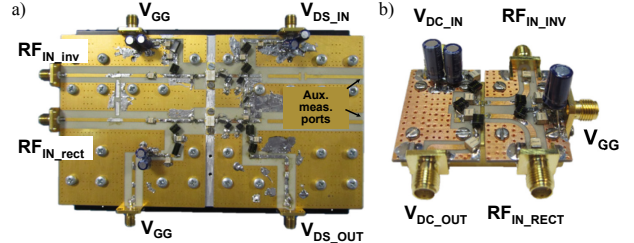

Fig. 3. Photographs with implementation details of the GaN HEMT-based UHF dc/dc converters. The design frequencies are a) 780 MHz [6] and b) 1 GHz [11].

Several output voltage control strategies may be applied to these UHF resonant converting topologies. Frequency modulation was proposed together with the original schematic in [9], taking full profit of the frequency characteristic above resonance of the interconnecting LC network in Fig.1 c). In [5], an ON/OFF control strategy was employed instead. Advantage was taken from the duty cycle of a carrier burst waveform for driving the inverter.

A. Output voltage profile

For the UHF converter in Fig. 3a), an ON/OFF control was implemented, synchronously driving the rectifier with a similar waveform [6]. A peak efficiency of 72% was obtained for a 100% duty cycle, with an output voltage profile following it in a highly linear way, as it may be appreciated in Fig. 4a). The die converter in Fig. 3 b) was controlled with frequency. Similar profiles are plotted versus the switching frequency in Fig. 4b), where a peak value close to 80% was measured, just for a few dBs below the peak in the output voltage. The voltage profile decreases with frequency, as in [7], but with improved linearity and a more efficient performance [11].

B. Dynamic response

Due to the impact of the reconstruction filter, required for recovering the desired dc voltage from the pulses at the rectifier output, the measured values for the bandwidth and slew rate of the converter in Fig 3a) were limited to only 11 MHz and 630 V/ μ S.

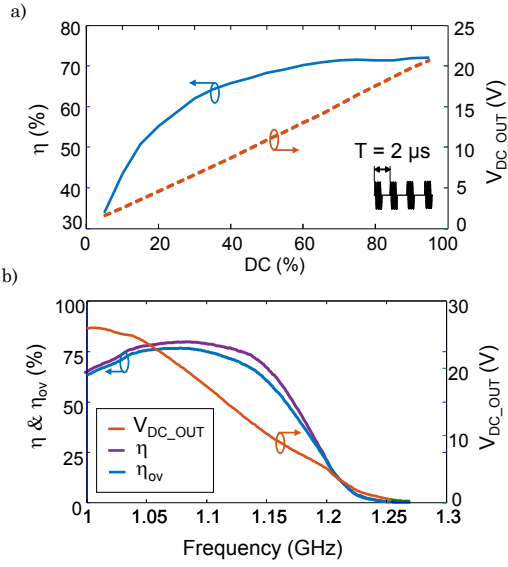

Fig. 4. Measured results (output voltage and efficiency) for UHF dc/dc converters implementing different control techniques: a) PWM carrier bursts [6] and b) frequency modulation [11]. The overall efficiency calculation, η_{ov} , includes also the power of the gate driving signals.

The frequency control implemented in [7] avoids the need for such a filter, allowing a much faster dynamic response from a resonant converter switching at the UHF band. With an improved design for the drain terminal dc network [11], a better performance with respect to the one reported in [7] has been possible. In Fig. 5, the characterization results for the converter in Fig. 3b) are presented in terms of large-signal bandwidth and slew rate. The frequency deviation of the FM signal, driving the gate terminals of the inverting and rectifying GaN HEMTs, was carefully adjusted in each case to force a significant variation in the output voltage. The estimated values for the bandwidth and slew rate are of approximately 56.5 MHz and 2.25 V/nS, respectively. As far as the authors know, these values are among the highest reported for resonant power converters. A bandwidth of tens of MHz makes this implementation attractive for the reproduction of communication signal envelopes, as required in modern envelope tracking wireless transmitters.

V. LIMITATIONS AND POSSIBLE IMPROVEMENTS

A. RF driving signal

For power electronics specialists, interested in a high frequency operation of their converters, the need for an RF driving signal may be certainly problematic. Additional and not simple circuitry for generating and properly modulating a UHF carrier with the control voltage would be required.

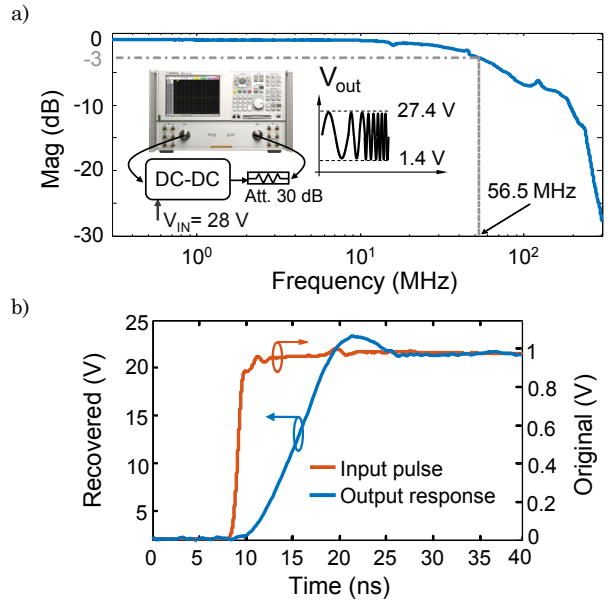

Fig. 5. Measured results of a) large-signal bandwidth and b) slew rate for the 1 GHz FM-controlled GaN HEMT class-E² converter of Fig. 3b. Details of the FM envelope coding technique were included in [7].

This is the reason why a self-oscillating and self-synchronous converter was studied and demonstrated in [8]. The gate driving signal was avoided in the rectifier, taking fully advantage of the gate-to-drain capacitance of the employed GaN HEMT [14] with the aid of a reflective gate termination at the fundamental. A similar combination, together with a modification of the gate biasing voltage was applied to the inverter in order to force its free-running oscillation in the desired band.

In Fig. 6, the measured output voltage and efficiency profiles are presented, together with the oscillating frequency. The nonlinear dependence of a GaN HEMT equivalent input capacitance with the gate-to-source biasing voltage allowed the desired output voltage control.

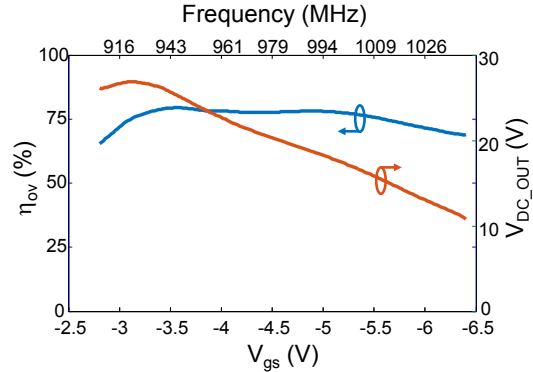

Fig. 6. Measured results (output voltage, efficiency and oscillating frequency) for the self-oscillating and self-synchronous converter.

B. Load-invariant operation

Implementing output voltage control loops may turn extremely difficult when switching at UHF frequencies and beyond. If considering the potential use of the class-E² converter as envelope modulator, special care should be taken regarding the sensitivity of the output voltage for the topology in Fig. 1c) to variations in its loading condition. Being that the current consumption from the RF power amplifier is highly dependent on the value of the input signal envelope, the described class-E² converters may be forced to operate not only in a non-efficient mode, but also in non-safe conditions for the active devices [15].

Alternative topologies for the class-E inverter and rectifier may be introduced as a solution to this problem. They could help reducing the sensitivity of the output dc voltage to load variations, while preserving at the same time a good efficiency. In Fig. 7, the evolution with load resistance of the output voltage amplitude for a modified class-E inverter designed at 915 MHz is presented. A topology derived from [15] was selected, also amenable for its use in rectifying mode [16].

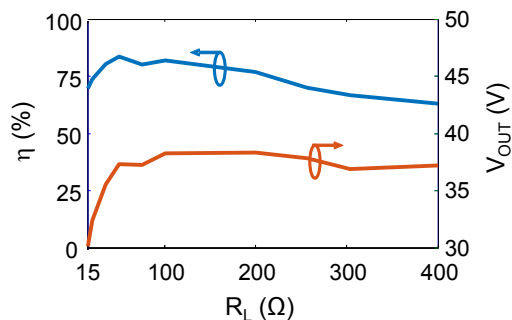

Fig. 7. Measured evolution of output voltage amplitude and efficiency for a class-E inverter with reduced sensitivity to load variations.

VI. CONCLUSION

The use of UHF lumped-element topologies for the implementation of class-E² resonant converters has been reviewed in this paper. Thanks to the implementation with GaN HEMT devices, the potential for a very fast dynamic response has been validated, while also the feasibility for an appropriate operation without requiring external RF gate driving signals or under varying loading conditions. A lot of work is still needed for improving their dynamic performance, power density and efficiency figures in order to make it a competitive alternative for real applications. Available devices with gate lengths of 250, 150 or 100 nm could allow implementations at higher frequency bands [17], although their not negligible ON-state resistance would limit the efficiency performance.

REFERENCES

- [1] F. Waldron, R. Foley, J. Slowey, A. N. Alderman, B. C. Narveson, S. C. O'Mathuna, "Technology Roadmapping for Power Supply in Package (PSiP) and Power Supply on Chip (PwrSoC)," *IEEE Trans. Power Electronics*, vol. 28, no. 9, pp. 4137-4145, Sept. 2013.
- [2] N. Borges *et al.*, "Wireless Power Transmission: R&D Activities Within Europe," *IEEE Trans. on Microwave Theory and Tech.*, vol. 62, no. 4, pp. 1031-1045, April 2014.
- [3] E. McCune, "Envelope Tracking or Polar—Which Is It? [Microwave Bytes]," *IEEE Microwave Mag.*, vol. 13, no. 4, pp. 34-56, May-June 2012.
- [4] N. O. Sokal and A. D. Sokal, "Class E, A New Class of High-Efficiency Tuned Single-Ended Switching Power Amplifiers," *IEEE J. Solid-State Circ.*, vol. SC-10, no. 6, pp. 168-176, June 1975.
- [5] D. J. Perreault, H. Jingying, J. M. Rivas, H. Yehui, O. Leitermann, R. C. N. Pilawa-Podgurski, A. Sagneri and C. R. Sullivan, "Opportunities and Challenges in Very High Frequency Power Conversion," *2009 Twenty-fourth Annual IEEE Applied Power Electron. Conf. and Exp. (APEC)*, pp. 1-14, March 2009.
- [6] J. A. García, R. Marante, and M. N. Ruiz, "GaN HEMT Class E² Resonant Topologies for UHF DC/DC Power Conversion," *IEEE Trans. Microwave Theory & Tech.*, vol. 60, no. 12, pp. 4220-4229, Dec. 2012.
- [7] J. A. García, R. Marante, M. N. Ruiz, and G. Hernández, "A 1 GHz Frequency-controlled Class E² DC/DC Converter for Efficiently Handling Wideband Signal Envelopes," *IEEE MTT-S Int. Microw. Symp. Dig.*, June 2013.
- [8] I. Ramos, M. N. Ruiz, J. A. García, D. Maksimović and Z. Popović, "GaN Microwave DC-DC Converters," *IEEE Trans. Microwave Theory & Tech.*, vol. 63, no. 12, pp. 4473-4482, Dec. 2015.
- [9] M. K. Kazimierzczuk, J. Jozwik, "Resonant DC/DC Converter with Class-E Inverter and Class-E Rectifier," *IEEE Trans. Ind. Electron.*, vol. 36, no. 4, pp. 468-478, Nov. 1989.
- [10] D. C. Hamill, "Time Reversal Duality and the Synthesis of a Double Class E DC-DC Converter," in *21st Power Electron. Specialist Conf. (PESC)*, 1990, pp. 512-521.
- [11] J.A. García and Z. Popovic, "Class-E Rectifiers and Power Converters," *IEEE MTT-S International Microwave Symp.*, Honolulu, USA, 4-9 June 2017.
- [12] T. B. Mader, Z. B. Popovic, "The transmission-line high-efficiency class-E amplifier," *IEEE Microw. Guided Wave Lett.*, vol. 5, no. 9, pp. 290-292, Sep 1995.
- [13] R. Negra and W. Bächtold, "Lumped-element Load-network Design for Class-E Power Amplifiers," *IEEE Trans. Microwave Theory & Tech.*, vol. 54, no. 6, pp. 2684-2690, June 2006.
- [14] M. Roberg, T. Reveyrand, I. Ramos, E. A. Falkenstein and Z. Popovic, "High-Efficiency Harmonically Terminated Diode and Transistor Rectifiers," *IEEE Trans. Microwave Theory Tech.*, vol. 60, no. 12, pp. 4043-4053, Dec. 2012.
- [15] M. K. Kazimierzczuk and K. Puczkó, "Class E with an Inductive Impedance Inverter," *IEEE Trans. Industrial Elect.*, vol. 37, no. 2, pp. 160-166, April 1990.
- [16] M. N. Ruiz, D. Vegas, J. R. Pérez and J. A. García, "GaN HEMT Class-E Rectifier for DC+AC Power Recovery," *IEEE MTT-S Int. Microw. Symp.*, June 2017.
- [17] I. Ramos and Z. Popovic, "A Microwave Monolithically Integrated Distributed 4.6 GHz DC-DC Converter," *IEEE MTT-S Int. Microw. Symp.*, June 2016.