

Measurement results and improvements on an open EPR system

G. Sacco^{3,4}, C. De Angelis^{1,4}, G. De Angelis¹, S. Della Monaca^{1,4}, L. Di Trocchio⁵, P. Fattibene¹, L. Ficcadenti⁴, M. Lucentini^{1,4}, A. Mostacci^{2,4}, L. Piersanti⁴, S. Pisa³, E. Pittella³, M. C. Quattrini^{1,4}, F. Santavenerè^{1,4}

1 Istituto Superiore di Sanità, Roma, 00161, Italy

2 Università "La Sapienza", Dip. Scienze di base e applicate per ingegneria, Roma, 00161, Italy

3 Università "La Sapienza", Dip. Ing. dell'inf., elettronica e telecomunicazioni, Roma, 00184, Italy

4 Istituto Nazionale di Fisica Nucleare, Sezione Roma 1, Roma, 00161, Italy

5 Univ. Bordeaux, IMS, CNRS UMR 5218, F-33405 Talence, France

e-mail: giulia.sacco@outlook.com

Keywords: (EPR, open resonator, modulation coil)

Electron paramagnetic resonance (EPR) is a spectroscopic method that allows measuring paramagnetic species, like stable radicals. EPR analysis has been proposed as a potential tool for non-invasive melanoma diagnosis [1]. Moreover, the EPR measurements can help to estimate the dose absorbed by people exposed during a nuclear disaster, detecting the number of radicals induced in their mobile phones due to the exposition. Using conventional closed microwave cavities, for the melanoma diagnosis the nevi must be extracted by biopsy in order to be examined and the phone display must be fragmented to be introduced inside the resonator. The aim of this work is to develop a system, compatible with the spectrometer Bruker Elexys E500, able to preserve sample integrity, i.e. allowing in principle to avoid the biopsy for a non-invasive melanoma diagnosis and the fragmentation of the display. The system uses an X-band resonant metallic cavity with a slit, realized on one side, for the leak of the excitation magnetic field and a Helmholtz coil pair. The resonator allows measuring a sample lodged outside the cavity, while the coil produce a 100 kHz modulated field that encodes the output signal at a particular frequency and increases the SNR.

The design of the cavity has been performed using the software Microwave Studio (CST). Fig. 1 shows the final structure. The resonator was designed in order to reach a high-unloaded quality factor, Q_u , and to work with modes such that along the cavity sidewall, the magnetic and the electric fields have their maximum and minimum value, respectively [2].

The coils, instead, were designed to obtain a field enough uniform and strong in the sample volume. They are realized connecting in series on the same axis two solenoids, at a distance $d = 7$ cm, carrying the current in the same direction. Each coil has a radius $R = 5.2$ cm and consists of 100 turns of a copper wire with a radius of $250 \mu\text{m}$ (Fig. 2).

The efficacy of the system was tested by using, as sample material, a powder of stable free-radical molecules (DPPH), positioned on an adhesive support in contact with the slit. Fig. 3 shows the recorded signal. In order to increase the system performances, the matching of the coil has been improved. To this purpose, first, the coil impedance has been measured, with an LCR meter, as a function of the frequency. Then a circuital model that fits the impedance data around the central frequency of 100 kHz has been realized (Fig. 4). The resistance R is the static ones of the coils while the L inductance is that measured at 100 kHz. The R_1 resistance in the second branch takes into account the parasitic effects of the structure. Both measurements and the model evidence at 100 kHz an impedance modulus of about $2.5 \text{ k}\Omega$ that strongly reduces the coil flowing current and the generated magnetic field. A possible way for solving that problem is to put an adequate value capacitance, in series to the circuit of Fig. 4, in order to cancel the inductive term at the frequency of 100 kHz and consequently to reduce the impedance modulus. Simulations of the proposed structure, performed using the software AWR, allowed finding an optimal value of capacitance of about 630 pF . In this manner, the estimated current reaches about 110 mA at 100 kHz and is able to produce a magnetic field of about 1.5 G at the coil axis center.

[1] E. Cesareo et al., PLoS ONE 7(11)

[2] L. Di Trocchio, 18th Int. Conf. on Solid State Dosimetry, July 2016, Germany.

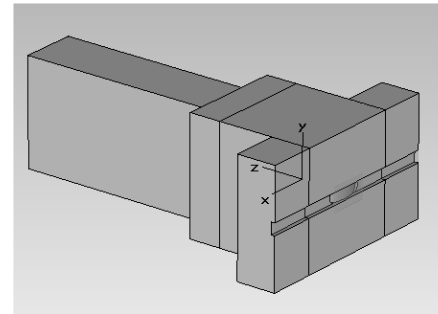

Figure 1. Sketch of the cavity designed with CST.

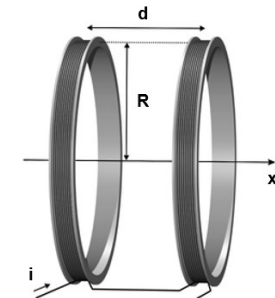

Figure 2. Coil system for the generation of the 100 kHz modulation field.

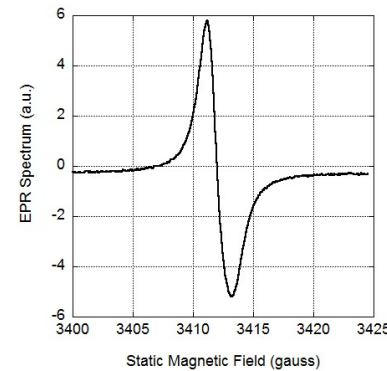

Figure 3. Output signal of the EPR for the DPPH sample placed in contact with the resonator slit.

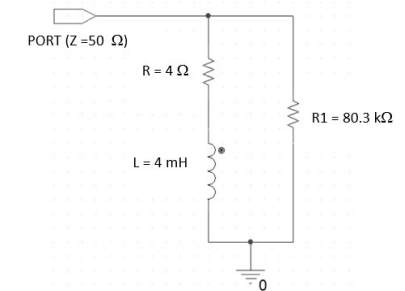

Figure 4. Circuitual model of the coil system around the 100 kHz frequency.