

**Design and Analysis of a Net-Zero Energy House and its Power
System for Libya**

By

Gamal Ali Alamri. EE

**A Thesis submitted to School of Graduate Studies in
Partial fulfillment of the
Requirements for the degree of
Master of Engineering**

**Faculty of Engineering and Applied Science
Memorial University of Newfoundland**

May 2017

St. John's, Newfoundland, Canada

Abstract

This thesis focuses on an optimal design for a Net-Zero Energy house in the hot environment of Libya. Such work involves two main design steps. First is the design of the house body and direction based on seasonal sun height and sun East-West track (E-W Track). Second is the design of system for house heating and cooling by implementing multi- renewable energy. The first step of the design uses the sun's heat based on summer-winter seasons. In summer, the design prevents high sun heat from entering the house by improving the house's insulation, thus reducing cooling energy demand. In winter, the design utilizes the sun's heat and E-W track in heating the house by allowing optimal sunlight to enter the house from the south façade by increasing the number of windows and reducing the ultimate energy required for heating. The second step of the design uses clean energy resources as the only house energy source. Several types of software are used in the house design and energy analysis including BEopt, Energy 3D, Homer, and Mat-Lab/Simulink. Safety precautions and requirements of installing the hybrid power system are carefully followed and implemented. The selected house for the design is a concrete house located in the hot environment of Tripoli, Libya. This new house design provides comfortable indoor conditions associated with a low energy consumption of $\leq 50\%$ of a regular home, cost reduction, and environmental protection. The layout of the chapters of this thesis is chapter one: introduction, literature review, and design criteria and specifications; chapter two: house design, thermal simulation and analysis; chapter three: sizing of the hybrid power system; chapter four: electrical details and dynamic simulation of the hybrid power system; chapter five: safety issues, bus voltages, and suggestions; and chapter six: conclusions.

Dedicated to my loving family

Acknowledgement

Thesis acknowledgement, First and foremost, I am grateful to Allah for the good health and well-being that were necessary to complete this research.

I would like to express my sincere gratitude to my advisor Prof. Tariq Iqbal for the continuous support of my MSc study and related research, for his patience, motivation, and immense knowledge. His guidance helped me in all the time.

I am also grateful to my parents Mr. Ali and Mrs. Salma and my brothers and my sisters for the unceasing encouragement, support and attention. I am also grateful to my darling wife Mrs. Mona who supported me all the time through this venture.

I also place on record, my sense of gratitude to one and all, who directly or indirectly, have lent their hand in this project.

I would also like to extend my thanks to my friends and colleagues for their continuous supporting during my graduate program.

I would like to gratefully acknowledge to my country Libya that gave me the scholarship for continuing in my Master degree and special thanks to the engineers whom work at the electrical general company for providing me all information related to this research.

Table of Contents

Abstract	i
Acknowledgement	ii
Table of Contents	iv
List of Tables	v
List of Figures	x
Nomenclature	xi
1. Introduction	1
1.1 Background and Motivation	1
1.2 Net-Zero Energy Buildings – Definitions.....	9
1.3 Net-Zero Energy Houses – Examples	10
1.4 Barriers to Net-Zero Energy Buildings in Libya	16
1.5 Literature Review	21
1.5.1 Energy consumption in buildings	22
1.5.2 Houses Energy Consumption Survey in Libya	22
1.5.3 Design for Climate	23
1.5.4 Libya’s Climate, Average Weather, Temperatures, Rainfall, Sunshine, Humidity, Graphs.....	24
1.6 Motivation	27
1.7 Feasibility and case studies	27
1.7.1 Feasibility	28
1.7.2 Case Study.....	29

1.8 Construction System	29
1.9 Thermal Mass	29
1.10 Thermal Mass is Most Useful in Hot Climate	30
1.11 International Residential Code for Building	32
1.12 Specification for Concrete Masonry Units	32
1.13 Cooling Homes, Buildings in Hot, Humid Climates	34
1.14 Design criteria and specifications of the house	35
1.15 Framework and objective of the research	35
1.16 Overview for the next chapters	37
2. House Design, Thermal Simulation and Analysis in BEopt and Energy 3D software.....	38
2.1. Introduction	38
2.2. BEopt Software based on Conventional House Design	38
2.2.1. Geometry Screen	44
2.2.2. Site Screen	44
2.2.3. Input Screen	44
2.2.4. Walls	45
2.2.5. Ceiling/Roofs	45
2.2.6. Air Flow.....	45
2.2.7. Windows	45
2.2.8. Thermal Mass	46
2.2.9. Major Appliances	46
2.2.10. Lighting	46
2.2.11. Space Conditioning	47
2.2.12. Water Heating	47
2.3. R- Value and U- Value Explanation	47
2.4. Specification of the House	48
2.5. General Passive Design Strategies	53
2.5.1. Typology/Shape	53

2.5.2. Orientation	53
2.5.3. Shading	54
2.5.4. Walls Insulation	55
2.5.5. Roof Insulation	55
2.6. Design and Energy Analysis of the House	56
2.6.1. Design the House	56
2.6.2. Energy Analysis of the House	57
2.7. House Design Fundamental Using BEopt Software	57
2.7.1. Walls	60
2.7.2. Ceiling/Roof	60
2.7.3. Foundation Floor	60
2.7.4. Thermal Mass	60
2.7.5. Windows and Doors	61
2.7.6. Air Flow	61
2.7.7. Major Appliances	61
2.7.8. Lighting	61
2.7.9. Space Conditioning	62
2.7.10. Water Heating	62
2.8. Output in BEopt Software	63
2.9. Comparison of Measurement and Simulation of Conventional and Passive House	65
2.10. Design a Concrete Passive House (Sash)	66
2.11. House Design Using Energy 3D Software	69
2.11.1. Energy 3D Software Definition	69
3. Sizing of a Hybrid Power System	75
3.1. Introduction	75
3.2. City of Tripoli- Libya	76
3.3. Renewable Energy Potential in Libya	78
3.4. Assumption and Model inputs	79

3.4.1. Load	79
3.4.2. Hybrid Power System for a House in Libya	80
3.5. Standard for Design	81
3.6. Homer Software Definition	81
3.7. Wind Energy and Solar Resources	82
3.7.1. Solar Radiation	82
3.7.2. Wind Resource	83
3.7.3. Wind Power Working	85
3.7.4. Wind Turbine Specification	86
3.7.5. Wind Turbine Curve	88
3.7.6. Wind Turbine Modeling	89
3.8. Solar Energy	90
3.8.1. PV Module and Battery Specification	91
3.8.2. PV Array and Its Calculations	93
3.8.3. Factors That Impact the Operation of the Solar Module	94
3.9. Storage Battery System	96
3.9.1. Battery Information	98
3.10. Components and Their Tasks	98
3.11. Converter Device	100
3.12. Charge Controller	101
3.13. Wind Turbine and PV Panel Electric Production	101
3.14. Simulation Results from Homer Software	102
4. Electrical Details and Dynamic Simulation of Hybrid Power System	105
4.1. Background and Motivation	105
4.2. Wind Turbine Modeling	106
4.2.1. Permanent Magnet Synchronous Generator	106
4.3. PV Modeling	107
4.4. The DC/DC Boost Converter	108
4.5. Proposed System	109
4.6. Modeling of Wind/ PV Hybrid Power System in Mat-Lab/ Simulink	110

4.7. Simulation Results from MATLAB/Simulink	112
5. Safety Issues, bus Voltages and Suggestions	113
5.1. Wind Turbine Installation	113
5.2. DC Power Cable Sizing	114
5.3. Solar Panel Installation	113
5.4. Battery Bank System and Inverter	117
5.5. Charge Controller	118
5.6. Safety Issues and the Suggestions	119
6. Conclusion	121
6.1. Contributions	122
6.2. Recommendations for Future Research	123
References	125

List of Tables

Table 1.1: Zero Energy House in Hot, Humid Climates	17
Table 1.2: Information on the Climate of Some Libyan Cities	26
Table 2.1: Shows the Design using Different Software and Energy Consumption Comparing to Bells House from the Grid	66
Table 3.1: Monthly Average Wind Speed of Tripoli from Homer Simulation	78
Table 3.2: Shows the Characteristics of the 400w Air-X Wind Turbine	80
Table 3.3: Components System Considered	93
Table 5.1: Shows the Sizing of Cables and Breakers	99
Table 5.2: Characteristics of 200w Mono-Crystalline PV Panels	101
Table 5.3: Characteristics of Magnum Inverter	102

List of Figures

Fig. 1.1. Concrete passive house in a hot climate	14
Fig. 1.2. Concrete passive house for two families in Qatar	15
Fig. 1.3. Concrete passive house in Qatar	15
Fig. 1.4. Concrete passive house built in Saudi Arabia	16
Fig. 1.5. Passive house in Minnesota, US using sustainable elements	17
Fig. 1.6. Diagram of the hybrid system used to power the house	21
Fig. 1.7. Concrete passive house in a hot climate.....	22
Fig. 1.8. Concrete passive house in a hot climate	22
Fig. 1.9. Concrete passive house in Qatar	22
Fig. 1.10. Concrete passive house in Qatar	22
Fig. 1.11. Concrete Passive Solar House in a hot climate	24
Fig. 1.12. This map shows Libya its located near the cancer orbit line.....	26
Fig. 1.13. This graph indicates the climate in Tripoli City – Libya	29
Fig. 1.14. Annual temperature and precipitation	29
Fig. 1.15. Typical unit sizes and shapes of concrete masonry units	36
Fig. 1.17. Types of concrete used in Libya	36
Fig. 2.1. The front façade	46
Fig. 2.2. The south façade	46
Fig. 2.3. The back façade	46
Fig. 2.4. The north façade	46
Fig. 2.5. Dimensions of the House	48
Fig. 2.6. Function of overhangs in summer and winter	50
Fig. 2.7. Design House using BEopt software	54
Fig. 2.8. Shows the Parameters of the House	55
Fig. 2.9. Output in design mode	61
Fig. 2.10. Output in D-View	62
Fig. 2.11. Monthly output	63
Fig. 2.12. Shows Result simulation of House as Sash	64

Fig. 2.13. Output in D-View	65
Fig. 2.14. Monthly Output in D-view	66
Fig. 2.15. Profile Output in D-View	66
Fig. 2.16. Shows the House Designed	68
Fig. 2.17. Shows the House Design Costs	69
Fig. 2.18. Shows the Annual Energy Consumption of House	73
Fig. 3.1. The Location of Libya and City of Tripoli	78
Fig. 3.2. Hourly Load Profile for The House	80
Fig. 3.3. Hybrid Power System from Homer Simulation	81
Fig. 3.4. Solar Radiation Profile for Tripoli- Libya Plotted in Homer	83
Fig. 3.5. Wind Speed Profile for Tripoli- Libya Plotted in Homer	85
Fig. 3.6. Wind Turbine Installation and Its Parts	87
Fig. 3.7. Wind Power Output(W) and Wind Speed (m/s)	88
Fig. 3.8. Energy Conversion from Wind Turbine to Electricity	89
Fig. 3.9. Solar Panel 200 W Mono-Crystalline and Its Dimensions	91
Fig.3.10. PV System Input in Homer Software	92
Fig 3.11. Connection of Solar Modules in Series- Parallel	93
Fig. 3.12. Selected Battery Type for the Simulation in Homer	96
Fig. 3.13. Version 6FM200D Battery, www.version-batt.com	97
Fig. 3.14. Components of a Hybrid Power System	98
Fig. 3.15. Circuit Diagram of the Charge Controller	100
Fig. 3.16. Expected Electrical Performance Result	101
Fig. 3.17. Homer Simulation and Results	104
Fig. 3.18. Homer Optimization Results with Modified Sensitivities Variables	104
Fig. 3.19. Cash Flow Summary of Proposed Hybrid Power System of House	105
Fig. 4.1. Wind Turbine and Its Permanent Magnet Synchronous Generator	107
Fig. 4.2. Solar PV MATLAB/Simulation Model	108

Fig. 4.3.	Block Diagram od DC/DC Coveter	109
Fig. 4.4.	Block Diagram of AC Shunt Load of House Connected to Hybrid off-Grid	110
Fig. 4.5.	Modeling and Simulation of Hybrid PV/Wind Energy System	111
Fig. 4.6	Load current (A) vs. time (m/s) in inverter	112
Fig. 4.7	Inverter voltage vs. time	113
Fig. 4.8	Charging Voltage of the Battery	114
Fig. 5.1.	Wind Turbine and Its Location	113
Fig. 5.2.	Solar Panels and Its Installation	115
Fig. 5.3.	MPPT Charge Controller	118

Nomenclature

Abbreviations

GHGs	: Green House Gases
NZEB	: Net-Zero Energy Buildings
GCC	: Gulf Cooperation Council
GSAS	: Global Sustainability System
EUI	: Energy Use Intensity
HVAC	: Heating Ventilation Air Conditioning
IEA	: International Energy Agency, 2014
ZCH	: Zero Carbon Hub, 2014
GWH	: Giga Watt Hour
BSH	: Bausparkasse Schweich Hall (Germany Building Society)
CMUs	: Concrete Masonry Units
IRC	: International Residential Code
ICF	: Insulated Concrete Form
BTUs	: British Thermal Units
BEopt	: Building Energy Optimization
ECL	: Energy Consumption Levels
ACI	: American Concrete Institute 2014
AC	: Alternating Current
DC	: Direct Current
PV	: Photovoltaic Panel

AGM : Absorbed Glass Mat
PCM : Phase Change Material
CFL : Compact Fluorescent Lamps
DOE : Department of Energy
CO2 : Carbon Dioxide
UK : United Kingdom
US : United State
WTG : Wind Turbine Generation
AH : Ampere Hour
COE : Cost of Energy

List of Symbols

Symbol	Parameter	Unit
R-Value	Material's Capacity to Resist Heat Flow	w/m^2
BTU	British Thermal Units	Joules
F^0	Fahrenheit Temperature	Kelvin
C^0	Celsius Temperature	Centigrade degrees
U-Value	The Coefficient of Transmission of heat	—
A	Area of the House	m^2
AC	Alternating Current	Ampere
DC	Direct Current	Ampere
I_{sc}	Short Circuit Current	Ampere
P_w	Wind Power	W
C_p	Turbine Power Coefficient	—
V	Wind Speed	m/s
ρ	An Air Density	Kg/m^3
A	Rotor Swept Area	m^2
K. E	Kinetic Energy	m/v
V_m	Mean Speed	m/s
σ	Standard Deviation of the Wind Speed	m/s
L	Inductor Coil	Ohm
C	Capacitor	μf
$A_{array\ size}$	Area of PV Panels	m^2

Cost	Cost of Components	\$
R_L	Load Resistance	Ohm
D	Duty Cycle	T
f_s	Switching Frequency	Hz

Chapter 1

1. Introduction

1.1 Background and Motivation

Concerns about global warming and climate change have been increasing for the past several years, with scientists and environmental proponents giving frequent warnings on their potential impacts. These global issues are becoming important to the agendas of politicians, especially in developed countries, where awareness of the consequences of global warming is becoming more widespread. Politicians and activists are attempting to set new regulations and standards to control the dangers posed by global warming to the global community. On the other hand, demands for fossil fuels are rising with the rapid economic growth of developing countries. The rapid increase in fossil fuel prices will have destructive short and long-term impacts on the national economies and security of developed countries. Buildings present one of the best opportunities to reduce energy consumption and limit Greenhouse Gases (GHGs). Restructuring building designs, construction and operation processes based on design performance will reduce how buildings use energy and other resources [1]. The design and analysis of Net Zero Energy Buildings (NZEB) are challenging problems of increasing significance. The NZEB objective has raised the bar of building performance and will change the way buildings are designed and constructed. During the coming years, the building design community at large will be galvanized by mandatory codes and standards that aim to achieve neutral or zero energy built environments (ASHRAE 2008; EU 2009; IEA 2008) [2].

Most self-built low energy houses are (one-offs), and the recommended designs require specific analysis to forecast their future energy, performance, which is highly dependent on their

design and location. Building simulation can provide reference for this performance and can be used to assess different design options for optimization. This research assesses design options for a self-built low energy house in Libya and its power system, efficiency and cost effectiveness using the BEopt simulation tool as well as other software [2].

Today, more and more building owners are looking to have their existing or new building made more energy efficient or "green labeled", a term synonymous with clean energy and being environmentally friendly. Whether driven by financial or environmental reasons, the green movement is driving building designers and engineers to develop increasingly more inventive methods to save energy in buildings. New materials, techniques, technologies, and computer modeling programs have helped energy efficient buildings come to life. However, despite the gains in lower energy use and improved building quality, the question all building owners ask about new technologies is "What will it cost?" Passive houses allow for space heating and cooling related energy savings of up to 90% compared to typical and traditional building stock and more than 75% compared to average new buildings. They use less than 1.5 L of oil or 105 m³ of gas to heat 1m² of living space per year. Great energy savings have been demonstrated in warm climates where typical buildings also require active cooling [3].

Most studies have indicated that passive house standards can be implemented all over the world for any climate. The general approach is the same, but the properties of individual components vary. In warmer climates, for instance, specific attention should be paid to passive cooling measures, such as shading and window ventilation, to ensure comfort throughout the hot months. In addition, the individual characteristics of any passive building should be optimized to the local conditions or cases [4].

There are numerous papers which outline how the total energy demand of a building is fully controlled by electricity demand, and consequently in the NZEB definition only electricity is considered. One of the reasons for this condition is simply the shortage of district cooling in many countries; however, this issue is not commonly mentioned in the definition, which makes it inaccurate. An example can be displayed by the NZEB definition given by Gilijamse [4]. “A zero-energy house is defined as a house in which no fossil fuels are consumed, and the annual electricity consumption equals annual electricity production”. Unlike the self-sufficiency situation, the electricity grid acts as a virtual buffer with annually balanced deliveries and returns [4]. Zero energy home is the term used for a home that optimally unites commercially available renewable energy technology with state-of-the-art energy efficiency construction techniques. In a zero-energy home, no fossil fuels are consumed and its annual electricity consumption equals its annual electricity production. A zero-energy home may or may not be grid connected. Without the various energy efficiency policies, which have been in effect since 1973, worldwide energy consumption would be 56% percent higher today. The net-zero energy initiative offers an inclusive solution to the current environmental challenges facing commercial and residential buildings. On-grid nets zero energy homes produce renewable energy on-site at an amount equal to, or greater than, the building's total annual energy consumption. The net portion means the building may use energy from a utility grid (electricity and/or natural gas) during certain times of the day (or night time) but supplies renewable energy back to the grid during other times. This balance equals out over the course of a year [5].

1.2 Net-Zero Energy Buildings - Definitions

There are several definitions of a ZEB, and each definition differs depending on the boundary and metric used to define the building. A net ZEB is, ideally, a building that through

high efficiency gains can meet the rest of its energy needs through renewable technologies. In fact, a ZEB is not only zero energy, it is a building that no longer consumes energy but rather produces it. At the zero point, the sum of the energy flow in equals the sum of the energy flow out. There are four definitions used for ZEBs: net-zero source energy building, net-zero site energy building, net-zero energy cost building, net-zero energy emissions buildings, and off-the-grid.

“Net zero site energy” is the amount of energy provided by on-site renewable energy sources, which is at least equal to the amount of energy used by the building. “Net zero source energy” generates the same amount of energy as is used, including the energy used to transport the energy to the building. “Net zero energy emissions” are carbon emissions generated from fossil fuel used to balance the amount of onsite renewable energy production. “Net zero energy cost” is the cost of purchasing energy balanced by income from sales of electricity generated on-site to the grid. “Off-the-grid” is stand-alone ZEBs that are not connected to an off-site energy utility facility. They require distributed renewable energy generation and energy storage capabilities.

Passive House is an expression used in the last ten years to indicate a standard for energy efficiency in buildings. It leads in ultra-low energy buildings that require little energy for space heating or cooling. A Passive System also provides indoor environments with heat, cold, ventilation or light by using and controlling the natural energy flows which surround a building, such as solar radiation and wind [5].

There are several advanced sustainable building design standards such as Eco-homes (BRE, UK), PassivHaus (Germany), AECB (UK), PassivHaus (Qatar), and LEED (USA). These

standards provide different ranking criteria to evaluate energy efficiency and/or zero energy buildings. However, there are no specific strategies or design guidelines provided for achieving zero energy building designs. Specific design guidelines and strategies are extremely important for architects or engineers to popularize zero energy buildings. The purpose of this study is to investigate the feasibility of a zero-energy house design for Libya, and provide specific design methods to achieve a zero-energy house design for Libya and its power system.

1.3 Net-Zero Energy Houses – Examples

Air conditioning accounts for more than 60% of the electricity consumption in Gulf Cooperation Council (GCC) countries. Consequently, a global sustainability assessment system (GSAS) restricts the maximum annual cooling demand for new build housing difference in Qatar to 121 kW h/m^2 [add references here]. High rated energy efficient houses must use 72 kWh/m^2 or less. GSAS goals have increased the need to devise passive design technologies to minimize the cooling demand in hot, humid climates. A prototype house was constructed to test new technologies and variant insulation techniques, such as dynamic insulation. The house has two operation modes, the static manner and the active manner [6]. This approach must be considered and followed to achieve the aspirational goal of net-zero energy buildings or passive houses.

There are some digital pictures/ renderings below that show what the passive houses look like. There are very few Passive Houses that have been built in the Middle East recently, and this was the first Passive House project built in 2013 in Qatar. Also, Qatar is located on the Arabian Peninsula and is known for its very hot and humid climate. Moreover, the average dry bulb high temperature is 105° F (40° C) with a moisture point temperature of 80° F (24.7° C). Many days throughout the year exceed these points. In addition, the weather conditions are reversed from

those in Europe, where the passive house concept developed. The main goal of this research is to provide a demonstration project compared to a standard Qatar villa, to promote the creation of more sustainable homes. The project consists of two single-family villas, which were designed for two similar families with two young children. One of those houses has a total area of 2153ft² (200 m²) and was designed and built based on the Passivhaus guidelines and standard, as shown in Figures 1.2 and 1.3.

Source: Qatar Foundation, 2013



Fig. 1.1. Concrete passive house in a hot climate

The predictable annual energy use intensity (EUI) for the house is 11.1kWh/ft²/yr. \approx (120kWh/yr-m²). The roof is constructed with 14.5 inches \approx (370mm) of polystyrene to ensure the super insulated and airtight envelope. The windows also have had triple panel glazing to reduce solar heat gain through the windows. In addition, to minimize the air infiltration, a mechanical ventilation system with energy recovery is used to provide fresh air.

Source: Qatar Foundation, 2013



Fig. 1.2. Concrete passive house for two families in Qatar

Source: Qatar Foundation, 2013



Fig. 1.3. Concrete passive house in Qatar

As indicated in figures 1.2 and 1.3, the architectural design of two villas and the passive house is visible with the photovoltaic coating the roof. In addition, some techniques such as

shading are used to protect the window space from the sun's heat, which can cause overheating indoors.

Source <http://inhabitat.com/four-houses-project>



Fig. 1.4. Concrete passive house built in Saudi Arabia

Fig 1.4 above shows one of four houses built in Judah, Saudi Arabia, which is in the Middle East and has rash weather, especially in summer. According to Dom Architectural, the goals of designing and building the four houses were to achieve net-zero energy houses by using the new technologies such as shade plants, sunlight orientation and solar panels to be used for generating the power and creating a green environment. These houses have been built and designed in the correct ways for achieving these main goals. Also, the space of the house is painted with a simple white color to minimize solar radiation that hits the top floor of the house. This idea has also become a point of interest in many countries in the Middle East.

Source: <https://greenhomeinstitute.org/greenstar/>



Fig. 1.5 Passive house in Minnesota, US using sustainable elements

Fig. 1.5 shows a passive house in Minnesota, United States. This city has experienced weather-related disasters and the temperature exceeds 90⁰ F on some days and it has high humidity that causes pollution which contributes to putrefactive air. As a result, it began to look for a better way to reduce the consumption of energy, leading to lower CO₂ emissions. Minnesota has an increasing number of passive houses that help in the creation of a green environment using a renewable energy system. Moreover, passive houses have begun to become more common in the United States. The table below shows some examples of passive houses in different countries with almost the same climate.

Table 1.1 Zero Energy House List in Hot, Humid Climates.

Housing Name	Housing Type	Floor Area(ft ²)	Annual Energy Used kWh/yr-ft ² or m ²	Total Project Cost
New York City,951 Pacific Street Brooklyn	Passive House	1,500-ft ²	12.5 kWh/yr-ft ²	-----
Savoy House Savoy, Massachusetts	Single-family home	2,000-ft ²	6.5 kWh/yr-ft ²	-----
Qatar Green Building	Passive House	2,153-ft ²	120 kWh/yr-ft ²	-----
Margate, New Jersey	Single-family house	2,600-ft ²	9 kWh/yr-ft ²	-----
Cottles passive home	Single-family house	3,170 ft ²	11,100kWh/yr-ft ²	\$450,000
Rancher using passive house	Single-family house	1560 ft ²	106.47kWh/yr-m ²	\$430,000
Minnesota Green-Star	Passive House	2,597 ft ²	102 kWh/yr-m ²	\$345,00

Source: Net-zero energy buildings and passive house + Renewables (Flip book) [7].

1.4 Barriers to Net-Zero Energy Buildings in Libya

Even if the strategies and technologies needed to build more energy efficient buildings exist, the question is, why are all the buildings in the country not moving toward net-zero? The flaw may be in the traditional way of designing buildings as well as understanding the higher costs associated with green buildings. Numerous building designers still design their respective systems individually without considering how much their system impacts other building systems. In the traditional building design process, the architectural team works with the owner to construct a building program that specifies the needs of the building. The architect designs the building to satisfy the program requirements, and then the project engineers design the electrical and mechanical systems and evaluate compliance with energy codes and acceptable levels of environmental comfort. However, because many important architectural decisions are set at this point, few changes can be made that will improve energy performance [8].

In contrast to the conventional building process, the entire-building design process requires the best team, architects, engineers (electrical, and mechanical), energy and other consultants to work together to understand the energy performance goals. The whole design team focuses from the beginning on energy and energy cost savings. The process also depends heavily on energy simulation. To be active, the process must persist through design, construction, and affordability [9].

The purpose of this study is to analyze the design and economic benefits of a net-zero houses in the hot and humid climate of Libya. Hot and humid climates are cooling controlled and require stationary cooling and dehumidification to maintain a comfortable 20⁰C indoor environment and result in higher cooling energy costs. Different building designs will be

explored to reduce the energy consumption of the building. The final design solution, however, is proposed not to be the optimal solution, as there are many variations of the design that could achieve the same effect. The economic analysis will only be limited to construction costs and energy costs. Net-zero energy buildings produce as much energy on-site as they consume annually. Many technologies are needed to reach this target, such as high efficiency heating, ventilation, and air-conditioning (HVAC) systems that are already affordably available. In the meantime, products such as triple-glazed windows and solar panel insulations are not very cost-effective for owners compared to more traditional alternatives, researchers observed. Therefore, only a handful of NZEBs have been constructed. Interest, however, is growing in these concepts [9].

There are some digital pictures below that show what the passive houses look like. Each passive house has a different shape from the other as well as a different design. When designing a house, successful strategies should be followed to achieve the main points of a net-zero energy house; for example, the orientation of the building, shading windows, the shape and use of proper materials such as thermal mass for the exterior walls, floors and roofs. Figure 1.5 indicates that the house is built using concrete. As indicated in the photo, the house is supplied by some models of solar panels for generating free power from the sun that shines on the solar panels to feed the house electricity and this free energy source helps to minimize CO₂ emissions and keep the environment clean. The Figure 1.6 below shows what the renewable energy system looks like. In addition, the largest resources around the world are used: sun energy and wind energy.

Source (<http://www.eastwatt.com/>)

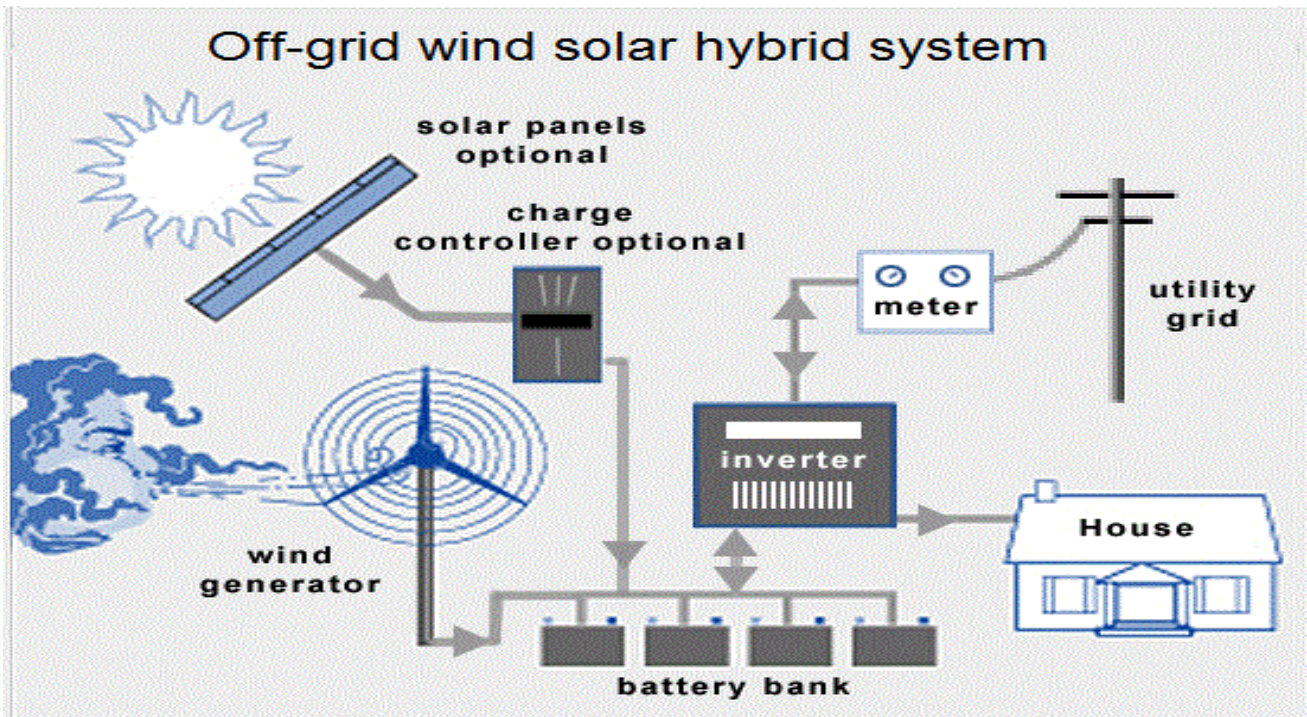

Fig. 1.6 Diagram of the hybrid system used to power the house

Fig 1.6 above shows a hybrid power system known as off-grid solar with wind turbine and battery storage generates power in the same way as a typical grid-connected solar system. Moreover, this system can store the solar energy generated. The battery system is an assistance factor when failures to the grid occur. A hybrid system enables consumers to store the solar energy generated within a battery bank, which gives them the ability to use it for their home during the evening, especially when the cost of electricity is typically at the peak rate [10].



Fig. 1.7: Concrete passive house in a hot climate



Fig. 1.8: Concrete passive house in a hot climate



Fig. 1.9. Concrete passive house in Qatar



Fig. 1.10 Concrete passive house in Qatar

All four shapes of the houses above illustrate that they have been built as net-zero energy buildings, which means they can achieve the optimum performance of the energy used. If awareness and understanding of climate change continue to increase, researchers and some others who are interested in this issue and the excessive energy consumption caused by buildings will continue to build these kinds of houses that help in the reduction of CO₂ emissions, energy consumption and ensuring thermal comfort.



Fig. 1.11 Concrete Passive Solar House in a hot climate

As seen in Figure 1.11 above, the passive solar design is one of the most important strategies available for energy efficient construction and greenhouse. At the same time, the sun provides free heat such as day-lighting, and the best connection to the outdoor environment, and it does this for the life of the construction as well. In this design, some of interior thermal mass was used to maintain a comfortable indoor environment. Moreover, other strategies were used for that house such as using plenty of south-facing glazing, and one way to lower costs is to

specify as many fixed windows as possible. This passive solar home was designed during spring season in Asheville, North Carolina [10].

1.5 Literature Review

1.5.1 Energy Consumption in Buildings

According to the IEA (International Energy Agency, 2014), buildings represent 32% of total eventual energy consumption and a significant source of carbon dioxide (CO₂) emissions. In terms of primary energy consumption, buildings represent about 40% in most IEA countries and, therefore, a more sustainable future begins with low energy buildings that must combine comfort and function using passive systems and new variable technologies. The benefits of highly energy efficient houses include: fuel bill reduction, more comfortable indoor environments, effect reduction of the built environment and the best use of obtainable energy sources (Zero Carbon Hub, 2014) (ZCH) [11].

1.5.2 Houses Energy Consumption Survey in Libya

The General Electrical Company of Libya reported that an electric power generation and transmission system was unable to meet the sharp and growing demand for electricity due to the high heat summer of 2013 and cooling energy demand. This company detailed the energy situation of Libya, reporting on 11/7/2015 that the consumption of energy was around 22.035 Giga watts (GW) by all sectors and the amount consumed by residential buildings was 5,365 Giga watts (24%) of the total amount. The problem in this situation is that energy prices are heavily subsidized in all economic sectors in Libya by government, and it is difficult to promote renewable energy and energy efficiency on a cost-effective basis. Furthermore, per a World

Bank estimate, 99.8% of the Libyan people have access to electricity, which is the highest rate among African countries. Even though Libya has the biggest area of land in North Africa, there are not any renewable devices installed to generate electricity to minimize energy consumption from the General Electrical Company [12].

1.5.3 Design for Climate

Design for climate requires that homes be designed or modified to ensure that the residents remain thermally comfortable with minimal auxiliary heating or cooling in the climate where they are built. Passive design works with the climate, not against it. This is an important component, as are energy efficient heating and cooling systems, and the behavior of the occupants. Approximately 40% of household energy is used for heating and cooling to achieve thermal comfort. This rate could likely be cut to zero in new housing through sound climate responsive design and indeed this should be our goal. In addition, considering current consumer preferences and industry practices, halving the rate to 20% is highly achievable in the short term. The 40% of household energy used for heating and cooling to achieve thermal comfort can be reduced. Reducing or eliminating heating and cooling needs in existing homes is a significant challenge; particularly for those designed and built before building energy efficiency standards were introduced, when appliances were effective but inefficient. Based on 1.5% annual renewal rates, at least 50% of our current housing stock will still be in service in 30 years' time.

1.5.4 Libya's Climate, Average Weather, Temperatures, Rainfall, Sunshine, Humidity, Graphs

This research studies the case of net-zero energy houses and their power system for Libya. Libya is located on the Cancer Orbit line and is exposed to the sun's rays throughout the year

with long hours during the day. It is also on a flat plane on the coast. Essentially, Libya has two different types of climate, one of them being semi-arid and the other desert. The semi-arid climate only gets 16 inches of precipitation per year. It has also hot summers and cold winters. Usually, the desert climates receive less than 10 inches of rainfall per year. Their humidity is low and with high temperatures and at night the temperature rises. Also, the deserts have many sand dunes. However, for three months the climate is quite moderate. For example, March, April, May, June, July, and August have the highest temperatures but low precipitation. January, February and December have the highest precipitation but low temperatures. The winters are cold and summers are very hot [13].



Fig. 1.12 The Map Shows Libya Located Near the Tropic

Examining the landmass above we see 1.6% has a semi-arid climate (BS), 97.2% has an arid desert climate (BW), and 1.2% has a temperate meso-thermal climate with dry summers (Cs). Of the population, 20.7% live in a semi-arid/steppe climate (BS), 47% live in an arid/desert climate (BW), and 32.3% live in a temperate/meso-thermal climate with dry summers (Cs).

Table 2.1 below indicates the information on the climate of some Libyan cities

Table1.2 Information on the Climate of some Libyan Cities

Location	Latitude	Longitude	Alt.m(ft)	Climate	Biome	Average Tem (C ⁰ , F ⁰)	Precipitation Mm(inch)
Tripoli	32 ⁰ 40'N	13 ⁰ 9'E	81(266)	BSh	Subtropical desert scrub	20(69)	251(10)
Misratah	32 ⁰ 19'N	15 ⁰ 3'E	32(105)	BSh	Subtropical desert scrub	21(69)	249(10)
Benghazi	32 ⁰ 5'N	20 ⁰ 16'E	132(433)	BSh	Subtropical thorn woodland	20(67)	258(10)
Tobruk	31 ⁰ 51'N	23 ⁰ 55'E	156(512)	BWh	Subtropical desert	19(66)	95(4)
Hun	29 ⁰ 8'N	15 ⁰ 56'E	207(679)	BWh	Subtropical desert	21(69)	35(1)
Kufra	24 ⁰ 13'N	23 ⁰ 18'E	435(1427)	BWh	Subtropical desert	23(73)	1(0)
Libya Average 30 ⁰ 22'N--18 ⁰ 36'E 14 ⁰ 7(570)			174(570)	BSh	Subtropical desert	21(69)	148(6)

Source: www.climate and weather in Libya

All graphs on the next page illustrate the climate in Libya; it borders the Mediterranean on the coastal strip, and has a desert climate in the interior. At the same time, the temperatures are typical of the Mediterranean climate and rain is scarce on the coast, so that desert is found even in a part of the coast. The precipitation amount usually goes from 400 to 700 mm per year [14].

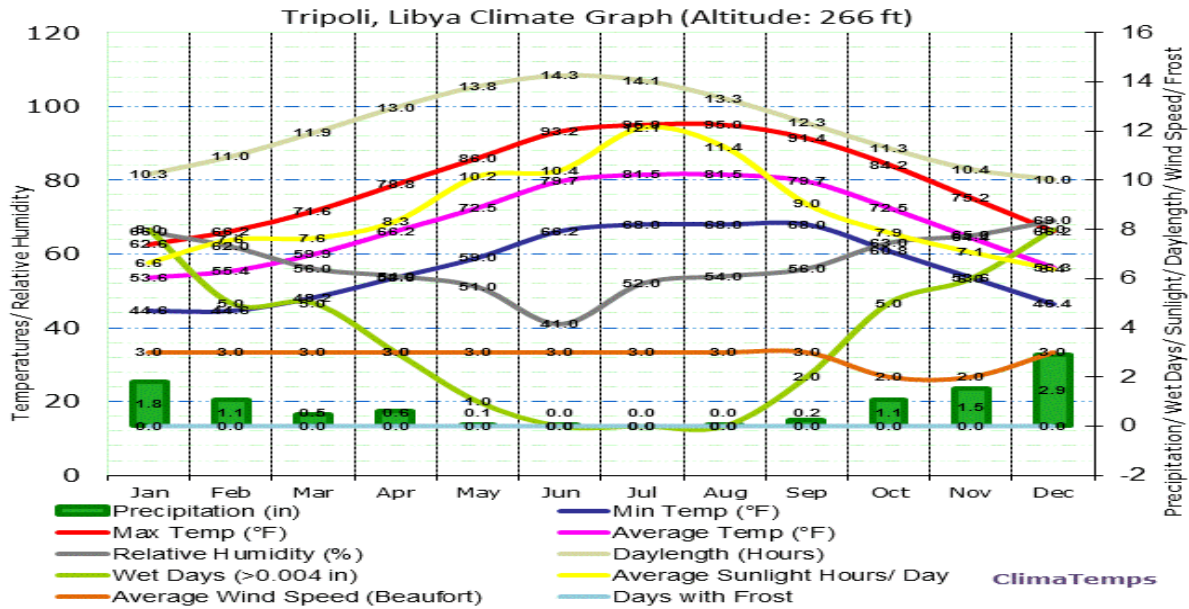

Fig. 1.13 Graph Indicates the Climate in Tripoli City - Libya

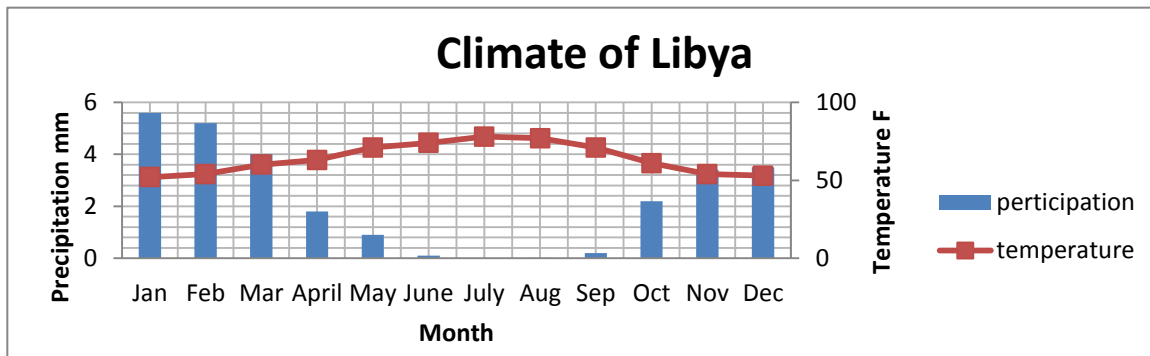

Fig. 1.14 Annual Temperature and Precipitation

Libya has an average daily solar radiation rate of about 7.1kWh/m²/day in the north regions and around 8.1kWh/m²/day in the south regions. Therefore, this type of climate should take advantage of the use of power generation because it is one of the natural resources that contribute to the reduction of CO₂ and energy consumption demand as well achieving the required goal of net-zero energy buildings.

1.6 Motivation

In many countries, there are numerous examples of NEZB with excellent results. Why then are these types of constructions not seen much in warm areas of North Africa such as Libya? How could this knowledge become widespread and used in those countries in hot climates? This study will address these questions to see if NZEB can be applied in those areas. In fact, the reason for choosing this topic is not only because of curiosity, but also because in the future I would like to extend my studies to the field of energy efficiency. Therefore, I believe this preliminary study will allow me to know much more about this issue.

1.7 Feasibility and Case Studies

1.7.1 Feasibility

The National Renewable Energy Laboratory (NREL) studied the technical feasibility of commercial ZEBs. The main question determined by the study was to what scope a photovoltaic system can provide for a building's energy needs. Based on Energy Plus simulations of various buildings and existing and projected technologies to 2025, the study found that 62% of buildings could reach net zero (Griffith, 2007). Concurrently, 47% of building floor space could achieve net zero. The study also found, assuming the exportation of surplus electricity from PV systems,

new buildings could, on average, consume only 12.2 BTU/ft² (British thermal unit) which was an 86% reduction from the current stock. Office buildings, when compared to the ASHRAE Standard 90.1-2004, required 67% in energy savings to reach the ZEB goal. Also, wind energy is used to generate electricity for all types of buildings. Hence, we could make hybrid system to cover demand energy with zero emissions and reduce energy consumption. By using these modern technologies and renewable sources the target of NZEB can be achieved.

A sector analysis displayed that office buildings have a below average chance for achieving net zero, due largely in part to high plug and process loads and building height. Standing 19 individual technologies ability to reach the ZEB goal, the potential to reduce net-site (EUI) Energy Use Intensity was highest for thermal insulation, followed by lighting, plug and process loads, HVAC, dynamic windows, day-lighting, and passive solar. The assessment concluded that achieving a ZEB goal was more achievable than generally assumed.

1.7.2 Case Studies

In the Middle East region, there are few passive houses because most of these projects have been done in cold climates such as European countries and American states. In recent years, the idea has become somewhat more widespread, particularly in countries that utilize modern technologies and are working in different climates from the sophisticated countries. This study aim is for the strategy to take into consideration and focus on the residential sector, because it represents most power consumption in the country. Building more high performance houses in Libya will decrease the consumption of fuel and related CO₂ emissions [14].

1.8 Construction System

This research has been focused on types of material, such as thermal-mass, that are used to create net-zero energy houses. These materials reduce energy consumption demand due to cooling systems and create a more comfortable environment inside the building.

1.9 Thermal Mass

Early high-mass walls were made of adobe (clay) and stone conventional homes in hot climates usually have thick walls made of stone or sun-dried brick. The daytime temperatures are often above 80 or 85°F and night-time temperatures are usually below 65°F. This method of wall construction incorporates a lot of thermal-mass. At dawn, the wall is cool. When the sun begins to heat the wall during the day it takes a long time for the heat to penetrate the thick wall. At 1:00 in the afternoon, the interior surface of the wall is still cool, and so is the interior of the house. In the evening, just as the sun is setting, the heat has fully penetrated the thick wall. At night, the warm walls begin to cool, giving off some of their heat to the interior, keeping the occupants warm, even if the weather is chilly outdoors. At the same time, the exterior surface of the wall cools, releasing the stored heat to the outdoor air. The next day, the cycle repeats. In these circumstances, the 12-hour time lag between when the sunlight warms the wall and when the wall gives off heat proves very useful [15].

1.10 Thermal Mass is most useful in Hot Climates

The high mass walls or floors for the new houses are usually set on the interior side of the insulation. A high mass wall consists of concrete masonry units (CMUs) insulated on the exterior and interior with a layer of cement on both sides to be all holes closed. At the same time, a high-mass floor might consist of a 4-inch (10cm) thick concrete slab placed on a continuous horizontal layer of rigid foam. Similarly, researchers have found that using high mass for exterior walls leads to less energy being required for air conditioning. According to Alex Wilson, the editor of Environmental Building News, there are two reasons for using proper high mass walls in building houses, which can lower the cooling bills. The first one is that the direction of heat diffusion through the wall reverses during a 24-hour period. When it is hot outdoors and cool indoors, the heat diffuses inward. At night, when the temperature is warmer outdoors compared to indoors, the heat flows outward. This reversal of the direction of the heat flow reduces the overall heat gain during a 24-hour period, because the heat flow reversal permits heat recovery.

Overhangs of the roof are properly designed, and the weather is not cloudy, and south-facing windows will likely get sun from late November until late February [16].

If there are only a few small windows on the south side of the house, there is no reason for the house to overheat, but if the window areas are large then the house will be flooded with much solar gain, which risks overheating. In addition, where the thermal-mass can help is if the sunlight streaming in the south-facing windows strikes a concrete floor or a concrete wall, the concrete will absorb some of the heat, preventing the house from overheating or at least delaying the action.

Here are some regulations to follow for thermal-mass in a passive solar building:

- The area of the thermal-mass should be about three to six times the area of south-facing glazing.
- The maximum thickness of the thermal-mass usually concrete, it should be about 4 inches (10.16 cm). Thicker concrete will not absorb heat quickly enough for the extra thickness to be useful.
- Dark-coloured concrete floors work better than light-coloured floors.
- Concrete floors should be bare, not covered with carpets.

It has been established that high-mass walls tend to shift some of the air conditioning load from the late afternoon to the night-time hours [17].

1.11 International Residential Code for Buildings

According to section N1102.2.4 of the 2009 International Residential Code (IRC) mass walls shall be considered above grade walls of concrete block, insulated concrete form (ICF), masonry cavity, brick, earth block, rammed earth and solid timber. Therefore, if we choose to build a wall out of one of these materials, the code allows us to include less insulation than would be required for a wood-framed wall, even in colder climate zones. For example, wood-framed walls in climate zones need to be insulated to **R20**. The R-value is a measure of resistance to heat flow through a given thickness of materials, but concrete block walls can be insulated to **R13** if at least half of the insulation is on the exterior of the wall.

In a hot climate, to use the thermal mass to help lower air conditioning bills, the thermal-mass should be in exterior walls. In addition, the walls also need plenty of insulation. Although interior concrete sometimes has thermal benefits, it also has drawbacks including its high cost. In

most climates, one can get the same benefits that concrete might provide by simply installing more insulation and in most cases the added insulation will cost less than the concrete [18].

1.12 Specifications for Concrete Masonry Units

There are many kinds of concrete used in buildings, and one of the most common masonry units is the concrete block, which consists of hardened cement and may be completely solid or contain single or multiple hollows. It is made from conventional cement mixed with various types of materials including sand, gravel, crushed stone, expanded shale or clay, volcanic cinders (pozzolan), and pumice. The term "concrete block" was formerly limited to only hollow masonry units made with such aggregates as sand, gravel, and crushed stone. Today, the term covers all types of concrete blocks, both hollow and solid made with any kind of aggregate. Concrete blocks are also available with applied glazed surfaces, various whole designs, and a wide variety of surface textures.

Although concrete blocks are made in many sizes and shapes and in both modular and non-modular dimensions, its most common unit size is $7 \frac{5}{8}$ by $7 \frac{5}{8}$ by $15 \frac{5}{8}$ inches. This size is known as 8 by 8 by 16-inch block nominal size. All concrete blocks must meet certain specifications covering size, type, weight, moisture content, compressive strength, and other characteristics. Properly designed and constructed concrete masonry walls satisfy many building requirements, including fire prevention, safety, durability, economy, appearance, utility, comfort, and acoustics. Typical unit sizes and shapes are shown below. [19].

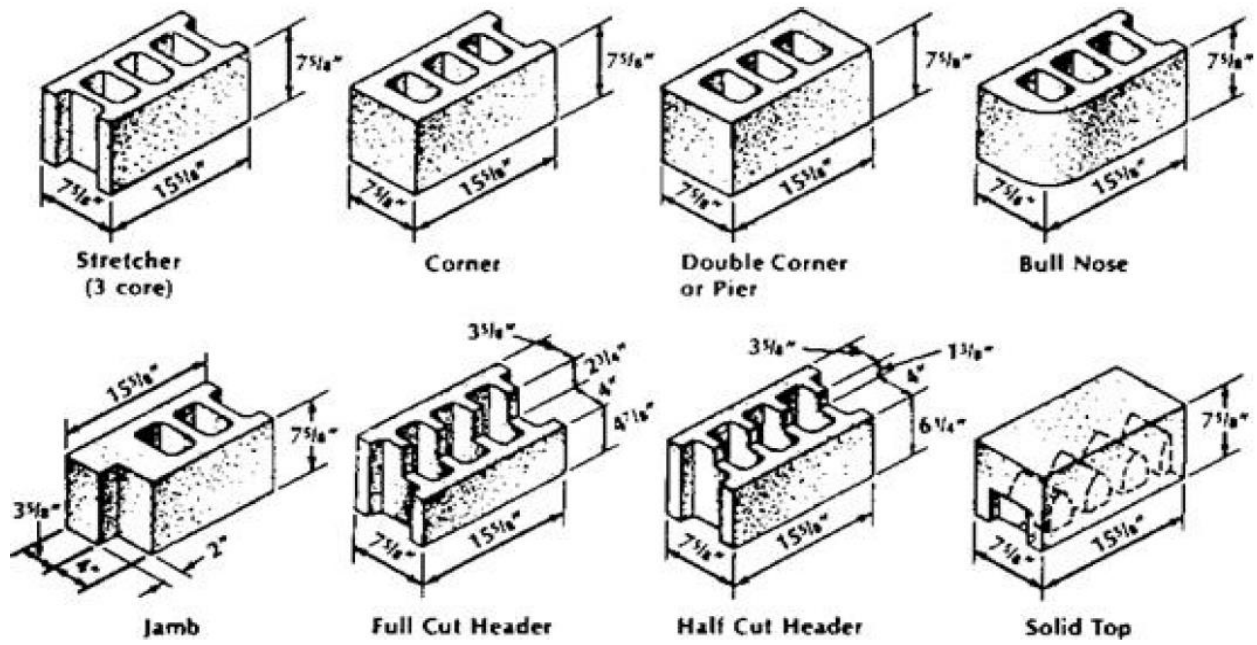

Fig. 1.15 Typical Unit Sizes and Shapes of Concrete Masonry Units [19]

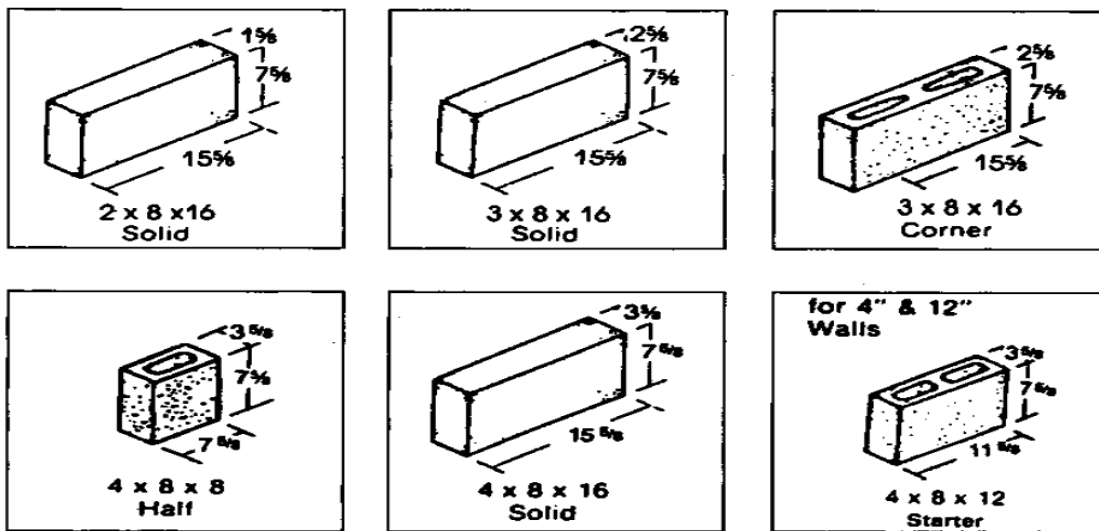

Fig. 1.16 Types of Concrete Used in Libya [19].

Concrete masonry walls should be laid out to make maximum use of full and half-length units as this minimizes the cutting and fitting of units on the job. The length and height of walls, width and height of openings, and wall areas between doors, windows, and corners should be planned to use full size and half size units, which are usually available. This procedure assumes that window and door frames are of modular dimensions that fit modular full and half size units. Then, all horizontal dimensions should be in multiples of nominal full length masonry units. Concrete is extremely useful when building houses that are in harsh climates and aimed to maintain a desired temperature and to protect the houses from rain and snow because all walls built using concrete are strong enough to do so. Moreover, concrete is a thermal mass that leads to the reduction of energy consumption in buildings [20].

1.13 Cooling Homes, Buildings in Hot, Humid Climates

In almost all poorly-designed conventional homes, the causality airspace becomes much hotter than the peak outside air temperature in the summer. This is caused by dark roofs that absorb millions of BTUs of high-summer-sun solar heat gain, a lack of a roof decking radiant barrier system to block radiation from the roof surface into the hot attic, insufficient or nonconductive roof insulation, and there being no way to introduce replacement air that is cooler than outside peak temperature air. The best way to maintain thermal comfort indoors is to consider what good materials to use are. Where summer ground temperatures exceed 19°C at 3 m depth, insulated concrete slabs or insulated elevated lightweight floors with high thermal-mass walls should be used, and earth coupled slabs should be considered in all areas where deep ground temperatures are less than 19°C in summer. In addition, light coloured roof materials should be chosen. In many climates, it is useful to have a lot of thermal-mass inside houses [20].

1.14 Design Criteria and Specifications of the House

The design and analysis of a net-zero energy house located in the hot, humid climate of Tripoli, Libya is performed for this study. A baseline of house energy performance will be established based on the performance rating method established by Appendix G in ASHRAE standard 90.1. The design and construction standard provide standard and technical guidelines for the design of new buildings and renovation projects, ensuring building function quality and sustainability in the social housing sector. These features will lead to the creation of a greener environment and contribute to the reduction of energy consumption in buildings [21].

1.15 Framework and Objective of the Research

The main objective of this dissertation is to determine the practical aspects of the design and analysis of a net-zero energy houses and its power for Libya. Passive design and active design are both involved in the design of modern residences in areas of the Middle East known for high summer temperatures. The introduction chapter gives a summarized overview of the topic, identifies the issues and explains the goals and objectives of the dissertation. The second chapter describes the design of a computer model of a conventional house using two types of software based on the typical house specifications in terms of the structure, materials, thermal mass, and lighting systems used to get results that are as close as possible to the performance of real contemporary houses. At the same time, BEopt software is used for designing the same structure of the house with different values and parameters such as the passive standard to compare the obtained results and to estimate the ordinary house's performance with reliable simulation software to get a general idea about its ability to provide thermal comfort.

Furthermore, the performance of the conventional house model is improved through applying a specific passive standard by inserting the elements and editing parameters pursued by re-simulation the house to evaluate the effectiveness of the improvements. The third chapter will describe a hybrid system that will be installed according to the analysis of energy consumption calculations for that house. The hybrid system consists of sustainable components such as wind turbines, solar panels and some other devices that are also needed. In other words, how a solar design influences the performance of the residential sector in a Middle East region with cold winters and quite hot, dry summers, as well as what is the range of the reduction of energy consumption and CO₂ emissions of the homes? The third chapter explains the configuration of the system for all components and some details for the electrical devices' characteristics inside the system and how they work. The last chapter concludes the results and knowing points from the study. It is predicted that the outcomes will show a very sensible performance of the design and analysis of net-zero energy houses and of the hybrid design that do far better than similar conventional homes. Furthermore, this study will give a reflection and motivation to that area (Middle East). Even though these technologies have recently become available in developed countries, they are still unused in this region because of a lack of awareness, experience and expertise. With these existing resources, we suggest to work hard to understand how we can utilize them for at least small projects and to take the first steps to the next generation.

Chapter 2

2. House design, thermal simulation and analysis in BEopt and Energy 3D

2.1. Introduction

The current chapter focuses on house designing based on thermal simulation and recorded data analysis. Two main software (i.e. BEopt, and energy 3D) are implemented for the best design selection. For optimal software house design selection, a wide range of parameters has been chosen as is required. Such parameters cover house orientation, walls' thickness, windows' shading and face direction, etc. Then, the software outputs various design options with different Energy Consumption Levels (ECL). Selection of the best house design is governed by a combination of both low ECL, which can be determined by data software analysis tools and low construction cost. The ECL can be reduced even more by implementing hybrid power systems, which is covered in chapter three, in which the size determination of hybrid power systems is focused on. The proposed hybrid power systems have three main components, wind, solar panels and battery storage system. The main objective of implementing such a system is to utilize the available free and sustainable energies generated by wind and the sun to reduce environmentally impactful emissions, reduce the use of the high cost grid and to meet the house energy demand. In addition, the results will be presented in the next chapters.

2.2. BEopt Software based on Conventional House Design

This software has several options that help the users to set up all the parameters throughout the designing. The first is the geometry screen. The second is site screen and the third is input screen. Each one of them has different duty and parameters.

2.2.1. Geometry Screen

The house is designed using BEopt software. The direction of the house is east facing and there are three south facing windows to gain the sun's heat during the winter time. The house is one floor and the total area is 1962 ft² (182.3m²). The inputs have been selected per the reality parameters. The windows and walls are created in the new option manager due to the specifications of that house.

2.2.2. Site Screen

This option shows the country that is selected and some information related to the values such as mortgage and this house was without any kind of interest fees.

2.2.3. Input Screen:

Cooling set point: Cooling set point temperature is set to = 95F

Heating set point: None

Natural ventilation: Three days around/week

Mechanical ventilation: None

Humidity set point: None

Water heater: Electric benchmark

Distribution: Un-insulated, trunk-branch, PPR pipe (PEX)

Ceiling fan: Standard efficiency, 5 fans

Wall sheathing: None

2.2.4. Walls

The walls were built using concrete, its R13 and it is common for building in that region to protect the homes from the higher temperature during the summer, and should be higher than the U-value in order to achieve the insulation required as benefits thermal mass in such a climate.

2.2.5. Ceiling/Roofs:

Unfinished attic: Ceiling R7 cellulose, Gr-1. Vented

Roof Material: Tile, light

Radiant barrier: None. The foundation/floor which means the slab is un-insulated and the carpet is 40% used.

2.2.6. Air Flow

Air leakage: 25ACH50 and there is no mechanical ventilation. Natural ventilation is around three days/week. Ensuring a reduction of energy loss and minimizing the moisture damage can help to prevent mold development. The value should be at low levels of air leakage as much as possible.

2.2.7. Windows

Window areas: Project, a new input window to the software. All windows are single glazing with exterior protected wood and the interior shading is (summer=0.5, winter=0.7). The doors are made of high quality wood, and the overhang is also a new input to the software per the areas.

2.2.8. Thermal Mass

Thermal mass is a term that describes the ability of a material to store heating or cooling, something many construction materials can do to a greater or lesser extent. However, to be useful in the built environment it should be able to absorb and release heat at a rate roughly in step with a building's daily heating and cooling cycle. In the first design, the exterior wall mass is none and the partition is Drywall/PCM Mat (Phase Change Material) and the ceiling is the same.

During the summer time, walls and floors with thermal mass will steadily absorb heat at their surface, conducting it internally and storing it until exposed to the cooler air of the environment/night. At this point, heat will begin to displace back to the surface and be released. The concrete and masonry products do this well and, being dense materials, can also store a lot of heat. Therefore, this leads to reducing or eliminating the peak electric power loads in homes, and to maintaining a comfortable temperature range in the home as well. To reach the goal the R-Value and U-value of the buildings should be considered (22) and [23].

2.2.9. Major Appliances:

Refrigerator: Top freezer, EF= 17.6, 95% usage. Selected based on the minimum Electric consumption)

Cooking range: Gas 80% usage

Dish washer: None

Clothes washer: Standard cold only

Clothes dryer: None

Hot water fixture: None

2.2.10. Lighting:

80% CFL (compact fluorescent lamps).

2.2.11. Space Conditioning:

Central air conditioning: There is no central air conditioning, because it requires many devices that are expensive. The air-conditioned rooms are better and do not need high cost maintenance.

A ground-source heat pump is used only for passive houses that are in cold climates and the earth, ground water or other water source is the source of heat in the winter.

Duct: No ducts used

Ceiling fan: Standard efficiency, five fins

Dehumidifier: None

2.2.12. Water Heating:

Water heater: Electric Benchmark

Distribution: Un-insulated, trunk branch, PEX

2.3. R-Value and U-Value Explanation

In construction, the R-value is the measurement of a material's capacity to resist heat flow from one side to the other. In simple terms, R-values measure the effectiveness of insulation and a higher number represents more effective insulation (24). This value also is expressed as the equation below:

$$R = \frac{F^0 * ft^2 * hr}{BTU} = \frac{m^2 * k^0}{w} \quad (2.1)$$

U-value is the coefficient of transmission of heat through the materials which compose the building's "envelope," or outer shell. U-Value has an inverse relationship to R-Value. For

example, a building with materials with an "R" Value of R11 converts to a U-value of 0.09 (1/R or 1/11 = 0.09) (25).

$$U = \frac{1}{R - value} \quad (2.2)$$

A concrete wall has thickness 0.25 m and conductivity 1.7 W/m*k, which are used as default values in the calculator that exists online. The inside and outside surface resistance is estimated to be **5.8** m² K/W. The U-value can be calculated as below:

$$U = 1 / (1 / 5.8 m^2 k / w) + (0.25 m) / (1.7 / m k) = 3.13 w / m^2 k \quad (2.3)$$

2.4. Specifications of the House

This research studies the case of a house in a hot climate for its energy consumption and energy efficiency. The house is fed by renewable, emission-free energy sources such as PV panels and wind turbines, besides using modern technologies such as materials and tools (software), per the international standards and modern technical steps that are followed to reach the desired goal. The total area of the house is 182.3m²(1962ft²) and consists of three main bedrooms, with each bedroom being 4m X 4m; a 4m X 8m living room; three bathrooms and two halls; as well as a guest room for men that is 4m X 5m. The house is built to face north- east. The house has two windows on the north side, as well as the south side are three, and there are two windows on the east side. On the western side, there is a small door. Also, there is a door facing the east and a door facing north. All windows are shaded. The house consumes 7845kWh of energy annually. As has been mentioned, the house is connected to the grid. An air conditioner is

used for the summer time because the temperature usually rises to reach between 33C^0 to 40C^0 ; the air conditioning is suspended from the north side to get some breeze for the motor during the summer time. Furthermore, the house will receive good maintenance soon such as insulation for the roof, walls, and new windows, to become near to a passive house.



Fig.2.1 The Front Façade



Fig.2.2. The South Façade



Fig. 2.3. The Back Façade



Fig. 2.4. The North Façade

Figure 2.3 shows the backside of the house and there is only a small window and door. The purpose is to keep the house protected from the hot wind in the summer time that comes from the west and the massive rain in the winter as well. On the other hand, Figure 2.4 indicates that there are two windows and a main door on the north side to get a small breeze that comes from the north side in the summer time, especially in the evening time. In addition, the breeze comes from the north side, which helps the air conditioning perform better and able to operate. The windows also are shaded to prevent heat radiation from the sun in the summer but in the winter the sun is quite low and there is good material for glazing that allows the radiation from the sun to go inside to create warmth. The main purpose of this design is to achieve the aim of net-zero energy in the house. In near future, solar panels will be installed on the roof of this house to generate electric power and use it to heat the water, meeting the air conditioner's consumption of energy through the summer months as well as when the grid is in failure cases. If the free sources are available, it should be utilized and this approach will achieve a near net-zero energy houses with high performance and energy efficiency and lower costs. In addition, the map of the house shows all the dimensions for each space as shown on the next page.

Figure 2.5 shows the dimensions of the house. Time is a critical matter in the residential design process. The design of a single-family house should take no more than a few weeks to complete. The most sophisticated simulation tools currently available are too complex and time consuming to be used in the residential design process and they require extensive training for users. The analysis of building systems and components will take a lot of time from the designer, and eventually reduce their inclination to support this process.

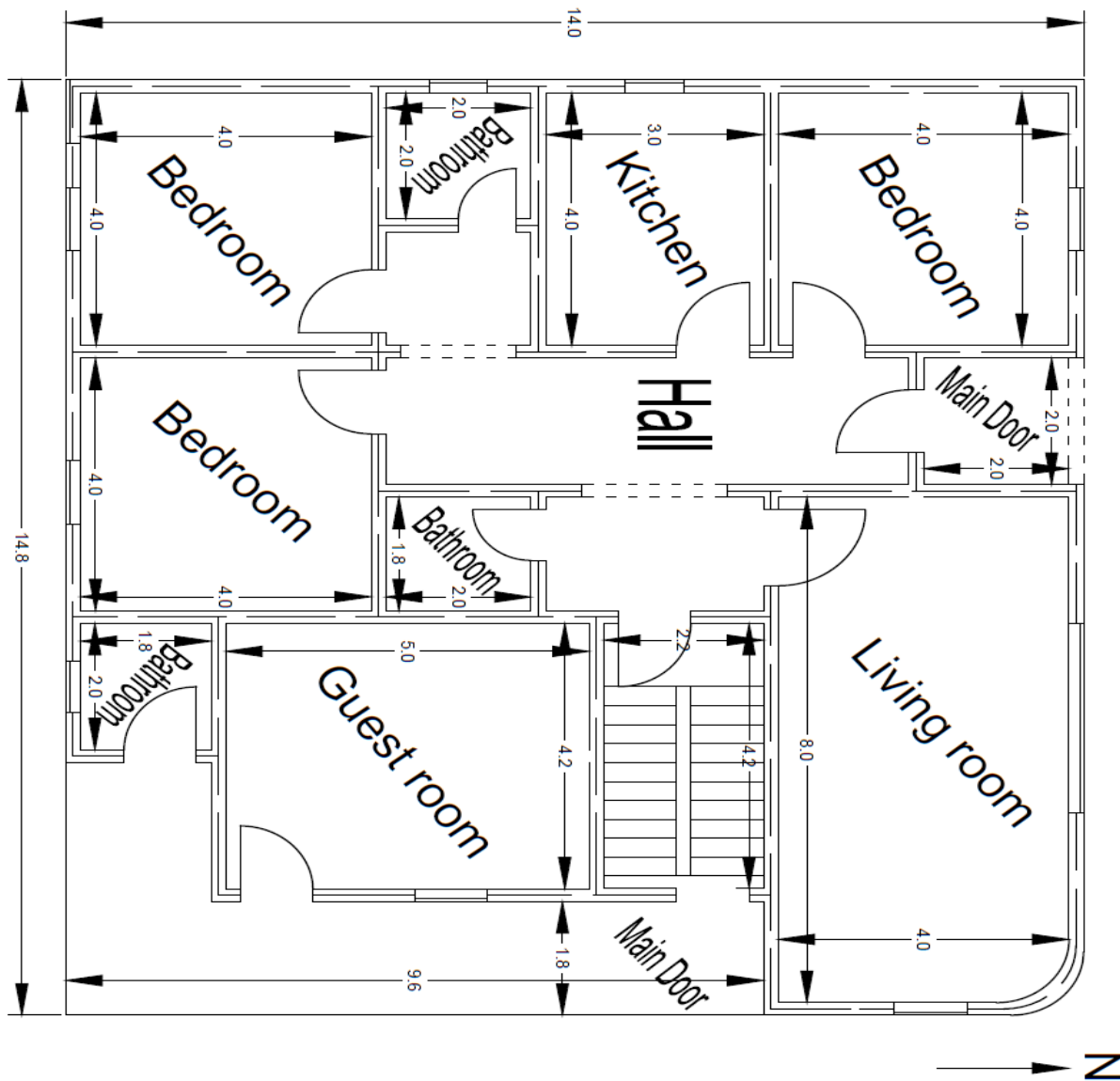

Fig.2.5. Dimensions of the House

2.5. General Passive Design Strategies

There are diverse solutions to provide cooling and heating demands in buildings without utilizing conventional energy supplies such as fossil fuels. Most of these solutions are derived from traditional architecture elements that have been applied for centuries around the world. However, some of the traditional solutions are not feasible anymore regarding the changes that have occurred in urban patterns and lifestyles and then should be improved by innovative solutions. The following passive design strategies are generally used as the methods to improve energy efficiency in homes and to minimize the costs of consuming energy as well as thermal comfort [26].

2.5.1. Typology/Shape

Energy demand in homes is highly impacted by the shape and topology of the home. Building topology and shape are important components in absorption, storage and releasing heat during the day and night, and thus are key factors for the heating and cooling demands in the building. Homes can be categorized as separated houses without any side walls, semi-detached houses with one party wall and terraced houses, which are joined in a row with two or more party walls for each house. To reduce heating and cooling energy demand in buildings some successful strategies should be followed (27).

2.5.2. Orientation

The amount of solar radiation received by a home depends on its orientation. For all topologies in the northern hemisphere, a plan orientation towards the south with a maximum glazing area on the south facade increases solar irradiation gains. Therefore, it reduces the energy

required for heating in winter. The glazed areas can be armed with proper shading in order to block solar gains and the resulting overheating during the summer time.

2.5.3. Shading

It is possible to reduce cooling energy demand in building by using proper shading in summer. Solar shading could be done with devices such as overhangs, awnings and blinds or stone tiles, which should be designed in an effective way to allow solar radiation to reach inside the houses in winter and prevent it in summer. A variety of movable and permanent shading can be utilized. The different solar radiation angles during summer and winter are a critical factor in designing permanent solar devices such as overhangs. This leads to energy saving by reducing cooling demand in summer as well as heating demand in winter. This is as shown below in Fig. 2.12 and this means the sun in winter is quite low and in summer it is quite high (28).

<https://greenpassivesolar.com/passive-solar/building>

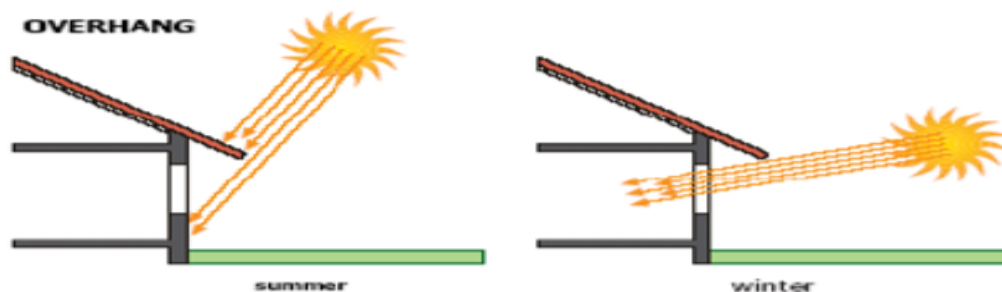

2.6. Function of Overhangs in Summer and Winter

2.5.4. Wall Insulation

The average heat flow through the wall construction can be reduced by wall insulation, which consequently reduces both heating and cooling energy demand in the home. This effect is described by U-value, which refers to the heat flow through one square meter of wall area at a constant temperature difference of 1 K $=$ (1⁰C) per (Passive-On, 2007) [29]. Therefore, the proper insulation of a wall decreases heat losses in winter and contributes to energy saving and thermal comfort. During the summer, thermal insulation reduces the heat transfer from the outside to the inside and thus decreases the cooling demand in a building [30].

2.5.5. Roof Insulation

In summer time, roofs are generally more exposed to solar irradiation than walls due to the different angles of solar beams in winter and summer. Inappropriate roof insulation results in heat transfer from the roof into the building and consequently undesirable hot indoor air during the summer; therefore, roofs should also be insulated by using ceramic with a light color. This figure shows the area of sun radiation in different seasons. In the summer, as temperatures rise, a passive solar building uses its thermal mass to help keep the building cool. For this to happen, the summer sun is kept from reaching the thermal mass of the building. Moreover, a proper designed overhang keeps the heat and energy from being absorbed into the house in the summer. In contrast, the sun in winter is very low, which means the windows have high quality glazing that allows the sun's rays to go inside the house to create thermal comfort. This aspect contributes in the reduction of excessive energy use for the heating demand in the winter and for the cooling in summer [31].

2.6. Design and Energy Analysis of the House

2.6.1. Designing the House

This chapter describes three different design case studies for a Net-Zero Energy House (NZE) in which simulation is used and provides capabilities to evaluate residential building design and for identifying cost-optimal efficiency design packages at diverse levels of whole-house energy savings over the way to NZE.

The design and energy analysis is for a house located in the hot and humid climate of Libya, and was selected and performed for this research. To reach the baseline of the house the energy performance should be established based on the performance rating manner established by Appendix G in ASHRAE Standard 90.1. To reduce the energy consumption of the baseline house, energy efficiency measures were applied to the baseline design. The resulting energy savings were determined from energy modeling analysis with BEopt software DOE- engine. The first design uses BEopt software, and the purpose is to design the house twice. The first case is a conventional house with its real parameters and the second one is a passive house as sash with the standard parameters to achieve the performance of energy consumption in both cases and how much and to what extent energy can be reduced after constructing the house with good materials and new technologies such as in the orientation, windows, proper insulation for the roof and the floor as well as connecting the house to renewable energies systems. By using these techniques, the goals can be achieved. The target of energy saving is between 50% and 75% over the baseline, and energy savings obtained by the proposed package of energy efficiency measures were 54.875 % over the baseline house and the annual energy needs for the house will be met by installing the hybrid system of sustainable elements.

2.6.2. Energy Analysis of the House

Per house bills recorded by the General Electrical Company of Libya, the total electricity consumption for the house was (7845kWh) in the year 2012. The first design uses BEopt software to evaluate the energy loads and the BEopt considers each option and runs the simulation for every selected option. The output mode design shows a result from where the most cost efficient and energy efficient result can be obtained. Figure 2.13 shows that result and the savings on energy consumption. The simulation run shows that the output of energy consumption in the house is less than what the house consumed from the grid.

2.7. House Design Fundamental Using BEopt Software

To design a house using BEopt software, there are many options to set all the parameters for completion of the task. The first option is a geometry screen to design the house, including all dimensions related to the house such as the walls, windows, and the heights. As we see in Figure 3 the design shows one floor and a height of 9 ft. It also shows the orientation of the house. The total area is 1962 ft² (182, 3 m²). There is no garage attached and no basement. The front of the house has an overhang 2m X 10m. This feature is beneficial as shading and it also used as a balcony for sitting in the evenings when the sun is almost behind the house during the summer months. In addition, the windows are all shaded to protect them from the rain during the winter and sun's x-rays during the summer as well.

Geometry Screen of Design

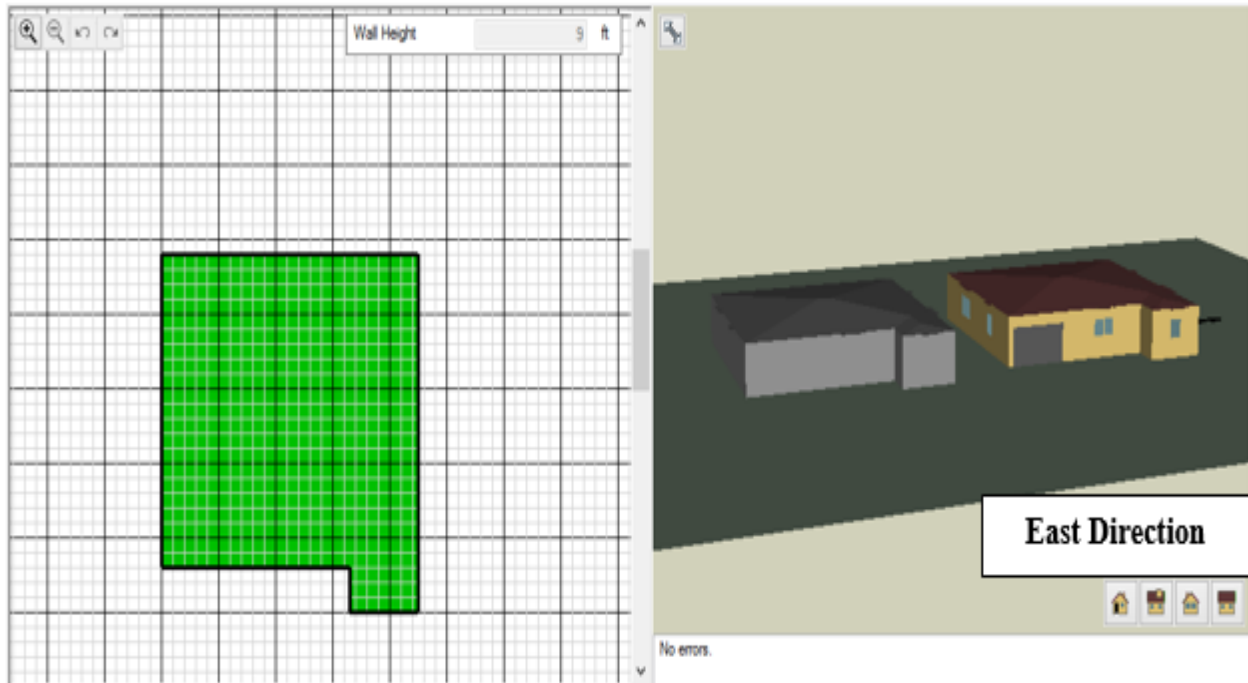

Fig. 2.7 Design House using BEopt Software

This option is a geometry screen that allows the users to design the building, whether it is a new house or building and/or existing building. This is wonderful software and has a certificate from The United States Department of Energy (DOE). It is not difficult to use and is very interesting software. Here in this screen, we draw the building per each area of part of the building and it depends on how many floors you have. Then there is next option to insert the specified parameters for each component. For example, the walls, Roof, Windows, Doors, Floors, everything that has related to the building. It is as shown in the next page in figure 2.8.

Input in Option Screen

Option	Azimuth [degrees]
1) North	180.0
2) NNE	202.5
3) Northeast	225.0
4) ENE	247.5
5) East	270.0
6) ESE	292.5
7) Southeast	315.0
8) SSE	337.5
9) South	0.0
10) SSW	22.5
11) Southwest	45.0
12) WSW	67.5
13) West	90.0
14) WNW	112.5
15) Northwest	135.0
16) NNW	157.5

Fig. 2.8 Shows the Parameters of the House

The figure above illustrates the input parameters for each category as explained below.

a) Site Screen

In the site screen, Libya has been selected, and the materials are set as what exists in the house.

E. BEopt inputs:

Input screen:

b) Operation:

Heating set point is none.

Cooling set point: cooling set point temperature is set to =90⁰ F

Humidity set point: None.

Misc. electric load: 0.30 (the second higher).

Natural ventilation: Three days/wk.

Water heater: Electric Benchmark.

Interior sheathing: Summer = 0.5, winter =0.7

Overhangs: All windows & doors.

2.7.1 Walls: 12-in concrete filled

In Libya, concrete is commonly used for building houses and its compressive strength was usually obtained from test results of a 150-mm standard cube form. According to ACI 2014 criteria. The ranges of the strength (max. strength, min. strength) divided by the average strength are from 34% to 160%.

Wall sheathing: None, Exterior finish: Brick, Medium/Dark, ICF: None

2.7.2 Ceiling/Roofs:

Unfinished attic: Ceiling R-7 Cellulose, Gr. Vented.

Roof Material: Tile, Light, Radiant barrier: None.

2.7.3 Foundation/Floors:

Slab: Un-insulated, Carpet = 40%.

2.7.4 Thermal Mass

Thermal mass is the capability of a material to absorb and to store heat energy when changing the temperature of high density materials such as concrete, bricks and tiles a lot of heat energy is needed.

Floor mass: Concrete, Partition wall Mass: Drywall/PCM Mat, Exterior wall Mass: None,
Ceiling Mass: Drywall/PCM Mat.

2.7.5 Windows & Doors:

All windows are shaded to reduce the sun's rays throughout the summer. The best ways to utilize the power of the sun are the use of proper materials for windows and technologies and the consideration of U-value and R-value to be a higher performance level for achieving the passive house standard. Overhangs are requested for windows and doors.

2.7.6 Air Flow:

Air leakage: 25 ACH50. This value is suitable for hot climate regions and making the house airtight, which means it can also reduce energy loss and avoid moisture damage in the house. Mechanical Ventilation: None.

2.7.7 Major Appliances:

Refrigerator: EF=21.9, top freezer (selected based on the minimum electric consumption).

Cooking range: Gas 80% usage

Dishwasher: None

Clothes washer: Standard, cold only.

Clothes dryer: None.

2.7.8 Lighting:

80% (CFL) compact fluorescent light

2.7.9 Space Conditioning

9.8, 30% Conditioned and standard efficiency, 5 fans

2.7.10 Water Heating:

Water heater: Electric Benchmark.

Distribution: Un-insulated, trunk-branch, PEX.

All parameters set for the conventional concrete house and runs simulation can be shown in the results in the output mode design.

2.8 Output in BEopt Software

The output is shown in Figure 2.9 in the design mode. There is one option per chain selected according to the parameters house, and also the output indicates a 32.9mmbtu/yr. => 0.964 kW average loads annually.

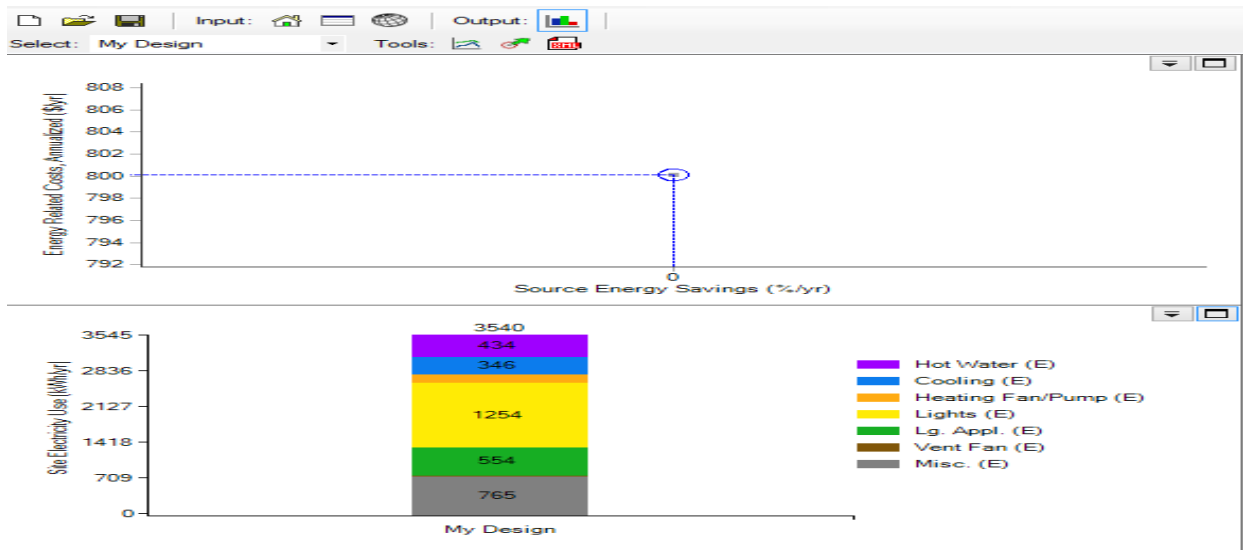

Fig. 2.9. Output in Design Mode

Result in D-View

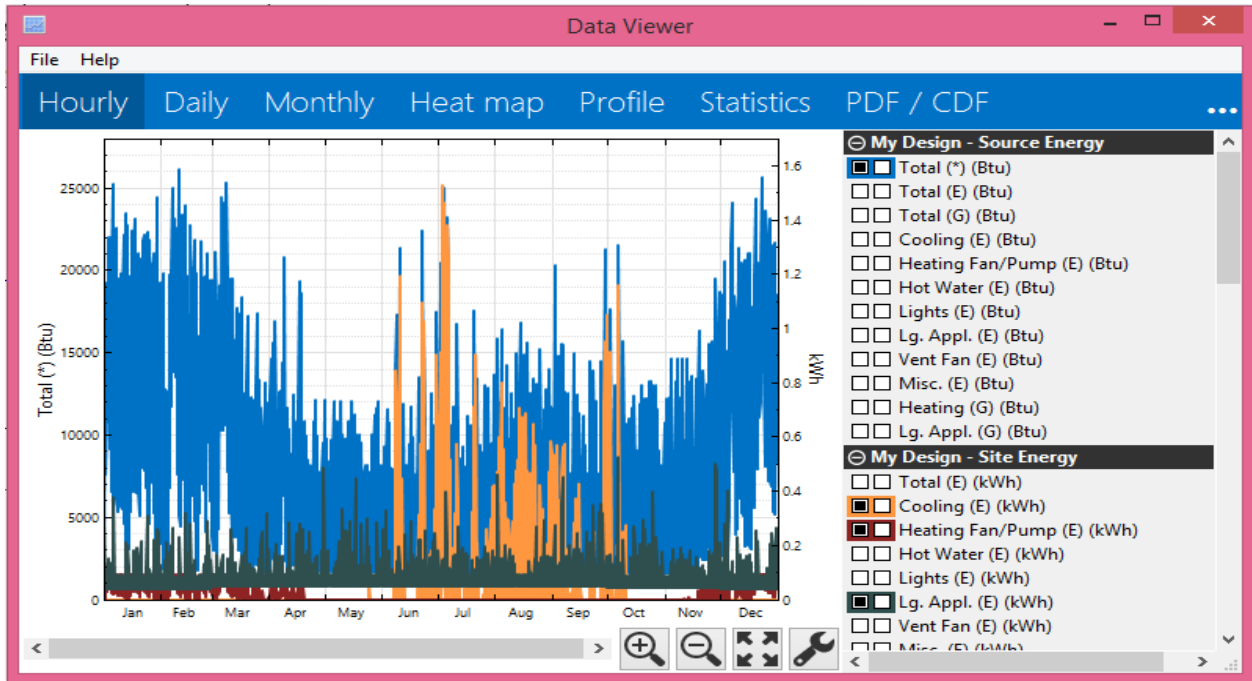

Fig. 2.10. Output in D-View

The figure above shows the hourly load for many devices. For example, the cooling load consumes a lot of electricity, especially between June and July, because during this period the temperature is higher than in any other months. As shown, the cooling demand is around 1.5kWh. The above results can be seen in most devices that consume electricity and their loads such as the cooling demand, heating fan/pump, hot water, and lights.

Monthly profile:

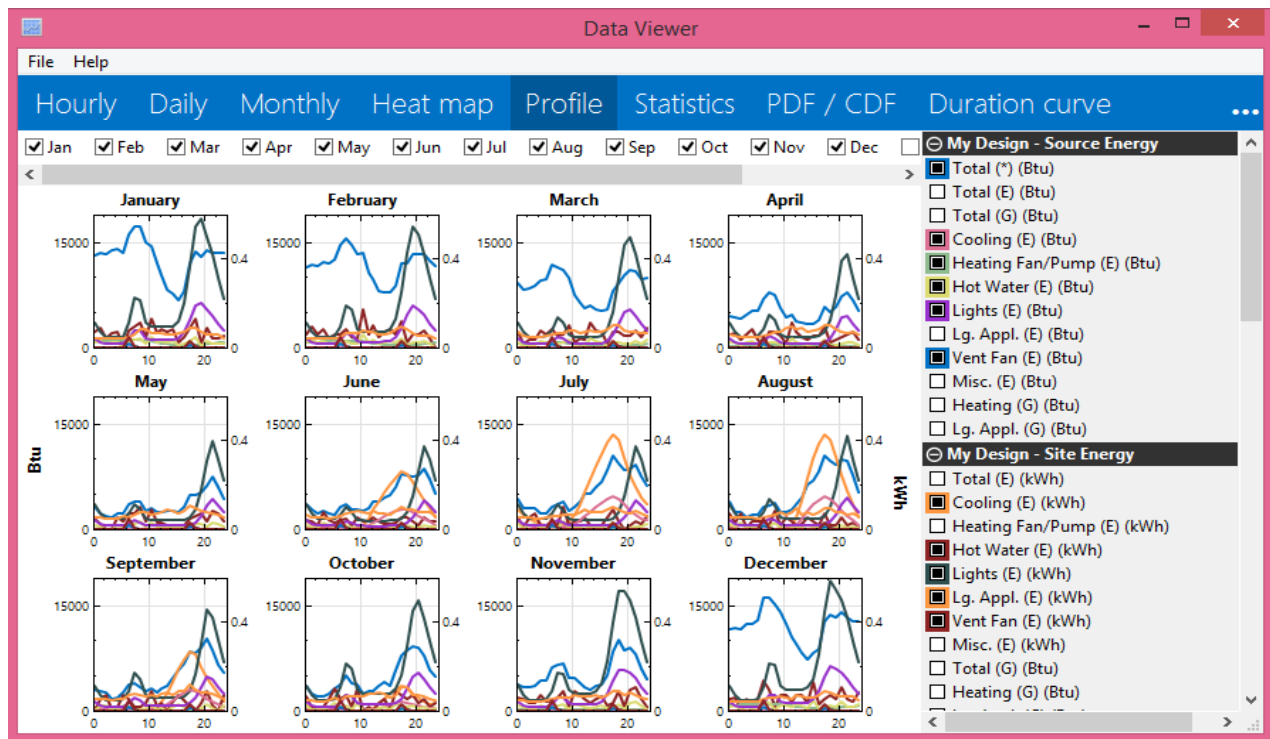

Fig.2.11. Monthly Output

Figure 2.16 shows the monthly profile and the peak loads for each device that consumes energy. Thus, some BEopt simulation results are shown in previous figures.

2.9 Comparison of Measurements and Simulations of Conventional and Passive Concrete House as Sash

The second study is to design the house using a specific standard related to the passive house standard design (Sash) such as the best materials used for this purpose, and several improvements are put to the test to quantify their impact. Some guidelines for simulating passive houses are formulated, then the two cases are compared and the results are presented from the

runs simulations. The purpose of this test is to determine the energy consumption saved in the house generally and thermal indoor comfort. This design essentially uses the same software that was used in the first design.

2.10 Design a Concrete Passive House (Sash)

BEopt software was used to design the house as passive standard (sash) to investigate how much energy and money can be saved compared to the traditional house construction. This design focuses on the proper materials that can be used for reflecting energy performance to minimize the cooling energy demand and the heating loads that come from hot water and small heaters through the winter time into maximum two months. The figure below shows the design of the house and its direction, area and the whole building. In the site screen, Libya has been selected. The house is East facing.

Output Simulation Results in BEopt

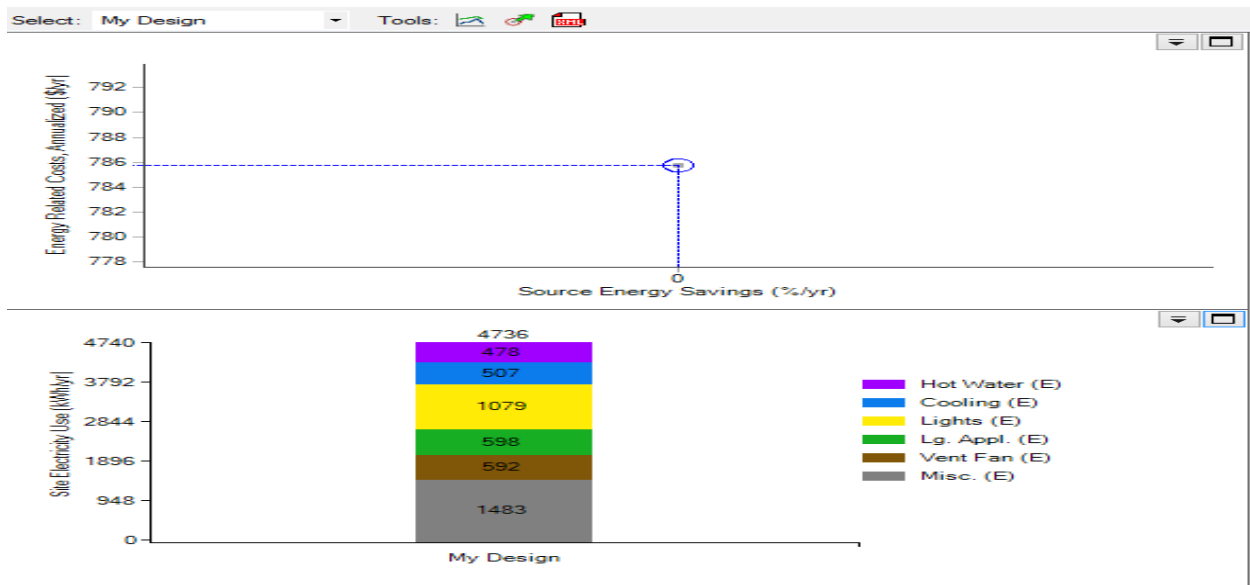

Fig. 2.12. Shows Result Simulation of House as Sash

Here the same design of the house is shown using the same software with different parameters and inputs, which means the design is used for the analysis of energy consumption and energy performance throughout the simulation runs. In other words, some proper materials and perfect insulation are considered for achieving the goal of net zero energy houses or to be close to zero as long as some renewable sources will be used. Figure 2.16 refers to parameters that are selected to be as a passive standard and the results also show the impacts of the runs.

The output can be seen in design mode or optimization mode. Design mode: In Design mode one option per category is selected per the passive house standard and here the output shows 4736kWh/year = >1.63e7Btu/year average loads for the whole year. Some BEopt simulation results are shown in Figure 2.16 and other results are shown in the D-view mode.

Daily Output in D-View

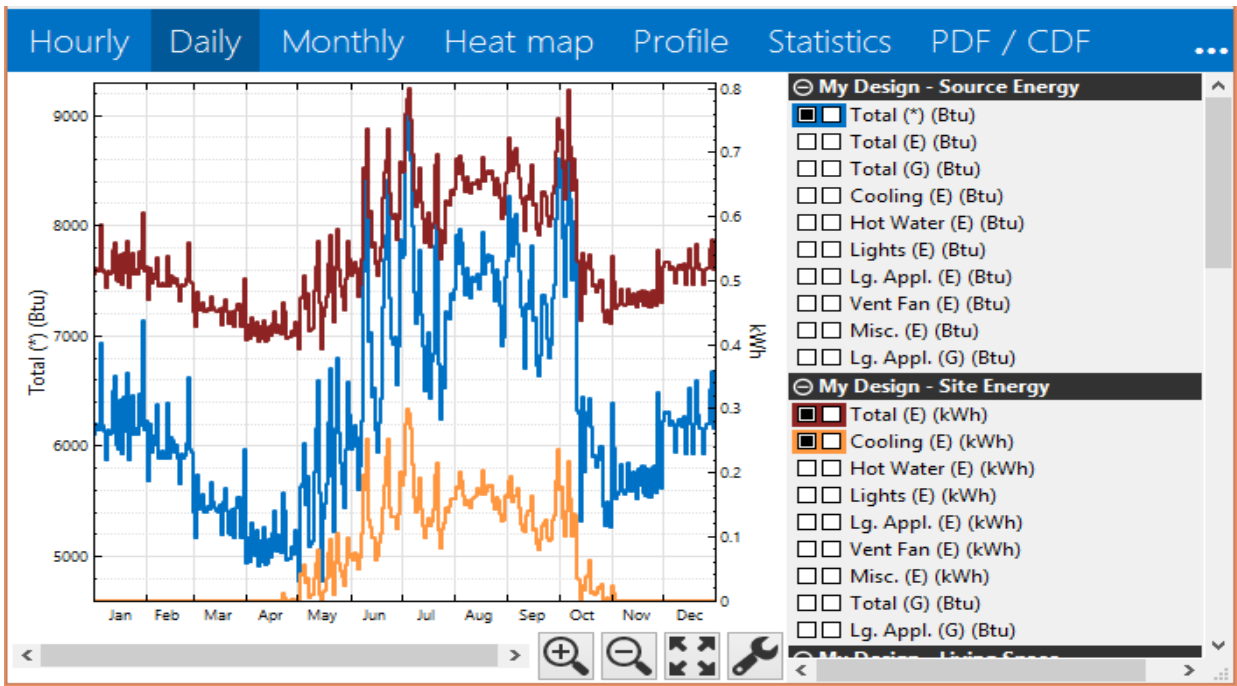

Fig. 2.13. Output in D-View

Monthly Output in D-View

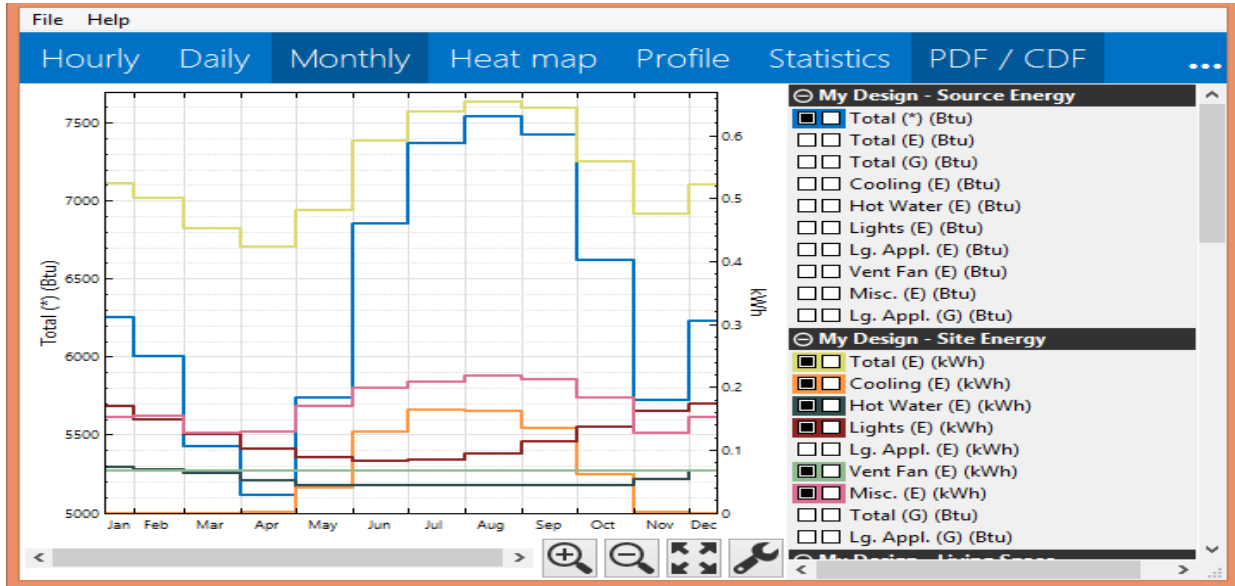

Fig. 2.14. Monthly Output in D-view

Yearly Profile:

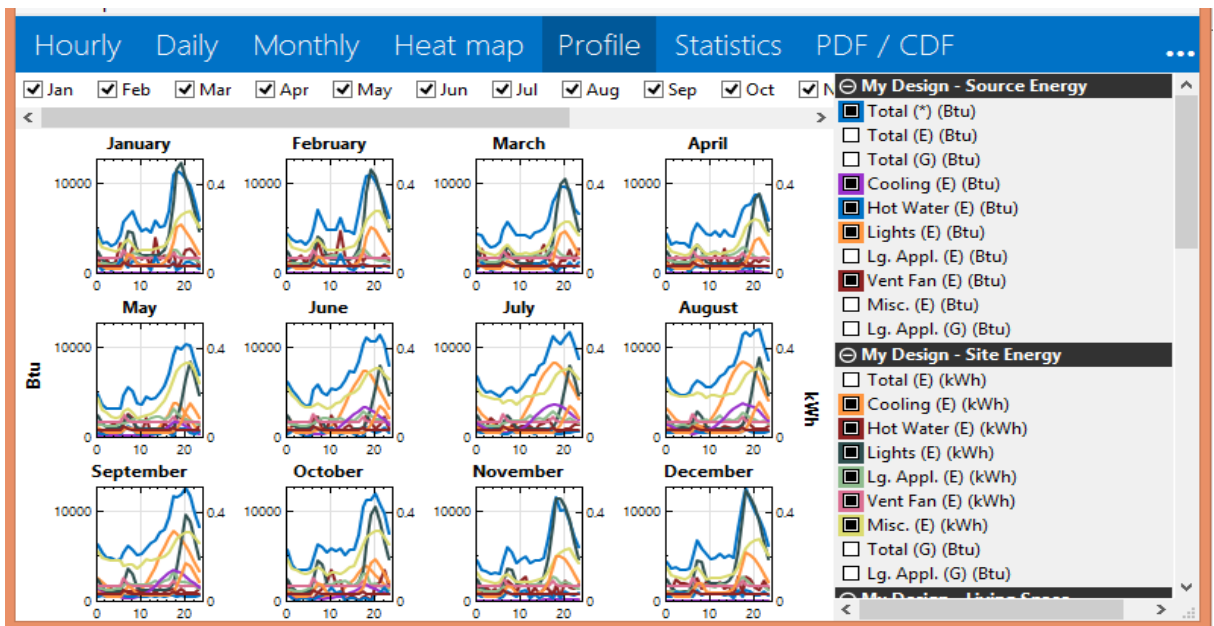

Fig. 2.15. Profile Output in D-View

This figure above shows the yearly consumption in kWh of site energy for each device and the biggest amount of energy consumption comes from cooling energy demand. In contrast, good materials and proper insulation for the roof, walls and other techniques will lead to a reduction of energy consumption in the house.

2.11 House Design Using Energy 3D Software

2.11.1 Energy 3D software definition

Energy 3D is a computer-assisted engineering tool for designing, analysing, and constructing green buildings that utilize renewable energy systems. This software also lets the users design a real looking building and then evaluate its energy performance for any given day and location. Energy 3D can swiftly generate time graphs (resembling data loggers). At the end of the design, 3D software allows users to print and cut out the pieces, and use them to compile a physical scale model. Energy 3D has been developed mainly to provide a simulated engineering design environment that supports science and engineering education. Moreover, its simulation results are quite accurate, and it may also be used as an entry level building simulation tool by energy professionals [32].

In the third case, this software is also used to generate the load and to calculate the energy consumption annually. The designing exposes that there are two main doors, one on the front side and the other on the north face. There is also a small door is on the back side of the house, and there are seven windows. The total area of the dwelling is 1962 ft² (183, 3 m²). The height of the house is 9 ft. (3m). In addition, Figure 2.14 below shows the structural design.

Design and Drawing of the House



Fig. 2.16. Shows the House Designed

On the right screen, there are some categories in which to put the parameters of the house, such as location and latitude. In this design, Egypt was selected because in the screen options there is not any information about Libya and it is located at the same latitude as Egypt. The conditions of the temperatures indoor and outdoor and the dimensions of the house are not given as well. The orientation of the house is east. The reason for this orientation is to protect the house from the rain that usually falls from the west side of the house in winter and also to protect it from the hot wind that always comes from that side, which is why there are only two small windows and proper insulation for that wall.

Output Mode Design

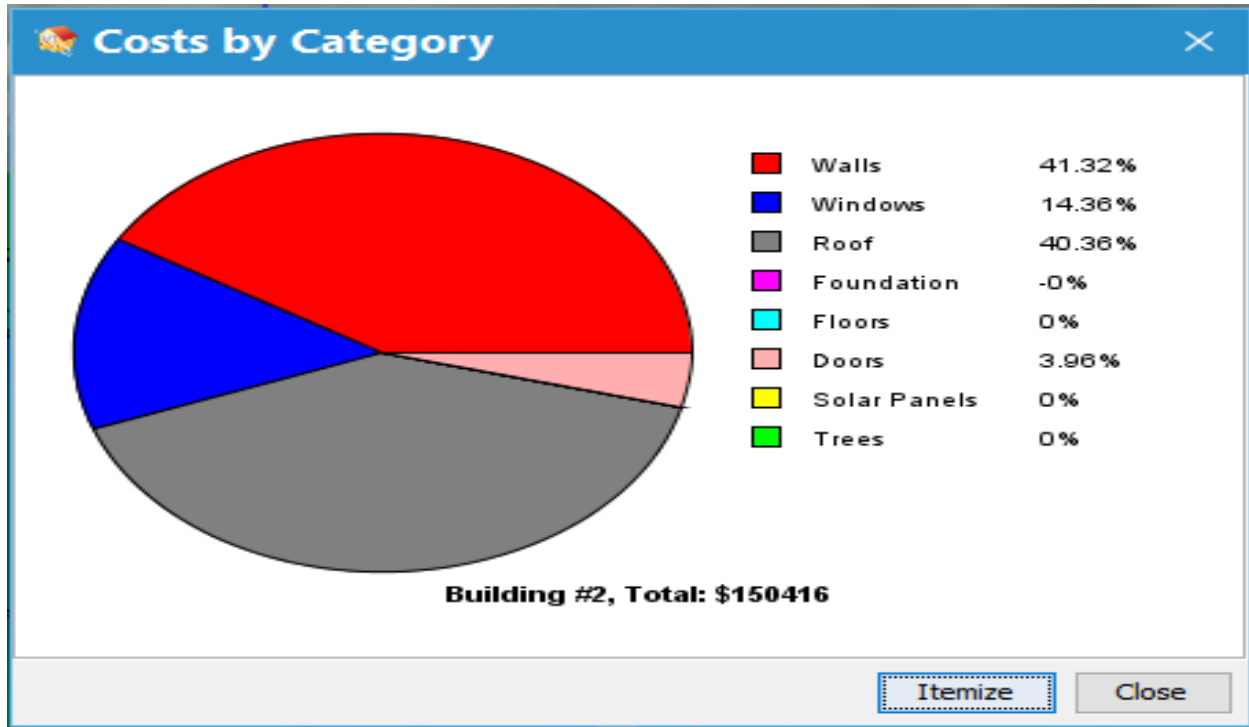

Fig. 2.17. Shows the House Design Costs

Figure 2.15 explains the costs by each unit of designing the house. For example, the biggest cost comes from the walls and the lowest cost is the doors, as shown in the figure. The walls represent the most ratio of the cost 40%. The second highest cost is the roof because the materials roof. Also, the total cost of the building is \$150416.

Output Mode Design

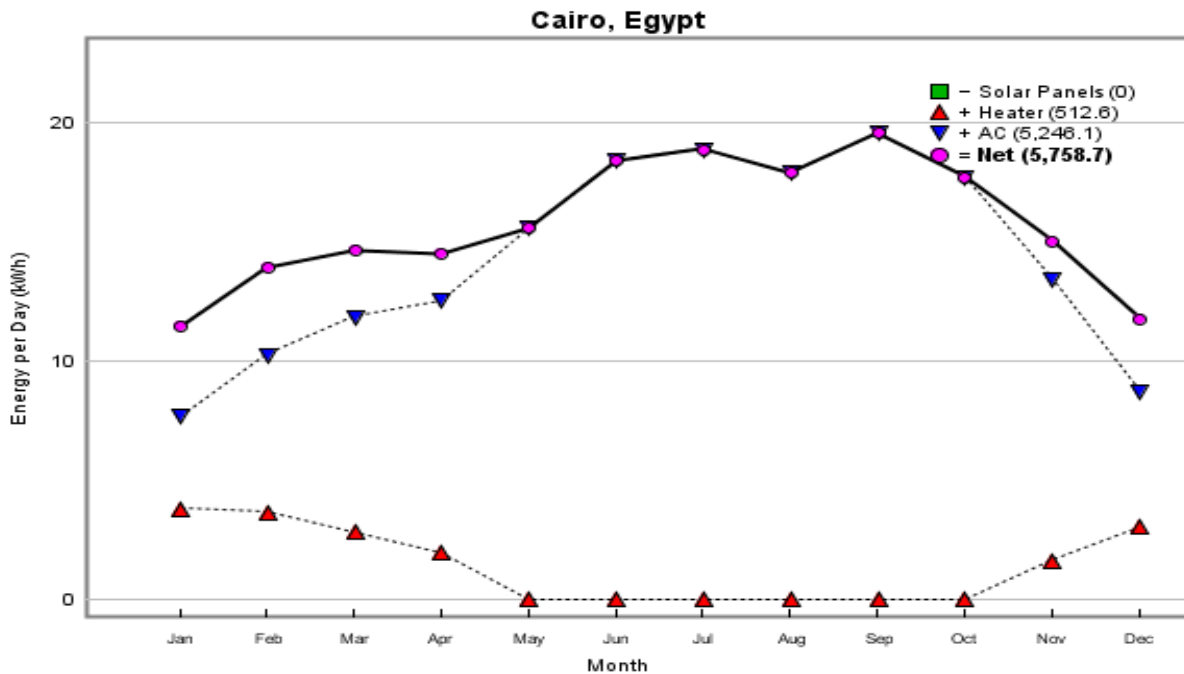

Fig. 2.18. Shows the Annual Energy Consumption of the House

This figure above shows the result of annual energy per day consumption in the house by two categories; the first one is the heater, which consumes around 1.175kWh/day. The energy consumption begins to increase starting from October to March and goes slightly down to zero kWh before the end of April due to heater load. In contrast, the AC load starts to consume the electricity in some early days of April and will increase from May to October and then also will go down gradually to be completely off through the next months. The most energy consumption in the house comes from the air conditioning loads. The net of annual energy as shown in this figure is 5758kWh/year. Using important and good materials such as insulation leads to less energy consumption in the house and some sustainable devices of renewable sources can be installed and utilized in order to provide electricity to the building and to minimize the energy consumption, CO₂ emissions and save as much money as possible.

Table 2.1 shows the Design House Using Different Software and Energy Consumption including Consumption with Connecting to the Grid

Type of Software/House Design	Annual Energy Consumption- Unit-Kwh/yr.	Unit-MMBtu/yr.	Notes
Conventional House – BEopt software	3526	1.2031e+7	First Design
Conventional House	7845	2.6768e+7	Connected to the Grid
Passive house (Sash)-BEopt software	4722	1.6112e+7	Second Design
Conventional House- Energy 3D software	5758	1.9647e+7	Third design

In the optimization mode, mainly energy and cost are optimized. Multiple options can be chosen from each category. BEopt considers each option and runs the simulation for every selected option. Several outputs are shown thus from which the most cost efficient and energy efficient result can be obtained.

The table 2.1 above shows the three types of simulation results. It can be seen that house design using modern tools by simulation that could to minimize the energy consumption in the house. The first design was applied as conventional house with its parameters. Nevertheless, the energy consumption was reduced from 7845 kWh/year to 3540 kWh/year. The second design was applied as passive house with changing some parameters such as the insulation for the roof and walls, this case also reduced the energy consumption from 7845 kWh/year to 4540 kWh/year and saved money as shown in the figure 2.9 and 2.12. The third design was done using energy 3D software to calculate the energy consumption with consideration of the insulation for the walls, roof and windows. The result was presented in the table 2.1. It is a 5758 kWh/year while the house was consumed 7845 kWh/year. Beside these new technologies and its utilized on such these projects, it can be led and contributed for creating clean environment. As well as it could to mitigate energy consumption in the dwellings by ratio 26.6 % and reduce the CO₂ emissions as well. Moreover, saving the money. With this a small amount of consumption, it has been designed a hybrid power off-grid system using Homer software to produce electricity through the renewable energy resources such as wind and sun energy with battery storage system. Why not? The sustainable resources are available with the developed technology as well. On the next chapter, there is a design of a hybrid energy system to produce electricity power to meet the requirements of the house load using a Homer software. In addition, renewable energy sources and its devices will be used and utilized.

Chapter 3

Sizing of a Hybrid Power System

In this chapter the main objective is to design a hybrid energy system that can provide enough electric power to meet the house load. As mentioned in Chapter 1 the house consumes 7845 kWh/year. BEopt software was used to simulate the house and add new parameters such as insulation for the walls and the roof. Using this method energy consumption could be minimized from 7845 kWh/year to 3540 kWh/year. Other objectives are the utilization of renewable resources that are inexhaustible such as by using solar panels and harnessing wind energy. With this small load, the sizing of a hybrid power system is necessary to meet the required load for that house. This plan and the notion of utilizing renewables are intended to keep the environment free of CO₂ emissions. This chapter also suggests that the house can be off-grid with such a hybrid renewable power system because it has the ability to provide the electric power for that house.

3.1 Introduction

In recent centuries, people all over the world have become more and more dependent on energy to meet their daily needs. Also, off the grid hybrid power systems have been utilized to supply electric power to rural areas, commercial buildings, government buildings and houses in all aspects, improving reliability, sustainability and environmental protection, especially for communities far away from the electric grid. This energy still relies on conventional sources such as coal, natural gas, diesel generators, crude oil, etc. (33). These sources, however, are being depleted rapidly, and this huge usage is going to threaten future

energy demand. Furthermore, these conventional resources such as fuels increase the emissions of greenhouse gases, exacerbating environmental issues and problems. Some of the radical solutions that consider the development and use of sustainable renewable energy resources may display the most efficient and active solutions. The hybrid power system combines renewable energy sources that provide a source of electricity that can be fed directly into buildings and can be stored in batteries for use when there is no generation power that comes from wind or sun energy under any conditions [34]. It has been established that renewable energy currently contributes only 11% of our primary energy; therefore, many countries have not yet utilized these natural resources such as Libya and other countries and still rely on conventional resources such as gas generation stations, oil power plants and steam power stations, resources that have significant impacts on the environment. A hybrid renewable set-up utilizes different combinations based on types of renewable resources that could be applied altogether to provide energy in the form used in off-grid and is supported by battery storage and/or other devices as backup systems, such as generators, etc.

3.2 City of Tripoli-Libya

Libya is located on the northern part of Africa and covers 1,759,540 square kilometers of land. The capital city of Libya is Tripoli, which has a population of 1,150,989, and is located at latitude of 32.88 and longitude of 13.19. Tripoli is also located on the Mediterranean Sea (35).



Fig. 3.1. The Location of Libya and the City of Tripoli

In Libya, the climate has several types of natural resources that can be utilized to generate power, particularly sun energy and/or wind energy. These resources are especially abundant near the coast. According to few papers written on the subject, Libya has great potential for generating electrical power from natural sources to feed houses loads; for example, government buildings and streets lights and/or other things that use electricity [36].

To attempt to avoid the negative environmental impacts of fossil fuel usage, it is important to find ways to economically utilize non-polluting sources of energy such as wind, solar energy, etc. Moreover, these two resources are sustainable systems and are considered as some of the cleanest sources of energy available today [36]. Countries have to take into account the drawbacks and advantages of using free resources in our daily lives in order to protect our future and also to create a cleaner environment for the next generations. Libya has the potential to become a renewable energy giant in response to climate change [37], as it has

a very high daily solar radiance rate due to its flat coast, with about $7.1\text{kWh/m}^2/\text{d}$ and in the south region, which has around $8.1\text{kWh/m}^2/\text{d}$. Also, if we compare the UK to Libya, Great Britain has less than half that amount at about $2.95\text{kWh/m}^2/\text{d}$. In addition, Libya's solar potential is 5X larger than its oil reserves. On the other hand, Libya can cover a significant portion of its electricity demand, especially for communities that are far from the city centers and require street lighting and energy for government buildings [38].

3.3 Renewable Energy Potential in Libya

This chapter aims to highlight the renewable resources potential of Libya using figures and results. The main objectives in this chapter are to describe the design of a hybrid energy system that can be used to generate enough electrical power to cover the house load and analyze its cost effectiveness. The specifics of solar and wind energy will be presented in this chapter. This type of energy relies on renewable resources and is unending over time. Regardless of the amount of energy available per unit time is called renewable energy [39]. There are many natural sources that can be used such as hydro power, solar, wind, biomass, geothermal, tidal and ocean energy. All these types of renewable energy come from the sun except tidal and geothermal energy. Therefore, this country has been chosen for this research, because it has massive sources of renewable energy with different potential such as wind, solar, hydro, and others resources that are still unknown. In this study, a hybrid power system can be applied to generate the electric power to meet the demand load of the house using wind energy, solar energy and battery storage as a backup system. All existing power generation systems in Libya are extremely reliant on hydropower and gas power [40]. Although Libya has great potential for these kinds of renewable sources that can be utilized for providing the electricity power they are still unused.

In this research, we have also designed a hybrid power system to produce electric power for the house based on its assumed load using Homer software. All graphs, figures and results will be presented in the next pages and explained carefully.

3.4 Assumptions and model inputs

3.4.1 Load

The load profile was used for this study based on the actual bills of the house that are reported by the general electric company in that region. Figure 1 illustrates this profile, a base load of 1kWh/d throughout the day and night. A small peak occurs in the morning, and a few hours before noon it reaches 0.8kW and slightly increases again while most of the load occurs in the evening with a peak load of 0.95kW scaled, including compact bulbs and some DC voltage devices such as TVs, etc. The total daily load average is 7.9 kWh per day.

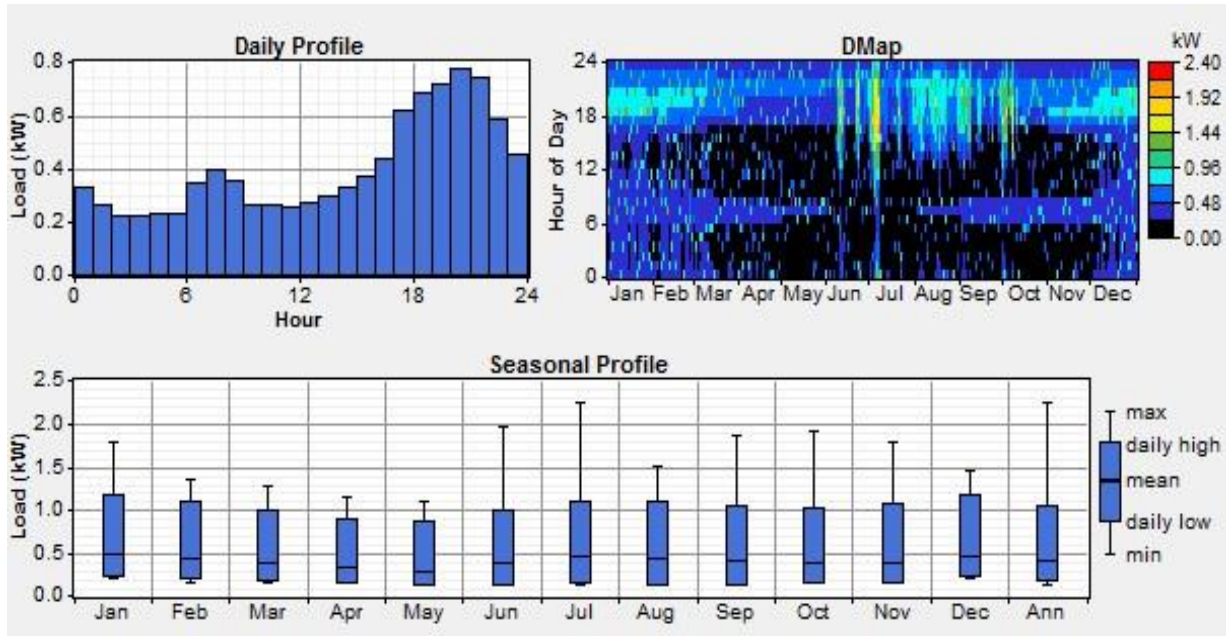

Fig. 3.2. Hourly Load Profile for the House

3.4.2 Hybrid Power System for a House in Libya

The figure below indicates that the applicable renewable sources in that region are wind, and solar panels. Subsequently, a hybrid power system consists of a primary load of 9.7kWh/d, 2.3kW peaks that are connected to the AC bus while the PV models, 6FM200D battery, and SW Air-X 400W wind turbine type are connected to the DC bus. A converter device is connected between the AC buses to the DC bus. Every design is different which means that each should be designed for the particular site depending on the available sources and the load. The proposed hybrid energy system will produce electric power to meet the estimated load of the house at minimum cost using Homer software. The figures below will show the results that are related to the aim of this study. There are several factories that manufacture these devices with different types which can easily be bought and installed, especially for buildings such as houses or offices and small communities. The sizing of a hybrid system can be done using Homer. Figure 3 below shows the components of the system.

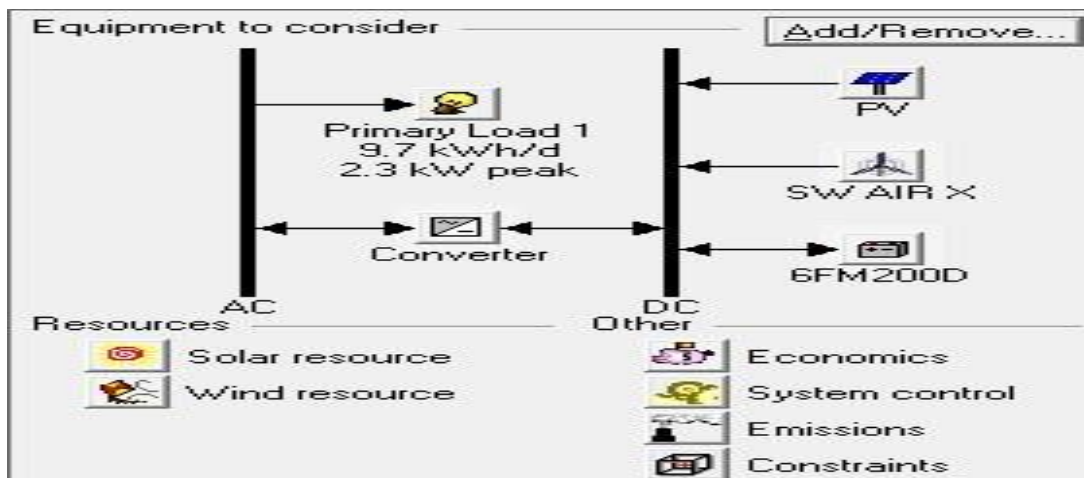

Fig. 3.3 Hybrid Power Systems from Homer Simulation

3.5 Standard for design

Design parameters for achieving the purpose of a sizing hybrid system should follow any standards those are typically applied in the country or region where the solar insolation will occur. Some countries have taken these standards into account such as Australia, New Zealand and the US. In other words, these standards are often updated and amended so the latest version should always be applied [41].

3.6 Homer software definition

This software was developed by the National Renewable Energy Laboratory for supporting the U.S. Department of Energy's Building America program. It is also used in this analysis, which facilitates the function of the estimating design of both off-grid and grid-connected power systems for diverse applications. In sizing a hybrid power system, numerous resolutions about the arrangement of the system are to be made: the components which will be used in the system design, the sizing of each component to use, etc. However, there are a number of technological options and the divergence in technology costs and available resources make these decisions difficult. That said, Homer's optimization and sensitivity analysis algorithms make it easier to evaluate the many possible system configurations [42]. This software also simulates the operation of a system through making energy balance calculations and the analysis of a list of configurations, arranged by net present cost that can be used to compare system sizing.

3.7 Wind energy and solar resources

3.7.1 Solar Radiation

As mentioned in the introduction, Tripoli-Libya is rich in wind energy and sun energy; however, they are yet unused because of a lack of local experts and the skills needed to harness them. Solar resources are imported directly by Homer from NASA's surface meteorology and their database by entering the GPS coordinates. The annual solar radiation of this area is 5.044 kWh/m^2 , and its potential is quite excellent, especially from March to September. Figure 4 on the next page demonstrates this. Thus, the geographic location of the site is $32^{\circ}.88$ Latitude (N°) and $13^{\circ}.19$ Longitude (E°). It would be better if the average irradiation was constant and the annual irradiation is above 4kWh/m^2 in order to have a dependable source of power from the photovoltaic panels. Figure 4 below indicates daily radiation and the clearness index [43].

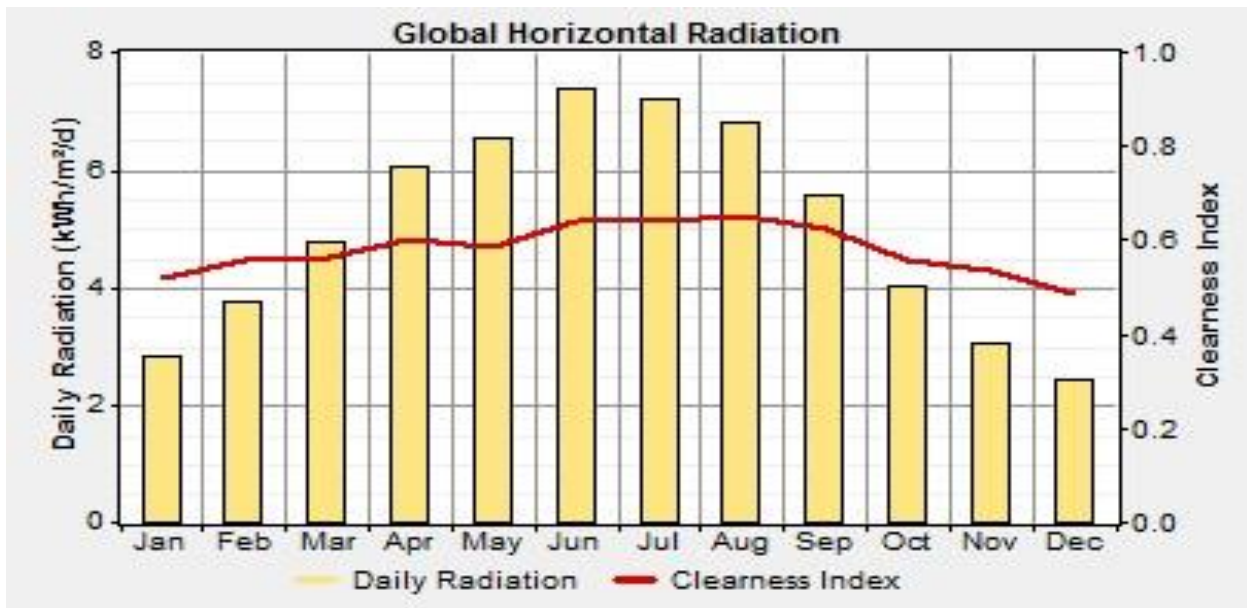

Fig. 3.4. Solar Radiation Profile for Tripoli-Libya Plotted in HOMER

The solar resource was used for a site in the city of Tripoli-Libya at the location of 32°:88⁰ N⁰ latitude and 13°:19⁰ E⁰ longitude. The solar data for this region was obtained from a solar energy website and NASA's surface meteorology. As indicated in Figure 4, the annual average solar radiation for that area is 5.044kWh/m²/d and the solar resource profile over a one year period is shown. Thus, it is clear that, the daily radiation starts increasing from March to August and then decreases gradually, as is shown in the figure.

3.7.2 Wind resource

The energy made available by the wind relies on the wind intensity and air velocity. This is affected by changes in the pressure and temperature, which vary with the high level of the sea. The equation below can be used to determine the energy of a mass of air by the Kinetic Energy (K.E) flux (44).

$$P_w = \frac{1}{2} C_p * \rho * A * V^3 \quad (3.1)$$

Where P is wind power and C_p is the turbine power coefficient. ρ= an air density (kg/m³), and V is the wind speed. A is the rotor swept area = $\frac{\pi D^2}{4}$ (m²) [44].

Wind resources are determined using NASA's surface meteorology as an accurate reference (<http://eosweb.larc.nasa.gov/>) considering the wind direction at 50 meters above the surface of the earth. The database provides the monthly wind speed average for that month over a 7-year period (January 2009- February 2015) [45]. Also, both Figure 8 and Table 1 show that the peak wind speed occurs in January. February and March have less than 5m/s, and then it is variable from April to September with a rating between 3.5 m/s to 4.2m/s. For the rest of the months, the wind speed is usually 5m/s or less.

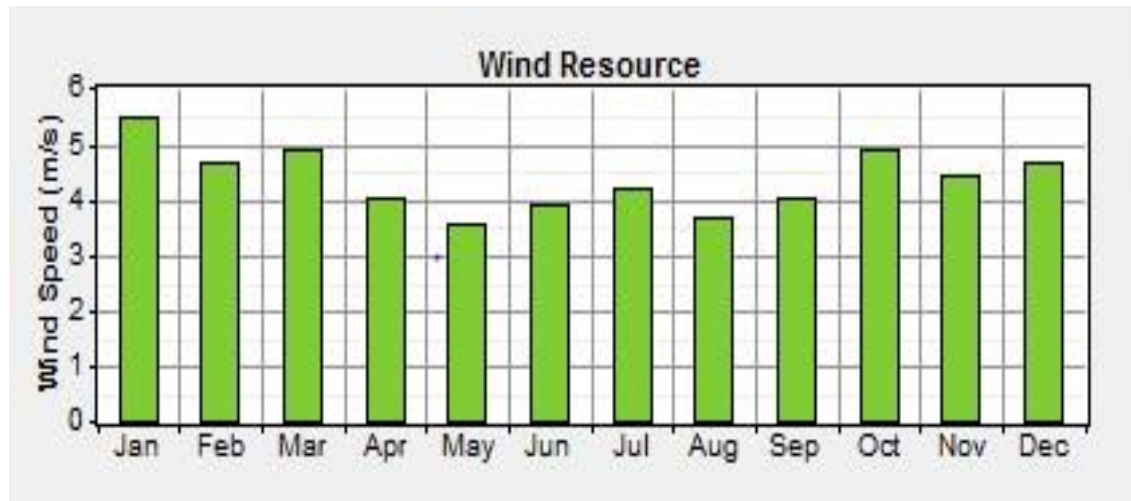

Fig. 3.5. Wind Speed Profile for Tripoli-Libya Plotted in HOMER

We can safely say that the wind provides a plentiful, free, clean, sustainable and environmentally-friendly renewable energy system. For many centuries, people have used the wind for simple things in their lives such as driving windmills to grind grain and pump water, and nowadays also for electrical power production (Johnson, 2006) [45]. Many places in the world have the potential for producing considerable wind energy, and it should be considered and to be utilized for the next generation. For the time being, people are looking for new resources and modern energy technologies that are cheaper than conventional resources that generate CO₂ emissions and will be depleted. For this purpose, there are a great number of scientific studies examining battery power as unfailing sources of energy such as renewables, solar and wind.

Table 3.1 Monthly Averages Wind Speed of Tripoli from HOMER Simulation

Month	Wind Speed (m/s)
January	5.495
February	4.679
March	4.881
April	4.006
May	3.574
June	3.892
July	4.214
August	3.668
September	4.004
October	4.864
November	4.452
December	4.657
Annual average:	4.366



400W Air X Residential Wind Turbine,
Off Grid

Table 3.1 shows the monthly average wind speed for that region using Homer software simulation. It is clear that the lowest wind speed occurs between May and June. However, the wind speed in the rest of the months is above 4.006 m/s and reaches 5.5 m/s. This potential is more than enough to keep the generator working.

3.7.3 Wind Power Working

Wind turbines use blades that have a shape like aircraft wings. These blades are mounted on the central shaft. The force of the wind turns the blades, converting the energy of the wind into mechanical energy through the rotating shaft. In this way, the shaft is used to turn a generator to produce electricity. However, most modern wind turbines are used for

electricity generation. Figure 3.6 below illustrates how the wind turbine works and each part [46].

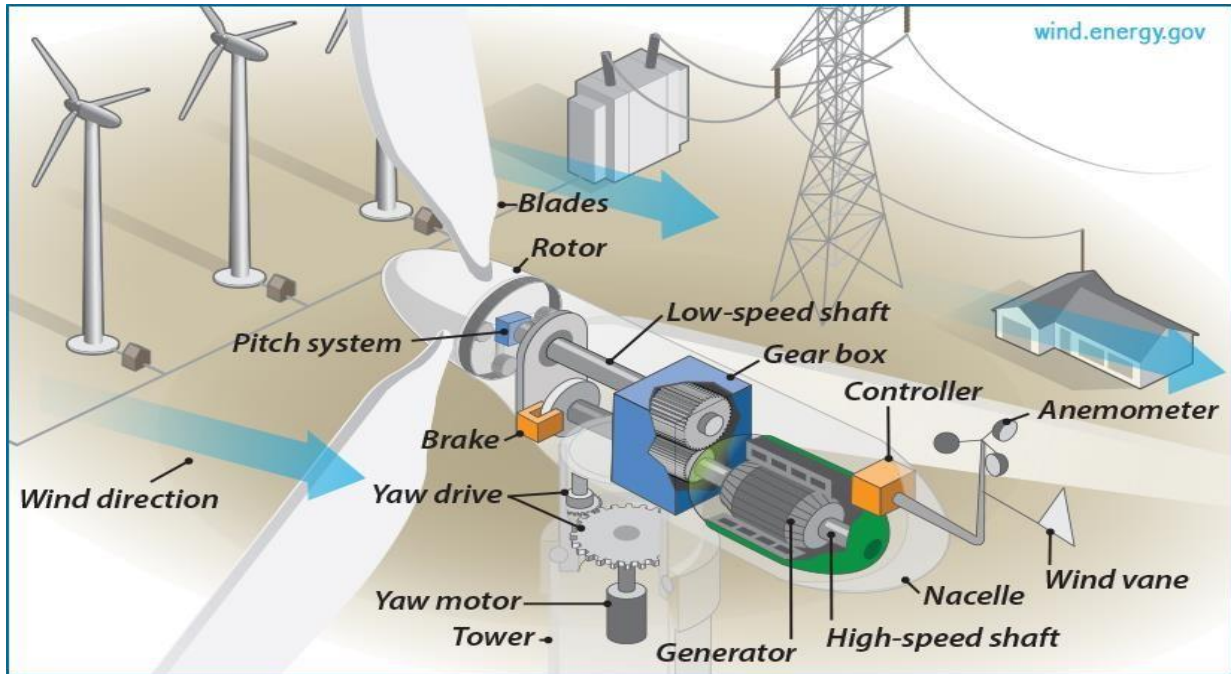

Fig. 3.6. Wind Turbine Installation and its Parts

3.7.4 Wind Turbine Specifications

400W AIR X was chosen for this research; it has been designed carefully and developed. This wind turbine is equipped with sophisticated electronics designed to provide protection from overcurrent electrical dangers. Also, these electronics have good features and duties such as preventing open circuit voltages from rising above 50 volt for 48 volt systems or above 24 volt for 24 volt systems. Table 3.2 below shows the details related to the wind turbine [47].

Table 3.2 Shows the Characteristics of the 400 W Airs X Wind Turbine

Type and Name	kWh	Volts & W	Values	Speed
Rotor Diameter			46 inches (1.15)	
Weight			13 lbs.	
Start-up Wind Speed				7 mph (3.13)
Voltage		48VDC		
Rated Power	0.4 kW			28 mph (12.5)
Turbine Controller	Microprocessor-based smart internal regulator with peak power tracking			
Blade	Three – Carbon Fiber Composite			
Body	Cast aluminum (Air-X Marine is powder-coated for corrosion protection)			
Kilowatt Hours/m	38			12mph (5.4 m/s)
Warranty	3-year Limited Warranty			
Survival Wind Speed	110 mph (49.2 m/s)			
Over-Speed Protection	Electronic Torque Control			

3.7.5 Wind Turbine Curve

This graph below shows the relationship between the power and wind speed.

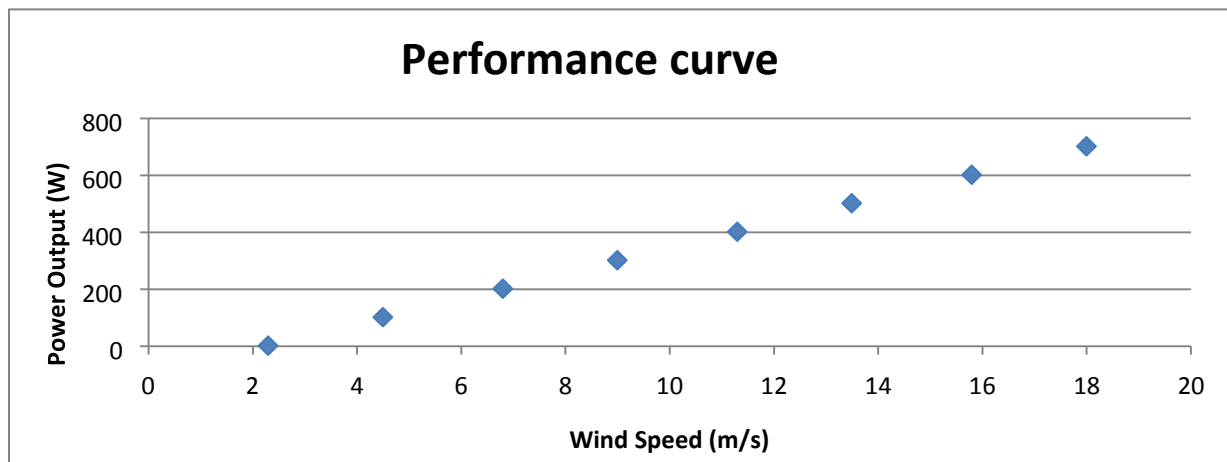

Fig. 3.7. Wind Power Output (W) and Wind Speed (m/s).

When the wind speed is more the 3 m/s, then power starts to be produced. As seen in the graph above this starts with almost 100 Watts and as long as the wind speed continues the power is produced until reaching the rated power with 400 Watts.

3.7.6 Wind Power Modeling

The diagram below shows the transformation process of wind energy to electrical energy as in Figure 3.8

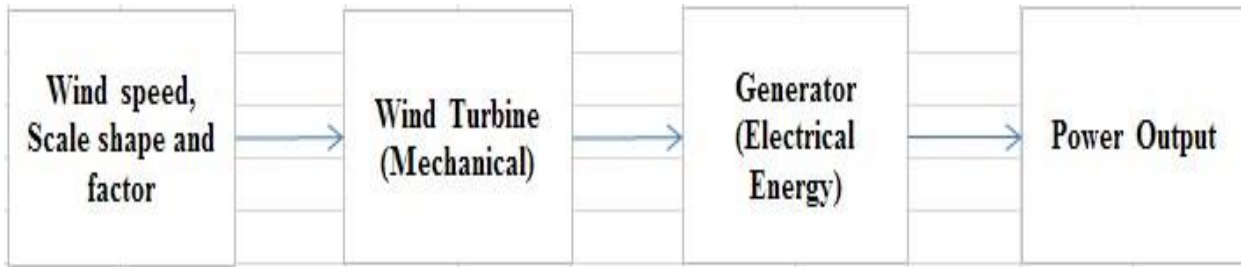

Fig. 3.8. Energy Conversion from Wind to Electricity

There are many different mathematical models that have been developed for assisting in explaining the expectations of the output power production of wind turbine generators (WTG). For example, the Weibull distribution function is commonly used to determine the wind distribution in the chosen site of the annual/monthly and mean wind speed of the site. Below is the Weibull distribution equation [47].

$$f(v) = \frac{k}{c} \left(\frac{v}{c}\right)^{k-1} \exp\left[-\left(\frac{v}{c}\right)^k\right] \quad (3.2)$$

Where v = Wind Speed, c = Scale Parameter, k = Shape Parameter. Both k and c can be expressed as function of average and standard deviation of wind speed.

The parameters K and C (m/s) are therefore used to characterize the Weibull distribution. To determine K and C , the approximations vastly accepted are given in equations 2 and 3, respectively.

$$K = \left(\frac{a}{V} \right) - 1.09 \quad (3.3)$$

$$C = \frac{V * k * 2.6674}{(0.184 + 0.816 * K * 2.73859)} \quad (3.4)$$

Where σ = standard deviation of the wind speed for the site (m/s) and V = mean speed (m/s).

3.8 Solar Energy

The sun is the earth's greatest energy source, and is the ultimate source of all energy. Solar energy is released to the cosmos by electromagnetic radiation and approximately one-third of energy radiated from the sun is reflected. Then, the rest is absorbed and retransmitted to space, while the earth reradiates only as much energy as it received and then creates a stable energy balance at a temperature suitable for life. In addition, solar irradiation provides the earth with a large amount of energy [47]. This amount of energy that comes from the sun to the earth's surface equals 10,000 times the annual global energy consumption. There are generally two ways to generate electricity from sunlight. The first is Photovoltaic (PV) and the second is a solar thermal system. In this thesis, a photovoltaic power system is used because a significant feature of PV is that it can produce electricity when the sky is overcast. To determine the PV electricity generation potential for a specific site, we should assess the average total solar radiation received over the year.

3.8.1 PV Module and Battery Specifications

Photovoltaic systems are manufactured from semiconductor material, such as silicon, which is presently the most commonly used element in the semiconductor industry. The notion of how it works is that when the light strikes the cell a certain portion of it is absorbed within the semiconductor material [48]. PV cells have one or more electric fields that force electrons that are freed by light absorption to flow in a certain direction. The PV was selected; it is 200W mono-crystalline, and its efficiency is 18.70 %. The nominal voltage is 12 volts; it is of a high quality. Each cell produces 200W. The calculation of the array size of the panels will be presented in the next pages. The Mono-crystalline 200W PV module, as shown in the Figure 3.8 was used in the simulation. The value from the modules Homer needed for the simulations were: Temperature Coefficient of power $-0.40^0\%$ C and normal operating cell to 85^0 C. Other input parameters for PV were left at their default values. Thus, the ground reflectance was set at 20% and it would be a typical value for the green area.

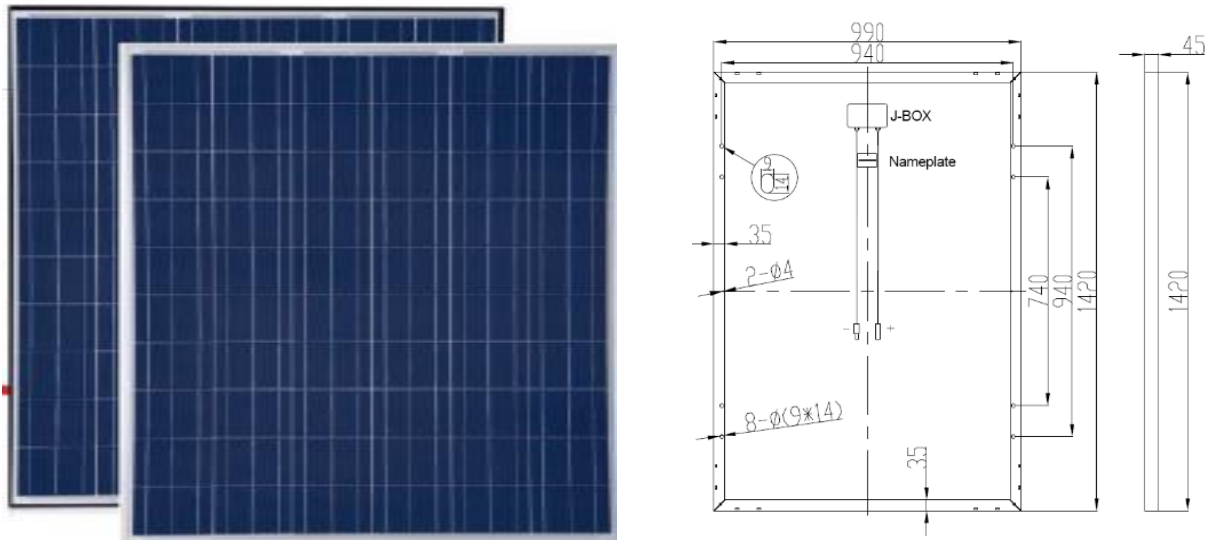

Fig. 3.9. Solar Panel 200 Watt Mono-Crystalline and its Dimensions

The typical mono-crystalline solar cell is a dark black color, and the corners of the cells are usually missing as a result of the production process and also the physical nature of mono-crystalline silicon. This is foremost because it is the second most plentiful element in the earth's crust. In the long run, it should be clear to many industry experts that silicon-based solar energy panels should be the most affordable method of generating renewable electricity from the sun. This type of silicon goes through several cycles of slow and energy intensive filtration and separation processes and thus is the most expensive type of silicon. This type was used for this study and all its parameters were input into the Homer software as shown in Figure 3.10.

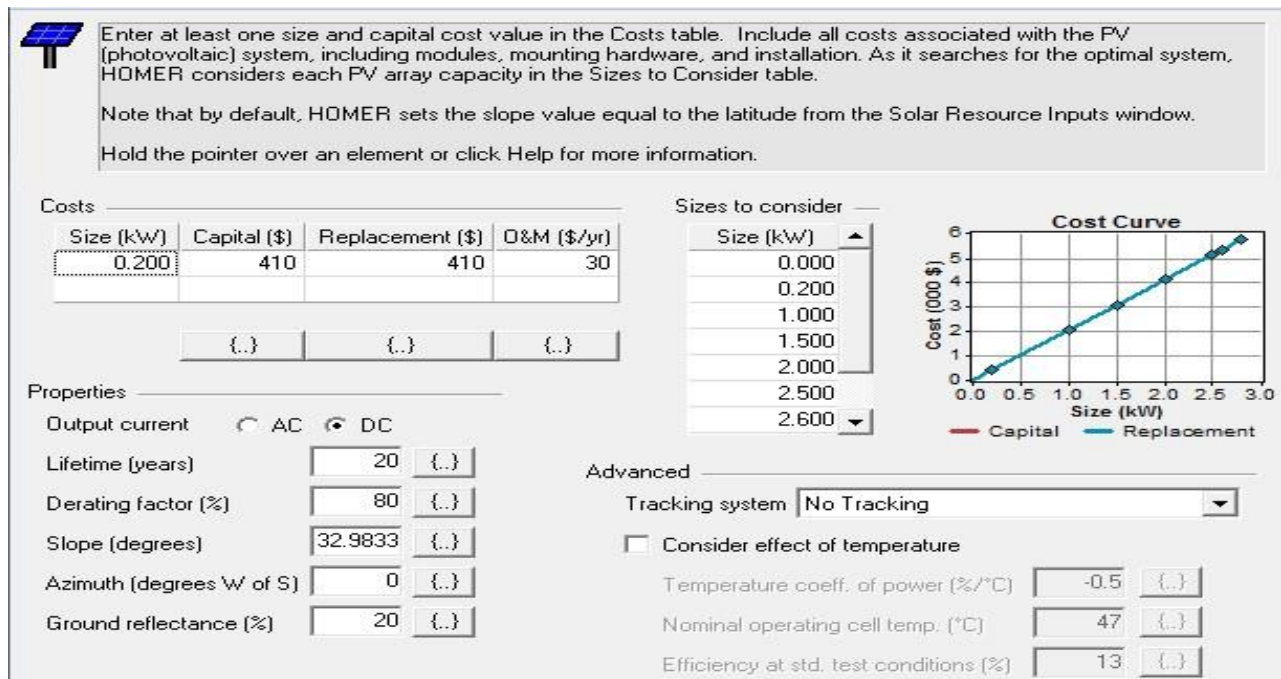

Fig. 3.10. PV System Input in Homer Software

3.8.2 PV Array and its Calculations

A PV array is simply a correlation between several photovoltaic modules in series and/or parallel. When individual modules are used, however, it may not be adequate to cover the requirement of the load. Usually, the modules are connected in a series type to obtain the required voltage, and then the strings obtained are connected in parallel in order to produce more current based on the requirement. As well the same connected at batteries. Figure 3.11 shows the connection of the solar modules array and the calculation will be presented on the next page.

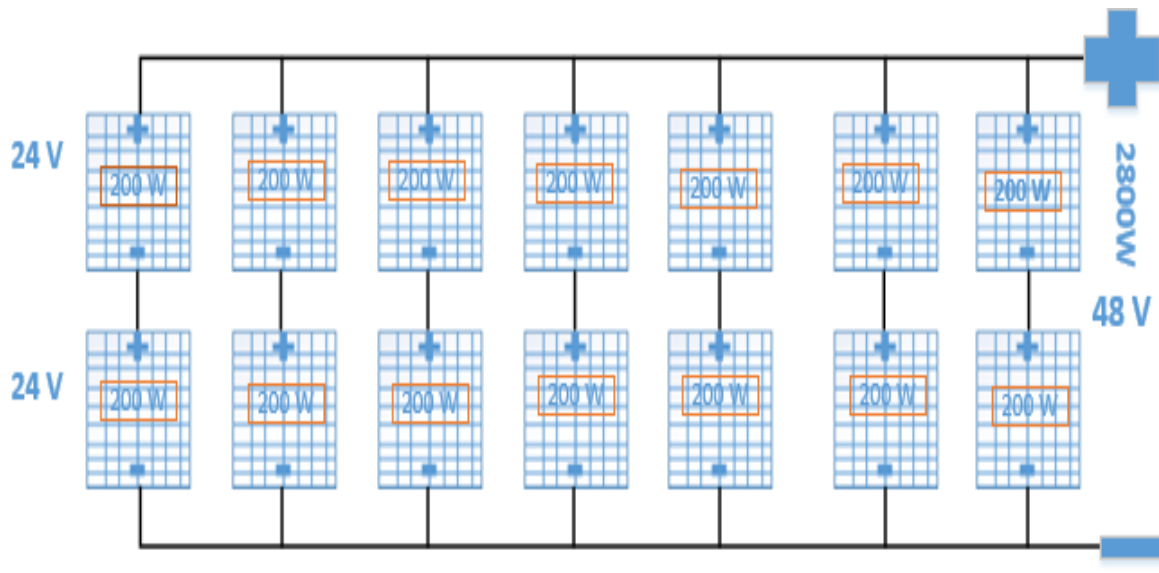

Fig. 3.11. Connections of Solar Modules in Series- Parallel

We can calculate the size of the PV array through the following equations as shown below.

The load = 9.7kWh/d. The peak load = 2.3Kw. The global solar = 5.03kWh/m²/d.

As mentioned on page fifteen (15) the size of the cell is as follows:

The length is 1580 mm, the width is 808 mm, and the thickness is 35 mm. The calculations are as follows. Area of PV

$$\text{Area of PV} = 1.58\text{m} * 0.808\text{m} = 1.27664\text{m}^2 \approx 1.28\text{m}^2 \quad (3.5)$$

$$\begin{aligned} \text{Array size} &= \frac{\text{load kWh/d}}{\text{Solar radiation kWh/m}^2/\text{d} * \text{PV efficiency \%} * \text{Fixed solar \%}} \\ &= \frac{9.7}{5.03 * 0.13 * 0.7} = 21.19 \text{ m}^2 \end{aligned} \quad (3.6)$$

$$\text{Number of Panels} = \frac{21.19}{1.28} = 16.55 \approx 16 \text{ Panels} \quad (3.7)$$

$$\text{Cost of Panels} = 16 * 410 = \$ 6560 \quad (3.8)$$

3.8.3 Factors that Impact the Operation of the Solar Module

There are basically four major factors that are impacting the operation of the solar performance modules as written below:

- **Material of Cell:** The materials type and manufacturing method used. There are several kinds of cells. For example, the efficiency of amorphous silicon is from 5% to 7% and polycrystalline silicon's efficiency does not exceed 12%, but mono-

crystalline has over 12% efficiency and was therefore selected for this research (Electronica, 2014) [49].

- The irradiance concentration on the module output: the current output is proportionate to the radiation intensity, which means if the light intensity increases then the current will increase too, but the voltage does not change frequently.
- Heat on the module output: an increase in the temperature of the module most likely will have an influence on the output voltage of the module. Therefore, the difference of temperatures through the operating solar module is expressed as the equation below:

$$T_c - T_a = (NO_{TC} - 20) * G / 800 \quad (3.9)$$

- Shading impact on module output: this situation usually happens when there are trees or any other building beside it, which means the modules, or part of it (cell) is shaded, and then it will produce partial electricity or may produce none. However, there is a way in which can be used and be mitigated by installing bypass diodes (Stapleton, et al., 2012) [50].

3.9 Storage Batteries System

There are several types of systems for storing energy. Storage technology is pivotal to assuring a continuous supply of power to the load [51]. In this research, 6FM200D batteries 16, 200Ah units were used. Their general features include Absorbent Glass Mat (AGM) technology for efficient gas recombination of up to 99% and freedom from electrolyte maintenance or water adding. They can be mounted in any orientation, and have a computer designed lead, and calcium tin alloy grid for high power density. Moreover, they have a long service life, float or cyclic applications, maintenance-free operation and low self-discharge. An off-grid hybrid energy system needs a bank of batteries to keep the system working and with a high efficiency. This is the type of battery that was selected as seen in the figure below.

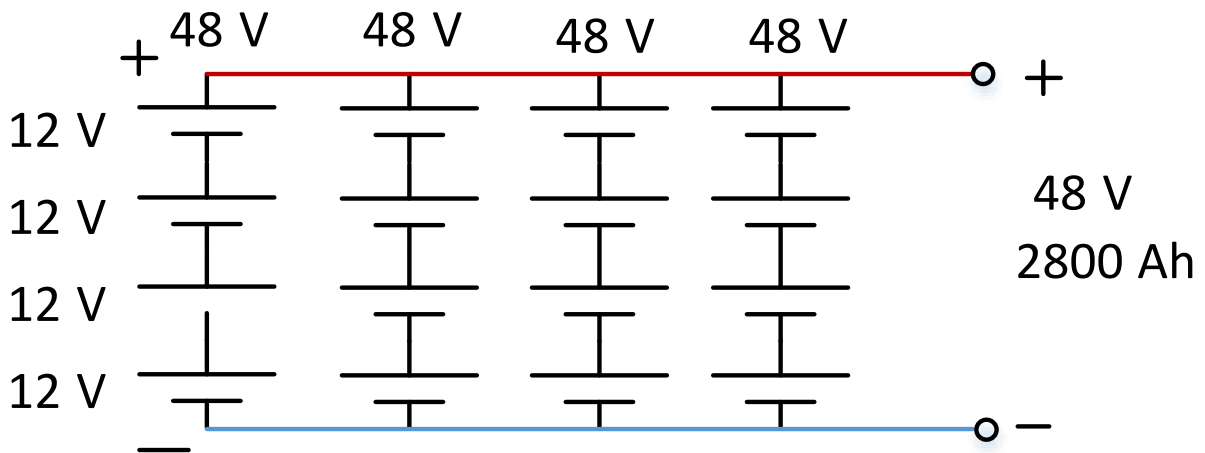

Fig. 3.12. Selected Battery Type for the Simulation in Homer



Fig.3.13 Version 6FM 200D Battery, www.vision-batt.com

The calculation of how many batteries per string will be presented on this page. Also, many inverters/charges are available for off-grid system work in these types of DC/AC voltages.

3.9.1 Battery Information

Battery is 48V Bus, 200Ah.

Primary load is 9.7kWh/d.

Backup is 3 days.

Battery efficiency is 80%.

$$\text{Number of strings} = \frac{9.7\text{kWh} / \text{d} * 3\text{days backup}}{48 * 0.8 * 200} = 3.79 \approx 4 \text{ strings} \quad (3.10)$$

$$\text{Number of batteries} = 4 * 14 = 56 \text{ Batteries} \quad (3.11)$$

$$\text{Cost of batteries} = 56 * \$560 = \$ 31,360 \text{ for 4 years} \quad (3.12)$$

3.10 Components and their tasks

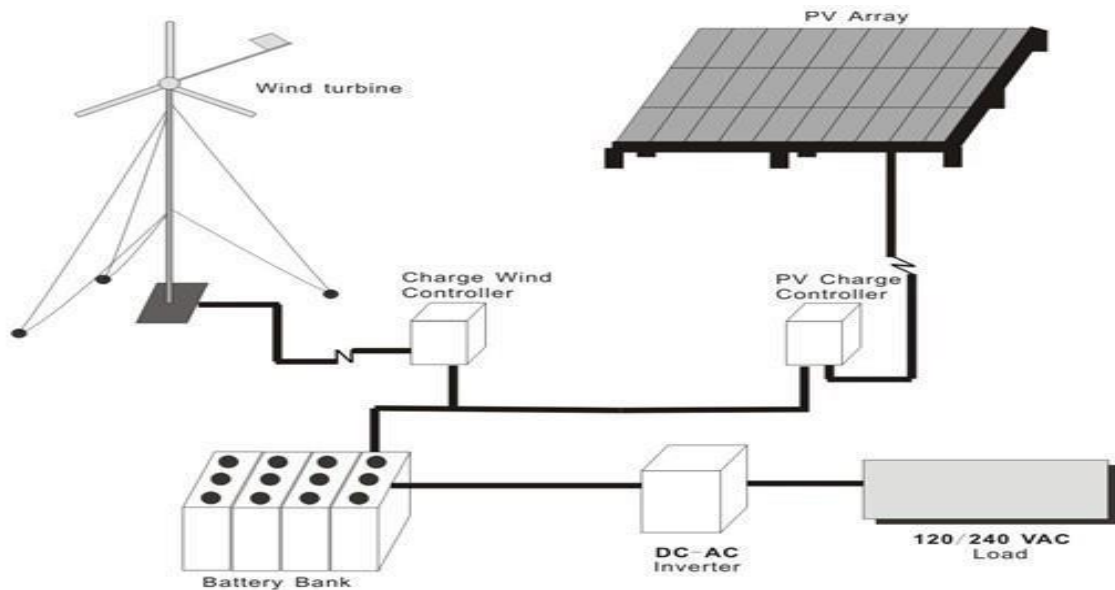

Fig. 3.14. Components of a Hybrid Power System [52]

The proposed hybrid power system consists of five or six parts and most of them have been presented previously. However, there are two important parts: the converter and the charge controller as shown in the figure above.

3.11 Converter Device

To design a hybrid energy system, a converter is needed. This device basically converts electricity from DC to AC in a process called inversion, and it also transforms from AC to DC in a process called rectification. In this proposed design scheme the converter contains both a rectifier and inverter. The PV panels, the wind generator, and the battery sub-system are connected with a DC bus. The inverter and the electric load are connected with an AC bus

[20]. The inverter and rectifier efficiencies were supposed to be 90% and 85% for this research [53]. The inverter capacity size was selected as 2.5kW at a cost of \$1,600 US and the inverter's lifetime is 15 years. Operating and maintenance costs are assumed to be 0.06% of the inverter cost. The inverter template for the photovoltaic generator and battery bank is given below:

$$E_{PVG} - IN^{(t)} = E_{PVG}^{(t)} * \mu INV \quad (3.13)$$

$$E_{BAT-INV^{(t)}} = \left[\frac{E_{BAT}^{(t-1)} load^{(t)}}{\mu DCHG} \right] \quad (3.14)$$

This 2.5kW inverter was used. It has some good features such as a true sine wave output TDH smaller than 3%, USB charge port, high frequency design, is adapted for capacity, and has an inductive load and Input polarity/UVP/OVP/OSP/OLP/OTP and LED display input, output level and failure status.



<https://www.alibaba.com>

3.12 Charge Controller

In this chapter, the proposed hybrid power system consists of renewable energy devices to provide power for the house (off-grid house). Some devices are mentioned in the previous pages. A charge controller is the major part of any wind or solar system which guarantees that the batteries are not over or under charged. In this chapter, the proposed hybrid power system consists of renewable energy devices that provide power for the house (off-grid house). Some devices are mentioned in previous pages. There are several types of charge controllers and their purpose is to monitor the battery voltage and switch off the charge when it is fully charged, as well as switch back on the charge when it reaches a pre-set level of discharge. This circuit below shows the schematic diagram of the charge controller for the PV, Wind Turbine and Battery devices [54].

http://www.thebackshed.com/forum/forum_posts.asp?TID=4732&PN=1

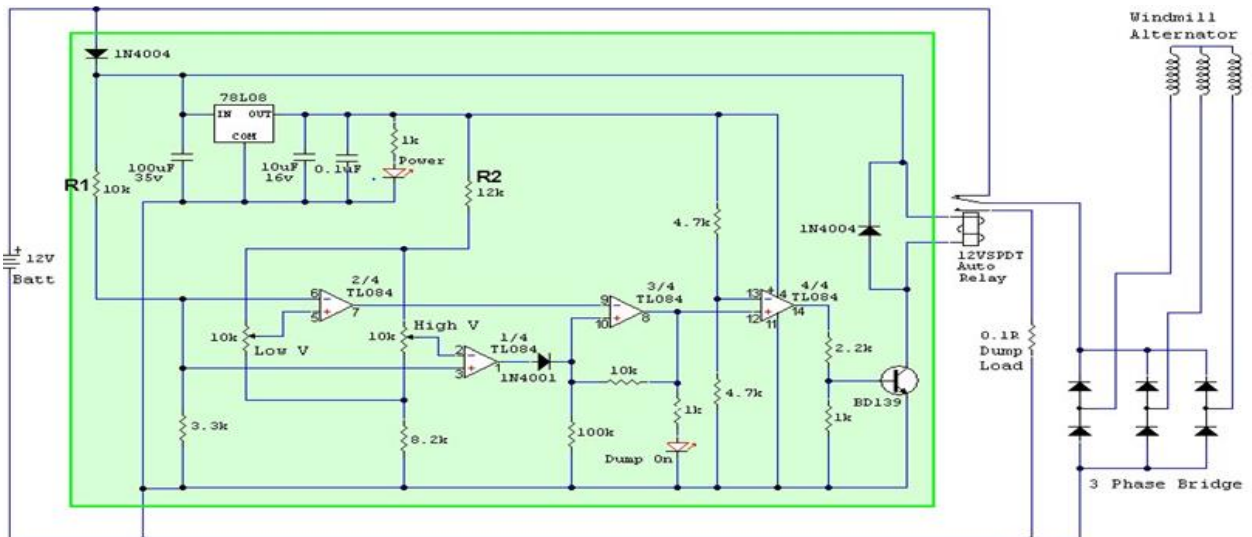

Fig.3.15. Circuit Diagram of the Charge Controller [55]

Table. 3.3 Components System Considered

Components	Size	Capital Cost (\$)	Replacement Cost (\$)	O&M Cost (\$)	Lifetime
PV Panel	200W	750	750	40	25 years
Three Wind Turbine & Tower	3x0.4kW	17,325	15,000	100	25 years
Battery	200Ah	500-650	650	40	5 years
Converter	2.5kW	400	260	80	15 years

The table above 3.3 shows the components’ prices, lifetime, capital cost and the operation- maintenance for each device and replacement cost as well.

3.13 Wind Turbine and PV Panel Electric Production

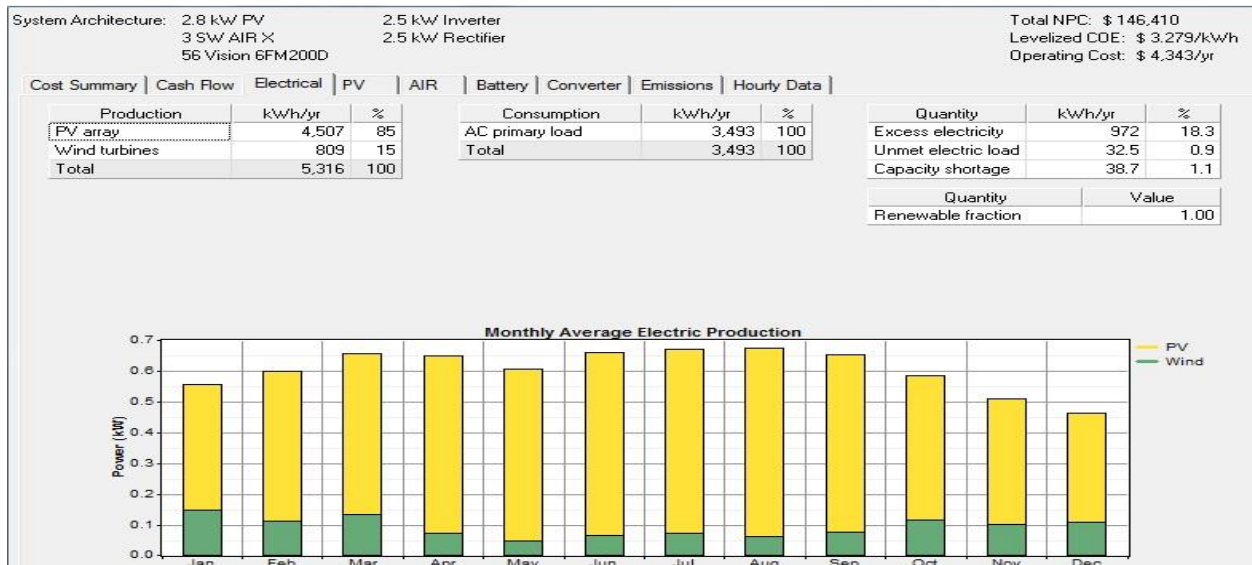

Fig. 3.16. Expected Electrical Performance Result

Figure 3.15 above displays the monthly average electric production that comes from the PV panel and wind turbine. The source of the wind speed in that region has the most potential in January, February and March and then it decreases slightly until October. Therefore, in this study PV panels are mostly relied on to produce the electric power needed to cover the energy consumption demands for that house.

3.14 Simulation Results from Homer Software

By clicking on each of the presented solutions, we can access a comprehensive series of data that provide a high level of detail on each system component. Further, simulations were run in the Homer software for diverse configuration system types of the power system in order to gain the most efficient system configuration that will give the lowest net present cost to determine the foundation of energy efficiency. Figure 3.16 illustrates all the possible configurations and results that can be obtained using the various power resources. The cost of units that is used through operating hours was specified. Some economic inputs allow entering of the interest rate, project lifetime, and other inputs which affected the system. System costs are indicated in Figure 3.17 below. The renewable fraction hybrid system is 100%. Such a system would be off-grid. Figure 3.17 indicates the optimization result as shown below.

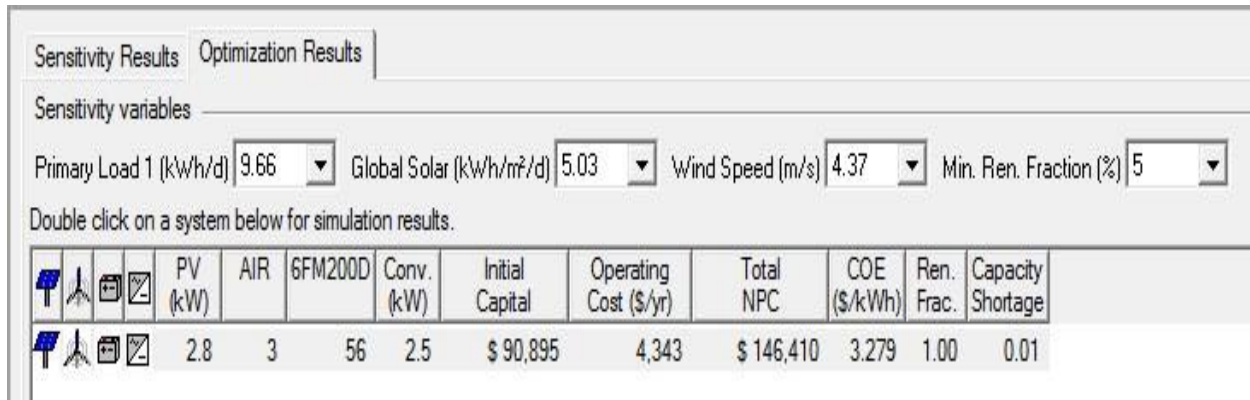

Fig. 3.17. Homer Simulation and Results.

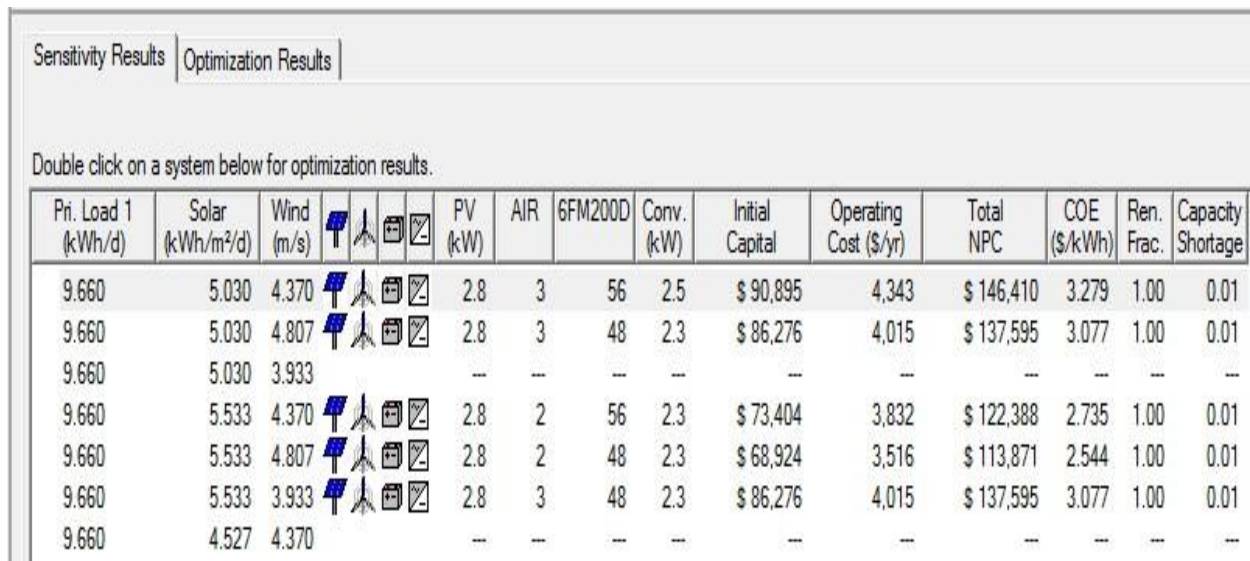

Fig. 3.18. Homer Optimization Results with Modified Sensitivities Variables

A sensitive analysis can result in a large amount of output data. Every simulation Homer performs results in many series of summary of output such as the capital cost, the total net percent cost of system and COE per kW/h. Moreover, it also indicates the result of a list showing the least cost system for each sensitivity case. From left to right, there are panels, wind turbines, batteries and the converter with a full description of each component. With

this in opinion we did sensitivity analysis using Homer. Some results are shown in Figure 3.17.

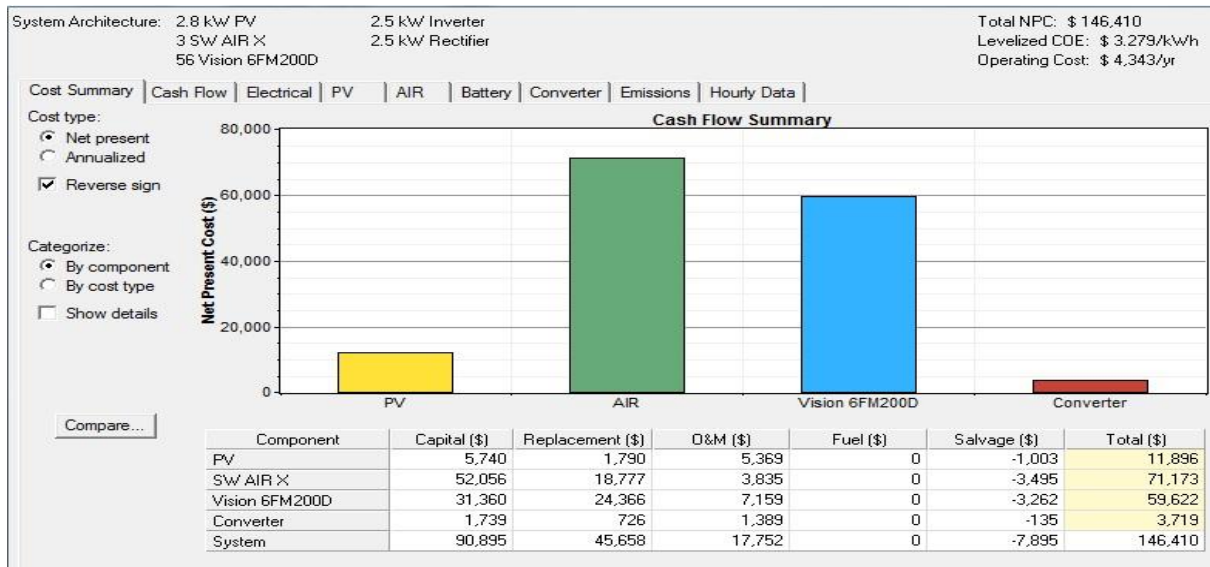

Fig. 3.19 Cash Flow Summary of Proposed Hybrid Power System of the House

Figure 3.18 above indicates the cost flow summary of 1 renewable fraction (Figure 3.16) hybrid power system. Renewable resources in Tripoli-Libya are sufficient and the house can be off-grid and most likely use bank storage of electricity to ensure the operation of the system. Such a system will result in 18.3% excess generation. This surplus can be utilized by bulbs outside on the fence of the house. The total NPC is \$146,410 and levelized COE is \$0.332kWh. The cost of operating per year is \$4,343. Because of the system age around 25 years. Means that, it will be cheaper than if it connects to the grid and insured.

Chapter 4

Electrical Details and Dynamic Simulation of Hybrid Power System

4.1 Background and Motivation

Recent years, technologies of renewable energy system are presenting the promises of clean, plentiful energy combined from self-renewing resources such as the sun, wind water, earth and plants. Also in practice, most regions around the world have renewable resources at least one of type or another. These technologies also offer significant advantages compared to conventional energy sources. It is known that energy reaches to the surface of the earth from the sun many 1000 times than is released today by all fossil fuels consumed [56]. The combination of the sustainable devices like the wind generation and photovoltaic has becoming an attractive source of energy because of their decent influence on the environment. The design of a hybrid power system that has been done in chapter three, it was consisted from wind turbine, PV, batteries, converter and ac load. The design will be simulated using MATLAB software. The results and discussion will be also presented in next pages. The major aim of this chapter is to present result with simulation model of off-grid hybrid power system and analyze its operation. This system leads to reduce the pollution. Although, it is expensive but recently their prices have been progressively dropping, and the payback period also reduces. For stand-alone off grid reduced, They can be easily set up in many reasons. For example, it can be for remote areas or/and dwellings that are far to the utility grid. In this field, there have been a few research conducts on the standalone wind-PV hybrid generation system [57].

4.2 Wind Generation Modeling using MATLAB/Simulink

The power produced by the wind generator is a DC voltage, but has variable magnitude and frequency that can then be transformed into DC-DC Boost Converter to charge the battery. The controller protects the battery from overcharging or deep discharging [58]. As high voltages, can be used to reduce system losses, an inverter is normally introduced to transform the low DC voltage to an AC voltage of 110/220 V and frequency of 50 Hz.

4.2.1 Permanent Magnet Generator

Permanent magnet generator was used. It is generally popular in newer scale turbine types. Since it enables higher efficiency in addition to smaller wind generator blade diameter. Through recent researches have considered large-scale patterns, the economics of huge values of large material has considered their use [59]. The main benefit from permanent magnet synchronous generators (PMSG) is that they do not require any external excitement current. The major cost benefit in using the PMSG is a diode bridge rectifier that may be used [60]. Some of researchers have been used the diode rectifier. This DC generator is connected to DC/DC boost converter to charge the battery and the battery connected to DC/AC inverter to feed the required load (House).

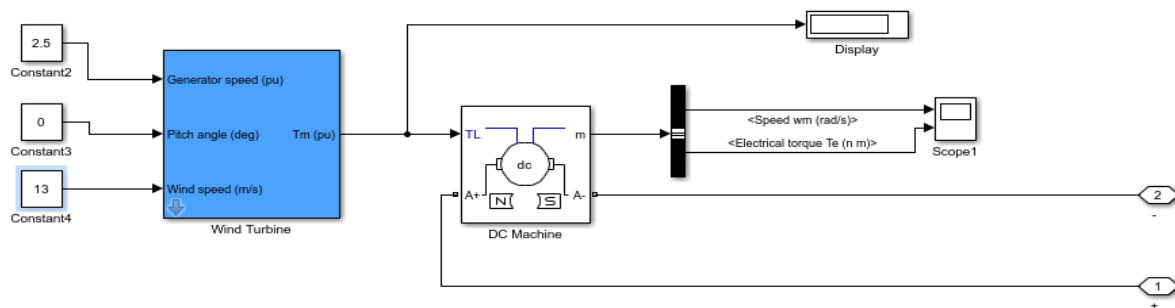

Fig. 4.1 Wind Turbine and Its Permanent Magnet Synchronous Generator

4.3 MATLAB Modeling of PV System

In this chapter, we used the MATLAB software that is becoming one of the most exceedingly used engineering software. It can be modeled, simulated, and analyzed dynamic system. Figure 4.2 shows the general block diagram of the PV model environment of Simulink as below.

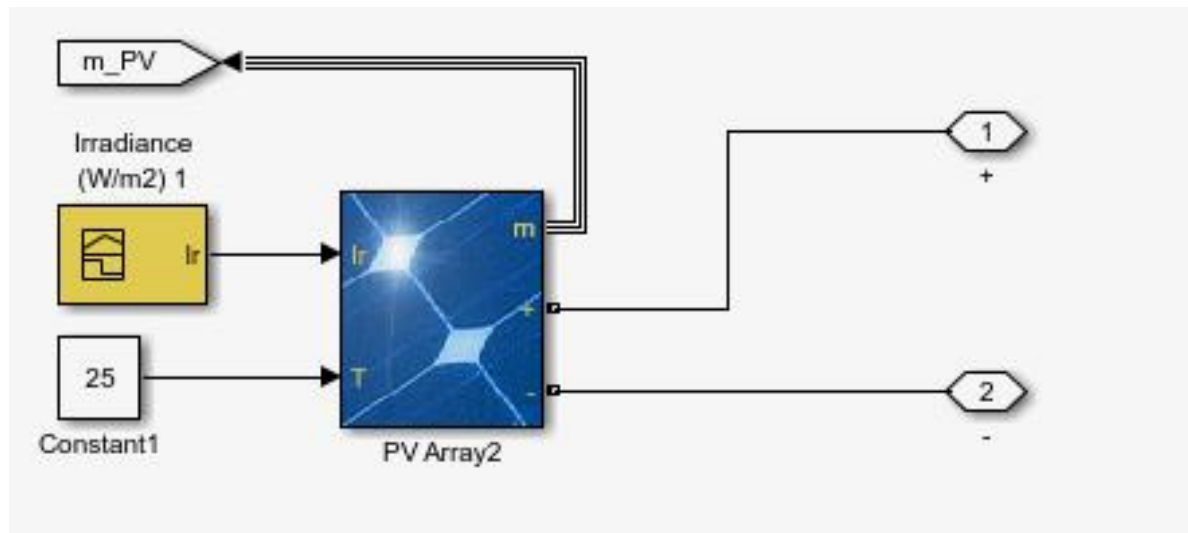

Figure 4.2 Solar PV MATLAB/Simulink Model

The figure 4.2 indicates the PV and the resource of irradiation in w/m^2 and the constant temperature ($25^{\circ}C$), it is the input side and the output side of PV. The output side is connected to DC/DC boost converter as shown in the whole system, because the input side usually is variation of the magnitude and the frequency.

4.4 The DC/DC boost converter

Boost converter is basically a step-up converter that takes in a low voltage input and supply an output at a much higher voltage. Figure 4.3 shows the diagram of an ideal dc/dc boost converter as below. Also, this type of the design of DC-DC boost converter is based on the

equations as shown below. Figure 4.3 shows the circuit inside electronics and it has also an important role in modern technology [61]. Almost in all electrical system there is at least one power converter, from mobile phone charges and computer power supplies (fast switching) and micro controllers (high frequency), power electronics becomes a main solution in renewable energy system (RES) such as PV- Wind turbines to export green power into power system with high efficiency.

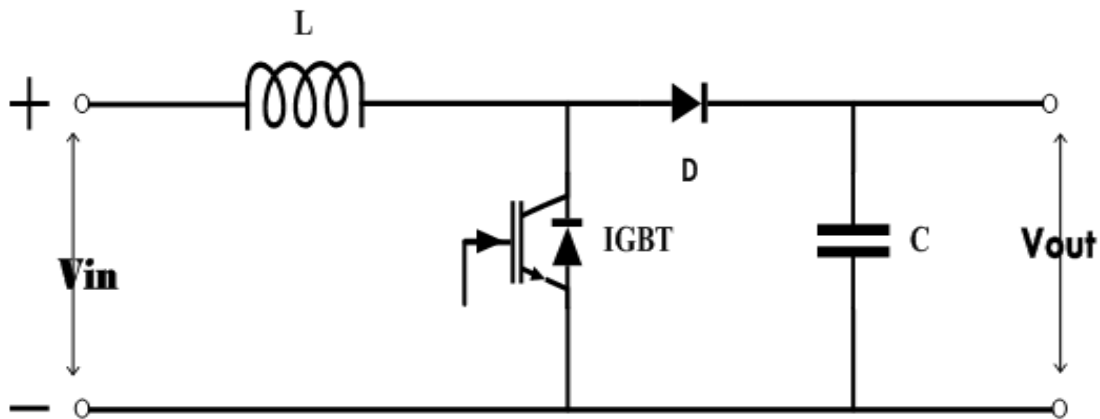

Fig.4.3 Block Diagram of DC/DC Boost Converter

$$D = 1 - \frac{V_{in}}{V_{out}} \quad (4.1)$$

$$R = \frac{V_{out}^2}{P_{in}} \quad (4.2)$$

$$L = \frac{D(1-D)^2 R}{2 * f_s} \quad (4.3)$$

$$C \geq \frac{V_{out} * D}{R * f_s * \Delta V_{out}} \quad (4.4)$$

Where, D is the duty cycle, V_{in} is the input voltage, V_{out} is the output voltage, R is the load resistance and f_s is the switching frequency. PWM controller is used to get regulated output voltage from the boost converter.

4.5 Proposed Problem

This system has two branches: a wind power generation and PV power generation. Both these devices can cover each other to some extent during the day and night; however, they have become more popular in recent years, and has become available around the world. Nowadays, we can see everywhere that a PV system is now affordable and is installed in many projects successfully. The PV system will replace batteries as its technology becomes more advanced, reliable, and safe [62]. With this growth and development, the hybrid power system will be connected to the grid or off-grid for the future. It will be better. Such a project provides energy supply, feeding, selling, and the excess power to other load and which are free emissions basically.

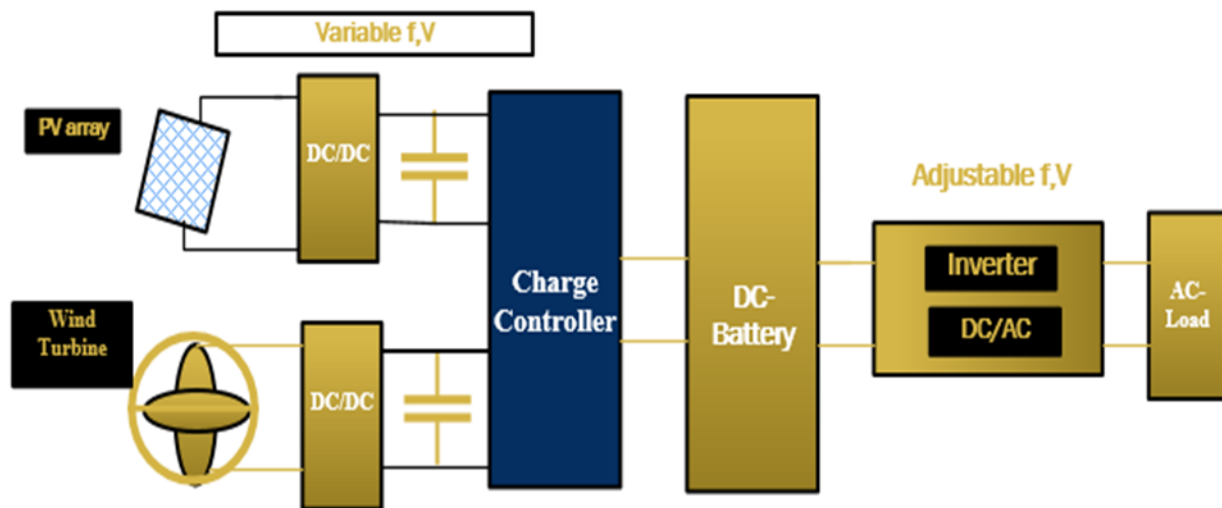

Fig.4.4 Block Diagram of Ac Shunted Load of House Connected to Hybrid PV/Wind Energy System

4.6 Modeling of Wind and PV Hybrid Power System in Mat-Lab / Simulink

For implementing a realistic hybrid energy system, we must put in account that major a theoretic study is required. This project of the study can be performed on simulation models. Also, simulation model is shown in figure 4.3 as below.

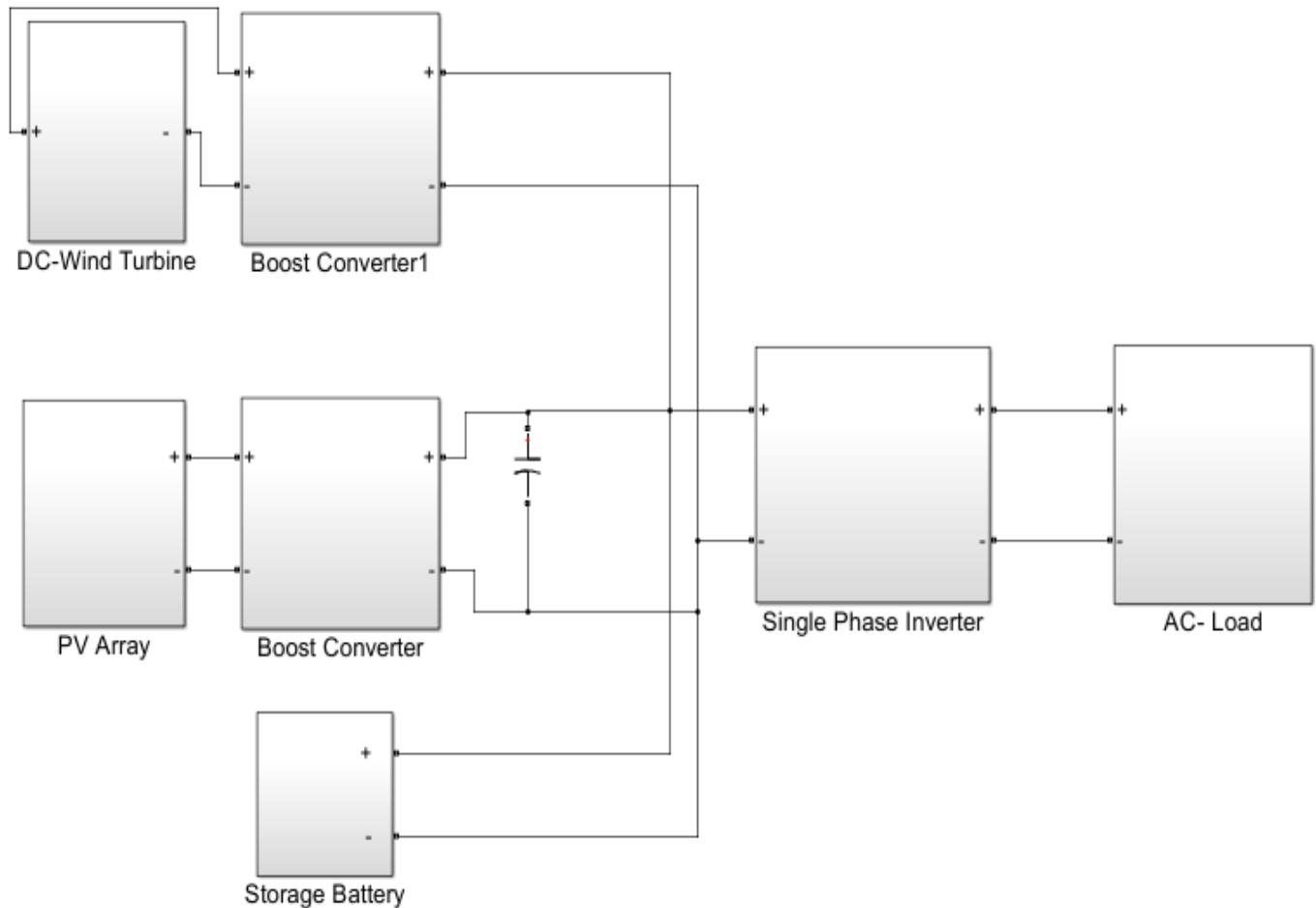

Figure.4.5 Modeling and simulation of hybrid wind-PV power generation system

4.7 Simulation Results from MATLAB/Simulink

The modeling and the simulation for the hybrid power system is used to test different conditions such as the change in wind speed, change in irradiance and the load. It is seen that the dc link voltage is maintained at a constant by the controllers for changes in the wind speed in the wind energy system and changes in irradiation and temperature in the PV system. This standalone hybrid power off-grid system for a house has two main points: first, when the load is less than generation it means the battery is charging and secondly, the load is greater than generation it means that the battery is discharging and this simulation shows how to keep the system working continuously. Figure 4.6 below shows the results of the simulation. The irradiation and the temperature of the PV system are kept constant (25°C , 1000 W/m^2). The wind speed is kept at 12 m/s. The follows figures show the relationship between t and current.

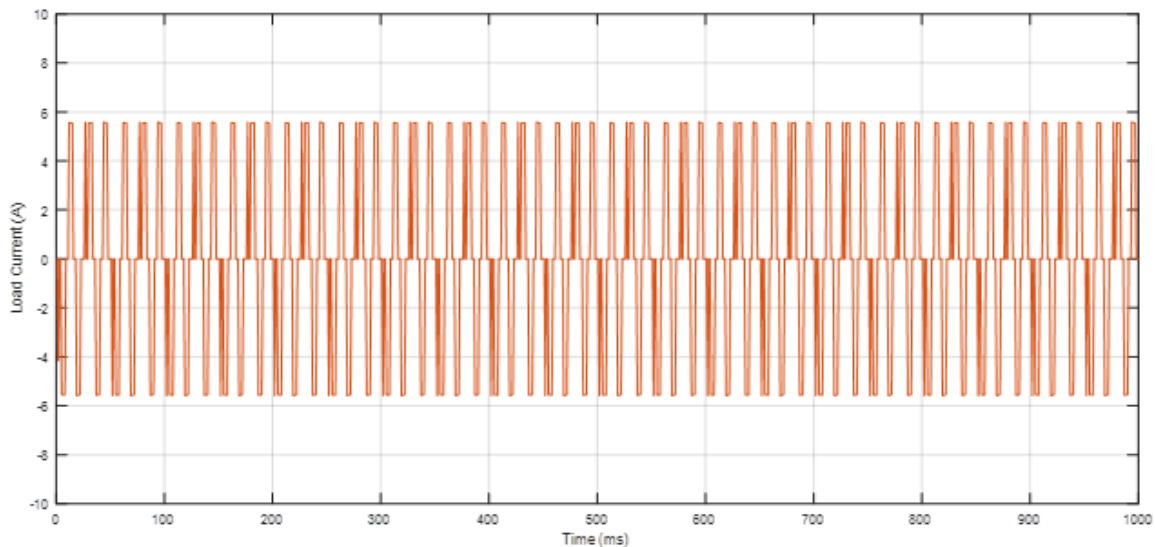

Figure.4.6 Load current (A) vs. time (m/s) in inverter

Figure 4.6 shows above the load current from the inverter. As evident from the figure we find that, load current is an ac current with an amplitude of 5.5 A with a frequency of Hz.

Figure 4.7 illustrates the inverter voltage. Like the load current inverter voltage is an AC voltage with an amplitude of 120 v and it has the same frequency of load current.

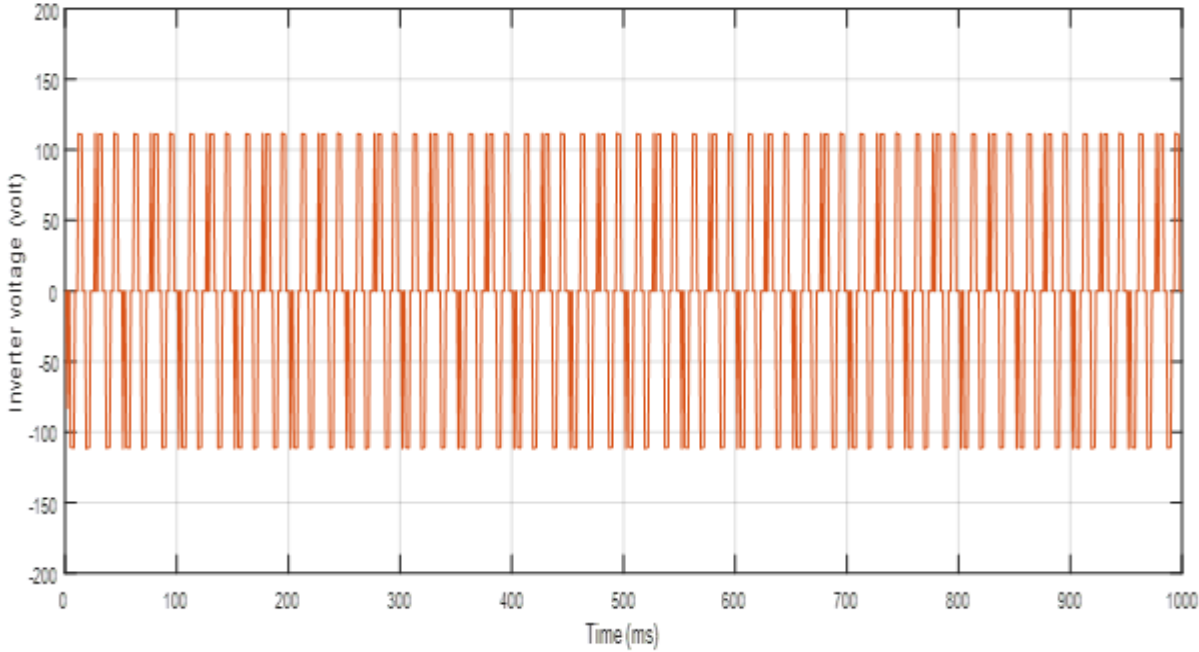

Figure.4.7 Inverter voltage vs time

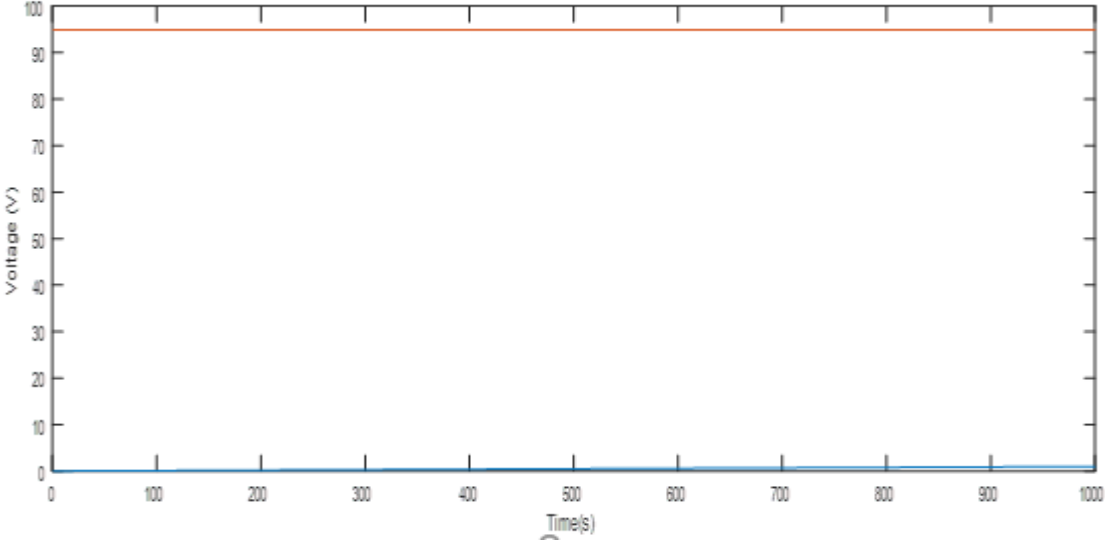

Figure.4.8 Charging Voltage of the Battery

The figure 4.8 above shows the charging voltage of the battery and its around 95% and it is in steady state. The overall, model of hybrid power system was consisted of wind turbine

connected with PMSG and photovoltaic energy system connected the boost converter and both are connected to the battery. The battery connected to the inverter and then the inverter feed the house load. This method is developed using MATLAB. AC- shunted load connection is used as interface with PWM control strategy for the VI. In addition, the dynamic performance of wind and photovoltaic power energy system are studied for different system disturbances such as load variation, wind speed variation and different irradiance inputs. The two boost converters were used to regulate the DC link voltage that comes from both, wind turbine and PV array. The simulation results show that using the controller, it is possible to have an excellent response of the load connected hybrid power system.

Chapter 5

Safety Issues, Bus Voltages and Suggestions.

In this chapter, safety issues, bus voltages, suggestions and the installation for each component such as wind resource, solar panels, converter and the battery storage will be studied and considered of the hybrid power system. There are several important factors that should take into account. For example, wind resource consideration. We need to know the annual speed, obstacles and also the prevailing directions of the wind at your site. Solar panels will be installed on the roof with no tracking system and to maximize annual electricity output its tilt angle is set equal to its latitude. In addition, the converter and the battery bank will be in the storage room on the roof to be closer to the solar panels and in a safe place.

5.1 Wind Turbine Installation

For this study and the system, the SW AIR.X 400 watts' wind Turbine has been selected. Small wind turbines used in residential applications typically range in size 400W to 20kW; it depends on the amount of electricity that you want to generate. Everything related to the wind turbine has been presented in the chapter three such as the price and other characteristics. So, the annual average wind speed is 4.366m/s for that region, means that, it can produce energy especially in between November and March and year-round energy production will be generated by solar panels because the sun resource is available over the year. The house land area is around 3000 m² and the neighbours are far away from the house about 600 m. In this case, the wind turbine will be installed beside the house with distance 20m to avoid the noise and to capture the wind as much as possible, and figure 5.1 shows the

location of wind turbine and the distance. The distance has been assumed to be 50m in order the sound of the turbine will be inaudible inside the house. But in the same time, it is necessary to install DC cable with high current specification to avoid the losses of energy.

Fig.5.1. Wind Turbine and its Location

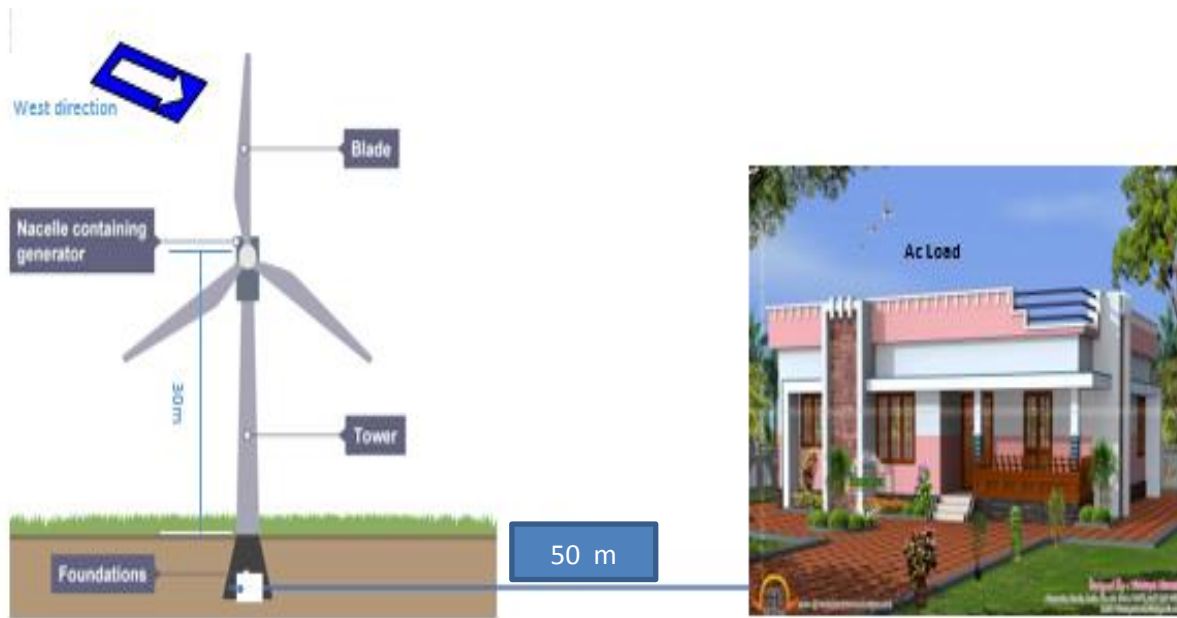

5.2 DC Power Cable Sizing

Cable sizes are predominantly important for low voltage battery cables, solar panels, and wind turbine and load cables as well. It should take in account that incorrectly sized cables often cause the voltage drops and this issue is one of the most common reasons for low voltage such as (12V, 24V, or 48V) and system faults. Moreover, if the cable is far too small, it can be very dangerous as the cable heat up and potentially cause a fire. Also, undersized cables waste energy. So, to install proper cables to your system it should consider at least three important factors those have impact on your system. The number of Amperes, the Voltage of the system and the length of the cable required. Table 5.1 shows the cables sizing

and the breakers. DC cable sizing calculator is available online [63]. For example, you enter a value for each factor and then the result shows the proper size of the cables for your system.

Table 5.1 Shows the Sizing of Cables and the Breakers

N	Cable Size	Max Fuse Breaker Size
1	6 mm ²	25 Amps
2	70 mm ²	70 Amps
3	95 mm ²	90 Amps
4	32 mm ²	110 Amps
5	150 mm ²	150 Amps

For this system, 48V-DC has been selected, because the components in this system operate with this value of voltage. Four values have been entered and calculated as 48V, 25Amps, 50 m lengths, and the percentage of cable loss acceptable usually (approximately from 2% to 3%), so the perfect cable size is 6mm. The cable cross-section should be at least 0.7 cm². It depends on how many amperes on your system draws. For 24V and 48V, the cable size will be decreased [64]. We suggest the cable size for the wind turbine and to be connected to the battery at least with 0.5cm² and with the length 50 m and connect the proper breaker as mentioned in the table. These considerations will reduce any safety issues

5.3 Solar Panels Installation

The array of the PV will be installed on the roof and will be oriented to South direction with 10 degrees' tilt in order to capture sunlight most hours of the day. For this study and the sizing that has already been done in the homer software described in chapter three, 14 PVs panels are needed. Its connection will be in parallel and series. Four PV are connected in series. Five are connected in parallel. Figure 5.2 shows the solar panels its installation on the roof and the inverter and bank batteries system will be installed in the storage room that is beside the PVs. It is necessary to keep the distance between them short in order to avoid the losses of energy. The battery bank and inverter are also kept inside the room to protect them from climate impacts such the rain in winter season and the sun's temperature in summer time.

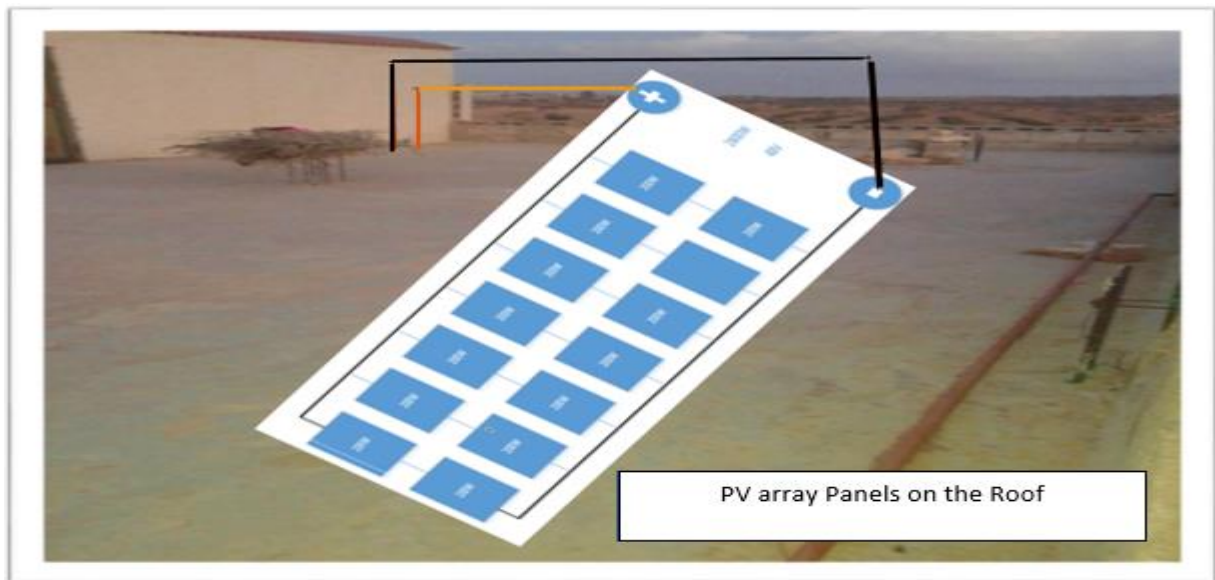

Fig.5.2. Solar Panels and its Installation on the Roof

Figure 5.2 has been taken to present the installation of the PVs panel on the roof. The project life is 25 years, no maintenance is considered.

Table 5.2 Characteristics of 200 W Mono-Crystalline PV Panels

Name	Description	Notes
Size	1580*808*35 mm	158*80.8*3.5 cm
Number of cells	36	(4*9)
Max Power	200 W	0.2 kW
Character	Waterproof	
Voltage	48V	
Cable	8m	0.6 ² cm
Nominal Capacity	200 W	
Model Number	PVM 200 W	
Frame	Aluminum	Metal, Strong aluminum allow frame
Type	Solar Panel, Film, Board	
Suitable	Aquarium Marine	
Tempered	Glass	
P max	200 W	
Vmp	36 V	
Voc	43.2 V	
Imp	5.55 A	Diode 3 by bass
Isc	6.11 A	
Working Temperature	- 40 C ⁰ to +85 C ⁰	

5.4 Battery Bank System and Inverter

To design a hybrid power off-grid system, it is important to build a battery storage bank to keep the system operating and the inverter is also a part of this system [58]. This inverter is used to transfer the voltage and the current from DC to AC (Ac load). For this design, version 6FM200D-X, 48V, and 2800Ah (20hr) was used. The bank of battery consists of 56 batteries units. They are connected in series and parallel. Each string has four batteries that are connected in series and fourteen are connected in parallel. The capacity of each battery is 200Ah, so the output is 800Ah and the voltage output is 48VDC. The battery will be protected via the charge controller. It will be installed in the same room where is the bank storage and the inverter. The battery characteristics and details are mentioned in chapter three.

Table 5.3 Characteristics of Magnum Inverter

Model	Part No	Size & Weight	Watts	Input Voltage	Output Voltage	Type	Price
Magnum Energy MS2712E	2927121	13.75*12.65*8 in	2500	48 V-DC	120 V-AC	Pure Sine Wave	1,599.20

This converter has high efficiency, simplistic for 120/230 Volt, 50 Hz applications and it is available in 12, 24, or/and 48 volt configurations in some manufactured countries such America, Europe and few countries in Africa. Magnum Energy products are known for their user-friendly design, impressive features and outstanding reliability, making this a go to off-grid inverter. The rest of characteristics are set in table 5.3 above.

5.5 Charge Controller

The purpose of the PV inverter is to convert the dc voltage from the solar array or/and the wind turbine to the ac load [65]. The better a PV inverter can adapt to the various radiations and temperature condition of the sun, the more power can be fed into the load over time, so the maximum power point tracking (MMPT) performance is a very significant factor for the PV and turbine generation system. Figure 5.3 shows the picture of the MPPT charge controller, it has several features [66]. The MPPT is used for condition when a part of solar is under shadow or parts of PV panel are damage, because it has multi crest tracing technique [66]. It can also detect out the best working point of I-V curve within 1 minute



Fig.5.3. MPPT Charge Controller [67]

Its efficiency could reach to 99.9%. The other feature is with current-limiting charging mode. When the power of solar panel is oversized, the controller will lower charging power automatically, which can the system to work under the rated charging current [67]. In addition, various load control methods. It could recognize day and night automatically [67].

5.6 Safety Issues and the Suggestions

When we design such a hybrid off-grid power system, safety must always be our main concern pending the assembly, installation and operation of our leading-edge turbines (WTs) and proper charge controller. Our suggestions for this system will be presented as the following steps [68].

- Proper cables sizes that are matching to the all components of the system to avoid the voltage dropping.
- We also suggest the cable that is connected between the wind turbine and the battery has to be buried in ditch inside the PVC pipe (polyvinyl chloride). The reason is to protect it from the Climatic conditions.
- Follow the standard specification of electric for the generic wiring diagrams.
- The units such as the batteries, charge controllers and inverters have to be mounted in sufficiently ventilated area that is not exposed to moisture or any type of spray. So, these devices will be installed in room on the roof of the house to be in safe place and close to the PV panels.
- Use the correct voltage controller. For example, a 12V charge controller should only be used on a 12V battery system and etc. In other words, do not match the 24V wind turbine or 12V PV photovoltaic to 12V batteries.
- Painting the roof by light color to reflect the sunlight in order to decrease the temperature degrees around the PV array.

- Obviate using undersized cables and/or insufficient diameters between solar panels and solar regulator because it occurs excess heat generation. Similar situation will occur when connect the deep cycle battery and the appliances using Inappropriate cables. This is not only loss electricity it is also known as line loss and can cause lights fainting and unexpected equipment shutdowns.
- Proper sub-circuit breakers for each device. Main circuit breaker is needed in order to protect the whole system.

Chapter 6

Conclusion

Overall, this thesis has presented an optimal design and analysis of a net-zero energy houses and its power system for Libya. For this aims, we have used two kinds of different software to estimate residential design and thermal analysis. The first software was used; it is called BEopt (Building Energy Optimization). We designed the house twice using BEopt. The first one was the conventional house un-insulated, and the second one was using new parameters such as the insulation for the walls and the roof in order to achieve the desired goal which is a net-zero energy dwelling. Both cases, the energy consumption has been reduced approximately 54.875% from the total energy consumption of the house. The second software is Energy 3D software, it was used to calculate energy consumption for that house, and the reduction of energy consumption has been achieved by 25.557%. With these modern technologies, we can save the energy and make the comfortable indoor environment as well as alleviate the Carbon emissions with saving money respectively. Moreover, with a small load of the house, we have designed the hybrid power off-grid system to produce a power to meet the required load of that dwelling and the hybrid energy system is combined using solar panels, wind turbine, and battery storage as backup for few days. It has presented in the chapter three. In this thesis, also a wind turbine, solar and battery storage hybrid power system for generation energy system is modeled and simulated on MATLAB software. From the simulation result, it has been observed that simulation for different cases when the days are sunny, windy and rainy it has been found to be effective to supply the proposed power demand with high level of performance of the system to continue of supplying constant power.

6.1 Contribution

The main contribution from this thesis was to provide the optimal design of a net zero-net energy and thermal analysis of the dwelling using three types of software tools. Various investigations were carried out to support the results discussed in the chapter two. Reaching of this approach, several tools were used that help the users to save energy, their money and making comfortable environment indoor. A comparative between several design and analysis of a net-zero energy dwelling have been presented in chapter two; all results showed that the energy has been reduced most likely 50% of the total amount that the house was consumed from the grid. Also, the results of the investigations in Chapter 2 were published at a local (IEEE, The Twenty-Fifth Annual Newfoundland Electrical and Computer Engineering Conference, 2106). Also, this presented in different conference, it was in ICCE 2016: 5th International Conference & Exhibition on Clean Energy August 22-24, 2016 McGill, Montreal, Canada. In chapter 3, the major point of this is to sizing a hybrid generation system that was consisted from wind turbine, PV panels and battery storage to provide an electric power to meet the required load of the house after the power reduced to about half of the total energy as presented in previous chapters. To design such this system, first important factor should be known which the load is. In other word, the optimal configuration system can be achieved. Also, the results and discussed in chapter 3 were publish at international IEEE, (2016 IEEE 7th Annual Information Technology, Electronics and Mobile Communication Conference (IEMCON). Chapter 4 has showed the behaviour for each component of the design a hybrid power system using the MATLAB/ Simulink and the results are presented in that chapter.

6.2 Recommendations for Future Research

The aim to achieve cost effective net-zero energy dwelling is restrained by cost itself. But, in the same time it is a terrified task to figure out the optimal cost effective saving energy for designated location. Net-zero energy houses is an outset to provide better instructions and suitable guidance for design and analysis of a net-zero energy to deliver it in hot climates. Nowadays the tools have already become available to use in this field. In contrast, the designers will still require more information in order to make informed decision. Also for best utility of use, the tool can include a completely visible input interface and allow the users to add new building model for new houses types or case studies. This approach can have many kinds of shapes. For example, T shape, H shape and U shape with different envelope types. Moreover, the scope of the tools and using the advanced technologies, this can be expanded further to achieve the NZEH objective for existing houses or on a major scale (neighbourhood or community). Libya country has quite enough green resources those can be utilized to contribute in a part of providing electricity power which is helping to save the energy usage in the buildings and make the clean environment. The suggestion is to transfer these ideas and the studies to that region. The challenges are still stand-alone because the lack of experts and engineers who are interested whether the engineers who work in electrical general company in Libya or even who teach in Universities as professors. This concern has been raised due to global warming that caused by carbon dioxide emissions which is came from the building energy usage that still depends on the conventional resources. We hope to see this technology there and to be understood to utilize in our daily life. In addition, some techniques are played significant role such as form of building and orientation. Daylight gaining - examine cost- effective ways to spread top-lighting and side-lighting. It can be

achieved by proper windows. Window area - Investigate optimal window areas for the combined impact on heating, cooling and delighting.

References

- [1] H. J. Christina and G. L. Fried, "Multi- criteria decision making under uncertainty in building performance assesment," *Building and environment*, vol. 69, pp. 81-90, November 2013.
- [2] V. Delise and S. A. M, "Net-zero energy house: Solar photovoltaic electricity scenario analysis based on current future costs,," *Ashrea conference, Monterial* , June, 25- 29 2011.
- [3] S. S. Ravi, B. William and D. P. Campbell, *Proceedings of the 2011 Winter Simulation Conference*, pp. 3365-3377, January 2011.
- [4] A. S. Amonto, "Law Qatar's first Passivehaus on track for 2013 completion, <http://www.greenprophet.com>," Novmber 8 2012, 2013.
- [5] M. A. Nancy and Nabb, "Strategies to Achieve Net-Zero Energy Homes: A Framework for Future," *NIST Special Publication 1140*, pp. 1-51, April 2013.
- [6] W. O. Brien and T. Kesik, "Solar Design Days: A tool for passive solar house design," *Available on line*, pp. NY-14-009, February 10 2014.
- [7] L. L. Pertz and O. Jose, "A review on buildings energy consumption information," *Energy and building 40*, pp. 394-398, March 2008.
- [8] R. Charon and A. Athienities , "Design and optimization of net zero energy solar home," *Published in ASHREA Transactions*, vol. 112, June 2005.
- [9] L. Zhu, R. Hurt b and D. Correia , "Detailed energy saving performance analyses on thermal mass walls," *Published at Energy and Buildings 41 (2009)*, p. 303–310, October5 2008.
- [10] J. Charap , "Libya: Selected Issues," © 2013 *International Monetary Fund*, p. No. 13/151, May 2013.
- [11] M. Nachmany, . F. Sam and N. Kingsmill, "The 2015 Global Climate Legislation Study A Review of Climate Change Legislation in 99 Countries," www.lse.ac.uk/GranthamInstitute/wp-content/uploads, pp. 1-5, 2015.
- [12] "Monthly Energy Review," *DOE/EIA-0035, Released: November 22, 2016*, p. Book, November 2016.

- [13] R. Chudley and R. Greeno, "BUILDING CONSTRUCTION HANDBOOK," *Seventh edition*.
- [14] P. McKeen and A. S. Fung , "The effect of building aspect ratio on energy efficiency: A case study for multi-unit residential buildings in Canada," *buildings ISSN 2075-5309*, pp. 336-354, June25 2014 /.
- [15] A. Wilson, "Environmental Building News,The leading newsletter on environmentally responsible design & construction," *A Publication of BuildingGreen, LLC*, vol. 19, p. 6, Number 6 2010.
- [16] G. Seyfang, "Communityactionforsustainablehousing:Buildingalow-carbonfuture," *The International Journal of the Political, Economic, Planning, Environmental and Social Aspects of Energy*, p. 7624–7633, 2010.
- [17] L. Wang, J. Gwilliam and p. Jones, "Case study of zero energy house design in UK," *Energy and Buildings 41*, p. 1215–1222, 2009.
- [18] M. E. Student and V. Malkapur, "Review on design & simulation of multi stage converter for hybrid Wind-PV system," *presented at EISSN: 2250- 0804*, vol. 5 Apr- , p. No.2, June 2015.
- [19] A. Athienitis, *Published in ASHRAE Transactions*,, vol. Volume 112, p. Part 2, 2006.
- [20] E. I. A. U.S, "International energy outlook 2016 buildings sector energy consumption - energy information administration," *U.S ,EIA Orgnization*, pp. Chapter 6, Report Number: DOE/EIA0484(2016) , May 11, 2016.
- [21] M. W. Smith, . P. A. Torcellini and . S. J. Hayter, "Thermal performance analysis of a high-Mass residential building," *presented at the American Solar Energy Society, (ASES) Forum 2001* , pp. 1-5, April 21-25, 2001.
- [22] N. Ekramia, A. Garatb and A. S. Funga, "Thermal Analysis of Insulated Concrete Form (ICF) Walls," *The 7th International Conference on Applied Energy – ICAE2015*, vol. Energy Procedia 75 , p. 2150 – 2156 , 2015.
- [23] . M. Tunzi and R. Boukhanouf, "A Carbon Neutral Small Scale District Heating," *Presented at 14th International Conference on Sustainable Energy Technologies*, August 2015.
- [24] S. T. Elias, F. Summers and . N. Surmeli, "A comparative study of the thermal performance of building materials," *The 23rd Conference on Passive and Low Energy Architecture, Geneva, Switzerland*, pp. 1-6, September, 2006 .
- [25] B. Anderson and B. Scotland , "Conventions for U-value calculations,2006 edition," *BRE*

publications are available on www.brepress.com, pp. 1-44, 2006.

- [26] T. O. A. Orgnization, "Ashrea HandBook- Fundamentals," <http://www.toollending.com/UCBxweb/homework/ASHRAE%20tables.pdf>.
- [27] W. S. F. U. D. O. E. Charles Eley Associates supporting, "Passive solar design strategies: guidelines for home Building," *National Renewable Energy Laboratory* , pp. 1-87 book, 2010.
- [28] <https://greenpassivesolar.com/>, "Green Passive Solar Magazine," *Highlighting the sustainable, renewable, green building technologies of passive (and active!) solar design*, July 20, 2011.
- [29] R. Yumurtac, Role of energy management in hybrid renewable energy systems: case-based analysis considering varying seasonal conditions, Istanbul : Turkish Journal of Electrical Engineering & Computer Sciences, 2013.
- [30] Y. C. Kim and SpringerLink, Design and Management of Energy-Efficient Hybrid Electrical Energy Storage Systems, Book, 11 July 2014.
- [31] O. K. Ali and H. Noorazuan, Changes in residential land-use of Tripoli city, Libya: 1969-2005, *Malaysian Journal of Society and Space* 4, 2008.
- [32] K. I. Elfadli, Precipitation Data of Libya, Tripoli, 01 Septembe,2009.
- [33] B. Belgasim and M. Elmnefi, Evaluation of a Solar Parabolic Trough Power Plant under Climate Conditions in Libya, Geneva: 13th International Conference on Sustainable Energy technologies,25-28th August, 2014, 2014.
- [34] A. M. Kassem, . K. Sayed and . E. El-Zohri, "Sizing of Hybrid PV/Battery Power System in Sohag city," *Journal of Electronics and Communication Engineering (IOSR-JECE)*, vol.10, no. Issue 6, pp. 63-70, Nov - Dec .2015.
- [35] P. B. E. STAFF, "Renewable Energy Potential In Libya | Afribiz.info," *26th Annual Energy Storage Conference*, pp. 1-7, April4/13/2016.
- [36] I. C. R. N. 13/151, "Libya: Selected Issues," *2013 International Monetary Fund, publications@imf.org*, pp. 1-14, May 2013.
- [37] A. Khalil and A. Asheibi, "Solar energy is believed to be the most important and feasible renewable energy source in Libya," *Conference: Workshop on Reconstruction of the University of Benghazi, 30-31 Jul 2016, Benghazi, Libya.*, pp. 1-15, July 2016.
- [38] X. Roboam and I. Ebrary, "Systemic design methodologies for electrical energy systems

- analysis, synthesis and management," *Wiley series in electrical and computer engineering*), Hoboken London, 2012.
- [39] N. R. E. Laboratory, "HOMER Help Manual," *Avialable online: file:///C:/users/jonathan/documents/HOMER_help/HOMERManual_SourceCode_output/Single HTML/HOMER.htm*, pp. 1-241, 1/16/2015 .
- [40] N. Staff, "NASA Atmospheric Science Data Centre, NASA," *Available from: http://eosweb.larc.nasa.gov/*, Last Accessed 5th March.
- [41] . M. Brower, . B. . E. Bailey and Books 24x7, "Wind resource assessment a practical guide to developing a wind project.," *Book, Hoboken, NJ 07030-5774 ; London*, (2012).
- [42] . S. Krohn and D. W. T. M. A. , "Guided tour on wind energy, Book," *Copenhagen : Danish Wind Turbine Manufacturers Association*, pp. 1-367, June 29th,2000.
- [43] Fox, Brendan , Bryans, Leslie, Jenkins and Nicholas, "Wind Power Integration Connection and system operational aspects, 2nd Edition," *The Institution of Engineering and Technology*, no. 1 online resource (319 p, p. Book, 2014).
- [44] T. Ackermann, A. Ellis and J. Fortmann, "Code Shift: Grid Specifications and Dynamic Wind Turbine Models," *I E E E Power & Energy Magazine*, vol. 11, no. 6, pp. 72-82, No. 8, 2013.
- [45] . Ningsu, . Yolanda and L. Acho, "Modeling and Control of PMSG-Based Variable-Speed Wind Turbine," *Book, Available online*, pp. 3-21, August31, 2014.
- [46] ©. 2. W. S. U. E. E. Program, *Solar Electric System Design, Operation and Installation An Overview for Builders in the Pacific Northwest, Washington State: book*, October,2009.
- [47] C. 2. R. P. P. Ltd., "Solar Photovoltaic Power System Handbook Grid Connected System," in *Regen Sustainable Power Solution* , Sydney , 2011, pp. 1-22.
- [48] F. Dincer and . M. E. Meral, "Critical Factors that Affecting Efficiency of Solar," *Smart Grid and Renewable Energy*, no. 1, pp. 47-50, May 2010, Available online (<http://www.SciRP.org/journal/sgre>).
- [49] S. . A. Chen, V. Arun and . S. Saket, "Shedding Light on the Performance of Solar Panels: A Data-Driven View," *Newsletter ACM SIGKDD Explorations Newsletter*, vol. 17, no. Issue 2, pp. 24-36, December 2015.
- [50] G. O. researchers, *Battery Storage for Renewables: Market Status and Technology Outlook, Countries around the world: IRENA, International Renewable Energy Agency*, January 2015.

- [51] . R. Nagaraj, D. Thirugnanamurthy and M. Rajput , "Techno-economic analysis of hybrid power system sizing applied to small desalination plants for sustainable operation," *International Journal of Sustainable Built Environment*, vol.5, no. 2, pp.269-276, December 2016.
- [52] C. umitrescu and . M. Popescu, "UPS Voltage Stabilization by Boost Converter Implementation," *Electrotehnica, Electronica, Automatica*, vol.64, no. (2), pp. 71-75, Apr-Jun 2016.
- [53] Unnkown, "Which solar charge controller: PWM or MPPT?," in *Unknown*, Victron Energy B.V. | De Paal 35 | 1351 JG Almere | The Netherlands ,<https://www.victronenergy.com/>, 28 June 2014, pp. 1-14.
- [54] S. Amber , A. Ersuel and K. Steven , "Photovoltaic MPPT Charge Controller," Florida, Sponsored by Workforce Central , Fall 2011, pp. 1-153.
- [55] . G. R. Srinivasa , "Dynamic simulation of hybrid wind-diesel power generation system with superconducting magnetic energy storage," *Energy Conversion and Management,Source: OAI*, vol. 38, no. (4), pp. 246-246, Jun 9, 2016.
- [56] S. C. TRIPATHY , k. M and R. . B. , "Stability Simulation and Parameter Optimization of Hybrid Wind Diesel Power Generation System," *International Journal of Energy Research*, vol. 16, pp. 31-42, 1992.
- [57] D. Pop, T. Radu and . N. Liviu, "Modeling and simulation of a small wind turbine using Matlab Simulink," *Carpathian Journal of Electrical Engineering*, vol. 7, no. (1), pp. 31-37, 01 December 2013.
- [58] J. T. Uk, "Electromagnetic design analysis and performance improvement of axial field permanent magnet generator for small wind turbine," *Proceedings Of Journal of Applied Physics.The 55th Annual Conference On Magnetism And Magnetic Materials, Atlanta, Georgia*, vol. 111, no. (7), 14-18 November 2010.
- [59] J. U. Tae and C. S. Jun, "Electromagnetic Structural Design Analysis and Performance Improvement," *Journal of Magnetism*, vol. 16, no. (4), pp. 374-378, 20 December 2011.
- [60] . H. Al-Sheikh and G. Hoblos, "A Sensor Fault Diagnosis Scheme for a DC/DC Converter used in Hybrid Electric Vehicles," *IFAC Papers OnLine*, vol. 48, no. (21), pp. 713-719, 2015.
- [61] G. J. Faxas , . R. Fernández and J. Antonio , "Longer battery lifetime provided by a priority load control algorithm on stand-alone photovoltaic system," *Journal of Renewable and Sustainable Energy*, vol. 7, no. (1), pp. 1-1, January 2015.

- [62] . R. . N. Abdul H and M. A. Omar, "Modeling of a maximum power point tracker for a stand-alone photovoltaic system using MATLAB/Simulink," *International Journal of Low-Carbon Technologies*, vol. 9, no. (3), pp. 195-201, 2014.
- [63] ., N. Kumar, . C. . P. Panchariya and . K. Srinath, "Hybrid mine wide communication system for surveillance and safety of the miners in underground coal mines," *International Conference on Advanced Electronic Systems,IEEE*, pp. 262-266, Sept. 2013.
- [64] A. R. N. H and . M. . A. Omar, "Modeling of a maximum power point tracker for a stand-alone photovoltaic system using MATLAB/Simulink," *International Journal of Low-Carbon Technologies*, vol. 9, no. (3), pp. 195-201, 2014.
- [65] S. Ahmad, H. Wan and . Z. Mohd , "Alternative Solar-Battery Charge Controller to Improve System Efficiency," *Applied Mechanics and Materials*, vol. 785, pp. 156-161, Aug 2015.
- [66] R. Djamila and M. Ernest, "Optimization of Photovoltaic Power Systems: Modelization, Simulation and Control," *Springer London, London* , London 2012.
- [67] T. A. AzadehNazari and H. Charkhand, "Optimisation of facility layout design problem with safety and environmental factors by stochastic DEA and simulation approach," pp. 1-20, 17 December 2014.
- [68] S. Amber , "Photovoltaic MPPT Charge Controller," in *Photovoltaic MPPT Charge Controller*.