



Stage Technology in Modern China: The Media of Revolution and Resistance

The Harvard community has made this article openly available. [Please share](#) how this access benefits you. Your story matters

Citation	Chun, Tarryn Li-Min. 2016. Stage Technology in Modern China: The Media of Revolution and Resistance. Doctoral dissertation, Harvard University, Graduate School of Arts & Sciences.
Citable link	http://nrs.harvard.edu/urn-3:HUL.InstRepos:33840693
Terms of Use	This article was downloaded from Harvard University's DASH repository, and is made available under the terms and conditions applicable to Other Posted Material, as set forth at http://nrs.harvard.edu/urn-3:HUL.InstRepos:dash.current.terms-of-use#LAA

Stage Technology in Modern China: The Media of Revolution and Resistance

A dissertation presented

by

Tarryn Li-Min Chun

to

The Department of East Asian Languages and Civilizations

in partial fulfillment of the requirements

for the degree of

Doctor of Philosophy

in the subject of

East Asian Languages and Civilizations

Harvard University

Cambridge, Massachusetts

May 2016

© 2016 - Tarryn Li-Min Chun
All rights reserved.

Stage Technology in Modern China: The Media of Revolution and Resistance

Abstract

This dissertation examines how the introduction of new stage technologies—from electric spotlights to live-feed digital cameras—into modern Chinese theater has shaped dramatic text, performance practice, and artistic theory from the 1930s to the present. Extant scholarship on modern Chinese performing arts acknowledges the importance of technical elements like scenography and lighting, but generally treats such elements as secondary to the artistic labors of actors, directors, and playwrights. In contrast, my study foregrounds the material and medial components of live performance and demonstrates that they are in fact central to both the aesthetics and politics of modern theater in China. Using a methodology that combines literary and performance analysis, I argue that the modernization of the stage apparatus in China has propelled a reconceptualization of drama *as* a technology in the service of political and ideological goals. Yet, at the same time, the very technologies that have facilitated this shift also have galvanized aesthetic innovation, enabled new forms of critique, and connected Chinese dramatists to global trends in theater arts.

The project is structured around periods of innovation in modern Chinese theater, examined through specific performance case studies: lighting in early spoken drama (1930s), architecture and political theater (1950s), the body as anti-technology in “little theater” (1980s), and new media in avant-garde performance (2010s). For each case, I use sources such as literary texts, technical drawings from theater periodicals and archives, memoirs and essays by theater artists, and interviews with living directors and designers to reconstruct the real and imagined material conditions of performance at distinct historical moments. These materials enable me to

examine the intersection of technology and theater on three interrelated levels: how practical advances influence the writing (or adaptation) of scripts and facilitate production; how conceptual innovations refashion the craft of performance; and how human agents mobilize in service of (or against) the stage apparatus. Together, these cases demonstrate that the entanglement of technology, performance, and politics has been and continues to be a defining force in the development of Chinese theater.

Table of Contents

List of Illustrations.....vi	
Acknowledgments.....viii	
Note on Romanization and Translation.....xi	
Introduction.....	1
Setting the Stage	3
Terminology	10
Literature Review	15
Chapter Outline	22
Chapter 1 Technical Difficulties.....	26
<i>Roar China!</i> and China	29
Mobilizing Technical Critique Onstage	44
The Revolutionary Potential of Technical Theater	56
Scripting Technology as Dramaturgical Mode	72
Chapter 2 Socialist Special Effects.....	83
Socialist Theater Construction in the Early PRC	86
<i>Guan Hanqing</i> (1958) as Monumental Theater	106
Theory and Practice of Great Leap Theater	114
<i>Guan Hanqing</i> Beyond Beijing	131
Modeling the Modern World	140
Interlude Performance as Technology.....	151
Chapter 3 Multimedial Actors.....	173
Science and Technology in Content and Form	176
Rehabilitating the Actor's Preparations	184
Technique and Technology in <i>The Red Nose</i>	193
Staging Process in Little Theater	209
Re-Production Manuals	218
Chapter 4 The Aesthetics of Technological Excess.....	228
New Trends in Technology and the Arts	232
Generation XXX: Wang Chong and Technology Critique	246
Feng Jiangzhou and the Art of Noise	268
Technical Familiarization	283
Conclusion.....	298
Bibliography.....308	

List of Illustrations

Figure 1	Cover of <i>Play</i> journal; set designs by Zhang Yunqiao (1933).....	27
Figure 2	<i>Roar, China!</i> photo collage published in <i>Liangyou huabao</i> (1933).....	34
Figure 3	Illustration from <i>Life Magazine</i> (1930).....	41
Figure 4	Set designs by Zhang Yunqiao, published in <i>Play</i> (1933).....	42
Figures 5-6	Production photos from Theater Society performances (1933).....	43
Figure 7	Scene-by-scene stage diagrams with lighting equipment (1933).....	45
Figure 8	Photograph of lighting equipment (1927).....	60
Figure 9	The Roxy Theater, as depicted in <i>Theater Studies Monthly</i> (1933).....	63
Figure 10	“Tools of the Modern Stage” in <i>Theater Studies Monthly</i> (1933).....	63
Figure 11	Liquid dimmer, as depicted in <i>Resistance Drama</i> (1939).....	65
Figure 12	“The Technologization of the Stage” in <i>Small World</i> (1934).....	70
Figure 13	Tianqiao Theater, Beijing.....	94
Figure 14	Capital Theater, Beijing.....	101
Figure 15	Renderings of the 3000-seat National Theater.....	105
Figure 16	Guan Hanqing image by Li Hu, here pictured in the Great Hall of the People..	111
Figure 17	Diao Guangtan as Guan Hanqing for the 1958 BPAT production.....	132
Figure 18	Gao Zhongshi as Guan Hanqing for the 1958 SPAT production.....	132
Figure 19	<i>Guan Hanqing</i> neon sign, Yangtze Theater, 1958.....	136
Figure 20	Zhu Lianxiu (played by Dan Ni), <i>Guan Hanqing</i> , SPAT, 1958.....	137
Figure 21	Set design, <i>Guan Hanqing</i> , SPAT, 1958.....	138
Figure 22	Production photograph, <i>Guan Hanqing</i> , SPAT, 1958.....	138
Figure 23	Cover of production manual for <i>The Red Lantern</i> (published 1970).....	159
Figure 24	Lighting plot for <i>The Red Lantern</i> (1970).....	160
Figure 25	Red lantern prop design for <i>The Red Lantern</i> (published 1970).....	161
Figure 26	Choreography from <i>Red Detachment of Women</i> production manual (1970)....	163
Figure 27	Set design for Youth Arts Production of <i>The Red Nose</i> (1982).....	198
Figure 28	Blocking and stage directions for added scene in <i>The Red Nose</i> (1982).....	202
Figure 29	Blocking and stage directions for Act 3 in <i>Thunderstorm</i> (1979).....	220
Figures 30-33	BPAT <i>Thunderstorm</i> productions.....	224
Figures 34-35	<i>Thunderstorm 2.0</i> by Théâtre du Rêve Expérimental (2012).....	255
Figures 36-37	<i>Thunderstorm 2.0</i> by Théâtre du Rêve Expérimental (2012).....	256
Figure 38	Publicity photo from <i>Thunderstorm 2.0</i> (2012).....	258
Figure 39	<i>Ibsen in One Take</i> by Théâtre du Rêve Expérimental (2013).....	264
Figure 40	<i>Ibsen in One Take</i> by Théâtre du Rêve Expérimental (2012).....	264

Figure 41	<i>Ghosts 2.0</i> by Théâtre du Rêve Expérimental (2014).....	265
Figure 42	<i>Ghosts 2.0</i> by Théâtre du Rêve Expérimental (2014).....	267
Figure 43	<i>Eight Sounds</i> by Feng Jiangzhou (2007).....	274
Figure 44	Swirling projected characters, <i>Encore Mount Wutai</i> (2014).....	282
Figure 45	Illuminated panel onstage, <i>Encore Mount Wutai</i> (2014).....	282
Figure 46	Environmental multimedia in <i>Looking for Courage</i> (Denmark, 2015).....	295
Figure 47	Choreography from <i>Victory and Peace</i> (2015).....	299
Figure 48	<i>Roar, China!</i> woodcut by Li Hua (1936).....	299
Figure 49-50	<i>The Revolutionary Model Play 2.0</i> (2015).....	300

Acknowledgements

First, I would like to thank the members of my dissertation committee for their unwavering support and guidance throughout the process of imagining this project and bringing it into being. Professor David Der-wei Wang has had the perspicacity to see my arguments at a distance, even while I remain mired in my materials, and the patience to wait for me to find them in my own way and time. Professor Wilt L. Idema has taught me everything I know about premodern drama, the importance of meticulously checking my sources, and the value of taking a well-timed break to see a movie or some musical theater. Professor Martin Puchner has met many a messy draft with the perfect mix of provocative questions, sound advice, and kind encouragement to preserve. Professor Jie Li has provided me with a model for rigor, integrity, and passion in her scholarship, and I would not have half a dissertation without our many stimulating conversations. Any oversights or errors remaining after their comments and corrections are mine alone.

Research for my project was supported by generous grants from the Center for Chinese Studies at National Central Library in Taipei, the Shanghai Theater Academy, and the Fairbank Center for Chinese Studies at Harvard University. In my final years at Harvard, the support of a merit fellowship from the Edwin Curley Fund and a GSAS Dissertation Completion Fellowship provided support for the writing of this dissertation.

In mainland China, I am indebted to colleagues at the Shanghai Theater Academy (STA), Shanghai Dramatic Arts Center, Central Academy of Drama, Beijing People's Art Theater, and Nanjing University. I owe a special thanks to Professor Ye Changhai at STA for encouraging me to apply for the grant from STA that enabled me to travel to Shanghai in winter 2013 to gather

archival material, and to Fei Yong for help with logistics and many stimulating conversations. With apologies for omissions, I would like to thank William Huizhu Sun, Yu Rongjun, Ma Junshan, Dong Jian, Lu Xiangdong, Zhang Fuhai, Liu Xinglin, Wang Xiang, and the many other artists and scholars who helped me during my fieldwork. My thanks especially to Li Chang, Wang Chong, Feng Jiangzhou, Alison Friedman, and Oda Fiskum for speaking with me formally and informally about their work and the state of the arts in China today.

Taiwan will always have a special place in my heart. I am grateful to the Center for Chinese Studies for enabling me to return for a semester in Spring 2014 and providing me with a place to work and share my research. I would also especially like to thank Hsin-hsin Tsai and Katherine Hui-ling Chou for giving me grand tours of the theater world in Taiwan. Hsin-hsin laoshi never fails to take care of me when I visit and has fed my love of *gezaixi*; KC has made me a true part of the BlackBox Theater family at National Central University and knows all the best restaurants in town. The others who provided invaluable assistance are too many to name, but include Zeng Yongyi, Lin Heyi, Wang Anqi, Austin Mengchao Wang, and Li Yixiu, among others.

Scholars of modern Chinese theater in North America are growing in number, but still few, far between, and often only in the same room at conferences. My work has benefited immensely from early feedback at a number of these events, and I am grateful to have met so many kindred spirits in the process of sharing my work. To my nearer (and very dear) classmates and colleagues at in EALC and History at Harvard, I am so grateful to have you all as companions in our careers. My thanks especially to Einor Keinan-Segev for moral support and always being willing to read a draft. And to the Members and Friends of the Harvard Drama Colloquium, especially Elizabeth Phillips, Rebecca Kastleman, Samuel Adams, and Professors

Ju Yon Kim and Derek Miller: I cannot thank you enough for adopting me into a truly wonderful community. I am inspired and enriched by you all.

Finally, my family. Thank you to my mother and father, Anthony, Alyson, and Kelsey for helping me to stay silly and sane, for sending me emojis and brownies, and for more love and support than anyone deserves. And to Kyle, for everything. This one is for *us*.

Note on Romanization & Translation

I use the Pinyin system for Romanization of all Chinese terms, with the exception of proper names for which convention differs. These include the historical spellings of place names, names of leaders such as Chiang Kai-shek, and any artists or authors based in Taiwan. For Taiwanese names, I follow the Romanization that the author himself or herself uses whenever possible.

The translation of terms for Chinese performance styles and genres is inconsistent across English-language scholarship and often problematic. Therefore, for all types of performance, I note the most common translation at the first instance of a term, and use the original Chinese term in Pinyin for all subsequent references. For example, Beijing opera (*jingju* 京劇) will appear as *jingju* after first mention in the body of the dissertation. I hope that this slight decrease in ease of reading in exchange for greater accuracy will not trouble my readers too much.

Translations from Chinese to English are mine, unless otherwise noted.

Introduction

Five giant lotuses rise from the stage and unfurl, as if by magic, to reveal five Buddhas hidden within their petals. A crash of thunder sounds and a bright bolt of lightning illuminates the interior of the theater. A photorealistic image of Tiananmen 天安門, the Gate of Heavenly Peace, in perspective and almost life-sized, fills the space behind a revolutionary *tableau vivant*. Varying widely in style and historical context, these snapshots of scenes from Qing Dynasty (1644-1912) court pageants, early 20th-century spoken drama, and Maoist revolutionary dance-drama share in common their reliance on stage technologies, or *wutai jishu* 舞台技術. This broad category, synonymous with technical theater, can include everything from makeup and costumes to lights, sound, sets, special effects, mechanical props, and multimedia. Stage technologies can be credited with some of the best and the worst moments in live theater, propelling productions to spectacular aesthetic heights and smashing mechanical failures alike. Yet, most of the time, the technologies of performance are seen and heard, but unnoticed.

To be sure, this is often intentional. In realist theater, for example, the success of the play depends upon a fourth wall dividing the action onstage from its audience and the illusion of life-like representation. Real drawing rooms hardly have pulleys or trapdoors. On the opposite end of the spectrum, as in the ostentatious pageants of the Qing court or miraculous liturgical dramas of medieval Europe, we find stages filled with reality-defying mechanical tricks and pyrotechnics. However, the attitude toward technology is similar in that the success of the special effect depends upon its seeming mystery, whether imperial or divine. No one wants to see the strings behind the angel's ascension (or that of the Buddha's lotus). One might even argue that the same holds true for the many forms of classical Chinese theater beyond court pageants. Typically

performed with fewer trappings of the stage, both refined literati theater and the many regional sung drama (*xiqu* 戲曲) forms instead privileged costumes, makeup, and the technical virtuosity of actors—hiding even the messiness of corporeal tools behind stunning displays of acrobatic and vocal technique.

Nonetheless, these unsightly mechanisms are such stuff as dreams are made on—or at least, this dissertation will argue, such is the case in modern Chinese theater. I begin here with the assertion that the technical details of the theater deserve scholarly attention, in general, and that developments in Chinese theater over the last century, in particular, have been shaped in large part by their technologies. Over the course of four chapters and a brief interlude, I will identify specific moments at which there have been important innovations in or engagements with stage technology in the Chinese theater and explore the effects of those moments on dramatic literature, performance practice, and artistic theory. The topics covered are: lighting in early spoken drama (1930s), architecture as political theater (1950s), the body as an anti-technology in little theater productions (1980s), and new media in avant-garde performance (2010s). Throughout, I look at both how theater technology is *acted out* onstage and how it *acts on* dramatic text and audiences alike—a constellation of effects, affect, and action that alternately has served revolutionary goals, implemented ideology, and elicited resistance. What I find is that technological innovations and applications are often as connected to issues of politics as they are to artistic practice and pure aesthetics. This leads me to the main argument of the project, which is, in brief, that these Chinese cases reveal to us connections between the uses of technology in theater and how theater can function *as* a technology in the service of artistic and political goals alike. This general technicity proves crucial to our understanding of modern Chinese theater and its role in politics, culture, and society.

Setting the Stage

If one were in the dubious business of divining a point of origin for theater technology in China, one might trace back to the story of Han Wudi 漢武帝 (156 BCE-87 BCE) often retold as the putative origin of shadow puppetry:

“(After the death of Li Fu Jen) the emperor could not stop thinking of her. Shao Ong, a magician from Chhi, said that he could cause her spirit to appear. So after certain offerings of wine and meat had been set forth, and when certain lamps and candles had been disposed about a curtain, the emperor took his place behind another (diaphanous) curtain. After a time he saw indeed at a distance a beautiful girl sitting down and walking back and forth. But he could not approach her. Afterwards the emperor thought upon she all the more and, being sad, composed a poem somewhat to this effect: ‘Was it really she or was it not? I could not help rising from my seat. How was it that she walked so gracefully, yet seemed to come towards me so slowly?...’”¹

Here, the simple tools of oil lamps, candles, and a gauzy curtain enable a process of surrogation, to borrow loosely the term coined by Joseph Roach—a substituting of shadow for beloved that fails in its intent to soothe the grieving ruler.² Instead, however, he is prompted to a crisis of perception paralleling that found in another famed shadow-fable, Plato’s Allegory of the Cave. Like the story of Han Wudi, the plight of Plato’s cavedwellers simultaneously offers the imagination of an ancient form of puppet performance and illustrates how easy it is for dances of light and shadow to trick the eye.

Plato and his philosophy have been charged with contributing to a longstanding anti-theatrical bias in Western philosophy. In contrast, the story of Han Wudi is celebrated in histories of shadow theater and has even been offered as evidence that Chinese theater proper

¹ Original text found in the *Qian Hanshu* 《前漢書》 and Sima Qian’s *Shiji* 《史記》. Here quoted from the translation in Joseph Needham, *Science and Civilisation in China*, vol. 4.1 (Cambridge, UK: University Press, 1954), 78.

² Roach illustrates his term by writing of the process of filling an institutional role when someone has died or retired, and links this more broadly to processes of cultural formation and performance. The term may be appropriate because of Roach’s attention to the uncanniness of surrogation, which “may provoke many unbideen emotions, ranging from mildly incontinent sentimentalism to raging paranoia,” and that the substitution often fails. Joseph Roach, *Cities of the Dead: Circum-Atlantic Performance* (New York: Columbia University Press, 1996), 2.

developed out of an older tradition of puppetry.³ The latter thesis is somewhat idiosyncratic but interesting in its implication that Chinese theater has a close historic relationship with more mechanic arts—the craftsmanship of assembling puppets, design of the mechanisms for their movement. And indeed, the sparse records of court performances and festivals of the Song Dynasty (960-1279) and earlier include tantalizing lists of entertainments, many of which could very well have included technical tricks.⁴ After all, the use of a mechanical crane as *deus ex machina* dates to the ancient Greek theater, and there is no reason to think that as technologically advanced a civilization as the Chinese would have paused its development of stage technology at simple shadow puppets.

However, there is scant evidence for precisely *how* any such early stage technologies may have developed, and it is beyond the present scope of this study to examine the question in further detail. By the Ming dynasty (1368-1644), the evidence is somewhat better, and several previous studies have addressed questions of stages and staging in late imperial theater and performance. Scripts for literati and palace performances from the Qing dynasty suggest elaborate costuming and use of props, and the spectacular pageants held during the reign of the Qianlong emperor are well documented by preserved play texts, descriptions penned by visitors to the imperial court, and paintings. As scholars such as Wilt Idema, Andrea Goldman, and Xiaoqing Ye have noted, the context of court performance enabled the pursuit of theatrical novelty, encouraged the use of technological marvels to display the magnificence of the empire,

³ Sun Kaidi 孫楷第, *Kuilei xi kaoyuan* 《傀儡戲攷原》, Zhongguo xi qu li lun cong shu (Shanghai: Shang za chubanshe, 1952).

⁴ For an overview of early developments in the Chinese theater and translation of several important texts that provide descriptions of court entertainments and commercial theater from the Song, Jin, and Yuan, see W. L. Idema and Stephen H. West, *Chinese Theater, 1100-1450: A Source Book* (Wiesbaden: Steiner, 1982).

and established the theater's role as a potent political tool.⁵ For instance, the three-tiered stages constructed in palaces during the late 18th-early 19th centuries were outfitted with trap doors and pulley systems, by which actors could be lowered from above or raised up from below, and pumping devices were installed for special effects, like a giant sea turtle spewing water.⁶ Goldman, in her study of urban performance of this period, draws explicit connections not only between spectacle and power, but also between the technical *control* required of such productions and state ideological control.⁷ For her, this emphasis on control is significant in its contrast with the many entertainments flourishing outside the court, where the lack of control fostered more anarchic creativity throughout the urban milieu. For my study, its importance lies in the specific function of theater *technology* as a medium for conveying state *ideology*.

By the mid-19th century, the empire that represented itself through displays of grandiose technologies in palace theaters would, ironically, prove catastrophically deficient in technology on the global stage. In short, the defeat of the Qing military in the Opium Wars (1839-1842 and 1856-1860) brought into sudden relief China's lack of the industrial and military technologies that developed in the Industrial Revolution. Here, it is not my intention to reduce the conflicts of

⁵ In recent years, there have been a number of studies on Chinese court drama, especially of the Qing dynasty, in both Chinese and English. In English, see for example: W. L. Idema, *The Dramatic Oeuvre of Chu Yu-Tun (1379-1439)* (Leiden: Brill, 1985), 109; Wilt L. Idema, "Performances on a Three-tiered Stage: Court Theatre During the Qianlong Era," in *Ad Seres et Tungusos: Festschrift für Martin Gimm zu seinem 65. Geburtstag am 25. Mai 1995*, ed. Martin Gimm et al., (Wiesbaden: Harrassowitz, 2000), 201-19; Andrea S. Goldman, *Opera and the City: The Politics of Culture in Beijing, 1770-1900* (Stanford, CA: Stanford University Press, 2012), 108-109; Xiaoqing Ye, *Ascendant Peace in the Four Seas: Drama and the Qing Imperial Court* (Hong Kong: Chinese University Press, 2012).

⁶ Idema, "Performances on a Three-tiered Stage: Court Theatre During the Qianlong Era."

⁷ Goldman, *Opera and the City*, 109. In contrast, the court did not look so favorably on popular entertainments and public theaters, wherein all manner of seditious sentiments and immoral behaviors fomented. In addition to Andrea Goldman's book, for more nuanced discussions of *jingju* and other popular forms in the 19th century, see: Colin Mackerras, *The Rise of the Peking Opera, 1770-1870: Social Aspects of the Theatre in Manchu China*, (Oxford, UK: Clarendon Press, 1972); Joshua Goldstein, *Drama Kings: Players and Publics in the Re-Creation of Peking Opera, 1870-1937* (Berkeley: University of California Press, 2007), http://nrs.harvard.edu/urn-3:hul.ebookbatch.PMUSE_batch:PMUSE193420150515.

the Opium Wars to a narrative of technologically backwards China versus an advanced West; this would be an affront to the complexities of the history, not to mention the many excellent historical studies that cover this period. However, there is no doubt that one effect of the conflicts of the mid-19th century was to propel a shift in sentiment wherein the acquisition of “modernized,” “Western” science, technology, and industry became a priority of reformers and, at times, the state.⁸ Modern technology, broadly writ, figured as both a marker of national shame, in its lack, and a potential agent of change.

The technological crisis of the late Qing also contributed to the birth of modern Chinese theater, both materially and conceptually. On a practical level, the influx of foreigners and foreign goods in the wake of the Unequal Treaties brought new technologies like electric lighting, sound recording devices, and magic lantern slides, which transformed the landscape of urban entertainments. Teahouses, venues that had become centers of urban life and entertainment over the course of the 19th century, began to feature “foreign shadowplay” (*xiyang yingxi* 西洋影戲) in variety show programs alongside live *xiqu*, acrobatics, and magic tricks. At times, the live performance and performance of new, markedly foreign technologies were even more closely integrated.⁹ Film’s early moniker, “foreign shadowplay,” has led scholars like Zhang Zhen to acknowledge “its umbilical tie to the puppet show and other old and new theatrical arts—in

⁸ In the following, I will drop the scare quotes from these terms, but in using them here, I would like to acknowledge that these terms are constructs and often complicit in maintaining problematic binaries between old and new, East and West. Throughout this study, I try to be faithful to the use of these terms in particular contexts; for instance, when I discuss modern stage lighting of the 1920s-1930s in Chapter 1, the instruments that I include within this category were themselves identified as “tools of the modern stage” (*xiandai wutai gongju* 現代舞台工具). See for example the illustrations of lighting equipment in “*Xiandai wutai gongju zhi yiban* 現代舞台工具之一斑,” *Juxue yuekan* 《劇學月刊》 2, no. 7–8 (August 1933).

⁹ In a recent conference presentation, Peng Xu described gramophone recordings played within Cantonese opera performances in Shanghai during the 1890s. Peng Xu, “Listening to Theater: The Arrival of the Gramophone and Soundscapes of Theater in China, 1890s-1920s” (CHINOPERL Annual Conference, Seattle, March 31, 2016).

particular, the modern stage drama from the West via Japan.”¹⁰ In this lineage, film is often linked back to the same story of Han Wudi and his shadowy concubine that I am arguing constitutes an (admittedly apocryphal) moment of originary technicity in the theater.¹¹ As Zhang also notes, film and theater would maintain a close relationship through the first decades of the 20th century, even as film semantically shed its connections to both the West (*xiyang* 西洋) and the theater (*yingxi* 影戲) to become “electric shadow” (*dianying* 電影).

Electrification brought changes to the theater proper, as well. Electric lights were first installed in certain Shanghai “play gardens,” or teahouse theaters (*xiyuan* 戲園) as early as 1886—only five years after the world’s first installation of incandescent light bulbs in a theater, in the Savoy Theater in London.¹² They were also a common and much appreciated feature of what Joshua Goldstein calls the “Republican playhouse”—a new architectural style modeled on foreign-built proscenium theaters in Shanghai that became popular in the first two decades of the 20th century. With their well-equipped stages and orderly rows of seating, Goldstein argues that:

Like public parks, squares, sports arenas, and other spaces associated with modern nation-building, the new theaters were as much spaces of liberation from old hierarchies as they were technologies to discipline and reorder society to serve new aims. But what

¹⁰ Zhang Zhen, “Teahouse, Shadowplay, Bricolage : Laborer’s Love and the Question of Early Chinese Cinema,” in *Cinema and Urban Culture in Shanghai, 1922-1943*, ed. Yingjin Zhang (Stanford, CA: Stanford University Press, 1999), 34.

¹¹ I agree wholeheartedly with Zhang Zhen’s statement on the matter of shadowplay as a point of origin: “While one should be mindful of the risk involved in any such attempt to fix an originary moment of a cultural category, the overlap of the puppet shadow play and ‘foreign shadowplay’ in the late Qing and the early Republican period nevertheless deserves critical attention, if one considers cinema as at once an international and contested modern cultural practice.” *Ibid.*, 33.

¹² As Joshua Goldstein discusses in *Opera Kings*, there were several types of venues for performance in Beijing and Shanghai. *Xiyuan* were large commercial venues that served tea and snacks during performances and, according to Goldstein, were referred to as “teahouses” (*chayuan* 茶園) to help evade government restrictions. Liao Ben cites a *Shenbao* 《申報》 article from 1886 in arguing that electric lights were used in *xiyuan* in Shanghai well before the 20th century. Goldstein, *Drama Kings*, 60–61; Liao Ben 廖奔, *Zhongguo gu dai ju chang shi* 《中國古代劇場史》, *Zhongguo chuan tong wen hua yan jiu cong shu* (Zhengzhou: Zhongzhou guji chubanshe, 1997), 159–160; Oscar G. Brockett, *History of the Theatre*, 7th edition (Boston: Allyn and Bacon, 1995), 404.

makes the theater especially useful for investigating the deeper epistemological workings of such technologies is that it clearly illustrates the integral linkage between new practices of discipline and a new regime of representation. The cordoning off of representation from reality became the primary organizing and disciplining logic of theater reform, a logic enforced by changes in the relationship between audience and actors, the stage and the seating areas.¹³

In this, the theater would find itself once again implicated as a technology of ideology, although the regime and the mechanisms had changed. At the same time, these new theaters and their modern stage equipment also offered opportunities for experimentation with spectacular lighting and special effects, as in the “five colored electric lights” (*wuse dianguang* 五色電光) used for Mei Lanfang’s famous performance of *Tiannü sanhua* 《天女散花》 (A Fairy Maiden Scatters Flowers) at the Dangui No. 1 Stage (Dangui Diyitai 丹桂第一台) and the scenographic experimentations of “civilized drama” (*wenmingxi* 文明戲), a genre that developed in the first decade of the 20th century.¹⁴

The first calls to actively reinvent Chinese theater in terms of its content, form, and social function—in effect, to engineer a break with the past that would make it modern—likewise can be linked to the technological crisis of the late Qing. In the latter decades of the 19th century, Chinese reformers focused their energies on technological and institutional modernization in the Self-Strengthening Movement (1861-1895). However, with the repeated defeat by a foreign power in the first Sino-Japanese War (1894-1895) and failure of the Hundred

¹³ Goldstein, *Drama Kings*, 56.

¹⁴ Catherine Vance Yeh discusses the importance of “five-colored tracking lights” to the development of Mei Lanfang’s practice and aesthetics in her work-in-progress on the interaction of *jingju* and modern dance. In relation to *wenmingxi*, Siyuan Liu notes the importance of lighting and “realistic” sets used at theaters like the Lyceum, as well as the direct involvement of Japanese designers, technicians, and carpenters in productions in Shanghai. Catherine Vance Yeh, “Mei Lanfang’s ‘The Goddess Spreads Flowers’ and the Inherent Ambiguity of Modernism” (Association for Asian Studies Annual Conference, Seattle, WA, April 2, 2016); “Recasting Peking Opera: Modern Dance, Invented Tradition and the Visual Turn” (CHINOPERL Annual Conference, Seattle, WA, March 31, 2016); Siyuan Liu, *Performing Hybridity in Colonial-Modern China* (New York: Palgrave Macmillan, 2013), 60–61.

Days Reform, prominent intellectuals turned their attention to culture. Perhaps the most famous of these was Liang Qichao 梁啟超 (1873-1929), who famously called for the reform of fiction and drama as didactic tools in an influential essay published in 1902.¹⁵ In his erudite study of *wenmingxi*, Siyuan Liu argues for the importance of Japan's modernization—in particular, the role that the theater had played therein—as an inspiration for reformers like Liang Qichao. Together, the successful reform of kabuki and the rise of *shinpa*, which in turn were indebted to nationalist French theater as a model, provided Chinese reformers with powerful precedents for culture as an instrument of national rejuvenation.¹⁶ Equally important, as Liu points out, were both visions of theatrical performances and the physical theaters themselves. Liang Qichao's calls for reform would be echoed widely in the following decades as May Fourth intellectuals and others took up the call for literature and the arts to simultaneously reflect a distinctly Chinese culture and actively participate in the formation of modern subjects for a modern nation.

Thus burdened and overdetermined, theater and technology meet on the Chinese stage in the early decades of the 20th century. Modern technologies imported from the West brought material changes to stages and opportunities for vernacularization. Theater architectures and the spatial relations therein changed with the introduction of the proscenium theater. Theater, already with an historical tie to state ideology, was further tasked with bringing about sweeping social, cultural, and political changes. And in the interstice between the material and the ideological, we find the theater artist. Neither material technology nor ideology fully determines these human agents, yet their work in the art of the theater is deeply intertwined with both. It is in this context

¹⁵ Liang Qichao, "On the Relationship between Fiction and the Government of the People," in *Modern Chinese Literary Thought: Writings on Literature, 1893-1945*, ed. and trans. Kirk Denton (Stanford, CA: Stanford University Press, 1996), 76–81.

¹⁶ Liu, *Performing Hybridity in Colonial-Modern China*, 14–17.

that theater artists begin using the term *wutai jishu* in the discourse surrounding the Chinese theater. The term appears, rather suddenly, in articles and advertisements newspapers and periodicals in the late 1920s, used to refer to both elements of technical theater—sets and lights, especially—and performance technique.¹⁷

It is at this moment of naming that this dissertation begins. Throughout, I am interested in three sets of questions related to stage technology in modern and contemporary China. First, on a material level, how have technological shifts influenced the development of modern Chinese theater? How do lights, sound, sets, special effects, and new media shape performance aesthetics and how are they reflects in dramatic literature? Second, on the level of craft, what changes in performance practice and audience reception have accompanied these shifts? How does technology affect visions of the relationship between artist, artwork, and audience? And third, when and how does the theater itself become a tool in the service of social, political, or ideological agendas? What, if any, relationship is there between technologies *of* the theater and the instrumentalization of the theater *as* a technology?

Terminology

Having sketched the historical roots of theater technology in China and rooted my study in a particular discursive act, a few words on the key terms in question may be in order.

Technology is, as historian of science Leo Marx has remarked, a hazardous concept. Tracing the genealogy of the term and the rise of its use in American parlance, Marx argues that the term has

¹⁷ The earliest mentions of the term that appear in searches of the *Shenbao* 《申報》 ERUDITION database, which covers 1872-1949, date to 1928; in the Shanghai Library Late Qing/Chinese Periodical Full-text databases, which cover 1833-1911 and 1911-1949, the earliest articles are a series by Zhao Taimou 趙太侖 published in the drama section of the *Chenbao fukan* 《晨報副刊》 in 1926. In the former case, the term is used in an advertisement for a dance workshop and seems to refer to performance technique. In the latter, it is paired with stage scenery/sets (*bujing* 佈景). The term *wutai shu* 舞台術 is rarely used, but does appear in a few *Shenbao* articles from 1924.

strayed far in its etymology; beginning as a name for a field of study, technology in the first half of the 20th century came to encompass “society’s entire stock of technical knowledge and equipment.”¹⁸ Ambiguity has been amplified by reification, and today we find the term’s usage expanded until technology itself becomes “endowed with a thing-like autonomy and a seemingly magical power of historical agency.”¹⁹ Marx targets historians of science and technology with his words of warning, but one need look no farther than pop cultural techno-optimism—with its faith that new technologies guarantee an ever better, brighter future despite equally possible dystopias of surveillance and mass mediated war—to understand his point.

My engagement with technology, however, is neither technophilic nor technophobic. Instead, I argue for the continued utility of the term in reference to the three specific phenomena highlighted in the above historical overview: (1) material and mechanical developments in theater equipment (*technologies*), (2) the craft and skills of human agents (*technique*), especially in the performing arts, and (3) the utilitarian appropriation of arts and culture in the service of various, often political agendas (*technologization*). In this tripartite definition, I am perhaps better served by the term “*technics*,” as used in the work of Lewis Mumford and Bernard Stiegler. Mumford’s seminal *Technics and Civilization* (1934), which has enjoyed a renewal of scholarly interest in relation to media studies and philosophy (due perhaps in part to a re-issue of the volume by the University of Chicago Press in 2010), is instructive in its focus on agency, ethics, and cultural values in relation to the development of tools and machines.²⁰ His use of the term “*technics*” encompasses both *technologies* and *technique*—an implicit return to the Greek

¹⁸ Marx also draws a strong contrast between the “mechanic arts” and technology. Leo Marx, “Technology: The Emergence of a Hazardous Concept,” *Technology and Culture* 51, no. 3 (2010): 574, doi:10.1353/tech.2010.0009.

¹⁹ *Ibid.*, 576.

²⁰ Lewis Mumford, *Technics and Civilization*, University of Chicago Press ed. (Chicago: University of Chicago Press, 2010).

root of *techne* and its association with skill, craft, and art that anticipates Martin Heidegger's famous discussion in "On the Question Concerning Technology" (1954). More recently, French philosopher Bernard Stiegler's *Technics and Time*, in dialogue with Heidegger, Husserl, and Derrida, has traced *techne*/technics even further back in human history and argued that technics and the human share a point of origin.²¹ Where Stiegler demonstrates that technics and the human are mutually constitutive, I make a much narrower argument for a similar relationship between technics and one sphere of human cultural production: the theater.

The more capacious understanding enabled by "technics" also better aligns with the constellation of Chinese words that are related to technology, technique, skills, and craft. One recent comparative study of the concept of technology defines the component terms of its most common analog, *jishu* 技術, as follows:

In ancient Chinese, *ji* and *shu* were always used separately. According to *Shuowen jiezi*, *ji* means "ingeniousness and skillfulness of craftsman", with an extended meaning of "(exclusive) talent and the ability of craftsmen in general", although it sometimes refers to "certain special arts" such as singing and dancing. *Ji* can be acquired only by intuition and understanding and be perfected through practice. The original meaning of *shu* is "the ways or roads in the town", with an extended meaning of "skill, method, procedure". *Shu* refers not only to the skill, method and process in physical making and using, but also to mental action, political trickery, martial arts, art, arithmetic calculating, necromancy, Daoist magic, and more. In this sense, Chinese knowledge is based on *shu*, which means that it pays more attention to the configuration of methods and procedures in order to memorize and be able to use them flexibly in practice.²²

While the author's last statement seems too sweeping a generalization, the list of related terms is instructive in its range. *Shu* also forms a point of semantic connection between technology and

²¹ Bernard Stiegler, *Technics and Time*, 3 vols. (Stanford, CA: Stanford University Press, 1998).

²² Nan Wang, "Philosophical Perspectives on Technology in Chinese Society," *Technology in Society* 35, no. 3 (August 2013): 166, doi:10.1016/j.techsoc.2013.05.001; Liu Juncan 劉君燦, "Zhongguo chuantong jishu sixiang yu xifang sixiang de duizhao 中國傳統技術思想與西方思想的對照 (A Comparison between Ancient Chinese Technological Thoughts and Western Ones)," *Kexue yuekan* 《科學月刊》 320 (August 1996): 686–90.

art as the shared second term in *jishu* 技術 and *yishu* 藝術 (art). In English, a similar difference is embedded in the definition of the English term *technology* via one of its Greek roots, *techne*, which like *shu* is related to skill, craft, and art.²³ In contrast, technology in a modern sense takes as one of its definitions, “The application of such knowledge for practical purposes, esp. in industry, manufacturing, etc.; the sphere of activity concerned with this; the mechanical arts and applied sciences collectively.”²⁴ This split is perhaps most famously problematic for Heidegger in “The Question Concerning Technology” (1954). In this piece, Heidegger counters a problematic “instrumental and anthropological” definition, i.e. the more common contemporary understanding, with an understanding of technology as *techne* rooted in *poesis*, or bringing-forth.²⁵ For Heidegger’s philosophy, the a central problem with modern technology is that it privileges the former at the expense of the latter; in the case of theater, which is not necessarily concerned with the same questions of Being as is Heidegger, the *overlap* between the two concepts of technology and *techne* that is most intriguing. The blurring of the distinction between the *instrumental* and the *artistic* opens up a space for the consideration of the relationship between the two in relation to the “work” of art in the modern world.

Chinese film and media scholar Bao Weihong has recently made a similar argument for *shu*, translated as “technics,” as an important heuristic in the study of early 20th century art and culture in China. Using dramatist Hong Shen 洪深 (1894-1955) as a case in point, Bao references Mumford and Stiegler, but draws her understanding of technics primarily from essays

²³ Oxford English Dictionnaire Online, s.v. "techne, n.", accessed May 13, 2015, <http://www.oed.com.ezp-prod1.hul.harvard.edu/view/Entry/273538?redirectedFrom=techne>.

²⁴ Oxford English Dictionnaire Online, s.v. "technology, n.", accessd May 13, 2015, <http://www.oed.com.ezp-prod1.hul.harvard.edu/view/Entry/198469?redirectedFrom=technology>.

²⁵ Martin Heidegger, “The Question Concerning Technology,” *Basic Writings*, trans. David Krell, (New York: Harper Perennial, 2008), 312, 319.

written in the late 1920s on “the technics of acting” (*biaoyan shu* 表演術).²⁶ In her earlier work on Chinese cinema and affect, Bao argued that *shu* can be linked to a technologized concept of the actor’s body that works in concert with other technologies, like film, to affectively mobilize audiences; here, she draws a connection between *shu* and what she terms the “art of control,” wherein theater aesthetics, behavioral psychology, and engineering design combine in the service of social transformation.²⁷ It is perhaps no coincidence that Hong Shen published his theses on *biaoyan shu* at almost exactly the same time the term *wutai jishu* began to appear in the popular press, noted above. Indeed, in the decades following, we find theater artists widely using *shu* and *jishu* to refer to all elements of stagecraft with terms such as “actors’ technique” (*yanyuan jishu* 演員技術), “directors’ technique” *daoyan jishu* 導演技術, and “performance technique” (*biaoyan jishu* 表演技術). All of these might be rendered as “technics” as a means of highlighting the overlap among technologies, techniques, and systems of control.²⁸ The term *wutai jishu* sometimes even encompasses the acting and directing-related terms, further confirming Bao Weihong’s arguments about the correspondence between actor and stage machine. Thus, in what

²⁶ As Bao notes, Hong Shen published this series of five essays in *Dianying yuebao* 《電影月報》, a major film journal at the time, in 1928. In the 1930s, the essays were also included in Hong Shen’s collections *Dianying xiju biaoyan shu* 《電影戲劇表演術》 (Technics of Acting for Film and Drama, 1934) and *Xiju de fangfa he biaoyan* 《戲劇的方法和表演》 (Dramatic Methods and Performance, 1939). Weihong Bao, “The Art of Control: Hong Shen, Behavioral Psychology, and the Technics of Social Effects,” *Modern Chinese Literature and Culture* 27, no. 2 (Fall 2015): 254.

²⁷ In her earlier work, Bao also mentions the articles by Hong Shen, but translates *shu* as “technology.” See Weihong Bao, *Fiery Cinema: The Emergence of an Affective Medium in China, 1915-1945* (Minneapolis, MN: University of Minnesota Press, 2015), 54–57.

²⁸ See for example, Yi Yun 逸雲, “Yanyuan de jishu” [演員的技術] (Actors’ Technique), *Zhengzhi qianxian* 《政治前線》 2.12 (1941): 15-17; Wang Ruilin 王瑞麟, “Daoyan jishu” [導演技術] (Directing Technique) *Xiju yu wenyi* 《戲劇與文藝》 1.7 (1929): 6-53; Si Nairuo 斯乃若, “Guanyu xiju de biaoyan jishu” [關於戲劇的表演技術] (Regarding Theater Performance Techniques) *Zhandi* 《戰地》 2.8 (1939): 9-11. In the article by Wang Ruilin, the usage may indeed be a loan, given that the author cites Halliam Bosworth *Technique in Dramatic Art* (Macmillan Company, 1926) as a reference following the article.

follows, I generally will refer to individual technologies, but nonetheless am always in dialogue with the larger systems of technics at work in modern Chinese art and culture.

Literature Review

In theater scholarship, technology remains, as it often does onstage, largely in our line of sight but out of mind. That is to say, studies of Chinese theater often acknowledge the importance of things we might categorize as stage technologies to mise-en-scene, stage aesthetics, and performance context, but rarely provide a nuanced analysis of how these elements work in concert. For examples of this, we might turn to the otherwise excellent work of theater scholars like Xiaomei Chen and Claire Conceison, who both focus on Chinese *huaju* from the latter decades of the 20th century.²⁹ With backgrounds in theater studies, both offer throughout their various articles and monographs comprehensive analyses of important productions that combine performance analysis with close readings of literary text and thick descriptions of historical, social, and political context. Innovations in dramaturgy, directorial aesthetic, and design are all taken into consideration; however, whereas they frequently pause to unpack the subtleties of a passage of the script or a directorial decision, lighting and sound cues largely remain couched in generalities.

Highly technical discussions are more frequently found in publications on the classical theater and contemporary *xiqu*, which often focus on elements seen to bespeak “Chineseness”, such as the makeup, costumes, props, and stage architecture. The complexity of performance

²⁹ Xiaomei Chen, *Occidentalism: A Theory of Counter-Discourse in Post-Mao China*, 2nd ed., rev. and expanded. (Lanham, MD: Rowman & Littlefield, 2002); Xiaomei Chen, *Acting the Right Part: Political Theater and Popular Drama in Contemporary China* (Honolulu: University of Hawai'i Press, 2002), http://nrs.harvard.edu/urn-3:hul.ebookbatch.PMUSE_batch:muse9780824861360; Claire Conceison, *Significant Other: Staging the American in China* (Honolulu: University of Hawai'i Press, 2004), http://nrs.harvard.edu/urn-3:hul.ebookbatch.PMUSE_batch:muse9780824864316.

systems such as *jingju* 京劇 has prompted efforts to catalogue, in great detail, their conventions of costume, makeup, role type, music, and gesture. Early 20th century English-language guides, now dated in their blatant exoticism, offer explanatory texts as keys to unlocking the “secrets” of such forms.³⁰ For more objective examples, one might look to volumes illustrating makeup designs (*lianpu* 臉譜) for the “painted face” (*hualian* 花臉) characters, or Elizabeth Wichmann-Walczak’s encyclopedic description of musical composition, orchestral arrangement, and voice in *Listening to Theatre: The Aural Dimension of Beijing Theatre*.³¹ The latter raises the intriguing question of whether or not music, as traditionally incorporated in *xiqu* performance, might also constitute a stage technology.

There also exists a growing body of literature in Chinese on topics such as architecture and stage design, but, as with the above, many of these are historical and encyclopedic. In terms of theater architecture, many previous studies have primarily concerned themselves with material evidence for historical conditions of performance. For example, surveys of extant ancient stages, such as the *Zhongguo juchang shi* 《中國劇場史》 (A History of the Chinese Stage) by Zhou Yibai 周貽白 and, more recent work by Liao Ben 廖奔 provide archeological and pictorial data on pre-modern theater architectures.³² In addition, the recent burgeoning of theater construction has led to the publication of equally technical volumes on new, state-of-the art theaters. Of these, *Zhongguo xiandai juchang de yanjin – cong da wutai dao da juyuan* 《中國現代劇場的演進：

³⁰ See for example Cecilia S. L. Zung, *Secrets of the Chinese Drama; a Complete Explanatory Guide to Actions and Symbols as Seen in the Performance of Chinese Dramas*, (Shanghai, Kelly and Walsh, 1937).

³¹ Elizabeth Wichmann, *Listening to Theatre: The Aural Dimension of Beijing Opera* (Honolulu: University of Hawaii Press, 1991).

³² Zhou Yibai 周貽白, *Zhongguo ju chang shi* 《中國劇場史》, 再版., Zai ban., Xi ju xiao cong shu (長沙: 商務印書館, 民國 29 1940, Changsha, 29); Liao Ben 廖奔, *Zhongguo gu dai ju chang shi* 《中國古代劇場史》.

從大舞台到大劇院》(On the Evolution of Modern Theaters in China – a History from Grand Stage to Grand Theater) by Qinghua University and Harvard Graduate School of Design graduate Lu Xiangdong offers a detailed analysis of theater designs, facilities, and equipment, including photographs and architectural cross-sections, from the late 19th century to the present.³³ Aesthetic analysis is more prominent in the realm of scenic design. Since the mid-20th century, work by scenographers based at the major theater academies in China, such as Gong Hede 龔和德, Han Shangyi 韓尚義, Hu Miaoshen 胡妙勝, and others, has attempted to establish a comprehensive historical narrative and theoretical framework for scenic design.

In fact, communities of stage, lighting, and multimedia designers and technicians in mainland China, Hong Kong, and Taiwan are thriving, and produce a great deal of practical and academic work. They are well connected internationally with groups such as the International Organization of Scenographers, Theater Architects, and Technicians (OISAT) and participate in exhibitions such as the Prague Quadrennial of Performance Design and Space. Furthermore, many preeminent designers also teach at institutes like the Central Academy of Drama (Zhongyang xiju xueyuan 中央戲劇學院), National Academy of Chinese Theater Arts (Zhongguo xiqu xueyuan 中國戲曲學院), and the Shanghai Theater Academy, STA (Shanghai xiju xueyuan 上海戲劇學院) in the People's Republic of China (PRC) and the Taipei National University of the Arts (Guoli Taibei yishu daxue 國立台北藝術大學) in Taiwan, and therefore publish frequently in academic journals and through academic presses. Topics of publication encompass the authors' own work as well as more historical and theoretical reflections, leading

³³ Lu Xiangdong 卢向东, *Zhongguo xiandai juchang de yanjin - cong da wutai dao da juyuan* 《中國現代劇場的演進——從大舞台到大劇院》(On the Evolution of Modern Theaters in China – a History from Grand Stage to Grand Theater) (Beijing: Zhongguo jianzhu gongye chubanshe, 2009).

to a valuable body of primary and secondary materials. One of the goals of this study is to bring their work into conversation with English-language scholarship on Chinese theater, which to date has given neither theater technology nor the related Chinese-language scholarship due attention.

It should also be noted that, even in Chinese-language scholarship, there is often a division between practice-based scholarship, such as the examples listed above, and literary studies. This bifurcation parallels the historical separation of the study of dramatic literature, housed in language and literature departments, and theater practice, in theater and performance studies departments or conservatories, found in the United States. The state of the field perhaps can be credited for what often feels like an anti-theatrical bias in scholarly production. Even with the contributions of academic designers, the majority of the scholarly work produced on Chinese theater is still literary and historical; literary analyses of classic Ming dynasty *chuanqi* 傳奇 such as *Mudanting* 《牡丹亭》 (The Peony Pavilion) still far outnumber studies of late imperial staging practices, and modern playwright Cao Yu 曹禺 (1910-1996) is most celebrated for his contributions to the literary canon, despite the fact that he led one of the most important theater companies in the PRC for decades. Recent trends in interdisciplinary scholarship have helped to soften this barrier, both in the study of Chinese drama and Western. This study likewise takes an interdisciplinary approach and contributes to these efforts by showing that even the most technical of details can and do influence literary composition.

In this approach, I am most indebted to several recent publications in the field of Chinese theater studies. First, the two monographs by Joshua Goldstein and Siyuan Liu cited in the historical overview, are invaluable both as sources of historical information and for the theoretical frameworks employed therein. In particular, Goldstein's approach to *jingju* as "an object of a certain kind of knowledge production, enmeshed in the context of colonial modernity"

and his consistent attention to the various ways in which institutions, spaces, and art forms can and did function as technologies of modernizing project has informed much of my analysis.³⁴ Similarly attuned to colonial modernity, Liu's study of *wenmingxi* as a thoroughly hybrid form provides a model for the integrated discussion of text, performance, and context, with close attention to the technical details of theatrical productions even when they are not the focus *per se*. Perhaps the only limitation of these two studies is their temporal coverage; both cover only a few decades around the turn of the 20th century. On the one hand, this focus enables them both to make subtle and convincing arguments about a crucial moment in Chinese theater history, but on the other, it leaves open the question of how this moment influences later developments. Temporally, my project picks up where they leave off and tests similar methodologies against a longer duration trajectory of continuity and change. Along the way, I am aided also by the work of PRC-based scholar Chen Jun 陳軍, whose study of the Beijing People's Art Theater, or BPAT, (Beijing renmin yishu juyuan 北京人民藝術劇院) is one of the few in Chinese to bring together literary analysis with a nuanced reading the production process, and Rossella Ferrari's work on contemporary theater in the PRC and Hong Kong.³⁵ Ferrari's work on intermediality in Chinese theater and the significance of transmedia aesthetics in the context of transnational artistic production, in particular, directed me to relevant theoretical texts and provided a crucial starting point for my discussion of new media technologies onstage in Chinese theater of the last decade.

³⁴ Goldstein, *Drama Kings*, 5.

³⁵ Chen Jun 陳軍, *Xiju wenxue yu juyuan juchang : yi "Guo, Lao, Cao" yu Beijing renyi weili* 《戲劇文學與劇院劇場：一郭，老，曹與北京人藝為例》 (Drama literature and theatre : Guo Moruo, Lao She, Cao Yu and Beijing people's theatre as an example) (Beijing: Shehui kexue wenxian chubanshe, 2011); Rosella Ferrari, *Pop Goes the Avant-Garde: Experimental Theatre in Contemporary China*, Enactments (London: Seagull, 2012); Rossella Ferrari, "Architecture And/in Theatre from the Bauhaus to Hong Kong: Mathias Woo's Looking for Mies," *New Theatre Quarterly* 28, no. 1 (2012): 3–19; Rossella Ferrari, "The Stage as a Drawing Board: Zuni Icosahedron's Architecture Is Art Festival," *TDR: The Drama Review* 55, no. 1 (2011): 137–49.

For its methodological and theoretical inspiration, my dissertation draws on two main bodies of scholarship beyond the works mentioned above: recent interdisciplinary studies on media, technology, and labor in Western theater and scholarship on Chinese film, visual culture, and sound studies. Since the 1970s, the use of televisual and now digital technologies in live performance has given rise to scholarly attempts to analyze new aesthetic forms and theoretical debates on the ontological status of theater vis-à-vis these various new media. In terms of the former, I draw on the work of Steve Dixon, Barry Smith, and Chris Salter, which offer models for tracing the historical transformation of technology in performance in a way that highlights both deep continuities and significant innovations.³⁶ For more theoretical considerations, I follow the ongoing debates on “liveness” in performance incited by Philip Auslander and Peggy Phelan in the 1990s to current conversations on the theatrical medium and intermediality, as in the studies of Samuel Weber, Chiel Kattenbelt, Sarah Bay-Cheng, and others.³⁷ Many of these studies, despite their provocative engagements with the aesthetic, ontological, and practical issues surrounding new media in theater, nonetheless remain quite traditional in their focus on the theatrical performance as a total work of art, with actors and directors as its primary creators. However, in parallel to these studies of media in performance, other strains of scholarship have developed that give more attention to issues of design, as well as the roles of designers and technicians. Here, I am indebted to the body of work on theater architecture and its semiotics,

³⁶ Steve Dixon, *Digital Performance: A History of New Media in Theater, Dance, Performance Art, and Installation*, Leonardo Books (Cambridge, Mass: MIT Press, 2007); Chris Salter, *Entangled: Technology and the Transformation of Performance* (Cambridge, Mass: MIT Press, 2010).

³⁷ For a full list of sources on intermediality and theater, see the discussion in Chapter 4. Peggy Phelan, *Unmarked: The Politics of Performance* (New York: Routledge, 1993); Philip Auslander, *Liveness: Performance in a Mediatized Culture*, 2nd ed. (New York: Routledge, 2008); Samuel Weber, *Theatricality as Medium*, 1st ed. (New York: Fordham University Press, 2004); Freda Chapple, Chiel Kattenbelt, and International Federation for Theatre Research. Theatre and Intermediality Working Group, *Intermediality in Theatre and Performance*, Themes in Theatre ; 2 (New York: Rodopi, 2006); Sarah Bay-Cheng, *Mapping Intermediality in Performance*, MediaMatters (Amsterdam: Amsterdam University Press, 2010).

inaugurated by Marvin Carlson, and on scenography, such as the work of Arnold Aronson.³⁸ Finally, as evidenced by the theme of the 2016 conference for the Association of Theater in Higher Education—“Bodies at Work: Performance, Labor, and ATHE”—the issue of theatrical labor very recently has become a key concern of theater and performance studies. Recent work in this vein that has turned attention to backstage labor, such as Christin Essin’s recent monograph on American stage designers and an edited volume by Elizabeth Osborn and Christine Woodworth, has been equally helping in framing my multidimensional study of theater technology in the Chinese context.³⁹

The value of paying attention to technical details is also well demonstrated by recent scholarship on Chinese film, visual culture, sound studies, and media studies. In particular, the work of scholars like Zhang Zhen, Andrew Jones, Laikwan Pang, and Weihong Bao calls attention to the intricate relationships among the technologies of cultural production, audience reception and engagement, and broader socio-political shifts.⁴⁰ Each of their studies is rooted in the close analysis—close reading, if you will—of the unique ways in which individual technologies like photographic and film cameras or gramophones connect to the social and economic apparatuses of popular culture, mass marketing, and commerce. These technologies

³⁸ Marvin A. Carlson, *Places of Performance: The Semiotics of Theatre Architecture* (Ithaca, NY: Cornell University Press, 1989); Erika Fischer-Lichte and Benjamin Wihstutz, *Performance and the Politics of Space: Theatre and Topology*, Routledge Advances in Theatre and Performance Studies ; 24 (New York: Routledge, 2013); Arnold Aronson, *Looking into the Abyss: Essays on Scenography*, Theater--Theory/text/performance (Ann Arbor: University of Michigan Press, 2005).

³⁹ Christin Essin, *Stage Designers in Early Twentieth-Century America: Artists, Activists, Cultural Critics* (New York: Palgrave MacMillan, 2012); Elizabeth A. Osborne and Christine Woodworth, *Working in the Wings: New Perspectives on Theatre History and Labor* (Carbondale: Southern Illinois University Press, 2015, 2015).

⁴⁰ Andrew Jones, *Yellow Music: Media Culture and Modernity in the Chinese Jazz Age* (Durham, NC: Duke University Press, 2001); Zhang Zhen, *An Amorous History of the Silver Screen: Shanghai Cinema, 1896-1937*, Cinema and Modernity (Chicago, Ill: University of Chicago Press, 2005); Laikwan Pang, *The Distorting Mirror: Visual Modernity in China* (Honolulu: University of Hawai’i Press, 2007), http://nrs.harvard.edu/urn-3:hul.ebookbatch.PMUSE_batch:muse9780824864675; Bao, *Fiery Cinema*.

then, in turn, play their parts in the creation of new scopic regimes or soundscapes and various subject formations—revolutionaries, citizens, consumers. It is the goal of this dissertation to demonstrate that what is true for mechanically reproducible technologies is no less significant to arts of a more ephemeral and immediate constitution.

Chapter Outline

Building on the groundwork laid by the scholarship discussed above, this project sets out to examine the material, practical, and conceptual relationships between stage technology and Chinese theater in the 20th-21st centuries. It proceeds chronologically and often, more often than I would like, hews closely to politically significant dates. However, it is driven not by the at-times inescapable grand narrative, but rather by the impulse to follow a paper trail of technical documents and drawings—archival traces that hint at an alternate blueprint for Chinese theater history. These sources have largely been erased from the historical record and literary analysis. Therefore, in addition to my historical and theoretical arguments about the importance of technology in the theater and the theater as a technology, I also advance a methodological argument related to the technicity of my primary source materials: theater blueprints, set designs, blocking diagrams and notation, schematic drawings of stage equipment, and their parsimonious accompanying text.⁴¹ As literature and theater scholars, we tend to approach such documents as

⁴¹ We might compare this approach to the study of *tu* 圖 (graphic images) outlined by Francesca Bray, who suggests that technical images be defined in contrast to the premodern visual categories of *hua* 畫 (picture or painting) and *xiang* 象 (image or icon); *tu* were unique in “denoting only those graphic images or layouts which encoded technical knowledge: *tu* were templates for action.” Francesca Bray, “The Powers of Tu,” in *Graphics and Text in the Production of Technical Knowledge in China: The Warp and the Weft*, ed. Francesca Bray, Vera Dorofeeva-Lichtmann, and Georges Métaillie, Sinica Leidensia, v. 79 (Boston: Brill, 2007), 2.

useful addenda to performance analysis, significant but secondary to scripts, recordings, and photographs.⁴²

However, I argue that we should take care not to fall prey to the technical fallacy behind this tendency, i.e. that these documents are transparent and therefore too easily understood to be of interest. Anyone who has ever assembled a piece of Ikea furniture can tell you that this is not the case. Simple line drawings do *not* necessarily point their reader to a clear interpretation. (Quite the contrary.) Rather, as I will demonstrate throughout this dissertation, such documents are both interpretive and interpretable. That is to say, they tell us something about how their author imagined the thing pictured, be it Ikea chair or lighting plot, *should* be made, but also vary in their relationship to the thing that could be or was made. These documents therefore ought to be read as literary texts, both as components of staged dramatic literature and in their own right.

Chapter 1, “Technical Difficulties: Politics, Practicalities & *Play* in 1930s Shanghai Theater” pairs analysis of detailed stage plans for a performance of Sergei Tretyakov’s *Riuchi, Kitai!* (Roar, China! or *Nuhou ba, Zhongguo!* 《怒吼吧，中國！》) with a large body of articles and treatises on theater lighting published in the 1930s. In it, I argue that Chinese theater artists used *Roar, China!* as a testing ground for theories of how stage and lighting design could be used to generate specific emotions in audience members and incite them to political action.

Chapter 2, “Socialist Utopian Special Effects: Monumental Theater Technology and National Imaginary in the Early PRC,” turns to the 1950s and uses architectural journal and blueprints to demonstrate the importance of physical performance space to nation building.

⁴² An important exception lies in recent work done in book history, for example Julie Stone Peters’ engagement with “engravings of theatre architecture, the stage designs, the images of actors in their roles, the posters and playbills, programmes and promptbooks, notation systems for acting, dance, and gesture, theatre calendars, biographies and autobiographies, playlists, scrapbooks, and souvenirs” in her study of the relationship between publishing and performance. Julie Stone Peters, *Theatre of the Book 1480–1880* (Oxford University Press, 2003), 2, <http://www.oxfordscholarship.com/view/10.1093/acprof:oso/9780199262168.001.0001/acprof-9780199262168>.

Taking theater architecture as a technology and the spoken drama *Guan Hanqing* by Tian Han as an example, this chapter shows how theater construction and theatrical production came to be governed by the broader logics of socialist construction and industrial production of this era.

A brief Interlude examines the Cultural Revolution “model operas” (*yangbanxi* 樣板戲) through the lens of production manuals that record in minute detail every technical element of their performance, down to the lighting cues and precise locations of actors onstage. I argue that the level of detail in these manuals creates an unrealizable ideal of perfect reproducibility that both illustrates a totalizing transformation of theater into a technology of ideology and anticipates its own technical failure.

Chapter 3, “The Multi-Medial Actor: Technique, Training, and Anti-Technology in 1980s PRC and Taiwan” offers a counter-argument to the political appropriation of the theater by way of the 1980s, when Chinese performance practice favored actor-centered theories and emphasized the immediacy of live performance. This trend, I argue, represents a reaction against both the appropriation of theater as a technology of the state during the Cultural Revolution and rapid modernization in the years following.

Chapter 4, “The Aesthetics of Technological Excess: Innovation and Intervention in Contemporary Chinese Theater,” leaps ahead to avant-garde performance of the 21st century and analyzes the ways in which directors Wang Chong and Feng Jiangzhou use live-feed projection onstage. In contrast to large-scale, high-tech spectacles like the 2008 Olympics Opening Ceremony, their work meaningfully challenges the boundaries of what constitutes “theater” and fosters a more critical attitude toward the increasing technologization of everyday life.

Ultimately, I argue that the modernization of the stage apparatus on multiple levels has enabled a reconceptualization of theater *as* a technology to be appropriated and applied in the

service of ideological goals. At the same time, I demonstrate the ways in which the very technologies that have facilitated this shift have also galvanized purely artistic experimentation and enabled new forms of critique. By emphasizing technology as material, craft, and concept more than the prevailing scholarship, my work adds a missing dimension to our understanding of the modern Chinese theater and demonstrates the importance of seemingly unimportant technicalities to the shaping of dramatic text, performance, and the work of art in/on the wider world.

Chapter 1

Technical Difficulties: Politics, Practicalities & *Play* in 1930s Shanghai Theater

On September 15, 1933, the inaugural issue of the newly minted *Xi* 《戲》 (Play) journal issued the opening salvo of its mission to build a better theater and a better theater audience for China. In strident prose-poetry, the journal's leading article decried the lack of a "pure" theater journal in China to date, championed the theater journal as an essential part of a rising theater movement (*xiju yundong* 戲劇運動), and announced, "This journal belongs to all those who toil for the theater! It belongs to all those who love the theater!"¹

The first issue of *Play* offered its broad, imagined readership an equally wide range of topics, including articles on "drama for the masses" by prominent members of the Shanghai theater scene, exhortations to attract film audiences to the theater, and a special section devoted to Soviet playwright and poet Sergei Tretiakov's (1892-1937) international anti-imperialist hit, *Riuchi, Kitai!* (Roar, China! or *Nuhou ba, Zhongguo!* 《怒吼吧中國!》) Such special sections were a common feature of the many literature and arts periodicals in circulation in 1930s Shanghai, but this one differed from the norm by publishing detailed production designs by *Roar China!* director Ying Yunwei 應雲衛 (1904-1967), lighting plots by designer Ouyang Shanzun 歐陽山尊 (1914-2009), and renderings of the set by designer Zhang Yunqiao 張雲喬 (b. 1910).² [Figure 1] Far from hypothetical, these plans depicted the actual details of a production by the

¹ Yuan Muzhi 袁牧之, "Wei xiju yundong qiantu dasuan 為戲劇運動前途打算," *Xi* 《戲》 1, no. 1 (September 1933): 1.

² Ying Yunwei titles his essay a *shangyan jihua* 上演計畫, which might be translated alternately as "performance plan" or "staging plan." However, an article from 1939 *Juchang yishu* 《劇場藝術》, reprinted in *Xiju meixue lunji* 《戲劇美學論集》, uses the English word "design" as a translation for "上演計劃," so I have adopted that

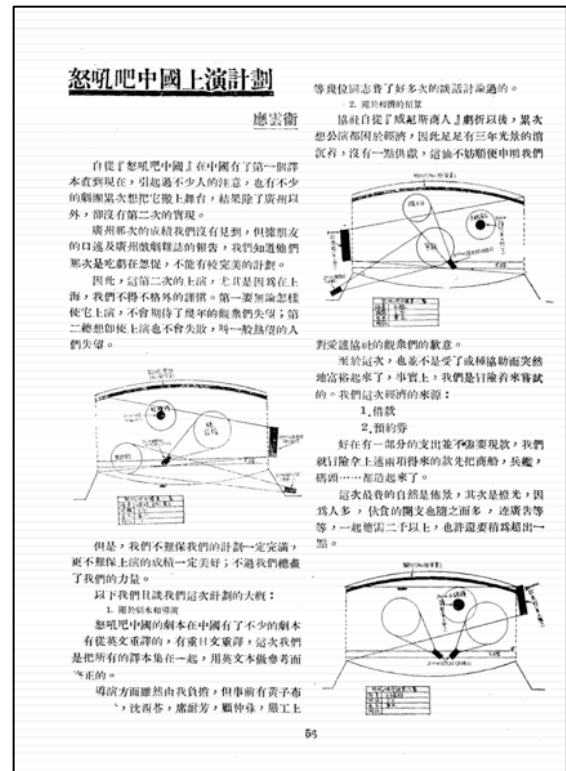
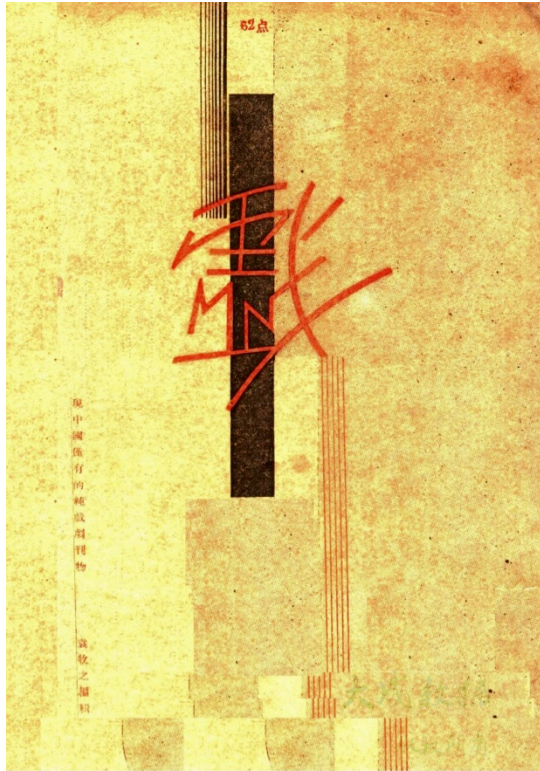

Figure 1 Cover of *Play* journal; lighting designs for *Roar, China!* (1933)

Shanghai Theater Society (Xiju xieshe 戲劇協社) that would open that very week. In fact, the journal was single-handedly edited by one of the lead actors in the production, Yuan Muzhi 袁牧之 (1909-1978), and rushed to press so that it could be distributed to audience members at performances of *Roar, China!*³ Beyond providing us with a rare glimpse into the making of a highly political spoken drama in 1930s Shanghai, this special section of *Play* thus also illustrates an unprecedented attempt by theater artists to include audiences in their production process and thereby inspire them to political actions paralleling those taking place onstage.

translation “production design” in an attempt to approximate contemporaneous understanding of the term. Ying Yunwei 應雲衛, “*Nuhoubao Zhongguo shangyan jihua* 怒吼吧中國上演計劃,” *Xi* 《戲》 1, no. 1 (1933): 58.

³ Ren Yuren 任于人, “Ping Xi 評「戲」,” *Xi* 《戲》 1, no. 2 (October 1933): 15; Yuan Muzhi 袁牧之, “Liang ji kongshou juan - jidian shengming 兩記空手拳一幾點聲明,” *Xi* 《戲》 1, no. 2 (October 1933): 21.

In the annals of Chinese *huaju* history, the 1933 Shanghai Theater Society production of *Roar, China!* stands out as a significant production both because of its political message and its revolutionary staging, highlighted by the special issue of *Play*. It inaugurated a period of serious experimentation with technical theater in the service of both artistic and political goals and laid the foundations for the first golden age of *huaju* in China, wherein modern classics like Cao Yu's 曹禺 (1910-1996) *Leiyu* 《雷雨》 (Thunderstorm) and *Richu* 《日出》 (Sunrise) would achieve new heights as both dramatic literature and well-staged plays. These new works succeeded especially in bridging the gap between form and content, employing central metaphors—a thunderstorm, a sunrise—whose realization onstage required sophisticated (for the time) manipulation of lighting, sound, and special effects. And in order to appreciate and interpret this increasingly complex integration of page and stage, audiences had to be educated through performance-specific publications, articles in the popular press, and compendia targeted at amateurs and professionals alike, like *Play*.

Anchored by this event, this chapter explores the development of revolutionary stage technologies in 1930s Shanghai by unpacking the various forms of theater at play in the production of *Roar, China!* and the accompanying special journal issue. First, it introduces *Roar, China!* via its international performance history and discusses the prominence of scenic design in the discourse surrounding the play. Then, it analyzes the way in which Chinese theater artists scripted the technical elements of *Roar, China!* to align with a particular interpretation of the play and used the special issue of *Play* as a means of calling audience attention to this revolutionary new mode of critique. Finally, it shows how the dissemination of technical information along with the performance was part of a broader trend of educating theater practitioners and audiences about technical theater, with stage lighting as a key focus, that

developed in the early-mid 1930s. Overall, this chapter argues that *Roar, China!* not only participated in the political Left turn of the Shanghai theater world, as is commonly claimed by theater histories, but also catalyzed a technical turn wherein the inner workings of the theater became a central part of theater theory, audience interest, and modernized common knowledge. As theater artists began to use staging technologies as a weapon against theatrical symbols of oppression, this knowledge became key to rendering their political actions legible, meaningful, and provocative to their audiences.

Roar, China! and China: Technologies of Spectacle and Oppression

By the time *Roar, China!* reached the stage of the Hung King Theater (Huangjin da xiyuan 黃金大戲院) in Shanghai's French concession, it had already taken the world by storm. The play shares its title with a futurist poem that Sergei Tretiakov had penned in 1924, and was inspired by his experiences living in China from 1920-1921 and 1924-25.⁴ Both poem and play chronicle the exploitation of Chinese labor by foreign capitalism and military power, but where the poem speaks largely in assonant generalities, the play is more clearly tied to a specific historic incident that took place in Wanxian 萬縣, a town on the Yangtze river, in 1924.⁵

⁴ A recent volume by Taiwanese theater scholar Qiu Kunliang collects a vast archive of primary and secondary materials and offers the most complete performance history and genealogy of the play's development over time. See Qiu Kunliang 邱坤良, *Renmin nandao meicuo ma? Nuhou Ba, Zhongguo!: Teliejiyakefu yu Meiyehede* 《人民難道沒錯嗎？〈怒吼吧，中國！〉特列季亞科夫與梅耶荷德》 (Taipei: Taipei National University of the Arts and Ink Publishing, 2013). In English, see Meserve, Ruth and Meserve, Walter, "The Stage History of Roar, China!: Documentary Drama as Propaganda," *Theatre Survey* 21, no. 1 (May 1980): 1-13; Gamsa, Mark, "Sergei Tret'iakov's *Roar, China!* Between Moscow and China," *Itinerario* 36, no. 2 (August 2012): 91-108.

⁵ Mark Gamsa notes that the play was inspired by the execution of two boatmen in Wanxian in June 1924 following the mob killing of American salesman Edwin C. Hawley, but that a much better documented incident in August-September 1926 involving the shelling of the town, which is now known as the "Wanxian Incident," heightened the contemporary relevance of Tretiakov's play. Gamsa, Mark, "Sergei Tret'iakov's *Roar, China!* Between Moscow and China," 93.

Organized in nine chains, as the acts were metaphorically termed by their author, *Roar, China!* begins when Hawley, an American leather merchant, attempts to lower the wages of his Chinese laborers and then fires them for protesting.⁶ Soon after this initial conflict, Hawley pays a visit to the captain of a British gunboat, the *Cockchafer*; on his way back to shore, he falls overboard and drowns in an altercation with the man rowing the boat carrying him. Even though the accident was caused by Hawley refusing to pay the boatman his due, the captain of the *Cockchafer* demands either the confession of the boatman involved in Hawley's death or the execution of two other (innocent) Chinese. While the villagers draw lots to determine who will die, the foreigners obliviously host an evening soiree aboard the gunboat. The boat captain refuses repeated appeals to his mercy, threatening military action against the village if they do not comply, and two Chinese men are ultimately executed in front of a crowd of onlookers. The play ends with the agitated crowd moved by these senseless deaths—and some choice words by a political agitator conveniently on the scene—to rise up and “roar” against the injustices perpetrated by their foreign oppressors.

The blatantly anti-imperialist play's premiere at the Meyerhold Theater in Moscow on January 23, 1926, directed by Vsevolod Meyerhold's (1878-1940) student Vasilii Fyodorov, received lukewarm critical reviews, but was an incredible popular success and an international

⁶ The large number of different translations of Tretiakov's play and the significance of the differences among them has been discussed at length by Mark Gamsa in “Sergei Tret'iakov's *Roar, China!* Between Moscow and China.” In my general descriptions of the play, I make every effort to focus on those major plot points/characterizations that are common across scripts and draw primarily on the 1930 British translation by F. Polianovska and Barbara Nixon, as well as various Chinese translations published between 1929-1935. Unfortunately, the production script from my primary production case study, the 1933 performances by the Shanghai Theater Society, is no longer extant. However, notes on the production by the director do state the different scripts that they consulted (the English translation, the Japanese Little Tsujiki Theater production script, and the German translation by Ruth Langer), and also that several of the play's Chinese translators were consulted for the 1933 production script. Therefore, when I find it necessary to refer to specific moments in that production, I will refer exclusively to the Chinese versions published in 1933 or after, which most closely approximate the script that was staged by the Shanghai Theater Society.

news item.⁷ Its fame grew as the Meyerhold Theater took the production on tour and theater companies in Japan, Germany, the United States, and England tried their hand at translating and performing the play.⁸ Its reputation hinged on both its political stance, which made simultaneously a favorite of Leftist theater troupes worldwide and a target of censorship, and for the radical experimentation of its performance style. Some time after seeing the touring production in Berlin, an exiled Bertolt Brecht (1898-1956) would write of Tretyakov as a model for a true revolutionary playwright: “In Russia there’s one man who’s working along the right lines, Tretyakov; a play like *Roar China* shows him to have found quite new means of expression. He has the ability, and he’s working steadily on.”⁹ In the Chinese theater world, the Japanese production by Tsukiji Little Theater (Tsukiji Shôgekijô 築地小劇場) in 1929 and the American production by the Theater Guild in 1930, in particular, drew attention, and articles by dramatists Tian Han 田漢 (1898-1968) and Tao Jingsun 陶晶孫 (1897-1952) in *Nanguo zhoukan* 《南國周刊》 (Southern Weekly) and *Lequn yuekan* 《樂群月刊》 (Monthly Social) introduced the play to Chinese readers as early as 1929.¹⁰ The first Chinese translation, based on the Japanese production script, came out that same year and Ouyang Yuqian attempted to stage the play as early as 1930 in Guangzhou, but by his own admission, the production suffered from a

⁷ Robert Crane notes that it was voted most popular play of the year by Moscow audiences. Robert Crane, “Between Factography and Ethnography: Sergei Tretyakov’s *Roar, China!* And Soviet Orientalist Discourse,” *Text & Presentation* 41 (2010): 41.

⁸ The most complete listing of productions available can be found in Qiu Kunliang, *Renmin nandao meicuo ma?*, 299–304.

⁹ Brecht, Bertolt, “Interview with an Exile,” in *Brecht on Theater: The Development of an Aesthetic*, ed. and trans. John Willet (London: Methuen Drama, 1964), 65. Original source: *Exstrabladet*, Copenhagen, March 20, 1934.

¹⁰ Tao Jinsun 陶晶孫, “‘Roar Chinese’ (juqing Lueshu 劇情略述),” *Yuequn zhoukan* 《樂群月刊》 1, no. 4 (1929): 152–53; Tian Han 田漢, “Nuhouba, Zhongguo! 怒吼吧, 中國!,” *Nanguo zhoukan* 《南國周刊》 9 (1929): 445–50; “Nuhouba, Zhongguo! (xu) 怒吼吧, 中國! (續),” *Nanguo zhoukan* 《南國周刊》 10 (1929): 491–504.

number of setbacks.¹¹ Several other Chinese theater troupes also announced plans to stage the play, and the title alone became so symbolic that it was borrowed for a number of works of nationalistic visual art and literature.¹²

From its first performance, the impressive execution of the play's scenic elements was a significant part of the discourse surrounding *Roar, China!* Tretyakov included long descriptions of the play's five main settings in published copies of the script, and articles in the international press, such as one report by *The Manchester Guardian* published on December 14, 1926, followed suit by including photographs of the large, stylized "three-dimensional set" designed for the Moscow production.¹³ These were not for show, but rather were central to the political-aesthetic mission of the production. As Robert Crane argues in a recent article, this production manipulated the placement of characters onstage and placement of key set pieces, like a massive gunboat, in order to create greater sympathy among Russian audiences for their oppressed Chinese comrades.¹⁴ At the same time, this seemingly radical scenography also proved to be easily transformed into something more realistic and spectacular, as in the New York-based Theatre Guild production designed by Lee Simonson. As an article published in *The New York Herald Tribune* describes, Simonson covered the stage with a shallow tank of water and created the illusion of a riverscape by putting partial ships on casters in the water, so they looked as

¹¹ For a list of both successful and failed Chinese performances, see Ge Fei 葛飛, "Nubouba Zhongguo! yu 1930 niandai zhengzhi zuanchuan ju 《怒吼吧，中國！》與1930年代政治宣傳劇," *Yishu pinglun* 《藝術評論》 10 (2008): 23–28; Ouyang Yuqian 歐陽予倩, "Nuhouba Zhongguo zai Guangdong shangyan Ji 《怒吼罷中國》在廣東上演記," *Xiju* 《戲劇》 2, no. 2 (October 1930): 52., reprinted in Qiu, *Renmin nandao meicuo ma?*, 633–636.

¹² For further discussion of the impact of *Roar, China!* beyond the theater in China, see Xiaobing Tang, "Echoes of Roar, China! On Vision and Voice in Modern Chinese Art," *Positions: East Asia Cultures Critique* 14, no. 2 (Fall 2006): 467–94.

¹³ "'Roar, China!' in Moscow," *The Manchester Guardian*, December 14, 1926.

¹⁴ Crane, "Between Factography and Ethnography: Sergei Tretyakov's *Roar, China!* And Soviet Orientalist Discourse," 47–48.

though they were floating and generated real waves when rolled back and forth.¹⁵ Ironically, an allergy to what was seen as relatively flat, propagandistic content among critics and audiences in places like New York may have contributed to the extent to which the details of its staging dominated reviews. For instance, Baird Leonard, the theater critic for *Life* magazine, wrote that: “Since I firmly believe that propaganda has no place in artistic entertainment, whether printed or enacted, the things that pleased me most about the Theatre Guild’s *Roar, China!* were its brevity (we were home by eleven o’clock) and its scenery”—then goes on to describe Simonson’s design at length.¹⁶ Whatever the various motivations, the inclusion of detailed comments about the sets and photographs in reviews ultimately made the technical aspects of *Roar, China!* as much a part of its international reputation as its strident anti-imperialist message.

Chinese publications participated in this trend first by reprinting photographs from foreign productions and then by circulating images from the Shanghai Theater Society production in 1933. [Figure 2] At this time, set design as spectacle was becoming increasingly familiar to certain segments of the Shanghai audience, as was the introduction of special effects as a technique of modernizing Chinese performing arts. Throughout the first decades of the 20th century, the Shanghai theater world saw an unprecedented rise in the use of electric lighting, mechanical sets, revolving stages, and even magic tricks onstage, especially in shows that catered to foreign residents or were purely commercial ventures.¹⁷ As historian Joshua Goldstein has argued, the Beijing Opera (*jingju* 京劇) and civilized drama (*wenmingxi* 文明戲)

¹⁵ “Watery Grave Snug and Warm in ‘Roar, China,’” *The New York Herald Tribune*, November 16, 1930.

¹⁶ Baird Leonard, “Theatre,” *Life* (Nov. 14, 1930): 16.

¹⁷ Goldstein, *Drama Kings*, 76. For a detailed treatment of the development of Peking Opera performance spaces around the turn of the 20th century, see Wei Bingbing, “The Bifurcated Theater: Urban Space, Operatic Entertainment, and Cultural Politics in Shanghai, 1900s-1930s” (Ph.D. Dissertation, National University of Singapore, 2013).



Figure 2 *Roar, China!* photo collage published in *Liangyou huabao* vo. 81 (1933) following performances by the Shanghai Theater Society

performances that filled new theaters built in the 1900s-1910s were heavily invested in creating a sense of novelty for their audiences. This quest for sensationalism had led to experimentation in dramatic form, composition of new scripts with topical content, and technological innovation.¹⁸ In the late 1910s and 1920s, stage technology in particular became a key selling point as even old tales of the supernatural were outfitted with flying props, pyrotechnics, and quick changes.¹⁹ Theaters displayed set renderings and models outside their doors as a way of drawing in passers-by and some advertisements even touted “mechanical sets” (*jiguan bujing* 機關布景) and special effects *over* performers, who were traditionally the main attraction.²⁰

¹⁸ Goldstein, *Drama Kings*, 91–93.

¹⁹ Wei Bingbing, “The Bifurcated Theater,” 179.

²⁰ Li Chang 李暢, “Zhongguo jindai huaju wutai meishu piantan--cong Chunliu dao wu Chongqing de wutai Meishu 中國近代話劇舞台美術片談——從春柳社到霧重慶的舞台美術,” in *Zhongguo huaju shiliao ji* 《中國話劇史料集》, ed. Zhongguo yishu yanjiuyuan huaju yanjiusuo 中國藝術研究院話劇研究所 (Beijing: Wenhua yishu chubanshe, 1987), 252–308.

A key element of their success was also the mystery that shrouded the inner workings of sudden scenic transformations. In a similar vein, the modern entertainment complexes that most often housed these spectacular Peking Opera performances also featured vaudeville, or variety show, (*zashua* 雜耍) performances that sometimes included displays of “modern Western magic” in the form of staged scientific “experiments” and devices.²¹ One example provided by Chinese historian Wei Bingbing in his recent PhD dissertation involved the ever-popular Justice Bao (commonly known as Lord Bao, or Bao gong 包公) entering a trick cabinet in pursuit of a villain, only to have numerous people suddenly rush out of the seemingly empty space.²² In such cases, the spectator’s delight came from having ocular evidence of an improbable event, knowing that it was made possible by a technical slight-of-hand yet enjoying the titillation of being tricked.

Staging *Roar, China!* in Shanghai in 1933 therefore posed several problems for the Shanghai Theater Society: first, the general association of advanced staging technologies with bourgeois, commercial theater and the practice of delighting audiences through deception was at odds with the Leftist political message of *Roar, China!* and the increasingly “proletarian” orientation of the Shanghai theater world. Second, political situation in Shanghai in the early 1930s made overtly Leftist theater productions, especially any with possible ties to the Chinese Communist Party, a precarious proposition. Finally, on a practical level, the resources and equipment required to stage the show according to international precedent presented a series of technical difficulties for the Theater Society.

In 1931, the League of Left-Wing Dramatists (Zhongguo zuoyi xijujia lianmeng 中國左翼戲劇家聯盟) formed in in Shanghai as an umbrella organization for cooperation among a

²¹ Pang, *The Distorting Mirror*, 192, 197; Wei, “The Bifurcated Theater,” 183.

²² Wei, “The Bifurcated Theater,” 180.

large group of Leftist theater artists, many of whom were also involved in Leftist literary and film projects and affiliated with the Chinese Communist Party (CCP). The League's "plan of action," passed in September 1931 and published in October, called for new revolutionary content to be produced to promote "proletarian realism."²³ With the support of communist agents in Shanghai, the League of Left-wing Dramatists sent actors into factories with the aim of raising class-consciousness through dramatic productions and to aid in strikes.²⁴ The number of workers theater troupes increased dramatically and groups such as the Blue Collar Theater Society (Lanyi jushe 藍衣劇社) formed to bring plays about the exploitation of labor and factory-related news items to university campuses.²⁵ Troupes such as the Shanghai Art Theater Society (Shanghai yishu jushe 上海藝術劇社), which was founded in 1930, primarily emphasized developing movable stages, traveling performances, and student movements.²⁶ Some of the guerilla tactics employed by this group involved planting Leftist troupes within variety programs and then coopting the performance to incite the audience, participating in activities organized by political organizations, and performing in villages outside of Shanghai.²⁷ The Leftist movement's ideological mission and activities tended to favor street performance and agit-prop theater of

²³ "Zhongguo zuoyi xijujia lianmeng zuijin xingdong gangling 中國左翼戲劇家聯盟最近行動綱領," *Wenxue daobao* 《文學導報》, no. 6-7 (October 23, 1931). Reprinted in *Wenhuabu dangshi ziliao zhengji gongzuo weiyuanhui* 文化部黨史資料征集工作委員會, ed., *Zhongguo zuoyi xijujia lianmeng shiliao ji* 《中國左翼戲劇家聯盟史料集》 (Beijing: Zhongguo xiju chubanshe, 1991).

²⁴ Ping Liu, "The Left-Wing Drama Movement in China and Its Relationship to Japan," trans. Krista Van Fleit Hang, *Positions* 14, no. 1 (Fall 2006): 461.

²⁵ Jin Shan 金山, "Huiyi Lanyi jushe 回憶藍衣劇社," in *Zhongguo huaju yundong wushinian shiliao ji* 《中國話劇運動五十年史料集》, ed. Tian Han 田漢, vol. 1 (Beijing: Zhongguo xiju chubanshe, 1958), 166–77.

²⁶ Zhao Mingyi 趙銘彝, "Guanyu Zuoyi xijujia lianmeng 關於左翼戲劇家聯盟," in *Xiju luncong* 《戲劇論叢》 (Theater Commentary), 1957, reprinted in 文化部黨史資料征集工作委員會 ed., *Zhongguo zuoyi xijujia lianmeng shiliao ji* 《中國左翼戲劇家聯盟史料集》 (北京: 中國戲劇出版社, 1991).

²⁷ Some forms used included "portable theaters" (*yidong juchang* 移動劇場), "touring public performances" (*xunhui gongyan* 巡迴公演), and the "campus theater movement" (*xuexiaoju yundong* 學校劇運動). *Ibid.*

immediacy over well-made productions like *Roar, China!* So, while the play's factographic foundation and agitational narrative seemed a natural choice for Left-leaning theater artists in Shanghai, its form was somewhat suspect.²⁸

In addition, the political orientation of Tretiakov's plot placed it in a difficult relationship with Chinese censors of the late 1920s-1930s. News of *Roar, China!* arrived in China against the backdrop of significant domestic turmoil and the aftermath of the purge of Communist forces by Chiang Kai-shek's Kuomintang (KMT) forces in spring 1927. This purge had particular significance for the theater artists living and working in Shanghai: an initial strike on March 21, 1927 by the Shanghai General Labor Union united hundreds of thousands of workers and threw the city into chaos, and a subsequent double-crossing of the labor forces by Chiang Kai-shek led to the death and imprisonment of hundreds.²⁹ This incident also caused a major break between the KMT and the CCP, leading to many more arrests of Communist Party members and stricter censorship of print matter and performances, now (often rightly) suspected of political agitation. In fact, many of the theater groups formed during this period, operated covertly and involved underground Communist agents. And while the *Roar, China's* anti-imperialist message in fact resonated with the strong nationalistic ethos underlying both parties, its direct injunctions against American capitalism and British military intervention in domestic affairs posed a problem for the KMT as it increasingly depended upon foreign assistance to combat advancing Japanese imperialism.

²⁸ The ideological-aesthetic theory behind Tretiakov's play, factography or *fakto-grafia*, was a concept developed in the late 1920s within a Soviet artistic movement, led by none other than Tretiakov. The central idea was to formulate an artistic praxis based on the "claim not to veridically reflect reality in his work, but to actively transform reality through it." Devin Fore, "Introduction to Special Issue on Soviet Factography," *October* 118 (Fall 2006): 3–4.

²⁹ For a basic overview of the "Shanghai Spring," see Jonathan D. Spence, *The Search for Modern China*, 2nd ed. (New York: W.W. Norton, 1999), 350–353. For more detail on the Shanghai strikes, see Elizabeth Perry, *Shanghai on Strike* (Stanford, CA: Stanford University Press, 1993).

The courage of the Theater Society in producing *Roar, China!* under such circumstances has become a key part of the play's historical narrative in Chinese scholarship, which casts it as a key part of the early 1930s proletarian theater movement. Left-wing theater organizations – even the CCP itself – are credited with promoting it. For example, the *Zhongguo zuoyi xijujia lianmeng shiliao ji* 《中國左翼戲劇家聯盟史料集》 (Collected Historical Material on the Chinese League of Left-Wing Dramatists) includes a reference to the play in its introduction, noting that its anti-imperialist message caused a sensation among audiences, and the seminal *Zhongguo huaju yundong wushi nian shiliao ji* 《中國話劇運動五十年史料集》 (Collected Historical Material on Fifty Years of the Chinese Huaju Movement) likewise frames the production as a success of Leftist politics.³⁰ Encyclopedias like the *Shanghai huaju zhi* 《上海話劇志》 (Shanghai Huaju Gazetteer), perhaps drawing on these sources, state an even more direct relationship between the League of Left-Wing Dramatists and the production of *Roar, China!*³¹ Likewise, more recent scholarly research by authors Qiu Kunliang, whose impressive volume on *Roar, China!* collects historical materials on nearly every production of the play since its premiere, and Ge Fei unquestioningly characterize the play as an appendage of Leftist politics. The focus of this chapter is not to quibble with the historiography; however, the analysis that follows will demonstrate that the interaction between politics and theater was acted out onstage in a much more sophisticated, and much more technical, way than has been previously acknowledged.

³⁰ Lu Fu 呂復 and Wang Yongde 王永德, “Zhongguo zuoyi xijujia lianmeng jianjie 中國左翼戲劇家聯盟簡介,” in *Zhongguo zuoyi xijujia lianmeng shiliao ji* 《中國左翼戲劇家聯盟史料集》, ed. Wenhua bu dangshi ziliao zhengji gongzuo weiyuanhui 文化部黨史資料征集工作委員會 (Beijing: Zhongguo xiju chubanshe, 1991), 2.

³¹ Li Xiao 李曉, ed., *Shanghai Xiju Zhi* 《上海話劇志》 (Shanghai: Baijia chubanshe, 2002), 94.

Beyond these problems of politics, the very technical prowess demonstrated by international productions and necessary to effectively stage the play became a technical difficulty when introduced into the Chinese theater world. The former problem was solved by the largely conciliatory attitude toward bourgeois entertainments that the Chinese Left adopted in the late 1920s and early 1930s. Even as modern theater technologies and the display of science onstage were decried for preying upon audience desire for superficial wonderment, organizations like the League of Left-Wing Dramatists (Zhongguo zuoyi xijujia lianmeng 中國左翼戲劇家聯盟) also encouraged their members to critically appropriate the most popular forms to communicate their political messages to broader audiences.³² As scholars such as Laikwan Pang and Andrew Jones have shown, Chinese Leftists made similar moves in the arenas of fiction, film, and popular music, appropriating the apparatuses of popular culture even as they fought against the commercial presses, Hollywood studios, and “yellow music” recording industry that controlled the market.³³ The movement toward more proletarian arts was already in motion, but the wholesale rejection of the culture industry was still yet to come.

The problem of technical capabilities was more immediate and more challenging to overcome. With a few exceptions, the Chinese theater troupes that performed foreign plays in the 1920s-1930s were largely student drama clubs or quasi-amateur outfits without the means to match the production value of a Broadway show. They were well aware of the various scenic interpretations of Tretiakov’s play and aspired to reproduce them as faithfully as possible, but

³² Formed in January 1931 in Shanghai, the League was affiliated with the Chinese Communist Party (CCP) and offered an umbrella for cooperation among a large group of Leftist theater artists, many of whom were also involved in Leftist literary and film projects. The League’s “plan of action,” passed in September 1931 and published in October, emphasized “proletarian realism” and guerilla agit-prop tactics. However, it also allowed for the use of more mainstream forms, for a time. See “Zhongguo zuoyi xijujia lianmeng zuijin xingdong gangling,” 17.

³³ Andrew Jones, *Yellow Music: Media Culture and Modernity in the Chinese Jazz Age* (Durham, NC: Duke University Press, 2001); Laikwan Pang, *Building a New Cinema in China: The Chinese Left-Wing Cinema Movement 1932-1937* (Lanham, MD: Rowman & Littlefield, 2002).

with limited means. For example, one of the early published descriptions of the play was based on the notes of a female member of Tian Han's Southern Society, Li Yunying 李雲英, who purportedly attended a performance in Moscow. This description, coupled with a Japanese translation of the script, may have informed Ouyang Yuqian's production in Guangdong. Ouyang's *Roar, China!*, however, is far from a success story; the director later reported that several of their scene changes took as long as the scenes themselves and largely faulted the lack of appropriate stage machinery for the play's lackluster execution.³⁴

The subsequent production by the Shanghai Theater Society in 1933 drew lessons from both Ouyang's experiences and further materials on foreign productions, such as a production photograph from the New York performances in Sun Shiyi's 1931 overview of the play and photographs of the Japanese Little Tsujiki Theater performances circulated in *Maodun yuekan* 《矛盾月刊》 (Contradiction Monthly) in 1933.³⁵ Set designer Zhang Yunqiao also recalls that a review of the Theater Guild production in *Life* magazine and accompanying "production photos" (*juzhao tupian* 劇照圖片) provided the basis for director Ying Yunwei's artistic vision.³⁶ At the time, however, *Life* magazine was an illustrated periodical that did not publish photographs per se; rather, its theater reviews section was usually accompanied by caricatured sketches of actors or scenes from the week's most popular Broadway productions. [Figure 3] If Ying Yunwei did indeed base his production on this sketch, then his *Roar, China!* ironically risked reproducing a mockery of the very ideal it attempted to imitate.

³⁴ Ouyang Yuqian "Nuhouba Zhongguo zai Guangdong shangyan ji," 52.

³⁵ Ibid.

³⁶ This detail is mentioned in several articles on this production, including in a personal essay published by set designer Zhang Yunqiao. Zhang Yunqiao 張雲喬, "Ying Yunwei he huaju Nuhouba, Zhongguo! 應雲衛和話劇《怒吼吧，中國！》," *Shanghai tan* 《上海灘》 7 (1995): 38–39.



Figure 3 Illustration from *Life Magazine*
(Source: *Life Magazine* [November 14, 1930], 16)

The result, however, was both serious and successful. As the production design notes, set renderings, and later production photographs demonstrate, the Shanghai Theater Society performances of *Roar, China!* featured a series of large set pieces and well-choreographed transitions.³⁷ The British gunboat, American merchant ships, pier, and a wireless tower were all built to scale and were, if not entirely realistic, certainly functional. [Figures 4-6] Lighting designer Ouyang Shanzun had ten “spotlights” (*juguangdeng* 聚光燈, also translated as “focus lights”) at his disposal and handmade three dimmers to control them. Supplies for these set pieces and the lighting equipment required to orchestrate eight blackout scene changes ran the budget up to 2000 *yuan*, an amount so exorbitant at the time that Ying felt the need to devote an

³⁷ Ying Yunwei, “*Nuhoubao Zhongguo shangyan jihua*,” 58.

戲劇協社演出怒吼吧中國的佈景圖樣

張雲喬

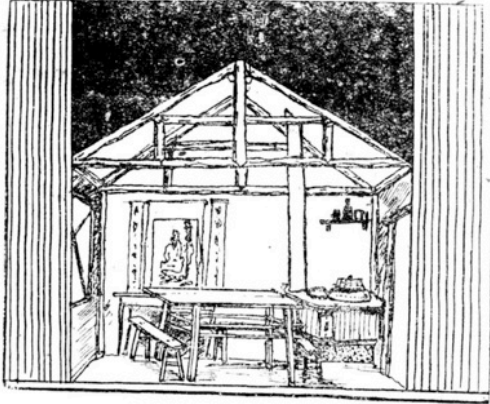

第六八景

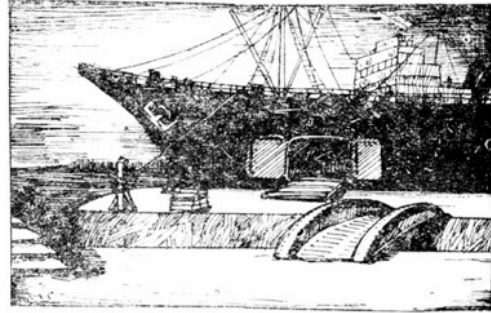

第一景

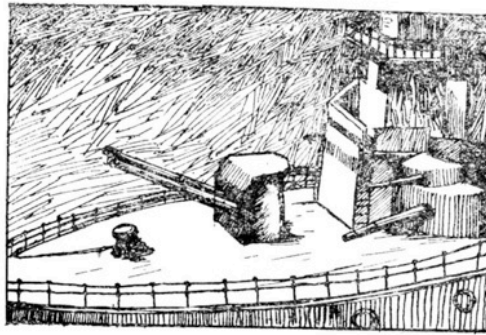

第二四七景



第三五景

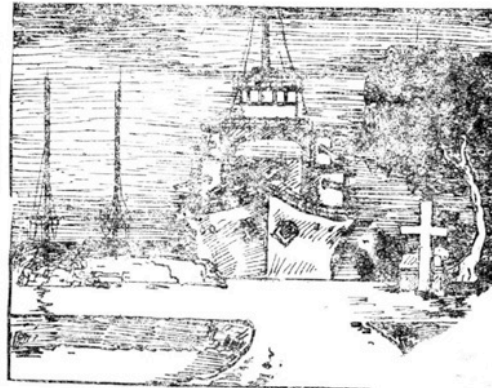

第九景

Figure 4 Set designs by Zhang Yunqiao (Source: *Xi* 1, no. 1 [September 1933])

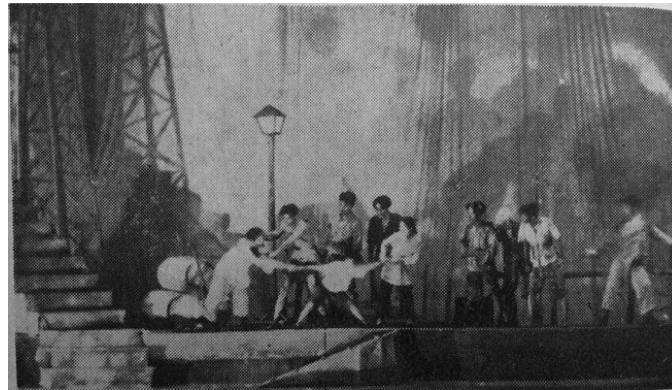
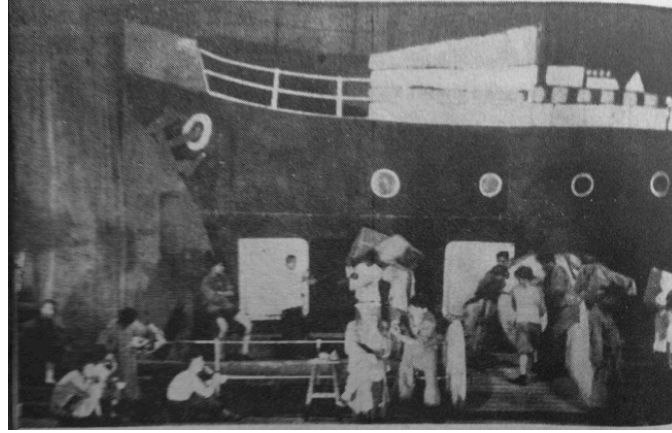

Figures 5-6 Production photos from Theater Society performances in September 1933. (Source: *Nuhouba, Zhongguo!*, Shanghai: Liangyou tuhua yinshua gongsi, 1935)

entire section of his staging design to justifying his fundraising strategy.³⁸ However, the investment proved worth it when the 30 or so stage hands succeeded in reducing the scene change time to only three-to-four minutes, a stark contrast to Ouyang Yuqian’s dragging transitions. While not as technically sophisticated as Lee Simonson’s floating sampans, the size and complexity of coordination of the Shanghai production sets were just as much a novelty and just as impressive to their local audiences as were Simonson’s to his Broadway patrons.

³⁸ As theater scholar Ma Junshan has noted, lighting equipment at this point had to be imported, so the cost of anything more than the most basic equipment was usually prohibitive. Ma Junshan 馬俊山, “Yanju zhiyehua yundong yu Zhongguo huaju wutai meishu de chengshou 演劇職業化運動與中國話劇舞台美術的成熟,” *Shanghai xiju xueyuan xuebao* 《上海戲劇學院學報》 4 (2005).

Mobilizing Technical Critique Onstage

The use of large-scale sets and quick changes in the Shanghai Theater Society production of *Roar, China!* was not, however, merely about impressing the audience or participating in an international mode of staging Tretiakov's play. From the juxtaposition of lighting unit diagrams and production design notes published together in *Play*, we can see that technical ingenuity also operated on another level: in the physical shifting of lighting units necessitated by working with only ten lighting units and three dimmers. [Figure 7] Illuminating the means of illumination, Ying's notes gloss the diagrams with the following comment:

Typically, the lights are installed after the sets have been put up (referring to the small elements, like wall lamps or table lamps), but that doesn't work this time. The lights have to be changed during the blackout along with the sets. Our method is to hang the spotlights so that they can move, then use a rope of a certain length to guide it to a specific spot, and likewise with the dimmers. And once the blackout reaches a certain point, they turn on.

平常的燈光總在佈景搭就以後才裝置（指細小的部分，如壁燈，台燈等），這次可不行了，燈光將和佈景同樣在暗中變換。方法是使 Spotlight 活動地掛著，用一定長短的繩子支配它到一定的地位，Dimmer 也一樣，在暗中由一定的程度再轉亮³⁹

Comparing the various diagrams published in Ying's production design notes with the number of lighting units he claims to have used, it does indeed seem that some of the "spotlights" switched location or direction between scenes. This movement of equipment gestures not only toward the technical innovation of the performance, but also to the labor hidden behind the schematic

³⁹ Here it is worth noting that in even though he uses the English word "spotlight," Ying likely did not refer to the high wattage, long-throw spotlights today used to follow individual performers with a sharp circle of light. Rather, the *juguangdeng* 聚光燈 (also translated as "focus light") probably denotes single-bulb lighting units used to create areas of light onstage. Ying Yunwei, "Nuhoubao Zhongguo shangyan jihua," 59; He Mengfu 賀孟斧, *Wutai zhaoming* 《舞台照明》 (Shanghai: Shangwu yinshua guan, 1936), 29.

怒吼吧中國上演計劃

應雲衛

自從『怒吼吧中國』在中國有了第一個譯本直到現在，引起過不少人的注意，也有不少劇團累次想把它搬上舞台，結果除了廣州以外，卻沒有第二次的實現。

廣州那次的成績我們沒有見到，但據朋友的口述及廣州戲劇雜誌的報告，我們知道他們那次是吃虧在匆促，不能有較完美的計劃。

因此，這第二次的上演，尤其是因為在上海，我們不得不格外的謹慎。第一要無論怎樣使它上演，不會期待了幾年的觀眾們失望；第二總想即使上演也不會失敗，叫一般熱望的人們失望。

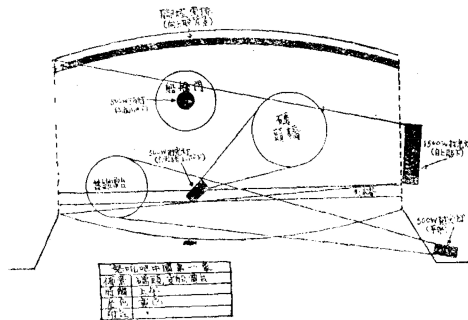

但是，我們不難保我們的計劃一定完滿，更不難保上演的成績一定美好；不過我們總盡了我們的力量。

以下我們且談我們這次計劃的大概：

1. 關於劇本和導演

怒吼吧中國的劇本在中國有了不少的劇本有從英文重譯的，有重日文重譯，這次我們是把所有的譯本集在一起，用英文本做參考而修正的。

導演方面雖然由我負擔，但事前有黃子布，沈西荅，席耐芳，顧仲彝，嚴工上

等幾位同志費了好多次的談話討論過的。

2. 關於經濟的預算

協社自從『威尼斯商人』虧折以後，累次想公演都困於經濟，因此足足有三年光景的消沉着，沒有一點供獻，這油不妨順便申明我們

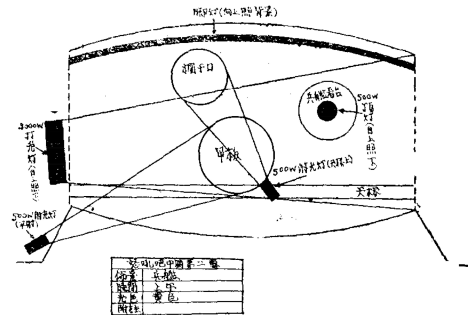

對愛護協社的觀眾們的歉意。

至於這次，也並不是受了或種協助而突然地富裕起來了，事實上，我們是冒險着來嘗試的。我們這次經濟的來源：

1. 借款

2. 預約券

好在有一部分支出並不需要現款，我們就冒險拿上述兩項得來的款先把商船，兵艦，碼頭……都造起來了。

這次最費的自然佈景，其次是燈光，因為人多，伙食的開支也隨之而多，連廣告等等，一起總需二千以上，也許還要稍為超出一點。

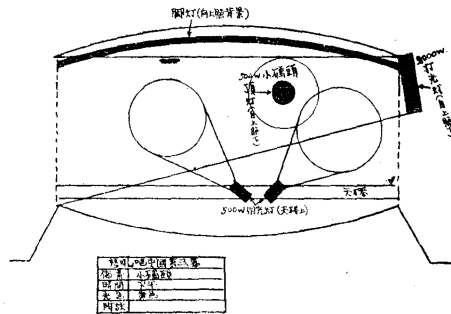

Figure 7 Scene-by-scene stage diagrams with lighting equipment, published in *Play* (Source: Ying Yunwei, "Nuhouba Zhongguo shangyan jihua," *Xi* 1, no. 1 [September 1933])

diagrams that Ying provides. In another part of his production design, Ying calls the audience's attention directly to this issue, noting a correspondence between the expensive scenery and lighting required by the production and the necessity of asking actors and stagehands to labor through three performances per day to avoid losing money.⁴⁰ Praising the stagehands in particular as the “unsung heroes” (*wuming yingxiongmen* 無名英雄們) of the play, Ying uses the technical aspects of the stage design to call attention to that which *ought* to remain unseen: the people moving and operating the lighting equipment and set pieces.

This blackout quick change, propelled by the labor of 30 stagehands, in fact constituted the greatest aesthetic and technical intervention of the production. The term that Ying Yunwei uses for quick change throughout his notes, *qiangjing* 搶景—to literally “snatch” the “scenery”—suggests an imperative of speed and force in these set changes.⁴¹ Indeed, no curtain fell to interrupt the progression of the play; rather, the stagehands moved large set pieces in full, if darkened, view. In the words of one reviewer, the director's success at reducing the complex changes to only 3-5 minutes each “could be considered the dawning of a new era for spoken drama.”⁴² Compared with Ouyang Yuqian's early attempt to stage the play, wherein the set change length exceeded the length of some scenes, this was certainly an improvement; however,

⁴⁰ Ying Yunwei, “*Nuhoubao Zhongguo shangyan jihua*.”

⁴¹ The term would have been new to its readers, given that *Roar, China!* was one of the first productions to attempt this type of transition and the term does not commonly appear in print until the mid-1930s. Claims to historical “firsts” ought be taken with a grain of salt, but the *Shanghai huaju zhi* 《上海華聚志》 (Shanghai Spoken Drama Gazetteer) does list *Roar, China!* as the first spoken drama production in China to attempt a blackout quick change with no curtain. Text searches of digitized *Shenbao* also show the term first used in 1935, in reference to *Roar, China!* *Shanghai huaju zhi* 《上海話劇志》, s.v. “Xiju xieshe 戲劇協社” (Shanghai: Baijia chubanshe, 2002), 94; *Shenbao* 《申報》 Erudition Online.

⁴² “Suanshi kai huaju jie de xin jiyuan le 算是開話劇界的新紀元了”; Bi Bo 碧波, “Kan Nuhouba, Zhongguo! zhi hou 看「怒吼吧，中國！」之後,” *Shanhu* 《珊瑚》 3, no. 9 (1933): 6.

it is not only the speed, but also the mechanics, of the changes that truly deserves note. Set designer Zhang Yunqiao would later describe the sets as follows:

In order to think about the method of doing a quick change concretely, I built a set of small models, then Mr. Ying and I fiddled around with them for several nights. Mr. Ying came up with the idea of dividing the entire warship into two parts, which could be joined together to form the ship or separated to form two ship berths. And after they were separated, they could be turned around to become the stairway for the exterior dock scene. During the blackout change, we would just need several stagehands to work together to turn the ship around, and we'd have the dock set. The other stage hands could then split up the other tasks to return the other parts (the ship railing, the gun turret hanging down from overhead) to their original positions. When the lights came up, the changed scene and lights were already in place.

為了便於思考怎樣快速換景的具體方法，我制成了一套小型模型，然後可應先生二人經過幾夜的反覆擺弄思考，應先生終於想出將兵船的整個船台，中間分開制成兩個部分，可合攏成整個船體，也可以分開兩個船台，分開翻過身就是碼頭外景的台階。再黑暗中換景之時，只要由幾個工人合力把船台翻轉，就變成碼頭邊外景，其他工作人員，也預定各自分工，把部件（船台欄杆，炮塔從上面吊下）歸位，等燈光復明之時，場景已經換燈好⁴³

Recalling how the stagehands required a week of nearly all-night rehearsal to perfect the transitions, Zhang Yunqiao further hints at a parallel between actor and stagehand at work in this production; the quick changes were no less a performance than that of the actors after lights up.⁴⁴ This elision of roles opens up the possibility of reading these quick changes not as mere technical feats, but rather an integral part of the performance. As such, they become actions that can be invested with meaning, by the director and designers, and open to interpretation by the audience.

What the stagehands did, after all, was nothing less than deconstruct massive symbols of foreign imperialism—disassembling and reconfiguring an imposing hunk of British gunboat—right in front of the audience. This dismantling in turn served to highlight and heighten the ways

⁴³ Zhang Yunqiao, “Ying Yunwei he huaju *Nuhouba*, *Zhongguo!*,” 38.

⁴⁴ *Ibid.*, 38–39.

in which within the play itself these symbols of imperialism were already linked to technologies, specifically the military and communications technologies that enabled imperialism. The first and most obvious example of this can be found in the British military gunboat anchored in the Yangtze River, which appears in the stage directions and which many productions chose to foreground. In all cases, the design of the gunboat corresponds roughly to a historically accurate representation of the kind of British naval vessels anchored in the Yangtze River in the 1920s-1930s. Equipped with engines and machine guns, these vessels—and their theatrical doppelgangers—represented not only imperialist military expansion and oppression in general, but also the specific incursions of mechanized military equipment in the post-World War I era. Modernization of this era is further represented by a wireless tower, which could appear onstage in as many as four scenes, and several episodes involved photography. On one level, the wireless station belongs to the same network of military technologies as the gunboat; in the final scene, the British captain of the gunboat receives (and disregards) an important message from his superiors via telegraph (*dianbao* 電報). At the same time, the term *wuxian diantai* 無線電台 and the actual large prop used onstage suggest a radio station and radio tower, rather than the simpler telegraph. This nod to radio, as well as several instances of photography used onstage, suggests bourgeois modern life and offer a clear contrast to the living conditions of the play's laborers and boatmen, who would not even participate in modern industrial production.

The play's representation of these technologies, however, is not purely symbolic or comparative. Rather, their usage is subtly woven into the plot at key moments. The first instance takes place during the disagreement between Hawley and his workers. According to the text, one laborer approaches him menacingly, a nearby tourist and his wife snap a photograph. The gesture is intrusive and insensitive, but ultimately harmless, and guides quickly lead the tourists away

from the scuffle and on to a nearby historic site. The play makes clear, however, that such naïve voyeurism is an iteration of a much more troubling impulse; the next time we see a camera onstage is in Act 7 only moments after a young Chinese serving boy on the British gunboat takes his own life. The stage directions script the suicide to happen onstage and the boy's lifeless body to be found hanging from the captain's bridge by Cordelia, daughter of Hawley's business partner and a guest onboard the gunboat. After recovering from her initial shock and calling the ship's lieutenant, she says: "I'm all right now. Do you think you could get me my camera and some magnesium? It would make a marvelous photograph!"⁴⁵ The camera becomes the apparatus by which Cordelia transforms unjust death into beauty, staging another level on which modern technologies function as implements of oppression in the wrong hands. This moment is mirrored only two scenes later, when a foreign journalist working at the radio station moves grieving Chinese onlookers aside to take a photograph of the two wrongly executed Chinese men. He quips: "It'll be quite a scoop!" Exceeding the ignorance of the tourists and Cordelia's fascination with morbid beauty, he directly instrumentalizes the deaths of the Chinese and attempts to transform them into a mechanically reproduced spectacle for the global news circuit. However, a political agitator from Canton, who has been encouraging the local laborers to unionize throughout the play, physically blocks the journalist's lens. In a move that seems counterintuitive given Tretiakov's reputation as a futurist poet, his play uses the human body to halt the workings of technologized oppression. And when the masses of Chinese boatmen and laborers begin to mobilize against the British military captain and his supporters at the end of the

⁴⁵ The episode of the boy's suicide was one of the most acclaimed moments in the Meyerhold Theater production, but is curiously abbreviated in the translated Chinese scripts published around the time of the Theater Society production. In Pan Jienong's translation, for example, the stage directions describing the suicide are cut, leaving only the sudden discovery of the already-deceased boy and the commotion surrounding the discovery of his body. The lines about the camera, however, remain in tact. Sergei Tretiakov, *Roar, China!*, trans. F. Polianivska and Barbara Nixon (London: Martin Lawrence, 1931), 74.

play, it becomes clear that the best weapon is, after all, pure and unmediated human resistance. The masses are at once become a technology of revolution and exceed the potentials of mere mechanics.

The wireless tower also offers a curious contrast to the visceral auralty of the play's title. Unlike the "roar" of the Chinese, which we hear only at the very end of the play, the looming wireless tower represents a mechanical reproduction of sound and voice. This link between an imperative to cry out and the use of mechanical means to promulgate that imperative has been discussed at length by art historian Tang Xiaobing in his article on representations of *Roar, China!* in the Chinese woodblock print movement of the 1930s.⁴⁶ Focusing on images that anthropomorphize the anguished nation as tortured, wailing bodies, Tang calls attention to the way in which the politics of national awakening and international solidarity moved visual artists to transgress boundaries between the visual and the aural, as well as to attempt to make their viewers into active agents of social and political change. This process occurred both through the depiction of anguished bodies and as part of what Tang calls a "multimedia project," which involved not only the woodcut prints but also translations of Tretiakov's poem and play, summaries, reviews, commentary, and the "design blueprints" of the sets for the Shanghai Theater Society production. Writing of the woodcut print by Li Hua that borrows its title from Tretiakov, Tang writes: "In short, the deepest conviction of *Roar, China!* is that conventional poetics of seeing must be translated and transformed into an empowering politics of speaking and voicing."⁴⁷

What is particularly useful about Tang's mode of analysis is the way he frames

⁴⁶ Tang, "Echoes of Roar, China!"

⁴⁷ *Ibid.*, 279.

“literature, visual arts, and acoustic devices” as “mobilizing technologies”; in some respects, the theater also fits the bill as an “as effective a force in engineering and instituting modernity in China as visuality and writing.”⁴⁸ However, what stands out about the production of *Roar, China!*, in contrast to the works of visual aurality discussed by Tang, is the way in which it at once borrows the utility of technology and directly counters the oppression perpetrated by means of technology. The Shanghai Theater Society production of *Roar, China!* presents for its audiences two stories: one narrative of oppression, designed to agitate its viewers into action, and another of agency, enacted through the manipulation of stage elements. This was not potentially chaotic violence that threatens at the end of the play, when its diegetic Chinese masses begin to rise up against their foreign oppressors. Rather, it was a tightly managed and controlled display of strength used to mobilize the physical pieces of scenery. Thus, where the Meyerhold Theater production had used the direction of the gunboat’s weaponry to create a sympathy between the audience and the oppressed masses onstage, and where Lee Simonson had borrowed a propaganda piece to play with spectacular floating set pieces, the Shanghai Theater Society asserted the power of the masses by putting well-orchestrated labor on display.

The Shanghai Theater Society production’s active use of design and scripting of transitions in order to highlight the play’s themes of technological oppression and mass mobilization therefore may be considered what Christin Essin has termed “scenographic activism”: “a process of dramaturgical interpretation, visual representation, and material practice that meaningfully supports the actions and objectives of social movements or organizations dedicated to a progressive political agenda.”⁴⁹ In her discussion of the Federal Theater Project

⁴⁸ Ibid., 282.

⁴⁹ Essin, *Stage Designers*, 95–96.

(FTP) in the United States, Essin in fact highlights one strikingly similar instance of staging theater technology, in a production of *Power* at the Ritz Theatre in 1937. In this particular production, Essin argues, director Brett Warren used actors as stage hands in a Brechtian attempt to blur the lines between the two, while actor Robert Novack's performance of an "Electrician" functioned to give spectators "an empathetic understanding of backstage labor and technology as more than just the mechanism behind the performance."⁵⁰ A similar impulse can be seen at work in the Theater Society production of *Roar, China!*, but the political thrust of emphasis on stage labor takes a slightly different direction. Where the American FTP and its performances of *Power* espoused a progressive labor politics, calling attention both to the labor of the theater and the labor of electricity production, the Theater Society mobilizes in support of a more nationalistic agenda.

This reading of *Roar, China!* alongside its Shanghai staging raises the question of whether so technical a critique would have been intelligible to Chinese audiences of the 1930s, especially those attending performances of *Roar, China!* While the Shanghai Theater Society and the League of Left-Wing Dramatists may have broadly advocated targeting more proletarian audiences, the type of theater used for this particular production and its ticket distribution method suggest a more bourgeois orientation. Advertisements for *Roar, China!* that ran in the *Shenbao* 《申報》 in September and October 1933 show that its financial support, at least, came from elsewhere. On the day that the first *Roar, China!* ad ran in *Shenbao*, it was accompanied (on a different page) by an advertisement for the Shanghai Domestic Products Company (Shanghai guohuo gongsi 上海國貨公司) on Nanjing Road that announced: "Giveaway! Tickets

⁵⁰ Ibid., 126.

to the Theater Society's *Roar, China!* at the Hung King Theater."⁵¹ For loyal customers who purchased either a pound of embroidery floss (*rongxian* 絨線) or five *yuan* 元 worth of any products, the store would gift them with a free five *jiao* 角 ticket to the play.

Moreover, the fact that the five *jiao* (or one half *yuan*) were the cheaper of the two ticket prices—half *yuan* for open seating and one *yuan* for reserved seating—also suggests that there was a commercial aspect to the production and points to a certain level of affluence among audience members. While not exorbitantly expensive, the tickets for *Roar, China!* were on the upper end of the spectrum, despite efforts to sell as many tickets as possible at the lower price point.⁵² And indeed, some Leftist critics expressed confused skepticism about the political orientation of the production. One review writes: "As for the production done by the Theater Society at the Eight Immortals Bridge Hung King Theater – the fact that the Theater Society chose this play is highly unexpected [lit. exceeded all expectations] and in some respects hard to understand, because it is *this* kind of a play, and the Theater Society to date has been *that* kind of a theater troupe."⁵³ Here, the ambiguous "this" and "that" may perhaps refer to the flashy nature of the production and the previously political reputation of the theater troupe. The critic goes on to complain about the production's audience of "male spectators in Western-style suits and Sun

⁵¹ *Shenbao* 《申報》 1933.09.15, Erudition online database

⁵² As a point of comparison, other advertisements on the same page of *Shenbao* lists prices of six *jiao* or one to one-and-a-half *yuan* for daytime screenings of Noel Coward's film, *Cavalcade* at the Nanjing da xiyuan 南京大戲院 (Nanjing Grand), but a tiered ticketing scheme of only two *jiao* to eight *jiao* for another theater performance, *Xin xiangshi'an* 《新箱屍案》 (The New Case of a Body in a Trunk) at the Xianggang da xiyuan 香港大戲院 (Hong Kong Grand, see *Shenbao* 《申報》 1933.09.15, Erudition online database; on ticket sales, Ying Yunwei, "Nuhoubao Zhongguo shangyan jihua," 58.

⁵³ San Wen 三文, "Nuhouba Zhongguo! 怒吼吧中國! ," *Shiri tan* 《十日談》 5 (1933). 大成老旧刊全文数据库 database.

Yat-sen suits, female spectators in high heels and cheongsams,” especially their affected responses to the play and misinterpretation of its message.

Assuming that this average patron of the Hung King Theater in 1933 Shanghai—petty bourgeois and quite fashionable, if we believe the above complaints—would not have been well-versed in technical theater, we might return to the copy of *Play* that he or she received upon arriving at the Shanghai Theater Society performance and hypothesize that the published production design, lighting plots, and set drawings included therein offered a kind of guide to their audience-readers. We might imagine, for example, that an audience member enters the theater, presents a ticket (which he or she perhaps received free from the Shanghai Domestic Products Company), and takes the journal from an usher, like a contemporary playbill. *Play* in hand, the audience member takes a seat and in the remaining minutes before the play begins, they flip first to the special section on the performance at hand. They skim through Sun Shiyi’s introduction and the translation of Tretiakov’s playwright’s note before coming to Ying Yunwei’s staging plan. There, they get a preview of the sets and lights, now knowing what to expect from each scene and where the light will be shining. They also gain an appreciation of the labor that it took to prepare for the play and will take to do the set changes in front of them. They start to anticipate seeing a brand new technique, the “quick change,” that the notes describe.

Similarly, even if audience members received a copy of the journal as they exited the theater, they might carry it home with them and find themselves drawn to the section on the play they have just watched. Reading the articles and looking at the drawings gives them a heightened appreciation for the complexity of the technical spectacles that they’ve just witnessed. The paper document begins to script and mediate audience members’ memory of their theater-going experience. It tells them to remember the production as centered around the quick changes and

lighting design. And much later, after the production script and many photos are lost to history, the drawings will tell future generations of theater directors, designers, and scholars more about how the stage apparatus worked for *Roar, China!* than for any other production of the period.

On the other hand, we may perhaps read this in this provision of unfamiliar, technical details an impulse akin to the radical separation of theatrical elements advocated in Bertolt Brecht's early writings on the epic theater.⁵⁴ Ying Yunwei's article, in particular, breaks down the production process into discreet segments: (1) script and director, (2) budget, (3) actors, (4) scenery, and (5) lighting. The lighting diagrams and set drawings further call attention to elements that are typically spatially or temporally removed from the audience; lighting units, with a few exceptions, remain hidden in the wings and fly space, and set drawings must necessarily precede and transform into the scenery that appears before the audience. By lifting the curtain on and explaining otherwise magical elements of the theater the information in *Play* may actually have disaggregated and defamiliarized the play in a manner similar to Brechtian theater's discrete use of music, projections, and stylized acting to provoke critical reflection and create the estrangement effect among his audience members.

In either case, the printed text asks its readers to experience (or recall) the live performance in a particular way. It provides background information that frames the content of the play and technical information that guides their attention to certain elements of the production. In a purely commercial production, like a vaudeville or variety show performed at Shanghai entertainment complexes, the emphasis on the scenery and lighting might be read as an attempt to sell tickets by trumping up the novelty of the production. However, with the exception of its introductory manifesto, the language of writing in the journal is not that of a sales pitch,

⁵⁴ Bertolt Brecht, "The Modern Theater Is the Epic Theater," in *Brecht on Theater: The Development of an Aesthetic*, ed. and trans. John Willet (London: Methuen Drama, 1964), 37.

and the amount of detail provided far exceeds what would be necessary to impress the uninitiated. For example, in addition to including the aforementioned dimmer article by Ouyang Shanzun—which with its section devoted to the basic question of “what is a dimmer?” clearly targets a lay audience—the lighting plots indicate to a careful audience-reader which set pieces and parts of the scene were deemed important enough to be illuminated and how the lighting would shift between scenes. They are, in short, a set of cliff notes for reading the movement of lighting in the production. These notes functioned as a decoding rubric for audiences that rendered legible the message latent in the production’s use of stage technology; without their issue of *Play* in hand, audiences might be mesmerized or manipulated by technical mastery, but with it, they were given the tools to a whole new level of interpretation.

The Revolutionary Potential of Technical Theater

The co-presentation of *Roar, China!* and *Play* not only stands as a significant case in the extent of the technical details laid bare for audience members, with the help of a print publication, but also marks a turning point toward an increasingly close cooperation among political orientation, aesthetics, and technical aspects of modern Chinese theater. While commercial theater was already invested in the technologies of spectacle, at the time when *Roar, China!* was staged in 1933, more revolutionary Chinese theater makers were just beginning to come to terms with the importance of the technical side of the theater to their political-artistic mission. Here again, *Roar, China!* is significant; in an essay on the successes and shortcomings of his Guangdong production, Ouyang Yuqian writes:

A certain type of play requires a certain type of stage, and a certain kind of stage will have a certain type of play. Without the efforts of the New Romantics and the full use of machinery, the Expressionists and the Futurists would not have had a starting point for

their performances. Many new forms of performance cannot be done without a well-equipped stage.

有甚麼樣的戲，便要有甚麼樣的舞台，有甚麼樣的舞台，便有甚麼樣的戲。倘若沒有新浪漫派的努力，機械的運用部充分，那表現派和未來派的戲便無從演起，許多的新演出法，沒有完備的舞台，也是沒有辦法的。⁵⁵

Clearly aligning himself with the more avant-garde impulses of the Expressionists and the Futurists, Ouyang's comment demonstrates his sudden realization that shifts in form rely upon technological developments achieved by more conservative predecessors and that radical aesthetics—and politics—cannot be divorced from the more mundane concerns of machinery and equipment. Without a well-provisioned stage, the aesthetic and political missions of a play might remain unrealizable.

Nor were Ying Yunwei and Ouyang Yuqian the only Left-leaning theater artists of their period to suggest that audiences and artists alike pay attention to the connection between the technical realization of aesthetic form and political content. Perhaps ironically, given the Leftist turn towards proletarian realism and more agitational theater that took place in the late 1920s, one of the earliest articles devoted to the details of stage lighting was published in the League of Left-wing Dramatists organ, *Xiandai xiju* 《现代戏剧》 (Modern Drama), in 1929.⁵⁶ Edited by spoken drama theorist and director Ma Yanxiang 馬彥祥 (1907-1988) and lasting for only two issues in May-June of that year, *Modern Drama* featured essays by several prominent Chinese actors and theater reformers, including Ma himself, future *Play* editor Yuan Muzhi, Chen Dabei 陳大悲 (1887-1944), and Hong Shen 洪深 (1894-1955). While the contents of the journal are

⁵⁵ Ouyang Yuqian, “*Nuhouba, Zhongguo! zai Guangdong shangyan ji*,” 52. Reprinted in Qiu Kunliang, 634.

⁵⁶ *Xiandai xiju* is digitized and searchable in the Shanghai Library Chinese Periodicals Full-text Database (Quanguo baokan suoyin Minguo shiqi qikan quanwen shujuku 全國報刊索引民國時期期刊全文數據庫); for more information on the periodical, see: Li Xiao, *Shanghai huaju zhi*, 330.

eclectic overall, the second issue focused on the practical and technical sides of the theater: it contained several photographs of productions by and translated articles on Austrian-born American theater director Max Reinhardt (1873-1943, transliterated as Laiyinhate 萊因哈特), as well as an article on stage lighting under Ma's pseudonym of Ni Yi 尼一.⁵⁷ Entitled "Wutai dengguang lüetan 舞台燈光略談" (A brief discussion of stage lighting), Ma's article includes no diagrams, but covers the basics of stage lighting history, theory, and application. For instance, he introduces four principles of lighting usage that go on to become common tenets in later lighting handbooks:

1. to illuminate the stage and actors (照見舞台和演員)
2. to suggest the degree of natural light in order to express time, season, and weather (暗示出自然的光度以表明時間，季候和天氣)
3. to expand the value of color, add light and shadow, as well as to harmonize the setting (擴大顏色之價值，增加光和影，以調和劇景)
4. to bring out the meaning and psychology of the script, as well as to supplement the acting (顯示劇中的意義和劇中的心理，以輔助演作)⁵⁸

Ma cites as his source for these basic tenets an English-language text called "Modern Theater" by one "Irving Pickel," likely referring to Irving Pichel's *Modern Theaters* (1926) volume on theater architecture, and includes an additional citation of "The Book of Play Production by Smith" at the end of his article, perhaps referencing Milton Myers Smith's *The Book of Play Production for Little Theaters, Schools, and Colleges* (1926).⁵⁹ Through the combination of articles on Reinhardt, theory, and references to foreign sources, Ma's journal made a clear

⁵⁷ The primary article included is entitled "Laiyinhate yan zhong zhi juyuan" 萊因哈特眼中之劇院 (The Theater in Max Reinhardt's Eyes), with authorship attributed to Reinhardt himself and translation to one "R.D." No source text is mentioned. Max Reinhardt, "Laiyinhate yan zhong zhi juyuan 萊因哈特眼中之劇院 (The Theater in Max Reinhardt's Eyes)," *Xiandai xiju* 《現代戲劇》 2, no. 2 (1929): 1-5.

⁵⁸ Ni yi 尼一, "Wutai dengguang lüetan 舞台燈光略談," *Xiandai xiju* 《現代戲劇》 2, no. 2 (1929): 112.

⁵⁹ Ma's misspelling of Pichel's name leads me to wonder if he may be relaying an aural summary of the text by one of his colleagues who had studied abroad rather than having had access to the physical book.

connection between advances in theater technology and the modernization of the drama—all under a Leftist political umbrella. This seems to suggest a clear connection between a working knowledge of the stage’s more technical aspects and the political efficacy of the theater.

In the above case, the publication of such details for a specialist audience provides evidence of a growing trend in the Chinese theater world. Discussions in this vein in fact had appeared in print in China since the mid-19th century, when traveling officials and students wrote about their experiences seeing foreign theater, and descriptions of fanciful sets in serialized opera performances and variety shows commonly appeared as advertising throughout the 1920s and 1930s.⁶⁰ Surveying newspaper databases and catalogs of Republican era periodicals, we do find sporadic references to Western lighting theorists, as well as theater-specific journals and magazines as early as the 1910s.⁶¹ For example, writing to advocate a non-commercialized “amateur theater” (*aimei de xiju* 愛美的戲劇) in the early 1920s, theater reformer Chen Dabei touches upon details such as theater space, scenic design, lighting, costumes, and management, as well as introducing the work of Western theorists and practitioners like Edward Gordon Craig.

Another series of personal essays published in the *Chenbao fukan* 晨報副刊 (Morning Post Supplement) in 1923-1924 by playwright and theater educator Yu Shangyuan 余上沅 (1897-1970) during his time studying at Carnegie Tech and Columbia University introduces Chinese readers to a number of important American theater directors, actors, playwrights, and

⁶⁰ Li Chang, “Zhongguo jindai huaju wutai meishu piantan,” 268–269.

⁶¹ According to the *Shanghai Spoken Drama Gazetteer*, the first spoken drama-related periodical was *Xinju zazhi* 《新劇雜誌》 which began publication in May 1914. Catherine Vance Yeh has also discussed the rise of entertainment tabloids in Shanghai in the late 1890s-1920s and their influence on theater culture. See *Shanghai huaju zhi*, 328; Catherine Vance Yeh, “A Public Love Affair or a Nasty Game? The Chinese Tabloid Newspaper and the Rise of the Opera Singer as Star,” *European Journal of Asian Studies* 2, no. 1 (2003): 13–51.

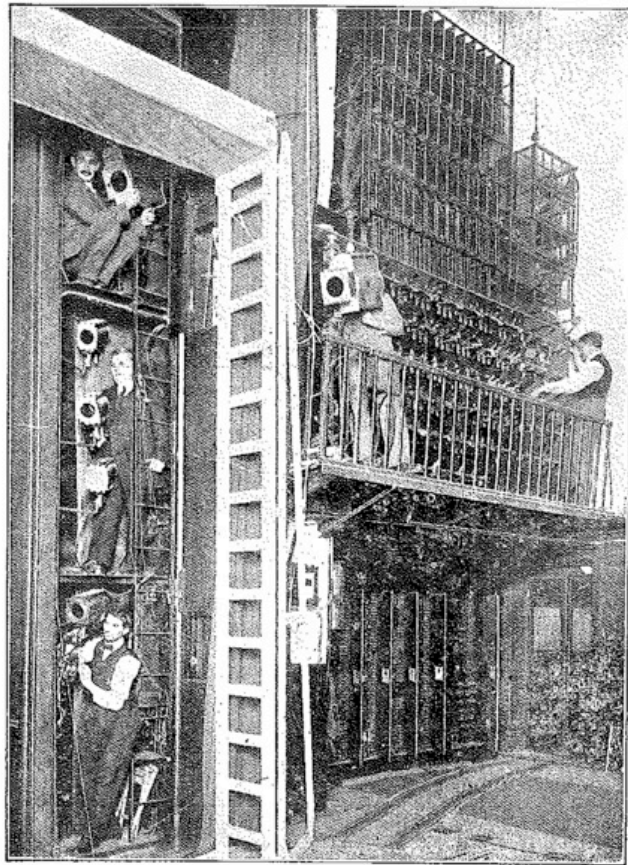

舞臺燈光的工具

Figure 8 Photograph of lighting equipment included in Yu Shangyuan’s *Collected Essays on Drama* (Source: Yu Shangyuan, *Xiju lunji*, 1927)

practices.⁶² His *Xiju lunji* 《戲劇論集》 (Collected Essays on Drama), published in 1927, then reprints several of these earlier pieces, including those on lighting instruments and color.⁶³

[Figure 8] With titles such as “Ershi xiaoshi de Zhijiage” 二十小時的芝加哥 (Twenty Hours of Chicago), his first essays focus on the experiences of leaving his home country for the first time. As he writes, however, the pieces become more polemical and more technical, calling for the establishment of “little theater” (*xiao juchang* 小劇場) in China and providing detailed

⁶² Yu Shangyuan 余上沅, “Qinxian 《芹獻》,” *Chenbao fukan* 《晨報》副刊, November 1923-May 1924. Reprinted in *Xiju lunwen ji* 《戲劇論文集》 (Wuhan: Changjiang wenyi chubanshe, 1986).

⁶³ Yu Shangyuan 余上沅, *Xiju lunji* 《戲劇論集》 (Shanghai: Beixinshuju, 1927).

descriptions of equipment and color theory for stage lighting. In these essays, Yu Shangyuan even goes so far as to advocate the complete replacement of scenery with lighting effects.

However, Yu was a few years ahead of his time, and most of the theater-specific periodicals from the 1910s-early 1920s focus on *xiqu* performers and performances, introducing foreign plays and playwrights, or parsing acting techniques. Then, beginning with Ma Yanxiang's contribution to *Modern Drama*, we may observe a slow but steady increase in the number of technical articles published in theater periodicals. One of the factors propelling this significant shift in content may have been the rapid increase in the number of spoken drama theater troupes that occurred during this same period. As Michel Hockx has demonstrated in the case of literary societies and literary journals, Shanghai in the 1920s-1930s provided a particularly rich nexus for creative exchange and production of print material.⁶⁴ The same could be said for the theater world, when the number of small spoken drama troupes increased in tandem with an influx in writing about the theater. The Theater Society of the Masses (Minzhong xiju she 民眾戲劇社), which published six issues of *Xiju* 《戲劇》 (Drama) in 1921, and Tian Han's Southern Society (Nanguo she 南國社), which published various periodicals beginning in 1924, offer two early examples, and the trend continued into the next two decades.

The many journals associated with professional theater schools, amateur theater troupes, and political drama societies offered readers an amalgam of introductory lessons and more sophisticated theories that were current with avant-garde practices in Europe, the United States, and Russia. Take, for example, two articles in the issue of *Juxue yuekan* 《劇學月刊》 (Theater Studies Monthly) coincidentally published the month before *Roar, China!* opened in Shanghai in

⁶⁴ See Chapter 3 in Hockx, Michel, *Questions of Style: Literary Societies and Literary Journals, 1911-1937* (Leiden: Brill, 2003).

1933. Associated with the Beijing (the Beiping) campus of the Nanjing Opera and Music Academy (Nanjing xiqu yinyue yuan 南京戲曲音樂院), *Theater Studies Monthly* did not typically publish articles on spoken drama, but this particular double issue was christened the “Theater Studies Monthly Spoken Drama Issue” and opened with a full-page photograph of the Roxy Theater in New York.⁶⁵ The photograph, however, does not depict the audience view of the stage, as one might expect. Rather, it is taken from a vantage point center stage that highlights the offstage lighting equipment, and it is followed by a two-page spread that includes close-ups of several lighting units. [Figures 9-10] Beyond these, a sixty-four page article on stage lighting by director Jiao Juyin 焦菊隱 (1905-1975) occupies nearly a full quarter of the magazine’s length, and even editor Cheng Yanqiu’s 程硯秋 (1904-1958) general article on spoken drama directing devoted several sections to a detailed discussion of lighting principles and equipment. In short, the journal issue draws a direct connection between lighting design and spoken drama, which is only further underscored when Cheng Yanqiu writes: “We might say that the dimmer (*bian deng qi* 變燈器) is the soul of lighting, just like lighting is the soul of the performance and the director is the soul of the theater.”⁶⁶ Elevating a specific piece of lighting equipment, the dimmer, to the same level as the actor and the director, Cheng makes a strong argument for the artistic and aesthetic importance of theater technologies.

The dimmer that Cheng mentions, equally significant for its ability to control the level of light and combination of light colors onstage, constituted a major technical challenge for Chinese theater artists. As a comment by Ouyang Shanzun in his article on the subject in *Play* notes, by

⁶⁵ Photo with caption “美國紐約的羅克西(Roxy)劇院之舞台燈光設備 (Stage lighting equipment at the Roxy Theater in New York, USA)” in *Juxue yueka* 《劇學月刊》 2 no. 7-8 (August 1933): npn.

⁶⁶ Cheng Yanqiu 程硯秋, “Huaju daoyan guankui 話劇導演管窺,” transcribed by Liu Shouhe 劉守鶴, *Juxue yuekan* 《劇學月刊》 2, no. 7-8 (1933): 47.

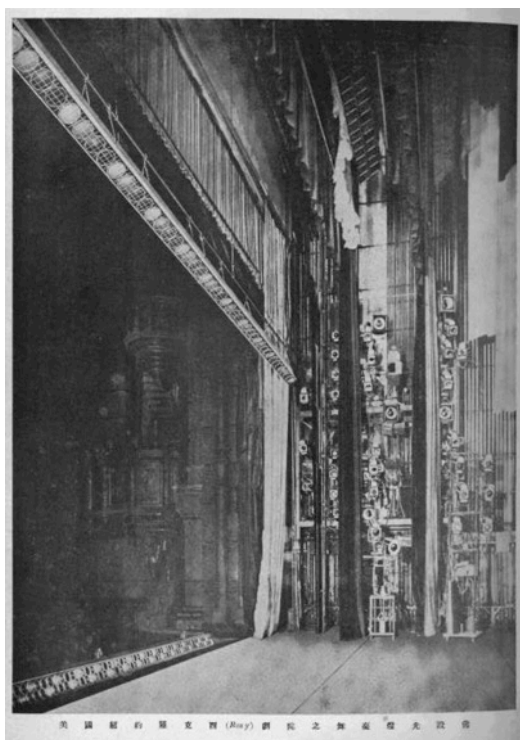

Figure 9 The Roxy Theater, as depicted in *Theater Studies Monthly* (Source: *Juxue yuekan* 2 no. 7-8 [August 1933])

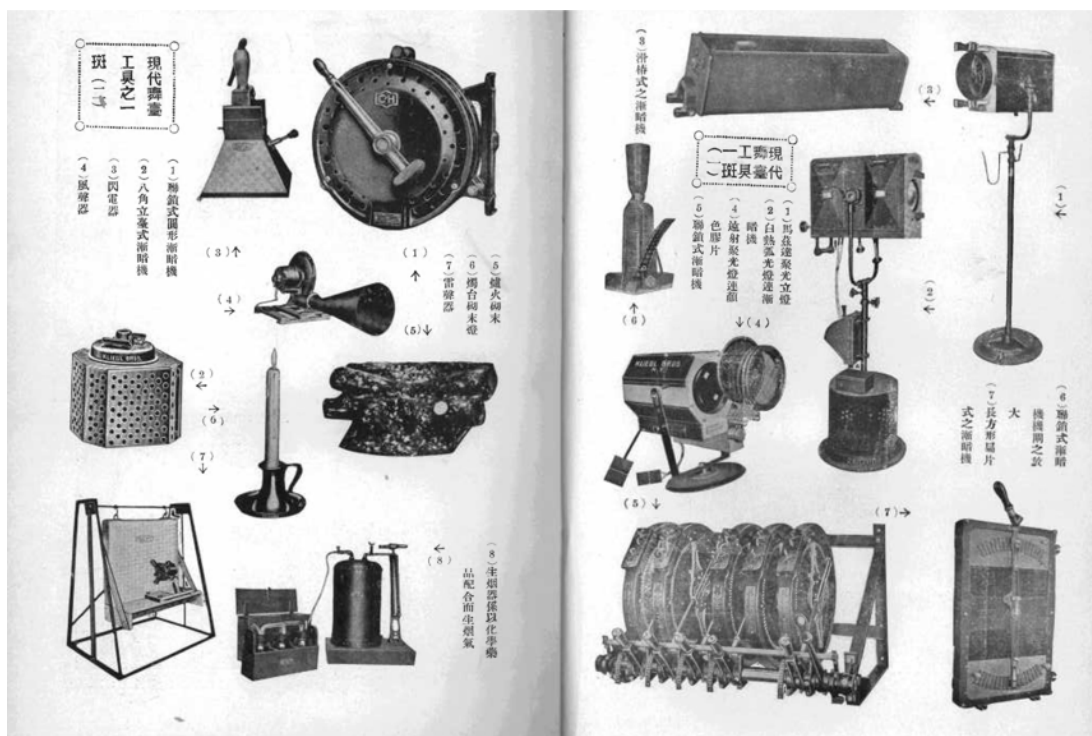

Figure 10 “Tools of the Modern Stage” (*xiandai wutai gongju zhi yiban* 现代舞台工具之一斑) (Source: *Juxue yuekan* 2 no. 7-8 [August 1933])

the 1930s dimmers were already commonly used in movie theaters to lower and raise the lights during film screenings.⁶⁷ However, the frequent publication of descriptions of how to make the simplest form of dimmer, a liquid rheostat (or saltwater) dimmer, in theater periodicals and handbooks throughout the 1930s and 1940s suggests its general absence from many performance venues.⁶⁸ [Figure 11] Like Ouyang Shanzun for *Roar, China!* or Xia Yan 夏衍 (1900-1995) for the 1930 stage adaptation of *Xixian qu zhanshi* 《西線無戰事》 (All is Quiet on the Western Front), designers often had to make their own ad-hoc, rudimentary dimmers.⁶⁹ Yet, despite this difficulty, the work of the dimmer became a central tenet of Chinese theater practice: that the movement of light between different levels of brightness and different colors could be used to convey and control shifts in the atmosphere and emotion of the action unfolding onstage.

Cheng Yanqiu gestures to this principle in his paraphrase of Swiss theater designer and theorist Adolphe Appia's (1862-1928, transliterated as A'biya 阿比亞) concept of "lighting

⁶⁷ Ouyang Shanzun 歐陽山尊, "Dianqi jian: zui jiandan de dimmer de zuofa 電氣間: 最簡單的 dimmer 的作法," *Xi* 《戲》 1, no. 1 (1933): 40-43.

⁶⁸ A liquid dimmer operates by moving two pieces of metal, attached to electric cords, in an ionized solution. When the metal pieces are close or connected, the current is stronger and the attached light brighter; when farther apart, the current is weaker and the light dimmer. In addition to references in the texts by Yu Shangyuan and Jiao Juyin discussed above, see also He Mengfu, *Wutai Zhaoming*; Huang Huang 黃惶, "Dengguang de yanyong 燈光的御用," *Minzu wenyi yuekan* 《民族文藝月刊》 1, no. 3 (1937): 12-14; Wu Renzhi 吳仞之, "Wutai guang 舞台光," *Juchang yishu* 《劇場藝術》, no. 1,3,6 (1939 1938). The image is taken from Xingui 心規 "Tan zhaoming xuwan 談照明續完" *Kangdi xiju* 《抗敵戲劇》 (Resistance Drama) 2, no. 3-4 (1939).

⁶⁹ According to theater scholar Ma Junshan, who argues that the 1930s were a key period in the maturation of scenic design in China, Xia Yan built a saltwater dimmer (*yanshui jiedianqi* 鹽水節電器) for the production of a stage adaptation of *Xixian wu zhanshi* 《西線無戰事》 (All is Quiet on the Western Front) by the Shanghai Art Theater Society (Shanghai yishu jushe 上海藝術劇社) in 1930. Ma Junshan 馬俊山, "Yanju zhiyehua yundong yu huaju wutai yishu de zhengtihua 演劇職業化運動與話劇舞台藝術的整體化," *Wenyi zhengming* 《文藝爭鳴》, no. 4 (2004): 45-52.

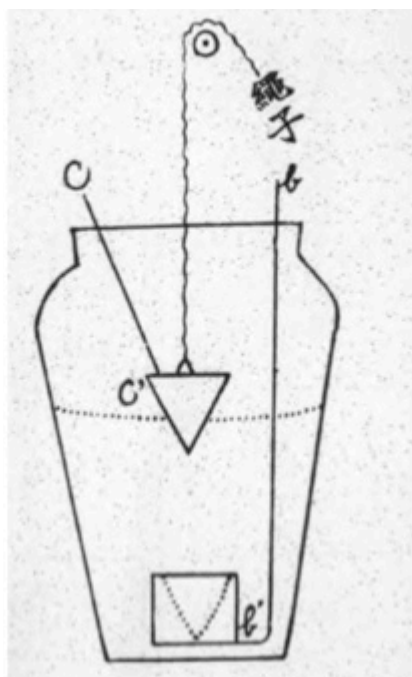

Figure 11 Liquid dimmer, as depicted in *Resistance Drama* (Source: Xingui “Tan zhaoming xuwan” *Kangdi xiju* 2, no. 3-4 [1939])

as the soul of the theater” (xiju de linghun 光為戲劇的靈魂).⁷⁰ Writing in the same issue of *Theater Studies Monthly*, Jiao Juyin—who would go on to become one of the preeminent spoken drama directors of the PRC—expounds at more length upon the importance of lighting. Light, Jiao states, is “one of the greatest elements governing human emotions” and, when employed in

⁷⁰ Appia, who in Chinese sources is often discussed in tandem with that of Edward Gordon Craig (transliterated as Gedeng Kelei 戈登克雷), was introduced to Chinese readers of the *Shenbao* as early as 1926 and, as noted above, frequently appeared in articles related to technical theater and lighting (Gu Jianchen 谷劍塵, “Xiao wutai geming xin diyi sheng 笑舞台革新第一聲” *Shenbao* 《申報》 1926.04.17). The famous phrase is repeated variously as “After all, light has been called the life of the stage 燈光竟被成為舞台的生命” (Xiang Peiliang 向培良, *Wutai secail xue* 《舞台色彩學》, 52); “‘Light’ is the energy within the life of the ‘scenery’ ‘光’是‘景’的生命中的活力” (Wu Renzhi, “Wutai guang,” 15-16); “Light is the life of the modern stage 光是進世舞台的生命” (Shi 時 (Ai Junjie 艾俊階) “Zai tan wutai zhaoming 再談舞台照明” *Sanliujiu huabao* 《三六九畫報》 68 (1936): 12); “So, some say that the stage’s life is the lighting 所以有人說：舞台底生命是燈光” (Li Puyuan 李朴園 *Xiju jifa jianghua* 《戲劇技法講話》 Shanghai: Zhengzhong shuju, 1936/1943). For a brief overview of Appia’s lighting theory, see Beacham, Richard C., “Introduction,” in *Adolphe Appia: Texts on Theatre* (New York: Routledge, 1993), 5.

the theater, colors the emotions of the characters onstage and those of the audience.⁷¹ The property of light also proves the close interrelation of science and the arts in which the technique is scientific but the effects (and affects) produced qualify as art. Jiao's inclusion of a list of specific lighting colors that links each color to a list of meanings and emotions further suggests that, with a careful (scientific, perhaps) calibration, a director or lighting designer might not only invoke, but also provoke certain emotions in his or her audience. Jiao is, however, careful to qualify his theory with the caveat that audience members will not necessarily have a unified response to use of a given lighting effect on stage; symbolic associations are culturally contingent and affective response highly subjective.

For other theater artists and reformers, this position did not take the possibilities of lighting nearly far enough. Writing a few years after Jiao Juyin, theater theorist Xiang Peiliang 向培良 (1905-1959) likewise paraphrases the notion that lighting is the soul of the stage, but extends it to argue that colored light, in particular, could directly control the emotions (and therefore color was the true life of the theater).⁷² Putting it even more bluntly, director Wu Renzhi 吳仞之 (b. 1902) would later echo this sentiment: "Using light to manipulate the emotions is one of the most important applications of stage lighting."⁷³ An article by Zhang Geng 張庚 (1911-2003), a Party member and later vice-president of the Central Drama Academy, reveals why this particular theory of lighting design would become prevalent by the end of the decade: correctly employed, colored lighting could be used to "build the audience's

⁷¹ Jiao Juyin 焦菊隱, "Wutai deng chujiang 舞台燈初講," *Juxue yuekan* 《劇學月刊》 2, no. 7-8 (August 1933): 5-6. Reprinted in *Jiao Juyin wenji* 《焦菊隱文集》 (Beijing: Wenhua yishu chubanshe, 1988), 66.

⁷² Xiang Peiliang 向培良, *Wutai secai xue* 《舞台色彩學》 (Shanghai: Shangwu yinshua guan, 1935), 62.

⁷³ Wu Renzhi, "Wutai guang," 11.

revolutionary feeling.”⁷⁴ It was then only a small step from provocation of the senses and emotions to the agitation of the people themselves, from *gandong* 感動 to *dadong* 打動. Referencing Meyerhold, Zhang Geng suggests the use of red light at the climax of a play to build spectator emotion to a fevered pitch. Zhang Geng’s color choice may seem obvious and uninspired, but it is not insignificant. What these various technical writings demonstrate is that, in the years surrounding the Shanghai Theater Society production of *Roar, China!*, Chinese theater artists were beginning to look to technical elements of the theater as a way to inspire passion and action in their audiences via a mixture of physiological and affective response.

At the same time, however, this was not purely a project of audience manipulation. Alongside the many professional theater publications of the 1930s, another spate of publishing arose that, like *Play*, targeted audience members themselves. For instance, two important compendia covering the fundamentals of theater practice, from playwriting to troupe management to technical theater, appeared in 1935-1936. First, the National Professional College of Theater, or National Theater College (Guoli xiju zuanke xuexiao 國立戲劇專科學校) included in 1935 (in Nanjing) put out a series of tutorials in the mid-late 1930s.⁷⁵ Few of these are extant today, but bibliographies list titles including a book on stage sets, *Wutai sheji tiyao* 《舞台設計提要》 (Highlights of Scenic Design) by the then-retired Yu Shangyuan.⁷⁶ More

⁷⁴ Zhang Geng 張庚, “Wei guanzhong de xiju jianghua: shiyi, wutai dengguang he xiaoguo 為觀眾的戲劇講話：十一 舞台燈光和效果,” *Shenghuo zhishi* 《生活知識》 1, no. 12 (1936): 607.

⁷⁵ The guidelines for the publishing committee do not specifically reference this set of texts, but bibliographic sources do, *Guoli xiju xuexuan yilan* 《國立戲劇學校一覽》 (Nanjing: Guoli xiju xueyuan, 1935).

⁷⁶ The title of the series is National Professional College of Theater Theater Tutorial Series (Guoli xiju zuanke xuexiao xiju fudao xiao congshu 國立戲劇專科學校戲劇輔導小叢書). A microfilm copy of the volume by Yu Shangyuan is held by the National Library in Beijing, but inaccessible to the public. Referenced in 北京图书馆, *Minguo shiqi zong shumu, 1911-1949 (Wenhua, kexue, yishu)* 《民國時期總書目, 1911-1949》, vol. 15 (文化, 科學, 藝術) (Beijing: Shumu wenxian chubanshe, 1994).

titles survive from a second set, the *Xiju xiao congshu* 戲劇小叢書 (Theater Series), which was edited by Xiang Peiliang and Xu Gongmei 許公美 and published by Shanghai Commercial Press (Shangwu yinshuaguan 商務印刷館) in 1935-1936.

The latter series included no fewer than twenty slim volumes, and topics ranged from broad overviews on drama, opera, and Chinese theater history to more specialized texts on acting, directing, and individual areas of technical theater. Zhang Geng opened the series with the sweeping *Xiju gailun* 《戲劇概論》 (An Overview of the Drama), designer He Mengfu 賀孟斧 (1911-1945) contributed a volume on *Wutai zhaoming* 《舞台照明》 (Stage Lighting), and Xiang Peiliang delved into the realm of theory with his *Wutai secai xue* 《舞台色彩學》 (Color Studies for the Stage). At first glance, these texts seem to continue in the vein of earlier technical articles in theater society periodicals, which largely targeted current and aspiring theater practitioners. Indeed, many of the more advanced theories about lighting, color, and affect are articulated on the pages of these volumes. However, despite these characteristics, their palatable size and low average price of two *jiao* per book suggest a mass market beyond the relatively limited sphere of active theater practitioners. A *Shenbao* advertisement even claims that their clarity would “make professional researchers think them not ordinary or superficial, and make beginners not find them too difficult”—echoing the inclusive sentiment adopted by *Play* in the passage referenced at the top of this chapter.⁷⁷ Offering lay readers and amateurs a route to expertise, the very accessibility of these volumes makes an argument for the general importance of specialized knowledge.

⁷⁷ Moreover, the authors and editors of these volumes were largely Beijing-based theater educators and theorists, but the series was published by the Shanghai Commercial Press and therefore would have been widely distributed. *Xiju xiao congshu* advertisement, *Shenbao* 《申報》 1935.10.16

On the one hand, these volumes may be seen as participating in a broader project to construct “modern,” “scientific” know-how, which Leo Ou-fan Lee has termed the “the business of enlightenment” in his discussion of the Shanghai Commercial Press “repositories” of general knowledge published in the 1920s-1930s.⁷⁸ Lee frames the publication of such sets as part of a political project: “the introduction of new knowledge was animated by a desire to keep China abreast of what was going on around it while at the same time the press sought to support the effort of nation building by providing intellectual resources for both the state and its ‘people.’”⁷⁹ Like the larger sets of repositories (*wenku* 文庫) published from 1929-1934, the theater series (*congshu* 叢書) may be seen as involved in nation-building via attempts to establish history and practices for a national theater. There was even a volume entitled *Xiju ABC* 《戲劇 ABC》 (ABC’s of Theater) that included simplified discussions of sets, lighting, and other technical elements and belonged to one of these more general series, alongside books on world literature, art, religion, law, science, and government, released by the World Publishing House (Shijie shuju 世界書局) in 1931.⁸⁰ The series seems designed to cultivate a knowledgeable, modern audience for that theater. In offering introductions that are at once specialized and easily accessible, both legitimated through their scientific, rational organization and canonized through encyclopedic framing, it recasts a previously opaque artistic practice as something that could—and should—be systematized, disseminated, and understood by the general public. Similar to the way in which

⁷⁸ Lee Leo, *Shanghai Modern: The Flowering of a New Urban Culture in China, 1930-1945* (Cambridge, MA: Harvard University Press, 1999), 55.

⁷⁹ *Ibid.*, 62–63.

⁸⁰ In the realm of theater, the series also included a volume on opera and another on one-act plays. Chen Dabeī 陳大悲, *Xiju ABC* 《戲劇 ABC》 (Shanghai: Shijie shuju, 1931).



Figure 12 “The Technologization of the Stage” in *Small World* (Source: *Xiao shijie* 50 [1934]: 12)

May Fourth interest in Ibsen linked a realist aesthetic project to social reform, these volumes connect a technical epistemological project with national strengthening.

A similar impulse can be seen in articles in popular periodicals, which introduced readers to modern theater through vivid photographs and even more basic introductions. A bi-monthly pictorial called *Xia shijie* 《小世界》 (Small World), for example, carried a full page spread illustrating the “technologization” of the stage (*wutai jixie hua* 舞台機械化) in one of the its 1934 issues.⁸¹ [Figure 12] Zhang Geng’s comments on Meyerhold and inspiring revolutionary feeling through lighting were in fact published in a set of twelve short articles in *Shenghuo zhishi* 《生活知識》 (Everyday Knowledge) entitled “Wei guanzhong de xiju jianghua” 為觀眾的戲劇

⁸¹ “Wutai jixiehua 舞台機械化,” *Xiaoshijie: tuhua banyuekan* 《小世界:图画半月刊》 50 (1934): 12. 民国时期期刊全文数据库 database.

講話 (Lectures on Theater for Audience Members), which was serialized in 1935-1936. In addition to referencing Meyerhold, the “lecture” on lighting included a discussion of Appia’s lighting theory and the importance of lighting to conveying the temporal dimension of the theater.⁸² However, in contrast with the accessible yet detailed compendia, these glossy photos of lighting arrays and more superficial references to foreign theories toe a finer line between knowledge transfer and knowledge performance. Here, the specter of the spectacle arises, threatening to dazzle readers with impressive displays rather than truly educate them. This tension parallels the problematic association of onstage technologies with bourgeois entertainment, discussed above, and would only heighten as theater became increasingly politicized in the subsequent decades.

Latent conflicts notwithstanding, if we extend the reading of *Play* as a guide for a specific production to these compendia volumes and popular articles that were published around the same time, we begin to see a broader project of training audiences to understand and appreciate the technical dimensions of the modern theaters. This was not a vanity project on the part of increasingly specialized theater practitioners, but rather an essential part of ensuring that audiences would understand the political critiques that were increasingly embedded in the technical elements of productions. After all, it was during this period that modern classics like Cao Yu’s *Thunderstorm* and *Sunrise* would achieve new heights as both dramatic literature and well-staged plays.⁸³ These new works exceeded *Roar, China!* in bridging the gap between form

⁸² Zhang Geng, “Wei guanzhong de xiju jianghua,” 606.

⁸³ Phenomenon such as maturation of scenic design that would take place in the mid-1930s have previously been attributed to an increased availability of better theater spaces and a “performance professionalization movement” (*yanju zhiyehua yundong* 演劇職業化運動). Theater scholar Ma Junshan argues for example, that local Shanghai spoken drama troupes began to perform in larger, better-equipped theaters in 1935 and that the necessity of working with these spaces led to significant advances in stage design and technical theater. Ma Junshan, “Yanju zhiyehua yundong yu huaju wutai yishu de zhengtihua,” 45–52.

and content, employing central metaphors—a thunderstorm, a sunrise—whose realization onstage required even more sophisticated manipulation of lighting, sound, and special effects. While on the one hand practical, specialized publications were necessary to enable theater artists to produce work in this mode, on the other, simple and even superficial introductions to theater technology were equally essential to train a tech-savvy audience that could appreciate their critique.

Scripting Technology as Dramaturgical Mode

In the case of *Roar, China!*, the intervention of the director and designers transformed an already political play into a critique of foreign imperialism operating on a technical level. Their technical critique is uniquely well documented, especially compared with the many other productions from this period that survive only in sparse photographs, published reviews, and later memoirs. Proof of the significance and pervasiveness of this ephemeral mode of critique—and therefore, the importance of having an audience sensitive to this mode—instead can be found in an unexpected place: play scripts.

At the time *Roar, China!* premiered, *huaju* was still a young genre, and dramaturgical practice was still in flux. Few early scripts, for example, included precise descriptions of their technical elements. Randy Barbara Kaplan has argued that Tian Han's plays written during the 1920s relatively unique in their attention to realistic mise-en-scene, including sound and lighting: "His use of artificial indoor light represents a significant breakthrough in Chinese theater history: the source of illumination is visible and realistic for the period and locale being represented."⁸⁴ Kaplan further credits Tian with a "sensitivity to the potential emotional effects of lighting in

⁸⁴ Randy Barbara Kaplan, "Planting the Seeds of Theatrical Realism in China: Tian Han's Contributions to Modern Chinese Drama, 1920-1929," *World Literature Today* 62, no. 1 (Winter 1988): 60.

performance” that resonates with the lighting theories expounded in technical articles and handbooks.

If Tian Han helped to inaugurate a shift is to a tighter interweaving of technical detail and narrative of the play text, it would be renowned playwright Cao Yu who would significantly advance this technique. The trilogy of plays written by Cao Yu in the mid-1930s—*Thunderstorm* (1934), *Sunrise* (1936), and *Yuanye* 《原野》 (Wilderness, 1937)—all feature detailed, almost novelistic, stage directions that have been heralded as a gold standard for dramatic realism. As scenic designer and scholar Li Chang 李暢 writes of Cao Yu: “In terms of scenographic art, the playwright gives an exhaustive description; regardless of whether the sets, lighting, props, costumes, or the atmosphere of the period, it is as if Cao Yu is writing a scenographic textbook, and through this educates directors and designers, leading them towards realism.”⁸⁵ However, Cao Yu’s engagement with theater technology goes beyond atmospheric control. In both *Thunderstorm* and *Sunrise*, the playwright crafts key scenes that, like the production of *Roar, China!*, depend on technically difficult visual and aural effects for their theatrical realization. These scenes, and their technical effects, are in turn essential to propelling the play’s action forward. Without lighting and sound cues, such scenes quite literally cannot go on.

In the case of *Thunderstorm*, it is entirely unsurprising that lighting and sound feature prominently in a play whose title invokes bolts of lightning and crashes of thunder. Similarly unsubtle is the metaphor of the building and breaking storm that drives Cao Yu’s tale of two families in (then) present-day China, one wealthy and well educated, and the other employed in their service. The main plot involves a love affair between the children of the two families,

⁸⁵ Original text: “在舞台美術方面，劇作家有詳盡的描寫，不論在布景，燈光，道具，服裝以及時代氣氛方面，曹禺都等於在劇本中寫了一部布景教科書，並通過它教育了導演和設計者，使他們走向現實注意。” Li Chang, “Zhongguo jindai huaju wutai meishu pianan,” 282.

complicated by jealousy, incest, illegitimate pregnancy, rebellion against traditional kinship structures, an actual workers' revolt and socialist revolution brewing in the background. When *Thunderstorm* opens, the elder son of the wealthy family, Zhou Ping 周萍 finds himself in a difficult situation: he has had an affair with his stepmother, but now is in love anew, this time with the family's vivacious young maid, Sifeng 四鳳. His younger brother Zhou Chong 周冲 also fancies himself, rather innocently, in love with Sifeng. Ping and Sifeng's plans to be together are further complicated, however, by the revelation that Sifeng is actually Ping's half-sister, from a long-ago love affair between Ping's father and Sifeng's mother, who now have not seen each other in twenty years. As the truth is melodramatically revealed, these tangled relationships unravel to tragic ends, and a subplot of brewing trouble at the Zhou family mine ensures certain doom for the old Chinese gentry family's way of life.

The play's dark portrayal of "feudal" society and patriarchal oppression made it resonate with contemporary desires for sweeping national reform. Then and since, it has generally been interpreted as in line with the enlightenment program of May Fourth reformers and the New Culture Movement, especially its critical attitude toward traditional Chinese culture and values. At the same time, it has also been noted that Cao Yu drew heavily on the Western canon—most clearly, Euripides' *Hippolytus*, but scholars have argued that the play was directly influenced by—or at least is in dialogue with—a long line of works of tragic incest, from *Hippolytus* to Racine's *Phedre* to Eugene O'Neill's *Desire Under the Elms*. There are also clear points of connection to Ibsen's *A Doll's House* and *Ghosts*, as well as to Russian playwright Alexander Ostrovsky's *The Storm*.⁸⁶

⁸⁶ The literary studies relating Cao Yu's work to the Western canon are too many to list here. See for example: Joseph S. M. Lau, *Ts'ao Yü, the Reluctant Disciple of Chekhov and O'Neill a Study in Literary Influence* (Hong Kong, China: Hong Kong University Press, 1970).

On the level of stage technology, the burden of creating the proper atmosphere for this melodramatic web of intertextualities falls on lighting and sound effects. Cao Yu's carefully wrought stage directions suggest that a central element of the play's performance was the realistically replication of the visual, aural, and affective dimensions of a thunderstorm. For example, if we take one iconic scene between the two young lovers, from the third act:

(A crescendo of thunder, a deafening crash)

Sifeng (*quietly*): Oh, Mom! (*Running into Ping's arms.*) I'm frightened!

(The thunder roars and rain pours down in torrents. The stage darkens even more, and in the blackout can be heard:

Sifeng: Hold me. I'm afraid.

(The stage goes completely dark for a moment, with only the flickering light of the lamp on the table and eerie blue flashes of lightning outside the window. Lu Dahai's voice is heard outside shouting to be let in. Lu Dahai is heard entering the house. The lights gradually come on again. Zhou Ping is sitting on the chair, while Lu Sifeng stands close by. The bed sheets are somewhat ruffled.)

(雷聲大作。一聲暴雷。)

四：(低聲)哦，媽。(跑道萍懷裏)我怕！

(雷聲轟轟，大雨下。舞台更暗，黑暗中聽見。)

四：你抱著我。我怕。

(舞台黑暗一時，只露著圓桌的洋燈，和窗外的閃電藍森森地。聽見屋外大海叫門的聲音，大海進門的聲音。舞台漸明，萍坐在圓椅上，四在旁立，床上微亂)⁸⁷

Here, the stage directions guide the reader to imagine eerie flashes of light, torrents of rain, the shivers of fear provoked by spectacular summer storms. Onstage, the details that enliven the play as literary text burden designers and technicians with their complexity and precision. Such a literary storm becomes, in performance (especially in China in the 1930s), a significant technical difficulty.

⁸⁷ My translation. Cao Yu 曹禺, "Leiyu 雷雨," *Wenxue jikan* 《文學季刊》 1, no. 3 (1934): 222.

Successful realization of the stage directions is rendered all the more important by the fact that the playwright uses the storm not just to set the scene, but also to drive it forward. Indeed, Cao Yu invested the storm with so much agency that it functioned, as he himself remarked, as an additional character onstage:

There was originally a ninth character in *Thunderstorm*, who was in fact the most important, but I didn't write him in—a good fellow called 'thunderstorm.' He is nearly always onstage, and manipulates the other eight [characters like] puppets...

雷雨》裏原有第九個角色，而且是最重要的，我沒有寫進去，那是就稱為‘雷雨’一名好漢。他疾呼總是在場，他手下操縱其餘八個傀儡。⁸⁸

The thunderstorm is envisioned here as both god and ghost, a shadow character immaterially present onstage at all time and invested with supernatural control over its characters. In the above scene, we see this is the crescendo of thunder and deafening crash—on stage, two sound effects—that compel Sifeng to throw herself into her lover's arms. This moment proves crucial to the development of the play's plot. Prior to this scene, Sifeng has promised her mother that she would break off her relationship with Zhou Ping, but in a moment of fright, provoked by the thunderstorm, she returns to him. The action then accelerates: Sifeng's brother and mother discover the two together, which prompts Sifeng to run off into the storm. In Act 4, the entire cast of characters searches for her and find themselves at the Zhou family manor, where our playwright writes himself into a corner by revealing that Ping is Sifeng's half-brother...and that she is pregnant by him. He then turns to a power line, downed in the storm, as a modern-day *deus ex machina* to suddenly and tragically resolve his plot—Sifeng, distraught by the news, runs offstage, collides with the wire, and is electrocuted.

⁸⁸ Cao Yu 曹禺, "Richu ba 《日出》跋," in *Cao Yu quanji* 《曹禺全集》 (Shijiazhuang: Huashan wenyi chubanshe, 1996), 385-6.

A similar predilection for technical difficulty can be found in Cao Yu's second play, *Sunrise*, which he wrote in 1936. As is the case in *Thunderstorm*, *Sunrise* features frequent paragraph-long descriptions of the mise-en-scene.⁸⁹ These stage directions often privilege the textures of sets and costumes, but in the final act, which is set in the final moments before dawn, they shift to emphasizing lighting and sound. In fact, the act as a whole can be read as a delicate choreography of lighting: as the sun gradually rises outside of the hotel room window, the characters open and close the curtains multiple times, turn the interior lights on and off. The room alternately brightens and darkens as the protagonist Chen Bailu 陳白露's mood vacillates, once again demonstrating the pervasiveness of the idea that lighting shifts animated the emotional core of the theater. When Bailu, who is deeply in debt and unable to support her bourgeois lifestyle, downs a handful of sleeping pills, the sun rises slowly outside her window and laborers begin to chant as they begin their day's work on a nearby building. In the final moments of the play, the room gradually dims, while the light outside Bailu's window brightens—a clear indication that the lights were dimming on a bourgeois and corrupt way of life, and rising on the new day dawning beyond. The rising sun and proletarian soundscape herald the dawning of a new era for China, one in which the superficial, parasitic middle and upper classes give way to the reign of the worker.

If in *Thunderstorm* the lighting and sound effects propel the plot forward, in *Sunrise*, they become essential to communicating the underlying political message of the play. Cao Yu was not so strident a Leftist as many of the theater artists who had worked on *Roar, China!*, but the message at the end of *Sunrise* is unambiguous. Moreover, like the blackout quick changes in *Roar, China!*, the lighting and sound choreography scripted into Cao Yu's plays relied on stage

⁸⁹ Cao Yu 曹禺, *Richu* 《日出》 (Shanghai: Wenhua shenghuo chubanshe, 1937), 241–242.

technology that, while basic today, was challenging and even dangerous for theater artists at the time. As discussed above, professional theatrical lighting equipment was relatively rare and expensive. The gradual brightening of sunlight described in the final act of *Sunrise* likely also required use of a saltwater dimmer—in its crudest form, an actual vat of electrified, ionized water sitting backstage.⁹⁰

A thunderstorm, too, could prove hazardous. If we look to technical articles published in 1934, the same year *Thunderstorm* was written, we find descriptions of how to create “the sound of thunder” (*leisheng* 雷聲), “a flash of light” (*shanguang* 閃光), and “the sound of rain” (*yusheng* 雨聲)—precisely the components needed to create the effect of a proper thunderstorm onstage. Thunder could be created by shaking a sheet of metal or with a soft drumroll; rain by rolling dry beans around a wooden box. A flash of light however, is suggested as follows:

Creating a flash of light requires collaborating with the lighting department. The method is to take two electrical wires, and on each end affix a metal shaft. Collide the two metal shafts together, and it will produce a flash.

閃光的製造要與燈光部合作,造法是用兩根電線, 在電線的頭上各裝置金屬的桿子, 把這兩個桿子相撞, 就會發出閃光來。⁹¹

The fact that technicians may have risked real execution while producing lighting effects for *Thunderstorm* was painfully apropos, given the plot twist at the end of the play.⁹²

⁹⁰ See Note 68.

⁹¹ Wang Ling 王鈴, “Wutai xiaoguo de zhifa 舞台效果的製法,” *Xiandai yanju* 《現代演劇》 1, no. 1 (1934): 31–32. 民国时期期刊全文数据库 database.

⁹² This was not the only way to create flashes of light onstage. Later articles suggest a visual effect more specific to lightning (*shandian* 閃電) could be created by cutting the shape of a bolt of lightening into a wooden box, painting the box black, and installing a light bulb inside the box. When illuminated briefly, the bolt would then appear to flash. Huang Cun 黃村, “Wutai xiaoguo san (lei, dian) 舞台效果三 (雷, 電),” *Zongyi* 《綜藝》, 1948, 5. 民国时期期刊全文数据库 database.

One might imagine that the dangers of staging would deter playwrights from attempting overly adventurous effects. Cao Yu, however, proves that this was far from the case. At the beginning of his career, he claimed not to write for the stage, but could not help but react to the inevitable productions of his work. In the same essay referenced above, which was written during the composition of *Sunrise*, he complains:

I've seen several productions of *Thunderstorm*, and I always feel that the stage is very lonely. There are only a few people jumping around, with some life missing amongst them. I guess this is probably because that good man 'thunderstorm' never takes the stage, and the people performing have unwittingly left him out...

我看幾次《雷雨》的演出，我總覺得台上很寂寞的，只有幾個人跳進跳出，中間缺少了一點生命，我想大概因為那叫做‘雷雨’的好漢沒有出場，演出的人們無心中也把他漏掉。⁹³

Cao Yu does not reference the technical effects of the thunderstorm specifically and continues to anthropomorphize the thunderstorm. Yet, around the same time he wrote this essay, he also made significant revisions to the text of *Thunderstorm*. These revisions did not involve the addition of a new character to the story—no *jingju*-like manifestations of the Goddess of Lightning (*Dianmu* 電母) or God of Thunder (*Leigong* 雷公) take the stage. Rather, he increased the specificity of the stage directions related to the storm.

Take, for example, the scene quoted at length above. If we look at its later version, published in 1936, we find the stage directions, already evocative in their original, significantly augmented:

(Against the background of a crescendo of thunder there is a deafening crash overhead.)

Sifeng *(in a subdued voice)*: Oh, Mom! *(Then, taking refuge in Zhou Ping's arms)* I'm frightened.

⁹³ Original quote: “《雷雨》裏原有第九個角色，而且是最重要的，我沒有寫進去，那是就稱為‘雷雨’一名好漢...而我總不能明顯地添上這個人，於是導演們也仿佛忘掉他。我看幾次《雷雨》的演出，我總覺得台上很寂寞的，只有幾個人跳進跳出，中間缺少了一點生命，我想大概因為那叫做‘雷雨’的好漢沒有出場，演出的人們無心中也把他漏掉...” Cao Yu, “*Richu ba*,” 385-6.

(Runs to a corner to hide. As the thunder roars and the rain pours down in torrents, the lights are gradually dimmed. A gust of wind blows open the window. It is pitch-dark outside. A sudden blue flash of lightning lights up an eerie white face at the window. It is Zhou Fanyi's. She looks like a corpse as she stands there, heedless of the rain that pelts her disheveled hair, tears streaking down the corners of her eyes as she gazes at the couple in each other's arms. The lightning stops for a moment. The sky is pitch-dark again. A new flash of lightning shows her reaching her hand inside and pulling the window toward her, then fastening it on the outside. As the thunder crashes and roars louder than ever, the stage is plunged into complete darkness. Only Lu Sifeng's low voice can be heard.)

Sifeng (*in a low voice*): Hold me tight. I'm afraid.

(雷聲大作，一聲暴雷。)

四：(低聲) 哦，媽。(跑到萍懷裏) 我怕！(躲在角落裏。)

(雷聲轟轟，大雨下，舞台漸暗。一陣風吹開窗戶，外面黑黝黝的。忽然一片藍森森的閃電，照見了繁漪的慘白發死青的臉露在窗台上面。她像個死屍，任著一條一條的雨水向散亂的頭髮上淋。她痙攣地不出聲地苦笑，淚水流到眼角下，望著裏面只顧擁抱的人們。閃電止了，窗外又是黑漆漆的。再閃時，見她伸進手，拉著窗扇，慢慢地由外面關上。雷更隆隆地聲著，屋子整個黑下來。黑暗裏，只聽見四鳳低聲說話。

四：(低聲) 你抱緊我，我怕極了。⁹⁴

Cao Yu does two things in this revision: first, he adds more clearly the voyeurism of Fanyi 繁漪—the stepmother—outside the window. This is implied in the first published version but not very explicit. Second, he increases the number of special effects that have to happen in this scene. Whereas before we had general storming, here we have specific flashes of light at specific moments that are necessary to illuminate the scene. The flashes of light allow Fanyi to see what's going on with Sifeng and Ping. They also allow us, the audience members, to see Fanyi and recognize her role in the unfolding events. And just as readers now better understand the

⁹⁴ This translation is quoted from the *Columbia Anthology of Modern Chinese Drama*, which relies primarily on versions of the play published in 1935-1936. Original text quoted from a 1943 reprint of the 1936 edition of *Thunderstorm*. Cao Yu 曹禺, "Leiyu 《雷雨》," in *Cao Yu xiji ii 《曹禺戲劇集》*, vol. 1 (Beijing: Wenhua shenghuo chubanshe, 1936), Zhongwen jixian 中文集獻 database; "Thunderstorm," in *The Columbia Anthology of Modern Chinese Drama*, ed. Xiaomei Chen, trans. Wang Tso-liang, A.C. Barnes, and Charles Qianzhi Wu (New York: Columbia University Press, 2010), 157-282.

scene from the stage directions, so too will the theatrical success of this scene depend, even more than before, on the technical execution of these moments of illumination. Writing with an awareness of performance, Cao Yu encodes technical detail and technical difficulty, mobilized in the service of his poetics and dramatic action, back into the dramatic text.

Finally, what was true of Cao Yu's work might be extended to the work of many playwrights involved in the 1930s *huaju* "professionalization movement." As the work of Ma Junshan demonstrates, a large number of new plays written during the 1930s-1940s—such as works by Cao Yu, *Shanghai wuyan xia* 《上海屋檐下》 (Under Shanghai Eaves, 1937) by Xia Yan, *Wu Chongqing* 《霧重慶》 (Misty Chongqing, 1940) by Song Zhi 宋之, and *Shengguan tu* 《升官圖》 (How to Get Promoted, 1945) by Chen Baichen 陳白塵, to name just a few—offer realistic, detailed visions of stage space.⁹⁵ Ma Junshan, like Li Chang, is ultimately more concerned with the development in realism and maturation in stage design than in technical details per se, but his work nonetheless supports the theory that playwrights too began to employ theater technology as a dramaturgical strategy.

Conclusion

The 1933 Shanghai Theater Society production of *Roar, China!* stands out as a significant both because of its advances in staging per se and its revolutionary approach to scripting audience attention to technical detail, enabled by the distribution of *Play* alongside performances. The production laid the foundations for the first golden age of *huaju* in China that would follow it in the mid-late 1930s, and was a key catalyst in the broader creation of a new relationship between theater making and spectatorship wherein the message of the play depended

⁹⁵ Ma Junshan, "Yanju zhiyehua yundong yu Zhongguo huaju wutai meishu de chengshou," 48-49.

equally on its narrative content, performance, *and* technical effects. If we look closely at the text and composition process of playwrights from this era, like Cao Yu, we find that they are not only “scenographic textbooks,” but also records of the influence that changing staging technologies had on the composition of dramatic literature.

However, these moves could be intelligible only to an audience that had been primed with foreknowledge of the technical parameters of a particular production or which was more generally knowledgeable about technical theater. The mode of politically engaged theatrical production that developed in 1930s Shanghai thus necessitated the technical training of theater makers and the development of a tech-savvy audience, educated through performance-specific publications, articles in the popular press, and compendia targeted at amateurs and professionals alike. Armed with this knowledge and the weapons of the stage, this audience in turn would—in theory—go forth to stage their own revolutions in the real world.

Chapter 2

Socialist Utopian Special Effects: Monumental Theater Technology and National Imaginary in the Early PRC

In August 1951, nine set designers and technicians set out on year-long tour of Eastern Europe and the Soviet Union. They were members of the China Youth Arts Troupe (Zhongguo qingnian wengongtuan 中國青年文工團), sent to participate in the 3rd World Youth and Students Festival in East Berlin and to stage exhibition performances throughout the Soviet Bloc as propaganda for the newly established PRC. However, that set designers were included in this mission of cultural diplomacy is a curiosity; most of the troupe was comprised of vocalists and musicians, and photographs of the tour suggest that even opera, dance and acrobatics were performed outdoors or on stages with simple backdrops.¹ What need had they for comrades more familiar with, and more interested in, grand painted backdrops, lighting units, and pulley systems?

The designers primary purpose was not, however, to provide technical support for the troupe, but rather to spend time working in and studying from the staff of famous theaters in the cities visited. Upon their return, the designers compiled a record of their experiences and many of the materials that they had collected on the tour into a volume entitled *Juchang yu wutai jishu* 《劇場與舞台技術》 (Theater and Stage Technologies), which includes photographs, diagrams, and detailed descriptions for both stage machinery and set construction techniques, and they

¹ The Festival took place from August 5-19, 1951, and following its conclusion, the troupe toured East Germany, Hungary, Poland, the Soviet Union, Romania, Bulgaria, Czechoslovakia, Austria, and Albania until returning to Beijing a year later, in September 1952. The centerpiece of the tour was a production of *The White-Haired Girl* (Baimao nü 《白毛女》), but performances also included excerpts from Peking Opera, Xinjiang and Tibetan dance, acrobatics, vocal solos and choral pieces, and instrumental performances on pipa and violin, among others. The troupe totaled 222 members, with 19 staff, 51 instrumental musicians, 44 dancers, 7 Peking opera actors, 28 opera performers, 34 vocalists, 30 acrobats, and 9 set designers. Shi Yajuan 石雅娟, ed., *Dang women zaici xiangju: Zhongguo qingnian wengongtuan chufang 9 guo yinian ji* 《當我們再次相聚：中國青年文工團出訪9國一年記》 (Beijing: Wenhua yishu chubanshe, 2004), 487–495.

went on to participate in the design and construction of countless new theater spaces around the country.² Their work propelled a veritable “great leap” in Chinese theater, but one that took place in the realms of physical construction as much as artistic production.

The inclusion of set designers on a quasi-diplomatic mission speaks to the importance of the performing arts, in general, and stage technology in particular in the early years of the PRC. Under the leadership of Chairman Mao, theater artists found themselves in the midst of broad state attempts to create new institutional structures, construct the material infrastructure of a culturally and economically successful nation, and, with the beginning of the Great Leap Forward (*da yuejin* 大躍進) in 1958, to launch “great leaps” in industrial and technical capacities across professions. For the theater, this entailed both the construction of monumental theater spaces, modeled on the Soviet style and bespeaking the power of the state, and the production of new theatrical works, in great numbers and in the service of the “workers, peasants, and soldiers” (*gong nong bing* 工農兵).

Renowned playwright and head of the Chinese Dramatists Association (Zhongguo juzuojia xiehui 中國劇作家協會), Tian Han 田漢, responded to calls for massive output of new theatrical works by pledging to write 10 new plays in the first year of the Great Leap Forward. The first of these plays, *Guan Hanqing* 《關漢卿》 (Guan Hanqing) is a biographical play about the eponymous Yuan dynasty playwright, which depicts his composition of *Injustice to Dou'E* (Dou'E Yuan 《竇娥冤》), also titled *Snow in Midsummer* as a heroic response to evils perpetrated upon the common people by China's Mongolian overlords. A historical work that is, as Rudolph Wagner has argued, easily read as an autobiographical allegory, *Guan Hanqing*

² Li Chang 李暢 et al., *Juchang yu wutai jishu* 《劇場與舞台技術》 (Wuhan: Zhongnan renmin wenxue yishu chubanshe, 1954).

seems out-of-place among the other socialist realist plays produced during this period. This is only more the case if one compares it to the second Great Leap Forward play penned by Tian Han, *Shisan ling shuiku changxiang qu* 《十三陵水庫暢想曲》 (*Fantasia of the Ming Tombs Reservoir*, 1958). Like *Guan Hanqing*, *Fantasia of the Ming Tombs Reservoir* makes artists and performers into characters, but set in the present day and depicting their visit to the site of a dam construction project, it more obviously commemorates and extols the successes of state-sponsored civil engineering projects and mass mobilization. However, the performative rewriting of Chinese theater history in *Guan Hanqing* and the depiction of contemporary efforts in *Fantasia* in fact both participate in a shared impetus to imagine the theater world—past, present, and future—according to ideals of revolutionary heroism, concern for “the people,” collective effort and socialist progress.

In this chapter, I will examine the theatrical imaginary of the young PRC, as articulated in works like *Guan Hanqing* and *Fantasia of the Ming Tombs Reservoir*, against the backdrop of material changes in the architectures and technologies built in an era of rampant societal construction (*shehui jianshe* 社會建設). In the first half of the chapter, I examine how visions of the theater, as both a cultural institution and as physical space, became an important component of state visions for a new China in the early 1950s. Discussing both the ways in which the arts were subjected to rationalized systems of production and a concentration of state resources on the construction of large, technologically modern theaters under the First Five-Year Plan (1953-1957), I argue that the theaters constructed from 1953-1960 demonstrate a monumental impulse that simultaneously conflicted with the Chinese state’s ostensibly populist call for arts to serve the people and stood as a testament to the power and legitimacy of that state.

Shifting away from monumental theater architecture and technology per se, the second half of the chapter engages with monumentality as a characteristic and function of pieces created for performance in these grand spaces and with commemorative function. Here, I take Tian Han's two Great Leap works as case studies. I argue that these plays served as a testing ground for a new concept of drama that brought together politically mandated themes, the industrial ethos of the Great Leap Forward, and the utopian potentials of new staging technologies.

Socialist Theater Construction in the Early PRC

On October 1, 1949, Mao Zedong stood atop Tiananmen and declared the founding of the People's Republic of China. Thousands of new citizens gathered in the Square beneath the gate, the local audience to the opening act of grand political theatrics that would unfold over the coming decades. Looking out over these crowds, China's new leaders saw not only a sea of willing spectators, but also visions of what the Square – and the city surrounding it – could become. In Mao Zedong's imagination, a forest of chimneys would dominate Beijing's skyline, while Zhou Enlai saw the potentials of a large open space flanked by imposing edifices. According to anecdotes recorded by Cheng Yuangong 成元功, Zhou Enlai's head bodyguard at the time, the newly appointed Premier remarked that: “the largest square in the world should also be the most beautiful, and that it should be the heart of the nation, with a monument, a history museum and a grand national theater at the center, the east and the west respectively.”³ While the comments attributed to Mao Zedong and Zhou Enlai might seem to suggest a difference of opinion between two of the young PRC's most important architects, they are in fact indicative of

³ Cheng Yuangong 成元功, “Guanxin Beijing chengshi jianshe 關心北京城市建設,” in *Zhou Enlai yu Beijing* 《周恩來與北京》 (Beijing: Zhongyang Chubanshe, 1998), 38. Qtd. in Wang Jun 王軍, *Chengji* 《城記》 (Beijing: Shenghuo dushu xinzhi sanlian shudian, 2003), 38. Qtd. and trans. in Jianfei Zhu, *Architecture of Modern China: A Historical Critique* (New York: Routledge, 2009), 81.

the two-pronged approach taken to development in the first decade of the PRC, which emphasized both economic growth and cultural development as essential elements of China's gradual transformation into a modern and socialist nation. Smokestacks and grand theater spaces, both real and imagined, would come to be key material and visual symbols of socialism construction's success.

From the beginning, the theater was central to the cultural dimensions of this vision. By 1949, the belief that theater could play an active role in the creation of a modern Chinese society was well established. Intellectuals of the May Fourth Movement had advocated the use of Ibsenian "social problem plays" as a means of revealing and correcting the ills of contemporary society, and in the early 1940s, Mao Zedong articulated the role of literature and the arts (*wenyi* 文藝) in the communist revolution and the following stage of "new democratic" (*xin minzhu zhuyi* 新民主主義) society. The most famous articulation of these principles came in the "Talks at the Yan'an Forum on Literature and the Arts" in May 1942, in which Mao outlined the "workers, peasants, and soldiers" as the target audiences of all cultural production and its dual imperatives to reflect the lives of these constituencies and to spread revolutionary ideals to them. However, the importance of culture to the Maoist vision of a new democratic China was articulated even earlier in Mao's treatise "Xin minzhu zhuyi lun" 新民主主義論 (On New Democracy), written in January 1940 and published in *Zhongguo wenhua* 《中國文化》 (Chinese Culture), which devotes its latter third to discussing the "national, scientific, and mass" characteristics of ideologically correct culture.⁴ Mao may mention theater directly only twice in the body of the text, but the opening paragraph attributes to the article "the same purpose as the

⁴ Mao Zedong, "On New Democracy," 1940, http://www.marxists.org/reference/archive/mao/selected-works/volume-2/mswv2_26.htm#bm1.

beating of the gongs and drums before a theatrical performance” and thereby frames the (printed) political treatise as an act of performance.⁵ When official attention and Mao’s rhetoric turned towards industrial transformation into a socialist nation after the founding of the PRC, the theatrical performance continued with each proclamation from the raised stage of Tiananmen.

Perhaps due to his personal interest in the theater, Zhou Enlai took an active role in the reform of China’s cultural field.⁶ In the few years immediately following the end of the Chinese Civil War and the founding of the PRC, the new government faced a number of practical tasks, including establishing the enormous bureaucracy necessary to govern a large nation and rebuilding an economy devastated by decades of war and disorder. Under the mandate to advance the gradual “socialist industrialization” of the country and “socialist transformation” of agriculture, handicrafts, industry, and commerce, practical attention focused on land reform, shifting from private to joint private-public or state-owned enterprises, and the development of infrastructure necessary for industrial production.⁷ On the one year anniversary of its founding, the country also found itself again at war when Chinese troupes joined the Korean War on October 1, 1950. Yet, despite these more urgent political, economic, and military concerns, the cultural concerns of the early 1940s carried over into the new state and groundwork for a new cultural bureaucracy was laid even before the PRC was officially founded. In July 1949, 753 representative “culture workers” (*wenyi gongzuozhe* 文藝工作者) gathered at Zhongnanhai 中南海 in Beijing for the First All-China Literature and Arts Workers Representatives Meeting (Di yi

⁵ Ibid.

⁶ Zhou Enlai had participated in theater performances in his youth at Nankai Elementary School (Nankai zhongxue 南開中學) in Tianjin.

⁷ Spence, *The Search for Modern China*, 490; Datong Guan, *The Socialist Transformation of Capitalist Industry and Commerce in China*, China Knowledge Series (Peking: Foreign Languages Press, 1960), 7.

ci quanguo wenxue yishu gongzuozhe daibiao dahui 第一次全國文學藝術工作者代表大會), during which participants formulated a series of broad regulations for the arts and selected members for an All-China Federation of Literature and Arts (Zhongguo wenxue yishujie lianhehui 中國文學藝術界聯合會).⁸ With the founding of the country, the writers and artists also found themselves answering to the newly established Ministries of Propaganda and Culture, the latter of which worked quickly to establish a number institutions such as the Central Drama Academy (Zhongyang xiju xueyuan 中央戲劇學院, est. 1950) and the Beijing People's Art Theater (Beijing renmin yishu juyuan 北京人民藝術劇院, est. 1952).⁹

The creation of cultural bureaucracy and state-sponsored institutions brought the cultural field a greater degree of systematization than it had previously known. Moreover, beyond arranging creative practices within a rationalized system and creating an effective system of control, the establishment of cultural bureaucracy in China specifically aligned literature and the arts with an industrial logic of organization and production. This association between the arts and industry is made most clear in a speech given by Zhou Enlai on July 6, 1949, in which he emphasizes the national task of “developing production” (*fazhan chanye* 發展產業) and states:

Not only do we need to found an All-China Federation of Literature and Arts, we also need to model it on the federation of trade unions, with all kinds of industrial unions beneath it. We need to divide into divisions and establish leagues of literature, theater, film, music, fine arts, dance, etc. Only in this way will we be able to facilitate the

⁸ Guo Moruo 郭沫若 (1892-1978) would serve as the first chairman of the Federation. Kuai Dashen 蒯大申 and Rao Xianlai 饒先來, *Xin Zhongguo wenhua guanli tizhi yanjiu* 《新中國文化管理體制研究》 (Shanghai: Shanghai renmin chubanshe, 2010), 107.

⁹ For an overview of the reorganization of the arts under the PRC, see Chapter 10 in Colin Mackerras, *The Chinese Theatre in Modern Times: From 1840 to the Present Day* (London: Thames and Hudson, 1975). For ethnography detailing the effects of PRC policies for specific performing artists, see Chapter 4 of Francesca R. Sborgi-Lawson, *The Narrative Arts of Tianjin: Between Music and Language* (Burlington, VT: Ashgate, 2011).

progress of our work, facilitate the training of people with talent, facilitate promulgation, facilitate reform...”¹⁰

In Zhou’s formulation, industrial institutionalization brings writers and artists one step closer to Mao’s vision, borrowed from Lenin, of them as “cogs and wheels in the whole revolutionary machine.”¹¹ Literature and the arts are both imagined as industries, with each individual art form figured as a trade subject to standards of efficiency and dissemination that value the logic of the factory over spontaneous creativity.

The Party and the state were also interested in controlling, on a more concrete level, the technical parameters of the arts. For the theater, this meant all levels of production, from content to acting technique to performance spaces. Ideological correctness of content was one major area of concern, especially in popular repertoire carried over from before the founding of the PRC. For instance, the Ministry of Culture formed a Committee for Opera Reform (Xiqu gaijin weiyuanhui 戲曲改進委員會) under the direction of Zhou Yang 周揚 (1908-1989), then Deputy Minister of the Ministry of Culture, which banned initially 12 titles and later published a longer list of plays characterized as banned, in need of revision, or acceptable for performance.¹²

Annual All-China Cultural Administrative Conferences (Quanguo wenhua xingzheng huiyi 全國

¹⁰ The speech was delivered at the at the First All-China Literature and Arts Workers Representatives Meeting, mentioned above. Zhou Enlai 周恩來, “Zai Zhonghua quanguo wenxue yishu gongzuozhe daibiao dahui shang de zhengzhi baogao 在中華全國文學藝術工作者代表大會上的政治報告,” in *Zhou Enlai lunwen ji* 《周恩來論文集》 (Beijing: Renmin wenxue chubanshe, 1979), 24–25.

¹¹ As D.W. Fokkema has noted, Mao’s famous invocation of Lenin seizes upon the particular image of the revolutionary machine and sidesteps the implications of Lenin’s discussion in “Party Organization and Party Literature,” which simultaneously affirms literature’s place in the work of the Party and cautions against the application of a mechanical system for its creation. D.W. Fokkema, *Literary Doctrine in China and Soviet Influence, 1956-1960*, (The Hague: Mouton, 1965), 9; Vladimir Il’ich Lenin, “Party Organization and Party Literature,” in *Collected Works of V.I. Lenin*, vol. 10 (Moscow: Progress Publishers, 1965), 44–49, <http://www.marxists.org/archive/lenin/works/1905/nov/13.htm>.

¹² Fu Jin 傅謹, *Xin Zhongguo xi ju shi, 1949-2000* 《新中國戲劇史, 1949-2000》 (Changsha: Hunan meishu chubanshe, 2002), 10; Bonnie S. McDougall, *The Literature of China in the Twentieth Century* (New York: Columbia University Press, 1997), 292.

文化行政會議) were also held beginning in 1951, passing measures such as the “Provisional Regulations for the Management of Theaters” (Juchang guanli zanxing tiaoli 《劇場管理暫行條例》) in 1951 and “Directive Regarding the Reorganization and Strengthening of Theater Troupes throughout the Country” (Guanyu zhengdun he jiaqiang quanguo jutuan de zhishi 《关于整顿和加强全国剧团的指示》) in 1952.¹³

The former of these hints at a major problem confronting both the theater world and the government in the early years of the PRC: a lack of suitable performance spaces for the drama of a modern socialist nation. Zhou Enlai’s vision of a grand national theater would not be achieved in the first few years of the PRC (nor, for that matter, would Mao’s dream of smokestacks start become reality until the implementation of the First Five-Year Plan in 1953). From 1949-1953, no new theaters were constructed in Beijing. Rather, attention focused on the institutional reorganization and architectural renovations of preexisting theaters, which included small teahouse-style venues suitable for Chinese opera performance, a few urban “new stages” that had been built primarily for Peking Opera performances in the early 20th century, and a number of auditoriums and cinemas that doubled as spaces for live performance.¹⁴ One such example was the True Light Cinema (Zhenguang dianying yuan 真光電影院), originally constructed in 1920 and renamed the “Beijing Theater” (Beijing juchang 北京劇場) in 1950. The house seats 970, with a stage measuring 10.7 meters wide by 12 meters deep.¹⁵ Although short of wing space and

¹³ Kuai Dashen and Rao Xianlai, *Xin Zhongguo wenhua guanli tizhi yanjiu*, 113, 121.

¹⁴ Wu Chunhua 吴春花, “Lao Tianqiao juchang de na xie shi’er--fang Zhongyang xiju xueyuan Li Chang jiaoshou 老天橋劇場的那些事兒--訪中央戲劇學院李暢教授,” *Jianzhu Xuebao* 《建築學報》 4 (2012): 38.

¹⁵ Qinghua daxue tumu jianzhuxi juchang jianzhu shejizu shisheng 清華大學土木建築系劇場建築設計組師生, ed., *Zhongguo huitang juchang jianzhu* 《中國會堂劇場建築》 (Beijing: Qinghua daxue tumu jianzhuxi, 1960), 69.

not constructed specifically for live performance, the Beijing Theater nonetheless became a key theater venue in the early 1950s. The Beijing People's Art Theater (BPAT) production of Lao She's famous *Longxu gou* 《龍鬚溝》 (Dragon Beard Ditch), for example, premiered there on November 13, 1953.¹⁶ Similar cases included the Grand Chinese Theater in Tianjin (Tianjin Zhongguo da xiyuan 天津中國大戲院), which was built in 1936 and was one of the first to be “returned” to the state in 1949, and the Carlton Theater (Ka'erdeng da xiyuan 卡爾登大戲院) in Shanghai, which was built in 1923 and renamed the Yangtze Theater (Changjiang juchang 長江劇場) in 1954.¹⁷

However, the fact that several municipalities other than Beijing *did* devote precious resources to the construction of performance spaces even during this transitional period only further emphasizes the importance of cultural institutions to the new nation and its people. According to the sole monograph devoted to the history of modern Chinese theater history by Lu Xiangdong, a professor at Tsinghua University School of Architecture, large theater or auditorium spaces were constructed in Chongqing, Nanjing, Jinan, Taiyuan, Zhengzhou, Harbin, Chengdu, Tianjin, and other cities in 1951-1952.¹⁸ Few of these spaces were “theaters” per se; instead, as Lu points out, they were largely multi-purpose auditoriums (*litang* 禮堂) and halls

¹⁶ BPAT continued to use the Beijing Theater as late as 1957, when the dress rehearsal for the huaju adaptation of *Rickshaw* (Luotuo xiangzi 《駱駝祥子》) took place there. Beijing renyi dashiji bianjizu 北京人藝大事記編輯組, ed., *Beijing renmin yishu juyuan dashiji di yi juan, 1952-1956* 《北京人民藝術劇院大事記第一輯 1952-1956》 (內部資料妥善保管) (Beijing: Beijing renmin yishu juyuan, 2008), 98–99.

¹⁷ Fu Jin, *Xin Zhongguo xiju shi*, 23; Zhongguo xiquzhi bianji weiyuanhui 中國戲曲志編輯委員會, *Zhongguo xiqu zhi* 《中國戲曲志》, Shanghai juan 上海卷 (Beijing: Zhongguo ISBN zhongxin, 1996), 643.

¹⁸ Lu compiles his list of theaters from a survey published by the Tsinghua University Department of Civil Engineering and Architecture in 1960, which includes construction/renovation dates, technical descriptions, simple blueprints, and photographs of 72 theaters throughout mainland China. Lu Xiangdong 盧向東, *Zhongguo xiandai juchang de yanjin*, 92; Qinghua daxue, *Zhongguo huitang juchang jianzhu*.

(*huitang* 會堂) or housed within cultural clubs (*wenhua julebu* 文化俱樂部) and cultural palaces (*wenhua gong* 文化宮) that also “served the people” by providing space for leisure reading, playing games, dance classes, and other activities. Like the repurposing of movie theaters for live performance, the overlapping functions of these spaces denied the specific technical needs of theatrical productions. Yet, at the same time, locating performances in buildings that doubled as meeting spaces and communal activity centers also embedded the theater at the heart of political and social life.

The long-awaited construction of a large-scale theater in the capital of Beijing in 1953—Tianqiao Theater (Tianqiao juchang 天橋劇場)—naturally made headlines. In newspaper reports published at the time, the construction of this theater was motivated not from the top down, but rather from the desires of “the people.” According to one such article in the *Guangming ribao* 《光明日報》 (Guangming Daily), plans for the theater originated in a report made by local residents at the beginning of 1952, which noted a lack of entertainment venues in the workers’ neighborhoods in Tianqiao district in southern Beijing.¹⁹ In response to these reports, the government approved the construction of one theater and two cinemas, as well as the renovation of another theater near Qianmen. Since the theater was to be built in the capital, it received a relatively generous budget of 70,000 *yuan*.²⁰ Construction began in July 1953, and the official opening ceremony was held on January 16, 1954.²¹ The new three-story theater seated 1700 and featured stage lifts,

¹⁹ Wang Yongde 王泳德, “Zhubu di manzu laodong renmin dui wenhua shenghuo de yaoqiu, Beijing Tianqiao daxing juchang luocheng jijiang kaimu 逐步地满足劳动人民对文化生活的要求,北京天桥大型剧场落成即将开幕,” *Guangming ribao* 《光明日报》, December 28, 1953.

²⁰ Wu Chunhua, “Lao Tianqiao juchang de na xie shi’er,” 38.

²¹ “Beijing Tianqiao juchang kaimu,” *Guangming ribao* 《光明日报》, January 17, 1954.



Figure 13 Tianqiao Theater, Beijing (Source: *Zhongguo huitang juchang jianzhu*, 1960)

automatic lighting controls, and a well-equipped fly-space, with 25 pipes for hanging scenery.

[Figure 13]

An ideologically correct impetus for government investment in the arts, “the people” clamoring for a new theater is in fact only part of the story. Another key factor in government attention to the construction of new theater spaces was the return in 1952 of the designers who had traveled to Eastern Europe with the Chinese Youth Arts Troupe, discussed in the introduction. Set designers Li Chang 李暢, who trained at the National Academy of Drama (Guoli xiju zhuanke xuexiao 國立戲劇專科學校) in Chongqing and was a faculty member at the Central Drama Academy, and Chen Zhi 陳治 became the primary technical theater consultants for the Ministry of Culture, and participated in the design and construction of major theaters in

Beijing and around the country.²² In a memoir recounting his experiences, Li Chang notes: “You almost might say that without the experience brought back by the Youth Arts Troupe, we could not have constructed theaters that could match up to contemporaneous European theaters, like Tianqiao Theater, Capital Theater, People’s Theater, Beijing Workers’ Association, etc., in such a short time.”²³ While in retrospect this claim may be read with a tone of pride, Li Chang also recalls a more conflicted feeling at the time. When older members of the troupe commented to Li Chang that their audiences were not cheering for the quality of performance, but rather in support of China’s revolutionary successes and liberation, Li Chang came to feel a sense of unease: “while taking pride in our country, I also saw a great gap in our profession.”²⁴ This professional gap was perhaps less an issue of content than of form; the fact that the troupe attended a Czech production of *Baimaonü* 《白毛女》 (The White-Haired Girl), with Czech actors, while on tour suggests that the pieces themselves were very well received. Thus, the disparity must have been on the level of either performer technique or overall production value. For a designer like Li Chang, this sense of lack was most keenly felt in comparison with the technical capacities of Eastern European and Soviet theater spaces, which could make possible higher quality theatrical production.

A similar sense of professional – or technical – lack came to be a major factor in the construction of the Tianqiao Theater. Shortly after its grand opening in January 1954, the theater came face-to-face with its own inadequacy when the upcoming visit of two performing arts

²² The National Drama Academy (Guoli xiju xueyuan 國立戲劇學校) was established by the KMT in Nanjing in 1935.

²³ Li Chang 李暢, “Xuexi jiejian Ouzhou xianjin de wutai meishu gongzuo 學習借鑑歐洲先進的舞台美術工作,” in *Dang women zaici xiangju: Zhongguo qingnian wengongtuan chufang 9 guo yinian ji* 《當我們再次相聚: 中國青年文工團出訪9國一年記》, ed. Shi Yajuan 石雅娟 (Beijing: Wenhua yishu chubanshe, 2004), 111.

²⁴ *Ibid.*, 108.

groups from Soviet Union was announced. In commemoration of the fifth anniversary of Sino-Soviet diplomatic relations and for the opening of the Soviet Economic and Cultural Construction Achievements Exhibition (Sulian jingji ji wenhua jianshe chengjiu zhanlanhui 蘇聯經濟及文化建設成就展覽會), the Soviet National People's Dance Troupe and the Stanislavsky and Nemirovich-Danchenko Moscow Music Theater were to visit Beijing, with the latter to perform three operas and three ballets at Tianqiao Theater.²⁵ The visitors required a stage that would fit their large set pieces, as well as enough wing space to store the sets and equipment for all six productions while allowing them to transition between performances in only 3-4 hours. At the time, the Tianqiao Theater was the largest in Beijing, but even it could not meet the needs of the touring Soviet productions. In the space of only a few months, the theater was renovated to bring it up to “international standards” with expansion of the wings, further improvements to the lighting and fly systems, addition of spaces for rehearsal and wardrobe preparations, and enhancement of exterior decorations.²⁶ The performances in the renovated space were a success, and members of the troupe gave talks on theater design and management during their time in Beijing. These talks were transcribed and published, along with detailed descriptions of the Music Theater's scenic construction techniques, in 1957.²⁷ Just as confrontation with Japanese and Western military prowess and modern scientific knowledge engendered a feeling of national

²⁵ The three operas were *Eugene Onegin*, *The Tempest*, and *The Cossack Beyond the Danube*, and the three ballets were *Swan Lake*, *Hunchback of Notre Dame*, and *Doctor Aybolit* (Doctor Ouch). Wu Chunhua, “Lao Tianqiao juchang de na xie shi'er,” 38; “Wei yingjie Sulian liang da yishu tuanti lai woguo yanchu, Beijing liang zuo juchang de xiujian gongcheng zheng jiajin jinxing 為迎接蘇聯兩大藝術團體來我國演出，北京兩座劇場的修建工程正加緊進行,” *Renmin ribao* 《人民日報》，September 5, 1954.

²⁶ “Wei yingjie Sulian liang da yishu tuanti.”

²⁷ The collection of essays was compiled by the Scenic Design group of the Dramatists Association Artists Committee (Zhongguo xijujia xiehui yishu weiyuanhui wutai meishu zu 中國戲劇家協會藝術委員會舞台美術組) and is marked as “internal study material” (*neibu xuexi ziliao* 內部學習資料). *Wutai meishu gongzuo jingyan jianjie* 《舞台美術工作經驗簡介》 (Beijing: Zhongguo xijujia xiehui yishu weiyuanhui, 1957).

shame and propelled widespread efforts to speed progress in the late Qing, here too, on a smaller scale, a feeling of inadequacy spurred change.

The construction and renovation of the Tianqiao Theater coincided with a spate of theater construction in Beijing and, according to Lu Xiangdong, signaled a significant shift in the conceptualization of theater space (*juchang guannian* 劇場觀念).²⁸ From 1953 forward, the theater was recognized as a profession requiring a professional space with certain technical specifications. Some theater professionals even became convinced that the key to theater development was the installation of the proper “hardware,” leading to what Lu terms a budding “technology worship” (*jishu chongbai* 技術崇拜) among Chinese theater designers and technicians.²⁹ Likewise, Chinese actors, playwrights, and directors, across genres, were turning their attention to questions of technique and craft. A key example of the later can be found in the trend in *huaju* that drama scholar Hu Xingliang 胡星亮 has dubbed “System fever” (*tixi re* 體系熱).³⁰ In this case, the “system” in question is not the cultural bureaucracy, but the Stanislavsky System (*Sitannisilafusiji tixi* 斯坦尼斯拉夫斯基體系) of acting. Thus, the theater world’s “interest in Soviet technology” was manifest as a desire to absorb Soviet expertise, both in technical theater – as with the lectures delivered by the visiting Moscow Music Theater in 1954 – and in performance techniques.

This shift was not limited to the performing arts. In her study of the cultural bureaucracy and politicized institutionalization of painters in the early years of the PRC, for example, Julia F.

²⁸ Lu, *Zhongguo xiandai juchang de yanjin*, 92–93.

²⁹ *Ibid.*, 100.

³⁰ Hu Xingliang 胡星亮, *Xiandai xiju yu xiandai xing* 《現代戲劇與現代性》 (Beijing: Renmin wenzue chubanshe, 1994), 150.

Andrews notes a similar technical shift in the visual arts. She specifically cites the year 1953 as marking “an important transition from a rigid emphasis on popularized subjects and forms to the administration of art as a professional, specialized undertaking” and attributes this change to a nationwide interest in Soviet technology.³¹ This year also marked the beginning of the First Five-Year Plan (1953-1957); to be sure, the focus of state planning during this period was on hastening economic development by building up the country’s industrial and agricultural sectors, but “culture, education, and public health” projects were also included on the list of government-driven initiatives. Under the more systematic allocation of resources and goal-oriented policies of socialist planned economy, theater construction was transformed into a quantifiable measure of progress. An English-language propaganda publication on the First Five-Year Plan, for example, proclaims a goal of reaching 2,078 theaters, 896 cinemas, and 5,279 cinema projection teams by the end of 1957, complete with illustrations. Given the estimate of 891 theater buildings existing as of 1949 and the relatively modest number constructed during the early 1950s, the goal of reaching over 2000 theaters by 1957 seems ambitious. Yet, according to statistics compiled by the Tsinghua University Department of Civil Engineering and Architecture in 1960, construction surpassed its target, with the total number of “professional theaters” (*zhuan ye juchang* 專業劇場) reaching 2,227 in 1957 (and a further increase to 2,800 by 1959).³²

³¹ Julia Frances Andrews, *Painters and Politics in the People’s Republic of China, 1949-1979* (Berkeley, CA: University of California Press, 1994), 110.

³² Compared to national estimates of 386 theaters before the Second Sino-Japanese War and 891 theaters as of 1949. Given the disparity in number of cinemas to be constructed, further comparison might be drawn between theater and film. Theatrical activities flourished, while technical difficulties made film production lag. As late as 1957, Mao himself complained publicly about the paucity of domestic film production, especially in comparison to Japan. Qinghua daxue, *Zhongguo huitang juchang jianzhu*, 26–28; Mao Zedong 毛澤東, *Mao Zedong wenji* 《毛澤東文集》, vol. 7 (Beijing: Renmin chubanshe, 1999), 257. Cited in Kuai Dashen and Rao Xianlai, *Xin Zhongguo wenhua guanli tizhi yanjiu*, 10.

Among these, the more prominent and best funded remained those in Beijing, including the construction of the aptly titled Capital Theater in 1954-55. Already aligned by name and location with the political center, the theater's construction process only further demonstrates the center's interest in the technical details of theater making. Soon after Ministry of Culture Deputy Minister Zhou Yang and Beijing Municipal Vice-Mayors Zhang Youyu 張友漁 and Wu Hanlian 吳晗聯 applied for permission to construct a theater in Beijing specifically for *huaju* performances, BPAT director Cao Yu and vice-directors Jiao Juyin and Ouyang Shanzun found themselves in the office of the Premiere himself, Zhou Enlai, discussing their plans.³³ At Zhou's behest, they drew up a plan to increase the size of the planned theater from 900 seats to 1200 seats, and to order sound and lighting equipment directly from manufacturers in East Germany.³⁴ With Zhou's approval, the scale and budget of the theater project were increased, and, during construction, eight professionals from East Germany assisted with the installation of this equipment.³⁵ According to these original plans, the theater space was intended for proprietary use by BPAT; however, as Zhang Fan notes in an article reminiscing on the theater's construction, this allocation caused some discord among other theater troupes in Beijing and with leadership within the Ministry of Culture.³⁶ In fact, when the theater officially opened in November 5, 1955, with a performance by the Soviet "Little White Birch" (Xiaobai huashu 小白

³³ 8/31/16 12:19 AM Zhang Fan 張帆, "Yiduan hualuo shijia de wangshi--ji Shoudu juchang luocheng qianhou 一段花落誰家的往事——記首都劇場落成前後," *Zongheng* 《縱橫》 4 (2007): 54.

³⁴ In addition to the written records of the events leading up to the construction of the Capital Theater, documents such as the approval letter from the Beijing municipal government, Cao Yu's letters to Zhou Enlai, and the list of technical requirements for the theater are preserved in the BPAT Theater Museum at the Capital Theater.

³⁵ From August 1949 to the end of 1958, there were some 11,527 advisors from the USSR and other foreign countries in China advising on a range of projects, from industry and economics to education and culture. Kuai Dashen and Rao Xianlai, *Xin Zhongguo wenhua guanli tizhi yanjiu*, 142; "Shoudu Juchang Jiancheng 「首都劇場」建成," *Xijubao* 《戲劇報》 11 (1955): 42-43.

³⁶ Zhang Fan, "Yiduan hualuo shijia de wangshi," 55.

樺樹) dance troupe, its ownership was yet uncertain.³⁷ The Ministry of Culture attempted to retain control over the space, promising the renovated Beijing Theater to BPAT in its place; again, it was the personal intervention of Zhou Enlai that resulted in management of the theater being officially turned over to BPAT in September 1956.

At the time of its construction, the Capital Theater was heralded as one of the more “complete,” or “well-provisioned,” (*wanbei* 完備) theater spaces in the country. An article commemorating the completion of the Capital Theater, published in the trade journal *Xijubao* 《戲劇報》 (Theater Journal) in November 1955, for example, shows that it was precisely the technical capacities of the theater that were most of interest. After only a brief description of its exterior and floor plan, which in the same breath lauds the buildings “simplicity” and its grand size, the article goes on to enumerate the specifics of its inner workings: hidden speakers and a climate control system in the house, a mechanically contracting proscenium and 16m-diameter revolving stage, more than 60 hanging pipes and the newest in lighting control technology, wireless headsets linking different parts of the stage and a stage feed in every dressing room.³⁸ The technical specifications of the theater receive similar attention in the introduction to materials later published by the Tsinghua University Department of Architecture (today, School of Architecture).³⁹ Also home to one of the premiere *huaju* troupes, the Capital Theater would go

³⁷ “Beijing Shoudu juchang juxing kaimushi: Sulian ‘Xiaobaishu’ wudao yuan zuo biaoyan 北京首都劇場舉行開幕式：蘇聯‘小白樺樹’舞蹈團作表演,” *Guangming ribao* 《光明日報》, November 6, 1955.

³⁸ “Shoudu juchang jiancheng.”

³⁹ The Tsinghua book does note that despite best efforts, there were some deficiencies in the sound and lighting systems. In addition, in the post-Reform era in the PRC, the general opinion seems to be that the theaters of the time lagged far behind the international standard and that China did not “catch up” until the 1980s. Qinghua daxue, *Zhongguo huitang juchang jianzhu*, 24.

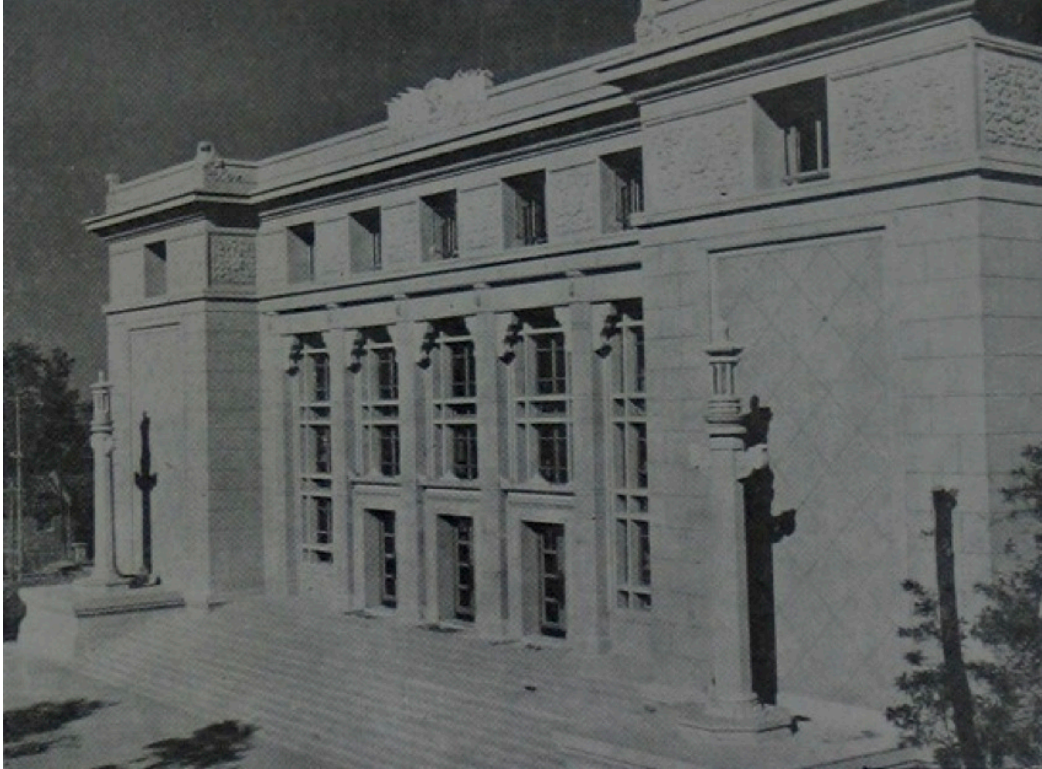

Figure 14 Capital Theater, Beijing (Source: *Zhongguo huitang juchang jianzhu*, 1960)

on to house some of the most important theatrical events of later decades.

If the interior of the Capital Theater boasted the best (possible) modern technologies, its exterior gestured in the direction of a different kind of hyperbole. Like the Tianqiao Theater, with its three stories, columned exterior, and 1700-person house, the Capital Theater and many others constructed during this period exhibit an architectural monumentality that drew both on traditional Chinese aesthetics and Soviet neoclassical design. [Figure 14] At the time, the theater's grandeur also contributed to debates over economy and "national style" among Chinese architects of the 1950s. The theater's front façade features a decorative pillar-and-beam frame, and in the decorative detailing ringing the building's upper levels. Two imposing cloud pillars (*huabiao* 華表) flank the entryway, both invoking solemnity of an imperial palace or tomb complex and adapting the traditional form into smoother, more stylized structures. However,

where typical *huabiao* would be topped with zoomorphic figures, the Capital Theater's pillars feature miniature pavilions that speak more to the influence of Soviet theater architecture than Chinese tradition. The model for these pavilions may perhaps be found in the Navoi Theater in Tashkent, Uzbekistan; according to interviews conducted by Lu Xiangdong, lead architect Lin Leyi 林樂義 primarily drew from that design when working on the Capital Theater.⁴⁰ According to Lu, further influence of the Navoi Theater can be seen most clearly in the floor plan for the Capital Theater, which closely matches that of the Navoi, while the broad flight of stairs at front and monolithic size echo forms typical to the Stalinist period.

In borrowing Soviet style and monumentality, the Capital Theater also anticipates the grandest building project of the early PRC: the construction of the Monument to the People's Heroes, completed in May 1958, and the Ten Great Buildings, in celebration of the PRC's 10th anniversary in October 1959, on Tiananmen Square.⁴¹ As art historian Wu Hung has shown in his history of political space in Beijing, Tiananmen Square after 1949 "was architecturally transformed into a dominant official space – a monumental complex that embodied the country's political ideology and consolidated its Communist leadership."⁴² Conceived as commemorative

⁴⁰ The Navoi Theater opened to the public in November 1947. Lu Xiangdong attributes confirmation of this detail to Li Daozeng 李道增, architect and professor at Tsinghua University School of Architecture, whom Lu Xiangdong interviewed for his architectural history of Chinese theaters. I am in turn indebted to Professor Lu for meeting with me in July 2013 and for help locating much of the Chinese-language material on which the architectural discussion in this chapter is based. See Lu, *Zhongguo xiandai juchang de yanjin*.

⁴¹ The decision to construct the Ten Great Buildings was made on September 5, 1958. As multiple sources note, the precise list of buildings in the original plan differed from ten structures now considered the Ten Grand Buildings: (1) the Great Hall of the People, (2) the Museum of Revolutionary History, (3) the Agricultural Exhibition Hall, (4) the People's Liberation Army Museum (People's Revolutionary Military Museum), (5) the Minority Cultural Palace, (6) the State Guest House, (7) the Workers' Stadium, (8) the Overseas Chinese Hotel (Union Building), (9) the Chang'an (Minzu) Hotel, and (10) the Beijing Railway Station. The list has been adjusted to account for the buildings that were actually built in 1959. See Shu Jun 樹軍, *Tiananmen guangchang lishi dang'an* 《天安門廣場歷史檔案》 (Beijing: Zhonggong zhongyang dangxiao chubanshe, 1998). Cited in Wu Hung, *Remaking Beijing: Tiananmen Square and the Creation of a Political Space* (Chicago: The University of Chicago Press, 2005), 112.

⁴² Wu, *Remaking Beijing*, 9.

projects, the “Ten Great Buildings” were meant to project the power and legitimacy of the Chinese Communist Party; at the same time, the speed of their design and construction enacted the “more, faster, better, cheaper” (*duo, kuai, hao, sheng* 多快好省) directive of the Great Leap Forward, which had begun in early 1958. Functional, certainly, these structures can also “be considered political monuments and ‘exhibition architecture’ owing to their inherent symbolic and ceremonial tasks, their strategic locations in the capital and their expositional architectural style.”⁴³ That is to say, architectural technology becomes a kind of performance itself.

Yet, after only one Five Year Plan, the Chinese Communist Government in 1959 was hardly akin to those well-established bastions of imperial power that had in the ancient world honored themselves with grand monuments. Instead, the erection of ten monumental, commemorative Great Buildings in honor of a state power very much still in the process of formation involved a significant future projection and a preemptive reconstruction of space to suit it. As Zhu Jianfei puts it: “The Square as it emerged in 1959 marked a radical shift from one space to another, from the past to a future yet to be fully articulated.”⁴⁴ A similar temporal trick had been performed with the Monument to the People’s Heroes, initially conceived a decade earlier. In March 1949, months before the official founding of the PRC, a special planning committee was organized, as Wu Hung puts it, “to design a commemorative monument for the future regime” – what would later become known as the Monument to the People’s Heroes.⁴⁵ Mao then laid the first foundation stone in the designated location, south of the Tiananmen Gate, on September 30, 1949. As Wu Hung has argued, the anticipatory creation of the monument

⁴³ Ibid., 108.

⁴⁴ Zhu, *Architecture of Modern China*, 99.

⁴⁵ Wu Hung, “Tiananmen Square: A Political History of Monuments,” *Representations* 35 (1991): 95.

allowed it to be present in Tiananmen Square to bear witness to Mao's announcement of the country's founding from atop the Gate on October 1, 1949.⁴⁶ When all other witnesses had passed away, the (now completed) monument would still stand as a permanent witness to the beginning of the glorious present and preemptive commemoration of any and all future events that would happen around it.

Nowhere was this future projection in stronger operation than with the National Theater, originally envisioned by Zhou Enlai in 1949 and included in plans for the Ten Great Buildings nearly a decade later.⁴⁷ A design competition for the project was held in 1958, with detailed plans for a 3000-seat "grand theater" (*da juyuan* 大劇院) published in the *Architectural Journal* and commemorated in a series of volumes on theater architecture compiled by the Tsinghua Department of Architecture in the early 1960s.⁴⁸ One of these volumes, entitled *Zhongguo huitang juchang jianzhu* 《中國會堂劇場建築》 (Chinese Auditorium and Theater Architecture), foregrounds the designs by placing it second amongst over a hundred other spaces, after only the Great Hall of the People, and including multiple full-color renderings of the interior and exterior. As the renderings demonstrate, the 3000-seat National Theater was yet another iteration of hybridized Soviet and Chinese architectural styles with a total area of 40,000m² and an enormous stage: 40m wide by 30m deep, with additional depth provided by a 22m x 22m revolving stage to its rear (dimensions approximately equivalent to the 3,800-seat

⁴⁶ Ibid., 100–101. Large sections of this article, including discussion of the Monument, are also included in Wu's *Remaking Beijing*, cited above.

⁴⁷ Other buildings that were mentioned in plans but not built for the 10th anniversary include a Science and Technology Hall, a National Gallery, a Movie Palace, and the Xidan Department Store. The Soviet Union Exhibition Hall, which opened in 1958, was also included in the original plan but is not generally considered one of the Ten Great Buildings.

⁴⁸ A second, 2300-seat theater was also designed during this period. Lu Xiangdong discusses the planning of national theater at length in his monograph. See Lu, *Zhongguo xiandai juchang de yanjin*, 122–144.

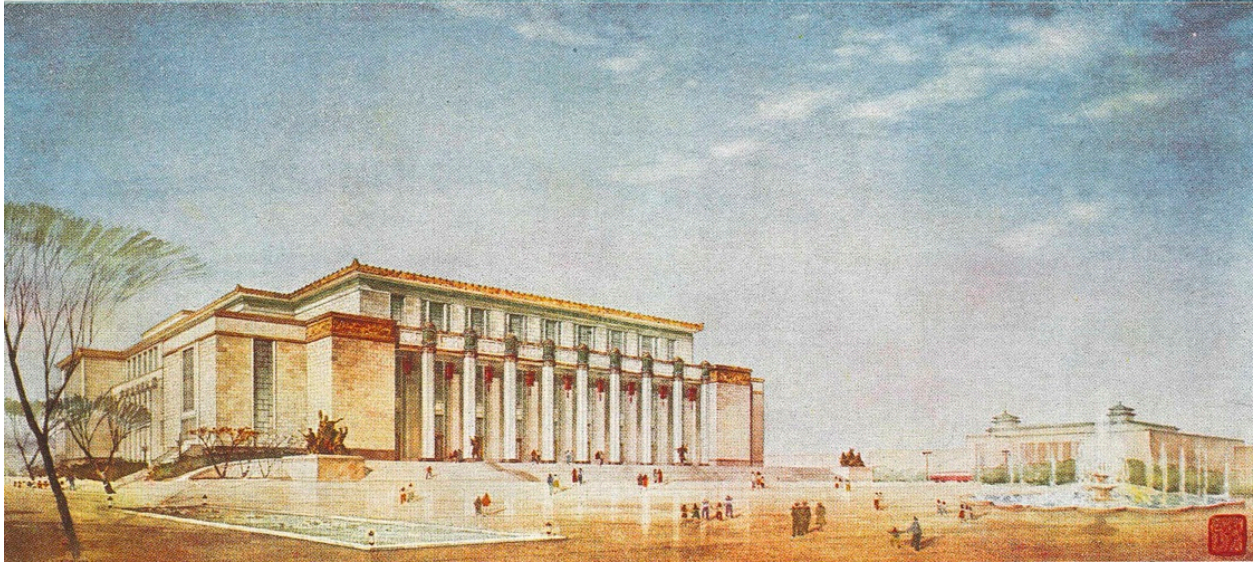

Figure 15 Renderings of the 3000-seat National Theater, Qinghua University Department of Architecture (Source: *Zhongguo juchang huitang jianzhu*, 1960)

Metropolitan Opera House at Lincoln Center).⁴⁹ [Figure 15] At the same time, as with the Capital Theater, its designers were also concerned with the inner mechanics of an appropriately “modern” theater for their glorious socialist nation. In fact, in this case, it was not the designers but the Party that mandated the degree of technical sophistication for the theater. According to a section on “Modern Stage and Backstage Design” in the report published by the design group in the *Jianzhu xuebao* 《建築學報》 (Architectural Review), it was the Ministry of Culture description of the project (presumably released at the beginning of the design competition) that stipulated more than 23 sets of mechanical equipment and ten different electrical systems for the theater. The former included stage lifts, the revolving stage, an extensive hanging pipe system, and a moving proscenium, among other equipment, and the latter, wiring for systems such as lighting, announcements, and television. These requirements far surpassed the extant systems at the Tianqiao Theater and the Capital Theater, with some being implemented for the first time in

⁴⁹ Qinghua daxue, *Zhongguo huitang juchang jianzhu*, 39.

China.⁵⁰ The Ministry of Culture directive demonstrates that it was not only theater professionals and technical specialists who were concerned that the technologies of the theater; when it came to planning for a theater to represent the nation, technological modernity was an integral part of the leaderships' imagination of the space.

Guan Hanqing (1958) as Monumental Theater

At the same time, such a carefully imagined theater tempts us with the question of what kind of performances might have graced its well-provisioned stage, if it had been built. How would have unprecedented advancements in spatial technologies affected the production of theater? How would monumentality, as a material parameter and ideological orientation, have found its way into the work of playwrights, directors, actors, designers, and audiences? Unfortunately, while the architects' plans give an excellent sense of the concrete plans and some sense of the aesthetics and ideologies framing them, they stop short of taking up the mantle of the theater producer or director. However, by examining the widespread phenomenon of commemorative performance that took place throughout the first 17 years of the PRC—and indeed, continues to this day—we can gain insight into the monumental theater envisioned and, in some cases, put into practice under the direction of the Communist state.

One key instance of this lies in the June 1958 performance of *Guan Hanqing*, a new play by leading PRC dramatist Tian Han composed in honor of the Yuan dynasty playwright's 700th anniversary. Set during the late 13th century, *Guan Hanqing* metatheatrically stages a key moment in Chinese theater history and recasts the creative process of its eponymous Chinese

⁵⁰ Qinghua daxue jianzhu xi juyuan sheji zu 清華大學建築系劇院設計組, "Da juyuan sheji fang'an jieshao 大劇院設計方案介紹," *Jianzhu xuebao* 《建築學報》 4 (1960): 14.

playwright as a revolutionary act.⁵¹ The play opens on a small street just outside of the Dadu (contemporary Beijing) city wall, where Guan Hanqing and local residents bear witness to the unjust execution of a chaste and filial young woman, Xiaolan. Deeply troubled by the event, Guan resolves to write a play extolling the virtues of a similar character, whom he names Dou'E, and condemning the corrupt political system that sends her to her death. Guan is a doctor by trade, but has close ties to the theater world and occasionally even takes the stage himself; he draws on these connections to help him polish the script and eventually to perform it. When he pitches the idea to courtesan and actress Zhu Lianxiu 朱廉秀, she responds with a line that would be quoted in nearly every review of *Guan Hanqing*: "If you dare to write the play, then I'll dare to stage it!"⁵² The performance of *Dou'E Yuan* 《竇娥冤》 (Injustice to Dou'E), one of the historical Guan Hanqing's most famous pieces, turns into a truly daring deed when the actors are invited to stage it at one Jade Fairy Tower (Yuxianlou 玉仙樓) as a special performance for the mother of the Mongol prime minister. The old dowager loves the play, but Deputy Prime Minister Akham (Ahema 阿合馬) is less pleased by its thinly veiled jabs at the ruling system of which he is a part. He commands Guan and Zhu to amend the script and stage the revised version for him; when they refuse to change even a word, Akham sentences Guan and Zhu to execution and orders the eyes of Zhu Lianxiu's disciple, Sai Lianxiu 賽廉秀, gouged out. After a moving scene in jail, during which Guan and Zhu pledge undying commitment to justice and to one

⁵¹ This summary is based on the first published, nine-scene version of the script, which came out in *Play Monthly* in May 1958. Discrepancies between this version, later published editions, and performance scripts will be discussed below. Tian Han 田漢, "Guan Hanqing 《關漢卿》," *Juben* 《劇本》 5 (1958): 2–29.

⁵² Tian Han, "Guan Hanqing," in *The Columbia Anthology of Modern Chinese Drama*, ed. Xiaomei Chen, trans. Amy Dooling (New York: Columbia University Press, 2010), 609.

another, a lucky confluence of events results in the commutation of their death sentences and two depart to exile in Hangzhou.

The Beijing People's Art Theater premiered *Guan Hanqing* at the Capital Theater on June 28, 1958 following a long day of commemorative festivities, which included the opening of an exhibition on Guan Hanqing at the North Gate Building, or Building of the Gate of Divine Might (Shenwu men lou 神武門樓) of the Forbidden City and a large conference at the CPPCC Assembly Hall, during which both political and artistic leaders delivered addresses.⁵³ For the theater community, the play carried particular significance in that it marked Tian Han's return to writing *huaju* after a hiatus of more than a decade. Educated in Japan and an early proponent of Chinese *huaju* in the 1920s, Tian Han formed the Southern Society (Nanguo she 南國社), took an active role in the left-wing drama during the 1930s, and went on to be a prominent member of the cultural bureaucracy under the Chinese Communist Party.⁵⁴ In addition to penning numerous *huaju* scripts, Tian Han was one of the architects of opera reform in the early 1950s and composed several pieces for Peking Opera, such as a revolutionary adaptation of *Baishe zhuan* 《白蛇傳》 (The Legend of the White Snake).⁵⁵ He also turned to scholarly projects, spearheading an effort to collect and publish historical materials from Chinese *huaju* in

⁵³ A detailed description of the festivities may be found in "Shoudu longzhong jinian shijie wenhua mingren Guan Hanqing 首都隆重紀念世界文化名人關漢卿," *Xijubao* 《戲劇報》 11–12 (1958): 11.

⁵⁴ For detailed studies of Tian Han's life and work, see for example: Dong Jian 董建, *Tian Han zhuan* 《田漢傳》 (Beijing: Beijing shiyue wenyi chubanshe, 1996); Liang Luo, *The Avant-Garde and the Popular in Modern China: Tian Han and the Intersection of Performance and Politics* (Ann Arbor: University of Michigan Press, 2014).

⁵⁵ Tian Han first became involved in revolutionary opera reform when he arrived in the Liberated Areas in November 1948 and took a more active role after he became chairman of the Dramatists Association (abbreviated as *juxie* 劇協) in July 1949. For a description of Tian Han's work on drama reform in the early 1950s and opera compositions, see Dong Jian, *Tian Han zhuan*, 737–775.

commemoration of the genre's 50th anniversary in 1957, before writing several more plays, including *Guan Hanqing*, in the late 1950s.

Beyond the theater world, the celebration of Guan Hanqing's 700th anniversary carried additional import in that it both united the nation in an act of cultural commemoration and drew international attention to Chinese culture, both historical and contemporary. As with major national holidays like May Day and National Day, parallel celebrations of Guan's 700th Anniversary occurred in cities around the country on the same day. According to newspaper reports from Shanghai, for example, a large meeting was held at the Yangtze Theater on the morning of June 28, followed by performances including a production of Tian Han's *Guan Hanqing* by the Shanghai People's Art Theater (SPAT).⁵⁶ On the international front, Guan had been designated a "giant of world culture" by the World Peace Council, a largely socialist group made up of representatives from individual national councils; according to a 1957 *Pravda* article on the Socialist Peace Committee, these international cultural celebrations called for precisely combination of memorial meetings, lectures, performances, and publication of related materials that we find in the Beijing and Shanghai activities in honor of Guan Hanqing.⁵⁷ The privilege of opening celebrations in fact went to Moscow, where a program on June 20, 1958 included musical and dance pieces, as well as a scene from *Injustice to Dou'E* performed by actors of the

⁵⁶ "Wenhua jie jinchen juxing jinian Guan Hanqing dahui: Guan Hanqing zuopin aizeng fenming, zuguo gudian xiju de zhengui caifu 文化界今晨舉行紀念關漢卿大會：關漢卿作品愛憎分明，祖國古典戲劇的珍貴財富," *Xinmin wanbao* 《新民晚報》，June 28, 1958.

⁵⁷ He was the second premodern Chinese writer to be feted in this manner; five years earlier, in 1953, poet Qu Yuan (c. 340-277 BCE) had also received this honor. Other celebrated anniversaries included: the 100th anniversary of the death of Russian composer M. I. Glinka, the 150th anniversary of the birth of Henry Longfellow, the 250th anniversary of the birth of Italian dramatist and theatrical figure Carlo Goldoni, the 300th anniversary of the publication of the works of Czech pedagogue and philosopher Jan Amos Komensky, the 250th birthday of Swedish scientist Carl Linne, [Linnaeus], the 200th anniversary of the birth of William Blake, and the 100th anniversary of the death of Auguste Comte. "Peace Front: In Soviet Peace Committee," *The Current Digest of the Russian Press* 10, no. 9 (April 17, 1957): 24–25. Reprinted from *Pravda* (March 7, 1957): 4.

“Stanislavsky Theater,” i.e. the Stanislavski and Nemirovich-Danchenko Moscow Academic Music Theater (*Московский Академический Музыкальный Театр имени народных артистов К. С. Станиславского и В. И. Немировича-Данченко*) and, according to reports, festivities extended beyond the capital.⁵⁸

In the case of Guan Hanqing, the international attention of the World Peace Council helped to revive domestic interest in the playwright and his works.⁵⁹ The year surrounding his anniversary celebration, saw the printing of numerous articles on his life and works in a range of periodicals.⁶⁰ In more popular venues, such as daily newspapers, a unified image of the playwright was promoted by repeated use of a single portrait by artist Li Hu 李斛 and a boilerplate biography [Figure 16].⁶¹ Several collections of his poetry and drama, such as *Guan Hanqing xiqu ji* 《關漢卿戲曲集》 (The Collected Operas of Guan Hanqing), were published, and films were made of his plays performed in contemporary opera forms. Major newspapers

⁵⁸ K. Yifannuofu 伊凡諾夫, “Sulian renmin relie jinian Guan Hanqing 蘇聯人民熱烈紀念關漢卿,” *Xijubao* 《戲劇報》 12 (1958). See also “Sulian ge jieji hui jinian Guan Hanqing 蘇聯各階級會紀念關漢卿,” *Renmin ribao* 《人民日報》, June 22, 1958; Rudolf G. Wagner, *The Contemporary Chinese Historical Drama: Four Studies* (Berkeley, CA: University of California Press, 1990), 8.

⁵⁹ In the mid-to-late 1950s, there seems to have been a certain interest in classical Chinese literature in the Soviet Union. See for example, an article originally published in *Izvestia* and reprinted in translation in *The Current Digest of the Russian Press*: Olga Rusanova, “Great Heritage: Chinese Classical Literature in Russian,” *Current Digest of the Post-Soviet Press*, Eastview Online database, 8, no. 23 (1956): 29–30. Eastview Online database.

⁶⁰ Guan Hanqing 關漢卿, *Guan Hanqing xi qu ji* 《關漢卿戲曲集》, ed. Wu Hsiao-ling 吳曉鈴 (Beijing: Zhongguo xiju chubanshe, 1958). An article announcing the publication was printed in *Renmin ribao* on October 26, 1957. Zhi Bin 志彬, “Guan Hanqing xiqu ji shiyi yue chuban 關漢卿戲曲集十一月出版,” *Renmin ribao* 《人民日報》, October 26, 1957.

⁶¹ For example, published photographs show Li Hu’s painting hanging above the stage at the commemorative ceremonies in both Beijing and Shanghai. “Shoudu longzhong jinian shijie wenhua mingren Guan Hanqing,” 11; “Wenhua jie jinchen juxing jinian Guan Hanqing dahui.”



Figure 16 Guan Hanqing image by Li Hu, here pictured in the Great Hall of the People
 (Source: “Shoudu longzhong jinian shiji wenhua mingren Guan Hanqing,” *Xijubao* 12 (1958): 11)

like *Renmin ribao* 《人民日报》 (People’s Daily) even featured notices detailing progress of plans for official celebrations and, after the fact, reports on their success. Ubiquitously labeled “great playwright Guan Hanqing” (*weida juzuojia Guan Hanqing* 偉大的劇作家關漢卿), or a close variation thereof, the playwright acquired a distinct rhetorical association with state ideology, political power, and “the great Chairman Mao” (*weida de Mao zhuxi* 偉大的毛主席) himself.

In commemorative impulse and grand rhetoric, then, the 1958 celebration of Guan Hanqing shares something of the monumental impulse that drove the construction of the Monument to the People’s Heroes and the Ten Great Buildings at Tiananmen Square. While there is no mausoleum or statue to make material the memory of the “great” cultural figure, I would like to suggest that the artistic production surrounding his 700th Anniversary—specifically, the composition and performance of Tian Han’s *Guan Hanqing*—may actually

fulfill the same primary functions as a monument. Here, my notion of “monumental theater” may call to mind both the architectural debates on “monumentality” earlier discussed and the concept of “monumental style” developed by Darrel William Davis in his work on Japanese cinema of the 1930s-1940s.⁶² According to Davis, film came to Japan as an inherently modern, perhaps even modernist, technology infused with Western modes of representation; the “monumental style” was one result of a clash between cinematic modernity and a premodern, indigenous national identity and aesthetics.⁶³ Films in the monumental style constitute a small but significant segment of Japanese film production before and during World War II, which are characterized by their incorporation of traditional aesthetics into film style, glorification of Tokugawa era ethics and deportment, and “sacramental” depictions of the Japanese family system. More specifically:

These films enact a canonization of history, an emphasis on indigenous art forms and design, and a corresponding technical repertoire of long takes and long shots, very slow camera movements, and a highly ceremonial manner of blocking, acting, and set design. The monumental style sets out to transform Japanese traditional from a cultural legacy into a sacrament.⁶⁴

The remediation of Yuan dynasty variety drama (*zaju* 雜劇) through the decidedly modern form of *huaju*, imported from the West, in *Guan Hanqing* seems to likewise match Davis’ description of the cinematic apparatus’ absorption of indigenous Japanese aesthetics. History too was at stake in *Guan Hanqing* and with structures like the Monument to the People’s Heroes, as well as in the debates over how to best imbue new buildings – and new plays, for that matter – with

⁶² Darrell William Davis, *Picturing Japaneseness: Monumental Style, National Identity, Japanese Film* (New York: Columbia University Press, 1996).

⁶³ *Ibid.*, 8–9.

⁶⁴ *Ibid.*, 6.

“national style” parallel Davis’ attention to the ways in which “Japanese identity” is portrayed and shaped through films in the monumental style.

In staging the life of a historical playwright, however, the monumentality of *Guan Hanqing* makes a much more specific and assertive claim for the theater’s authority to memorialize its own history and excavate precedents for Chinese drama. Like many physical monuments, *Guan Hanqing* makes material the symbol of a foundational period in Chinese (theater) history—in fact, the very era during which Chinese drama proper is said to have matured—and pays homage to a foundational figure. Also similar to those figures honored by monuments from times long past, Guan is one for whom the literary record largely exceeds the historical or biographical.⁶⁵ Multiple sources, including the daily journal of Tian Han’s secretary, a letter written by Tian Han to Guo Moruo about the play, and the published proceedings of a conference about the play, make it clear that Tian did his due diligence in consulting the available historical sources, yet also note that circumstances compelled the playwright to take certain creative liberties.⁶⁶ Here, monumental theater’s blurring of the distinction between history and fiction demonstrates the agency of the author, and not only draws on, but also creates the collective memory of a to-be-revered past.

⁶⁵ While theater histories may disagree on the deeper roots of Chinese performance in ritual and court entertainment, there is general consensus that multi-act narrative dramas arose during the Song and Yuan dynasties. The work of playwrights like Guan and the rise of urban, commercial theater during the Yuan mark the first major maturation of dramatic form in the Chinese tradition. See Idema and West, *Chinese Theater, 1100-1450*, 10-94; William Dolby, *A History of Chinese Drama* (London: P. Elek, 1976).

⁶⁶ The conference was co-sponsored by the two leading theater journals, *Xijubao* and *Juben*, and involved several leading scholars and figures in the cultural field, such as Ouyang Shanzun, Zhang Geng, Liu Zhiming 劉之明, Wu Xiaoling 吳曉玲, Zhou Yibai 周貽白, Cai Meibiao 蔡美彪, Shu Xiuwen 舒綉文, Yi Bing 伊兵, Zhang Ying 張穎, Feng Zi 鳳子, and Dai Bufan 戴不凡. “Zuotan Tian Han xinzuo *Guan Hanqing* 座談田漢新作《關漢卿》” *Xijubao* 《戲劇報》 9 (1958): 14-18; Li Zhiyan 黎之彥, “Tian Han chuanguo *Guan Hanqing* ceji 田漢創作《關漢卿》側記,” *Xiju luncong* 《戲劇論叢》 1 (1982): 143-154 (reprinted in *Xiju yanjiu* 《戲劇研究》 9 (1982): 19-31; Guo Moruo 郭沫若, Tian Han 田漢, “Guanyu *Guan Hanqing* de tongxin 關於‘關漢卿’的通信,” *Juben* 《劇本》 5 (1958): 9-11; see also Wei Qixuan 韋啓玄, “Tian Han tongzhi chuanguo *Guan Hanqing* sanji 田漢同志創作‘關漢卿’散記,” *Juben* 《劇本》 5 (May 1958): 34-37.

Theory and Practice of Great Leap Theater: Past Meets Future

Despite its obvious constructedness, the relationship between the play and the past is the dimension of *Guan Hanqing* that has received most attention by contemporaneous commentators and previous scholars alike. Minor scuffles over interpretation of historical evidence was a part of the scholarly discourse mobilized by Guan's 700th anniversary celebration, and Tian Han's staging of largely recordless events in the playwright's life prompted fellow playwrights and theater critics to discuss the appropriate method for writing historical plays suited to the revolutionary present.⁶⁷ Likewise concerned, Rudolph Wagner's detailed study of the play and its composition process outlines an allegorical mode of literary-historical interpretation by detailing the close connections between the play's treatment of Guan Hanqing and Tian's own experience as a writer-intellectual in the Anti-Rightist campaign of 1957.⁶⁸ Wagner convincingly argues that the past depicted by the play functions "as a screen on which to project the pattern of the present" and places it in a lineage of historical plays that includes other prominent works, such as Guo Moruo's *huaju* play *Qu Yuan* 《屈原》 (Qu Yuan, 1942).⁶⁹ While greatly indebted to Wagner's meticulous research, I posit that a reexamination of other essays and dramatic work that Tian Han composed in the months around the publication and performance of *Guan Hanqing* suggests that past and present were not the only temporal dimensions on the

⁶⁷ Of course, this particular discussion and the broader issue of how to retool the "feudal" past was a key part of early 1950s opera reform and extended far beyond the theater. On *Guan Hanqing* in particular, see for example Xia Yan's discussion of "historical plays," in which Xia mostly supports Tian's right to artistic license. Xia Yan 夏衍, "Du *Guan Hanqing* zatan lishiju 讀關漢卿雜談歷史劇 (A Discussion of Various Topics on Historical Plays after Reading Guan Hanqing)," *Juben* 《劇本》 5 (1958): 6.

⁶⁸ Wagner, *The Contemporary Chinese Historical Drama*, 1–79.

⁶⁹ *Ibid.*, 7. See also Wagner's article on Qu Yuan, "The Chinese Writer in His Own Mirror: Writer, State, and Society – the Literary Evidence," in *China's Intellectuals and the State: In Search of a New Relationship*, ed. Merle Goldman, Timothy Cheek, and Carol Lee Hamrin (Cambridge, MA: Council on East Asian Studies, Harvard University, 1987), 183–232.

playwright's mind; he was also caught up in the fervor of the early Great Leap and its visions of a headlong rush into a glorious socialist future.

Indeed, *Guan Hanqing* was born at the precisely the same historical moment as the Ten Great Buildings and the imagined National Theater, when the entire nation was captivated by the Great Leap slogan of “more, faster, better, cheaper” and dedicated to the speedy realization of a socialist utopian future through the efforts of the masses. Studies of the Great Leap tend to focus on the misguided marriage of industry and agriculture that lead to inflation of production statistics, significant waste of resources, severe famine, and loss of life.⁷⁰ What is less often and less seriously discussed is the impact of Great Leap policies on the cultural field, which like agriculture and industry was exhorted to exponentially increased production. Furthermore, according to Chinese drama scholar Colin Mackerras, “modern revolutionary theater” came to be seen as a key tool of ideological promulgation and therefore a chief concern of the state during the Great Leap Forward.⁷¹ Far from balking at such attention, members of the theater community, at least at first, embraced the call to increase production of dramatic works and made concerted efforts to engage the latest Party directives and slogans. At a session of the Capital Drama and Music Creation Conference (Shoudu xiju yinyue chuanguo zuotanhui 首都戏剧，音乐创作座谈会) on March 5, 1958, Tian Han signaled his enthusiasm for the Great Leap by publically announcing that he would participate by composing ten new plays in one year. A month after the conference, in the April 1958 *Juben* 《剧本》 (Play Monthly), Tian published a manifesto that sets several mandates for the development of the theater and praises the ethos of the Great Leap,

⁷⁰ See for example Roderick MacFarquhar, *The Origins of the Cultural Revolution* (New York: Columbia University Press, 1974).

⁷¹ Mackerras, *The Chinese Theatre in Modern Times*, 168.

lists script-production and performance quotas that various city and regional professional performing arts troupes set under the rubric of a “Bitter Toil for Three Years, a Great Leap in Theatrical Creation” (*wei xiju chuanguozuo dayuejin kuzhan san nian* 為戲劇創作大躍進苦戰三年).⁷² The fact that prominent troupes like BPAT pledged hundreds of new scripts, but prior to the Great Leap were averaging ten or fewer major productions per year, demonstrates the extreme to which both quantitative and qualitative theatrical goals were inflated. Rhetorically impressive, Tian’s manifesto would prove as unrealistic as the infamous Great Leap project to smelt steel in backyard furnaces.

At the time, however, such lofty goals were not perceived as a problem. Tian Han himself notes the largely aspirational character of his list with an optimistic tone: “Of the above conditions, some have already been realized, while we are currently striving toward others. We fully believe that these directives can be achieved. ‘More, faster, cheaper’ and ‘better’ are not antithetical, but rather complimentary, and that excellent quality will certainly pour forth from our abundant amount [of production].”⁷³ As if to prove this point, Tian was in the midst of writing and revising *Guan Hanqing* at precisely the moment that his manifesto was published and composed *The Fantasia of the Ming Tombs Reservoir* shortly thereafter. When the play appeared in *Play Monthly* in May 1958, it drew a lively response from readers, and many of the published reviews make reference to *Guan Hanqing* as the first of Tian’s ten promised “Great

⁷² The nine mandates were: (1) to contain a strong political message; (2) to have rich and moving content and themes; (3) to make use of cultural and theatrical heritage; (4) to create theater for the masses, involving the masses, and responding to the ideas of the masses; (5) for artists to visit factories and villages to learn about the everyday life of workers and peasants; (6) to continue the revolutionary mission begun by wartime propaganda troupes; (7) to learn from the artistic experiments of the Soviet Union and other countries; (8) to increase publication opportunities for promising new scripts; (9) to employ new theoretical criticism to help raise the quality of new work. Tian Han 田漢, “Yi gaodu shehui zhuyi ganjin zhengqu xiju chuanguozuo da fengshou 以高度社會主義幹勁爭取戲劇創作大豐,” *Juben* 《劇本》 4 (1958): 2–6.

⁷³ *Ibid.*, 6.

Leap” plays. Thus, like his manifesto and in tune with the general ethos of the Great Leap, Tian’s play also had an aspirational character in that it represented a promise of yet unwritten works to come.

Despite this historical context, however, neither contemporaneous reviews nor later scholarship have attempted to systematically examine the deeper connections between Tian Han’s Great Leap drama theory and playwriting practice, leaving open the question of to what extent his creative work truly absorbed the ethos of the Great Leap Forward. In fact, while the play may not perfectly achieve all of the mandates in Tian’s manifesto, close correlations between the theoretical document and the play do suggest that the latter functioned as testing ground for Tian’s new concept of the ideal drama. First and foremost, the main theme of the play, self-sacrificing use of art as a weapon on behalf of the oppressed, already satisfies several of the more ideological requirements: it contains a revolutionary message, has a rich and moving plot, and depicts artists fighting on behalf of a beleaguered populace. More specifically, we find the requisite “strong political message” clearly articulated when Zhu Lianxiu encourages Guan Hanqing to fight oppression by writing *Injustice to Dou’E*:

Guan Hanqing: When men of old encountered inequality, they would draw their swords to come to aid; I am without a sword to unsheathe, having only a worn-out brush.

Zhu Lianxiu: Is not your brush your sword? Is not theater your sword? In your plays, you have railed against Lord Yang, you’ve railed against Ge Biao, you’ve railed against Lu Zhailang. Everyone who has seen your plays has followed us in detesting those immoral, betrayers of the good, those oppressors of the common man. Why don’t you unmask men like Donkey Li and Hu Xin, and right some wrongs on behalf of unfortunate women?

關漢卿： 古人路見不平，拔刀相助，我是無刀可拔，只有一枝破筆。

朱廉秀： 筆不就是你的刀嗎？雜劇不就是你的刀嗎？你在劇本裏罵過楊衙內，罵過葛彪，罵過魯齋郎，看過戲的都跟著我們一起恨這

些不明道德，陷害良善，魚肉百姓的人。幹嘛不把李驢兒，忽辛這些人的鬼臉給勾出來，替屈死的女子們伸冤呢？⁷⁴

Here, the figuration of Guan's writing brush as a sword directly references Mao Zedong's famous injunction in his "Talks at the Yan'an Forum on Literature and the Arts" (Zai Yan'an wenyi zuotanhui shang de jianghua 在延安文藝座談會的講話, May 1942) that literature and the arts "operate as powerful weapons for uniting and educating the people and for attacking and destroying the enemy, and that they help the people fight the enemy with one heart and one mind."⁷⁵ The clear allusion to the "Talks" accomplishes a dual purpose: it both loudly declares the modern playwright's alignment with orthodox policies on the arts and constructs a precedent for such policies in the history of Chinese theater. Interdependent, past and present derive legitimacy from one another.

The play's focus on a significant historical figure enables it to fulfill additional tenets of Tian's manifesto, namely utilizing native cultural heritage and taking Soviet theater as an instructive model. Seemingly antithetical, these two elements were familiar bedfellows due to simultaneous attempts to "nationalize" (*minzu hua* 民族化) modern arts and to learn from Soviet theater expertise in the mid-late 1950s. Tian Han's particular combination of the two in *Guan Hanqing*, however, can be linked to a more specific personal experience: his trip to Moscow in November 1957 to take part in the 40th Anniversary celebration of the October Revolution.⁷⁶

⁷⁴ My translation from the original publication of *Guan Hanqing*, see Tian Han, *Guan Hanqing*, in *Juben* 《劇本》 5 (1958): 6; English-language translations can be found in the *Columbia Anthology of Modern Chinese Drama*, ed. Xiaomei Chen (New York: Columbia University Press, 2010): 598-673 and in Tian Han, *Kuan Han-Ching, a Play*. (Beijing: Foreign Languages Press, 1961).

⁷⁵ Mao Zedong 毛澤東, "Talks at the Yan'an Forum on Literature and the Arts," in *Selected Works of Mao Tse-tung*, English ed., vol. 3 (Beijing: Foreign Languages Press, 1968), https://www.marxists.org/reference/archive/mao/selected-works/volume-3/mswv3_08.htm.

⁷⁶ Mei Lanfang, Lao She, and Yang Hansheng also participated in this delegation. "Tian Han nianbiao jianbian 田漢年表簡編," in *Tian Han quanji* 《田漢全集》, vol. 20 (Shijiazhuang: Huashan wenyi chubanshe, 2000), 607.

During the 40-day trip, which he specifically references in his manifesto, Tian attended nearly a play per day and was deeply affected by the performances. He discusses his impressions at length in an interview with *Play Monthly* journalist Wei Qixuan 韋啓玄, published in its February 1958 issue.⁷⁷ As recounted to Wei Qixuan, there were certain areas in which Tian felt the Soviet theater to be an especially valuable model: diversity of scripts, representation of Lenin onstage, the use of modern stage capacities, pursuit of and experimentation in artistry, combination of *huaju* with dance and music, close cooperation among playwrights, directors, and actors, adaptation of material from other genres for the stage, and a close relationship between playwrights and “the people.”⁷⁸

Several of these concepts explicitly reappear in Tian Han’s Great Leap Forward manifesto, in addition to the more general call to learn from Soviet theater, but his admiration for Soviet staging of historical figures and the far superior technical capacities of Soviet theaters are most discernable in the text and staging of *Guan Hanqing*. In his discussion with Wei Qixuan, Tian Han describes at length Soviet plays about “the great revolutionary leader Lenin” (*weida geming daoshi Liening* 偉大革命導師列寧) as an important new phenomenon. Whereas earlier plays only featured the leader in brief, cameo-like appearances or as an offstage presence, the productions that Tian Han saw in 1957 made Lenin a main character with a large amount of stage time. Moreover, they largely depicted Lenin closely interacting with ordinary folk, thereby emphasizing the leader’s correct “mental outlook” (*jingshen mianmao* 精神面貌).⁷⁹ These plays

⁷⁷ According to Wei Qixuan, Tian Han originally intended to write several essays on his experiences in Moscow, but did not have time to do so. Tian Han, “Yi gaodu shehui zhuyi ganjin zhengqu xiju chuangzhuo da fengshou,” 5; Tian Han 田漢 and Wei Qixuan 韋啓玄, “Xiang Sulian xiju xuexi: Tian Han tongzhi tan quan Sulian juhuiyan guangan 向蘇聯戲劇學習：田漢同志談全蘇聯劇會演觀感,” *Juben* 《劇本》 2 (1958): 81–85.

⁷⁸ Tian and Wei, “Xiang Sulian xiju xuexi,” 81–85.

⁷⁹ *Ibid.*, 82.

in effect provided Tian with a model for the representation of a “great” political leader, which he then appropriated for the treatment of an equally “great” cultural leader in *Guan Hanqing*. Like Lenin, Guan becomes the protagonist of the play and enjoys by far the most stage time of anyone in its large cast. In addition, by opening the play with the Yuan dynasty playwright stopping for tea and conversation at a common wine shop just outside Khanbaliq (Dadu 大都, or modern day Beijing), Tian Han foregrounds Guan’s correct *jingshen mianmao*. His ease of interaction with Mrs. Liu (Liu daniang 劉大娘), the store’s proprietress, unequivocally demonstrates that Guan finds himself at home among “the people” despite his medical and literary training:

Erniu:	Uncle Guan! Come in for a moment, I’ll make you a cup of tea.
Guan Hanqing:	Thank you! Erniu, you’re getting prettier and prettier. You still remember your Uncle Guan?
Mrs. Liu:	We’re old neighbors! You only moved a little more than two years ago, how could we forget you? Please sit!
Guan Hanqing:	Okay. (Sitting) How’s business?
Mrs. Liu:	Not bad. It’s just that we don’t have enough help, and can’t hire anyone else. My old man is in Wanping most of the time and only comes back once or twice a month.
Guan Hanqing:	That should be alright, Erniu must be a big help!
二妞 :	啊關伯伯來了，進來坐一會兒吧，給您沏壺茶。
關漢卿 :	謝謝，二妞越長越俊了。還記得關伯伯？
劉大娘 :	我們是老鄰居，您搬開這兒才兩年多點兒，怎麼就能忘了呢！坐吧。
關漢卿 :	好。（入座）生意還好嗎？
劉大娘 :	還可以。就是人手不夠，又請不起幫忙的。老頭子在宛平鄉下的時候多，一個月難得回來以兩趟。
關漢卿 :	不要緊，二姑娘又是您一個好幫手了。 ⁸⁰

With this highly colloquial exchange, Tian Han establishes a close relationship between Guan and his former neighbors; his sympathy for the oppressed common folk is only heightened with

⁸⁰ Tian Han, “Guan Hanqing,” 3.

Mrs. Liu tells him the story of Xiaolan, the young woman about to be executed.⁸¹ Later, when Guan is working on the play inspired by Xiaolan's plight, Tian Han depicts him working closely with courtesans and musicians, who would have been among the lowest of social classes at the time. Paradoxically, it is his very humility that suggests a correspondence to significant political figures, such as "the great revolutionary leader Lenin."

Turning to the stage directions and actual staging of *Guan Hanqing* at the Capital Theater, we find the play similarly, if subtly, influenced by Tian Han's Moscow experience, particularly a new-found reverence for the use of "modern staging conditions" (*xiandai wutai tiaojian* 現代舞台條件). In the interview with Wei Qixuan, Tian describes in detail the scenic design of several productions and the flexibility of setting made possible by the large revolving stage of the Soviet Red Army Theater ("Su jun juchang" 蘇軍劇場, now the Central Academic Theater of the Russian Army or Центральный академический театр Российской армии):

The Red Army Theater is the largest theater in Moscow, even larger than our Capital Theater, and its revolving stage is also the largest [in the city]. It can accommodate six interior sets and one vast exterior set. When the curtain opened on *The Reclaimed Wasteland* (Bei kaiken de wainü di 《被開墾的外女地》), there was an endless snowy vista, which later became an endless swath of reclaimed farmland. The revolving stage can be raised and lowered or tilted on an incline, and there was a little bridge, a secluded gully, winding country roads, wooded village cottages, the sounds of dogs and fowl, giving a realistic sense of the countryside. Watching the performance, it was just as if one were personally in the wide Ukrainian countryside.

當“被開墾的外女地”的幕布來起來時，舞台上是一望無邊的雪野，這到後來又成了一望無邊的被開墾的耕地了。舞台上的轉台可以提高，可以放低，還可以傾斜，有小橋，有幽壑，有彎曲漫長的村道，有樹林村舍，雞犬相聞，農村實感很強。看演出時，自己就像置身於烏克蘭遼闊的農村裡一樣。⁸²

⁸¹ Rudolph Wagner also discusses the portrayal of "the people," in relation to the intellectual-writer, throughout his chapter on Tian Han. Wagner, *The Contemporary Chinese Historical Drama*, 1–79.

⁸² Tian and Wei, "Xiang Sulian xiju xuexi," 82.

For Tian Han, as for the architects and technical consultants working on the Tianqiao Theater, the Capital Theater, and the unbuilt 3000-seat theater, the revolving stage held particular significance both as a symbol of theatrical modernization and as a practical enhancement to theatrical production. In this case and in others that he recounted to Wei Qixuan, Tian Han seems to have been most impressed by the ability of the modernized stage to convey a sense of realism. However, he did not view such realism as solely the success of the designer or the production team. Rather, his experiences in Moscow awakened Tian Han to the importance of considering potential staging conditions from the perspective of a playwright. As Wei reports: “After seeing the stage design in Soviet theaters, he [Tian Han] came to feel strongly that the playwright should be very familiar with and have a good grasp of the stage, and should make full use of the modern stage, not close his eyes and blindly write.”⁸³ A nearly identical sentiment is echoed in Tian’s Great Leap manifesto, in which he states: “In the Soviet Union, nearly every theater has a revolving stage, and some revolving stages even have complex lift systems. Some plays become very difficult to perform without a revolving stage, because playwrights create their theater with specific stage conditions in mind.”⁸⁴ In these two statements, Tian Han radically inverts the predominant division between (literary) drama and (performed) theater, and argues for the integration of the writing and staging processes of theater making.

A historical play about a foundational figure in traditional drama may seem an unlikely testing ground for the integration of technology and text, yet aspects of the structure of the play, the script development process, and the staging of its premiere performance all reflect Tian Han’s new concerns. First, on a basic structural level, we find Tian Han’s interest in the

⁸³ Ibid.

⁸⁴ Tian, “Yi gaodu shehui zhuyi ganjin zhengqu xiju chuangzhuo da fengshou,” 5.

potentials of the revolving stage translated into the number of scenes and variety of different settings called for by *Guan Hanqing*. In its first published edition in *Play Monthly*, the play has nine scenes with eight different settings and runs only 27 double-columned pages. From the opening scene, located at Mrs. Liu's street-side wineshop beside the city wall, to courtesan Zhu Lianxiu's home to Guan Hanqing's study to backstage of the performance at Yuxianlou, to the formal hall of the same, to prison, to the Marco Polo Bridge (Lugou qiao 盧溝橋) outside of the city, the play moves quickly and seamlessly between interior and exterior, private and public, commoner and upper class spaces. The numbers of scenes and locations only grows with later editions of the play; productions in June 1958 had ten scenes, while the stand-alone version published that same month increased the number to twelve.

Lest the counting of scene changes seem too facile to be convincing evidence for the influence of modern stage technologies on Tian Han's dramaturgy, we might turn briefly to the play that he composed immediately following *Guan Hanqing*, the propaganda piece *Fantasia of the Ming Tomb Reservoir*. Heralded as the second of Tian Han's promised ten Great Leap plays, *Fantasia of the Ming Tomb Reservoir* dramatizes the experience of a group of contemporary performers, artists, and intellectuals who travel to the construction site of a large dam project in order to find inspiration for their creative work and to entertain the construction workers. Like *Guan Hanqing*, the play can be said to have a commemorative and projective function; it both extols the accomplishments of the innumerable work teams engaged in infrastructural projects and, on a metatheatrical level, depicts artists in the act of writing new works to commemorate one such project. It is even more episodic than *Guan Hanqing*, with 13 brief scenes skipping from location to location as the newcomers visit the sites of various work details, necessitating advanced techniques to shift among diverse exterior settings and across centuries of time, from

the Yuan Dynasty to twenty years following the play's main action. Even more complex are the scene changes within the first scene, which includes two flashbacks to the Yuan and Ming Dynasties that clearly indicate a change of scenery. For example, the stage directions for the first flashback state: "The backdrop returns to the Wenyu River in the Yuan Dynasty (beijing huidao yuandai de Wenyuhe shang 背景回到元代的溫榆河上)."⁸⁵ Later in the scene, another flashback is noted as taking place "during the Ming Dynasty, in the heights of Huangtu Mountain (Huangtushan gao di 黃土山高地)."⁸⁶ Such sudden shifts might be evoked with simple staging, but not in the realist mode mandated by the ideological climate of the time. Meeting the technical challenges of this play thus required innovative improvisation on the part of the China Youth Arts Theater (Zhongguo qingnian yishu juyuan 中國青年藝術劇院), which staged its premiere in July 1958. Lacking a revolving stage, designers and technicians for the Youth Arts Theater invented a "homemade revolving stage" (*tu zhuantai* 土轉台) that created the illusion of moving scenery by simultaneously pulling a curtain backdrop in one direction and pushing large pieces of scenery on casters offstage in the opposite direction.⁸⁷ The effort expended to achieve the effect of a revolving stage suggests both that smooth scene changes were perceived an essential component of the script and that the aesthetic thereby created was desirable to performers and audience.

If we roughly compare the number of scenes and settings in *Guan Hanqing* and *Fantasia of the Ming Tomb Reservoir* to Tian Han's earlier *huaju* works, largely written in the 1920s-

⁸⁵ Tian Han 田漢, "Shisanling shuiku changxiangqu 《十三陵水庫暢想曲》," in *Tian Han quanji* 《田漢全集》, vol. 6 (Shijiazhuang: Huashan wenyi chubanshe, 2000), 228.

⁸⁶ *Ibid.*, 230.

⁸⁷ Zhang Zunji 張傳吉, "Jieshao qingyi chuanguo de tu zhuantai 介紹青藝創造的土轉台," *Xijubao* 《戲劇報》 15 (1958): 35–36.

1930s, we find a striking difference from his former predilection for single-setting one-acts and standard 3-4 act dramas.⁸⁸ The multi-scene drama also stands out in comparison to the works of other prominent playwrights of his generation, such as Cao Yu and Lao She 老舍 (1899-1966), who tended to favor a 3-5 act structure with minimal set changes.⁸⁹ In fact, the episodic nature of *Guan Hanqing* seems more similar to the lengthy *chuanqi* dramas of the late Imperial period or regional opera than to other modern *huaju*. In “traditional” performances genres like Kunqu 昆曲, the burden of creating vivid scenery lies on the skill of the actors and the imagination of the audience. With at most the minimal scenery of “one table, two chairs” (*yi zhuo liang yi* 一桌兩椅) and a few basic hand props, the actors use conventional gestures and poetic lyrics to set the stage. The “impressionistic” or “ideographic” (*xieyi* 寫意) aesthetic that results from such performance practice has been heralded as a defining characteristic of the traditional performing arts. It engenders a drama unencumbered by unities of time, space, and action, and allows smooth temporal and spatial transitions unhindered by the bulk of large set pieces.

In modern Chinese dramatic theory, the native “impressionistic” aesthetic is often set in opposition to the foreign “realist” (*xieshi* 寫實) aesthetic imported via 19th century Western drama and the Stanislavsky system, which dominated *huaju* in the mid-20th century.⁹⁰ However,

⁸⁸ Notable exceptions include several pieces from the 1940s, such as the 21-scene *Lirenxing* 《麗人行》 and the 13-scene *Chaioxian fengyun* 《朝鮮風雲》 (Storm Clouds over North Korea).

⁸⁹ The typical structure for *huaju* in China was based on Western models and largely conformed to Aristotle’s concept of the three unities of action, place, and time. Cao Yu’s plays generally follow this structure closely; Lao She would become more experimental in terms of temporal framework with plays like *Longxugou* 《龍鬚溝》 (Dragon Beard Ditch) and *Chaguan* 《茶館》 (Teahouse), which is fixed in a single location and makes time the main agent of dramatic action.

⁹⁰ The term “impressionistic” or “ideographic” (*xieyi* 寫意) is borrowed from Chinese painting, and was most famously applied to theater in the work of Yu Shangyuan 余上沅 (1897-1970) and Huang Zuolin 黃佐臨 (1906-1994). Various translations into English have been suggested, including Huang’s own various uses of “intrinsicist,” “essentialist,” and “ideographic.” Huang Zuolin, “Fusing of Revolutionary Realism with Revolutionary

working in both *huaju* and opera, Tian Han had a much less binary understanding of the two aesthetic visions. As his secretary, Li Zhiyan 黎之彥, notes:

Comrade Tian Han has said that he has never thought of opera and *huaju* as separate entities. He said that he was first drawn to the theater world by traditional opera, and that he has learned much from it. Scene treatment in traditional opera has greatly influenced him: there are many scenes, the plot develops quickly, the life depicted is very rich, scenes are designed according to the requirements of characters' actions, not solely to have backdrops that dazzle.

田漢統治曾經說過，他從來不把戲曲和話劇截然分開。他說，他主要是由傳統戲曲吸引到戲劇世界裡來的，因而他從傳統的戲曲中得到很多的教益。戲曲中的場景處理方法對他影響很大。戲曲的場子多，劇情發展快，生活面豐富，場景以人物活動的需要而設計，而不是舞台美術的獨立眩耀。⁹¹

Li Zhiyan's comment offers a possible explanation for the dramaturgical shifts of *Guan Hanqing* and his other later works, but considering Tian Han's documented interest in modern stage technologies in the late 1950s, it is a partial explanation at best. Instead, these works show how modern stage technologies made possible a marriage of "impressionism" and "realism"; the ample fly space in theaters like the Capital Theater enabled the playwright to dream of multiple backdrops seamlessly raised and lowered, while the revolving stage and expanded wing space promised fluid movement between pre-set locations. Remediating traditional opera on both narrative and structural levels, Tian Han created works of *huaju* in which the realist translation of a "traditional" structure and aesthetic paradoxically depended upon modern staging devices.

That Tian Han composed *Guan Hanqing* with a modern theater and technical specifications, perhaps even the Capital Theater in particular, in mind finds evidence not only in the structure of the play itself, but also in the playwright's writing and revision process. As Li

Romanticism. (Shanghai People's Art Theatre) (Chinese and Overseas Chinese Theatre)," *TDR (The Drama Review)* 38, no. 2 (1994): 18–28; Ronnie Bai, "Dances with Brecht: Huang Zuolin and His 'Xieyi' Theater," *Comparative Drama* 33, no. 3 (1999): 339–64.

⁹¹ Li Zhiyan 黎之彥, "Tian Han zatan guancha shenghuo he xiju jiqiao: xiju chuanguo mantan zhi yi 田漢雜談觀察生活和戲劇技巧：戲劇創作漫談之一," *Juben* 《劇本》 7 (1959): 39.

Zhiyan recounts in his detailed diary entries from January to June 1958, Tian Han specifically invited directors and actors Jiao Juyin, Ouyang Shanzun, Xia Chun 夏淳 (1918-2009), Diao Guantan 刁光覃 (1915-1992), and Shu Xiuwen 舒綉文 (1915-1969) to participate in a reading of the play's second draft on April 6, 1958.⁹² At the time, these directors and actors were members of BPAT which had exclusive use of the Capital Theater. After the read-through, Tian made adjustments to the script based on their suggestions, including cutting the original first scene and fine tuning the characterization of the play's protagonist to make him more sympathetic. Involving BPAT at such an early stage likely signaled the playwright's intention to have them stage the final product, which they did on June 28th of the same year.

Details of the BPAT premiere of *Guan Hanqing*, designed by Xin Chun 辛純, Song Yin 宋垠, and Yan Xiumin 鄢修民, suggest that the performance at least attempted to realize the playwright's ideal integration of scripting and staging. *Guan Hanqing* was fortunate to have co-directors, Ouyang Shanzun and Jiao Juyin, known for emphasizing design and technical elements in their work.⁹³ First, in what may be read as a direct realist response to the Chinese opera convention of depicting horseback riding with only a whip and set gestures, the production team of *Guan Hanqing* used real horses onstage in the play's opening scene.⁹⁴ Perhaps more

⁹² Colleagues from the Central Drama Academy publication *Xijubao* 《戲劇報》 were also invited. Li Zhiyan, "Tian Han chuanguo Guan Hanqing ceji," 143–54.

⁹³ Incidentally, Ouyang Shanzun also served as the vice troupe director of the 1951 Youth Arts tour to Eastern Europe and the Soviet Union, during which Li Chang and his colleagues surveyed theater architecture and technologies. A summary of Jiao Juyin's rehearsal process for the revival of *Guan Hanqing* in 1963 specifically discusses the director's attention to set, costume, lighting, and sound design; detailed notes from several meetings between Jiao and his set designers, in archives held by the BPAT Museum, likewise confirm the director's deep involvement in the design process. See Jiang Rui 蔣瑞 and Zhang Fan 張帆, "Chong pai Guan Hanqing tishi sanji 重排《關漢卿》提示散記," in *Jiao Juyin wenji* 《焦菊隱文集》, vol. 4 (Beijing: Wenhua yishu chubanshe, 1988), 320–21.

⁹⁴ Unfortunately, as Shanghai-based scenic designer Sun Haoran 孫浩然 noted after seeing the performance, the difficulty of handling live animals onstage proved to be a bit *too* realistic and disrupted the flow of the scene. Sun

successful, and more complex, were the directors and designers' attempts to simultaneously enhance the audience's sense of theatricality and break the fourth wall. A false proscenium built inside the proscenium proper and wooden planks laid over the orchestra pit gave the sense of a traditional three-sided Chinese stage layered over the Capital Theater's more modern performance space; in addition, rather than confining action to either of these two locations, the directors also had actors enter and exit through the house. During the play-within-a-play, in which Zhu Lianxiu performs *Injustice to Dou'E*, Guan Hanqing watched from outside of the proscenium and the actors playing Akham and Horikhoson (Helihuosen 和禮霍森) sat in the first rows of the audience.⁹⁵ One might expect these two moves to contradict one another, but in the case of *Guan Hanqing*, they serve to emphasize an idea already latent within the text, in the relationship between Xiaolan's theatricalized public execution and Guan's dramatization of her story: that the blurring of boundaries between actor and audience, drama and reality serves to highlight the theatricality of everyday life just as much as it roots the theater in the realm of the real. While not all observers approved of these "new staging techniques" (*xin de yanchu shoufa* 新的演出手法), it is at least apparent that the production team was well attuned to the ways in which the particular space of a modern proscenium theater could be manipulated to convey the underlying themes of a given theatrical work.

In addition to these innovations, the BPAT staging of *Guan Hanqing* took advantage of the Capital Theater's revolving stage and (relatively) advanced lighting system. The revolving

was an artistic consultant on the Shanghai People's Art Theater performance of *Guan* and would also go on to design *Guan Hanqing*, sans horses, for a Shanghai Theater Academy (Shanghai xiju xueyuan 上海戲劇學院, or STA) production in October 1959. Sun Haoran 孫浩然, "Guanju zatan 觀劇雜談," *Xijubao* 《戲劇報》 16 (1958): 31.

⁹⁵Detailed description of the staging can be found in articles by Sun Haoran and Ouyang Yuqian. Ibid.; Ouyang Yuqian 歐陽予倩, "Yige chengong de haoxi *Guan Hanqing* 一個成功的好戲《關漢卿》," *Juben* 《劇本》 13 (1958): 25–27.

stage was not used for most of the play's scene changes, but rather reserved for the final moment in which Guan Hanqing and Zhu Lianxiu depart on their voyage into exile. Sun Haoran speculates that this effect was meant to make the actors seem "near yet far" (*zhichi tianya* 咫尺天涯), gradually carrying Guan and Zhu away from the friends who came to see them off, but felt that the result was less than ideal.⁹⁶ Ouyang Yuqian likewise calls attention to the use of the revolving stage in the final moment of the play, with a more forgiving attitude toward the experimental blocking.⁹⁷ Both reviewers also comment on the play's lighting design and attempt to incorporate projection into the piece. For instance, Ouyang describes the eighth scene of the BPAT performance: "During the scene in which Guan Hanqing and Zhu Lianxiu are in prison, the two of them walk side-by-side toward the proscenium opening, while the lights dim behind them. A single spotlight follows them, with the aperture tightened. Like a tracking shot effect in film, this makes the characters stand out and works to strengthen them."⁹⁸ Here, Ouyang's comparison to film highlights another way in which modern technologies were influencing the theater. While there is no indication that playwright, directors, or designers intended to create cinematic effects onstage, their experience working across media – and their audience's growing exposure to film – had begun to create a common vocabulary of visuality that could be invoked even by very theatrical effects.

The production delved even farther into cinematic territory with the design for scene four, during which Guan Hanqing works through the night to compose *Injustice to Dou 'E*.⁹⁹ The

⁹⁶ Sun, "Guanju Zatan," 31.

⁹⁷ Ouyang, "Yige chenggong de haoxi," 27.

⁹⁸ *Ibid.*, 25.

⁹⁹ Notes from design meeting discussions for the BPAT revival of *Guan Hanqing* in 1963, which involved director Jiao Juyin and stage designers Lan Tianye 藍天野, Wang Wenchong 王文冲, and Han Xiyu 韓西宇, provide

opening stage directions are simple, describing the setting as: “Guan Hanqing’s study. On the wall hang a musical instrument and a sword.”¹⁰⁰ Under the light of a single candle, Guan is to pace about in agitation, his gestures the only indication of the emotional turmoil compelling him to put pen to paper. The BPAT performance, however, went above and beyond the stage directions to project the scene of the wronged Xiaolan going to her death onto the back curtain. As Sun Haoran describes it, this moment seems to have achieved an ideal synthesis of script, performer, and design, with the image giving the audience access to Guan’s thoughts and feelings.¹⁰¹ While one might imagine that the intrusion of a different medium and distinct art form detracts from the theatricality of the moment, we find the opposite true in this case. The use of a projection seems to fulfill a function similar to the singing of an aria in traditional Chinese opera or recitation of a monologue in huaju, with image replacing language as the vehicle conveying the character’s inner landscape. Yet, since the image essentially allows the audience to see what Guan sees in his mind’s eye, it paradoxically becomes even less mediated than words used to describe that vision for the audience. Like the later scene in which the audience becomes the “audience” of the *Injustice to Dou’E* play-within-a-play, this constructed affinity between Guan and the audience heightens sympathy for the protagonist and confuses the boundaries between onstage and off. Thus, the use of this technical trick not only fulfills the playwright’s

further evidence that cinematic techniques had become a common part of theatrical design vocabulary. Certain lighting effects are referred to as “shots” (*jingtou* 鏡頭) and, at one point in their talks, Jiao even goes so far as to discuss the pros and cons of mixing film and theater together in performance. Similar records are not available for the 1958 BPAT production. *Daoyan, sheji tan wutai meishu (yi dao shisi)* 《關漢卿》導演，設計談舞臺美術，一到十四 (Guan Hanqing Director and Set Designer Discussions on Scenography), nos. 1-14, February 5, 1963-July 23, 1963 (BPAT Theater Museum Archive).

¹⁰⁰ Tian Han, “Guan Hanqing,” (1958) 8.

¹⁰¹ Sun Haoran states unequivocally that projection was used in the performance: “我們看見關漢卿在燈光下伏案疾書，當他凝想時天幕上映出了朱小蘭屈死的情景。” Sun, “Guanju Zatan,” 31.

vision for more advanced staging techniques, but also does so in a way that directly transmits the inner workings of an ideologically correct revolutionary psyche to spectators.

Agency in Performance: Guan Hanqing Beyond Beijing

Performed in the capital, involving some of the most renowned theater artists of the time, and innovative in certain design elements, the BPAT production of *Guan Hanqing* might have stood as a model for other productions to follow. As noted above, the broader 700th anniversary celebrations certainly seemed to follow a format typified by Beijing, involving a large ceremonial gathering, speeches by political leaders and scholars, productions of pieces by Guan Hanqing, and Tian Han's play.¹⁰² And indeed, taking a production of *Guan Hanqing* by another prominent huaju troupe, the Shanghai People's Art Theater, or SPAT (Shanghai renmin yishu juyuan 上海人民藝術劇院), as an example, we also find certain immediate similarities in production elements like the costuming of Guan and the program design, both of which reproduce Li Hu's famous visualization of the playwright. [Figure 17-18] In addition, SPAT followed its Beijing counterpart in staging a ten-scene version of the play, marking a departure from the original nine-scene version published in *Play Monthly* in May 1958 and the twelve-scene revision independently published by the Drama Press (Zhongguo xiju chubanshe 中國戲劇出版社) a month later. In both cases, the ten-scene version was created through consultation of both published versions.

¹⁰² See note 71.



Figure 17 Diao Guangtan 刁光覃 as Guan Hanqing for the 1958 BPAT production (Source: *Guan Hanqing*, Zhongguo xiju chubanshe, 1960)

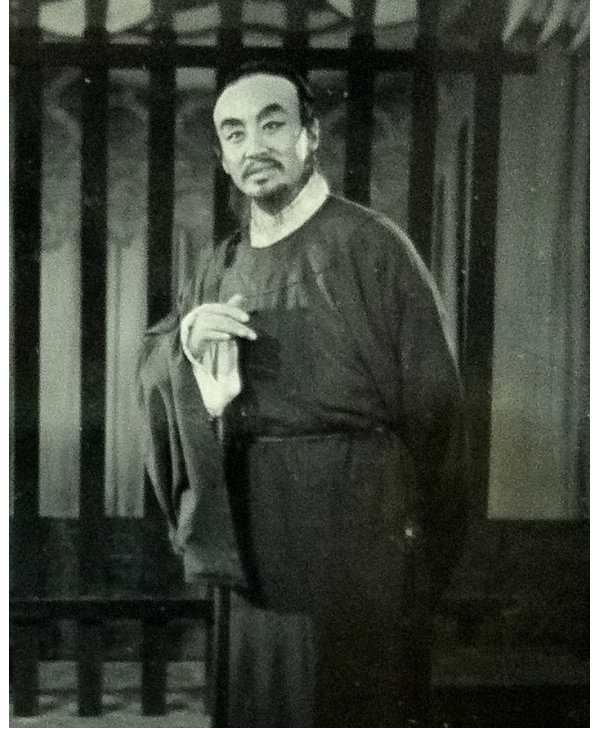

Figure 18 Gao Zhongshi 高重實 as Guan Hanqing for the 1958 SPAT production (Source: Image courtesy of the Shanghai Dramatic Arts Center Archive)

However, a closer look at records from the production process begins to reveal minor discrepancies between the two productions. BPAT, as Ouyang Yuqian notes, began with the longer version and cut it down to ten scenes in rehearsal; the opposite seems to be true of SPAT, which used the *Play Monthly* version as its production script, adding handwritten changes and mimeographed pages of dialogue.¹⁰³ This slight difference rehearsal and revision process seems to have led to a likewise minor difference in the final scene breakdowns, which in the programs

¹⁰³ The production script held by the archive of the Shanghai Dramatic Arts Center (Shanghai huaju yishu zhongxin 上海話劇藝術中心, or SDAC) is an original copy of the May 1958 *Play Monthly* with edits marked and handwritten pages pasted directly on the journal pages. Some minor edits diverge from all published versions of the script and likely indicate adjustments made in rehearsal, but the more substantial additions to the text match the June 1958 version of the play almost word-for-word, suggesting that the later twelve-scene edition was consulted. *Guan Hanqing* production script, SDAC Archive; Ouyang Yuqian, “Yige chengong de haoxi,” 25.

note different locations for Scene IX.¹⁰⁴ The SPAT program describes the scene and setting as “the home of Erniu,” whereas the BPAT program denotes “the office of the Vice Premier of the Imperial Secretariat, Horihokson.”¹⁰⁵ In fact, while both are labeled as Scene IX in the programs, the locations each seem to point to a different scene from the June 1958 edition of the play. An additional line in the BPAT program, which included brief summaries of each scene, confirms that its Scene IX in fact corresponds to the penultimate scene of the twelve-scene version, reading: “Zhou Fuxiang plots to deliver the people’s petition, the assistants cleverly sway the minister.”¹⁰⁶ In contrast, the ninth scene in the SPAT production script depicts a conversation among Mrs. Liu, the wine shop proprietress who relates Xiaolan’s story to Guan in the first scene, her daughter Er’niu, and Er’niu’s husband Zhou Fuxiang 周福祥.¹⁰⁷ In it, the two women convince Zhou, who works as a messenger corresponding with the Mongol rulers’ staff, to deliver a petition of 10,000 signatures asking for clemency on Guan’s behalf to Horihokson. In

¹⁰⁴ While state-sponsored theaters in the PRC generally maintain extensive archives of materials related to past productions, the production script from the original 1958 BPAT production is no longer extant. BPAT published a collection of production scripts in 2012, but the script included for *Guan Hanqing* does not seem to accurately reflect the 1958 production. It contains 11 scenes, whereas the program for the 1958 production held by the BPAT archive lists only 10 in its scene breakdown. This could be due to last minute changes between the printing of the program and the production; however, further proof lies in inclusion of the “tragic” ending in the published production script. Descriptions of the final scene in published accounts prove that the initial BPAT production of the *huaaju* version used a “comedic” ending. After Premiere Zhou Enlai expressed his preference for the “tragic” ending, Tian Han rewrote the ending, but continued to prefer the original. Therefore, a version with the alternate ending cannot possibly be the production script from 1958. For further details on the conflict over the play’s ending, see Tian Han’s own response in his introduction to the English translation, *Kuan Hanqing* (1961), vi-vii; see also Wagner, *The Contemporary Chinese Historical Drama*, 72-76. The published BPAT production script can be found in *Beijing renmin yishu juyuan yanchu juban xuan: 1952-2012* 《北京人民藝術劇院演出劇本選:1952-2012》, vol. 2 (Beijing: Beijing chubanshe, 2012), 267–333.

¹⁰⁵ Performance program for *Guan Hanqing*, June 28, 1958 (SDAC Archive); Performance program for *Guan Hanqing*, June 28, 1958 (BPAT Museum Archive).

¹⁰⁶ “中書省左丞相和禮霍孫的簽押房裏，周福祥計遞萬民稟，徹幕僚巧說和丞相。” Performance program for *Guan Hanqing*, June 28, 1958 (BPAT Museum Archive).

¹⁰⁷ Tian Han, Production Script for *Guan Hanqing*, June 1958 (SDAC Archive).

the full twelve-scene script, this vignette sets up the action that will later take place in the Horihokson's office.

From the perspective of plot development and dramatic structure, neither of these scenes makes much sense on its own, since the action of one follows the situation established by the other. Moreover, adding either one influences the play as a whole: the former emphasizes the role of “the people” in determining Guan's fate, giving agency and voice to a faceless mass of 10,000 supporters through the introduction of their petition to commute Guan's sentence, while the latter both emphasizes the power of the Mongol rulers and tempers their otherwise wholly negative portrayal as “feudal” overlords. The scene featuring Horihokson also includes a significant detail: at the top of the scene, the stage directions instruct Zhou Fuxiang to sneak into the office and move the people's petition from a waste pile to the minister's desk. Later, when Horihokson is discussing the matter with his secretary, an acquaintance of Zhou's who has agreed to lend aid to Guan's cause, he is startled to find that the petition he discarded has mysteriously returned to a pile of important documents –for the third time. His secretary, in the know, hints that Guan might be a descendent of the legendary Guan Yu 關羽 and that there petition's self-locomotion has supernatural causes. As we later learn from the last scene, the trick at least succeeds in sparing Guan the hangman's noose, if not earning him complete amnesty.

The disembodied movement of documents in this scene draws inspiration from the fourth and final act of the very play quoted within the play, Guan Hanqing's *Injustice to Dou'E*. In it, Dou'E, who has already engendered several supernatural events with her unjust execution, returns as a ghost to haunt her biological father, who has passed the official examinations and become an imperial investigator. She draws his attention by weeping and moving her case file to the top of his pile of documents, and later reveals herself to him, thereby ensuring that he will

seek posthumous justice on her behalf. The citation of this particular moment adds another layer to the complex interweaving of theater and real life, actor and audience that is a prominent theme in *Guan Hanqing* and was emphasized in the BPAT treatment of it. On the extra-diegetic level, the 1950s Chinese audience might recognize the citation of another *Injustice to Dou'E* plot point, while on a diegetic level it demonstrates characters borrowing tactics from a recent theatrical piece to influence real life. At work therefore is a conscious citation of the theatrical, making the “real” within the play uncannily, yet purposefully, like the “fictional” play-within-the-play. This completes the circuit of the play’s dramatic structure: Guan is audience to the public performance of Xiaolan’s execution (life has a theatrical element), Guan writes Xiaolan’s story into *Injustice to Dou'E* (theater mirrors real life), and Zhou Fuxiang re-enacts the theatricalized in order to produce a similar result for Guan (life follows a pattern established by the theater).

In contrast, the SPAT version of Scene IX gives more stage time to Mrs. Liu and Er’niu and emphasizes the depth of their relationship with Guan Hanqing. Highlighting the connections between the theater, represented by Guan, and “the people,” embodied in Mrs. Liu and Er’niu, makes a strong statement against the backdrop of Shanghai, a city with a semi-colonialist, capitalist, and therefore ideologically problematic past. The trouble with Shanghai’s urban *shenfen* 身份 (status) resonated in the theater world, which likewise had a troubling past as entertainment and spectacle, on a very material level: the theaters in which the reorganized, now state-sponsored theater troupes performed were largely vestiges of earlier foreign and local commercial ventures. The Yangtze Theater in which *Guan Hanqing* premiered, for example, had a previous life as the Carlton Theater, which largely hosted foreign song-and-dance shows and

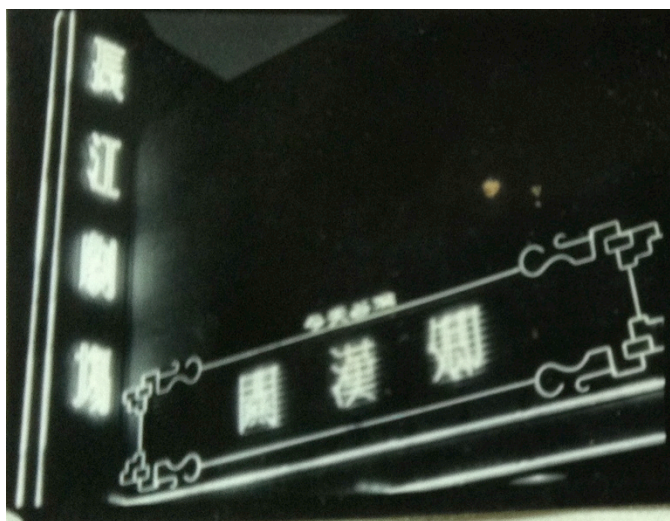

Figure 19 *Guan Hanqing* neon sign, Yangtze Theater, 1958
(Source: Image courtesy of the Shanghai Dramatic Arts Center Archive)

Hollywood films.¹⁰⁸ While renamed and converted to a joint private-state enterprise in 1954, the Yangtze could not completely escape the suspicious ideological allegiances embedded in its material history; even the sight of “Guan Hanqing” in neon lights speaks to an uneasy marriage of past and present. [Figure 19]

The SPAT production of *Guan Hanqing*, in addition to emphasizing “the people,” also highlighted the native dramatic tradition by borrowing basic gestures from operatic acting styles and using backdrops in a “national painting” (*guohua* 國畫) style.¹⁰⁹ A production photo of leading SPAT actress Dan Ni 丹尼 as Zhu Lianxiu, for example, shows her speaking to Sai

¹⁰⁸ Cao Yu’s *Yuanye* 《原野》 (The Wilderness) premiered here in July 1937. *Zhongguo xiquzhi bianji weiyuanhui, Zhongguo xiqu zhi*, Shanghai juan, 643.

¹⁰⁹ *Guohua* refers to a watercolor and ink painting method generally associated with Chinese landscape painting and, like many arts retrospectively labeled “traditional,” was at least partially a modern day invention. For an extensive discussion of painting under the PRC and specifically the role of *guohua* in relation to politics, see Andrews, *Painters and Politics*.



Figure 20 Zhu Lianxiu (played by Dan Ni), *Guan Hanqing*, Shanghai People’s Art Theater, 1958 (Source: Image courtesy of the Shanghai Dramatic Arts Center Archive)

Lianxiu while holding her sleeve, hand in a “lotus flower” position (*lanhuazhi* 蘭花指).¹¹⁰

[Figure 20] From other photos, it is clear that the stage at the Yangtze Theater was quite shallow, with no revolving stage, leaving little room for experimentation with complex sets. The backdrops, in both designers’ rendering and production photographs, are likewise quite simple. [Figures 21-22] In post-performance discussions with other theater troupes, audience members largely had simple words of praise for the sets and lights, although a few comments from stage designers about the limitations of the venue suggest that there may have been some technical difficulties.¹¹¹ Where the BPAT staging innovations were novel but distracting, ever reminding the audience that the traditional aesthetic of the play was being created through the technics of

¹¹⁰ The “lotus flower” hand is the most basic gesture for a female *dan* actress and is common across several different performance genres, including Peking opera and Kunqu.

¹¹¹ “*Guan Hanqing guanhou zuotanhui – san tuan wutai zu* 《關漢卿》觀後座談會——三團舞台組,” n.d. (SDAC Archive).



Figure 21 Production photograph, *Guan Hanqing*, Shanghai People's Art Theater, 1958
(Source: Image courtesy of the Shanghai Dramatic Arts Center Archive)



Figure 22 Set design, *Guan Hanqing*, Shanghai People's Art Theater, 1958 (Source: Image courtesy of the Shanghai Dramatic Arts Center Archive)

the modern realist stage, the SPAT staging privileged the traditional aesthetic more on its own terms, trying to fit *huaju* text and actors to the artistic expectations of opera and visual art. Beyond these two alternate versions of the *Guan Hanqing huaju*, many of the performances of *Guan Hanqing* deviated even farther from the original script(s) to adapt it for operatic genres. The Beijing Municipal No. 4 Peking Opera Troupe (Beijing shi jingju si tuan 北京市京劇四團) and the Shanghai Yueju Theater (Shanghai Yueju yuan 上海越劇院) performed adaptations of *Guan Hanqing* in their respective styles as part of the anniversary celebrations, while a Cantonese opera (*yueju* 粵劇) version performed in 1959 would go on to tour to Beijing and North Korea.¹¹² The significant differences in the performance texts sharing the same name – and the task of commemorating a single historical figure – reveal that artists in the late 1950s retained a certain amount of agency even as the theater universally participated in grand state celebrations. Combined with the possibility of further undocumented alterations, always a chance with live theater, this variation hints at a contingency inherent in the theatrical form that inherently threatens to undermine the use of the theater as a commemorative piece promoting a standard, ideologically correct version of the past. In short, the theater as monument fails to fulfill the fundamental condition of fixity that so vexed Louis Mumford; in theory, its adaptability aligns it instead with the mobility valued by proponents of a new, modern monumentality.

Individual agency and contingency, however, were ultimately at odds with the political agenda of the Chinese communist state. The performance history of *Guan Hanqing* demonstrated this as well when Zhou Enlai, ever interested in the theater, intervened to determine the dramatic

¹¹² “Yueju yuan ganpai ‘Guan Hanqing’: xuduo zhuming yueju yanyuan jiang yongtai yanchu 越劇院趕排‘關漢卿’: 許多著名越劇演員將同台演出,” *Xinmin wanbao* 《新民晚報》, June 21, 1958.

fate of its main character. In adapting the play for Cantonese opera, the Guangdong Cantonese Opera Troupe (Guangdong Yueju yuan 廣東粵劇院) had changed the ending from a “comedic” one, in which Guan Hanqing and Zhu Lianxiu go together into exile, to a “tragic” one in which the two are separated and Guan faces exile alone. According to lead actress Hong Xiannü 紅線女 (1924-2013), who played Zhu in this production, the suggestion for the emendation had originated with Zhou Enlai himself, and Tian Han interpreted this as a necessary ideological realignment of the play, making it more “realist” and giving it a more correct attitude towards “anti-imperialist struggle.”¹¹³ He adjusted the ending for a new printing of the *huaju* script in 1961, but continued to personally prefer his original.¹¹⁴ However, it was the revised version that was used in the BPAT revival of the play in 1963, and the revised Cantonese opera version – the one personally sanctioned by Zhou Enlai – that was made into a film.¹¹⁵ Made disseminable and infinitely reproducible but unchangeable, this is the only recording of play from the 1950s-1960s that survives today, entombed by the cinematic apparatus.

Modeling the Modern World: Performing the Socialist Utopian Future

From the fate of *Guan Hanqing*, we can see the trends towards intervention and standardization that were already in motion with the nationwide practice of commemorative performance that became a key part of the PRC cultural program in the 1950s and which would culminate in “eight hundred million people watching eight model operas for eight years” (*ba ge*

¹¹³ Li Zhiyan, “Tian Han chuanguo *Guan Hanqing* ceji,” 143-154.

¹¹⁴ Tian discusses the revisions in his introductions to the 1961 edition and an English translation published by Foreign Language Press the same year. Wagner analyzes the politics of Zhou’s intervention and Tian’s response at length in his chapter on *Guan Hanqing*. Wagner, *Contemporary Chinese Historical Drama*, 72-76.

¹¹⁵ *Guan Hanqing* 《關漢卿》(1960; Guangzhou: Guangzhou jiaojiaren wenhua chuanbo gongsi, 1997), VCD.

yangbanxi bei ba yi ren kanle ba nian 八個樣板戲被八億人看了八年) during the Cultural Revolution. The determination and dissemination of a single, officially sanctioned version of a live performance through film, presaged by the recording of the “tragic” version of *Guan Hanqing*, would be employed for each of the eight model operas. Even live performances would be reduced to a kind of embodied mechanical reproducibility, with detailed manuals for blocking, lighting and sound cues, costumes, make up, sets, and props circulating and dictating production details down to the smallest technical elements. The Cultural Revolution was furthermore a period that would be described in retrospect as highly theatrical, as participants and observers would adopt the discourse of the theater in attempts to explain the sublime and surreal experience of having been both a willing actor and manipulated puppet in a grand drama of national destruction.¹¹⁶

Even this seems foreshadowed by *Guan Hanqing*, which in its premiere performance by BPAT achieved a blurring between actor and audience through technical tricks and creative use of the playing space. Such blurring of roles was moreover a theme latent within the play itself; Guan Hanqing, who plays audience to the execution of Xiaolan in the first scene, is later revealed to occasionally “tread the boards” himself. While he does not act in the play-within-a-play performance of *Injustice to Dou’E*, Tian Han makes certain that the audience knows Guan has the skills to do so if necessary.¹¹⁷ Moreover, the general theatricality of the opening scene, which depicts the show-trial like execution of Zhu Xiaolan on the streets of Yuan Dynasty Beijing, signals from the outset that the characters in the world of the too often are spectator and

¹¹⁶ Ban Wang, *The Sublime Figure of History: Aesthetics and Politics in Twentieth-Century China* (Stanford, CA: Stanford University Press, 1997).

¹¹⁷ The discussion in which Guan reveals that he occasionally performs was added for the play’s second publication in June 1958 (and occurs in a scene that was not cut from the BPAT performance). Tian Han 田漢, *Guan Hanqing* 《關漢卿》 (Beijing: Zhongguo xiju chubanshe, 1958), 19.

spectacle at the mercy of a corrupt justice system. If we take into consideration the fact that Tian Han's original draft of the script included an additional prologue scene, to precede Xiaolan's execution, the picture becomes all the more nuanced. As Wagner details in his chapter on *Guan Hanqing*, Tian Han's first draft (March 31, 1958) included a metatheatrical frame in which actors played spectators on stage gathered for a performance of *Injustice To Dou'E*, but the curtain opens on *Guan Hanqing*.¹¹⁸ This metatheatrical frame suggests two things: a purposeful blurring of actor and audience – making the common spectator aware of his or her role as an actor – and an initial confusion of the otherwise distinct play proper (*Guan Hanqing*) and play-within-a-play (*Injustice to Dou'E*). Tian Han cut this scene after the first read-through of the script, but its initial inclusion nonetheless reveals something of the importance of the blurring of actor and audience to the playwright and the play.

This blurring takes on new resonance in its historical context given that when Tian Han wrote this play, hundreds of thousands of workers, peasants, and soldiers were finding themselves taking on the role of actor in neighborhood and work unit “cultural troupes” (*wengongtuan* 文工團). The widespread promotion of amateur cultural production and the amateurization of intellectual and professional fields, like writing, music, and theater, can be traced to the cultural policy proceeding from Mao's “Talks at the Yan'an Forum on Literature and the Arts.”¹¹⁹ Scholars such as D.W. Fokkema, Colin Mackerras, and Bonnie McDougall

¹¹⁸ Wagner translates and analyzes an account of the draft written by Li Zhiyan in his notes on the composition of *Guan Hanqing*. Wagner, *Contemporary Chinese Historical Drama*, 11.

¹¹⁹ The need for transmission of professional knowledge can also be seen from the run of publication of “how-to” manuals sponsored by both provincial and arts presses during the early-mid 1950s. A series entitled *Wenyi huodong xiao congshu* 《文藝活動小叢書》 (The Literary and Arts Activities Collection) published by Liaoning People's Press (Liaoning renmin chubanshe 遼寧人民出版社) in 1956, for example, includes a total of twelve volumes with titles like: *Zenyang paixi he yanxi* 《怎樣排戲和演戲》 (How to Rehearse and Perform Plays), *Zenyang huazhuang* 《怎樣化妝》 (How to Put on Makeup), and *Wutai meishu rumen* 《舞台美術入門》 (Introduction to Stage Design). Other titles even more directly address the plight of the amateur, such as *Yeyu jutuan yanxi changshi wenda*

have discussed these trends, with McDougall and Mackerras focuses more specifically on dramatic literature and performance. As Mackerras's article on "Amateur Theater in China, 1949-1966" notes, government support for amateur theater activity had its high and low points during the 1950s.¹²⁰ Far beyond the yearly mass participation in events like National Day parades, the beginning of the Great Leap Forward brought a period of particularly intense focus on mass *production* of literature and the arts, with theater was one area of particularly high activity.¹²¹ Even Tian Han's Great Leap manifesto includes as a key point that professionals could not shoulder the burden of a great leap in artistic creation alone, thus the participation of the masses and cooperation between professionals and amateurs was necessary.

The actual implementation of measures promoted by Tian Han and other high level cultural figures like Zhou Yang, whom Tian Han quotes frequently in his manifesto, can be seen from essays that summarize the experiences of on-the-ground professional culture workers, which confirm the necessity of involving non-professionals like workers in order to meet their

《業餘劇團演戲嘗試問答》(Basic Questions and Answers for Amateur Theater Troupes), published by Jiangsu People's Press (Jiangsu renmin chubanshe 江蘇人民出版社) in 1955. In addition, beginning in 1956, the professional periodical *Play Monthly* began to issue a "rural edition" (*nongcunban* 農村版) that, with one name change to *Xiao Juban* 《小劇本》(Ancillary Play Monthly) in June 1958, continued publication until the Cultural Revolution.

¹²⁰ For example, in December of that same year, two articles in *People's Daily* reported the launching of government-backed initiatives in Liaoning and Heilongjiang, respectively. Describing the situation in the Lüda Region (Lüda diqu 旅大地區, also known as Lüshunkou 旅順口), the article claims that individual cities and counties boasted upwards of 100 local theater troupes each. Similarly, in Heilongjiang, the Provincial Propaganda Department issued a directive ordering the Rural Literature and Arts Troupe to foster activities that would promote "self-writing, self-directing, self-acting, and the development of literary and artistic creative work among the masses." 《旅大地區各市縣區村普建群眾文化組織，大批業餘劇團展開活動》 *Renmin ribao* (December 12, 1949), 3 (online database); 《中共黨黑龍江省委宣傳部指示：發展農村業餘劇團，文工團利用冬閒下鄉協助》 *Renmin ribao* (December 13, 1949), 3 (online database); Colin Mackerras, *Amateur Theatre in China 1949-1966*, Contemporary China Papers, No. 5 (Canberra, Australian National University Press, 1973).

¹²¹ For detailed description and analysis of mass spectacle during the first decade of the PRC, see Chang-Tai Hung, "Mao's Parades: State Spectacles in China in the 1950s" 190 (2007): 411–31. A revised version of this article, as well as a discussion of the Ten Great Buildings, is included in Hung's recent monograph, *Mao's New World: Political Culture in the Early People's Republic* (Ithaca, NY: Cornell University Press, 2011).

script and performance quotas. The Shanghai People's Art Theater, for example, reports a 262% increase in the number of performances given in 1958, compared to 1957, and claims that a full third of these were performed by workers, peasants, and soldiers.¹²² Similarly, Mackerras quotes a *People's Daily* report of 283,000 amateur and worker drama troupes nationwide in 1959 (compared with 3513 professional troupes) and *Drama Monthly* reported 14,000 amateur troupes comprised of 400,000 actors in Heilongjiang province during that same year.¹²³ As Mackerras notes, there is reason to doubt the veracity of these numbers, but even if dramatically inflated, the fact of their publication suggests that there were at least attempts to promote amateur theater and, as with theater buildings in the First Five Year Plan, that quantitative increase was of importance to Party leadership. On the other hand, given the difficulty of accurately calculate the true number of workers and peasants engaged in everyday dramatic activity, it is perhaps also possible that these seemingly inflated statistics are actually under-reporting the extent to which amateur theater had permeated Chinese society by the end of the 1950s. More than ever before, the common people extolled in Chinese communist ideology were becoming not just workers, peasants, and soldiers, but actors and playwrights.

Thus, in performing an idealized past for Chinese theater, *Guan Hanqing* is providing an idealized past of relevance to all of its audience members. What I want to propose here is that the sustained growth of amateur theater during the Seventeen Years period (1949-1966), the increased participation of non-professionals in theater activity, and the importance of the didactic link between professionals and non-professionals allows us to posit a re-reading of *Guan*

¹²² Since the dating in this article is unclear, I am not sure if this refers to plays already performed by the time the article was published in November 1958 or if it is a target number to be performed by the end of the year. *Xiju Gongzuo yuejin jingyan xuanji* 《戲劇工作越近經驗選輯》, vol. 1 (Shanghai: Shanghai wenyi chubanshe, 1958), Duxiu database.

¹²³ Mackerras, *Amateur Theatre in China 1949-1966*, 10.

Hanqing as a model for theater troupes from which any actor, professional or amateur, could learn and draw inspiration. Like many literary works of socialist realism and propaganda plays, both *Guan Hanqing* its actors as clear heroes with ideologically correct social consciences. The social organization within the play seems prescient of the theory of the Three Prominences (*santuchu* 三突出) that would become a guiding force of composition and performing during the Cultural Revolution: to make prominent, in increasing hierarchical order, positive characters, heroic characters, and the main heroic characters.¹²⁴ Guan's coterie of literary and theater friends form the circle of positive characters, with Guan and Zhu Lianxiu emerging as the ones who dare to use their art as a weapon against oppression and corruption. Guan, as demonstrated above, exhibits the most important characteristic of the model artist, and model member of society: a commitment to the responding to the needs of the people. Also, rather unsurprisingly, the play promotes collective living and a collaborative creative spirit as central to the success of the theater troupe. In *Guan Hanqing*, Guan may be the most prominent hero, but his work could not be accomplished without the solidarity of his companions. He only dares to write *Injustice to Dou'E* after Zhu Lianxiu encourages him and promises to perform it (Scene II), the play is perfected through suggestions from other actors and musicians (Scene V), and his imprisonment ultimately comes about when he refuses to abandon his acting troupe to be punished for refusing to change the lines and lyrics that he wrote (Scene VII).

The fact that the values embodied through Guan Hanqing and his cohort are not theater-specific values, but rather general values, turns the tables in the opposite directions and suggests

¹²⁴ This theory was developed by Yao Wenyuan (1969). For discussion of the Three Prominences in model opera, see Ellen Judd, "Prescriptive Dramatic Theory of the Cultural Revolution," in *Drama in the People's Republic of China*, ed. Constantine Tung and Colin Mackerras (Albany: State University of New York Press, 1987), 94–118; Yomi Braester, *Witness against History: Literature, Film, and Public Discourse in Twentieth-Century China* (Stanford, Calif: Stanford University Press, 2003), 112–114; Paul Clark, *The Chinese Cultural Revolution: A History* (Cambridge ; New York: Cambridge University Press, 2008).

that the play is not only a how-to guide for aspiring actor-audiences, but also a more general metaphor for social interaction. That is to say, if everyman is an actor, then to some extent, plays about actors might also be plays about everyman. Heroic behavior encourages the common man to be heroic, and the model cooperation of the theater troupe suggests the proper behavior for all manner of collectives. It is moreover a model that is inherently theatrical. It is this awareness of the theatricality of the self—the theatricality of one’s own social role—as well as its more obvious use of the play-within-a-play construct that brings *Guan Hanqing* close to Lionel Abel’s seminal definition of the metaplay. In Abel’s idiosyncratic essay collection, he defines metatheater as involving characters that are aware of their own theatricality and reflecting a world that is already theatricalized.¹²⁵ Metatheatricality is therefore descriptive and self-reflective. *Guan Hanqing* echoes this, but if we read the play as having a didactic, “how-to” function, it becomes as much projection for the *future* as a comment on the past. Less a reflection of existing social relationships, it more models a future perfect world in which professionals and amateurs, actors and masses are one, and a world in which daily life will become theatricalized.

Although unique in its complex metatheatricality, Tian Han’s play is far from the only one from the early PRC to be future-oriented. Even before the Great Leap Forward, the theater was used to stage visions of the world as it would become under the great leadership of the Party. Yomi Braester’s work on the drama and film versions of Lao She’s *Dragon Beard Ditch*, for example, describes the close relationship between the play and Beijing city planning during the

¹²⁵ For example, Abel argues of *Hamlet* that the play provides a protagonist already aware of what it means to be staged, or of Beckett that his plays respond to a bleak world that is already far descended into the realm of theatricality. Lionel Abel, *Tragedy and Metatheatre: Essays on Dramatic Form* (New York: Holmes & Meier, 2003), 132, 158.

early-mid 1950s.¹²⁶ Braester shows how the play (and its film version) depicts the success of a large public works project that, at the time of the play's premiere, had not yet been completed. Set in a traditional courtyard in Beijing, what is at stake in Lao She's play is "not so much recording the past as laying out a future program for the popular perception of urban policy."¹²⁷ Braester discusses the "creative chronology" employed by the play, which amends and leaves out historical details just as *Guan Hanqing* liberally fills in the gaps left by missing records, and coins the term "prescriptive chronotope" to describe the way in which the play links the material, social, and ideological futures of the urban landscape, arguing that: "In addition to speaking in the name of the people, the play claims to recover suppressed voices, tells in public the bitterness of oppression, identifies the people's enemies, dramatizes a dialectic between doubters and enthusiasts of the Revolution, and projects a future in which socialism will have fully materialized."¹²⁸ Here, there is a similarity to the modeling of interaction among the theater troupe members in *Guan Hanqing*, with the key difference that the values modeled by *Guan* are suggested to be universal, ideologically correct and unchanging across past, present, and future.

These plays, along with the many, far less subtle socialist utopian plays written during the Great Leap Forward, signal a major shift in the role of the theater in the early PRC.¹²⁹ More than propaganda, the theater became an important tool for providing models and road maps for a very specific, idealized vision of the Chinese Communist future, a goal that would be most fully

¹²⁶ Braester prefers the translation of "Dragon Whisker Creek," but here I use the more common English translation of the title, "Dragon Beard Ditch." Yomi Braester, *Painting the City Red: Chinese Cinema and the Urban Contract*, Asia-Pacific (Durham NC: Duke University Press, 2010), 27–55.

¹²⁷ *Ibid.*, 41.

¹²⁸ *Ibid.*, 38.

¹²⁹ For a discussion of other plays from the Great Leap Forward era that explore visions of a Chinese socialist utopia, see Shen Yan 申燕, "'Da yuejin' yu shehui zhuyi qutuobang xiju '大躍進'與社會主義烏托邦戲劇," *Wenyi yanjiu* 《文藝研究》 8 (2013): 95–102.

realized in *Dongfang hong* 《東方紅》 (The East is Red), a massive “song-and-dance epic” (*yinyue wudao shishi* 音樂舞蹈史詩) staged in the Great Hall of the People in honor of the 15th Anniversary of the founding of the PRC in 1964 and, soon thereafter, in the Cultural Revolution model operas. Rather than displaying a “nostalgia for the future,” which Braester identifies in *Dragon Beard Ditch*, these plays celebrate, commemorate, and model the future, serving as monuments to a socialist utopia whose future existence was guaranteed by Marxist teleology. What Tian Han’s work adds, and what is present in spectacles like *The East is Red* and the model operas, is the undeniable theatricality of that future.

It is precisely this quality that is constructed more explicitly in what we are coming to see as a companion piece to *Guan Hanqing, Fantasia of the Ming Tomb Reservoir*. In the play’s concluding scene, Tian Han transports his characters, and the audience, to the already realized socialist utopia of China twenty years hence. It is a future filled with fantastic technologies, including private heliopads for airship landings and handheld electronic communication devices.¹³⁰ According to Tian Han’s stage directions, it is also an era in which:

Young men and women wear clothes that are more rational and more beautiful, but also fit the national style. Twenty years ago, one of our leader comrades said: in the future, when we achieve a communist society, maybe we Chinese will wear the beautiful costumes of the stage; here we can observe this trend, but it’s important that function and rationality are taken care of and that we don’t mechanically copy ancient costumes.

青年男女穿著更合理，更美觀又富餘民族風格的服裝。二十年前有些領導同志說：將來到了共產主義社會，也許中國人都穿著戲台上美麗的古裝，從這裏也可以看到這種傾向，但又主要照顧著實用和合理，並非古典服裝的無原則的硬搬。¹³¹

¹³⁰ In the film version of the play, for instance, one of the characters places a video call to her parents using a device that looks like an electronic dictionary from the early 21st century. The film was reissued on DVD in 2005. Jin Shan 金山 et al., *Shisanling shuiku changxiangqu* 十三陵水库畅想曲 (Beijing/Guangzhou: Zhongying yingxiang chuabnshe, 2005).

¹³¹ Tian Han, *Shisanling shuiku changxiangqu*, 309.

One could speculate endlessly as to which “leader comrade” Tian Han refers here to shield himself from accusations of revivalism; more relevant is the fact that Tian Han has imagined, alongside the typical trappings of science fiction, a distinctly theatrical element in his future world. An aesthetic rooted in the costumes of the traditional Chinese stage preserves national style amidst technical advancement, just as *Guan Hanqing* stages an historical drama under the aegis of the Great Leap Forward and with (some) experimentation with staging technologies. At the same time, it echoed the idea that everyman could be an actor. As here staged, therefore, the past is a theatrical past and the future none other than a theatrical future. And if the theater is a monument, it is one that commemorates equally an idealized past and a utopian future.

Conclusion

During the 1950s, state support for technical modernization *in* the theater began to be replaced by a more mechanical appropriation *of* the theater as a tool for ideological promulgation; artistic agency and the contingency of performance would be subjected to ever more strident regulations and ideological mandates. But the first seventeen years of the PRC were also a time of aspiration and imagination. From designers like Li Chang to playwrights like Tian Han, theater artists of the 1950s developed concepts of what the ideal, modernized theater spaces of the present and the ideal theater worlds of the past (and future) should be, and worked to bring them into being. The monumental and commemorative impulses at work in much of the construction and creative work during this period sounded uneasily against the backdrop of a state and society still in the process of formation, but nonetheless generated complex works of art, like Tian Han’s *Guan Hanqing* and *Fantasia of the Ming Tombs Reservoir*. By excavating and unpacking the different dimensions of one play’s performance history—its multiple versions,

relationship with Tian Han's own evolving concepts of dramaturgy and staging, its connection to broader shifts in performance culture—we find a work capable of foreshadowing both the technologization of the theater and its capacity for resistance thereof.

Interlude

Performance as Technology: Technical Execution in Cultural Revolution Theater

In her discussion of the Cultural Revolution model ballet *Hongse niangzijun* 《紅色娘子軍》 (*The Red Detachment of Women*), Kristine Harris calls particular attention to a section of the performance marked in the script as a “*guo chang* 過場,” or interlude—literally, to cross the stage. The interlude comes between the penultimate and final acts, and features soldiers dancing in formation on a bare stage, red flag waving high. They conclude with a line of *grand jeté* across the stage, “like arrows flying forth from a bow, pressing forward with indomitable will.”¹ Photographic images of the latter sequence recall, for Harris, the stop-motion photography of Eadweard Muybridge and the ability of the camera to freeze its subjects in a moment between motions, in a way that only further emphasizes action and speed.² Unlike the photographic still, however, there is no pause in action in the film version, and instead what catches the eye is the pure theatricality of the moment. In other scenes, there are attempts at three-dimensional set pieces and painted backdrops that, while hardly photorealistic, indicate concrete locations: a courtyard, a forest, a rocky outcrop. Here, there is a bare stage backed by a cyclorama (cyc), onto which is projected a turbulent, cloudy sky. When the camera cuts to the *grand jeté* sequence, the dancers are suddenly leaping across rockier ground—less clearly a stage, but with the same stormy special effects in the background. Their synchronized movement highlights the technical

¹ Original text: “如離弦之箭，一往無前。” Zhongguo wuju tuan 中國舞劇團, *Geming xiandai wuju Hongse Niangzi Jun* 《革命現代舞劇紅色娘子軍》 (Beijing: Renmin chubanshe, 1970), 56–57.

² Kristine Harris, “Re-makes/Re-Models: The Red Detachment of Women between Stage and Screen,” *The Opera Quarterly* 26, no. 2–3 (2010): 337, doi:10.1093/oq/kbq015.

perfection of the dancing body, perfectly framed with lighting, sound, and set. Moreover, while this scene may foreground the speed and action of the dancers, it does little to further the dramatic action of the dance-drama's narrative. Presumably, the soldiers are on their way between the battles that take place in the Acts proper, or perhaps even in battle, but there are no enemies present. The interlude therefore seems to take place both out of place and out of time, an extra-diegetic display of the well-trained dancing body.

This brief chapter is itself an interlude that will take up the tensions of technical execution in stage productions of the model operas (*yangbanxi* 样板戲). It constitutes a pause between the main acts of the dissertation and an inflection point in its argument. Thus far, I have demonstrated how theatrical lighting came to the fore in the 1930s, influencing both revolutionary applications of the theater and attempts at modern dramaturgy in the *huaju* genre. I have also shown how stage construction became a key element of state building in the early years of the People's Republic of China, and how the architectural elements of modern theaters became both important symbols of political power and inspirations for new experiments in playwriting and staging. At the same time, both theater construction and play production became increasingly governed by the imperatives of socialist production—with performing artists refigured as cultural workers, the theater became a kind of factory for churning out impossible numbers of scripts and performances. Both cases reveal that the technical elements of the theater—lighting equipment, revolving stages, the manuals that describe them—have contributed to the appropriation of the theater by political forces. That is to say, the technologies of the theater contribute to the instrumentalization of the theater as a technology of politics. In the 1930s, the political forces were radical Leftist revolutionaries. In the 1950s, they were largely the artists, but now on the payroll of state-sponsored theater institutions. In the 1960s, those

implicated in this process include not only theater professionals, but all members of Chinese society, from all walks of life.

The *yangbanxi* represent a limit case of what I am calling the “technologization” of the theater. These works lay at an extreme end of my argument, both in the obsessive attention to the perfection of technical detail within the works, and in the extent to which they served as instruments of politics. In what follows, I will use published *yangbanxi* production manuals and their film versions to argue that these productions represent an ideal theatrical form defined by the flawless execution of technical details on all levels of performance, but that in requiring such virtuosity, the *yangbanxi* forestalled their own realization. It is this characteristic, more than their idealized representations of revolutionary heroes, that makes them a truly utopian form.

As an officially designated *yangbanxi*, *The Red Detachment of Women* was one of the few stage works sanctioned for production during the chaotic ten years of the Great Proletarian Cultural Revolution (*wenhua da geming* 文化大革命), from 1966-1976.³ The *yangbanxi* were promulgated beginning in May 1967 and initially included five “modern revolutionary *jingju*” (*xiandai geming jingju* 現代革命京劇), two ballets, and an orchestral piece.⁴ All of the pieces were based on revolutionary history, and all promoted idealized revolutionary heroes. However, the *yangbanxi* functioned as much more than representations of history and heroics. As the

³ The term *yangbanxi* is most commonly translated as “model operas,” so I adopt that terminology here, but will refer to the performances as *yangbanxi* throughout the chapter. As many scholars have correctly noted, the use of “opera” to translate terms like *yangbanxi* as “model opera,” *xiqu* as “Chinese opera,” or *jingju* as “Peking opera” suggests a closer parallel to Western opera than exists and problematically subjects native Chinese forms to an unnecessary Westernization.

⁴ As Paul Clark and other Cultural Revolution scholars have noted, all of the *yangbanxi* were based on preexisting literary and theatrical works, and their development into “model works” actually began years before their official designation in 1967. Clark, *The Chinese Cultural Revolution*, 16–18.

popular slogans of “acting a revolutionary character in order to become a revolutionary person” and “watching revolutionary model play in order to become a revolutionary man or woman” make clear, the *yangbanxi* were meant to produce a nation full of *yangban* citizens through audience identification with model heroes and actual participation in amateur productions.⁵ The government encouraged widespread performance and adaptation, and later invested in film versions as a way to ensure that the *yangbanxi* and their ideological message reached every corner of the nation.

As the official artistic works of the Cultural Revolution, the *yangbanxi* cannot escape their association with the infamous decade of turmoil, persecution, and near civil war. The fact that Jiang Qing 江青 (1914-1991), who would later be denounced as one of the main perpetrators of the Cultural Revolution, directly involved herself in the development, production, and filming of the *yangbanxi* contributed to their reception in the post-Mao era. For years, Chinese scholars decried the cultural production of the period as evidence of excessive, misguided political control of the arts and devoid of any value. In the last decade, however, there has been a surge of scholarly interest in the Cultural Revolution and, in particular, in the material, visual, and performance culture of the period. Scholars such as Paul C. Clark, Yomi Braester, Xiaomei Chen, and Barbara Mittler have demonstrated both that works of propaganda, like the *yangbanxi*, work in ways much more complex than previously understood and that grassroots culture of the period was far more varied than the oft-quoted slogan of “eight hundred million people watching eight model operas” suggests. Even Chinese scholarship, while historically critical of the aesthetic uniformity of the *yangbanxi*, now admits that they achieved some formal and technical

⁵ Chen, *Acting the Right Part*, 19.

advances.⁶

In scholarly analysis of *yangbanxi* films, much attention has been paid to how the apparatus of the camera was used to reinforce the ideological messages and identification process that were the core of the *yangbanxi*. The mandates of the central dramatic theory of the Cultural Revolution, the “Three Prominences” (see Chapter 2), were put into cinematic practice by framing the primary heroes with close-up, low-angle shots and visually relegating villains to marginal, poorly lit screen spaces.⁷ In accordance with the theory, all other elements of the film—everything that appeared onscreen—were also carefully composed in order to underscore the revolutionary plot and contribute to the proper characterization of heroes and villains. Published records of Jiang Qing’s critiques of the *yangbanxi* and memoirs detailing her incessant intervention in film production have given us a detailed window onto the world in which a single critic could demand a film be re-shot multiple times. In several oft-cited episodes, Jiang Qing also mandated very specific colors for costumes and scenery. For instance, as Laikwan Pang details in an article on color in the films, in one meeting during the filming of *Haigang* 《海港》 (On the Docks), Jiang Qing told the creative team:

The scarf [of the character Gao Zhiyang] could be changed into beige color – all you know is white. Now the anchor is red, and the seawater is blue. There is no mediating color in between, so that [the red and the blue] cannot be harmonized.⁸

⁶ See for example Zhang Lian 張連, ed., *Zhongguo xiqu wutai meishu shilun* 《中國戲曲舞台美術史論》 (Beijing: Wenhua yishu chubanshe, 2000), 212–215.

⁷ See Chapter 3 note 142.

⁸ Translated by Laikwan Pang. Apparently, Jiang Qing also knew quite a lot about film stock and processing. Pang cites Jiang Qing 江青 “Zhongyang shouzhang jiejian dianying, xiju, yinyue gongzuozhe zuotanhui 中央首長接見電影，戲劇，音樂工作者座談會,” January 1, 1973. Laikwan Pang, “Colour and Utopia: The Filmic Portrayal of Harvest in Late Cultural Revolution Narrative Films,” *Journal of Chinese Cinemas* 6, no. 3 (2012): 273.

Chris Berry has also argued for the importance of colors in the *yangbanxi* films, claiming that they “need to be understood as forces rather than meanings, and that as forces they coordinate with cutting, framing, music, lighting and other elements to create patterns of embodied engagement for the spectator.”⁹ In both cases, technical details are deployed on behalf of the intended message of the film; in contrast, Paul Clark approached technical details from another angle. In his seminal work *The Chinese Cultural Revolution: A History*, he argues that examining the technical part of the film industry—in particular, the importance placed on the domestic production of color film stock and the training of specialists in film lighting and sound—reveal a different picture than typical accounts of the Cultural Revolution, which tend to emphasize the stagnation of the film industry during the decade.¹⁰ On multiple levels, then, the technical details of cinema have been recognized as significant to the ideological functions of the *yangbanxi* films and to our retrospective understanding of them as both political-aesthetic objects and part of cultural history.

When it comes to the stage versions of the *yangbanxi*, scholars have similarly noted the importance of light and color. For example, Kirk Denton, in his semiotic analysis of *Zhiqu weihu shan* 《智取威虎山》 (Taking Tiger Mountain by Strategy), comments on the use of light and shadow for the positive and negative characters and on the symbolism of costume colors.¹¹ Yomi Braester notes that stage lighting—in particular, a bright red spotlight—contributed to the

⁹ Chris Berry, “Every Colour Red? Colour in the Films of the Cultural Revolution Model Stage Works,” *Journal of Chinese Cinemas* 6, no. 3 (2012): 235.

¹⁰ Clark, *The Chinese Cultural Revolution*, 146.

¹¹ Kirk Denton, “Model Drama as Myth: A Semiotic Analysis of Taking Tiger Mountain by Strategy,” in *Drama in the People’s Republic of China*, ed. Constantine Tung and Colin Mackerras (Albany: State University of New York Press, 1987), 124–125.

characterization of hero Li Yuhe 李玉和 in *Hongdengji* 《紅燈記》 (The Red Lantern).¹² And Xiaomei Chen describes the adaptation of gestures from *xiqu* and acrobatics to the modern settings of the *yangbanxi* and how the stage directors of *Dujuan shan* 《杜鵑山》 (Azalea Mountain) draw attention to the physical movements of its heroine.¹³ Yet, even these scholars don't delve as deeply into the technical details of the productions as do film analyses.

The neglect of attention to design and technical elements parallels the trend that I discuss in the introduction, wherein the conspicuousness of the cinematic apparatus and film's unchallenged status as a "modern" medium have long since established the importance of including technical analysis in film critique. The theater, in contrast, trades in suspension of disbelief, tends to obscure its inner workings, and has made claim for its continued relevance on its status as an older art form. With the staged *yangbanxi*, local critiques that took place at *zuotanhui* 座談會 (discussion group) often focused on content—the plot, characterizations, precise wording of dialogue and arias. The facts that these critiques were then published and that we have relatively fewer visual records of the live performances have led to a disproportionately literary understanding of the model stage works.¹⁴ A comment made in an article by Ellen Judd encapsulates the general recognition of technical details as minor and subordinate to other aspects of the *yangbanxi*: Judd claims that the dramatic theory of the Three Prominences implied that the music, sets, and costumes were all to serve the primacy of characterization and the structure of contradiction (between heroes and villains) within the *drama*, and most *theatrical*

¹² Braester, *Witness against History*, 122–123.

¹³ Chen, *Acting the Right Part*, 116.

¹⁴ As several studies have noted, some of the *yangbanxi*, like *Hongdengji* 《紅燈記》 (The Red Lantern) and *Taking Tiger Mountain by Strategy* were recorded as "television documentaries" (*dianshi jilupian* 電視紀錄片) and broadcast nationwide. See for example Li Song 李松, ed., *Yangbanxi biannian shi houbian* 《「樣板戲」編年史》後篇 (Taipei: Xiuwei zixun keji, 2012), 274–6.

aspects “received little theoretical attention beyond indicating their purpose in the overall dramatic endeavor.”¹⁵ Or as Jiang Qing herself said in 1964, “the *script* is key.”¹⁶

However, as is often noted, elements like sets and costumes did not lack for practical attention or political endorsement. In July 1970, publication of five different versions of each *yangbanxi* were officially mandated: (1) a simplified script, (2) a production script, (3) sheet music (staff notation), (4) main melody music (simple notation), and (5) pictorial.¹⁷ The production scripts, in particular, run hundreds of pages and include a full production script (based on a particular performance), descriptions and diagrams of blocking and choreography, musical notation, production photographs, set design sketches and blueprints, full-color costume and makeup designs, prop illustrations and set lists, lighting plots, and cue lists for lighting, spot lights, and special effects. They were also printed in glossy red cover with gold titling, echoing the material form of *Mao zhuxi Yu Lu* 《毛主席語錄》 (Quotations from Chairman Mao) and thereby elevating their status to near that of the famous Little Red Book.¹⁸ [Figure 23]

The production manuals, with their excess of detail and glossy red-and-gold authority, provide further evidence of the importance of technical detail to the *yangbanxi* and testify to the labor invested in their development. By proportion alone, the amount of these manuscripts devoted to staging plans vastly over shadows the more traditionally literary script/libretto. In the production manual for *The Red Lantern*, for example, production photos and the script fill only the first 60 pages of the volume, with the next 100 pages containing music (in the simplified

¹⁵ Judd, “Prescriptive Dramatic Theory of the Cultural Revolution,” 105.

¹⁶ Jiang Qing, “On the Revolution in Peking Opera (Tan jingju geming),” trans. Jessica Ka Yee Chan, *The Opera Quarterly* 26, no. 2–3 (2010): 456, doi:10.1093/oq/kbq025.

¹⁷ Li Song, *Yangbanxi biannian shi houbian*, 275.

¹⁸ Clark, *The Chinese Cultural Revolution*, 87.

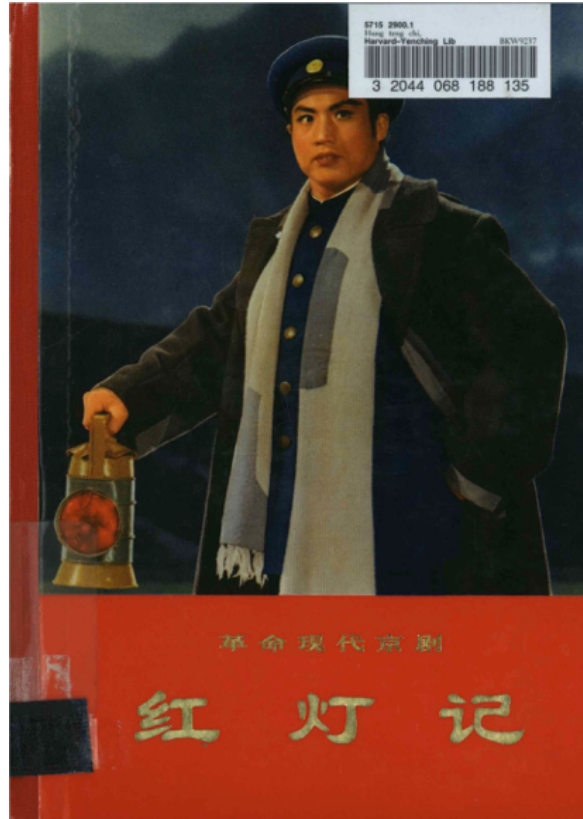

Figure 23 Cover of production manual for *The Red Lantern* (Source: *Geming xianfai jingju Hongdengji*, 1970)

notation, or *jianpu* 簡譜, common in China and more recognizable to most readers than Western staff notation) and 40 pages for choreography. The second half of the volume, about 140 pages, is devoted to set, prop, costume, makeup, and lighting design. The section on lighting in the production manual includes a lighting plot of almost 150 lighting units, ranging from strips of footlights to 2000-watt Fresnel lights to special *huandeng* 幻灯 for projected backdrop images.¹⁹

¹⁹ The use of *huandeng* background projections was perfected for the epic production of *Dongfanghong* 《東方紅》 (The East is Red) in 1964. The manuals actually do not contain much information on the use of *huandeng* in the *yangbanxi*, but from the diagrams and lists of lights, it is clear that most *huandeng* are positioned to illuminate the cyclorama/cyc (*tianmu* 天幕). For all other lights, a color is noted; even uncolored light is marked as *bai* 白 (white) in the lighting plots. So, it seems likely that the *huandeng* were used for projecting images and effects, like clouds rolling across the sky. Zhongguo jingju tuan 中國京劇團, *Geming xiandai jingju Hongdengji* 《革命現代京劇紅燈記》 (Beijing: Renmin chubanshe, 1970), 323–324.

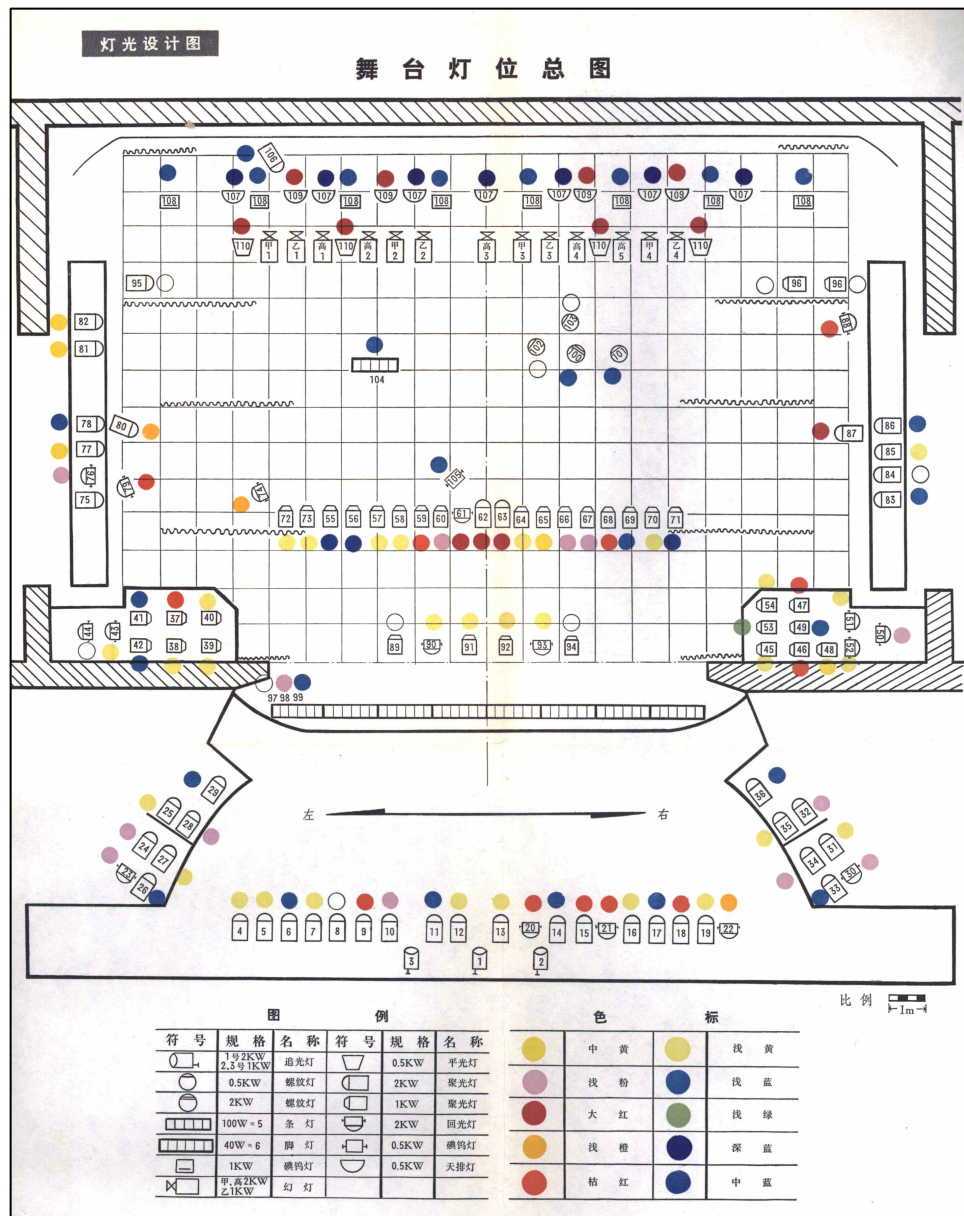
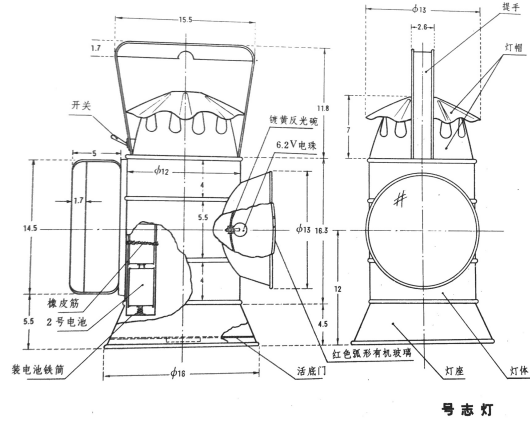

Figure 24 Lighting plot for *The Red Lantern* (Source: *Geming xiandai jingju Hongdengji*, 1970)

[Figure 24] There is a single, full-color master plot, followed by black-and-white drawings that indicate the location and focus direction for each act, and a detailed list of follow spot cues that instruct operators which characters to follow and what colors to use. Only heroic characters receive follow spots, in bright white light, light orange, or red, depending on the scene. And as if



道具制作图

301

Figure 25 Red lantern prop design for *The Red Lantern* (Source: *Geming xiandai jingju Hongdengji*, 1970)

to avoid any misinterpretation of the shades of orange or red, the lighting plots also include color charts—a move that might be expected, even the demonstrated attention to color in the *yangbanxi* films.

Some of the *yangbanxi* took this dependence on design and technical detail a step further to make the drama itself rely on these elements. To again cite *The Red Lantern*, we find on one page among the many drawings and diagrams a sketch of the eponymous prop. [Figure 25] As can be seen from the sketch, the prop signal lantern was to be functional, with a small 6.2V light bulb powered by two “number 2” batteries (held in place by a rubber band) and shining through a curved piece of red glass. A switch turns the light off and on, although the detailing stops short of explaining how the electrical wiring inside the lantern would work. As Yomi Braester has demonstrated, the red lantern functioned on multiple levels within the world of the opera. On the one hand, it was an obvious and direct reference to Chairman Mao, who during the Cultural Revolution was often described and depicted as a bright red sun. The lantern also functioned as an heirloom, possession of which designates the next generation of revolutionaries, and within a

system of revolutionary codes wherein recognition of the lamp indicates one's membership in a community of guerilla communist soldiers.²⁰ It is the materialization of the aesthetic mandate “red, bright, shining” (*hong guang liang* 紅光亮),²¹ but its ability to manifest these properties onstage depended on a theater troupe's ability to follow the precise instructions of the production manual (and what one hopes was a very sturdy rubber band). All this suggests that while the script may have been key, as much care was lavished on design and technical detail as on revision of content. Perfection of form very much depended on technical precision.

Yet, in keeping with the Cultural Revolution emphasis on mass culture, none of the volumes references their creative team as anything other than a collective. For instance, the authorial attribution for *The Red Detachment of Women* reads: “collectively revised and performed by the Chinese Dance-Drama Troupe (Zhongguo wujutuan jiti gaibian ji yanchu 中國舞劇團集體改變及演出).” Even in materials published after the Cultural Revolution, which often mention playwrights, directors, and lead actors, it can be difficult to find the names of the set and lighting designers. One exception is the Beijing volume of the *Zhongguo xiqu zhi* 《中國戲曲志》 (Chinese *Xiqu* Gazetteer), compiled in 1999, which lists four scenic designers for the Beijing *Jingju* Troupe (Beijing jingju tuan 北京京劇團) production of *The Red Lantern* in 1964: Li Chang (see Chapter 2), An Zhenshan 安振山, Zhao Jinsheng 趙金聲, and Guo Dayou 郭大有.²² However, it does not note whether or not these same designers were involved with the team

²⁰ Braester, *Witness against History*, 121–127.

²¹ Some scholars translate as “red, smooth, luminescent.” See Jiehong Jiang, *Burden or Legacy: From the Chinese Cultural Revolution to Contemporary Art* (Hong Kong: Hong Kong University Press, 2007), 20; Richard King et al., *Art in Turmoil: The Chinese Cultural Revolution, 1966-76* (Hong Kong: Hong Kong University Press, 2010), xi.

²² “Hongdengji 紅燈記,” Zhongguo xiquzhi bianji weiyuanhui 中國戲曲志編輯委員會, *Zhongguo xiqu zhi* 《中國戲曲志》, Beijing juan shang 北京卷上 (Beijing: Zhongguo ISBN zhongxin, 1999), 234.

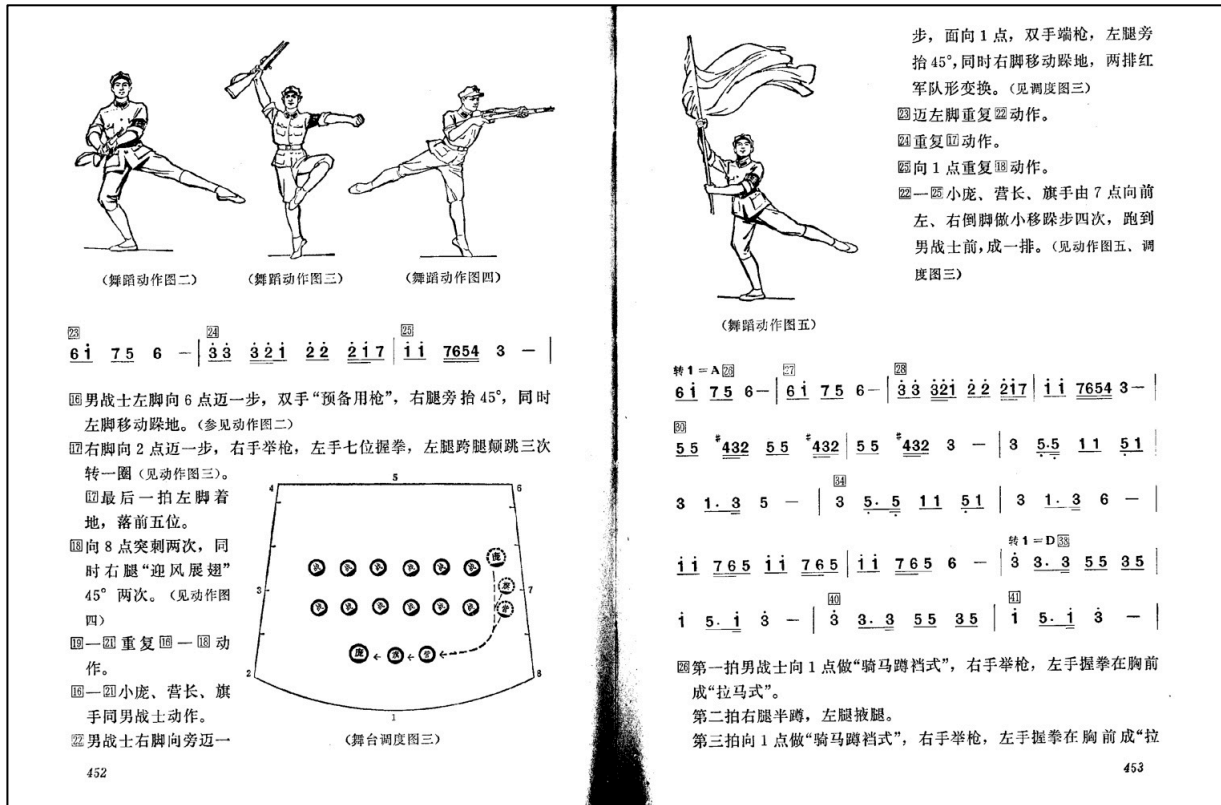

Figure 26 Choreography from *Red Detachment of Women* production manual (Source: *Geming xiandai wuju Hongse niangzi jun*, 1970)

that designed later productions or the film version, and a similar entry for the model opera *Shajiabang* 《沙家浜》 neglects to mention any information on its design team. The manuals elevate technical details while obscuring the human individuals behind them.

Within the production manuals, this erasure of the human also occurs on a textual level. If we take *The Red Detachment of Women* as an example, we find several hundred pages of text occupied by detailed descriptions of the ballet's choreography. [Figure 26] A key at the beginning of the choreography section designates a simplified notation for each character, such as Wu 吳 for the main character of Wu Qinghua 吳清華, or simply *qun* 群 for a group of dancers. On subsequent pages, the characters disappear as their simplified names overtake sketch after sketch of the stage, small signs marching in perfect formation. Anonymous line-drawn figures,

appropriately costumed, appear next to these diagrams to demonstrate the proper movements and gestures for each sequence.²³ While such simplification and schematization is perhaps a necessity of any notation system, in the context of the *yangbanxi*, these human figure drawings seem here to perfectly capture the ethos of the “model.” Drawn in the same style and with the same precision as the blueprints for props that appear a few pages later in the book, these figures imply a transformation of the dancer’s body into a stage property.

Of course, these manuals also serve a much more practical function: to provide a blueprint for future productions of the *yangbanxi*. And while no English-language studies of the Cultural Revolution yet attempted a detailed analysis of the production manuals’ content and form, scholars do often discuss the manuals in this capacity. Paul Clark, for instance, sees them as designed to enable standardized performances of the *yangbanxi*, a function that they in fact shared with the film versions:

Putting the model performances on celluloid offered the Cultural Revolution cultural leaders the means to standardize a version of each of the models that could be seen in this fixed form in all corners of China...Amateur or local attempts at and even abuse of the models would be superseded by a visual record of the official versions, against which any live performance of an aria or a whole opera could be measured.²⁴

In addition, the first film *yangbanxi* and the publication of the production manuals in 1970 coincided with *yangbanxi* promulgation (*dali puji yangbanxi* 大力普及樣板戲) campaign. With more amateurs than ever before attempting *yangbanxi* performances, and with their chances for transformation into revolutionary heroes hanging in the balance, there was an urgent need to

²³ We might compare these to the movement manuals (*shenduan pu* 身段譜) sometimes composed for *xiqu* works. However, whereas a *xiqu* star’s *shenduan* could be a very carefully guarded secret, *yangbanxi* choreography was, ostensibly, to be widely copied.

²⁴ Clark, *The Chinese Cultural Revolution*, 123.

disseminate standardized guides for proper productions. In short, there was an imperative to transform live performance itself into something reproducible on a grand scale.

In a recent article, Laurence Coderre examines this phenomenon of amateur *yangbanxi* productions, but suggests that investment in the standardization of the production process via film and print materials in fact was linked to a suspicion about the effectiveness of “performance as a technology of transformation.”²⁵ Jason McGrath has raised a similar concern in his analysis of the “formalist drift” in *yangbanxi* films, arguing that: “The stylized performance becomes such pure spectacle that the ideological content, precisely by being so rigorously formalized, threatens to become mere surface itself, a superficial appearances that in fact reveals nothing.”²⁶ Focusing on stage performance, Coderre calls attention to a gap between “playing” and “becoming” in performance and argues that the failures and even parodies of amateurs playing villains show how, on multiple levels, the *yangbanxi* could fail to transform ordinary men into revolutionary heroes. According to Coderre:

the *yangbanxi* villain is perhaps a better saboteur than we normally give him credit for, undermining the (re)production of ‘real-life’ heroes through performance by casting doubt on the feasibility of a perfect correspondence between appearance and essence, body and person. Perhaps—just perhaps—he succeeds in keeping the transformative technology of amateur performance from coming full circle.²⁷

This interpretation, for all its merits, has a blind spot: it takes Cultural Revolution dramatic theory at face value. It does not question the notion that one primary goal of the Cultural Revolution was to transform *actual* performers and audiences into ideal revolutionary heroes via

²⁵ Laurence Coderre, “Breaking Bad: Sabotaging the Production of the Hero in the Amateur Performance of Yangbanxi,” in *Listening to China’s Cultural Revolution: Music, Politics, and Cultural Continuities*, ed. Paul Clark, Laikwan Pang, and Tsan-Huang Tsai, Chinese Literature and Culture in the World (New York: Palgrave Macmillan, 2015), 73.

²⁶ Jason McGrath, “Cultural Revolution Model Opera Films and the Realist Tradition in Chinese Cinema,” *The Opera Quarterly* 26, no. 2 (2010): 370.

²⁷ Coderre, “Breaking Bad,” 74.

the reception and reproduction of *yangbanxi*. However, what I would like to argue here is that an examination of the technical elements of their production manuals suggests that this was not in fact the case. If we return to the design materials included in the manuals, we find that the blueprints and diagrams in fact encode a certain amount of information not only on the ideal staging of the *yangbanxi*, but also on the ideal *stages* for the *yangbanxi*. For example, the stage layouts and lighting plots for *The Red Lantern* include a scale marker of 1cm to 1m that allows us to measure the proscenium opening, width, and depth of the stage: 11m, 18m, 13.5m.²⁸ From the locations of the lighting units, we can see that the theater depicted would have had a number of pipes hanging over the stage, as well as dedicated spaces to the sides of the stage and above the audience for hanging lights. The lighting plot for *The Red Detachment of Women* provides even more detail, indicating a total of 51 hanging pipes above the stage, although the plot does not require use of all of them.

From these technical specifications, revealed by the production manuals, it is clear that the *yangbanxi* were designed to be staged in distinctly modern theater spaces, themselves modeled on the Western proscenium theater. We also know that these manuals were published to help promote and guide amateur performance of the *yangbanxi*. This begs the question: would amateurs even have had access to the basic hardware—a proscenium stage, lighting units—necessary to properly follow the guidebooks? On the one hand, the theater space implied by the manuals was the very type of theater that was built throughout the country during the 1950s, after the founding of the PRC and before the economic disasters of the Great Leap Forward brought a halt to non-essential construction. If we believe the statistics, there would have been over 3000 professional grade theaters in the PRC by 1960. The volume compiled by the

²⁸ Zhongguo jingju tuan, *Geming xiandai jingju Hongdengji*, 323–324.

Tsinghua Department of Architecture in 1960 suggests that many of these may have been about the size required by *The Red Lantern*. In its list of dimensions for 72 theaters around the country, nearly all have dimensions similar to 11x18x13.5, and many are *wenhuagong* 文化宮 (cultural palaces), which perhaps would have been open to use by local amateur groups.²⁹ In addition, if we take seriously the mandate that *all* 60 million PRC citizens transform into model citizens, the number of modernized theaters in the early 1970s begins to seem woefully inadequate to the revolutionary project.

The true difficulties come with the specifications for the lighting equipment. Recall, as discussed in Chapter 2, that the provisioning of the Capital Theater in Beijing required the personal intervention of Premier Zhou Enlai in order to process an order for imported lighting units. Paul Clark's analysis demonstrates how the need for domestically produced color film stock reinvigorated the technical side of the film industry during the Cultural Revolution. But what of the need for high-powered, colored stage lighting and pulley-driven pipe systems from which to hang them? Were there enough domestic factories to produce the kind of lighting equipment required by the *yangbanxi*, and were local electrical systems able to handle the wattage required by upwards of a hundred high-wattage lights? Anecdotal evidence confirms the validity of these suspicions that *yangbanxi* lighting, as scripted, would have been difficult or even impossible in many locations. Writing immediately after the end of the Cultural Revolution, when the *yangbanxi* were subjected to severe criticism, one theater artist recalls:

Watching this play made me think of when Jiang Qing and her cronies took control of my theater troupe. Under their counterrevolutionary revisionist line, they raised the flag of 'maintaining artistic quality' and single-mindedly pursued their so-called 'realism,' vigorously creating 'heavy industry' onstage, squaring and wasting resources. The set pieces had to be three-dimensional, the flowers and grasses had to be made of plastic, and

²⁹ Qinghua daxue, *Zhongguo Huitang Juchang Jianzhu*, Appendix.

they made stipulations for the scene without any regard for aesthetics. Costumes were made of silk, wool, and polyester. The lighting always used nine or ten thousand watts, and when we went down to the villages and factories, we needed seven or eight trucks to lug all of the scenery and cases. Sometimes they even needed to stop some production in order to divert electricity to illuminate the stage.

看了戲，使我們想到，過去江青及其親信直接插手控制我團，在它們的反革命修正主義路線下，打着‘保證藝術質量’的旗號，一味追求所謂‘真實’，在舞台上大搞‘重工業’，揮霍浪費，景片要立體的，花草要塑料製的，不管審美規定情境，人物穿的是絲綢，毛呢，的確良，燈光用電動輒就是九十萬瓦，有時下鄉下廠演出，拉景拉箱的卡車要七八輛，甚至於要停止一部分生產，抽調電力才夠舞台照明用。³⁰

Even in this professional performer’s experience, spreading the *yangbanxi* required the transportation of a massive amount of material and equipment to the location of performance, and the electric grid, apparently, could barely support the requirements of the lighting. If this was the case for touring professionals, what then of amateurs? What of rural areas yet awaiting electrification?

This technical flight of supposition continues beyond stage dimensions and lighting equipment to the issue of technique. It is certainly no coincidence that the *yangbanxi* performance forms themselves share the characteristic of technical difficulty; *jingju*, ballet, and orchestral music at their best require performers to train for years to achieve even basic competence. They are, therefore, ideal forms for the biopolitical disciplining of the body. The fact that many of the precisely moving figures in the *yangbanxi* are associated with the military in some way only further strengthens the association between command of the body and command of the state. The detailed breakdown of choreography in the *yangbanxi* manuals—each gesture meticulously matched to accompany musical notation, complex sequences broken down into individually illustrated steps—offers a tantalizing suggestion that everyman and

³⁰ Xinjun 欣君, “Xuexi *Chusheng de Taiyang* wutai meishu de tihui 學習《初升的太陽》舞台美術的體會,” *Renmin xiju* 《人民戲劇》 6 (1976): 20–21.

everywoman can transform themselves into a pirouetting revolutionary hero. Perfectly synchronized *grand jeté* are only a matter of diligent study, physical sacrifice, and the ideologically correct mindset.

However, weavers can no more transform themselves into ballet dancers or *wudan* 武旦 (female martial role type actors) without the proper training than backyard furnaces can smelt rusting farm tools into military-grade alloys. How could an amateur even approach the kind of kinesthetic transformation to which the *yangbanxi* aspired, without the years of training required to act (or rather, dance) the part? Only a professional could hope to achieve the technical perfection required of the parts in the *yangbanxi*, but there lies another paradox. Experts, with a few exceptions, were persecuted during the Cultural Revolution. And as much as the *yangbanxi* needed professional-quality performers, their very technical expertise posed a problem: how could one ever tell if a dancer was actually committed to her revolutionary role, as opposed to mechanically executing a series of *tombé* and *plié*? In other words, how to determine if a performer was simply “going through the motions”—*zou guochang* 走過場?

In titling its most technically difficult scene a *guochang*, the script for *The Red Detachment of Women* seems almost self-aware of the common theatrical term’s secondary, metaphorical usage, which indicates a task done in a perfunctory way.³¹ It also retains a sense of performativity, in that the actions in question are for the benefit of an observer, rather than the actor. In the scene from *The Red Detachment of Women*, with which I began, this secondary meaning of the “interlude” seems at odds with the intended display of “indomitable will” in the choreography, yet, at the same time, hints at one of the underlying dangers of a technically difficult scene, or indeed, any theatrical performance—that it ultimately could be just for show.

³¹ Definition: “比喻敷衍了事，做給別人看。” Entry from *Guoyu cidian* 《國語辭典》 on www.zdic.net.

Those carefully choreographed formations and synchronized lines of leaping dancers require a precision and a focus on the technique that belies the possibility of amateur reproduction and the total immersion of the actor into the character alike.

As discussed earlier, scholars like Braester, McGrath, and Coderre have already analyzed the particular problems of participation, transformation, and perception at work in the revolutionary *yangbanxi*. Reading carefully the details of the *yangbanxi* production manuals reveals to us how utterly impossible it would have been for any amateur troupe to even approach a reproduction of their contents. The manuals therefore imply an ideal form to which all performances and performers were meant to *aspire*, but which at the same time forestall their own realization. In this sense, the production manuals mirror on a technical level the semiotic system of the *yangbanxi* described by Yomi Braester in his chapter on “the purloined lantern” in *Witness Against History*. Braester demonstrates how the plot of *The Red Lantern* enacts the passing of a code and encoded messages among underground revolutionaries. The meaning of the most important messages, however, is endlessly deferred, unknowable to all but the highest powers in the Party. Likewise, the *yangbanxi* are an ideal form unachievable by anyone other than the few highest level, best trained and best resourced, troupes from achieving. To return to Coderre’s argument about failure as subversive, what I offer here is the suggestion that failure may not be subversive, cannot be subversive, if its inevitability is encoded into the project of revolutionary reproducibility from the beginning. The *yangbanxi*, without a doubt, function as a “technology” of the state apparatus. However, as with any technology, they are not only capable of failure, but *prone* to failure.

In his article on color in *yangbanxi* films, Chris Berry remarks that, “Although it may be that Jiang Qing wished that getting the right shade of red in *On the Docks* would directly transform the viewer into a red guard, it is unlikely she or anyone else would believe this could happen.”³² Here, I argue that neither Jiang Qing nor anyone else in power even *wished* that the right shade of red transform a viewer or performer into a red guard. Rather, all that was necessary was that the *performer* believed this impossibility possible and committed herself to its inevitable incompleteness. Continuous revolution was sustainable only if the revolution was taking place at a personal level. When political enemies have been vanquished and the “four olds” toppled, the last front left was the individual psyche. One can never prove that revolutionary transformation of the human spirit has been complete. One can never even be certain of one’s own transformation.

Metaphors of theater as a technology or weapon of the state and political life as theater abound in discussions of the Cultural Revolution. Such lofty metaphors seem much removed from the mundane and the material sides of *yangbanxi* performance, as recorded in their production manuals. The manuals certainly functioned, as previous scholarship has argued, to make the *yangbanxi* standardized and suggest their reproducibility. They contributed to the fantasy that an ordinary citizen could transform herself into a revolutionary hero via performance. However, taking these manuals as texts worthy of deeper analysis and reading between the line drawings also suggests that the utopian vision of the Cultural Revolution operated not only through grandiose narratives and revolutionary transformation, but also on a technical level.

³² Berry, “Every Colour Red?,” 241.

This argument clearly awaits further research and deeper analysis. For the moment, this interlude remains, like the *grande jeté* photograph from *Red Detachment*, frozen in motion and awaiting later reanimation.

Chapter 3

The Multimedial Actor: Technique, Training, and Anti-Technology in 1980s PRC and Taiwan

Audience members entering the theater in Beijing for a performance of *Hong bizi* 《紅鼻子》 (The Red Nose), staged by the China Youth Arts Theater (Zhongguo qingnian yishu juyuan 中國青年藝術劇院) in February 1982 were confronted with an unusual tableaux. No curtain hid the stage from view; instead, a hotel lobby with a minimalist aesthetic spread before them, flooded with a dim blue light and the dulcet tones of Taiwanese folk songs (*minge* 民歌). Stagehands in grey outfits purposefully and unabashedly adjusted set props and tested sound cues in full view (and earshot). Spectators may even have caught one of those stagehands in casual conversation with another audience member, explaining the exposed lighting equipment encircling the playing space or the five scroll-like strips of fabric hanging upstage in place of a painted backdrop. A bell would then chime once, twice—and, before the house lights had fully dimmed, the actors would take the stage and hold in place until a third bell brought down the lights and began the show.¹

Audience surprise would hardly have ended there, however. In fact, any number of things about this production could have struck them as unusual and, according to reviews, did. The piece, by playwright Yao Yi-wei 姚一葦 (1921-1997), marked the first time work written in Taiwan, set in Taiwan, had been seen in the PRC. As such, it offered a snapshot of life in a place that had been cut off from mainland China for more than thirty years yet was home to not a few

¹ This description based on the *Hong bizi yanchu ben* 《紅鼻子》演出本, corroborated by essays by the director, designers, and audience responses to the show. Lin Kehuan 林克欢, ed., *Hong bizi de wutai yishu* 《〈紅鼻子〉的舞台藝術》 (Beijing: Zhongguo xiju chubanshe, 1984), 55.

long-lost family members. Into this void, *The Red Nose* brought a colorful cast of characters from all walks of Taiwanese life: a couple vacationing with their daughter, a wealthy businessman, a frustrated composer, a few failing small-time manufacturers, and a traveling variety show troupe, all trapped at the hotel due to inclement weather. It also did so without relying on the conventions of realist drama, the naturalistic performance style that had dominated the *huaju* stage in previous decades, or the revolutionary aesthetic of the *yangbanxi*. Instead, on the literary level, the play was structured around mundane conversations among groups of guests staying at a seaside hotel and focused on character development more than any through-line of action. The performers themselves further impressed audiences by breaking into song, dance, acrobatics, and magic tricks onstage, bringing the carnivalesque spirit of the variety troupe into a space often reserved for more serious fare and delighting spectators with displays of technique all too rare for *huaju* actors.

All of this, furthermore, is captured in a slim volume: *Hong bizi de wutai yishu* 《〈紅鼻子〉的舞台藝術》 (The Stage Art of *The Red Nose*), published two years after the performance. While on the one hand uneasily reminiscent of the production manuals published for Cultural Revolution *yangbanxi*, the “Stage Art” volume seems to seek to commemorate, but not codify, the 1982 production of *The Red Nose*. In place of rigid diagrams and copious detail, it includes personal accounts from the director, designers, and actors and highlights their individual contributions to rehearsals and performances. They appear as collaborators, but not a collective. Blocking diagrams and descriptions of lighting effects also are included in the volume’s production script, but instructions for choreography, cue sheets, and blueprints are absent. Far from a work of rigid proscription, the resulting volume gives the impression of an idiosyncratic record of an ephemeral creative process.

In showcasing backstage technologies and labor, as well as the virtuosity and versatility of the acting body, the China Youth Arts production of *The Red Nose* raises an important question about the distinction, or perhaps lack thereof, between *technology* and *technique*. In Chinese, the terms commonly used for the two in relation to the stage—*jiqiao* 技巧 (technique) and *jishu* 技術 (technology)—share a term, and in their classical usage converge on a meaning closer to technique, or skill. In contemporary parlance, the synonymy is retained to a certain extent, with *jishu* taking on additional applications in relation to material equipment and the practical application of scientific knowledge. Yet, inevitably, when we talk about *a* technology, we must also talk about how it is used, its attendant *technique*, as I have indeed done throughout this dissertation. And even with their multiple meanings, both remain well within the bounds of a broader understanding of stagecraft as technics (as discussed in the Introduction).

In this chapter, I argue that this question of the line between technology and technique became newly relevant to Chinese theater artists in the period immediately following the end of the Cultural Revolution in 1976. The attempted cooptation of the cultural sphere and effective transformation of the theater *into* a technology of the state during the Cultural Revolution (discussed in the Interlude), made it imperative for theater artists to reclaim both staging technology and technique as *art*. They did so by reasserting control over their primary means of (artistic) production—the technologies and techniques of actor training—and by producing a number of theatrical works and canonizing texts that emphasized creative *process*. This in turn works to repudiating the principles of perfection and reproducibility that drove the *yangbanxi*.

To demonstrate this, I will begin with a brief overview of the years following the Cultural Revolution, during which there was a reassertion of the importance of science and technology that influenced and paralleled trends in the theater. Then, I will show how the issue of actor

technique rose to the fore during attempts to restart theater-training programs that had been suspended during the Cultural Revolution. Through discussions of how to train acting students, the *huaju* actor came to be redefined as what I will call a “multimedial actor”—a versatile performer possessing all the virtuosity of a classically trained *xiqu* actor or ballet dancer, but neither trapped by conventionality nor subject to the discipline of revolutionary choreography. This multimedial actor is what is then staged alongside technology in *The Red Nose*, and indeed, throughout a larger body of metatheatrical plays written and produced in the 1980s. Overall, much work of this period functions as a kind of anti-technology, wherein the technologies worked against are those of revolutionary art and the state ideological apparatus.

Science and Technology in Content and Form: Staging the Four Modernization

The death of Chairman Mao in 1976 and the fall of the “Gang of Four”—Jiang Qing 江青 (1914-1991), Zhang Chunqiao 張春橋 (1917-2005), Yao Wenyuan 姚文元 (1931-2005), and Wang Hongwen 王洪文 (1935-1992)—soon thereafter brought an end to the ten years of chaos and trauma that were the Cultural Revolution. In the political realm, power struggles had in fact been ongoing for several years, and industrial and cultural activity, in some areas, had already begun to resume. The Beijing People’s Art Theater, or BPAT (Beijing renmin yishu juyuan 北京人民藝術劇院), for instance, started staging new *huaju* as early as 1972, although they would not return to their home at the Capital Theater until after 1976. The formal conclusion of the Cultural Revolution and downfall of Jiang Qing, however, meant that the reign of the *yangbanxi* could also be officially ended. In the latter half of 1976, articles in newspapers and theater periodicals, like *Renmin xiju* 《人民戲劇》 (The People’s Theater) vehemently denounced the *yangbanxi*—by then, numbering more than eight—for their imposition of a uniform aesthetic on

the performing arts, the excessive resources devoted to the perfection of only a few works of art, and their dogmatic promulgation.² Theater artists who had been persecuted during the Cultural Revolution were rectified, and those who had been sent to labor in the countryside returned to their theater troupes, and performance resumed. *Huaju*, which had been sidelined when *jingju* and ballet were selected as the best genres for “revolutionary model” theater, returned in full force.³ At first, cautious playwrights focused on producing hagiographies of Party leaders, but by 1978-1979, the promise of new freedoms under a new Constitution and the directives issued by the Central Committee of the Eleventh Congress of the CCP encouraged artists and writers to experiment with politically critical and formally innovative new work.⁴ As these artists, especially playwrights, reflected on the past decade and responded to the changed circumstances, they followed the broader literary trends of “scar literature” (*shanghen wenxue* 傷痕文學) and “root-seeking literature” (*xungen wenxue* 尋根文學).⁵ Meanwhile, the general spirit of “opening up” to the outside world encouraged publication of foreign theater theory and descriptions of

² See, for example, the several issues of criticism of Jiang Qing and her “theater hegemony” in issues of *Renmin xiju* 《人民戏剧》 (People’s Theater) published in the latter half of 1976.

³ Contrary to the narrative promoted by some PRC theater histories, *huaju* did not completely die out during the Cultural Revolution. We certainly should not overlook the fact that many theater artists, even those who had been devoted to the Leftist political cause and then later to the CCP, were persecuted and killed during that period. However, as much recent Cultural Revolution scholarship has shown, the situation was more nuanced and complex than has been acknowledged. In the case of *huaju*, some state-sponsored theater companies, like BPAT, resumed productions in the early 1970s, and, as Paul Clark has discussed, Red Guards themselves put on a certain number of *huaju* plays. Yang Jian 楊健, “Wenhua dageming zhong de hongweibing huaju 文化大革命中的紅衛兵話劇,” *Zhongguo qingnian yanjiu* 《中國青年研究》 1 (1995): 34–37; “Wenhua dageming zhong de hongweibing huaju 文化大革命中的紅衛兵話劇,” *Zhongguo qingnian yanjiu* 《中國青年研究》 2 (1995): 25–28; Clark, *The Chinese Cultural Revolution*, 192–201.

⁴ For a concise overview of post-Cultural Revolution developments in Chinese theater, see Constantine Tung, “Introduction: Tradition and Experience of the Drama of the People’s Republic of China,” in *Drama in the People’s Republic of China*, ed. Colin Mackerras and Constantine Tung (Albany: State University of New York Press, 1987), 13–20.

⁵ For an overview of major trends in 1980s Chinese drama, see Haiping Yan, “Theater and Society: An Introduction to Contemporary Chinese Drama,” in *Theater & Society: An Anthology of Contemporary Chinese Drama*, ed. and trans. Haiping Yan (Armonk, NY: MESHARPE, 1998), ix – xlvii.

what has since been termed the “post-dramatic theater” in newly reinvigorated newspapers and periodicals.⁶ Many theater artists eagerly traded Great Leap slogans of “quantity, speed, quality, efficiency” (*duo kuai hao sheng* 多快好省) and Cultural Revolution dictums of “red, bright, shining” (*hong guang liang* 紅光亮) for an ethos of exploration (*tansuo* 探索).

Previous scholarship on theater of this period has largely focused on this exploratory ethos, at times arguing for terming it “experimental” theater (*shiyan xiju* 實驗戲劇) or even an avant-garde theater (*xianfeng xiju* 先鋒戲劇).⁷ The works included under these umbrella terms typically took place in blackbox theaters or non-traditional spaces, and therefore are also collectively referred to as “little theater” (*xiaojuchang* 小劇場), a name shared with the contemporaneous Taiwanese Little Theater Movement as well as the American Little Theater movement of the 1910s.⁸ In studies of little theater in mainland China, the twin issues of the influence of Western modernism and a turn to indigenous traditions have structured much of the discussion. Scholars such as Xiaomei Chen and Claire Conceison, for example, both draw on the

⁶ Most arts-related periodicals ceased publication during the Cultural Revolution.

⁷ During the 1980s, the term “exploration” (*tansuo* 探索) was used widely to describe a variety of new directions taken in dramatic literature and theatrical performance. As theater scholar Rossella Ferrari has noted, some artists working on more aesthetically or politically contentious projects would also refer to “theater experiments” (*xiju shiyan* 戲劇實驗), but were careful to avoid the term “experimental theater” (*shiyan xiju* 實驗戲劇) and its too-close association with “bourgeois liberalism” and “decadent” strands of Western modernism. Some scholars, Ferrari included, have argued for the use of the term “avant-garde” (*xianfeng* 先鋒) to describe Chinese experimental theater of the 1980s. There is a robust body of scholarship in both Chinese and English on experimental theater of the 1980s. Chen Jide 陳吉德, *Zhongguo dangdai xianfeng xiju, 1979-2000* 《中國當代先鋒戲劇, 1979-2000》 (Beijing: Beijing xiju chubanshe, 2004); Zhang Zhongnian 張仲年, ed., *Zhongguo shiyan xiju* 《中國實驗戲劇》 (Shanghai: Shanghai renmin chubanshe, 2009); Ferrari, *Pop Goes the Avant-Garde*, 7–19.

⁸ The term “little theater” has also been used for small-scale amateur productions, and it is in this capacity that it was first introduced to China in the first decades of the 20th century (Chen Dabe 陳大悲, *Aimei de xiju* 《愛美的戲劇》 (Shanghai: Shanghai shudian, 1992; originally published Shangwu yinshua guan, 1946). For an overview of the Taiwanese Little Theater Movement, see: Mingder Chung, “The Little Theatre Movement of Taiwan (1980-1989): In Search of Alternative Aesthetics and Politics” (PhD Dissertation, New York University, 1992). On American Little Theater, Constance D’Arcy Mackay, *The Little Theatre in the United States*, (New York: H. Holt and Company, 1917); Dorothy Chansky, *Composing Ourselves: The Little Theatre Movement and the American Audience* (Carbondale: Southern Illinois University Press, 2004).

work of Edward Said and a range of scholarship in postcolonial studies and intercultural theater to describe the construction of a Western Other vis-à-vis Chinese theatrical traditions and aesthetics.⁹ International interest in Nobel laureate Gao Xingjian 高行健 (b. 1940) has also drawn attention to his work and to the theater landscape of this period more generally.¹⁰ Gao wrote a number of important theoretical works and controversial plays in the early 1980s, one of which—*Juedui xin hao* 《絕對信號》 (Absolute Signal, 1982)—is frequently credited as the birth of the little theater movement in China. His collaborations with BPAT director Lin Zhaohua 林兆華 (b. 1936) on *Absolute Signal*, *Chezhan* 《車站》 (Bus Stop, 1983), and *Yeren* 《野人》 (Wildman, 1986) are also considered widely influential, even though Gao himself would leave China for France in 1987 and be blacklisted by the PRC government.

As much of this scholarship has noted, the political changing-of-the-guard that occurred in the late 1970s brought with it not only new freedoms, but also new policies aimed at achieving the “four modernizations” in agriculture, industry, national defense, and science and technology. Of especially high priority were technological fields such as energy sources, computers, laser and space technology, high-energy physics, and genetics.¹¹ Technical experts, vilified and persecuted during the Cultural Revolution, saw their fates reversed, and programs were even established to send thousands of researchers in science and technology to the United States for

⁹ Chen, *Acting the Right Part*; Chen, *Occidentalism*; Conceison, *Significant Other*.

¹⁰ There is a rich body of scholarship on Gao Xingjian’s theater in English, much of which also offers nuanced discussion of contemporaneous developments in Chinese theater. See for example: Yiheng Zhao, *Towards a Modern Zen Theatre: Gao Xingjian and Chinese Theatre Experimentalism* (London: School of Oriental and African Studies, University of London, 2000); Kwok-kan Tam, *Soul of Chaos: Critical Perspectives on Gao Xingjian* (Hong Kong: The Chinese University Press, 2001); Sy Ren Quah, *Gao Xingjian and Transcultural Chinese Theater* (Honolulu: University of Hawai’i Press, 2004); Izabella Łabędzka, *Gao Xingjian’s Idea of Theatre: From the Word to the Image*, *Sinica Leidensia* ; v. 87 (Leiden: Brill, 2008); Todd J. Coulter, *Transcultural Aesthetics in the Plays of Gao Xingjian* (New York: Palgrave Macmillan, 2014); Mary Mazzilli, *Gao Xingjian’s Post-Exile Plays: Transnationalism and Postdramatic Theatre* (New York: Bloomsbury Methuen Drama, 2015).

¹¹ Spence, *The Search for Modern China*, 655.

training. These broad mandates translated into policies influencing performing arts troupes in several ways. First, as Colin Mackerras has noted, the early 1980s saw a marked reduction in amateur theater activities and a push for higher standards and professionalization in state-sponsored troupes like BPAT—in short, efforts to apply the ethos of “modernization” to the theater as well as to agriculture, industry, military, and science.¹² This involved concerted efforts to elevate production value in both an economic and a material sense. Many theater troupes that had been entirely dependent on the government for funding saw the level of support decrease and shifted to a partial profit-sharing model. The logic behind this institutional shift was that if salaries depended on ticket sales, theater troupes would need to raise the quality of their performances in order to attract larger and higher-paying audiences.¹³ For the troupes, this meant improving all elements of productions: acting and directing, as well as the technical elements of the performance. Accordingly, the early 1980s saw a surge in attention to scenography through events like an exhibition on the history of scenic design held in Beijing in 1980-1981 and new publications on stage design and technology supported by the Department of Science and Technology within the Ministry of Culture (Wenhuabu kejiju 文化部科技局).¹⁴

¹² Colin Mackerras, “Modernization and Contemporary Chinese Theatre: Commercialization and Professionalization,” in *Drama in the People’s Republic of China*, ed. Constantine Tung and Colin Mackerras (Albany: State University of New York Press, 1987), 181–212.

¹³ At the same time, this also brought concerns of over-commercialization and the commodification of art. Mackerras discusses these concerns in the context of the early 1980s, but the debate would come to a head in the 1990s as the performing arts began to face even stronger competition from mediatized forms of entertainment like television. *Ibid.*, 202–203.

¹⁴ The journal *Wutai meishu yu jishu* 《舞台美術與技術》 (Stage Art and Technology) began publication in 1980-1981; the Dramatists Association 劇協 and Fine Arts Association 美協 published *Shoudu wutai meishu sheji ziliao xuan* 《首都舞台美術設計資料選》 and *Guowai wutai meishu zhaoxiang ziliao* 《國外舞台美術照相資料》. Li Chang 李暢, “Wutai meishu duoyuanhua 舞台美術的多樣化,” in *Zhongguo xiju nianjian 1982* 《中國戲劇年鑑 1982》, ed. Zhongguo xiju nianjian bianji bu 中國戲劇年鑑編輯部 (Beijing: Zhongguo xiju chubanshe, 1982), 16. Other volumes on stage design and technology published in the early 1980s include: Zhongguo yishu yanjiuyuan xiqu yanjiusuo 中國藝術研究院戲曲研究所, ed., *Wutai meishu wenji* 《舞台美術文集》 (Beijing: Zhongguo xiju chubanshe, 1982); Ouyang Luohan 歐陽勞汗, *Wutai meishu sheji gaishuo* 《舞台美術設計該說》 (Guiyang:

In a marriage of form and content tentirely typical of Chinese socialist theater, but which has been little noted by scholarly work on this period, plays *about* scientists also occasioned experimentation with new staging techniques and technologies. For instance, Bertolt Brecht's *The Life of Galileo* (translated as *Jialilue zhuan* 《伽俐略傳》), was staged by the China Youth Arts Theater in March 1979.¹⁵ As director Chen Yong 陳顥 (1929-2004) explains, the selection of this play took into equal consideration the opportunity to introduce Brecht to the Chinese public, the need to critique the former “cultural dictatorship” of the Gang of Four, and the content of the play itself. In particular, Galileo's complexity as a character and the underlying message that “in order to be a socially responsible scientist, one requires not only stamina in the realm of science but also courage in destroying superstitions about the power of authority and in breaking through all kinds of restricted area.”¹⁶ Set designer Xue Dianjie 薛殿傑 attempted a melding of aesthetics drawn from Brecht's production notes for *The Life of Galileo* and from the conventions of *jingju*, such as level illumination of the stage, the abandonment of illusionism and painted backdrops, and the projection of thematic subtitles on a curtain between scenes.¹⁷ Both the content of the play and its staging generated a good deal of discussion within theater circles

Guizhou renmin chubanshe, 1984); Quanguo wutai meishu zhanlanhui 全國舞台美術展覽會, ed., *Zhongguo wutai meishu* 《中國舞台美術》 (Beijing: Zhongguo xiju chubanshe, 1986); Gong Hede 龔和德, *Wutai meishu yanjiu* 《舞台美術研究》 (Beijing: Zhongguo xiju chubanshe, 1987).

¹⁵ *The Life of Galileo* has the distinction of being the first foreign play performed by the Chinese Youth Arts Theater after the fall of the Gang of Four. Chen Yong, “The Beijing Production of Life of Galileo,” in *Brecht and East Asian Theatre: The Proceedings of a Conference on Brecht in East Asian Theatre*, ed. Antony Tatlow and Tak-Wai Wong (Hong Kong: Hong Kong University Press, 1982), 89. For further discussion of the production and its significance, see also Chen, *Occidentalism*, 53–58.

¹⁶ Chen Yong, “The Beijing Production of Life of Galileo,” 89–90.

¹⁷ Xue Dianjie, “Stage Design for Brecht's Life of Galileo,” in *Brecht and East Asian Theatre: The Proceedings of a Conference on Brecht in East Asian Theatre*, ed. Antony Tatlow and Tak-Wai Wong (Hong Kong: Hong Kong University Press, 1982), 80–83.

in Beijing and beyond; however, the production stopped short of attempting Brecht's more extreme suggestions for staging technologies, such as revealing the lighting equipment.

Another scientist play, entitled *Yuanzi yu aiqing* 《原子與愛情》 (Atomic Love, lit. “atoms and love”) and written by a group of actors in a military troupe, dealt more explicitly with both modern technology and modernized staging technologies.¹⁸ The play is structured with series of brief vignettes, set after the fall of the Gang of Four, that frame longer flashbacks to the early-to-mid 1960s. It tells the stories of two generations of scientists working to develop the first successful test of a nuclear missile in China, praising their patriotism while denouncing the setbacks to scientific research incurred the Cultural Revolution era. Critical response to the script was lukewarm, with more seasoned directors and playwrights applauding the actors for writing with attention to the potentials of staging but suggesting that the episodic structure left little time for character development. These same critics were more excited by the design choices made by the production, namely its innovative use of slide projections (*huandeng* 幻燈) to overlay the scenery with abstract designs, such as spider webbing during the Cultural Revolution scenes and images of handwritten mathematic formulas.¹⁹ In contrast to plays that attempted to use photorealistic projections as backdrops, *Atomic Love* was better able to exploit the “technical characteristics” (*jishu tedian* 技術特點) of projection, such as exaggeration, transformation, and abstraction. Xue Dianjie, the designer for *Galileo*, commented that these innovations in *Atomic*

¹⁸ The play was collaboratively written by a team of several actors-turned-playwrights, Li Weixin 李維新, Zeng Bangyu 鄭邦玉, Li Yonggui 李永貴, and Zhou Liguó 周立國, and produced by the People's Liberation Army General Political Huaju Troupe (Jiefangjun zongzheng huaju tuan 解放軍總政話劇團) in March 1980. It was published the following month along with the proceedings of a post-performance discussion group that included many of the major figures in Beijing theater. Li Weixin 李維新 et al., “Yuanzi yu Aiqing 《原子與愛情》,” *Juben* 《劇本》 4 (1980): 4–37; “Tansuo huaju yanchu de xin xingshi--Yuanzi yu Aiqing zuotanhui xiao ji 探索話劇演出的新形式——《原子與愛情》座談會小記,” *Renmin xiju* 《人民戲劇》 5 (1980): 15–17.

¹⁹ “Tanxuo Huaju Yanchu de Xin Xingshi.”

Love, though still in need of further development, went far to overcome what he called the problem of “duplication” (*leitong hua* 雷同化) in stage aesthetics.²⁰

Xue Dianjie’s comment reveals that, despite the fact that it was now several years post-*yangbanxi*, the problem of a too-uniform aesthetic on China’s mainstages persisted. To be sure, the problem had a history longer than ten years and reached beyond the genres of the stage *yangbanxi*, ballet and *jingju*. As we see from Xue Dianjie’s comment on *Atomic Love*, it was pervasive even in the *huaju* world, which had not even been directly involved in *yangbanxi* productions. At the same time, there were also rumblings of complaint in the opposite direction, with some critics voicing concerns about the negative effects of *too* much diversification onstage. Writing about a national scenography exhibition held at the National Art Museum (Zhongguo meishu guan 中國美術館) in Beijing, for example, Wang Ren 王韜 and Huang Su 黃甦 simultaneously praise the innovative spirit of scenic design and caution against it, writing:

Another hallmark of the development of scenographic creative work has been the continuous introduction of new successes in science and technology. For the past thirty years, a number of new equipment, new techniques, and new materials have been continuously strengthened and heightened the expressive means and artistic quality of scenography.

舞美創作發展的另一個重要標誌，是不斷引進了科學技術的新成果。三十多年來，許多新器材，新技術和新材料不斷增強和提高著舞美的表現手段和藝術質量。²¹

Wang and Huang go on to describe several of these innovations, including the use of projections and lighting effects, but also express concern that the application of such technologies is pure

²⁰ The full phrase that Xue Dianjie uses is “duplication in scenographic creation and in staging” (*wutai meishu chuangzuo he yanchu xingshi shang de leitong hua* 舞台美術創作和演出形式上的雷同化). *Ibid.*, 16.

²¹ Wang Ren 王韜 and Huang Su 黃甦, “Wutai meishu: zai tansuo yu chuangzuo zhong qianjin 舞台美術：在探索與創造中前進,” *Renmin xiju* 《人民戲劇》 1 (1983): 6.

spectacle—as they put it, “curiosity for the sake of curiosity” (*wei qi er qi* 為奇而奇).²²

Similarly, prominent director Xu Xiaozhong, writing in 1982, complains that technology has become a crutch for poor technique:

In the creative work of the huaju director, we generally have not paid enough attention to how to emphasize the technical brilliance of an actor’s performance or to give play to the charisma of a living art form...Directors often use visual and aural artistic tricks to bury the actor’s performance. Actors are ‘buried up to the teeth’ in human technologies, like thick makeup, microphones (even miniature microphones that they wear on their bodies).

在話劇導演創作中，如何重視演員的具有精湛技巧的表演，發揮活人藝術的魅力，還沒有收到普遍的重視...導演常常用種種視覺，聽覺的藝術手段淹沒演員的表演，演員被人用技術‘武裝到牙齒’，比如濃妝，比如麥克風（以致隨身佩帶微型話筒）。²³

From these comments, we can see a set of competing impulses at work in the theater world. On the one hand, there was a desire to align the historical narrative of technical theater, especially scenography, with the ethos of techno-scientific innovation that was officially promoted in the New Era. On the other hand, there is the sense that technologies of the stage, even traditional ones like makeup, could obscure the actor’s performance. This caution against *technology* is then paired with a call for greater attention to *technique*.

Rehabilitating the Actor’s Preparations

Although Xu Xiaozhong bemoans a lack of attention to acting craft on the part of directors, the issue of technique in general, and acting technique in particular, had arisen almost immediately after the end of the Cultural Revolution in 1976. Theater academies that had been

²² Ibid., 5.

²³ Xu Xiaozhong 徐曉鍾, “Ba ziji de xingshi fuyu ziji de guannian 把自己的形式賦予自己的觀念,” in *Xu Xiaozhong daoyan yishu yanjiu* 《徐曉鍾導演藝術研究》, ed. Lin Yinyu 林蔭宇 (Beijing: Zhongguo xiju chubanshe, 1991), 384.

closed or forced to shifted focus to ideological instruction during the Cultural Revolution faced the challenge of restarting their regular programs of study. Theater troupes that had been partially or fully disbanded were reformed, but members sent to the countryside for “socialist education” had not performed in a full production for years and some former luminaries were tragically never to return at all. After Jiang Qing and her *yangbanxi* had been denounced in the pages of theater journals and as the rusty institutional infrastructure for professional theater performance restarted, practical questions of performance became quite pressing.

One of the first places these concerns surface was in discussions of the rehabilitation of Stanislavsky. Prior to the Cultural Revolution, the Stanislavski system had been the foundation for huaju actor technique and training, and by most estimates the vast majority of huaju productions during the pre-Cultural Revolution Mao era had been in a Stanislavskian mode.²⁴ However, Stanislavsky fell out of favor with the Sino-Soviet split and in 1969 was roundly criticized for being a “petty bourgeois reactionary artistic ‘authority’” (*zichan jieji fandong yishu “quanwei”* 資產階級反動藝術“權威”) and for the individualistic foundations of his acting method (termed “starting from the self” *cong ziwo chufa* 從自我出發).²⁵ As scholars have noted, some concepts derived from his work in fact strongly influenced the development of the

²⁴ Scenic designer Xue Dianjie cites a source called *Introduction to Directing* by one G.N. Gur'yev (Guriev) as one of the few directing texts available and therefore was incredibly influential for both directing and scenic design (Xue “Stage Design for Brecht’s *Life of Galileo*,” *Brecht and East Asian Theatre*, 74). BPAT director Jiao Juyin 焦菊隱 is know for developing a distinct system of directing that was based on the Stanislavsky system, but incorporated acting techniques and aesthetic principles derived from Chinese *xiqu*. Jiao was persecuted and died during the Cultural Revolution. Essays on his theory and practice are collected in *Daoyan de yishu chuangzao* 《導演的藝術創造》 (Beijing: Wenhua shenghuo chubanshe, 1953); *Jiao Juyin xiju lunwenji* 《焦菊隱戲劇論文集》 (Shanghai: Shanghai wenyi chubanshe, 1979); *Jiao Juyin wenji* 《焦菊隱文集》 (Beijing: Wenhua yishu chubanshe, 1988). In English, see “A Chinese Director’s Theory of Performance: On Jiao Juyin’s System of Directing,” *Asian Theatre Journal* 20, no. 1 (2003): 25–42.

²⁵ Originally published in *Hongqi* 《紅旗》 6-7 (1969). Shanghai geming da pipan xizuo xiaozu 上海革命大批判寫作小組, “Ping Sitannisilafusiji tixi 評斯坦尼斯拉夫斯基‘體系’,” *Renmin ribao* 《人民日報》, July 16, 1989.

yangbanxi, especially in relation to the “modernization” of *jingju*, but after 1969, he was officially anathema.²⁶

In 1978, the faculty of the Shanghai Theater Academy took up the tasks of re-evaluating Stanislavki’s acting and directing methods in relation to Chinese theater and answering the criticisms leveled against them during the Cultural Revolution. A conference was held in early 1978 and a report on its proceedings published in the academic journal published by STA, *Xiju yishu* 《戲劇藝術》 (Theater Arts).²⁷ In fact, the faculty participating in the conference did not wholly repudiate the repudiation of Stanislavsky. While they critiqued the earlier wholesale rejection of Stanislavski, they actually seemed to agree that, due to the historical and political circumstances under which Stanislavki’s theories were developed, there were some elements that did not perfectly align with Marxist-Leninist-Mao Zedong thought. However, they also insisted upon Stanislavsky’s status as a “realist theater revolutionary,” and several made arguments for the continued utility of his acting method. One particularly loquacious speaker, director Chen Mingzheng 陳明正 (b. 1931), discussed the problem of the self in relation to role creation at some length. In essence, he argued that the original criticism of “starting from the self” in 1969 had been rooted in a misunderstanding of the technique; it was not a marker of bourgeois individualism, but rather a shorthand for the actor’s process of taking on the thoughts and

²⁶ William Sun, “Mei Lanfang, Stanislavsky and Brecht on China’s Stage and Their Aesthetic Significance,” in *Drama in the People’s Republic of China*, ed. Constantine Tung and Colin Mackerras (Albany: State University of New York Press, 1987), 142.

²⁷ This was the inaugural issue of the journal *Theater Arts*, which began as a quarterly journal. It is now one of the leading academic theater publications in the PRC. Xiju yishu yanjiu shi 戲劇藝術研究室 and Biaoyan xi biaoyan jiaoyan zu 表演系表演教研組, “Guanyu Sitannisilafusiji tixi de taolun 關於斯坦尼斯拉夫斯基體系的討論,” *Xiju yishu* 《戲劇藝術》 1 (1978): 9–28.

feelings of her character.²⁸ Overall, there seemed to be agreement that the training methods developed by Stanislavski had value and could still be of use.

These conference proceedings begin with a boilerplate harangue against Jiang Qing and the Gang of Four, but as they proceed, much more specific critiques of their effect on huaju emerge. Repeatedly, the discussion of Stanislavskian acting technique and training segues into complaint about the general circumstances of technique and training during the Cultural Revolution. For instance, director and acting instructor Zhang Yingxiang 張應湘 (b. 1935) describes the unrealistic expectation of members of the Gang of Four opposed basic technical training and believed that students would be suited to performing “grand-scale productions” (*daxi* 大戲) as soon as they entered the Academy. As late as 1974, there were struggle sessions launched against teachers at STA who attempted to implement a training system for younger performers. Such vehement opposition to technical training works as a distillation of all that was wrong with the Cultural Revolution: privileging of chaos over order, blind repudiation of tried-and-true artistic methods, and punishment for expertise. Actors were not only robbed of opportunities to create interesting characters under the *yangbanxi* aesthetics of uniformity, but also of the tools they would need to do so—basic training in acting technique.²⁹ The irony was, of course, that the *yangbanxi* were highly technical pieces (as discussed in the Interlude). The cessation of training during the Cultural Revolution only provides further evidence of the self-sabotaging impulse underlying the entire *yangbanxi* project. Asked to perform the grandest of grand-scale productions without training, even aspiring professionals were doomed to failure.

²⁸ Ibid., 23.

²⁹ The first issue of *Theater Arts* also carries a letter from an alumnus and actor in the Shanghai Huaju Troupe (Shanghai huaju tuan 上海話劇團), Zhang Xianheng 張先衡 (b. 1936), advocating basic actor training. Zhang Xianheng 張先衡, “Yao zhuahao jibengong xunlian 要抓好基本功訓練,” *Xiju yishu* 《戲劇藝術》 1 (1978): 159–61.

Following the 1978 conference on Stanislavski, STA faculty members immediately took up the charge to reform the training system for huaju actors. In the very next issue of *Theater Arts*, a group of acting instructors published the introduction to a series of articles on physical training methods that would be published over the course of the following year.³⁰ The articles are themselves quite technical, but a number of important theoretical points are stated explicitly in their preface and emerge from the lists of exercises. Notably, the authors dismiss any notion that “spoken” drama actors should focus purely on text and voice, and make a strong claim for the importance of systematic physical training. Surveying the history of actor training in the PRC, they note that huaju actors in earlier periods had received limited classes in ballet, *xiqu*, and stage movement from foreign and Chinese experts, but that too often these courses did not properly account for how the skills of the “sister arts” (*jiemei yishu* 姐妹藝術) ought be adapted to the particular needs of huaju performance. In addition, in their suggestions for exercises, they divide skills into three categories: (1) basic training (*jigong* 基本功), (2) skills (*jineng* 技能), and (3) method (*jifa* 技法). The first category involved basic warm-up exercises designed to improve general strength and flexibility, whereas the second emphasized learning specific types of movement frequently used onstage, such as specific ways to fall down or how to hold and operate different weapons. (The third category is not discussed at length, but seems to indicate a method for applying general skills to particular circumstances.)

The schematic outline of basic training in these articles, especially in their free appropriation of techniques, like bar work, from various “sister arts,” calls to mind the strict

³⁰ Liu Zhifen 劉芷芬 et al., “Huaju yanyuan xingti xunlian (xuyan) 話劇演員形體訓練 (序言),” *Xiju yishu* 《戲劇藝術》 2 (1978): 52–57; “Huaju yanyuan yanyuan xingti xunlian (yi) jigong 話劇演員形體訓練 (一) 基本功,” *Xiju yishu* 《戲劇藝術》 3 (1978): 51–65; “Huaju yanyuan xingti xunlian (er) wutai jineng 話劇演員形體訓練: (二) 舞台技能,” *Xiju yishu* 《戲劇藝術》 1 (1979): 100–102; “Huaju yanyuan xingti xunlian (xu) 話劇演員形體訓練(續),” *Xiju yishu* 《戲劇藝術》 2 (1979): 106–9.

training programs required for the study of Chinese *xiqu* forms, acrobatics, and Western ballet. However, the architects of this huaju training program are adamant in the medium specificity of their schema. While they do advocate borrowing individual exercises or patterns of movement from other performing arts, they strongly decry the mechanistic importation of entire training systems and the conventionalization (*chengshihua* 程式化) of forms like *jingju* and *kunqu*. Instead, through training, the body is to be reconfigured as a “highly dynamic and efficient tool for artistic creativity (*feichang jiji you xiao de chuangzao gongzu* 非常積極有效的創造工具)”.³¹ The overarching conceit furthermore is one of the actor as a *designer* who, once provided with the properly trained body and a toolkit of techniques and methods, will be able to give full expression to any character in any script. This process is articulated in a set of phrases repeated several times throughout these articles: design, organize, embody (*sheji* 設計, *zuzhi* 組織, *tixian* 體現). This is in and of itself a highly technical—or, to use the authors’ ideologically correct phrasing, a highly “scientific” (*kexue* 科學)—concept of the actor’s task.

It was also at the Shanghai Theater Academy (Shanghai *xiju xueyuan* 上海戲劇學院), or STA, that Chinese theater artists began experimenting with more radical forms of actor training, namely the theories of Polish director Jerzy Grotowski. Grotowski himself had visited China in 1962, but his work does not seem to have been introduced until the early 1980s. The periodical *Waiguo xiju* 《外國戲劇》 (Foreign Drama) published a translation of his interview with Eugenio Barba, “The Theatre’s New Testament,” in April 1980, and excerpts from *Towards a Poor Theater* appeared in *Theater Arts* in 1982 as part of a section introducing Grotowski along

³¹ Liu Zhifen et al., “Huaju yanyuan xingti xunlian (xuyan),” 56.

with Antonin Artaud and Peter Brook.³² Director Huang Zuolin 黃佐臨 (1906-1994) also gave lectures on Grotowski's theories at STA and the Shanghai People's Art Theater (Shanghai renmin yishu juyuan 上海人民藝術劇院), or SPAT, which were then reprinted as a preface to a full translation of *Towards a Poor Theater* that was published in 1984.³³ Danni 丹尼 (Jin Yunzhi 金韻之, 1912-1995) renowned actress and Huang's wife, contributed by orally translating the sections on "Actor's Training (1959-1962)," recorded by Barba, and "Actor's Training (1966)," recorded by Franz Marijnen; these abbreviated translations were also published in *Theater Arts* in 1981.³⁴

In July 1981, actors from STA and SPAT formed a working group dedicated to following the exercises outlined in the two essays on "Actor's Training" from *Towards a Poor Theater*. For two months, they met daily for about an hour and worked through several sections of the essays as translated by Danni. One participant, actress Wei Shuxian 魏淑嫻, then published a response to their training experiment in *Theatre Arts*, alongside transcripts of Danni's translation of the original (translated) essays.³⁵ In her response, Wei describes a number

³² The translated excerpts are "The Actor's Technique," an interview with Denis Bablet, and "Statement of Principles," originally published in *Wenyi yanjiu* 《文藝研究》 02 (1985) and cited in Lin Kehuan 林克歡, "Yanyuan yu guanzhong 演員與觀眾," in *Xijuguan zhengming ji* 《戲劇觀爭鳴集》 (Beijing: Zhongguo xiju chubanshe, 1986), 255. 耶士·格洛托夫斯基 (Jerzy Grotowski), "Puzhi xiju yu leixiju lilun xuan yi '質樸戲劇' 與 '類戲劇' 理論選擇," trans. Mao Baiyu 矛百玉, *Xiju yishu* 《戲劇藝術》 4 (1982): 91-101. See also Huang Zuolin 黃佐臨, "Zhenme jiao 'qionggan xiju' 什麼叫'窮干戲劇,'" *Waiguo xiju* 《外國戲劇》 1 (1982): 52-53; Jerzy Grotowski, *Towards a Poor Theatre*. (New York, Simon and Schuster, 1968).

³³ In the early-to-mid 1980s, "poor theater" was translated inconsistently as *zhipu xiju* 質樸戲劇, *pinkun xiju* 貧困戲劇, and *qionggan xiju* 窮干戲劇. The first of these was used for the complete translation. 耶士·格洛托夫斯基 (Jerzy Grotowski), *Maixiang zhipu* 《邁向質樸戲劇》, trans. Wei Shi 魏時 (Beijing: Zhongguo xiju chubanshe, 1984).

³⁴ 格洛托夫斯基 (Grotowski), "Yanyuan jibengong xunlian 演員基本功訓練," trans. Danni 丹尼 and Huang Haiqin 黃海芹, *Xiju yishu* 《戲劇藝術》 4 (1981): 7-20.

³⁵ Wei Shuxian 魏淑嫻, "Yici changshi 一次嘗試," *Xiju yishu* 《戲劇藝術》 4 (1981): 21-22.

of exercises that will be familiar to readers of *Towards a Poor Theatre*, such as the imitation of a cat stretching and a flower blossoming, and summarizes the principles learned through even this brief attempt at Grotowskian technique: First, that the training required them to free their bodies, especially from feelings of unwieldiness or reservation. Second, that the training required full concentration of the mind and body, working together to perform. Third, that as the tool of the actor, the body needs to be plastic and expressive, and fourth, that the expression of emotion must permeate the entire body. Throughout Wei's interpretation of Grotowskian training, we find a clear continuation of the technical approach to acting articulated in earlier discussions of huaju acting technique, but an even stronger emphasis on drawing a distinction from (what Wei sees as) the repetitive and mechanical movements of dance and calisthenics. Instead, the focus lies on developing a level of dexterity and attentiveness that will enable the actor to control and create the subtle movements that accompany the expression of genuine emotion.

The dialectic of control and freedom at work in these discussions of actor training and technique might be read not as a rehabilitation of Stanislavski in particular, but rather a broader rehabilitation of the acting body. With the narrowing of all ideologically sanctioned performance to the *yangbanxi*, the definition of what constituted an ideal performer likewise narrowed to those who could perform the requisite *jingju* martial flips and balletic *grands jetés*, and implicitly denouncing those who could not. The *yangbanxi* had been, in effect, the epitome of what Emily Wilcox has identified as a “cult of virtuosity” in socialist China. Relating dancers in the PRC to the Soviet Ideal of the “New Man,” Wilcox argues that dancers were uniquely able to define themselves as model citizens in a society wherein “demonstrations of exceptional physical ability came to identify people as good socialist subjects.”³⁶ For dancers, ability was demonstrated

³⁶ Emily Wilcox, “The Dialectics of Virtuosity: Dance in the People's Republic of China, 1949–2009” (PhD Dissertation, University of California-Berkeley, 2011), 20, <http://search.proquest.com/docview/896622153/>.

especially through *jiqiao*, which Wilcox translates as “technique tricks”:

Physical abilities developed through strict training become, for most dancers, an important source of pride, as well as a measurement of success and even self-worth. Leg stretches like the ones described at the beginning of this chapter, along with high difficulty flips, turns, and jumps, make up collectively what are known as “technique tricks” (*jiqiao* 技巧), the ultimate measure of the dancer’s ability.³⁷

As Wilcox highlights throughout her work, the issue of technique is also an issue of body politics. Speaking in relation contemporary Chinese visual and performance art, critic and artist Zhang Hong makes a similar but more sweeping claim:

Using a series of techniques to control the body, revolutionary ideology remoulded the image of the modern Chinese revolutionary body and at the same time declared the individual body to be the nation’s eminent domain... Shaping images of workers, peasants and soldiers became the main basis for the revolutionary transformation of the body... this ‘model’ body appears in an even more exaggerated form in the ‘model’ artworks for the Cultural Revolution.³⁸

In the post-Cultural Revolution era, one question for performers therefore became: how to reclaim the disciplined, socialist artist’s body? The discussions published in *Theater Arts* seem to suggest that to recover fully from the trauma of this revolutionary remolding, reclaiming artistic freedom was not enough. Rather, they posit a decoupling of the practical necessity of training from its association with ideological discipline in a way that returns the means of artistic production to artists on multiple levels.

In these discussions of and experiments with actor training, we thus find a developing concept of the *huaju* actor as a virtuosic *and* versatile performer—one for whom rigorous physical training in a variety of techniques paradoxically frees him or her to achieve greater heights of creative expression. Catholically combining concepts from Stanislavski, Grotowski,

³⁷ Ibid., 12.

³⁸ Zhang Hong, “Fragments of the Body in Chinese Contemporary Art,” in *The Body at Stake: Experiments in Chinese Contemporary Art and Theatre*, ed. Jörg Huber and Chuan Zhao (Bielefeld: Transcript, 2013), 29, 33.

dance, and *xiqu*, this ideal actor can flexibly move among gestures drawn from the “sister arts,” without falling prey to their perceived flaws of rigidity and conventionality. In turn, his or her body itself functions as a medium for the transmission of life-like emotion. In other words, the actor’s body becomes medium in multiple ways. It is this concept of the multimedial actor, I will argue, that we find being explored and put on display in a number of productions in the 1980s, beginning with *The Red Nose*.

Technique and Technology in The Red Nose

For director Chen Yong, the exploration of new acting technique was occasioned in a rather unusual way: when she traveled to Hong Kong in 1981 for a conference on Bertolt Brecht and discovered the collections of two Taiwanese playwrights, Yao Yi-wei and Zhang Xiaofeng 張曉風 (b. 1941).³⁹ She found herself especially captivated by Yao’s story of a group of travelers trapped by inclement weather in a seaside hotel in Taiwan. At the time, what is in fact a classic dramatic scenario—using an external force (the storm) to thrust characters into improbable, yet ultimately meaningful, interactions—felt new and refreshing. *The Red Nose* offered a further point of attraction in its representation of a veritable microcosm of Taiwanese society, with its characters including a middle-class couple vacationing with their daughter, a wealthy businessman, a frustrated composer, and a couple of failing small-time manufacturers.

³⁹ As mentioned above, Chen Yong also co-directed *The Life of Galileo* in 1979. Chen began her career performing in propaganda troupes during the Civil War, and received formal training at the Central Drama Academy and in Moscow at the Lunacharski State Institute for Theater Arts (now, the Russian University of Theater Arts, or GITIS). In China, she is widely regarded as one of the preeminent *huaju* directors of the latter half of the 20th century, yet she is rarely given due credit in English-language scholarship. Chen Yong 陳顥, “Wei zaori shixian zuguo tongyi daye gongxian liliang—Hong bizi paiyan suibi 為早日實現祖國統一大業貢獻力量,” *Yingju meishu* 《影劇美術》 4 (1982): 2–3. For more extensive discussions of Chen’s life and work, see Liu Liexiong 劉烈雄, *Zhongguo shida xiju daoyan dashi* 《中國十大戲劇導演大師》 (Beijing: Zhongguo renmin daxue chubanshe, 2005); Gu Chunfang 顧春芳, *Tade wutai: Zhongguo xiju nü daoyan chuanguo yanjiu* 《她的舞台：中國戲劇女導演創作研究》 (Shanghai: Yuandong chubanshe, 2011).

The arrival of a variety show troupe in need of shelter from the storm enlivens the scenario, and their main act—a clown referred to as Hongbizi 紅鼻子 (“Red Nose”)—creates almost magical connections with several of the hotel’s occupants.⁴⁰ The play is driven by character development, with interactions among the different personages motivating moments of self-realization. The most significant of these takes place when a woman named Wang Peipei 王佩佩 appears at the hotel and reveals herself to be the wife of “Red Nose,” whose proper name is Shenci 神賜. Wang Peipei attempts to convince her husband to return home to her, but he insists on his need to pursue personal happiness, which he defines as rooted in self-sacrifice. In keeping with this philosophy, he ends the play by drowning in an attempt to save another of the variety show troupe members, who disappeared while out for a swim.⁴¹

The publication and production of *The Red Nose*, while hardly a play about a scientist, was in its own way symptomatic of the “opening up” of the PRC that occurred in the 1980s. As noted in the introduction to this chapter, the production by the China Youth Arts Theater in February 1982 marked the first time that a play from Taiwan had been produced in mainland China since their division in 1949. There had been little interaction between the people of the PRC and Taiwan since the KMT retreat to Taiwan in 1949, and many families had had little or no news of relatives on the opposite site of the Taiwan Strait for decades. Articles written in

⁴⁰ A note on translation: the term used for the performers is *zashua banzi* 雜耍班子, which dictionaries typically render as “variety show,” “vaudeville,” or “sideshow.” “Variety show,” despite its association with later trends in Asian television programming, seems to best describe the particular array of entertainments that this particular troupe offers. In contrast, “vaudeville” carries too specific a connotation vis-à-vis American theater (i.e. the type of vaudeville with which most of my readership will be most familiar) and “sideshow” too close an association with the American big-top circus or traveling carnival.

⁴¹ Yao Yiwei 姚一葦, “Hong bizi 《紅鼻子》,” *Juben* 《劇本》 2 (1982): 46–82. Also in Yao Yiwei 姚一葦, *Yao Yiwei xiju liuzhong* 《姚一葦劇作六種》 (Taipei: Shulin chuban youxian gongsi, 2000). For an English translation, see Ying-Chu Yeh, “A Translation of and Commentary on Red Nose (Hung Pi Tzu) - a Four-Act Play by Yao Yi-Wei (1922-)” (Iowa State University, 1981).

response to the play's publication and performance praise Yao Yi-wei's play for offering these curious audiences a window into contemporary life in Taiwan, which otherwise remained an ideologically shrouded mystery.⁴² These articles also inevitably included information on the playwright's biography, namely that he had traveled to Taiwan for work *before* 1949 and had been unable to return after the end of the civil war in 1949. He was thereby cleared of any political disrepute, and consanguineous connections between Taiwan and mainland China were further highlighted by the publication of letters from Yao Yi-wei's mother and brother, both of whom still lived on the mainland.

In addition, the play's depiction of characters dissatisfied with their place in this society or who felt estranged from it, called into question the effects of modernization and marketization in a way that resonated with PRC audiences and politics alike. An extreme of this interpretation is articulated by prominent theater critic and director Lin Kehuan 林克歡 when he writes of the world depicted in *The Red Nose*:

This is a cold society that doesn't need beauty, that can't encompass beauty. The society not only distorts the life of young Ye Xiaozhen, it also swallows up the kind-hearted, high-minded "Red Nose." The sublime of his tragic sacrifice leaves readers and audiences with an unusually bitter taste. This is a most distressed critique of the realities of Taiwanese society, even of all of capitalist society today.

這是一個不需要美，也不容納美的冷酷社會。這個社會不但扭曲了葉小珍年幼的生命，也吞噬了善良，崇高的紅鼻子。悲劇犧牲的崇高，在讀者和觀眾心中留下的卻是一般異常苦澀的味道。這是作者對台灣現實社會，甚至是對整個當代資本主義社會最痛心的批判。⁴³

⁴² Li Ke 里克, "Hong bizi ji qi zuozhe Yao Yiwei 《紅鼻子》及其作者姚一葦," *Renmin ribao* 《人民日報》, March 7, 1982; Wu Yingfu 吳英輔, "Taiwan shehui de zhongshengxiang--Hong bizi guanhou gan 台灣社會的眾生相——《紅鼻子》觀後感," *Renmin ribao* 《人民日報》, March 19, 1982.

⁴³ Lin Kehuan 林克歡, "Yao Yiwei he tade Hong bizi 姚一葦和他的《紅鼻子》," in *Hong bizi de wutai yishu* 《〈紅鼻子〉的舞台藝術》, ed. Lin Kehuan 林克歡 (Beijing: Zhongguo xiju chubanshe, 1984), 272.; Lin Kehuan published a similar article along with the script of *The Red Nose* in 1982: Lin Kehuan 林克歡, "Yao Yiwei xiansheng he tade Hong bizi 姚一葦先生和他的《紅鼻子》," *Juben* 《劇本》 2 (1982): 82–84.

Lin Kehuan's reading of the play is not entirely unfounded, but in the context of the PRC, it implies an ideological valence that is not present in Yao Yi-wei's work. *The Red Nose* is indeed critical of contemporary Taiwanese society and the corruption, disenfranchisement, and shallowness brought by modernization and commercialization. However, the play frames its critique with existential questions in a pop-psychological mode—how to live a meaningful life? how to find happiness?—that hardly suggest a Marxian critique. Inaccurate though it may be, Lin's interpretation helps to discursively align the play with contemporary PRC ideology in a way that made a potentially problematic work politically correct.

According to Chen Yong, introducing audiences to life in Taiwan was indeed one goal of the Youth Arts production in 1982. However, in the director's notes published in *The Stage Art of The Red Nose*, she seems far more excited by the artistic potential of the play. In a record of her conversations with the cast and creative team, Chen applauds the play for its innovative style and dramaturgical structure, which render it ripe for creative exploration—and, as we will see, experiments in acting technique:

This play is not suited to the kind of performance method generally used in the past. In its staging, I intend to use a multimedial performance style and to make use of a number of different staging techniques in order to highlight the ideological content and philosophy of the play.

這個戲不宜象過去一般的演法，在舞台處理上我想運用多媒介的演出形式，利用多種舞台手段，來突出戲的思想性和哲理性。⁴⁴

There were two particular aspects of the text that necessitated this approach.⁴⁵ First, as mentioned above, the play is character-driven, and what little action there is takes place in a

⁴⁴ Chen Yong 陳顥, "Daoyan tanhua lu 導演談話錄 (Director's Notes)," in *Hong bizi de wutai yishu* 《〈紅鼻子〉的舞台藝術》, ed. Lin Kehuan 林克欢 (Beijing: Zhongguo xiju chubanshe, 1984), 32.

location suspended in space and time. The hotel's name is "Penglai 蓬萊" and its reference to the legendary island of immortals draws attention to the already liminal nature of any temporary lodging and to the uneasy political geography of Taiwan. Beyond this, the playwright places his characters into a state of forced immobility by conjuring a storm that causes a mudslide and halts traffic moving north. They are stuck in the hotel, unable to travel on or return home, as the case may be. The Penglai Hotel becomes a doubly or triply liminal space. The central challenge for scenography, then, is to represent both the physical reality of the hotel lobby—set in contemporary Taiwan, filled with characters from all walks of Taiwanese life—and its no-space-ness. This task is further complicated by the fact that the structure of the play requires the playing space to be quite fluid; the play's moves among number of loosely related conversations involving different sets of characters—what set designer Mao Jingang 毛金鋼 refers to, with a term that nods to physics, as the play's "shifting gravitational center (*zhongxin de liudongxing* 重心的流動性)"—and in the third act, the variety show troupe turns the hotel lobby into a stage for their performance.⁴⁶ Accordingly, Mao Jingang designed an abstracted set segmented into discreet but connected spaces. Stage right, a staircase connects two octagonal platforms and leads offstage. Stage right, a bar and a sofa set the limits of the playing space. An additional sofa and five sets of table-and-chairs dot the stage, but do not clutter it. Thin strips of taut material hang upstage in place of a full-stage backdrop, creating a sense of openness and lending the space a feeling of indeterminacy. [Figure 27]

⁴⁵ In her *daoyan gousi* 導演構思 (director's treatment), Chen Yong discusses at length her interpretation of the play and its characters. Here, I focus on her comments on plans for staging and the sections of her treatment that are most directly related to the concept of a "multimedial staging."

⁴⁶ Mao Jingang 毛金鋼, "Yanchu xingshi tezheng de tansuo--wutai meishu sheji tihui 演出形式特徵的探索——舞台美術設計體會," in *Hong bizi de wutai yishu* 《〈紅鼻子〉的舞台藝術》, ed. Lin Kehuan 林克欢 (Beijing: Zhongguo xiju chubanshe, 1984), 251.

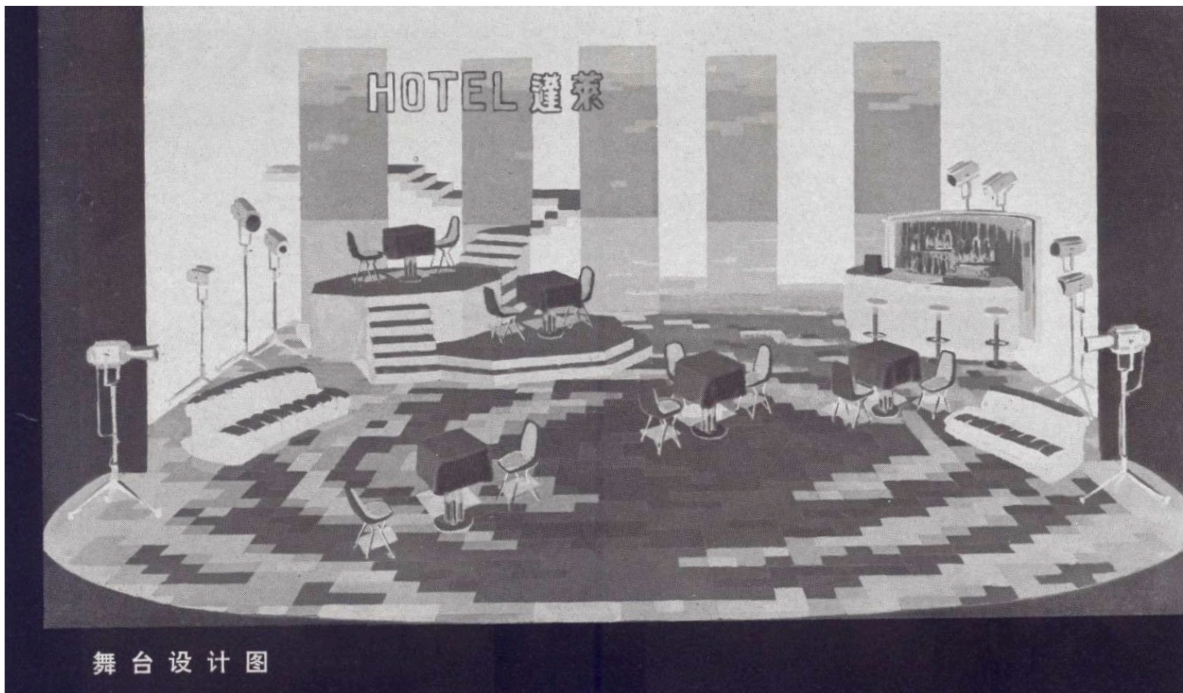

Figure 27 Set design for Youth Arts Production of *The Red Nose*, 1982 (Source: front matter, *Hong bizi de wutai yishu*, 1984)

from scratch. As she remarks in her director’s treatment: “I was determined to display onstage the superior skills and technique of huaju actors, so the whole rehearsal process started from technical training.”⁴⁸ To this end, they began the rehearsal process with six weeks of training in modern dance, acrobatics, and various musical instruments.⁴⁹ The actors also did physical exercises (*xingtǐ xunliàn* 形體訓練) daily and learned to relax their bodies in order to better create the physicalities of each individual character.⁵⁰ The latter, especially, seems to follow classic Stanislavskian technique. Yet, for many of the actors in the cast, this was the first time

⁴⁷ Chen Yong, “Daoyan Tanhua Lu,” 1984, 33.

⁴⁸ “我決心要在舞台上展現話劇演員資深的真功夫和技巧，因此整個排練將從技巧訓練入手。” Chen Yong 陳顥, “Daoyan gousi 導演構思,” in *Hong bizi de wutai yishu* 《〈紅鼻子〉的舞台藝術》, ed. Lin Kehuan 林克欢 (Beijing: Zhongguo xiju chubanshe, 1984), 28.

⁴⁹ Chen Yong 陳顥, “Wode zhuiqiu 我的追求,” in *Wode yishu wutai* 《我的藝術舞台》 (Beijing: Zhongguo xiju chubanshe, 1999), 340.. Originally published in *Xiju luncong* 《戲劇論叢》 7.3 (1982).

⁵⁰ Chen Yong, “Daoyan tanhua lu,” 1984, 32–33.

they had been introduced to the practice of creating a character “from the outside in” (*wai dao nei* 外到內)—beginning from physical characteristics and working inward toward psychology—despite their ostensibly Stanislavskian training.

The fundamental requirement for a variety of techniques onstage may be occasioned by Yao Yiwei’s script, but the engagement with physical training that emerged through the rehearsal process went far beyond the superficial grafting of one performance form onto another. In fact, the rehearsal room seems to have functioned as a testing ground for exploring concepts of the ideal, multimedial actor strikingly similar to those that had been discussed and described in *Theater Arts*. Chen states her vision of the ideal actor quite explicitly: “In addition to the fundamentals of dialogue, physicality, etc., I think that huaju actors should have a grasp of techniques from multiple arts.”⁵¹ In her rehearsal process, she worked to build these skills in her actors. However, she also applied physical training in much more innovative ways. Lead actor Feng Fusheng 馮福生 relates one particularly interesting anecdote in an essay about his role as the titular character “Red Nose.” After struggling for a time with the role and still unable to get into character, he found himself confronted with an unusual request from his director:

One time quite randomly, we were rehearsing acrobatics in the rehearsal room, and director Chen Yong out-of-the-blue asked me to follow along to some vocal cues and act out different animals. At once, I got really embarrassed, but it was as if the whole room of actors had discussed the matter with the director already, and they all started cheering. All the blood rushed to my face and my whole body felt as if it were bound up in chains, unable to move at all or get around the obstacles [in front of me]. I started to squirm, not wanting to do anything at all; then I braced myself...this kind of extremely passive performance would definitely be unwatchable. I really was on the verge of tears. But the director was adamant, and my colleagues started clapping even louder and cheering like crazy. I wished that there was a little crack in the ground that I could bore into. But there was nothing to be done, I had to get out there. So I clenched my teeth, and followed the sounds and rhythms. So then I was performing a cow, then playing a chicken, for a

⁵¹ “我想，話劇演員除了要有最基本的台詞，形體等功底外，還需要掌握多種藝術手段。” Chen Yong, “Daoyan tanhua lu,” 33.

moment a pig and another moment a duck...this endless menagerie made the whole room burst out in laughter. The funny thing was, in that moment, I felt that I wasn't myself. I was liberated. I could transform on command, smoothly shift my own rhythm. I could express my own passion and joy with ease—my god, I had found the feeling of the character 'Red Nose'!

一次偶然的機會，排練場上正在排雜技，陳顛導演即興地讓我隨著口技的變化而扮演各種動物。我一下子窘住了，而全場的演員都象和導演事先商量好似的，一起鼓起掌來。我全身的血一下子痛到臉上，渾身象有無數鎖鏈網綁，一下也動不了，一步也邁不開。我開始扭扭捏捏，怎麼也不敢；繼而硬著頭皮學幾下，當然，這種及其被動的表演是在讓人看不下去，我都快哭出聲來了。可是導演卻無動於衷，同志們鼓掌更加強烈，叫聲越發狂熱，我恨不得有條地縫可以鑽進去。沒辦法，只好割出去了，我咬咬牙，隨著口技的不同內容和節奏變化，我從而表演牛，從而扮作雞，一會兒趕豬。一會兒促鴨...這無窮無盡的動物園馬拉松競賽，逗得全場的同志哈哈大笑。說也奇怪，剎那間，我覺得我不是自己了，我解脫了，我能夠隨著號令的變化，迅速地改變自己的節奏了，我也能夠自如地表達自己的熱情和快樂了——天哪，紅鼻子的感覺我找到了！⁵²

How eccentric the training exercise seemed is clear from Feng's strong—and colorfully wrought—response to it. He generalizes and projects into the future, fearing that the process would generate an “unwatchable” performance. What seems to trouble him most is not the ignominy of playing a chicken per se, but rather the implication that the exercise would make him a passive puppet of the director. In this particular worry, we can perhaps see the lingering traumas of the Cultural Revolution *yangbanxi* and their attempts at total control over actors' bodies. However, this was far from effect on the actor. Instead, he writes:

This chance discovery enlightened me to a fundamental principle: only by searching for (both) the proper psychological state and physical self-perception can one make the 'seed' of a character sprout, blossom, and bear fruit, and grasp the essence of the character and create a distinctive form for him.

...這次意外的收穫，使我悟到了一個道理：只有尋找到準確的人物心理，形體的自我感覺狀態，才能使創造角色形象的‘種子’萌芽，開花，結果，才能逐步地把握人物的內在實質，創造鮮明的人物形象。⁵³

⁵² Feng Fusheng 馮福生, “Rensheng de mianju 人生的面具,” in *Hong bizi de wutai yishu* 《〈紅鼻子〉的舞台藝術》, ed. Lin Kehuan 林克欢 (Beijing: Zhongguo xiju chubanshe, 1984), 198–199.

⁵³ *Ibid.*, 199.

Here, in almost religious terms, Feng describes a moment of enlightenment attained by first being placed in a state of extreme self-consciousness, then relinquishing the control of his conscious mind, and finally finding an intuitive sense of the character. Whereas his earlier preparations for the role had involved studying the script and trying to understand the psychology of the character, this new exercise succeeded through spontaneity and kinesthesia. It was, however, a spontaneous and kinesthetic experience made possible in the context of a strict physical training routine, and in this bears certain similarities to Grotowskian technique.

Both aspects of Feng's experience in rehearsal also, in turn, play a central role in realizing his role onstage. Of all the characters, his "Red Nose" is the most complex, and the most performative. When the variety troupe arrives at the hotel in the first act, for example, his antics are the center of their opening act. The hotel manager desperately wants them to leave, but instead, the troupe members burst into song and "Red Nose" playfully leads them around the lobby, from table to table. Later, when the troupe stages a more formal performance for the hotel's occupants, "Red Nose" once again takes the lead and plays emcee, announcing first a "technique performance" (*jiqiao biao'yan* 技巧表演) and then a "mysterious dance" (*shenmi wudao* 神秘舞蹈) before offering his own routine. According to the stage directions in the production script [Figure 28]:

"Red Nose" does a comic routine carrying a cup on his head.

The audience laughs heartily.

An actor starts to perform vocal cues. Following the calls of birds, and a chicken, "Red Nose" does a comic routine acting out all different kinds of animals. After the sound of a rooster, "Red Nose" takes an egg dyed red from behind his back—a rooster laying an egg!

The audience laughs.

[紅鼻子作頂杯子的滑稽表演。]

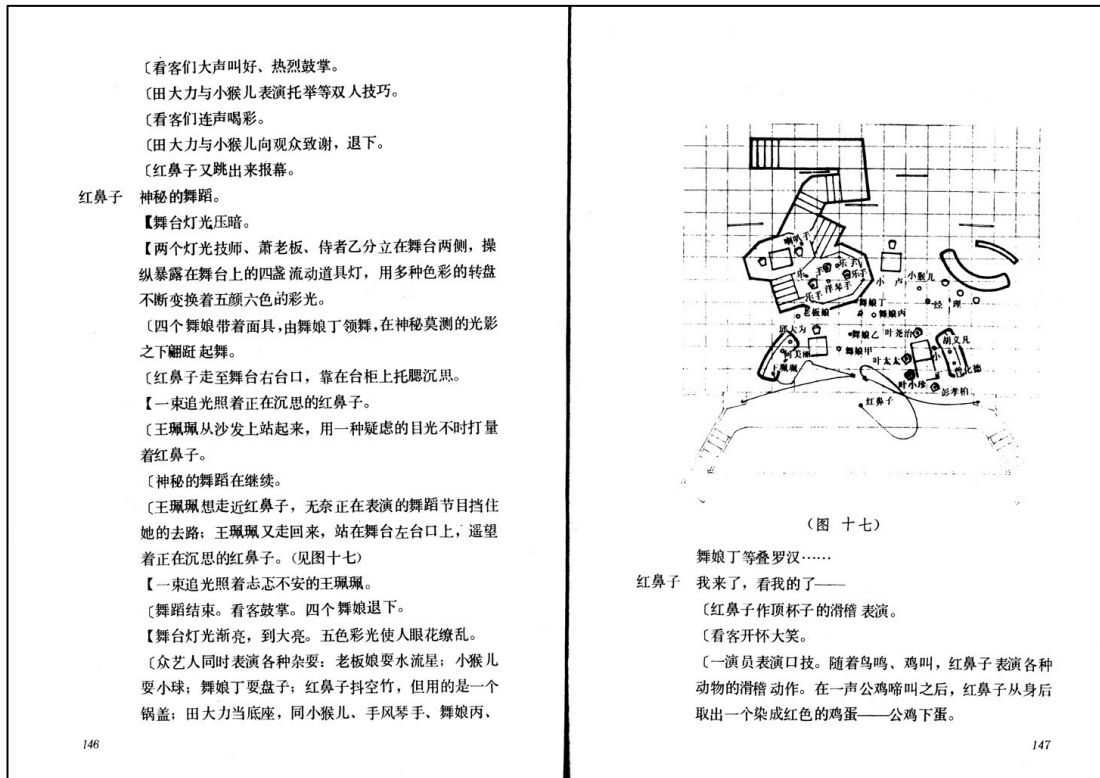

Figure 28 Blocking and stage directions for added scene in *The Red Nose*, 1982 (Source: *Hong bizi de wutai yishu*, 1982, 146-147)

[看客開懷大笑。

[一演員表演口技。隨著鳥鳴，雞鳴，紅鼻子表演各種動物的滑稽動作。在一聲公雞啼叫之後，紅鼻子從身後去處一個染成紅色的雞蛋——公雞下蛋

[看客大笑。⁵⁴

In this routine, Feng reenacts onstage the precise creative process that in rehearsal had led him to discover the essence of his character; here, the kinesthetic experience and spontaneous moment of humor, perhaps even of Bakhtinian “carnival laughter,” created in rehearsal is passed on first to the “audience” onstage, and then to the spectators offstage. It is furthermore a moment absent from Yao Yi-wei’s original script, which moves directly from the dancers’ “mysterious dance” to

⁵⁴ Quoted from the production script in *Hong bizi de wutai yishu*, 147-148

a song performed by Xiao Hu 小戶, one of the troupe's musicians.⁵⁵ Rather, it represents a conscious decision on the part of the director and actor to put on display a moment drawn from a training exercise than explicitly displays the actor's powers of physical transformation, to great comedic effect.

The reflexive attitude behind the exploration and performance of technique in *The Red Nose* was not limited to acting. As Chen Yong notes, in her director's treatment (*daoyan gousi* 導演構思) for the production:

This play requires the combined use of multimedial artistic elements, bringing together singing, dance, acrobatics, instrumental rhythms, monologues, all of these performing arts in front of one hearth. At the same time, it requires stage lighting, sets, makeup, costumes, props, sound effects, etc., each link, to make full use of their unique artistic capacities. The high level of technicality and attraction will become one of the most important characteristics of this performance.

這個戲裏要求多媒介藝術因素的綜合運用，集歌唱，舞蹈，雜耍，樂器演奏，獨角戲，表演藝術於一爐，同時要求舞台燈光，佈景，化妝造型，服裝，道具，音響效果等各個環節充分發揮各自獨特的藝術功能，高度的技巧性和趣味性將成為演出的重要特色之一。⁵⁶

Chen thus makes it quite clear that she sees the categories of stage technologies and acting technique as equally important and interrelated. In fact, she even went so far as to remark that: “One should not think that they simply accompany the actors – lighting, [sound] effects, and music are all creators of art. In this play, lighting, [sound] effects and music are all actors, must all perform.”⁵⁷ In *The Red Nose*, this was most obviously achieved by placing functional lighting units around the playing space, which lighting designer Guo Rongchen 郭榮忱 called “mobile

⁵⁵ This episode is absent both from the version of *The Red Nose* published in mainland China in 1982 and from versions published in Taiwan. Yao Yiwei, “Hong bizi,” in *Yao Yiwei xiju liuzhong*, 328–332.

⁵⁶ Chen Yong, “Daoyan gousi,” 28.

⁵⁷ “不要以為只是單純地配合演員表演，燈光，效果，音樂都應該是藝術創造者之一。在這齣戲裏，燈光，效果，音樂都是表演者，都要演戲。” Chen Yong, “Daoyan tanhua lu,” 37.

lights” (*liudong deng* 流動燈). Their purpose was to stand in defiance of illusionistic stage conventions and draw audience attention the fact that they were watching a play. Indeed, throughout his design, Guo worked to draw attention *to* the lighting in the hopes that: “The audience will at one moment watch the play, at another moment watch the lighting perform, and this will produce an estrangement effect.”⁵⁸ As described in the introduction to this chapter, Chen Yong and her design team also made the decision to dispense with the main curtain and allow the audience to observe and interact with stagehands as they moved props, set pieces, and lighting equipment.⁵⁹

From essays written by the director and designers, it is clear that the technical treatment of the show was inspired by the work of Bertolt Brecht. They repeatedly make reference to Brechtian estrangement effect (translated as *jianli xiaoguo* 間離效果), emphasize the anti-illusionistic elements of the production design, and discuss the use of heightened theatricality as a means of eliciting more critical responses among the audience. Their use of uncovered lighting equipment seems particularly reminiscent of the staging instructions that Brecht gives for his epic theater, and his exhortation that showing the lighting apparatus, perhaps more than any other technical element, was central to countering the realist theater’s concealment of its illusion-

⁵⁸ “觀眾一會兒看戲，一會兒看燈光表演，也就產生間離效果。” Guo Rongchen 郭榮忱, “Dengguang sheji de yixie shexiang 燈光設計的一些設想,” in *Hong bizi de wutai yishu* 《〈紅鼻子〉的舞台藝術》, ed. Lin Kehuan 林克欢 (Beijing: Zhongguo xiju chubanshe, 1984), 255–58.

⁵⁹ Some of the design concepts may have been influenced by descriptions of British, American, European, and Japanese theater space and set design theory and practice that were circulating on the pages of theater periodicals in the late 1970s and early 1980s. Several prominent theater artists took trips abroad and published reports, and delegations of foreign directors, actors, and designers also toured China. Most famously, Arthur Miller would direct *Death of a Salesman* at BPAT in 1983. Articles in this vein are too numerous to list in full here; see for example: Sun Haoran 孫浩然, “Yingguo huaju yanchu de guoqu yu xianzai 英國話劇演出的過去與現在,” *Renmin xiju* 《人民戲劇》 8 (1980): 44–47; Ying Ruocheng 英若城, “Xifang huaju biaoyan de xin faxian 西方話劇表演的新發現,” *Renmin xiju* 《人民戲劇》 11 (1980): 45–48; Xue Dianjie 薛殿傑, “Meiguo wutai meishu jianwen--fang Mei suibi erze 美國舞台美術見聞——訪美隨筆二則,” *Waiguo xiju* 《外國戲劇》 1 (1982): 123–29.

producing mechanisms.⁶⁰ Chen Yong had already co-directed the 1979 production of *The Life of Galileo* with Huang Zuolin and the China Youth Arts Theater, and would continue to experiment with Brechtian texts and techniques throughout her career.⁶¹

These direct engagements with Brecht speak to the popularity and influence of his theories of epic theater and the estrangement effect in 1980s China.⁶² Brecht had, in fact, been first introduced in China by Huang Zuolin decades earlier, with a production of *Mother Courage and Her Children* in 1958 and lectures for STA in 1962, in which he labeling Brechtian theater as one of three great theater systems (*xiju tixi* 戲劇體系), along with Stanislavsky and Mei Lanfang.⁶³ Restrictions on performance during the Cultural Revolution prevented any further explorations, and it was not until the production of *The Life of Galileo* critical responses, and widespread publication of articles on Brecht in the late 1970s that interest in his drama revived. Huang Zuolin, still an important figure in the theater world, continued to promote Brecht's work and a number of prominent theater artists began to reference epic theater and the estrangement

⁶⁰ Brecht makes reference to lighting throughout his essays on the epic theater, but most explicitly discusses this technique in a section on "Making Visible the Sources of Light" included in the notes to his "Short Description of a New Technique of Acting which Produces an Alienation Effect." Bertold Brecht, "Short Description of a New Technique of Acting Which Produces an Alienation Effect," in *Brecht on Theater: The Development of an Aesthetic*, ed. and trans. John Willet (London: Methuen, 1964), 141.

⁶¹ Chen Yong later directed both *The Caucasian Chalk Circle* and *Three Penny Opera*, and published articles on Chinese interpretations of Brechtian theory in both Chinese and English. See for example Chen Yong, "Brecht and the Current Transformation of the Theatre in China," *The Brecht Yearbook* 14 (1989): 47; *Wode yishu wutai*.

⁶² There is a large body of work on Brecht's influence in China in both Chinese- and English-language scholarship. An international conference on the topic of "Brecht and East Asian Theatre" was held as early as March 1981 and featured a number of presentations on Brecht and China. The proceedings of that conference have been published as Antony Tatlow, Tak-Wai Wong, and Hong Kong International Brecht Seminar, *Brecht and East Asian Theatre: The Proceedings of a Conference on Brecht in East Asian Theatre* (Hong Kong: Hong Kong University Press, 1982), http://nrs.harvard.edu/urn-3:hul.ebookbatch.PMUSE_batch:muse9789882200449. In English, see also: William Sun, "Mei Lanfang, Stanislavsky and Brecht on China's Stage and Their Aesthetic Significance"; Adrian Hsia, "The 'Brechtian' Drama of Sha Yexin," *Comparative Literature Studies* 30, no. 4 (1993): 405; Thomas Y. T. Luk, "From Brecht, Artaud, and the Absurd to Sha Yexin and Gao Xingjian: Two Cases of *Rapport de Fait*," *Comparative Literature Studies* 48, no. 1 (2011): 64–81, doi:10.5325/complitstudies.48.1.0064.

⁶³ The terminology of the "three great theater systems" came into parlance in the 1980s, but the concept was established in Huang's earlier work. A book on Brecht by Bian Zhilin 卞之琳 was also published that same year.

effect in relation to their creative work. As Xiaomei Chen has argued, Chinese theater artists “discovered that Brecht’s belief in the possibility of effecting social change through epic theater matched almost perfectly the way, in the Maoist realist tradition, that audiences were encouraged to ponder the historical process objectively through dramatic representations of the ‘typical’ and the ‘progressive.’”⁶⁴ However, Chen and others have also pointed out that Chinese appropriations of Brecht were often partial or remolded key concepts to better accord with local culture and ideological atmosphere.⁶⁵ In both formal borrowing and more theoretical discussions of the aesthetic goals of individual performances, Brechtian and anti-Brechtian impulses are often found side-by-side.

The same is no less true for Chen Yong and the design team for *The Red Nose*. To begin, Yao Yiwei’s script may not have been a work of Ibsenian realism, but neither was it written in the style of the epic theater. While the several diversions into the subjective, dream worlds of its characters and metatheatrical scenes certainly call attention to the theatricality of the play, they do not do so in a way that necessarily cultivates a distanced and critical response. When the actors playing the variety show troupe characters break into song and dance, for example, they are giving a performance for the other characters and do so well within the world of the play. Therefore, even if the actors address the audience directly at this moment, they are in effect incorporating the real audience into an “audience” that already exists onstage. In other words, direct address becomes an action of incorporation, rather than distancing. Furthermore, the designers did not take the principles of epic theater stage design to their extreme; there was no

⁶⁴ Xiaomei Chen, “A Stage in Search of a Tradition: The Dynamics of Form and Content in Post-Maoist Theatre,” *Asian Theatre Journal* 18, no. 2 (2001): 210. Reprinted in Chen, *Acting the Right Part*, 291–330.

⁶⁵ Chen discusses this phenomenon in relation to Gao Xingjian, in particular. Xiaomei Chen, “A ‘Wildman’ Between Two Cultures: Some Paradigmatic Remarks on ‘Influence Studies,’” *Comparative Literature Studies* 29, no. 4 (1992): 406.

use of projected titles, and despite Guo Rongchen's commitment to the concept of mobile lighting units, he did not go so far as to flood the stage with glaring white light. Instead, the full capacities of the sets, lights, and sound were deployed to communicate the physical and emotional atmosphere of the play to its audience.

Something of this underlying ambivalence toward a fully Brechtian staging is revealed in the same essays that otherwise describe elements of the design in very Brechtian terms. For example, Guo Rongchen remarks that:

When the audience sees the backstage operations that can't be seen on the illusionistic stage, on the one hand, we achieve non-illusionistic theatrical effects, and on the other hand, we also make the audience feel more intimate and enrich their artistic appreciation, taste, and knowledge.

觀眾看到了在幻覺主義的舞台上所不能看到的幕後操作，一方面達到了非幻覺主義的戲劇效果，一方面又使觀眾感到親切，豐富了他們的藝術欣賞趣味和知識。⁶⁶

Brechtian estrangement is thus balanced with the kind of familiarization that comes from understanding the technical inner workings of the theater—a goal reflected also in their desire, discussed above, for the audience members to ask stagehands questions as they set the stage before the performance. In this latter aspiration, this production of *The Red Nose* perhaps picks up the mantle of left-wing theater artists from the 1930s (discussed in Chapter 1) who, not entirely unlike Brecht, sought to simultaneously create political responses to their performances and also to educate audiences as to how modern theater technology worked. Furthermore, similar to the display of the labor of stagehands in *Roar, China!*, the 1982 production of *The Red Nose* also highlighted both the performance of stage technologies and the performance of stage technicians. After all, these lighting units, set pieces, and props did not perform magically on their own, but in the hands of human agents. Chen Yong and her designers thereby take the

⁶⁶ Guo Rongchen, "Dengguang sheji de yixie shexiang," 255.

technical challenges of staging *The Red Nose* and transform them into a humanizing performance of staging technology.

Chen Yong's directing theory aligns the technical challenges of acting and staging, and in this production, she and her creative team treated each with equal care. Both elements of the production were a success; well-known scenic designer and fellow member of the China Youth Arts Theater, Cai Tiliang 蔡體良, published an article in *Guangming ribao* 《光明日報》 (Guangming Daily) focused entirely on the production's innovative scenography. In another article, written for the journal *People's Theater*, Fu Chenglan 傅成藍 begins with the comment:

Anyone who has seen the performance of *The Red Nose* by the China Youth Arts Theater definitely won't forget that band of itinerant performers. They hide their sorrows behind masks, strike cymbals and bang on drums, sing and dance, turn cartwheels, make human pyramids, balance plates on their heads, turn magic tricks, and drive away the interminable silence of life with their laughter and cheerful voices. In that moment, you will be captivated by their free and easy spirit: could they be *huaju* actors? Perhaps they've been borrowed from an acrobatics troupe.

看過中國青年藝術劇院演出的《紅鼻子》的人，一定不會忘記戲中那個跑江湖的雜耍班子。他們把苦惱掩藏在面具後面，敲鑼打鼓，唱歌跳舞，耍流星，疊羅漢，頂盤子，變魔術，用歡聲笑語驅走了生活中無盡的死氣。此時此刻，你一定被他們那種輕鬆，自如的神態迷惑住了：他們是話劇演員嗎？也許是從雜技團借來的吧。⁶⁷

Later recalling the performance, Chen Yong would likewise remember with pride that many audience members, like Fu Chenglan, were fooled into believing that the performers were professional dancers and musicians, not *huaju* actors.⁶⁸ What the production of *The Red Nose* achieved, therefore, was a coeval display of both acting technique and performance technology that called attention as much to process as to product.

⁶⁷ Fu Chenglan 傅成藍, "Huaju tuanli de zaji yanyuan 話劇團裡的'雜技演員,'" *Renmin xiju* 《人民戲劇》 4 (1982): 20.

⁶⁸ Chen Yong, *Wode yishu wutai*, 341.

Staging Process in Little Theater

A notable event in its own right, the production of *The Red Nose* in 1982 is further significant because it inaugurates in 1980s *huaju* a trend of the play serving as a vehicle for showcasing acting technique and creative process. The importance of physicality to the little theater experiments that flourished in the mid-1980s has been widely acknowledged, both by theater artists themselves and by scholarship. For instance, in his seminal text on avant-garde theater in China, theater historian Chen Jide 陳吉德 notes the importance of form (*xingshi yanchu* 形式演出) and physical gesture (*xingti dongzuo* 形體動作) to avant-garde theatrical performance, especially in the work of director Mou Sen 牟森 (b. 1963).⁶⁹ Likewise, Xiaomei Chen has examined a group of experimental plays from the early post-Mao period on the basis of their recognition for innovations in dramatic form and performance technique, although her argument focuses on the inseparability of both from their historical and political contexts, and Izabella Łabędzka has discussed the staging of acting technique as metatheater in the work of Gao Xingjian.⁷⁰ In the following, I will return to some of the same pieces discussed by Chen and Łabędzka, but I will argue for the importance of considering their performances *of* technique in relation to the broader concerns that I have outlined above.

⁶⁹ Other characteristics that Chen attributes to “avant-garde theater” (*xianfeng* 先鋒戲劇) include emphasis of suppositionality (*jiadingxing* 假定性), actor-audience interaction, and theatricality (*juchangxing* 劇場性). Chen Jide, *Zhongguo dangdai xianfeng xiju*, 71–78; Ferrari, *Pop Goes the Avant-Garde*, 7–19.

⁷⁰ One might argue that Chen uses “formalistic features” as a straw man for her discussion of the relationship between form and content in *Chezhan* 《車站》 (Bus Stop, 1983), *WM* (1985), *Wuwai you reliu* 《屋外有熱流》 (Hot Currents outside the House, 1980), Wei Minglun’s *Pan Jinlian* 《潘金蓮》 (1986), *Zhongguo meng* 《中國夢》 (China Dream, 1986) and others. While the formal innovations of these plays, both in text and onstage, certainly generated widespread discussions and contentious debates in the mid-1980s, many of these were just as concerned with content as with form. (For example, debates over the figure of the “Silent Man” in *Bus Stop*). Chen, “A Stage in Search of a Tradition,” 220–221.

Two of the most iconic little theater pieces of the 1980s in this regard were *Gua zai qiangshang de Lao B* 《掛在牆上的老 B》 (Old B Hanging on the Wall) and *Zhongguo meng* 《中國夢》 (China Dream), both written by William Huizhu Sun (Sun Huizhu 孫惠柱).⁷¹ The title of the former uses an idiom similar to “hanging up one’s hat” to make explicit reference to the predicament of many actors during the Cultural Revolution, when they were forced to cease performing and “hang up” their costumes.⁷² Often referred to as a metatheatrical piece, *Old B* opens with a “rehearsal” for an experimental performance and an interruption by an actor called “Old B,” who demands an audition. In what follows, Old B reads a number of scenes, toggling between different characters, as well as in-and-out of flashbacks. As Sun himself and Faye Chunfang Fei describe it,

The play’s multilayeredness requires acting skills ranging from highly naturalistic to highly stylized. Its nonlinear story requires the actors to move swiftly in and out of different mental states and times and to convey all these changes in their bodies without the assistance of lighting, costumes, or scene changes, except for the occasional use of masks.⁷³

Even from this brief description, it can be seen that this production required precisely the kind of performer that I have termed the “multimedial actor” and which Chen Yong sought to create in her production of *The Red Nose*. It is perhaps unsurprising, therefore, that Chen Yong had a hand in bringing *Old B* to the stage and that directors Wang Xiaoying 王曉鷹 and Gong Xiaodong 宮曉

⁷¹ William Sun received his PhD from New York University in 1990. He remains a leading scholar and playwright, based at the Shanghai Theater Academy. For more detailed treatments of his work than I provide here, see for example: Chapter 3 in Conceison, *Significant Other*, 68–89; Emily Wilcox, “Meaning in Movement: Adaptation and the Xiqu Body in Intercultural Chinese Theatre,” *TDR: The Drama Review* 58, no. 1 [T221] (2014): 42–63, doi:10.1162/DRAM_a_00327.

⁷² William Huizhu Sun and Faye Chunfang Fei, “The Old B Hanging on the Wall in the Changing Chinese Theatre,” *TDR: The Drama Review* 30 (1986): 84.

⁷³ *Ibid.*, 87.

東 chose to adopt techniques from *Towards a Poor Theatre* in rehearsal and performance.⁷⁴ The play premiered on November 16, 1984 in Beijing, and on to tour to several major cities, where they performed primarily in university auditoriums, dining halls and gymnasiums.

William Sun's second play, *China Dream*, moved away from metatheater, but continued in the vein of foregrounding acting technique. Inspired by their first year abroad, he and Faye Chunfang Fei composed an episodic piece that narrates the intercultural love story of John, a lawyer-turned-PhD student (in Chinese philosophy), and Mingming, a Chinese actress who has recently immigrated to the United States.⁷⁵ As Sun and Fei have noted, part of their motivation for writing the piece was a desire to combine the "fluidity of Chinese sung drama" with the episodic, presentational style popular in experimental Western theater at the time.⁷⁶ In her appraisal of the piece, Xiaomei Chen writes:

The play in fact is a showcase for acting techniques from traditional opera and modern drama, as well as from the song-dance drama (*gewuju*). By using one actor to play six different roles—American lover and Chinese lover, restaurant chef, waiter, journalist, Mingming's grandfather—the play achieves an unusual degree of theatrical fluidity and continuity that contributes to the imaginative flow.⁷⁷

The play's Chinese premiere in Shanghai in 1987 served, furthermore, a vehicle for director Huang Zuolin's concept of "impressionistic" or "ideographic" (*xieyi* 寫意) aesthetics, which like the script fuses modern Western and *xiqu* techniques. The production also used a bare stage

⁷⁴ Ibid., 89–90. In their article on *Old B*, Sun and Faye Chunfang Fei detail how Chen Yong helped rush the play to production and circumvent the usual censorship process. As newly appointed vice president of the China Youth Arts Theater, Chen was able to get rehearsals started before the production had been officially approved, and to convince a censoring committee to base approval on a run-thru of the show already in process.

⁷⁵ I watched a recording of the 2014 revival. For a discussion of the play and its intercultural themes, see Chapter 3 "Immigrant Interculturalism" in Conceison, *Significant Other*, 68–89.

⁷⁶ Willam Huizhu Sun and Faye Chunfang Fei, "China Dream: A Theatrical Dialogue between East and West," in *Intercultural Performance Reader*, ed. Patrice Pavis (New York: Routledge, 1996), 190–91.

⁷⁷ Chen, *Acting the Right Part*, 307.

design in order to further highlight the actors' abilities to bring the dramatic world to life with only simple props and gestures.

Any number of the many pieces from this period that, like *China Dream*, experimented with integrating techniques from *xiqu* with *huaju* or with use of a minimalist staging might offer further grounds for exploring the staging of technique and process. However, perhaps the most sophisticated example of this trend can be found in the work of Gao Xingjian, and in particular, in his piece *Bi'an* 《彼岸》 (The Other Shore, 1986).⁷⁸ *The Other Shore* is comprised of loosely connected episodes in which actors perform the process of entering into theatrical roles, rehearsing generalizable scenarios, and returning to their non-performing selves. In one scene, for example, a Woman teaches a Crowd to speak, only to have them violently turn on her; in another a Man is swindled in a game of cards. Acknowledging how abstract, even impenetrable the piece may seem to readers (or rather, potential performers), Gao Xingjian includes several suggestions for production with his script. The first of these reads:

The so-called 'spoken drama' (*huaju*) tends to emphasize and highlight the art of language; in order to free drama from its constraints and to revive drama in all its functions as a performing art, we have to provide training for a new breed of modern actors. As with the actors in traditional operas, these new actors must be versatile, and their skills should include singing, the martial arts, stylized movements, and delivering dialogues. They should also be able to perform Shakespeare, Ibsen, Chekov, Aristophanes, Racine, Lao She, Cao Yu, Guo Moruo, Goethe, Brecht, Pirandello, Beckett, and even mimes and musicals. The present play is written with the intention of providing an all-around training for the actors.⁷⁹

⁷⁸ Here, I am much indebted to the work of Izabella Łabędzka. She has argued that a number of Gao Xingjian's plays from the 1980s are metatheatrical performances of his theories about acting and theatricality, and her chapter on the topic gives an excellent analysis of Gao's use of metatheater, metadrama, and acting theory, with reference to relevant Western theorists and parallel experiments in other Chinese works from the 1980s. See Chapter 2 "The Actor in the Space of Illusion and Anti-Illusion" in Łabędzka, *Gao Xingjian's Idea of Theatre*, 31–92.

⁷⁹ Gao Xingjian, "Some Suggestions on Producing The Other Shore," in *The Other Shore: Plays*, ed. and trans. Gilbert C.F. Fong (Hong Kong: Chinese University of Hong Kong, 1999), 42.

In these notes, Gao also makes direct reference to Grotowski, comparing the work of *The Other Shore* to the training methods associated with the poor theater, such as the concept of performance as a process of self-discovery and a form of sacrifice.⁸⁰ Additionally, similar to the discussions of actor training in *Theater Arts*, Gao also draws a distinction between his the work of the *huaju* actor and performers in other forms, writing: "...the performance must be fresh, regenerating, and improvisational, which is essentially different from gymnastic or musical performances."⁸¹

We might also draw a parallel between the clown character of "Red Nose" from Yao Yiwei's play and the many clownish characters that populate Gao Xingjian's theatrical worlds. In *The Other Shore*, for instance, one of the vignettes features a Plaster Seller, a comedic mountebank peddling a spurious cure-all. Sy Ren Quah, one of the leading scholars on Gao Xingjian, has argued for the importance of the carnivalesque to Gao Xingjian's work. Likening Gao's repeated use of the clown and the charlatan to both Bakhtin's famous discussion of the carnival and to the *chou* 丑 role-type in Chinese *xiqu*, Quah argues that:

Whereas Bakhtinian carnival laughter is an effect that literary works produce, for Gao, carnivalesqueness is a technique to create an extended theatrical experience. When he creates a carnival mood and uses clown characters in his theater, Gao does not conceal the fact that within a common sphere, the theatrical space, reality and laughter coexist. It is exactly the juxtaposition of the real and the unreal that provides a different approach to reception and interpretation.⁸²

⁸⁰ Ibid., 43. There is some question as to when Gao first encountered Grotowski. Izabella Łabędzka correctly notes that Gao had the opportunity to read Grotowski before the full translation of *Towards a Poor Theater* came out in 1984, as evidenced by the two essays mentioning Grotowski dated September and December 1982, respectively, and later published in *Suibi* 《隨筆》. She cites as these sources the two articles published in the fourth issue of *Theater Arts* that came out in 1982. However, at the time, *Theater Arts* was a quarterly publication. This means that the essays on Grotowski would probably not have come out before September 1982. Therefore, Gao must have had access to advance copies of these two essays, or perhaps read the earlier essays published in *Foreign Drama* in 1980 and early 1982. (Łabędzka does not include the latter essays in her notes or discussion.) See Łabędzka, *Gao Xingjian's Idea of Theatre*, 44-45.

⁸¹ Gao, "Some Suggestions on Producing *The Other Shore*," 44.

⁸² Quah, *Gao Xingjian and Transcultural Chinese Theater*, 120.

Quah goes on to correctly point out that the *chou* role-type in *xiqu* has the most flexibility of any role type, and must be able to perform the other role-types, to improvise, and to perform acrobatic tricks.⁸³ In short, he must be an exceptionally versatile and virtuosic performer; in fact, the clown/*chou* may be the closest possible embodiment of what Gao refers to as the “total actor” (*quanneng de yanyuan* 全能的演員).⁸⁴

In her recent monograph on Gao Xingjian, Izabella Łabędzka makes a similar interpretive move to Sy Ren Quan when she associates the mastery of acting technique with revealing the boundary between the real and the unreal in Gao’s work. She writes of Gao’s concept of the theater:

The theatre which considers acting technique to be the most important, gives considerable prominence to persons who are perfect masters of the technique—that is, to actors. The actor in such a theatre is the main force displaying the artificiality of things which the audience witnesses and in which it participates.”⁸⁵

Both Quan and Łabędzka offer insightful analyses that compliment one another, but their shared focus on the “juxtaposition of the real and the unreal” also draws attention to one of the few problems with the many excellent studies that have been done on Gao Xingjian and, indeed, theater and performance from this period more generally. That is to say, scholarship tends to focus on the pervasive crisis of representation that artists, writers, and intellectuals faced in mainland China in the 1980s. As Quah describes it in his background introduction:

⁸³ Ibid., 121. For a detailed study of the *chou* role, see Ashley Thorpe, *The Role of the Chou (“clown”) in Traditional Chinese Drama: Comedy, Criticism, and Cosmology on the Chinese Stage* (Lewiston: Edwin Mellen Press, 2007).

⁸⁴ Quah discusses the “total actor” but not in relation to the clown. In his own writing, Gao Xingjian has said that the concept of the total actor is rooted in the basic principles of *xiqu* acting. Quah, *Gao Xingjian and Transcultural Chinese Theater*, 96–104; Gao Xingjian 高行健, “Jinghua yetan 京華夜談,” in *Dui yizhong xiandai xiju de zhuiqiu* 《對一種現代戲劇的追求》 (Beijing: Zhongguo xiju chubanshe, 1988), 215.

⁸⁵ Łabędzka, *Gao Xingjian’s Idea of Theatre*, 82.

In the field of drama, the challenge to Stanislavskian representation continued to be an important part of dramatists' endeavors. On the one hand, exploration into new areas, especially modernism and humanism, forced realism to face 'a self-subverting crisis' (Chen Xiaoming 1996:160) and intensified the reexamination of realist representational modes. On the other hand, the establishment of a new aesthetic suggested different ways of representing reality and thus provided alternative perspectives on how reality could be perceived."⁸⁶

Or, as Łabędzka frames it: "The extraordinary abundance of metatheatrical strategies in Chinese theatre of the 1980s and 1990s can be interpreted as a reaction of the many years' domination of socialist realism poetics with its shallow and flat image of man and the world, and also as an expression of the need for a deeper aesthetic reflection and consideration of the special character of the theatrical language."⁸⁷ However, the consistent attention to actor training and technique, onstage and off, discussed in this chapter suggest that alongside this crisis of representation ran a parallel crisis of embodiment. Like the crisis of representation, it can be seen as both a legacy of the Cultural Revolution and a product of the rapid modernizations of the 1980s.⁸⁸ The theater that formed the direct antecedent to the theater of the 1980s was not *huaju*, and it was not realist drama. It was the revolutionary *yangbanxi*, in which the utopian representations onstage were more truly illusions (*huanjue* 幻覺) than any "illusionistic" stage scenery and of which the most illusory element was that of the technically perfect performer.

If we reframe our analysis of Gao Xingjian with this crisis of embodiment, we may find our attention drawn to his more explicit discussions of the *xiqu* actor as the model for his ideal actor. Gilbert Fong, for example, notes a particular reference to the concept of "striking a pose"

⁸⁶ Quah, *Gao Xingjian and Transcultural Chinese Theater*, 55.

⁸⁷ Łabędzka, *Gao Xingjian's Idea of Theatre*, 83.

⁸⁸ A recent article by theater scholar Glenn Odom calls attention to the lack of scholarship placing Gao Xingjian in the context of socialist literary and aesthetic practices. Odom's article does bring up the *yangbanxi*, but focuses on their representation of character. Glenn Odom, "Socialist Realism and New Subjectivities: Modern Acting in Gao Xingjian's Cold Theatre," *Asian Theatre Journal* 31, no. 1 (2014): 153–78.

(*liangxiang* 亮相) in Gao Xingjian's discussion of his theory of the tripartition of acting. In brief, Gao understands the traditional *xiqu* actor to enter a state of neutrality before taking the stage, and to therefore always simultaneously possess three identities: the self, the neutral actor, and the character.⁸⁹ Paraphrasing Gao's description of the *liangxiang*, Fong writes:

At the time of *liangxiang*, the actor freezes his movement for a few seconds to mark his entrance of the completion of a display of martial arts, dance sequence, etc. thus making himself 'appear' before his audience, who applaud and voice their approval. The performance is briefly suspended, as the actor neutralizes his acting capacity and calls attention to the exhibition of his art."⁹⁰

In other words, the neutrality of the "neutral actor" can be seen and felt onstage in the emptiness of the moment of *liangxiang*.

The way in which Gao describes the *liangxiang*, and indeed, the way that many theater artists of the 1980s envisioned *xiqu*, seems to imply a well-established, inviolable way of interpreting the *xiqu* convention. However, if we return to the *yangbanxi*, or at least to scholarship on the *yangbanxi*, we find a rather different description of the function of the *liangxiang*:

in traditional Chinese *jingju*, the poses or *liangxiang*, in which the actors periodically come to a momentary rest, are an essential part of the performance and a principal means by which the performance is made legible and enjoyable to the audience. These ritualized, frozen postures punctuate passages of movement, dialogue, or song and become semantic units in the narrative...they strive not for mimetic resemblance to real human behavior but rather for a codification of emotion that the audience can read through their familiarity with dramatic conventions. In the Cultural Revolution *yangbanxi*, these codes

⁸⁹ Gilbert C.F. Fong, "Introduction," in *The Other Shore: Plays by Gao Xingjian*, ed. and trans. Gilbert C.F. Fong (Hong Kong: Chinese University of Hong Kong, 1999), xx.

⁹⁰ Gao's original text reads: "就其表演的瞬間而言，戲曲演員的亮相最能說明問題。演員踩著鑼鼓點子已經上場，屏息注視台下，將目光朝觀眾一一看去，同觀眾即刻建立交流，此時此刻，他那目光既是角色，又是演員，還又是他自己。如果把這一心理過程放大加以描模的話，那就是說：諸位請看，今兒個我梅蘭芳（譬如說），再次扮演的，乃妙齡少女秋江也！那眼神已經掃過，台下隨即掌聲叫絕，演員扮演的角色便這樣立在舞台上了。也即，扮演者自我審視，以演員身分，扮演角色，通過和觀眾交流得以確認，便活在舞台上了，一個角色的創造便得以完。" Ibid.; Gao Xingjian 高行健, "Wode xiju he wode yaoshi 我的戲劇和我的鑰匙," in *Meiyou zhuyi 《沒有主義》* (Hong Kong: Cosmos Books, 2000), 238–239.

became standardized to the point of cliché, so that one could tell with a glance at the posture of a character, for example, whether he or she was a hero.”⁹¹

In the above, which is drawn from an article on the *yangbanxi* films, Jason McGrath provides a description of the *liangxiang* almost identical to that of Gao Xingjian, but interprets it quite differently. Where Gao’s *liangxiang* is suspended and neutral, McGrath’s is affectively encoded. McGrath goes on to draw on Haiping Yan’s discussion of theatricality in *xiqu*, quoting her claim that: “Chinese music-drama aims not only to pull audiences out of their regular state of mind but also move them to another sphere where surprises and wonders are registers of another kind of ‘truth,’ deeply mediated by or buried in what is real.”⁹² In the *yangbanxi*, McGrath argues, the mediated truth to which the *liangxiang* gesture points is nothing less than the Truth of Communism and its ideals. The *liangxiang* thereby became both a visual trope of revolutionary stage aesthetics and central to their ideological agenda.

In Gao Xingjian’s vision, however, the neutral *liangxiang* points not to the socialist utopian future, guaranteed by Communist teleology, but rather to the immediate past and what has just happened on stage: a display of martial arts or acrobatics. The actor’s pause calls attention to nothing but himself and his own virtuosity. Therefore, if McGrath is correct about the function of the *liangxiang* in the *yangbanxi*, then in a single gesture, Gao Xingjian effectively replaces the entire Chinese Communist ideological system with the multimedial acting body. In seizing upon the *liangxiang* as the paradigmatic example of performance technique, his acting theory not only reclaims one particular technique that had become a hallmark of the *yangbanxi*,

⁹¹ McGrath, “Cultural Revolution Model Opera Films,” 360.

⁹² Haiping Yan, “Theatricality in Classical Chinese Drama,” in *Theatricality*, ed. Tracy C. Davis and Thomas Postlewait (Cambridge, UK: Cambridge University Press, 2003), 369. Cited in McGrath, “Cultural Revolution Model Opera Films,” 369.

but also radically rewrites—and then restages, in his metatheatrical work—the revolutionary codes of performance.

Re-Production Manuals: A Page from the Cultural Revolution Playbook?

There is one final stage on which we find performances of technique and process playing out in the 1980s: the sketched outlines of playing space layouts included in printed volumes on production process. In 1984, two years after the production of *The Red Nose*, a volume entitled *Hongbizi de Wutai Yishu* 《紅鼻子的舞台藝術》 (The Stage Art of *The Red Nose*) was published by the Chinese Drama Press (Zhongguo xiju chubanshe 中國戲劇出版社). Between two nondescript covers, it contains a unique record of the 1982 production directed by Chen Yong. A director's treatment and notes from discussions with actors in rehearsal give a robust picture of Chen Yong's vision and how she put it into practice (and have informed much of the discussion in this chapter). Essays by cast members, from the star playing "Red Nose" down to one who, in a self-effacing title, makes reference to the fact that he only had two lines, offer unique and subjective reactions to rehearsals—especially the unorthodox training methods eagerly implemented by their director. Designers' notes and a few images flesh out the performance, while a full production script captures details of actors' movements and emendations to the original script.

The volume was, however, not as original as it seemed. Rather, it was part of a series of like texts focusing on the "Stage Art" of classic plays such as *Thunderstorm*, *Chaguan* 《茶館》 (Teahouse), *Luotuo Xiangzi* 《駱駝祥子》 (Camel Xiangzi), *Cai Wenji* 《蔡文姬》 (Cai Wenji),

Fengxue ye guiren 《風雪夜歸人》 (Return on a Snowy Night), and *Dragon Beard Ditch*.⁹³

When examined on its own, *The Stage Art of The Red Nose* seems a unique window into the theatrical past, but when examined together, these “Stage Art” volumes start to take on an uneasy resemblance to an earlier series of technical texts—the production manuals for the *yangbanxi*—and their illusion of theatrical reproducibility (discussed in the Interlude). Although absent the iconic red-and-gold covers of *yangbanxi* production manuals, detailed blocking diagrams included in the “Stage Arts” volumes are reminiscent of the choreography and movement notation in the *yangbanxi* ballet manuals. The *Thunderstorm* volume, for example, features 200 pages of notes from the production log (*changji* 場記), compiled by Liu Tao 劉濤.⁹⁴ Opening to any given page, one will find a few lines of dialogue on the left-hand leaf, and on the opposing page, a sketch of the stage with actors’ lines of movement indicated and stick figure drawings of important gestures. [Figure 29] Detailed notes accompanying the sketches record not only the correct timing of each movement, but also the motivations and feelings of the characters. Far beyond indicating the basic entrances, exits, and crosses, the published production log provides enough information for new actors to replicate the motions and emotions of their predecessors.

⁹³ Su Min 蘇民 et al., ed., *Leiyu de wutai yishu* 《〈雷雨〉的舞臺藝術》 (Shanghai: Shanghai wenyi chubanshe, 1982); Beijing renmin yishu juyuan Yishu yanjiu ziliao bianjizu 北京人民藝術劇院《藝術研究資料》編輯組, ed., *Chaguan de wutai yishu* 《〈茶館〉的舞臺藝術》 (Beijing: Zhongguo xiju chubanshe, 1980); Beijing renmin yishu juyuan yishu yanjiu ziliao bianjizu 北京人民藝術劇院《藝術研究資料》編輯組, ed., *Luotuo Xiangzi de wutai yishu* 《〈駱駝祥子〉的舞臺藝術》 (Beijing: Zhongguo xiju chubanshe, 1982); Beijing renmin yishu juyuan Yishu yanjiu ziliao bianjizu 北京人民藝術劇院《藝術研究資料》編輯組, *Cai Wenji de wutai yishu* 《〈蔡文姬〉的舞臺藝術》 (Shanghai: Shanghai wenyi chubanshe, 1981); Wang Zheng 王正 et al., ed., *Fengxue ye guiren de wutai yishu* 《〈風雪夜歸人〉的舞臺藝術》 (Beijing: Zhongguo xiju chubanshe, 1984); Beijing renmin yishu juyuan yishu yanjiu ziliao bianjizu 北京人民藝術劇院《藝術研究資料》編輯組, ed., *Longxugou de wutai yishu* 《〈龍鬚溝〉的舞臺藝術》 (Beijing: Zhongguo xiju chubanshe, 1987).

⁹⁴ At BPAT and other state-sponsored *huaju* theater troupes in China, it is common to employ a production assistant specifically to keep a detailed log of everything that transpires in rehearsal and to record the final blocking. The role is perhaps most similar to that of an assistant stage manager in professional theater in the United States, but the position is distinct from that of stage manager. Production logs are kept in the theater archives and referenced in preparation for revivals, but relatively few are published.

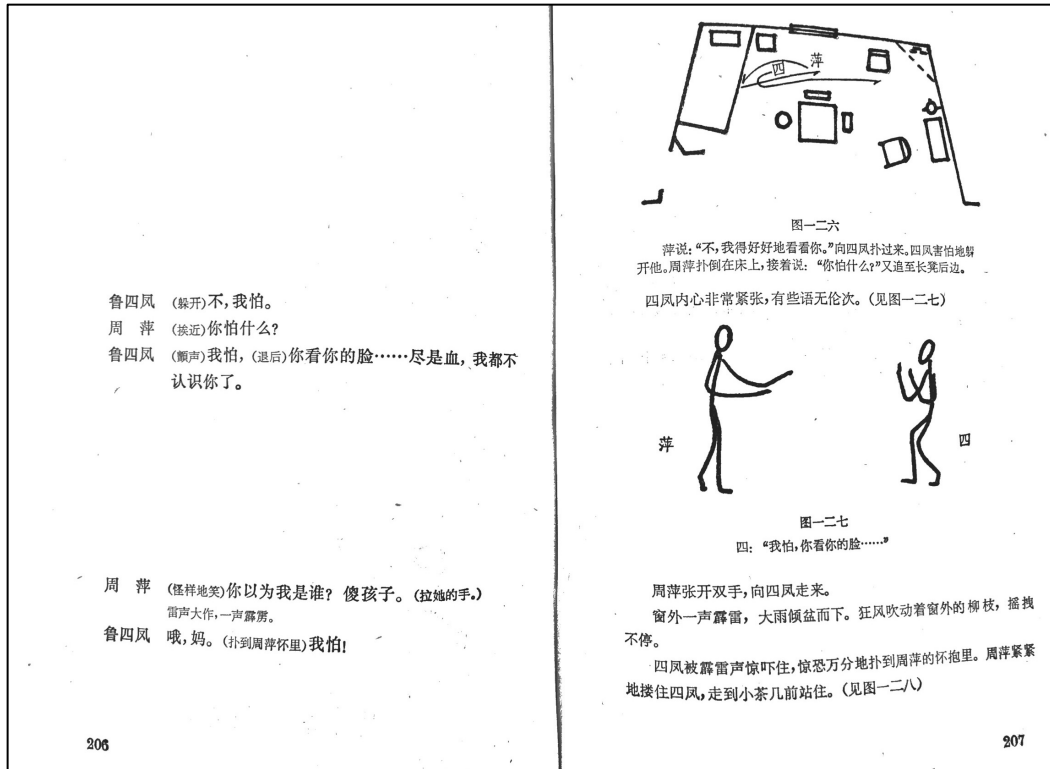

Figure 29 Blocking and stage directions for Act 3 in *Thunderstorm* (Source: *Leiyu de wutai yishu*, 1982)

In addition to this formal similarity, some of the “Stage Art” volumes explicitly presented themselves with the goal systematizing artistic production and as models for “socialist theater culture.” The preface for the *Thunderstorm* volume, written by prominent cultural official and theater theorist Zhao Xun 趙尋, states:

[we aim to] use Marxist concepts to deeply and actively, and not dogmatically, explicate the artistic characteristics of these repertory pieces and the creative experiences of their playwrights and artists, and to make them systematic, theoretical, and scientific. This is an important and urgent task of our work in theater theory, and it is fundamental to establishing our nation’s *huaju* art. Following the publication of *The Stage Art of Teahouse* and *The Stage Art of Cai Wenji*, BPAT has compiled *The Stage Art of Thunderstorm*. They are collecting the experiences of their best repertory pieces one by one, and this without a doubt does important work for the establishment of our country’s *huaju* artistry and a Chinese *huaju* system.

用馬克思主義觀點深刻地,生動地而不是教條主義地闡明這些保留劇目的藝術特色及其作家,藝術家的創作經驗,使之系統化,理論化,科學化,這是我們戲劇理論工作一項重要而緊迫的任務,是我國話劇藝術的基本建設。北京人藝繼《〈茶館〉的舞台藝術》和《〈蔡文姬〉的舞台藝術》出版之後,又編寫了《〈雷雨〉的舞台

藝術》，並將對其他優秀保留劇目的經驗一一加以整理，這對我國話劇舞台藝術的建設，對我國民族話劇藝術體系的建立，無疑是一件重要的工作。

... In addition, these few works occupy our stages, and the dramatic theory that comes out of practice experience will lead developments in the theater, as well as setting forth models for socialist theater culture.

此外，這些優秀的話劇佔領了舞台，這些從藝術實踐中產生的戲劇理論指導了戲劇的發展，也為社會主義的戲劇文化樹立了榜樣。⁹⁵

Most interesting here are the ideas that the publication of these “Stage Art” volumes is indicative of the quality and status of the works represented, and that a systematic theory of huaju might be developed to serve as a model. Zhao Xun attempts to distance himself from Cultural Revolution artistic theory and politics by decrying “dogmatism” and using the word *bangyang* 榜樣 for “model,” rather than the *yangban* (model) of the *yangbanxi* (model operas). Moreover, as a cultural bureaucrat and not one of the theater artists directly involved in the production of these theatrical works or volumes, his words should not necessarily be taken as expressing their intentions. Nonetheless, the entire enterprise of designating model works and disseminating materials that, hypothetically at least, enable their further re-production echoes uneasily the mechanisms by which politics coopted the performing arts during the Cultural Revolution.

To be sure, even the model “Stage Art” volumes distinguish themselves from the *yangbanxi* in key ways. First of all, these texts seem to target very different audiences than the *yangbanxi* performance manuals. On the one hand, actual audiences—fans of the actors, especially—might be interested in access to the hidden details of backstage life. At the same time, the goals outlined in Zhao Xun’s preface to the *Thunderstorm* volume seem to speak to professional huaju troupes, not aspiring amateur *xiqu* singers or ballet dancers. Furthermore,

⁹⁵ Zhao Xun 趙尋, “Xu 序 (Preface),” in *Leiyu de wutai yishu* 《〈雷雨〉的舞台藝術》, ed. Su Min 蘇民 et al. (Shanghai: Shanghai wenyi chubanshe, 1982), 5–6.

while there may be similarities in the endless pages of blocking diagrams and notes, the texts from the 1980s spare their reader meticulous set and prop blueprints, lighting plots, and cue sheets. As in *The Stage Art of The Red Nose*, scenographic details details are still provided, but they come in the form of a few select production photographs, sketches, and essays by set, lighting, costume, and makeup designers. These join director's notes and essays by individual actors on characterization and the rehearsal process. Each essay is attributed and allows its author to claim his or her subjective experience of the production, as well as to stake a claim for individual artistic genius. Together, they offer the reader multiple perspectives on the creative process and emphasize, rather than elide, the energy and long hours of labor that all members of the production team devoted to its realization. As a publication announcement for the "Stage Art" volume for Lao She's *Teahouse*, another of the BPAT classics, frames the work of the volume in precisely these terms:

But *how* does such a treasure of huaju history shine forth its brilliance? How do the directors, actors, and stage art workers put forth such pride-worthy labors? This volume on *The Stage Art of Teahouse* gives us a concrete and vivid introduction.

話劇史上的這一瑰寶是如何放射出耀人的光彩，北京人藝的導演，演員，舞台美術工作者們又付出了哪些值得驕傲的勞動呢？《〈茶館〉的舞台藝術》一書為我們做了具體而生動的介紹。⁹⁶

Whereas the *yangbanxi* production manuals erased traces of individual artistic labor in favor of highlighting the collective, these "Stage Art" volumes call attention to the performing arts both as labor (*laodong* 勞動) and as composites of many different contributors. Rather than emphasizing a codified and reproducible product, they applaud the nuances of a variegated artistic process.

⁹⁶ Huang Zaimin 黃在敏, "Yifen baogui de yishu cailiao--jieshao *Chaguan de wutai yishu* 一份寶貴的藝術財富——介紹《〈茶館〉的舞台藝術》一書," in *Zhongguo xiju nianjian 1981* 《中國戲劇年鑑 1981》(Beijing: Zhongguo xiju chubanshe, 1981), 240.

Nonetheless, for the majority of these “Stage Art” volumes, publication was tied to a particular revival performance staged by the Beijing People’s Art Theater. In the years following the Cultural Revolution, it became common practice for theater companies to restage plays from their pre-Cultural Revolution repertoire. For the 1979 theater season, BPAT produced two new plays and a revival of Cao Yu’s *Thunderstorm*, which the company had first performed in June 1954. Reviving repertory works (*baoliu jumu* 保留劇目) was not without precedent, nor was it significant in and of itself.⁹⁷ While BPAT prided itself on premiering new work by the best playwrights in the country, it also had been conceived as a repertory company and, before the Cultural Revolution, was already working to establish a billet of modern classics. Cao Yu’s famous trilogy of *Thunderstorm*, *Sunrise*, and *Beijing ren* 《北京人》 (Peking Man) had all been written and premiered in the 1930s-1940s, and when BPAT took them up in 1950s they were already well known.⁹⁸

Surprisingly, when BPAT re-staged *Thunderstorm* in 1979 nearly all of the original company reprised their roles. Xia Chun 夏淳 directed, with a design team of Chen Yongxiang 陳永祥, Song Yin 宋垠 and Guan Zaisheng 關哉生, and the characters of Sifeng, Zhou Ping, Zhou

⁹⁷ The first show to be explicitly marked as a revival (*chongpai* 重排 or *fupai* 復排) on the BPAT website is the 1963 production of Tian Han’s *Guan Hanqing*, which had premiered only a few years earlier in 1958 (as discussed in Chapter 2). In this case, there was significant turnover in the actors and creative team involved with the production. The director, Jiao Juyin 焦菊蔭, remained the same, but his original co-director Ouyang Shanzun 歐陽山尊 was not involved and, according to the director’s and designers’ notes held in BPAT archives, several major changes were made to the director and design of the revival. “Guan Hanqing Yanchu Ben 《關漢卿演出本》 (Guan Hanqing Production Script),” 1963, Beijing renmin yishu juyuan bowuguan 北京人民藝術劇院博物館; “Guan Hanqing daoyan, sheji tan wutai meishu 《關漢卿》導演，設計談舞臺美術,” 1963 (BPAT Theater Museum Archive).

⁹⁸ The trilogy originally included *Yuanye* 《原野》 (The Wilderness, 1937), but the play’s Expressionist style and dark portrayal of the human psyche conflicted with the socialist realist style espoused by BPAT in the 1950s. *Wilderness* was replaced by *Peking Man* in the BPAT repertoire until Li Liuyi 李六乙 directed a black box production for the BPAT Experimental Theater in August 2000.



Figures 30-33 BPAT *Thunderstorm* productions: 1954 (top left) 1979 (top right), 1989 (bottom left), 1997 (bottom right). (Source: Beijing renmin yishu juyuan website, www.bjry.com)

Puyuan, Lu Shiping, and Lu Dahai all played by the same actors as in 1954.⁹⁹ And while consistency of cast and creative team does not necessarily imply a mechanical copy of an earlier production, if we look to production photographs, we can see remarkable similarities in the scenic design between 1954 and 1979. [Figures 30-33] *Thunderstorm* features two main settings: Acts 1, 2, and 4 take place in the lavishly appointed living room of the wealthy Zhou family, and Act 3 takes place in the bare-bones home of their servants, the Lu family. As can be see from

⁹⁹ This evidence is drawn from cast lists on the BPAT website, www.bjry.com, which list two or three actors for some parts (suggesting understudies). Similarly, the volume *Leiyu de wutai yishu* 《〈茶館〉的舞台藝術》 (Stage Art of *Thunderstorm*) includes photographs of several different actors for each character; some of these could come from the 1959 revival, which is discussed in secondary scholarship but not listed on the BPAT website as one of their main productions.

Figure 30, the Zhou family living room in 1954 featured plush, fabric-covered sofas, ornately carved tables and stools, a gilt tabletop pendulum clock, and wall decorations like an oil painting, landscape scroll, calligraphy, and a painted fan. decorating the living room, scenic designer Chen Yongxiang carefully considered the admixture of styles that would result from a Western-educated young man combining treasures acquired in Europe with possessions inherited from his family.¹⁰⁰ Each set prop is therefore quite distinctive—so distinctive, in fact, that it is impossible not to recognize the pieces of furniture and art when they reappear, in nearly the same positions, in photographs from future productions.

For the 1979 revival, director Xia Chun has commented on the changes in characterization that he made from the 1954 production of *Thunderstorm*, which suggests that the performances, at least, were not as repetitious as the scenery.¹⁰¹ However, *after* the 1979 revival, BPAT would continue to perform *Thunderstorm* and other classics in repertoire at least once a decade. Analyzing BPAT productions of *Thunderstorm* from 1954 to the present, scholar Chen Jun has observed that:

All in all, the three BPAT productions of *Thunderstorm* from 1954-1979 were consistent in terms of their artistic treatment, such as in how they oriented the main subject of feudalism and in pursuit of realist style. At the same time, the surrounding eras, audience reception, and the artistic interpretations of the director and actors influenced the productions and gave rise to some clear differences...However, for the four later revivals of *Thunderstorm* (in 1989, 1997, 2000, and 2004), there were hardly any breakthroughs or developments in the style of performance, and the productions remained rooted in anti-feudalism and constrained by the framework of realist performance.¹⁰²

¹⁰⁰ Chen Yongxiang 陳永祥, “Leiyu de wutai huanjing 《雷雨》的舞台環境,” in *Leiyu de wutai yishu* 《〈雷雨〉的舞台藝術》, ed. Su Min 蘇民 et al. (Shanghai: Shanghai wenyi chubanshe, 1982), 325.

¹⁰¹ For example, Xia mentions some changes to Zhou Ping character. Xia Chun 夏淳, “Shenghuo Wei Wo Shiyi--Daoyan Leiyu Shouji 生活為我釋疑——導演《雷雨》手記,” in *Leiyu de wutai yishu* 《〈雷雨〉的舞台藝術》, ed. Su Min 蘇民 et al. (Shanghai: Shanghai wenyi chubanshe, 1982), 22.

¹⁰² Chen, *Xiju wenxue yu juyuan juchang*, 279–280.

This latter comment has, in fact, become a common complaint about the BPAT style of performance. In later years, when younger actors would take on roles from *Thunderstorm* and other BPAT classics like *Sunrise* or *Teahouse*, they would be required to study and imitate the gestures and vocal intonations of previous generations of actors who had played the same characters.¹⁰³ The past productions, once established as classics, replaced the literary text as scripts for future performances, and the reproduction of details in the “Stage Art” manuals perhaps contributed to this process.

Conclusion

Looking at the “Stage Art” volumes in light of their recent past and the known futures of the works represented therein, one can see a clear parallel with the artistic practices of the Cultural Revolution. *The Red Nose*, however, never entered the repertory of any major theater company in China. It was not reproduced in the manner of the BPAT classics, and in fact is rarely mentioned in genealogies of experimental theater. Therefore, if *The Stage Art of The Red Nose* is a blueprint, it has become a blueprint for a work of paper architecture. Alternately, we might also think of it as a theoretical text that suggests a vision of the theater—which in line with the discourse of the 1980s might be called “theatrical concepts” (*xiju guan* 戲劇觀)—that privileges acting technique as both process *and* performance. The ideal actor is one whose body works as a medium, both as a conduit to characterization and as one among many media employed onstage in service of the production.

¹⁰³ Avant-garde theater artist Li Yinan, who works with a theater group called the Cao taiban 草台版(Grass Stage), complains about precisely this problem in his essay “The Physical Body on the Grass Stage.” See Li Yinan, “The Physical Body on the Grass Stage,” in *The Body at Stake: Experiments in Chinese Contemporary Art and Theatre*, ed. Jörg Huber and Zhao Chuan, (Bielefeld: Transcript, 2013), 115.

The 1980s were a decade of competing impulses. On the one hand, the theater responded, at least early on, to ideological shifts by mirroring them in content and form. For example, plays about science and technology that showcased modernized staging technologies. On the other hand, this kind of plays never dominated the stage. In fact, there was a stronger pull in the opposite direction—to plays that foreground actor-audience interaction, the virtuosity of the acting body, a bare stage. These movements have largely been explained as appropriations of Western modernism coupled with a “root-seeking” return to the hallmark gestural language of the traditional Chinese theater. This is true, but what I have shown here is that neither technoscientific modernization nor the turn to Western modernism fully explain the preponderance of plays that explicitly foreground the theater-making process, and in particular, the focus on the acting body in performance that we see in the 1980s. Rather, I argue, these trends in the theater world respond primarily to the theatrical legacy of the Cultural Revolution, in particular its transformation of the theater into a technology of ideology and of technique into a means of biopolitical control. In this, it functions as a kind of “anti-technology” that pits the physical agency of the acting body against these darker legacies.

Chapter 4

The Aesthetics of Technological Excess: Innovation and Intervention in 21st-Century Chinese Theater

At the top of the Opening Ceremony of the 2008 Beijing Olympics, the entire Bird's Nest stadium went dark amid roaring cheers. Firecrackers ringing the stadium exploded in quick succession, then paused briefly as the image of a Chinese sundial appeared on a large screen suspended in the stands. When the bursts resumed, they followed a path from the sundial down to the middle of the field. There, as if ignited by the firecrackers, squares of LED light and a low rumbling sound radiated outward across the entire playing field. Up close, on large screens in the stadium and broadcasts around the world, one could see that the sound and light emitted from 2008 square drums and their drummers. From the perspective of the live audience seated far above the field, however, the flickering and pounding better resembled a matrix of glowing pixels. They blinked randomly at first, like the static noise on a malfunctioning television, but soon resolved into a carefully programmed display of flashing numbers. A digital clock, entirely made up of human actors and their lit drums, counted down the final seconds to the official start of the Games.

Beginning with this live digital clock, each segment of the Opening Ceremony proceeded to celebrate China's long history of innovation and showcase its contemporary capacities in the melding of performance and technology. Helmed by renowned film director Zhang Yimou 張藝謀 (b. 1951), the result was a stunning performance *of* technology structured around the "Four Great Inventions" of ancient China—paper, moveable-type printing, the compass, and gunpowder. Perhaps most impressive, and certainly most remarked-upon in media coverage of the event, was an enormous 147 meter-by-22 meter LED scroll that unfurled across the field.

During the performance, the screen alternated between the cool tones of traditional ink painting and vibrantly colored peach blossoms. Additional LEDs were installed throughout the Bird's Nest and sewn onto performers' costumes, while live feed from multiple cameras further immersed audiences in the show's "ideal multimedia environment," as commentators termed it.¹ From one perspective, the Opening Ceremony can be read as blatantly nationalistic spectacle, with China attempting to prove its prowess to the world via the flawless execution of a technically challenging program. As a theatrical production, however, it offers evidence of a more nuanced relationship between technological and artistic innovation, and of the melding of live performance *with* media and technology on a grand scale.

While far from theater proper, the large-scale performance at the Olympic Games nonetheless can be connected to the rise of what we might term an aesthetic of technological excess in 21st-century Chinese performing arts. Under this paradigm, technological innovation itself has become a key actor in live performance, sometimes employed to such an extent that it overwhelms or overshadows its human co-stars. Examples of this aesthetic beyond the Beijing Olympics Opening Ceremony can be found in incorporation of multimedia displays into state-sponsored song-and-dance propaganda performances and quasi-commercial "large-scale real-scene landscape performance" (*daxing shanshui shijing yanchu* 大型山水實景演出), bespoke outdoor sound-and-light shows created for famous tourist sites across the country. In more traditional theater venues and productions, the new century has also seen a veritable explosion in the number of theatrical productions in China that label themselves as "multimedia" (*duomeiti* 多媒體), "new media" (*xinmeiti* 新媒體) and "digital theater" (*shuma xiju* 數碼媒體 or *shuzi xiju* 數字戲劇). Like the Olympics and other large-scale performances, these productions rely

¹ "Beijing Conjures Olympic Opening Epic with High Technology," *Xinhua Net*, August 9, 2008, http://news.xinhuanet.com/english.2008-08/09/content_9067144.htm.

heavily on techniques such as LED lighting, live-feed cameras, and digital projection. This aesthetic of technological excess is one that caters both to today's media-immersed audiences and to the government's goal of transforming the country a leading science and technology innovator, even in the realms of art and culture.

Yet, while the technological excesses of large-scale spectacle have become ubiquitous in contemporary Chinese performance, they are not hegemonic. In fact, one might trace a parallel genealogy of the melding of multimedia technologies with live theater through the most avant-garde, even dissident, corners of the performing arts world. If in the 1980s the focus of many theater artists had been on reclaiming and redefining their art forms and the acting body in relation to technologies of ideology, by the 1990s a new theatrical vanguard had begun to experiment with incorporating different forms of media in live performance. More than a decade before Zhang Yimou made the leap from screen to stage, theater artists were already using techniques such as video projection, television sets onstage, and the manipulation of sound effects to critical ends in their work. In the 21st century, a new generation of directors has made a name for themselves by turning the very tools of technological excess back on themselves, questioning and critiquing the influence of new media and technology both in the arts and in Chinese society more broadly.

This chapter will investigate the emergence of and resistance to technological excess in contemporary Chinese theater, both mainstream and experimental. It centers on a set of questions raised by the different forms of multimedia theater found in China today. First, what is the relationship between large-scale multimedia performance, mainstream theater, and more experimental projects? Second, how do new innovations in multimedia performance change the relationship between live performance and spectators? Finally, how does the incorporation of

technologies of reproduction and mediation change not only the ecology of the theater world and spectator experience, but also the nature of the art form itself? These may not be new questions to the theater per se, but they take on new valences and urgency in the context of tech-obsessed 21st-century China.

In what follows, I address both questions and context by first outlining the circumstances that contributed to the rise of an aesthetic of technological excess in large-scale and mainstream Chinese performance, then providing specific case studies that complicate these categories and this dominant aesthetic. The opening section of this chapter begins with a discussion of the policies and politics that provided fertile ground for the creation and popularization of high-tech spectacles like the Beijing Olympics Opening Ceremony. Subsequent sections then focus on two contemporary theater directors, Wang Chong 王翀 (b. 1979) and Feng Jiangzhou 豐江舟 (b. 1966), who represent a more experimental and resistant strain of multimedia dramaturgy. Wang is an up-and-coming Beijing-based director best known for his use of video cameras and live-feed projection on stage, while Feng is a musician turned multimedia designer and director. Analysis of several of their key works reveals how they appropriate technologies shared with large-scale multimedia performance in the service of complicating and critiquing the theatrical tradition, aesthetic dominance of spectacle, and broader suffusion of technology in China today.

At the same time, both Wang Chong and Feng Jiangzhou have carefully positioned themselves within the existing domestic and international systems by taking on projects sponsored by government entities and collaborating with artists from Hong Kong, Taiwan, Japan, Europe, and North America. In its final section, therefore, this chapter shows how these artists employ multimedia technologies *and* the critique thereof in order to align themselves with the practices and politics of experimental performance outside of China. I argue that, by using

technology itself to negotiate the powers and discourses that typically instrumentalize art and artists, Feng Jiangzhou and Wang Chong successfully play the established system and make space for their own innovations, interventions, and artistic visions in a world dominated by more calculated applications of technology.

New Trends in Technology and the Arts

If modern Chinese writers once were afflicted with an “obsession with China,” as C.T. Hsia famously argued, contemporary Chinese society might be said to suffer from an obsession with technology. Science and technology, elided together as *keji* 科技 in contemporary Chinese parlance, have been a prominent part of China’s development platform since the end of the Cultural Revolution era. From the beginnings of reform in the late 1970s (see Chapter 3) to the 1988 Torch Plan, which offered government support for high-tech enterprises, to more recent policies promoting R&D, China has been striving for success—and international recognition—in a broad swath of scientific and technological fields for the past several decades.² For a time, a perceived lagging of innovation was chronically invoked as a source of concern vis-à-vis China’s future and additional motivation for exertions in these fields; more recently, Chinese leadership has praised successes in these areas for helping the country to weather the recent global economic crisis.³ The effects of technological development are most obvious in major cities like

² There is a truly extensive body of literature on the topics of science and technology in China, both premodern and modern, with a number of foundational studies on the PRC era published in the late 1980s. See for example Denis Fred Simon and Merle Goldman, *Science and Technology in Post-Mao China*, Harvard Contemporary China Series; 5 (Cambridge, Mass: Council on East Asian Studies, Harvard University, 1989); Tony Saich, *China’s Science Policy in the 80s*, Studies on East Asia (Atlantic Highlands, N.J.) (Atlantic Highlands, NJ: Humanities Press International, 1989). More recent studies tend to focus on specific industries, such as aviation, aerospace, communications, or computer technologies; one exception, which provides a broader outline from a policy perspective, is Varaprasad S. Dolla, *Science and Technology in Contemporary China: Interrogating Policies and Progress* (Delhi, India: Cambridge University Press, 2015).

³ This may yet be called into question, given the new concerns raised by the current state of the Chinese economy (as of early fall 2015). Wen Jiabao and Hu Jintao both stressed the importance of science and technology innovation

Beijing and Shanghai, where urban commuters ride shiny new mass transit while plugged into smartphones, giant screens take up prime real estate in locations like Tiananmen Square, and LED billboards light up the night skyline. Most recently, China has even made headlines for surpassing Silicon Valley in its development of mobile applications like WeChat (Weixin 微信), which combines social media profiles, messaging, video conferencing, photo sharing, online payments, and a number of other functions under one umbrella app.

In the last fifteen years, this spate of state-sponsored high-tech mania has spilled over into the world of theater and performance via the growth of institutional infrastructure and changes in national-level cultural policy. Most notable to the naked eye may be conspicuous construction projects such as the “egg” National Center for the Performing Arts (Guojia dajuyuan 國家大劇院), or NCPA, in Beijing, completed in 2007, the Hangzhou Grand Theater (Hangzhou Dajuyuan 杭州大劇院), completed in 2004, and Zaha Hadid’s Guangzhou Opera House (Guangzhou Dajuyuan 廣州大劇院), completed in 2010. These sleek new performing arts centers are outfitted with the latest in technical equipment and demonstrate the equal importance of grand edifice and state-of-the-art equipment to 21st-century state visions of the performing arts—a striking parallel to theater’s role in socialist construction during the first decade of the PRC, discussed in Chapter 2.⁴ Their lighting, sound, and state systems in these venues stand primed for

on multiple occasions, with Wen in particular linking innovation to continued development during the economic crisis. “Premier Wen Says Science, Technology Key to China’s Economic Development,” *China View News*, December 27, 2009, http://news.xinhuanet.com/english/2009-12/27/content_12711291.htm; Jane Qiu, “China’s Budget Backs Science,” *Nature* 483, no. 7389 (March 13, 2012): 258–258, doi:10.1038/483258a.

⁴ Technical specifications for theaters, both domestic and international, are often published in trade periodicals like *Yanyi keji* 《演藝科技》 (Entertainment Technology). See for example Jin Zhishun 金志舜, “Jianshe Zhong de Guojia Dajuyuan 建設中的國家大劇院,” *Yanyi keji* 《演藝科技》 1 (2004): 9–11. Theater websites will also sometimes proudly display their specs, as with the Dalian International Convention Center Grand Theater. See http://www.dlbiy.com/theatrefunction/dlbi_function. These projects, especially the ones designed by internationally acclaimed architects, have garnered significant attention from global news media. A Deutsche Welle documentary claims that 50 new opera houses have been built. “China’s Opera House Building Boom” *Deutsche Welle* July 29,

multimedia and moving scenery, and new arts research and development centers at state-sponsored institutions are working to provide content for them. The Shanghai Virtual Performance Lab (Shanghaishi duomeiti yanyi xuni kongjian hecheng zhongdian shiyan shi 上海市多媒體演藝虛擬空間合成重點實驗室) at the Shanghai Theatre Academy, for example, was established in 2006 and has designed a number of large-scale multimedia musical theater and dance performances since 2006.⁵ The Virtual Performance Lab also hosts academic conferences and publishes a journal called *E-yanju* 《E 演劇》 (E-Performing Arts). This and other new theater journals such as *Yanyi keji* 《演藝科技》 (Entertainment Technology), which began in 2004, feature both scholarly research on multimedia theater and reports on practical applications thereof, and contribute to further raising the profile of technical innovations in the theater and encouraging new developments.⁶ Yet, even so, there have been complaints that many of these theaters remain underused due to the technical knowledge required and the high costs associated with renting them. In her study of opera houses and concert halls, for instance, architectural historian Victoria Newhouse notes that theaters often remain dark for a year or more after

2013, <http://www.dw.com/en/documentaries-and-reports-documentaries-and-reports-2013-07-29/e-16941607-9799>. For a longer summary of the documentary, see also: <https://www.sfcv.org/article/chinas-opera-house-building-boom>. The NCPA was designed by French architect Paul Andreu, and also participates in a trend of internationally renowned architects taking major commissions in China. Anne-Marie Broudehoux, "Spectacular Beijing: The Conspicuous Construction of an Olympic Metropolis," *Journal of Urban Affairs* 29, no. 4 (October 1, 2007): 384, doi:10.1111/j.1467-9906.2007.00352.x; Victoria Newhouse, *Site and Sound: The Architecture and Acoustics of New Opera Houses and Concert Halls*, 1st ed. (New York: Monacelli Press, 2012), 174.

⁵ For summaries and photos of several of their projects, up to 2012, see Han Sheng 韓生, ed., *Shanghai shi duomeiti yanyi xuni kongjian hecheng zhongdian shiyan shi: shuzi yanchu yishu chuangzuo shiyan* 《上海市多媒體演藝虛擬空間合成重點實驗室：數字演出藝術創作實驗》 (Shanghai: Shanghai wenyi chubanshe, 2012).

⁶ *Entertainment Technology* was published under the title *Yanyi shebei yu keji* 《演藝設備與科技》 (Performing Arts Equipment and Technology) from 2004-2010. There are a few periodicals with longer publication histories, such as *Yishu keji* 《藝術科技》 (Art, Science, and Technology), which began publication in 1988. However, many of the theater- and performance-specific journals were not founded until the 2000s.

completion.⁷ In a similar vein, Beijing-based producer Alison Friedman has argued that the fees for spaces like the NCPA are prohibitive for smaller theater and dance troupes, and that this may be one factor limiting the performing arts sphere in China.⁸

On the level of cultural policy, the government since 2010 has also begun to explicitly call for advancement in the application of technology in arts and culture, broadly defined.⁹ This policy direction results from the joining of the longer-standing emphasis on science and technology with a new interest in “cultural and creative industries” (*wenhua chuangyi chanye* 文化創意產業) as a potential driver of economic growth.¹⁰ This cluster of “industries” includes advertising, architecture, the arts, the antique market, computer and video games, crafts, design, designer fashion, film and video, music, publishing, software, television and radio—and the performing arts.¹¹ Recent policies such as the “National Plan for the Advancement of Cultural Technologies” (Guojia wenhua keji tisheng jihua 國家文化科技提升計畫) and the “Ministry of Culture Technological Innovation Project” (Wenhuabu keji chuangxin xiangmu 文化部科技創新項目), advanced in 2012, target these industries and emphasize the importance of the fusion of culture and technology. In the performing arts, as one summary notes, plans emphasize in the need for further advances in stage sound and lighting and the use of digital and virtual

⁷ Newhouse, *Site and Sound*, 172.

⁸ Alison Friedman, “A New Regime,” *International Arts Manager* 10, no. 12 (December 2014): 37.

⁹ Zhonghua renmin gongheguo wenhuabu, ed., *Zhongguo wenhua nianjian 2012* 《中國文化年鑑 2012》 (Beijing: Xinhua chubashe, 2013), 327–333.

¹⁰ Sometimes referred to as “arts and cultural industries” (*wenhua yishu chanye* 文化藝術產業). Cultural industries were identified as a “pillar industry” (*zhizhuxing chanye* 支柱型產業) in the 12th Five-Year Plan (2011–2015).

¹¹ In addition, the Shanghai Theatre Academy has developed especially close ties to this new arena by establishing a Creative Industries Association (*Chuangyi chanye xiehui* 創意產業協會) in 2005. Li Wuwei, *How Creativity Is Changing China* (New York: Bloomsbury Academic, 2011), 2, 13.

technologies in order to “optimize the industry structure of the performing arts” and “improve the international competence of the performing arts.”¹² Such directives, as well as the high costs always associated with using the most cutting-edge equipment and systems, incentivize artists to seek both government support and international recognition for innovative projects.

As technology is applied to the performing arts, values from the technology industry—innovation, optimization, high performance—also seep into the goals of art. This melding of tech and art is displayed most prominently in large-scale performances sponsored by the government and more commercially inclined productions, such as the Beijing Olympics Opening Ceremony and “real-scene performances” at tourist destinations mentioned in the introduction to this chapter. This can be seen clearly from media coverage of the Opening Ceremony, which emphasized innovation in a way that blurred the distinctions between artistic and technological innovation.¹³ As one technical team leader, Yu Jianping, phrased it for a Xinhua News article: “We have combined creativity with the most complicated technologies in Olympic history to maximize the visual and sensory impact on the audience.”¹⁴ The same article also proudly reports the unprecedented number of LED beads incorporated into the performance (at a time when LED use in theatrical productions and digital billboards was only just beginning to go mainstream), and the use of materials originally developed for the space sector, as well as the role of domestic

¹² Hardy Yong Xiang and Hui Zhang, “Development Report on the Performing Arts Industry (2011-2012),” in *China Cultural and Creative Industry Reports 2013*, ed. Hardy Yong Xiang and Patricia Ann Walker, Understanding China (Heidelberg: Springer, 2014), 140. Cultural almanacs (*wenhua nianjian* 文化年鑑) published annually by the Ministry of Culture also contain details on planned programs and report their successes after implementation.

¹³ Mass media widely reported the details of the opening ceremony. The full four-hour production is available on DVD. *Aoyun qingdian: Beijing Aoyun huiyishi ji saishi zongshu* 《奧運慶典：北京奧運會儀式及賽事總述》 (Beijing: Beijing tiyu daxue chubanshe, 2010); Zhang Yimou 張藝謀 et al., *Beijing 2008 Aoyunhui kaimushi* 《北京 2008 奧運會開幕式》 (Beijing: Zhongguo guoji dianshi zonggongsi, 2008), DVD.

¹⁴ “Beijing Conjures Olympic Opening Epic with High Technology,” *Xinhua Net*, August 9, 2008, http://news.xinhuanet.com/english.2008-08/09/content_9067144.htm. Accessed September 12, 2015.

research and development in making possible the impressive production.¹⁵ Scholarly analysis, too, has commented on the combination of technology and art in the Opening Ceremony, especially the interaction between the human performers on “stage” and various special effects. In an article on the mediatization of the Beijing Olympics, for example, Francesca Sborgi-Lawson interprets the use of “live performers to ape computerized visual techniques” as a balancing of “live” and “mediatized”; for her, the human element is more compelling than the use of media.¹⁶ Likewise, Andy Rodekohr has discussed the masses of performers in the Opening Ceremony in relation to Zhang Yimou’s work in film, arguing that they constitute a distinctly *cinematic* effect deeply rooted in the technological means of reproducing the crowd onscreen.¹⁷ And indeed, techniques such as the use of drummers to create the impression of a digital clock, described above, and the coordination of 897 actors inside 897 larger-than-life moveable type blocks to ripple, wave, and resolve into the character for “peace” (*he* 和) suggest an almost flawless symbiosis between human artists, technology, and epic performance. This symbiosis even extended to spectators, as the mediatization of the spectacle through international television broadcast made it globally available for diverse interpretations, critiques, and remediation via network news replays and online video platforms.¹⁸

¹⁵ Ibid.

¹⁶ Francesca R. Sborgi-Lawson, “Music in Ritual and Ritual in Music: A Virtual Viewer’s Perceptions about Liminality, Functionality, and Mediatization in the Opening Ceremony of the 2008 Beijing Olympic Games,” *Asian Music* 42, no. 2 (2011): 14.

¹⁷ Andy Rodekohr, “‘Human Wave Tactics’: Zhang Yimou, Cinematic Ritual, and the Problem of Crowds,” in *Red Legacies in China: Cultural Afterlives of the Communist Revolution*, ed. Jie LI and Enhua Zhang (Cambridge, MA: Harvard University Press, 2016), 271–96.

¹⁸ For further discussion of how media actually created a diverse, heterogeneous viewing experience, see Sborgi-Lawson, “Music in Ritual and Ritual in Music,” 14–15.

In the Opening Ceremony, both special effects and the masses of performing bodies enacted the driving design concept of maximizing the “visual and sensory impact” of the production for audiences, near and far. The sheer number of performers—18,000 in all—even required the use of an aerospace monitoring system, the Shenzhou 4000, to track each of them and their positions on “stage” via unique identification codes.¹⁹ The tracking system confirms the extent to which the masses of performers in the Opening Ceremony were reduced to multiple media components of the larger performance machinery, while also hinting at more dystopian possibilities of surveillance and control shadowing the otherwise celebratory display of progress and peace found in the Opening Ceremony. The fact that this detail was reported so proudly, however, and as an indication of something never before done in an Opening Ceremony, primarily plays into the maximalist rhetoric surrounding the entire enterprise. Everything, it seems, was to be *more* or *better* than before, overwhelming the audience figuratively—as they were awed by the scope and scale of the performance—and literally—as the dizzying array of sights and sounds washed over them. Even the length of the program might be seen as a durational extension of this ethos. And rather than being a marker of waste, the excesses of this technological extravaganza, as Rodekohr terms it, were intentional and a point of pride for the nation.

Similar production values and forms of technological excess are also at work in the spate of real-scene performances that have been developed in China since 2004. In a rather different formulation than Richard Schechner’s concept of environmental theater, these productions take place in against the landscapes of famous tourist destinations.²⁰ Their focus is on the marriage—

¹⁹ “Beijing Conjures Olympic Opening Epic with High Technology.”

²⁰ In the “Six Axioms for Environmental Theater” section of *Environmental Theater*, Schechner does discuss the idea of technical elements becoming full performers in the theater. However, everything else, from creative process to politics, is far removed from the commercial-propaganda spectacles that are the *shijing yanchu*. See Richard Schechner, *Environmental Theater* (New York: Applause, 1994).

some might say marring—of natural scenery with sound-and-light spectacle and elements drawn from local culture.²¹ This genre of performance shares a lineage with the Olympics Opening Ceremony through their lead creative director, Zhang Yimou, who inaugurated the real-scene performance trend in 2004 with his *Yinxiang Liu Sanjie* 《印象劉三姐》 (Impression Liu Sanjie) in Guilin 桂林. Since 2004, Zhang and his collaborators, theater directors Wang Chaoge 王潮歌 and Fan Yue 樊越, have developed nine additional productions in their “Impressions Series” (*Yinxiang xilie* 印象系列), and a number of other directors have developed similar shows under other branding.²² As one description from the Series website puts it:

From the artistic perspective, the Impression Series have inaugurated a brand-new form of ‘real-scene performance.’ A new concept of performing arts, the real-scene performance embroiders and sublimates real mountains, real waters, real life and real sentiments in a way that transforms them into the art of visual pleasure; it is of irreplaceable uniqueness because of its arenas created based on real natural environments, its source material derived from local culture, life and customs, and its combination with characteristic music.

‘實景演出’是演出藝術的全新理念，她將真山，真水，真生活，真情感渲染，昇華，將視覺納入審美的境界，轉化為藝術。實景演出把真實的地貌環境轉化為演出

²¹ A number of articles have been written in Chinese about this type of performance, especially in relation to tourism and cultural industries. See for example: Zheng Yan 鄭焱, Liu Xiaotong 劉小同, and Xu Chunxiao 許春曉, “Shijing yanchu youke ganzhi, qinggan, manyi de guanxi tanjiu 实景演出游客感知、情感、滿意的关系探究,” *Luyou yanjiu* 《旅遊研究》 5, no. 2 (2013): 42–49.

²² The Impressions Series also includes: *Yinxiang Lijiang* 《印象麗江》 (Impression Lijiang, 2006) in Yunan, *Yinxiang Xihu* 《印象西湖》 (Yinxiang West Lake, 2007) in Hangzhou, *Yinxiang Hainandao* 《印象海南島》 (Impression Hainan Island, 2009), *Yinxiang Dahongpao* 《印象大紅袍》 (Impression Dahongpao, 2010) at Mount Wuyi, *Yinxiang Putuo* 《印象普陀》 (Impression Putuo, 2010), *Yinxiang Wulong* 《印象武隆》 (Impression Wulong, 2011) near Chongqing, and *Yinxiang guoyue* 《印象國樂》 (Impression Chinese Music, 2013). *You jian Pingyao* 《又見平遙》 (Encore Pingyao, 2013) and *You jian Wutaishan* 《又見五台山》 (Encore Mount Wutai, 2014) in Shanxi are included as part of the series, as well, and were produced by the Impressions Wonders Arts Development Company, but the omission of the term *yinxiang* (impression) from the titles signals that Wang Chaoge, Zhang Yimou’s collaborator, directed (rather than Zhang himself). An additional production, *Yixiang Malujia* 《印象馬六甲》 (Impression Malacca), which is to take place in Malaysia and be the first international production in the series, was postponed following the disappearance of Malaysian Airlines Flight 270 in 2014.

場地，把當地的人文和日常生活生產，民宿民風等轉化為藝術素材，結合特有的現實音樂，使這場藝術的盛典，具有不可複製的唯一性。²³

The description goes on to claim that the directors have also “invented a range of new technologies for stage performance, for example, 360-degree stage rotation and matrix real-scene cinematography (360du wutai xuanzhuan jishu, juzhen shijing dianying 360 度舞台旋轉技術，矩陣實景電影)—both unprecedented in the country.”²⁴ As film scholar Audrey Yue notes in her discussion of the Impressions Series, several of the productions employ large-screen technologies, from image projection directly onto natural landscapes to LED screens embedded within them.²⁵ Thus, just as the Olympics Opening Ceremony displayed a symbiosis of performers, technology, and art, so too do the Impressions and like real-scene performances aim for the unity of natural beauty, human talent, and technological innovation. Innovation also becomes more directly commodified in these productions, as the novelty of new technical tricks functions as a major draw for audiences. Moreover, their success as a “series” is predicated upon their status as reproducible objects. The model of *Impression Liu Sanjie*, in theory, works equally well when applied to West Lake or Mount Wutai.

If in one direction these performances act upon their environments to “sublimate” them into “art,” then in another they also work on their audiences to immerse them as fully as possible—visually and aurally, physically and emotionally. Here, too, technology is key. If we take, for example, one of the most popular Impressions, *Yinxiang Xihu* 《印象西湖》

²³ Translation taken from original bilingual text. “Guanyu Yinxiang 關於印象 (About Impression),” *Guan Yinxiang*, accessed October 10, 2015, <http://www.guanyinxiang.com/about.html>.

²⁴ Translation taken from original bilingual text. *Ibid.*

²⁵ Audrey Yue, “New Media: Large Screens in China,” in *The Oxford Handbook of Chinese Cinemas*, ed. Carlos Rojas and Eileen Cheng-yin Chow (Oxford: Oxford University Press, 2013), 367.

(Impression West Lake), we find the site of many famous Chinese folktales and works of poetry—the West Lake, in Hangzhou 杭州—transformed into a stage, with audience members seated on one shore. Throughout the performance, dozens of performers seem to dance on water, skimming effortless across platforms hidden underwater. At times, the stage machinery itself becomes an actor, lifting up out of the lake to a towering height and raining sheets of water onto those below. Projection and candy-colored lighting wash across the natural landscape as if it were a screen or, as Yue has argued in relation to other Zhang Yimou productions, a “media skin.”²⁶ Meanwhile, headphones playing a soundtrack composed by Japanese new age musician Kitarō 喜多郎 (Takahashi Masanori 高橋正則) further submerge spectators in this technologically enhanced landscape, filtering out “real” noise and adding an audio component to visual spectacle.²⁷ The “embodied technologization” of headsets may be read alternately as creating an individualized, effectively neoliberal, subject, as has been discussed by Shuhei Hosokawa, Rey Chow, and others, or as allowing for “an interactive experience that can potentially enhance collective place-making,” as Yue contends.²⁸ However, in the context of large-scale multimedia performance, I argue that we must understand the use of headphones as part of the aesthetic of technological excess at work in these productions; by immersing the individual spectator more fully, the headphones contribute to the overall sensory oversaturation that is produced by their combination of audio-visual stimuli.

²⁶ Ibid., 366–368.

²⁷ The album *Impressions of the West Lake* by Kitarō was nominated for a Grammy Award for Best New Age Album in 2009.

²⁸ Hosokawa coins the term “the Walkman Effect” in a 1984 article. Rey Chow analyzes the Walkman in the Chinese context in *Writing Diaspora: of Intervention in Contemporary Cultural Studies*, and Audrey Yue references Chow in her discussion of screen culture in contemporary China. See Shuhei Hosokawa, “The Walkman Effect *,” *Popular Music* 4 (1984): 165–80, doi:10.1017/S0261143000006218; Rey Chow, *Writing Diaspora: Tactics of Intervention in Contemporary Cultural Studies*, Arts and Politics of the Everyday (Bloomington, IN: Indiana University Press, 1993), 161–164; Audrey Yue, “New Media: Large Screens in China,” 370.

As the Impressions Series and like productions have grown in number, popularity, and profile, they have come to represent a dominant, politically and commercially sanctioned mode of multimedia performance in the PRC—one that relies, above all, on technological and sensory excess to attract and impress their audiences.²⁹ The involvement of major cultural figures like Zhang Yimou and widespread media coverage places this trend at the heart of mainstream culture and disseminates its aesthetics far beyond the already large live audiences. These productions may not always take place in the theater per se, but they often involve leading figures in from the theater world and are unquestionably theatrical in their staging of Chinese culture and technological prowess. In addition, they have had real influence in the theater world. Today, it is common to find LED screens or large scale projection integrated into scenography, and new productions at major venues like the NCPA not infrequently list a multimedia designer (*duomeiti sheji* 多媒體設計) in their program credits. An even more direct link can be found in Chinese scholarly articles and news reports that identify the Opening Ceremony of the 2008 Beijing Olympics as a factor in an overall increase in the profile of multimedia theater in the PRC and the growing application of specific new technologies, like large-scale LED lighting and circular surround screens, in theatrical design.³⁰ Examples of this trend can be found in productions such as the opera *Shancun nü jiaoshi* 《山村女教師》 (The Village Teacher, 2009), which was performed at the National Center for the Performing Arts with a 50-meter-by-14-meter curved screen (*huanmu* 环幕). Reviews of the production noted the astounding scenic

²⁹ Parallel trends in commercial theater and performance exist worldwide. For discussion of additional examples in East and Southeast Asia, see John A. Williams, “Lighting Spectacles in East and Southeast Asia,” *Asian Theatre Journal* 31, no. 2 (2014): 594–605.

³⁰ He Pu 何璞, “Duomeiti zai xiju zhong de chuanyi biao xian 多媒體在戲劇中的創意表現,” *Yunnan yishu xueyuan xuebao* 《雲南藝術學院學報》 4 (2010): 60.

design and visual effects, and specifically linked the screen to a similar screen ringing the Bird's Nest Olympic Stadium during the Opening Ceremony.³¹

All of this is what has been identified as part of a more widespread multimedia or “intermedial” turn in the Chinese theater world in the first decades of the 21st century. But what of more independent artists and smaller scale productions? In fact, it might be argued that the use of screens, projection, and other technologies has a parallel genealogy in the more dissident corners of the 1990s Chinese avant-garde. As Rossella Ferrari has discussed in *Pop Goes the Avant-Garde: Experimental Theater in Contemporary China*, leading directors such as Lin Zhaohua 林兆華 (b. 1936) and Meng Jinghui 孟京輝 (b. 1964) began to experiment with the use of video projection onstage as early as the mid-1990s. The earliest instance of screens and video cameras onstage may be found in Lin's *93 xiju kala OK zhiye* 《93 戲劇卡拉 OK 之夜》 (93 Nights of Theatrical Karaoke), which premiered at the Beijing People's Art Theater (Beijing *remin yishu ju yuan* 北京人民藝術劇院) in 1993.³² Similar technologies appear in the 1994 premiere of *Wo ai XXX* 《我愛 XXX》 (I Love XXX), directed by Meng Jinghui, which featured slideshows, soundtracks, and film as a reflection of contemporary, mediatized society.³³ Even more radical experiments took place in the work of Mou Sen 牟森 (b. 1963) and documentary filmmaker Wu Wenguang 吳文光 (b. 1956), whose collaboration on *Ling dang'an* 《0 檔案》 (File Zero, 1994), for example, offered a sharp, critical take on the theme of human

³¹ Zhang Xuejun 張學軍, “*Shancun nü jiaoshi wutai xiaoguo bizhen, shanhong baofa shenlinqijing* 《山村女教師》 舞台效果逼真, 山洪暴發身臨其境,” *CCTV Entertainment*, December 18, 2009, <http://ent.cctv.com/20091218/102095.shtml>.

³² Ferrari, *Pop Goes the Avant-Garde*, 63.

³³ *Ibid.*, 194.

vs. industrial machine and could not even be staged in China.³⁴ These experiments paved the way for the more widespread application of multimedia the performances starting in the middle of the next decade, when additional inspiration also arrived via touring foreign productions. Two key examples of this are the Station House Opera production of *Roadmetal, Sweetbread*, which toured to Shanghai in 2001 and to Beijing in 2004, and *Leitmotiv* by Les Deux Mondes, which performed at the 5th Shanghai International Arts Festival in 2003.³⁵ The use of screens onstage and relationship between the filmed, projected images and live actors in both productions drew excited commentary from Chinese reviewers, with several articles noting that these techniques were still relatively new to Chinese audiences. News media and scholarly articles would also often introduce multimedia theater experimentation in China via a genealogical discussion of multimedia in famous Western productions, such as *Einstein on the Beach*.³⁶

Given these connections, it is tempting to link smaller scale techno-artistic innovation to a subversive political agenda. However, this has hardly proved the case. For example, as Rossella Ferrari has discussed at length in *Pop Goes the Avant-Garde*, Meng Jinghui has since the turn of the 21st century become the paradigmatic example of what she terms China's "pop avant-garde." His work, once on the fringe of the Beijing theater world and the edge of political acceptability, has exploded in popularity and transformed him into a mainstream, establishment figure who does as much work for his official job with a major state-sponsored theater company

³⁴ *File Zero* premiered at the Kunsten Festival des Arts in Brussels in May 1994. See Denis Salter, Mou Sen, and Wu Wenguang, "China's Theatre of Dissent: A Conversation with Mou Sen and Wu Wenguang," *Asian Theatre Journal* 13, no. 2 (1996): 218–28, doi:10.2307/1124526.

³⁵ Ma Yuchao 馬昱超, Wei Jie 魏捷, and Cao Xiaolei 曹小磊, "E'meng chuxing--duomeiti xiju *Tianhua yu regou* 噩夢初醒——多媒體戲劇《天花與熱狗》," *Wenhua yuekan* 《文化月刊》 4 (2001): 62–65; Zhou Chunyu 周春雨, "Ganshou duomeiti xiju de zhenhan 感受多媒體戲劇的震撼," *Shanghai xiju* 《上海戲劇》 10 (2003): 13–14.

³⁶ See for example Yi Hongxia 易紅霞, "Shuma shida de xiju, qi Weiji, shengji yu duomeiti xingtai 數碼時代的戲劇, 其危機, 生機與多媒體形態," *Zhongguo xiju* 《中國戲劇》 8 (2004): 6.

as he does on his own. This transition has in turn made the aesthetic that he developed in his more radical days influential and more accepted at least among young, urban audiences.³⁷ In addition, as discussed above, there is an uneasy continuity between the technologies that he and others premiered in the early 1990s and the large-scale multimedia performances of the 21st century. Indeed, it is almost as if the more spectacular the technology, the more easily it seems to have lent itself to appropriation in the service of displaying state and Party power and national prowess vis-à-vis an international audience.

The contrast between the previous decade's more dissident multimedia theater and the contemporary mainstream raises questions regarding the evolving relationship between the two. What is the relationship between large-scale "performances," such as those described above, and the theater proper? How do directors beyond Meng Jinghui and Zhang Yimou navigate the current landscape and negotiate the competing demands of Party, art, and market? Scholars of contemporary Chinese theater and culture, such as Geremie Barmé, Claire Conceison, Rossella Ferrari, and Jing Wang, have convincingly demonstrated that there is no easy binary between state-controlled, propagandistic uses of art and more experimental, potentially subversive, work in the PRC.³⁸ But what, if any, changes come as these various spheres of interest align under the imperatives of new media and technologies? That is to say, as political, artistic, and commercial agendas turn to very similar applications of multimedia technologies, how do we understand the

³⁷ It is also important to note, as Ferrari and Conceison do, that Meng was never entirely outside of the system, even when his work was more classically "avant-garde." He was trained at the state-sponsored Central Academy of Drama and his official work unit is the National Theatre Company of China (Zhongguo guojia huaju yuan 中國國家話劇院), formerly the Central Experimental Theatre Company (Zhongyang shiyan huaju yuan 中央實驗話劇院).

³⁸ Geremie Barmé, *In the Red: On Contemporary Chinese Culture* (New York: Columbia University Press, 1999); Claire Conceison, "China's Experimental Mainstream: The Badass Theatre of Meng Jinghui," *TDR - The Drama Review* 58, no. 1 (2014): 64–88; Rossella Ferrari, "The Avant-Garde Is Dead, Long Live the (Pop) Avant-Garde! Critical Reconfigurations in Contemporary Chinese Theatre," *Positions: East Asia Cultures Critique* 20, no. 4 (2012): 1127–57; Jing Wang, *High Culture Fever: Politics, Aesthetics, and Ideology in Deng's China* (Berkeley: University of California Press, 1996).

works that result in relation to one another and to their audiences? When spectacular technologies trickle down into other modes of performance, what new possibilities open up? What, if any, resistance has there been to this excessive mode? This set of questions becomes all the more pressing as global communities of theater artists and global audiences grow increasingly interested in China, bringing new opportunities for collaboration, new imperatives to create work that is legible to broader audiences, and new financial incentives for Chinese theater makers.

These questions are relevant because, even as the state has perfected the art(ifice) of multimedia performance, theater makers in China continue to experiment with more artistic and critical applications of similar technologies onstage. In these works, the problematic tensions that are glossed over in more spectacular performances come to the fore, as theater makers actively engage them and encourage their audiences to do the same. The following sections will introduce two contemporary theater makers, Wang Chong and Feng Jiangzhou, who work within the mode of multimedia theater and address precisely these issues within their work itself, in their artistic praxis, and in their attitude toward their audiences.

*Generation XXX: Wang Chong and Technology Critique*³⁹

Wang Chong belongs to a young generation of mainland Chinese theater artists who grew up in a globalizing world, trained abroad, and been able to see a range of international productions both at home and in New York, London, Avignon, Edinburgh. A child of the post-80 generation (born in 1982), Wang did not graduate from one of the PRC theater conservatories, like the Central Academy of Drama or the Shanghai Theater Academy. Instead, after attending the

³⁹ The title of this section puns on the title of *Wo ai XXX* 《我愛 XXX》 (I Love XXX), directed by Meng Jinghui. An English translation is forthcoming in *I Love XXX and Other Plays*, ed. and trans. Claire Conceison (Chicago: University of Chicago Press, forthcoming December 2016).

prestigious Peking University, he built his theater credentials by studying for an MA at the University of Hawai'i, completing a year of PhD coursework at UC Irvine, and working with well-known directors like Lin Zhaohua and Robert Wilson. He has participated in programs such as the Beijing Fringe Festival, which is headed by Meng Jinghui, but is not employed by any state-sponsored theater companies. Instead, he founded his own troupe, *Xinchuan shiyan jutuan* 薪傳實驗劇團 (Théâtre du Rêve Expérimental) in 2008 and his work has come of age during precisely the period that large-scale multimedia performance has risen to the fore in mainland China. And it is for Wang's own use of multimedia, albeit on a smaller and decidedly more critical scale, that he has received local critical acclaim and international attention.

In particular, Wang has become known for his signature use of video cameras and live-feed projection onstage. He began to develop this technique while at the University of Hawai'i. There, he created a production entitled *Hamletism*, which featured pre-recorded video projection and used Shakespeare's *Hamlet* as a springboard to explore the isolation of the individual in a technology-infused world.⁴⁰ *e-Station*, his third show, took this theme a step further by placing actors amidst a literal tangle of wires, cords, and various electronics onstage.⁴¹ Responding to one interviewer's inquiry about the production's comparison of electronics to body parts, Wang stated:

⁴⁰ Joseph T. Rozmiarek, "A Melancholy Dane, Indeed," *The Honolulu Advertiser*, March 22, 2006, <http://the.honoluluadvertiser.com/article/2006/Mar/22/en/FP603220307.html>.

⁴¹ Wang discussed his motivations for staging *e-Station* with China Radio International (Zhongguo guoji guangbo tai 中國國際廣播電視台) journalist Yuan Teng 袁騰 on September 12, 2008. A transcript of the conversation is included on the Théâtre du Rêve Expérimental website at: <http://hanenaka.wix.com/theatre-du-reve#!20080912/c1jjw>. Reviews of a version staged at the New York Fringe Festival in 2009 were published by NYTheatre.com, the *Village Voice* and CurtainUp.com. I also saw a touring version of this production at the Edinburgh Fringe Festival in 2012. See Jim Felton, "e-Station," *Nytheatre.com*, August 22, 2009, <http://www.nytheatre.com/Review/will-fulton-2009-8-22-e-Station>; Miriam Felton-Dansky, "Fringe Festival 2009 Reviews," *Village Voice*, August 11, 2009, <http://www.villagevoice.com/arts/fringe-festival-2009-reviews-7134486>; David Lipfert, "A CurtainUp Report: 2009 New York International Fringe Festival," *CurtainUp*, August 31, 2009, <http://www.curtainup.com/fringe09.html>.

It's different from the way we used electric lights when electricity was first invented; now, cellphones have already become a part of our bodies. At the same time, it's also different from how we used electricity to alter the world around us; now, it's people's bodies that have been fundamentally changed. If we don't grab our cellphones when we go out, we feel very anxious, as if we've lost one of our own organs; we feel incomplete.

這跟電發明之初我們使用電燈不同，現在，手機已經進入了人的身體；同時也跟人借助電來改造世界不同，現在是人的身體本身被改變了。如果你沒帶手機出門，會很焦慮，感覺像是自己的一個身體器官丟了，感覺的人的功能不齊全了。⁴²

Wang's comments echo Marshall McLuhan's well-known claim that media is the "extension of man" and offer an interesting rejoinder to efforts to draw a hard line between the live and the technologized; both in real life and onstage, bodies have already become intimately entangled with technology.⁴³ However, as the ambivalent reviews of both of these pieces note, Wang's early forays into theatrical critique of this 21st-century condition leave something to be desired in their rather unsubtle treatment of the theme.

In his productions of *PekingOperatION* and Heiner Muller's post-modern deconstructed *Hamletmachine* in 2010, we begin to see Wang Chong's multimedia critique find its target: the Chinese theatrical tradition.⁴⁴ Here, we find nothing of the simulacra of national history and local culture staged by the Olympics Opening Ceremony or the Impressions Series. Rather, we see his increasingly media-rich work engage, deconstruct, and piece back together styles and specific dramatic pieces that have exerted a strong and ongoing influence on contemporary Chinese

⁴² Wang Chong 王翀, Beijing qingnian xijuji tiebie jiemu 北京青年戲劇節特別節目, interview by Yuan Teng 袁騰, China Radio International (Zhongguo guoji guangbo tai 中國國際廣播電視台), September 12, 2008, <http://hanenaka.wix.com/theatre-du-reve#!20080912/c1jjw>.

⁴³ See Marshall McLuhan, *Understanding Media: The Extensions of Man*, 1st MIT Press ed. (Cambridge, Mass: MIT Press, 1994).

⁴⁴ Wang Chong also made a name for himself directing a the Chinese premiere of Eve Ensler's *The Vagina Monologues* in 2009, rebranded as *V dubai* 《V 獨白》 to appease the censors. A previous attempt at a profession production of *The Vagina Monologues* in 2004 ended with the play being banned before it could open. Julian Baird Gewirtz Rhodes, "The Vagina Monologues Comes to Beijing," *The Huffington Post*, April 17, 2009, http://www.huffingtonpost.com/julian-baird-gewirtz/the-vagina-monologues-com_b_175031.html.

theater. At times, this critique is trained on *jingju*: in *Hamletmachine* and *Peking OperaTION*, Wang Chong worked with young *jingju* actors to combine “physical theater” with “traditional Chinese drama.”⁴⁵ The production of *Hamletmachine* also featured recorded monologues of Hamlet and Ophelia and large-screen projections. To be sure, the reworking of *jingju* via either Shakespeare or postmodern aesthetics and the introduction of media elements to *xiqu* performances is nothing new; what Wang Chong does in these performances, however, is mount a deconstruction of *jingju* in which *jingju* reform or innovation is hardly the point.⁴⁶ As the title of the latter production suggests, *jingju* for Wang Chong is a tool, instrumentalized into a scalpel for the dissection and repair of an ailing theatrical body. The underlying ailment becomes clear from a *China Daily* article written at the time of the performances, in which Wang Chong describes his inspiration for the two productions as follows: “Text is unimportant as stage performance is the core of theater...I like physical theater which is a big departure from traditional Chinese drama. Mainstream Chinese drama depends on dialogue. But that is just like karaoke, one only has to recite the lines.”⁴⁷ This comment reveals Wang’s desire to push Chinese theater in the direction of the post-dramatic theater, a term coined by German theater scholar Hans Lehmann to describe the trend of a departure from text seen in European theater since the 1970s (and which was first translated into English at precisely the moment Wang Chong attended graduate school, 2006).⁴⁸ Moreover, his particular emphasis on *text* and *dialogue* lead

⁴⁵ Xu Lin, “Pushing the Boundaries,” *China Daily*, September 25, 2010, http://www.chinadaily.com.cn/life/2010-09/25/content_11343867.htm.

⁴⁶ For discussion of Shakespeare adapted for *jingju*, see for example select chapters in Alexander C. Y. Huang, *Chinese Shakespeares: Two Centuries of Cultural Exchange*, Global Chinese Culture (New York: Columbia University Press, 2009); Ruru Li, *The Soul of Beijing Opera: Theatrical Creativity and Continuity in the Changing World* (Hong Kong: Hong Kong University Press, 2010).

⁴⁷ Here, Wang refers not to *xiqu* but to the tradition of *huaju* in China. Xu Lin, “Pushing the Boundaries.”

⁴⁸ Hans-Thies Lehmann, *Postdramatic Theatre*, trans. Karen Jürs-Munby (New York: Routledge, 2006).

into his next experiments, which target *huaju*—“spoken” drama—via a reworking of playwright Cao Yu’s canonical *Thunderstorm* as *Thunderstorm 2.0*.

Premiered in Beijing in July 2012, *Thunderstorm 2.0* pares Cao Yu’s 1934 play down to three main characters—two women and a man who loosely map onto the original characters of Zhou Ping, Fanyi, and Sifeng—and transposes its setting to the year 1990.⁴⁹ The original play involves an incestuous love triangle between Zhou Ping, his stepmother Fanyi, and his secret half-sister Lu Sifeng and unfolds in an appropriately melodramatic fashion; in Wang Chong’s deconstructed version, the incestuous element is removed while the love triangle remains. As in the original, one female character is a servant, and the two women come share a lover in the main male character; the nonlinear action of the play revolves around their mutual discovery of his infidelity and betrayal. Little else in the production resembles the play as originally written, although Wang was also careful to remind reporters and reviewers that they obtained the approval of Cao Yu’s daughter for the adaptation and did pay royalties for their use of the script—a somewhat paradoxical gesture given his anti-textual stance.

In his production of *Thunderstorm 2.0*, Wang Chong subverts the Chinese theatrical tradition through three key interventions into the text and performance of *Thunderstorm* that work on the levels of script, staging, and audience reception. Indeed, Wang is quite self-conscious about his desire to be subversive in this way; in a *Xin jing bao* 《新京報》 (New Beijing Daily) article about the piece, he is quoted saying:

I am not content with the fact that Hamlet can be performed in endless ways, but there is only one way to do *Thunderstorm*. All of the productions of *Thunderstorm* are largely the same, with few differences, and this time I wanted to subvert the roots of the *huaju* art

⁴⁹ All descriptions of the production that follow are based on a recording of the production as staged at Beijing’s Muma juchang 木馬劇場 (Trojan Horse Theatre) in July 2012. My thanks to Wang Chong and Théâtre du Rêve Expérimental for providing me with the recording.

form, bid farewell to tradition, remold one of the masters, and transform Cao Yu from a ‘dramatist’ into a ‘poet’.

我不滿足於為什麼《哈姆雷特》可以有無數版本，《雷雨》卻只有一種演法。以往《雷雨》的演出都大同小異，我這次是要顛覆話劇藝術的根，告別傳統，重塑大師，讓曹禺從‘戲劇家’成為‘詩人’。⁵⁰

On the one hand, Wang follows in the vein of American playwright Charles Mee, whose “(re)making project” transforms the poetry of ancient Greek drama into postmodern plays and makes them available online.⁵¹ On the other, we can also read his work as responding to the reproducibility of theater observed in large-scale multimedia performance “series” and, as Chong notes, in the codification of production practice represented by *Thunderstorm*.

At the level of text, Wang Chong employs the now familiar technique of dismantling an original text and recombining it in new and surprising ways. All of the lines spoken onstage in *Thunderstorm 2.0* come from Cao Yu’s play, but they are broken up and disassociated from the characters who speak them in the original text. For example, *Thunderstorm 2.0* opens on a party, with the Beach Boys’ “Wouldn’t It Be Nice” (1966) playing in the background, and guests swapping pieces of lines excerpted from a scene in Act I of *Thunderstorm*.⁵² In the original script, the scene unfolds as follows:

⁵⁰ Chen Ran, “*Leiyu 2.0* dianfu Cao Yu 《雷雨 2.0》顛覆曹禺” *Xin Jing Bao* 《新京報》 July 12, 2012, <http://hanenaka.wixsite.com/theatre-du-reve/20120712>

⁵¹ Wang Chong’s quotation of computer software rhetoric—“version 2.0”—is very similar to the title of some of Mee’s plays, such as *The Bacchae 2.1* and *Iphigenia 2.0*. Mee does not universally title his works in this way, and some of his pieces target traditions other than the ancient Greek. *Utopia Parkway*, for example, is based on the Yuan dynasty playwright Guan Hanqing’s 關漢卿 *Dou’E Yuan* 《竇娥冤》 (Injustice to Dou’E). For more on Mee and the (re)making project, visit <http://www.charlesmee.org/>. However, Wang claims that although he is aware of Mee’s work, he does not know much about it and it was not a particularly strong influence. Interviews with Wang Chong, January 15, 2015.

⁵² More than one article on the production notes this particular detail, suggesting that Wang Chong may have mentioned it in an interview or talkback session. Du Puhua 杜晋华, “Huaju? Dianying? Geming? 话剧? 电影? 革命?” *Jingpin gouwu zhinan* 《精品购物指南》 July 19, 2012, <http://hanenaka.wixsite.com/theatre-du-reve/20120719>; Chen Ran, “*Leiyu 2.0* dianfu Cao Yu.”

Zhou Fanyi (*protesting*): I won't touch it—it's too bitter.

Zhou Puyuan (*to LU SIFENG, raising his voice*): Go on.

(LU SIFENG *walks across to the left and pours the medicine into a small bowl.*)

Zhou Chong: But Father! If Mom doesn't want it, there's no need to force her to take it.

Zhou Puyuan: Neither you nor your mother knows what's wrong with either of you. (*to his wife, in a low voice*) Come now, it'll make you quite well again if you'll only take it. (*Seeing that LU SIFENG seems still undecided, he points to the medicine bowl*) Hand it to the mistress.

Zhou Fanyi (*forcing herself to yield*): All right. Put it down here for the moment.

Zhou Puyuan (*with annoyance*): Nope. You'd better take it at once.

Zhou Fanyi (*bursting out*): Sifeng, take it away!

Zhou Puyuan (*with sudden harshness*): Take it, I say! Don't be so headstrong. And in front of these grown-up children, too!

Zhou Fanyi (*her voice trembling*) But I don't want it.

周繁漪（反抗地）：我不願意喝這種酷東西。

周樸園（向四鳳，高聲）：倒了來。

（四鳳走到左面倒藥。）

周冲：爸，媽不願意，您何必這樣強迫呢？

周樸園：你同你母親都不知道自己的病在哪兒。（向繁漪低聲）你喝了，就會完全好的。（見四鳳猶豫，指藥）送到太太那裡去。

周繁漪（順忍地）好，先放在這兒。

周樸園（不高興地）：不。你再好現在喝了它吧。

周繁漪（忽然）：四鳳，你把它拿走。

周樸園（忽然嚴厲地）：喝了它，不要任性，當著這麼大的孩子。

周繁漪（聲顫）：我不想喝。⁵³

Here, the husband, Zhou Puyuan, attempts to coax (or coerce) his wife, Fanyi, into drinking a medicinal brew that her maid, Sifeng, prepares with the Zhou's younger son Chong looking on. The scene continues beyond this excerpt, with Zhou Puyuan manipulatively forcing his son to kneel and beg his mother to obey his father, and the battle of wills between family patriarch and “hysterical” second wife is one of the most powerful scenes in Cao Yu's melodrama. Wang

⁵³ Cao Yu, “Thunderstorm,” 192; Cao Yu 曹禺, “Leiyu 《雷雨》,” in *Cao Yu quanji* 《曹禺全集》, ed. Tian Benxiang 田本相 and Liu Yijun 劉一軍, vol. 1 (Shijiazhuang: Huashan wenyi chubanshe, 1996), 65–66.

Chong's version, however, neither Zhou Puyuan nor Zhou Chong makes an appearance, and their lines are barely recognizable. Instead, the context has shifted to two men and a woman holding glasses of alcohol in an apartment living room, and the words are fragments: "Just drink it." "I don't want to." Were it not for the live-feed camera projecting a close-up of these three actors onscreen, the audience might not even know that these scant lines were an allusion to one of *Thunderstorm*'s most iconic scenes.

Reducing an original text to fragments and recoloring a climactic, melodramatic scene with the buoyant nonchalance of the Beach Boys might be seen as a textbook case of postmodern or postdramatic theater—a rather cliché method of achieving the main goal of the piece, in fact. However, as discussed in Chapter 3, *Thunderstorm* is not solely a classic modern dramatic literature in China, but also a classic of performance. The trend that began in the 1980s has continued into the 21st century, with the BPAT stagings now cemented under several decades of codified performances. The tradition of print reproduction also continues, with new versions of the "Stage Arts" series recently released under the imprint of the BPAT Theater Museum. Beautifully bound and on sale at the gift store on the first floor of the Capital Theater, along with DVDs, these new volumes allow audience members to take the performance home with them. They resemble souvenir Broadway production volumes filled with glossy photos and behind-the-scenes stories, like the *RENT* tome or the recently released *Hamilton: the Revolution*. That is to say, they make codification into something worth commemorating.

In a world in which a particular style of performing *Thunderstorm* has become definitive and codified, the fragmentation in *Thunderstorm 2.0* offers a kind of democratization wherein Cao Yu's hallowed lines become newly open to being re-cited by anyone onstage. Wang Chong's intervention on the level of staging, however, goes beyond re-assigning actors' lines.

Using multiple sets in the same space, cameras, real-time “editing” (switching between different cameras) and live projection, Wang uses the cinematic technique of cutting between different perspectives to further emphasize the existence of multiple possible ways of telling his characters’ story. For example, in the second scene of the show, we find the male character and “Fanyi” alone in his living room after the party. One camera films them as they sit down on a sofa, stage left, with a bottle of wine and two glasses on a coffee table in front of them. [Figure 34] The onscreen projection cuts to a close-up of the wine and glasses, filmed by a second camera stage left, as the male character fondles the wine bottle in sexually suggestive way. [Figure 35] At this moment, our attention may be drawn to another actor downstage right, who has his own bottle of wine and glasses, and begins to mirror the main actor’s actions. The onscreen image cuts again, this time to a close bird’s eye view of the coffee table and the wine being poured into the two glasses. [Figure 36] With the two actors and multiple cameras in view, it is clear that the shot comes from a camera on a tripod above the second coffee table and the body double, not the space stage left in which the male character and “Fanyi” are playing their scene. A cut back to this scene and the vantage point of the first camera then depicts the male character picking up two glasses of wine and giving one to his companion. [Figure 37]

The chaos onstage contrasts with the film onscreen, which is “edited” in real time by switching back-and-forth between live camera feeds and often relies on the cinematic technique of cutting with a match on action to create the illusion of continuity onscreen despite the different sources. The audience simultaneously views the actor playing Zhou Ping and his body double onstage, being filmed at the same time by different cameras, and enjoys smooth visual bridges between the shots onscreen. On- and off-screen continuity of action are therefore mutually disrupted, and a tension arises between the projected media and its live source. In one



Figure 34 *Thunderstorm 2.0* by Théâtre du Rêve Expérimental, July 2012 (Source: screenshot from performance recording, courtesy Wang Chong and Théâtre du Rêve Expérimental)



Figure 35 *Thunderstorm 2.0* by Théâtre du Rêve Expérimental, July 2012 (Source: screenshot from performance recording, courtesy Wang Chong and Théâtre du Rêve Expérimental)

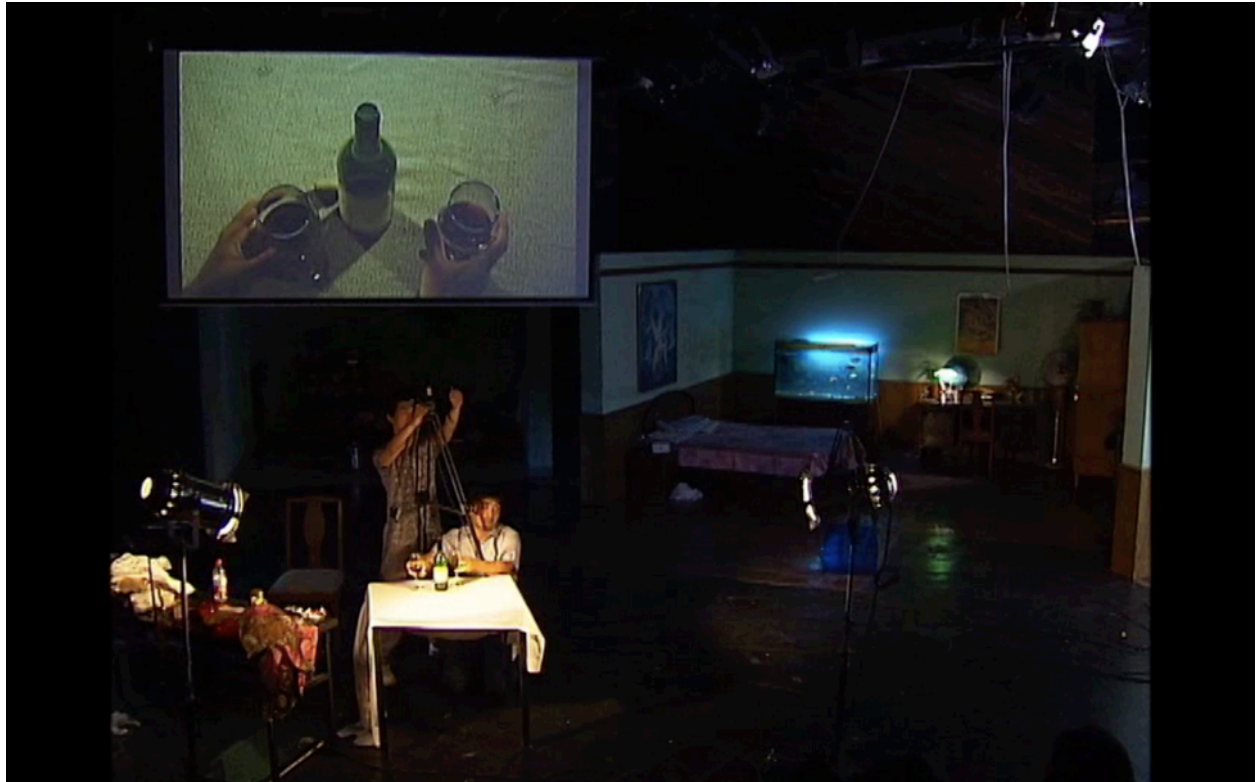

Figure 36 *Thunderstorm 2.0* by Théâtre du Rêve Expérimental, July 2012 (Source: screenshot from performance recording, courtesy Wang Chong and Théâtre du Rêve Expérimental)

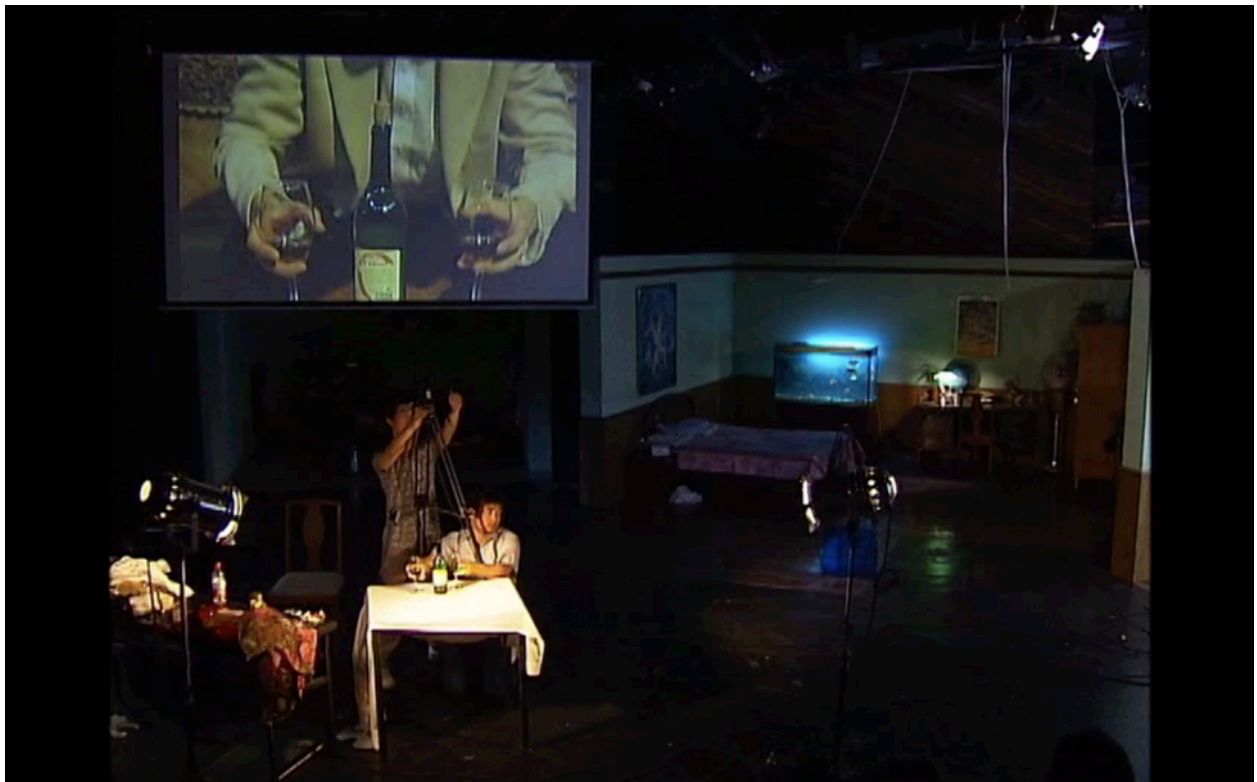

Figure 37 *Thunderstorm 2.0* by Théâtre du Rêve Expérimental, July 2012 (Source: screenshot from performance recording, courtesy Wang Chong and Théâtre du Rêve Expérimental)

critic's appraisal, the theatricality of live filming helps to reveal the hidden constructedness of recorded media—"to dispel the discursive power to construct reality that media in the 'Weibo era' hold (*xiaojie weibo shidai meiti dui zhenxiang jiangou de huayuquan* 消解微博時代媒體最真相建構的話語權)."⁵⁴ The critique in *Thunderstorm 2.0*, however, actually works in a much more specific way, targeting the precise form of constructedness that occurs in the production history of *Thunderstorm*. As Rosemary Klich argues in a study of the use of multimedia to double actors' bodies onstage, "...the double disrupts the notion of a singular undivided self. It therefore problematizes the basic conception of character as a single, consistently defined entity that is still such a feature of some forms of theatre and film."⁵⁵ In the case of *Thunderstorm*, the notions of "character as a single, consistently defined entity" extend beyond the character as written to include the character as consistently performed for decades on the BPAT stage. The disruption of continuity therefore may be read as both a general challenge to the constructedness of theater and media, and as a specific attack on forced attempts to maintain aesthetic and interpretive consistency of the *Thunderstorm* performance text.

In the broader context of large-scale multimedia performance as mainstream with which this chapter began, we may also read this critique as pushing back against the seamlessness and reproducibility often present in technology enhanced productions. At the same time, the contrast between chaos and careful editing onstage takes us back to the issue of the aesthetic of technological excess in those productions. After all, in *Thunderstorm 2.0*, the audience confronts a stage space supersaturated with actors, objects, and images. Aside from the actors playing the three main characters, all other performers have multiple roles as extras, camera operators, and

⁵⁴ Hu Xiang 胡祥, "Yong dianying de fangshi pai yi bu xiju 用電影的方式拍一部戲劇," *Beijing qingnian bao* 《北京青年報》, July 17, 2012, <http://hanenaka.wixsite.com/theatre-du-reve/20120717>.

⁵⁵ Rosemary Klich and Edward Scheer, *Multimedia Performance* (New York: Palgrave Macmillan, 2012), 99.



Figure 38 Publicity photo from *Thunderstorm 2.0* by Théâtre du Rêve Expérimental, July 2012 (Source: Photo by Liu Chen, courtesy Wang Chong and Théâtre du Rêve Expérimental)

stagehands, and they are often all onstage at once. The stage features three different box sets, fully decorated as a living room and two bedrooms, and there are no breaks in the live film playing on the large projection screen hanging above the set stage. [Figure 38] Cords, cameras,

and lighting equipments litter the playing space. On top of this, voice-over narration, foley sound effects, and live instrumental music adds an aural dimension, resulting in a complete sensory overload. Here, despite the vast differences in scale and artistic ethos, the surfeit of sensory data supplied by both live and mediated elements of the performance seems not dissimilar from the way in which technological excess overwhelms audience members in large-scale performances like the Olympics Opening Ceremony or Impressions Series.

This raises the question: in what ways, if any, does this supersaturation of the stage differ from all-encompassing aural and visual effects in a large-scale spectacle? Analyzing a similar use of mechanical noise in *e-Station*, Mari Boyd has written that sounds overlaying the performance “provide the audience with distracting sensory data so that the dearth of language is less noticeable.”⁵⁶ However, as I have argued above, Wang Chong quite self-consciously manipulates dialogue and text in his later work, and, in *Thunderstorm 2.0* at least, the missing lines are as significant as the ones retained. Masking the loss of language would seem counter to his goal of subverting the dramatic tradition. Rather, the answer to this question may lie in the idea of chaos itself. In one post-performance Q&A session, which was later published in the *Xin Jing Bao*, a rather disgruntled audience member responds to this chaos with his question to the director: “The stage looks like a film studio, with workers running around, live filming images appear on the screen, while watching I found it hard to focus my attention, didn’t know where to look, so I couldn’t get immersed in the play. Where do you want the audience to look?”⁵⁷ It is a question that Wang Chong received frequently during the run of the play, both in talkback

⁵⁶ Mari Boyd, “From Ota Shogo’s ‘Earth Station’ to Wang Chong’s ‘e-Station,’” *TheatreForum - International Theatre Journal*, 2009, 71.

⁵⁷ “Jiu cheng guanzhong renke chuangxinban *Leiyu* 九成觀眾認可創新版《雷雨》,” *Xin Jing Bao* 《新京報》, July 23, 2012.

sessions and from journalists, as several articles on the piece quote him on this point. In this particular instance, he replied that: “All of the busyness onstage is part of the content that I’m providing for the audience. This technique reflects our contemporary life—the 2.0 era is an information age. When I’ve seen plays in the past, like you said there’s been a ‘feeling of immersion,’ but *Thunderstorm 2.0* wants to destroy that kind of ‘immersive’ expression.”⁵⁸ This immersion may refer to the narrative and affective engagement of realist theater, in which the spectator becomes absorbed by the world of the play, but it may also refer, as I have argued, to the sensory immersion common in large-scale multimedia performances or even, as Wang intimate, the extent to which daily life has become immersed in technology. Another reviewer quotes Wang Chong in a slightly more eloquent formulation: “Where they should look absolutely has no standard answer, the audience members themselves can each take what they need, this is also one of the meanings of this play— liberation.”⁵⁹ Paradoxically, the supersaturation of *Thunderstorm 2.0* creates freedom through what seems to be distraction. The stage mirrors the state in which Chinese people—especially young urbanites—live their lives: smartphones in hand, Weixin messages flying, enormous screens dotting their peripheral visions as they walk past the Workers’ Stadium or through subway passages in Beijing. The hope seems to be that by placing audiences into a state of theatricalized distraction will encourage them to more consciously exert agency over the surfeit of sensory data that immerse them. In this sense, the segmentation of stage elements mirrors Wang Chong’s approach to script composition; it democratizes the stage space and champions individual interpretation over passive response.

⁵⁸ Ibid.

⁵⁹ The word that Wang uses is *kaifang*, which may also be translated as “opening up.” Du Jinhua 杜晋華, “Huaju? Dianying? Geming? 話劇? 電影? 革命?” *Jingpin gouwu zhinan* 《精品購物指南》, July 19, 2012, <http://hanenaka.wix.com/theatre-du-reve#!20120719/coz3>.

It is in this absorption of a twin logic of distraction and interaction that *Thunderstorm 2.0* can be seen as remediating not theater or film as distinct mediums, but audience experience. Remediation, as articulated by Jay David Bolter and Richard Grusin in their seminal text of the same name, theorizes the relationship between older and newer media, and in its simplest form involves the absorption of an older media into the newer.⁶⁰ There is fundamentally a question of ontology; in Wang Chong's work, however, the staging of film inverts the older-newer relationship, and the question of whether it is theater or film—or cinematic theater or theatricalized film—seems less important than the potentials created by a new logic of reception. It is on this point, perhaps, that his work also distinguishes itself from similar multimedia and intermedial experiments in other smaller-scale contemporary Chinese theater. In a recent book chapter on Meng Jinghui's *Jinghua shuiyue* 《鏡花水月》 (Flowers in the Mirror, Moon on the Water, 2006), for instance, Rossella Ferrari argues for that piece not only as illustrative of a turn towards intermediality in the Chinese theater world that “foregrounds a fundamental ontological tension between a theatre of concept (or existential investigation and aesthetic research) and a theatre of attractions (of technological virtuosity and multimedia spectacle).”⁶¹ In contrast, we may even go so far as to claim that Wang Chong's aesthetic is ultimately concerned with bringing a new media *epistemology* to the theater—a way of discerning what we know about the work of art, and by extension the world beyond, through a process of filtering through a constant stream of input, a state of distraction.

⁶⁰ J. David Bolter and Richard A. Grusin, *Remediation: Understanding New Media* (Cambridge, MA: MIT Press, 1999).

⁶¹ Rossella Ferrari, “Performing Poetry on the Intermedial Stage: Flowers in the Mirror, Moon on the Water and Beijing Avant-Garde Theatre in the New Millennium,” in *Staging China: New Theatres in the Twenty-First Century*, ed. Ruru Li, Chinese Literature and Culture in the World (New York: Palgrave Macmillan, 2016), 125.

Wang's later pieces, *Yijing yisheng yibusheng* 《一鏡一生易卜生》 (*Ibsen in One Take*, 2012) by Norwegian playwright Oda Fiskum, who was based in Beijing at the time of her collaboration with Wang Chong, and *Qungui 2.0* 《群鬼 2.0》 (*Ghosts 2.0*, 2014) extend the critique of modern media and society begun earlier works and can be seen to continue his subversion of Chinese theatrical traditions. Ibsen, along with Eugene O'Neill, Bernard Shaw, and others, figured as a significant source of inspiration and model for the young drama reformers of the 1920s-1930s who christened the new genre. His *A Doll's House*, for example, created waves among readers of *New Youth* 《新青年》 and prompted Lu Xun 魯迅 (1881-1936) to give his famous lecture on what happens after Nora leaves.⁶² It could therefore be argued that Ibsen, like Cao Yu, was one of the founding fathers of Chinese modern drama.

Ibsen in One Take is not a biography of Henrik Ibsen, as the title might seem to suggest, but rather the life story of a melancholy Chinese man comprised of plot points and dialogue fragments from different Ibsen plays.⁶³ Following in the vein of *Reduced Shakespeare*, but with decidedly less comedic intent, Ibsen's entire oeuvre is collapsed into 50 minutes of sound bites and central themes of loneliness and alienation. The "one take" uses cinematic vocabulary to refer both to the metaphorical single shot of the playwright's entire oeuvre and to the use of a single, continuous live feed onstage. Whereas the innovation in *Thunderstorm 2.0* largely lies in its staging of film editing, *Ibsen in One Take* makes a single camera into an actor in the play. However, the effect is similar; just as the smoothly edited film onscreen in *Thunderstorm 2.0*

⁶² The essay was originally delivered as a talk at Beijing Women's Normal College in December 1923. Lu Xun 魯迅, "Nala zouhou zeyang? 娜啦走後怎樣?," in *Lu Xun quanji* 《魯迅全集》, vol. 1 (Beijing: Renmin wenxue chubanshe, 2005), 160; Hua R. Lan and Vanessa L. Fong, *Women in Republican China: A Sourcebook* (Armonk, NY: M.E. Sharpe, 1999), 176-181.

⁶³ All descriptions of *Ibsen in One Take* that follow are based on a recording of the production at the Shanghai Dramatic Arts Center, November 2013, and *Ghosts 2.0* based on footage from 2014. My thanks to Wang Chong and Théâtre du Rêve Expérimental for providing me with the recording.

creates a tension with the chaos onstage, so too does the continuous take onscreen contrast with the trajectory of the action in *Ibsen in One Take*, which does not follow a linear narrative. It begins at the end of the protagonist's life, with him laying in a hospital bed, and proceeds to jump back and forth between past and present, youth and old age, dream and reality. Audience members may recognize quotations from Ibsen's most famous scenes, such as the one from *A Doll's House* in which Nora leaves her husband, but citations of Ibsen's lesser-known works are nearly indistinguishable from new text added by Fiskum.

In effectively using a single camera/cameraman as an actor in *Ibsen in One Take*, Wang Chong again delves into the relationship between liveness and mediation onstage. By filming a fictional biopic live, in real time in *Ibsen in One Take*, Wang suggests the constructedness of both the canon of Great Books and the cinematic medium. He also points to an inherent liveness in the cinematic technique of the long take; by choreographing and staging a single camera to follow actors for 50 minutes, uninterrupted, he calls audience attention to how contingent film actually can be. Moreover, throughout the play, the camera operator remains silent and in all black, but it is his camera's point of view that dominates the simply furnished stage as it projects close-ups on the large screen hanging above the playing space. [Figures 39, 40]⁶⁴ This omnipresent outside perspective can be read as an awareness of the ways in which anyone's life story is perceived and projected by forces external to oneself. As Wang has noted to the press, in this piece, "Live media on stage reflects our media-filled lives, and how we constantly perform

⁶⁴ Production photos from the Beijing premiere show a more complex set and slightly smaller screen than the touring production. See Figure 40. Wang Chong confirmed that certain set elements were cut after the premiere and for their tour, for both practical and aesthetic reasons. Interview with Wang Chong, January 15, 2015; personal communication, August 28, 2016.



Figure 39 *Ibsen in One Take* by Théâtre du Rêve Expérimental, November 2013 (Source: Screenshot from performance recording, courtesy Wang Chong and Théâtre du Rêve Expérimental)

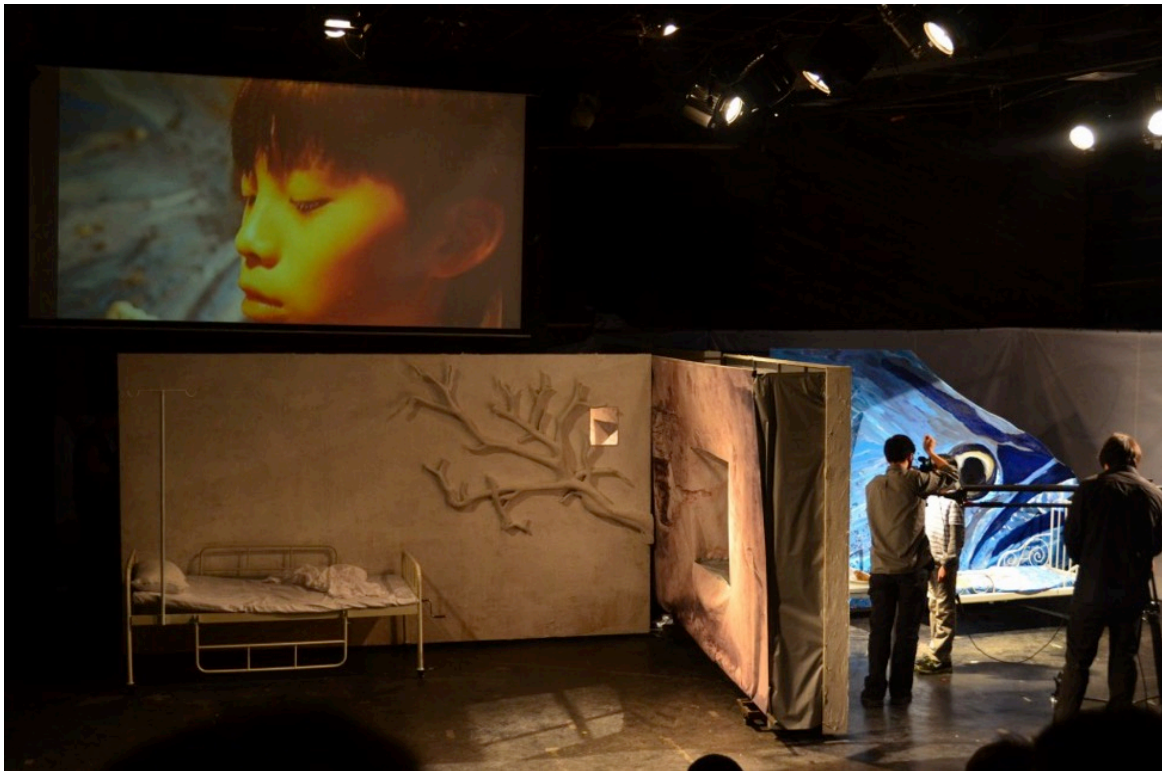

Figure 40 Production photo from *Ibsen in One Take* by Théâtre du Rêve Expérimental (Beijing, 2012) (Source: <http://ibseninternational.com/productions/ibsen-in-one-take/>, courtesy Wang Chong and Théâtre du Rêve Expérimental)

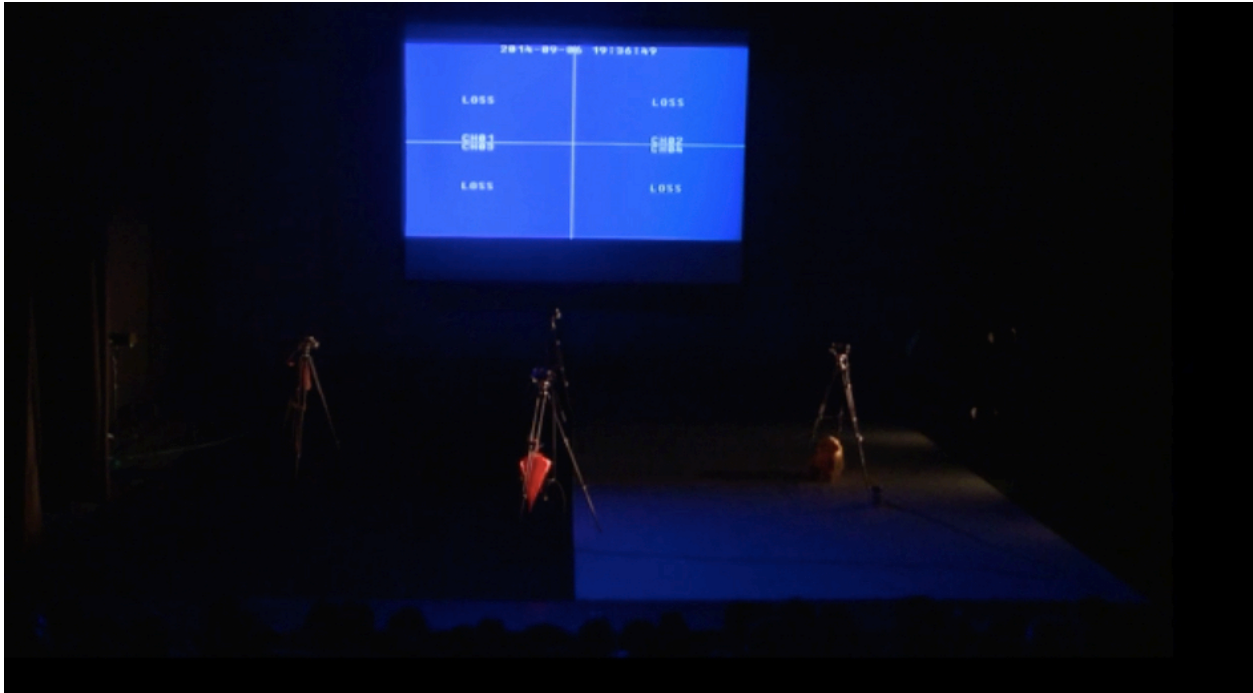

Figure 41 *Ghosts 2.0* by Théâtre du Rêve Expérimental, 2014 (Source: Screenshot from performance recording, courtesy Wang Chong and Théâtre du Rêve Expérimental)

for and are watched by lenses that are everywhere.”⁶⁵ By seeing this process enacted onstage, audiences can become more aware of their own situation, and begin to question the lines between “real” and “fake” in everyday life.

This idea of media as a tool of surveillance connects the camerawork in *Ibsen in One Take* to Wang Chong’s next piece, *Ghosts 2.0*, which uses the same kind of equipment that is used for surveillance and nods to more insidious controls of image and media. As the title signals, this *Ghosts* returns to basic conceit of *Thunderstorm 2.0*: deconstruction of a modern classic through the intervention of new technologies. In *Ghosts 2.0*, however, we can see Wang Chong integrating lessons learned from both *Thunderstorm 2.0* and *Ibsen in One Take*. The original text is again truncated and fragmented, but in this case retains more of its original narrative arc than

⁶⁵ Liao Danlin, “New ‘Take’ on Ibsen,” *Global Times*, October 9, 2013, <http://www.globaltimes.cn/content/816612.shtml>.

in *Thunderstorm 2.0*. Likewise, we return to multiple cameras onstage, but the use of a closed-circuit television switcher implies the existence of several continuous, unbroken feeds—like the feed in *Ibsen in One Take*—even when only one or two are displayed. [Figure 41]

The use of surveillance equipment in *Ghosts 2.0* materializes and modernizes the themes of public scrutiny of private acts that underlies Ibsen's original. In *Ghosts*, reputation and shame are motivating factors; the entire plot revolves around the construction of an orphanage in memory of Captain Alving, which his wife hopes will serve to preserve his honorable image in the eyes of the community and permanently mask the scandals of their private life of infidelity and unhappiness.⁶⁶ Wang Chong's adaptation retains this central narrative, as well as the plot points involving Mrs. Alving's son, who has congenital syphilis thanks to his father's dalliances and also unknowingly falls in love with his half-sister by another mother.⁶⁷ Wang's ghosts, however, take a different form from Ibsen's; rather than the *revenant* manifest in hereditary disease and personality traits, these specters are the mediated doubles of onstage live actors. In the contemporary world of versions 2.0 and 3.0, these ghosts may be read as a comment on the way in which past interpretations of famous characters haunt contemporary actors, as with *Thunderstorm*, or perhaps on the way in which our lives are always already followed as we constantly both submit ourselves to security surveillance and record everyday moments for posterity on social media platforms. As in the doubling of the actors and their images onstage in *Ghosts 2.0*, our mediated selves now haunt us long before we have left this world.

Both *Ibsen in One Take* and *Ghosts 2.0* also raise the specter of who it is that manipulates

⁶⁶ Henrik Ibsen, "Ghosts," in *Henrik Ibsen: Four Major Plays*, trans. James McFarlane and Jens Arup (Oxford, UK: Oxford University Press, 2008), 89–164.

⁶⁷ This plot point in particular resonates with the incestuous relationships in Cao Yu's *Thunderstorm*, but Wang Chong chooses to deemphasize this particular theme in both adaptations.



Figure 42 *Ghosts 2.0* by Théâtre du Rêve Expérimental, 2014 (Source: Screenshot from performance recording, courtesy Wang Chong and Théâtre du Rêve Expérimental)

technology, onstage and otherwise. Discussing the use of the closed-circuit television equipment in *Ghosts 2.0*, Wang notes that he and his production team did not set out trying to make a point about government censorship, and that he chose to use the surveillance feed as a way to visually reference mediated communications, like Skype, and the multi-screen aesthetic of videos on sites like Youtube.⁶⁸ Yet, intentional or not, Wang’s use of this equipment cannot but call to mind the PRC government’s constant monitoring of its citizens and, within theater and performance, the fact that the state is typically behind the scenes in the productions that have access to high-tech equipment.⁶⁹ However, the fact that the cameras have human operators also introduces the

⁶⁸ Interview with Wang Chong, January 15, 2015; personal communication, August 28, 2016.

⁶⁹ A similar observation about government surveillance is made in a review of performances *Ghosts 2.0* in Tokyo (November 2014). Iwaki Kyoko 岩城京子, “(評舞台) 薪伝実験劇団「ゴースト2.0」 現代中国を覆う「嘘くささ」,” *Asahi Shinbun* 《朝日新聞》 (November 27, 2014), <http://hanenaka.wixsite.com/theatre-du-reve/20141127j>.

possibility of another interpretation. In *Ibsen in One Take*, audience members watch as the camera becomes a literal extension of the cameraman, who alternately uses a long boom to insert the apparatus into the scene and holds it in hand. Therefore, it is ultimately not the lens—a purely mechanical apparatus—that exerts agency over the images onscreen, but rather the human behind the lens (and the director behind him). In *Ghosts 2.0*, for the most part, the actors likewise take the four cameras into their own hands, and at times they directly confront the lenses. [Figure 42] They exhibit awareness and control, even as the frame of the surveillance screen suggests otherwise. This humanizes the camera and reveals a continued possibility of human agency working in tandem with technology, even when there is someone else lurking behind the viewfinder.

Intervention and Disruption: Feng Jiangzhou and the Art of Noise

If Wang Chong's status as an artist almost entirely outside the state-sponsored system may in some way enable him to take a relatively clear stance against the reproducibility of theater and hegemonic uses of technology by that system, the situation becomes murkier when the artist's position is more compromised. The second case study in this chapter will examine one such artist: multimedia designer Feng Jiangzhou, who began his career as painter, transformed into a punk rocker, then moved into the theater and multimedia installation through collaborations with the Hong Kong-based theater collective Zuni Icosahedron (Jinnian ershimianti 進念二十面體) and with director Meng Jinghui. Trained at the Zhejiang Academy of Art (Zhejiang meishu xueyuan 浙江美術學院), now the China Academy of Art (Zhongguo meishu xueyuan 中國美術學院), in the 1980s, Feng started a band called Cangying 蒼蠅 (The

Fly) in 1993 that soon became an underground hit.⁷⁰ The band was primarily known for both their unconventional sound, which borrowed from Japanese noise music, and the vulgarity of their lyrics, penned by Feng himself. In particular, as scholarship on The Fly has noted, their focus on raw bodily functions and the “dirt, chaos, and trash” (*zang, luan, cha* 髒亂差) of 1990s China cultivated “a collective rage at current social squalor.”⁷¹ However, while such criticism was in theory politically risky, The Fly managed to keep from running afoul of government censors, and Feng has later claimed that there was never any particularly subversive intent behind his music. As he told one interviewer in 2010, despite the fact that many people interpreted their dirty lyrics as covering up hidden meanings, he never intended for his music to have any particular ideological content.⁷²

Music was also his point of entry into Chinese theater and new media art. In 2001, while still a member of The Fly, he traveled to Hong Kong to participate the “Berlin Electronic Music vs. Beijing Electronic Music” concert hosted by Zuni Icosahedron and to collaborate with Zuni on the music for their theater piece, *Lienü zhuan* 《烈女傳》 (Chronicles of Women: Illness as Metaphor, as translated by the group).⁷³ Through Zuni co-artistic director Mathias Woo (Hu

⁷⁰ Although Feng Jiangzhou is acknowledged as one of the most widely acclaimed underground musicians of the 1990s, little has been written about his work in English-language scholarship. For brief discussions of his punk music and later turn to digital hardcore, see Jeroen de Kloet, *China with a Cut: Globalisation, Urban Youth and Popular Music* (Amsterdam: Amsterdam University Press, 2010); Jeroen de Kloet, “Cosmopatriot Contaminations,” in *Cosmopatriots: On Distant Belongings and Close Encounters*, ed. Edwin Jurriëns (Amsterdam: Rodopi, 2007), 133–54; Hao Huang, “‘Yaogun Yinyue’: Rethinking Mainland Chinese Rock ‘N’ Roll,” *Popular Music* 20, no. 1 (2001): 1–11; Hao Huang, “Voices from Chinese Rock, Past and Present Tense: Social Commentary and Construction of Identity in Yaogun Yinyue, from Tiananmen to the Present,” *Popular Music and Society* 26, no. 2 (2003): 183–202, doi:10.1080/0300776032000095512.

⁷¹ Huang, “Yaogun Yinyue,” 10–11.

⁷² Wang Tianxiang 王天翔, “Feng Jiangzhou: kuajie zhi jie you duoyuan 丰江舟：跨界之界有多遠,” *Youpin* 《優品》, 2010.

⁷³ In total, Feng worked on music for three productions with Zuni: an experimental music concert entitled “Berlin Electronic Music vs. Beijing Electronic Music,” and two performances, *Lienü zhuan* 《烈女傳》 (usually translated

Enwei 胡恩威), Feng was introduced to Meng Jinghui, whose career had just begun to take off.⁷⁴ Meng had in fact been working in the theater for over a decade at this point, but it was not until the late 1990s that Meng's unique avant-garde, postmodern directing style started to gain a popular following.⁷⁵ In 2002, Feng joined Meng and Woo on their production of *Guanyu aiqing guisu de zuixin guannian* 《關於愛情歸宿的最新觀念》 (*Head without Tail*, also translated as *Heads or Tails*); the following year, he did multimedia design for a revival of *Lian'an de xiniu* 《戀愛的犀牛》 (Rhinoceros in Love), a play by Liao Yimei 廖一梅 that remains one of Meng's most popular and most frequently revived works to this day. These productions would lead to an eight-year collaboration among Meng, Feng Jiangzhou, and set designer Zhang Wu 張武, with Feng doing both musical composition and multimedia effects for larger shows such as *Hupo* 《琥珀》 (Amber, 2005) and *Yanyu* 《豔遇》 (An Erotic Encounter, 2007) as well as more experimental productions such as *Ai bi si geng lengku* 《愛比死更冷酷》 (Love is Colder than Death, 2008) alike.⁷⁶ Through these projects, Feng established himself as one of the preeminent multimedia theater artists in China and in 2008, he founded his own workshop, the Sifenlv New Media Studio (Sifenlü xinmeiti gongzuoshi 四分律新媒體工作室).

Given that much of their work, such as *Amber* and *An Erotic Encounter*, was produced by Meng Jinghui's official work unit, the National Theater Company of China (Guojia huajuyuan

as *Biographies of Exemplary Women*, but titled in English by Zuni as *Chronicles of Women: Illness as Metaphor*) and an early production of *Du dang yi mian* 《獨當一面》 (*Solos – Experimenting Chinese Opera*). Zuni *Icosahedron*, accessed September 13, 2015, <http://www.zuni.org.hk/new/zuni/web/default.php?cmd=performance>.

⁷⁴ Lu Shiwei 盧世偉, "Meng Jinghui VS Feng Jiangzhou: women yaode jiushi bu anquan 孟京輝 VS 丰江舟‘我們要的就是不安全,'" *Sohu Entertainment*, March 7, 2007, <http://yule.sohu.com/20070330/n249095375.shtml>.

⁷⁵ Rossella Ferrari discusses in detail the different periods of Meng's career in her monograph and dates the beginning of his "unprecedented popularity" to the late 1990s. Ferrari, *Pop Goes the Avant-Garde*, 86.

⁷⁶ A full list of collaborations can be found on the website for Sifenlv 四分律 (<http://www.sifenlv.com>).

國家話劇院), the collaboration between Feng Jiangzhou and Meng Jinghui seems to fit into the broader trend of a connection between state, technology, and the performing arts demonstrated by large-scale multimedia performance, although these productions were a few years ahead of the official political connection of the three spheres. Feng has told interviewers that having been labeled as “underground” has at times made it difficult for him to work within the established system, but in practice this has not stopped him from collaborating with major directors like Meng and even Zhang Yimou.⁷⁷ He was a member of the team working with Zhang Yimou on the LED scroll segment of the Olympics Opening Ceremony and has also worked on the annual CCTV Spring Festival Gala.⁷⁸ He also did multimedia design for Zhang Yimou’s 2012 production of *Turandot* at Wembley Stadium, in London.⁷⁹ This particular version of *Turandot* was produced by the Beijing Gehua Cultural Development Group, which from its name seems to be a private enterprise; yet, like many such “companies” in China, it is actually state-owned.⁸⁰

⁷⁷ Liang Shuang 梁爽, “Feng Jiangzhou: dianzi meiti de ‘luodi’ shiyan 丰江舟：電子媒體的‘落地’實驗,” *Dongfang yishu* 《東方藝術》 7 (2009): 79–81.

⁷⁸ It is difficult to substantiate Feng Jiangzhou’s involvement in the Olympics. One article refers to him as the designer of the LED scroll in Olympics Opening Ceremony, but he does not widely claim credit for this. Feng’s involvement in the CCTV Gala is more frequently discussed. “Nufang Shanghai Zhan Wutai Sheji Tubaoguang, Chenda Caimu Chengwei Liangdian,” *Tencent Entertainment* (Tengxun Yule 騰訊娛樂), November 10, 2010, <http://ent.qq.com/a/20101110/000020.htm>; “Shenme ye mei dianfu Feng Jiangzhou: wo dui Zhongguo yaogun mei zeren 什麼也沒顛覆丰江舟：我對中國搖滾沒責任,” *Dongfang zaobao* 《東方早報》, n.d. Reprinted online in the Culture section of the *Zhongguo jingji wang* 中國經濟網 (Chinese Economics Network) December 21, 2007 on http://art.ce.cn/yymb/ylysj/200712/21/t20071221_13994439.shtml. Both articles are reprinted on the Sifenlv website: <http://sifenlv.com/article/detail/?lang=c&id=3>; <http://sifenlv.com/article/detail/?lang=c&id=10>.

⁷⁹ The latest and least discussed of Zhang Yimou’s reinventions of *Turandot*, which follows his 1998 production in the Forbidden City, a 2009 production in Beijing’s Bird’s Nest Stadium, and tours to Taiwan and a number of European cities. For more on Zhang Yimou’s engagement with Puccini’s opera, see Sean Metzger, “Ice Queens, Rice Queens, and Intercultural Investments in Zhang Yimou’s *Turandot*,” *Asian Theatre Journal* 20, no. 2 (2003): 209–17; Ken Smith, “A Princess Comes Home,” *Opera* 63, no. 12 (2012): 1473–79.

⁸⁰ Gehua is a typical example of a 21st century Chinese cultural conglomerate—it is a state-owned enterprise, but attempts to operate on a share-holding model and finance itself by its own revenue. See Lily Kong and Justin O’Connor, *Creative Economies, Creative Cities: Asian-European Perspectives* (Dordrecht: Springer Netherlands, 2009). For reference to Gehua’s involvement with *Turandot*, see Zhang Ming’ai, “Zhang Yimou to Stop Filming, Direct Britain’s *Turandot*,” *China.org.cn*, April 1, 2012, http://www.china.org.cn/arts/2012-04/01/content_25043758.htm.

Feng also ventures outside of the theater to exhibit new media art installations in both official shows, hosted by city governments or the Chinese Academy of the arts, and at galleries in venues like Beijing's 798 district. Feng even takes on purely commercial commissions, such as designing lighting for the opening of the Mercedes-Benz flagship store in Beijing in 2011 and partnering with shopping malls to do multimedia-heavy performances in their center concourses.

Feng, it seems, has always been a chameleon, and he uses his engagement with technology and new media as a set of skills that allow him access to different sectors of the professional arts world. For Feng, technology became his entre into a high profile, legitimated career. Yet, he is far from content with the opportunities provided by government-funded and commercial projects. Instead, Feng directly parlays elements of these projects into work at the opposite end of the spectrum: radically experimental multimedia sketches. He prides himself on his personal investment in new media for the sake of new media:

Doing new media is a way of realizing my own potential. It's a combination of many different things and it's simply that some pieces will go in certain directions, but that doesn't mean I want to fully invest myself in that direction. The fact that this piece leans toward theater certainly doesn't mean that I want to break into the theater world. It doesn't mean that I want to be like Meng Jinghui. The kind of theater that I do is new media theater, and I have no desire to become a part of the traditional theater profession.

我覺得我做那個事情都不過癮，我覺得做音樂家不甘心，我很多的才華能量沒發揮，做新媒體是實現自我價值的，它是很多東西的一個集合，無非是你這個作品偏向於哪個方向而已，但並不是我要介入，這作品是偏向戲劇的並不是我要進入戲劇界，不是說我要等同於孟京輝，我做的戲劇是新媒體戲劇，我不願意去介入傳統的戲劇行業這個門類。⁸¹

In this vein, his Sifenlv New Media Studio regularly develops and produces new works of what

⁸¹ Feng Jiangzhou 丰江舟, Feng Jiangzhou: shuzi yishu gai zenme wan 丰江舟：數字藝術該怎麼玩, interview by Wang Boqiao 王泊喬, April 2, 2009, <http://blog.artintern.net/article/38298>.

Feng terms “independent multimedia theater” (*duli duomeiti ju* 獨立多媒體劇).⁸² While even these independent works often rely on Feng’s institutional connections for their exhibition opportunities, they diverge from his other work in that they are more purely devoted to artistic and technological experimentation.⁸³ Feng and his team will spend months developing boutique applications of new technologies and working with performers, only to then have productions play for only a single performance (or a single weekend), sometimes without ticketed admissions.

We can trace Feng’s engagement with the relationship between visual and aural perception through several projects with different profiles: a multimedia art installation designed for a public art project in Shanghai’s Zhangjiang Hi-Tech Park in 2007; his first independent multimedia theater piece, *Chun chui feng* 《春吹風》 (Spring Wind) that same year; and his collaboration with Meng Jinghui and designer Zhang Wu on a production of *Love is Colder than Death* in 2008. The first of these, a public art piece for the Shanghai development area that aspires to be China’s Silicon Valley, was entitled “2007 Xianchang Zhangjiang: Shiyi de tingliu” 2007 現場張江：詩意的停流 (2007 Live Zhangjiang: Poetic Stop/Flow) and was the second in a series sponsored by the Tech Park, with the support of the local government and the goal of adding to the Park’s real estate value and ability to attract creative talent to tech industries.⁸⁴

Feng contributed to the exhibit’s opening performance and created “Bayin 八音” (Eight Sounds),

⁸² In published interviews, Feng has said that he prefers the term “transmedia” (*kuameiti* 跨媒介) to “multimedia” (*duomeiti* 多媒體) and has also sometimes advertised productions as “digital theater performance” (*shuzi wutai biaoyan* 數字舞台表演). However, on the Sifenlv website, he uses the category “multimedia theater” (*duomeiti ju* 多媒體劇). For the sake of consistency, I will follow that convention in this chapter. Liang Shuang, “Feng Jiangzhou: sianzi meiti de ‘luodi’ shiyan.”

⁸³ For instance, the Sifenlv website credits figures in the Ministry of Culture and faculty at institutions like the Chinese Academy of Fine Arts as “curators” (*cezhanren* 策展人) for a number of these productions. See <http://sifenlv.com/about/detail/?id=1>.

⁸⁴ Laikwan Pang, *Creativity and Its Discontents: China’s Creative Industries and Intellectual Property Rights Offenses* (Durham, NC: Duke University Press, 2012), 137–138.

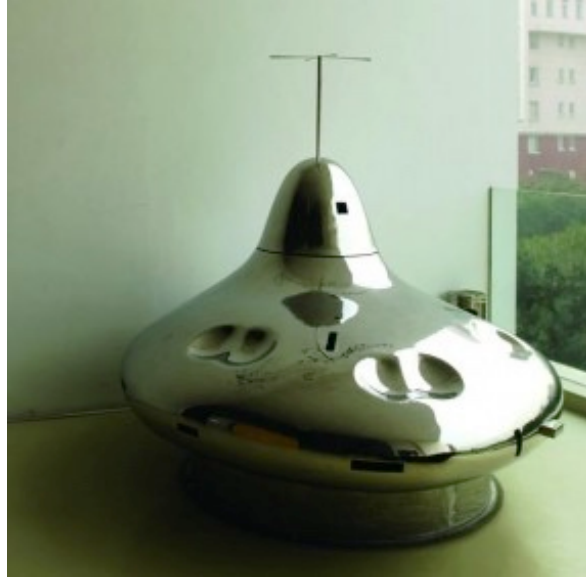

Figure 43 Bayin 八音 (Eight Sounds, 2007)
(Source: Sifenlv New Media Studio website
<http://www.sifenlv.com/>)

a metal sculpture that resembles a silver amoeba with a television antenna sprouting from it. [Figure 43] Designed to be interactive, the silver amoeba had three spots for viewers to sit on it and emitted different electronic sounds (also created by Feng) based on the number of people sitting and how they moved.⁸⁵ Although not a work of theater per se, the piece did create an interactive experience that played with the relationship between audience and artwork, as well as the relationship between the aural and the visual perception of that work.

That same year and in the nearby city of Hangzhou, Feng presented his first independent multimedia theater piece, *Chun chui feng* 《春吹風》 (Spring Wind), at his alma mater, the Chinese Academy of Art. In the short performance, a powerful projector throws moving images of bare bodies doing calisthenics and scenes from the Cultural Revolution-era model opera film,

⁸⁵ “Shenme ye mei dianfu Feng Jiangzhou: wo dui Zhongguo yaogun mei zeren.”

Zhiqu weihu shan 《智取威虎山》 (Taking Tiger Mountain by Strategy) onto a large screen.⁸⁶

Frequent cuts back-and-forth between the two sets of footage draw out the similarities in their underlying fascist aesthetics and corresponding histories of attempts to discipline the human body. These black-and-white images dwarf both the performance's DJ, suspended in a cage slowing descending along the way, and the three actors, clad in all black, who begin to rappel down the screen mid-way through the performance. Intermittently, jarring visual noise—reminiscent of the static created by bad television antennae signals or faulty VHS videocassettes—interrupts the parade of images on the larger-than-life screen and disrupted the uneasy parallel drawn between them. The ant-like actors and the projected “snow” punctuate the performance with two distinct kinds of interference: the stealthy movement of a single, nearly invisible individual through the bigger picture and the sudden cessation of a signal due to the intervention of a higher power or a technical glitch.

These two pieces, one public art installation and one multimedia performance, share the concept of introducing electronic music into the contexts of art exhibition and theatrical performance. In doing so, they establish one of the fundamental principles of Feng's multimedia work, what we might think of as an aesthetics of noise. This aesthetics of noise operates on multiple levels; at its most basic, it involves Feng bringing his background in noise music and talent as a musician to bear on the theater and visual arts. Even though the theater is commonly acknowledged in China to be a composite art form, it is often the visual that is privileged in discussions of non-operatic (non-*xiqu*) forms, especially those that use multimedia effects onstage. For instance, Rossella Ferrari has argued of Feng that “his work and vision have impacted substantially on the visual makeover of China's contemporary stage and, consequently,

⁸⁶ Descriptions of these productions based on a DVD sampler of recordings of Feng's work. My thanks to Feng and Sifenlv New Media Studio for providing me with the VDV.

on its media and market appeal.”⁸⁷ This is true, but it ignores the fact that Feng’s work is rarely limited to purely visual applications of media and technology. In fact, his impact goes beyond the visual; his work is actually all about combining the visual, aural, and physiological, and manipulating these senses through technology. On another level, Feng’s aesthetics is about noise as interruption and disruption. In *Eight Sounds*, an oddly shaped object and unintelligible “noise” disrupt preconceptions about the relationships among audience, art, and public space. In *Spring Wind*, the music mixed live by the DJ confounds expectations of the kind of sound that ought to accompany footage from opera films, while visual noise—literal television static—interferes with smooth sutures suggested by juxtaposed projections.

Feng’s aesthetics of noise is again central in his collaboration with Meng Jinghui and designer Zhang Wu on *Love is Colder than Death* at Meng’s Fengchao juchang 蜂巢劇場 (Beehive Theater) the following year. Based on Rainer Werner Fassbinder’s 1969 debut film of the same name, the play mimicked both the style of the German New Wave and the experience of watching dubbed foreign films. The stark, nearly colorless set quite literally transferred the black-and-white film aesthetic onto the stage, while a 45-degree sloping ceiling and solid side walls hid the obvious visual cues of a “theater”—curtains, hanging lighting units, glimpses of backstage—from view. Designers and director added to the closed-in, claustrophobic feeling of the playing space and created a visceral separation between audience and actors by placing a Plexiglas wall between them. Each audience member was then provided with a set of headphones through which they could hear the lines spoken onstage. One review of the production describes the experience as follows:

The audience uses headphones to receive the sounds, and in addition to simply hearing

⁸⁷ Ferrari, *Pop Goes the Avant-Garde*, 88–89.

dialogue, there is also detailed descriptions, such as ‘In jail, Cindy and four others face the audience. Franz stands with his back to the audience...’, as well as all manner of live sounds—gunshots, the creaking of chairs and tables, the rustling of skirts, footsteps, etc.—all amplified through the headsets, with intentionally manufactured noise intermingling throughout.

觀眾們借助耳機接受聲音，除了聽到簡單的對白，還有詳細的解說：‘監獄內，辛迪加四個人面對觀眾。弗蘭茨背對著觀眾...’槍聲，桌椅的吱呀聲，裙擺沙沙聲，腳步聲等現場聲都在耳機中被放大，還夾雜著故意製造出的噪音。⁸⁸

At times, a lag in the transmission of the onstage sounds further separated the action onstage (specifically, the movement of the actors’ mouths) from the audience’s perception of that action. This distancing simultaneously calls to mind the Brechtian concept of estrangement and invokes the split between the aural and the visual felt when watching dubbed films—a feeling that would have been familiar to Chinese fans of foreign films. That is to say, on one level the effect is a specifically aural one, meant to call attention to the bizarre disconnection of sound from image and the technologies that mediate that relationship. Therefore, while this production was certainly a collaborative effort by Meng Jinghui, Feng Jiangzhou, and Zhang Wu, we can see some of Feng’s specific artistic concerns driving the application of technology in the production. More specifically, the dubbing-like lag time and the use of “*zaoyin* 噪音” (literally, noise) to interfere with the audience experience of the staged film seem to build on his earlier experiments with visual/aural interference and manipulating audience engagement in *Spring Wind* and *Eight Sounds*.

As with Wang Chong’s chaotic stage in *Thunderstorm 2.0*, we might think of the multi-sensory experience created by Feng’s work as related to the aesthetic of technological excess present in large-scale multimedia spectacles. Again, audience members are confronted with

⁸⁸ “*Ai bi si geng lengku ge boli erji xinjian xiju* 《愛比死更冷酷》隔玻璃帶耳機新鮮戲劇,” *Sina Film Music and Entertainment*, November 8, 2008, <http://ent.sina.com.cn/j/p/2008-11-08/00432241268.shtml>.

multi-sensory experiences that threaten to immerse and overwhelm them; in this case, the artist himself supplies clear and jarring interference in the form of visual and aural noise that disrupts that potential immersion. In addition, the use of spectator-controlled sound in *Eight Sounds* and headphones in *Love is Colder than Death*, in particular, resonate with the use of headphones in Zhang Yimou's *Impression West Lake*. The interactivity of the former works against more manipulative applications of sound, and the obvious disjunction between sound and image in the later creates a suspicion of the supposed truths transmitted by technologies—or theaters—of reproduction. Far from using headphones to reinforce audience members as neoliberal subjects, as Audrey Yue has worried in relation to *Impression West Lake*, Feng Jiangzhou and Meng Jinghui's individuation of audience in *Love is Colder than Death* compelled spectators to confront the troubling reality of their roles as spectators of television, film, theater, and performance.

A similar aesthetic and ethos underlies the works of independent multimedia theater that Feng and his team at Sifenlv have produced since the studio's founding in 2008. For example, in *Jiaxiang xilie* 假象系列 (Reading-Mistake Series, as translated by Feng), Feng and his collaborator Zhang Lin 張琳 (b. 1982) conduct increasingly high-tech experiments over the course of three pieces produced in 2009-2010.⁸⁹ The translation of the title as “Reading-Mistake” is in fact not literal; the compound *jiaxiang* could be rendered more accurately as “semblance” or “appearance,” with the added caveat that *jia* on its own often indicates falsity or pretense. With this terminology, Feng and Zhang may be gesturing in the direction of Buddhist concepts of the

⁸⁹ Since 2010, much of Feng Jiangzhou's work has developed in collaboration with Zhang Lin, his partner in the Sifenlv New Media Studio and wife. Zhang was educated at the Central Academy of Fine Arts (Zhongyang meishu xueyuan 中央美術學院) and the Rhode Island School of Design, where she completed an MFA in Digital Media in 2010. Her curriculum vitae and work through 2012 can be viewed at her personal website: <http://www.zhanglinmedia.com/>.

falsity of all appearances, i.e. all impressions, and reality as an illusion. Such a reading is supported by the fact that the title of his studio, Sifenlv, is itself a Buddhist reference to the “Four Part Vinaya,” a text with codes for monastic life transmitted to China in the 5th century. Simultaneously, the title makes a more direct jab at Zhang Yimou’s Impressions Series: three of the four characters in the two series’ titles are the same, with the exception of the first in each: *yin* 印—stamp, print, mark—is replaced with *jia* 假—fake, false, artificial.⁹⁰ This double meaning highlights the vast distance between Buddhist awareness of illusion and the Impressions Series’ exploitation of the same. And indeed, one of the main themes running through these three pieces seems to be the problem of misperception. In the second and third pieces, *Jiaxiang xilie er* 《假象系列二》 (Reading-Mistake Series 2) and *Jiaxiang xilie er* 《假象系列三》 (Reading-Mistake Series 3), for instance, Feng plays with the relationship between real bodies and flickering, ghostly projected bodies onstage. At times, it is difficult to discern which are his actors and which are his projections, and the actors themselves *become* projections as their all-white costumes function transform into screens for moving lights and images. The fact that these pieces involve no dialogue, only movement, on the part of the actors makes it even more difficult to differentiate between live and mediated bodies. However, where the Impressions Series aims for a harmonizing of actors’ bodies with technological spectacle and an absorption of the audience into the same—akin to the transparent immediacy discussed by Bolter and Grusin—Feng’s productions call attention to the too-easy slippage between the two and push the audience to critically engage in the process of differentiating between them.⁹¹ Visual noise also reappears

⁹⁰ As noted above, Zhang Yimou began to work on pieces in his Impressions Series in 2004. By 2006, there are references to the “Impressions Series” in news media, and from a cursory search of newspaper databases, the term seems to have been widely used by the time the fourth production *Impression Hainan Island* premiered in 2009.

⁹¹ Bolter and Grusin, *Remediation*, 20–35.

in all three productions, in the form of large-scale projection of static and pixelated patterns, to interrupt any illusion of smooth exterior.

The fact that Feng regularly collaborates with pop director Meng Jinghui and godfather of large-scale multimedia performance Zhang Yimou, of course, may complicate this seeming critique. In fact, he was just beginning to collaborate with Zhang at precisely the time he was producing his Reading-Mistake Series. However, in Feng's multimedia design for large-scale spectacles, we can see some hint that he carries his critical edge even into these designs. For instance, one of Feng's most recent projects was the multimedia design for the latest production in the Impressions Series, *You jian Wutaishan* 《又見五台山》 (Encore Mount Wutai).

Premiered on September 19, 2014, *Encore Mount Wutai* was directed by Wang Chaoge and takes place in a specially constructed theater on the Buddhist site of Mount Wutai in Shanxi province, which spectators reach via a 730-meter-long outdoor installation functioning as a prelude to the performance proper. When viewed from above, the glass and concrete walls of the installation mirror the shape of an unfolding volume of sutras and are meant to lead spectators to contemplate the relationship of self, space, and emotion.⁹² This state of contemplation carries spectators indoors, where they pass through a number of small rooms before reaching the cavernous revolving performance space and spectacular rendition of one man's journey through life (with appropriately Buddhist themes).

As if the marriage of spectacle and Buddhist themes were not already at odds, Feng's multimedia design of the production creates further tension by juxtaposing ancient practices with a decidedly high-tech aesthetic. In one scene, for instance, seven actresses, dressed in

⁹² Wang Chaoge 王潮歌, "Guanyu women 關於我們," *Encore Mount Wutai*, accessed April 14, 2016, <http://www.yjwts.com/index.php?m=content&c=index&a=lists&catid=26>.

characteristic *xiqu* costumes with long white *shuixiu* 水袖 (water sleeves), pose against a temple gate as a large-scale projection of water and a Buddha's face hover over them. The lighting and the projection fade into concentric circles of spinning white characters, each of which is nearly the size of the human figures onstage. With an empty black space at their center, the spinning circles of characters resemble the iris of an eye, or perhaps a black hole.⁹³ [Figure 44] As the scene onstage shifts to a group of monks meditating and illuminated with red light, the projected characters rearrange themselves as well. First, the characters enlarge and fly out towards the audience, creating a feeling of three-dimensional immersion. Then, they form vertical rows scrolling across the stage that are equally reminiscent of endless columns of sutras carved into stone and matrices of binary code, and finally, dissolve into a field of shimmering white-on-black dots before returning to the calm blue of the earlier projected waves. Following this, a long, thin panel on the stage is suddenly illuminated, but with a gray light. Actors, their bodies covered with flowing, billowing white sheets, move across the space as other bodies, crumpled and covered in similar sheets, lay on the ground behind them. The lighting effects make the bodies and landscape appear to be in gray tones, and, from the vantage point of the audience, it is nearly impossible to determine whether this the action is live, or projection of black-and-white video. [Figure 45]

These are subtle moments in the midst of constantly moving images, but the projected blizzard clearly echoes Feng's use of television static in his earlier, independent work and the black-and-white scene his experimentation with blurring the lines between live and mediatized bodies onstage. It is uncertain, of course, whether this break in an otherwise dazzling parade of visual images and the immersive intoning of Buddhist chant reads as an intervention to audience

⁹³ Video clips are available on the official *Encore Mount Wutai* website: <http://www.yjwts.com/index.php?m=content&c=index&a=lists&catid=59>



Figure 44 Swirling projected characters, *Encore Mount Wutai*, 2014 (Source: Screenshot from video, Encore Mount Wutai website, <http://www.yjwts.com/index.php?m=content&c=index&a=show&catid=59&id=97>)

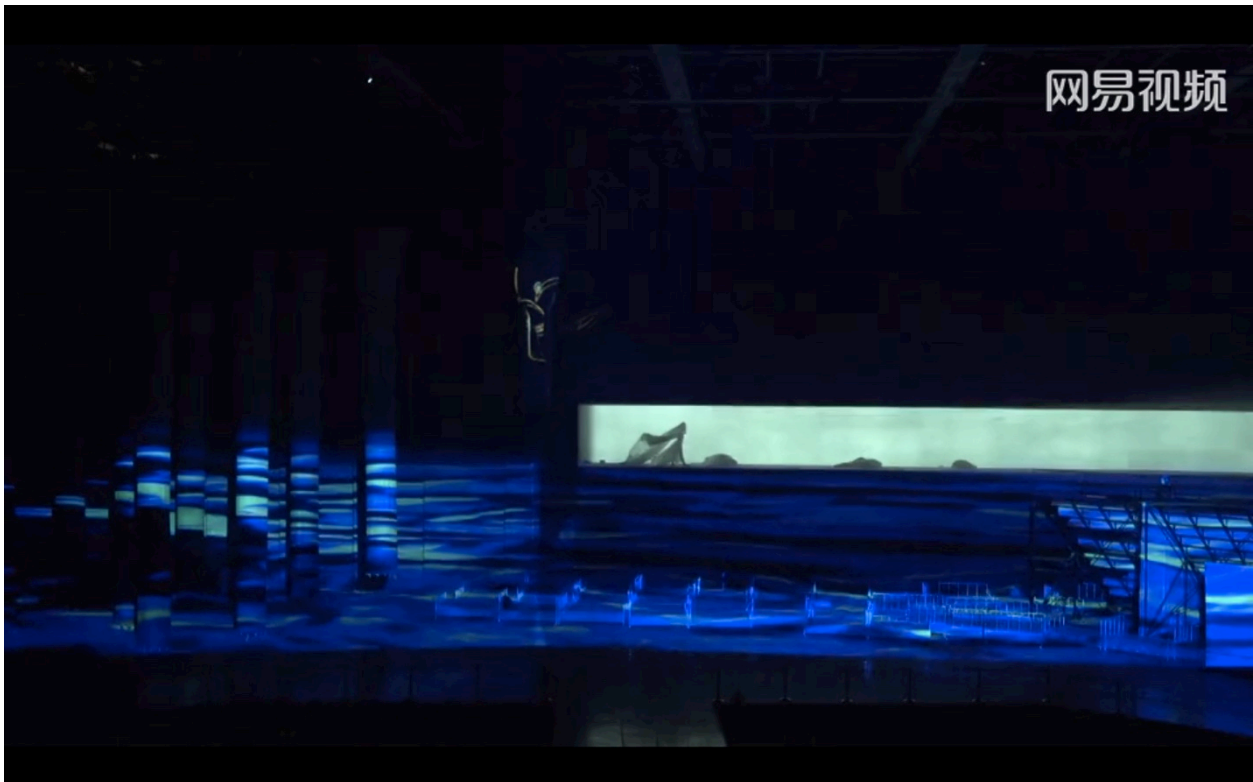

Figure 45 Illuminated panel onstage, *Encore Mount Wutai*, 2014 (Source: Screenshot from video, Encore Mount Wutai website, <http://www.yjwts.com/index.php?m=content&c=index&a=show&catid=59&id=97>)

members. However, coupled with the production's overall claim to be oriented toward encouraging contemplation, rather than passive observation, it suggests that this production, although part of the Impressions Series, is something more than a multimedia simulacrum of Buddhist religious culture.

Technical Familiarization: Multimedia Critique as Global Idiom

We can read the work of Wang Chong and Feng Jiangzhou, as I have done above, as addressing some of the central questions raised by the dominant multimedia performance practices in the PRC today. At the same time, some of the issues their work touches upon are hardly unique to China-specific concerns. Rather, they speak to some of the central concerns of technology and live performance that have been debated in theory and explored in theater, performance art, and visual art in the last half-century. In particular, their heavy reliance on technologies of reproduction and mediatization—projected still and moving images, manipulated sound, live-feed cameras—connect Wang and Feng's work with the debates on related topics in Western theater and performance theory.

To be sure, these issues are also important in Chinese discourse. The related concepts of *xianchang* 現場 and *xianchangxing* 現場性—with *xianchang* literally translated as “on the scene”—have risen to prominence across the fields of theater, visual arts, and documentary filmmaking in China the last two decades. Rossella Ferrari, for example, has argued for both the general importance of immediacy and liveness to the Chinese avant-garde in the 1990s and 2000s, as well as for the specific significance of *xianchang* in the work of Meng Jinghui. She writes that “the immediacy of the performance event as a nearly unrepeatable occurrence became a fundamental tenet of avant-garde praxis” in the 1990s and that in the following decade “notions

of liveness, improvisation and loosely scripted performance still form the core working philosophy of such groups as Pangniao jutuan 胖鳥劇團 (Fat Bird Theatre, from Shenzhen), Caotaiban 草台版 (Grass Stage, from Shanghai) and Zhi laoshu gongzuoshi 紙老虎工作室 (Paper Tiger Studio) and Shenghuo wudao gongzuoshi 生活舞蹈工作室 (Living Dance Studio, from Beijing).⁹⁴ The last of these, Living Dance Studio, also has ties to the documentary filmmaking world, and in particular, to filmic definitions of *xianchang*. One of its core members, Wu Wenguang 吳文光, is also a central figure in China's New Documentary Film Movement, and has become known as a theorist of *xianchang*—in this context, translated as “on location”—in filmmaking. Film scholar Zhang Zhen has paraphrased Wu's approach to documentary *xianchang* as follows:

...*xianchang* represents a cinematic operation in the ‘present tense’ by virtue of ‘being present on the scene.’ The essence of *xianchang* is embedded in the sensitivity toward the relationship between subject and object, and in a conscious reflection on the aesthetic treatment of this relationship. It is a cinematic practice and theory about space and temporality, which is charged with a sense of urgency and social responsibility.⁹⁵

More broadly, Zhang Zhen has also argued that the concept of *xianchang* captures the spirit of an entire “urban generation” of filmmakers.⁹⁶ Zhang describes the aesthetics of these films as emphasizing a look of liveness and actuality, aided by the use of video technology, and their

⁹⁴ Ferrari, *Pop Goes the Avant-Garde*, 59.

⁹⁵ Zhang Zhen, “Building on the Ruins: The Exploration of New Urban Cinema of the 1990s,” in *Reinterpretation: A Decade of Experimental Chinese Art (1990-2000)*, ed. Wu Hung, Wang Huangsheng, and Feng Boyi (Guangzhou: Guangzhou Museum of Fine Art, 2002), 116; Wu Wenguang 吳文光, *Xianchang (di Yi Juan)* 《現場》 (第一卷) (Tianjin: Tianjin shehui kexue yuan, 2000).

⁹⁶ Zhang Zhen, “Introduction: Bearing Witness: Chinese Urban Cinema in the Era of Transformation (Zhuanxing),” in *The Urban Generation: Chinese Cinema and Society at the Turn of the Twenty-First Century*, ed. Zhang Zhen (Durham, NC: Duke University Press, 2007), 19.

poetics (and politics) as invested in capturing the stories of ordinary people, often played by amateurs.⁹⁷

Many of the principles articulated in Wu Wenguang's theory of *xianchang*, as well as his performance of the fraught nature of recorded (or public) testimony, are echoed in Meng Jinghui's understanding of *xianchang*. As relayed by Rossella Ferrari, Meng explains as follows:

... of the two characters composing the Chinese word for 'theatre' (*juchang*), *ju* – by which he means the stage – belongs to author and actor, whereas *chang* belongs to director and spectator (according to an interview with the author on 7 August 2005) in Beijing). *Chang* encapsulates the physical and psychical space in which director and spectator meet and connect to one another. *Chang* evokes the image of a magnetic field (*cichang*) in which energies are mutually transmitted, of a participative site (*changsuo*) for exchange, or a public space or scene for spectacle (*changmian*). He also stresses the significance of conveying a sense of being 'on the scene' (*xianchang gan*)—an impression of presence, process, testimony and immediacy.⁹⁸

From Meng's comments, however, the primary difference between filmic *xianchang* and theatrical *xianchang* also becomes clear: whereas in documentary film the *xianchang* moments of concern occur during the process of filmmaking, and does not involve spectators, the *xianchang* of the theater is linked primarily to moment of performance. Moreover, in film, the medium is essential to transmitting the on location, live event—what Zhang Zhen calls a “history of the present”—to its audience. By contrast, media onstage, filmic or otherwise, can actually pose a threat to the liveness of the theater.

⁹⁷ Zhang, “Bearing Witness,” 19-20. For other discussions of *xianchang* in documentary film and realism in filmmaking, see: Luke Robinson, “From ‘Public’ to ‘Private’: Chinese Documentary and the Logic of *Xianchang*,” in *The New Chinese Documentary Film Movement*, ed. Chris Berry, Lu Xinyu, and Lisa Rofel (Hong Kong: Hong Kong University Press, 2010), 177–94; Qi Wang, “Performing Documentation: Wu Wenguang and the Performative Turn of New Chinese Documentary,” in *A Companion to Chinese Cinema*, ed. Yingjin Zhang (Malden, MA: Wiley-Blackwell, 2012), 299–317; Chris Berry, “Getting Real: Chinese Documentary, Post-Socialism,” in *The Urban Generation: Chinese Cinema and Society at the Turn of the Twenty-First Century*, ed. Zhang Zhen (Durham, NC: Duke University Press, 2007), 115–34.

⁹⁸ Ferrari, *Pop Goes the Avant-Garde*, 240.

Precisely this concern has been posed by Chinese theater scholars and theorists discussing the fate of theater in the face of an increasingly technology- and media-saturated society. A “theater crisis” debate that took place from 2002-2004 in mainland Chinese theater circles, for example, reveals an underlying anxiety about the nature and future of theater in China catalyzed by the arrival of the fully digital 21st century.⁹⁹ Primarily concentrated in *Zhongguo xiju* 《中國戲劇》 (Chinese Drama) in a series of articles on “the fate of contemporary theater” (*dangdai xiju zhi mingyun* 當代戲劇之命運), the debate also echoed in other-prominent theater and literary journals such as *Xiju yishu* 《戲劇藝術》 (Drama Arts, journal of STA) and *Wenyi zhengming* 《文藝爭鳴》 (Literature and Art Contend). It was certainly was not the first, nor the last, arrival of a crisis point in Chinese theater circles.¹⁰⁰ Late Qing and early Republican literature and theater periodicals were peppered with efforts to rehabilitate classical drama and articles advocating wholesale importation of Western dramatic forms; a few decades later, the spread of cinema ignited debates over the distinctions between film and theater, as well as fears of theater’s obsolesce. Perhaps the most similar rhetoric can be found in articles published in the mid-1980s, as the theater struggled to recover from its subjugation to the mandate of the Model Operas during the Cultural Revolution, and in the mid-1990s, as theater, especially *huaju* *huaju*, faced the oppositional pressures of commercialization and a more polemical avant-garde.

⁹⁹ There have been a series of “theater crises” throughout the 20th century. Another significant one took place in the 1980s and was spurred primarily by economic reforms. See Ferrari, *Pop Goes the Avant-garde*, 36-37; Chen Jide, *Zhongguo dangdai xianfeng xiju*.

¹⁰⁰ Li Yutian 李玉田, “Guanyu batuo xiju weiji zhi Yuyujian 關於擺脫戲劇危機之愚見,” *Zhongguo xiju* 《中國戲劇》, no. 9 (2003): 8-9; Hong Hong 洪宏, “Shi xiju zou xiang molu haishi xueli wuruqitu? Ye tan suowei dangdai xiju de zhongjie 是戲劇走向末路還是學理誤入歧途？也談所謂當代戲劇的‘終結,’” *Wenyi zhengming* 《文藝爭鳴》 6 (2005): 115-18; Xu Zhen 徐震, “Guanyu ‘xiju weiji’ de sikao 關於‘戲劇危機’的思考,” *Xiju* 《戲劇》 2 (2014): 126-34.

These latter theater crises explicitly root themselves in the problems faced by the traditional and live theater in a contemporary, commercial, and mediatized age.¹⁰¹ Television, KTV, and the internet come under considerable suspicion, while many critics struggle to reaffirm the uniqueness of the “live interaction” (*xianchang jiaoliu* 現場交流) in the theater. The article that set off the most recent debate, by well-respected playwright and actor Wei Minglun 魏明倫, for example, primarily attempts to identify the reasons for a decline in theater audiences around the turn of the 21st century, but in doing so, also highlights the irreproducibility of performance and live interaction between audience and actors as fundamental characteristics of the theater. According to Wei, these seemingly valuable characteristics ironically have led to theater’s decline, as anything irreproducible cannot be mass marketed and media-saturated audiences have lost their desire for live connection.¹⁰² These points are further developed later in the debate in articles by playwright and provincial-level cultural bureaucrat Ruan Runxue 阮潤學 and Ma Ye 馬也, a scholar based at the Chinese National Academy for the Arts (*Zhongguo yishu yanjiu yuan* 中國藝術研究院). Ruan argues for an “aesthetic delight” (*shenmei yuyue* 審美愉悅) of interaction between live performer and audience as unique and essential to the theater.¹⁰³ Ma attempts to distinguish the kind of live interaction of a theatrical performance from the

¹⁰¹ Yi Hongxia 易紅霞, “Duomeiti xiju: ke-mei shidai de xinxing xiju 多媒體戲劇：科媒時代的新型戲劇,” *Nanguo hongdou* 《南國紅豆》 S1 (2004): 48–51.

¹⁰² Wei Minglun 魏明倫, “Dangdai xiju zhi mingyun: zai yuelu shuyuan yanjiang de yaodian 當代戲劇之命運：在岳麓書院演講的要點,” *Zhongguo xiju* 《中國戲劇》 12 (2002): 4–6.

¹⁰³ Ruan Runxue 阮潤學, “Shanyu duoyanghua de shidai--ye tan dangdai xiju zhi mingyun 善於多樣化的時代——也談當代戲劇之命運,” *Zhongguo xiju* 《中國戲劇》 6 (2003): 13–14.

superficial engagement of online games and karaoke singing, but like Wei expresses concern that audiences may in fact prefer the latter.¹⁰⁴

In several other articles focused on the particular predicament of *xiqu* forms, authors emphasize the importance of the physicality of the performing arts, especially the conventions and skills of “singing, speaking, acting, and combat” (*chang nian zuo da* 唱念做打). Like the actor-audience connection, these physical feats are rooted in bodily presence. This presence is paradoxically connected to the aesthetic of “virtuality” (*xuni* 虛擬), a term used to describe the way in which the actor’s *non*-realistic gestures create an imaginary world onstage. The target aesthetic is not wholly virtual, as in virtual reality, but rather an ideal blending of the real and imaginative. As one article on the topic notes, *xuni* in performance is a formal virtuality that operates in the realm of aesthetics, whereas virtual reality uses digital methods to create a “hyperreality” in which it is difficult to separate real from fake.¹⁰⁵ Most importantly, even this privileging of a ‘virtuality’ rooted in traditional performance aesthetics does not deny the liveness; in fact, successful creation of this kind of *xuni* depends upon nothing other than the live body of the actor and his/her real-time connection with the audience.

One might imagine that such anxiety over competition from other forms of media and entertainment outside the theater would engender a reaction against the use of multimedia within the theater. Yet, as later scholarship on multimedia trends in contemporary Chinese theater note, this debate was a crucial turning point in the development of attention—both positive and negative—to issues in this vein. Several scholars have even argued that this national debate

¹⁰⁴ Ma Ye 馬也, “Dangdai xiqu mingyun zhi duanxiang 當代戲劇命運之斷想,” *Zhongguo xiqu* 《中國戲劇》 6 (2003): 8–12.

¹⁰⁵ Zang Nuo 臧娜, “Liang zhong ‘xuni’ de jianxing jiedu yu shiyu jiaorong-- jiyu duomeiti jingju yinyue xiqu de lilun sikao 兩種‘虛擬’的間性解讀與視域交融——基於多媒體京劇音樂戲劇的理論思考,” *Zhongguo xiqu xueyuan xuebao* 《中國戲曲學院學報》 35, no. 4 (November 2014): 109.

called the theater world's attention to the growing relevance of media and technology to contemporary society.¹⁰⁶ Certainly, concerns persist; recently Nanjing University theater scholar Sun Xinyu has argued that with video projection onstage, there is no way to establish a two-way interaction with the audience; he also thinks that presence of a 'reproducible' medium onstage may negatively affect the "liveness" (*xianchang zhiguan xing* 現場直觀性) of theater. Sun's invocation of *xianchang* here invokes the doubled cinematic and theatrical discourses surrounding the term, but for Sun, multimedia is at best a double-edged sword for the theater.¹⁰⁷

The discourse arising out of these debates and responses to subsequent practical experimentation with media onstage follows close on the heels of another famous argument between US-based performance studies scholars Philip Auslander and Peggy Phelan. The debate between Auslander and Phelan took place in the mid-late 1990s, with Phelan insisting upon "representation without reproduction" as defining performance and Auslander refusing a meaningful distinction between the mediatized and the live.¹⁰⁸ For Phelan, the stakes are high in defending theater's ontological territory; radical, performative politics depend on it. Auslander, in contrast, plays the rational realist in the debate, arguing that it is all a matter of cultural economy.¹⁰⁹ These perspectives are less clearly articulated but nonetheless intertwined in early

¹⁰⁶ Yi Hongxia, "Duomeiti xiju: ke-mei shidai de xinxing xiju"; Fan Feiyan 樊飛燕 and Han Shunfa 韓順法, "Xin meiti shidai wutai yishu de qipa--duomeiti xiju 新媒體時代舞台藝術的奇葩——多媒體戲劇," *Wenhua yishu Yanjiu* 《文化藝術研究》 5 (2009): 190–94. Reprinted in *Qilu yiyuan* 《齊魯藝苑》 2 (2010): 40-43 and *Wenju* 《溫居阿藝術研究》 2, iss. 5 (2009): 190-194.

¹⁰⁷ Sun Xinyu 孙昕昱, "Xiandai huaju yanchu zhong de shanbian--duomeiti yingxiang dui xiandai huaju de yingxiang chutan 現代話劇演出中的嬗變——多媒體影像對現代話劇的影響初探," *Linqu jiaoxue* 《林區教學》 12 (2008): 111–12. See also Fan Feiyan and Han Shunfa, "Xin meiti shidai wutai yishu de qipa--duomeiti xiju."

¹⁰⁸ Auslander, *Liveness*; Phelan, *Unmarked*.

¹⁰⁹ In a distillation of his arguments in *Liveness*, Auslander defines cultural economy as "a realm of inquiry that involves both the real economic relations among cultural forms, and the relative degrees of cultural prestige and power enjoyed by different forms." Philip Auslander, "Liveness, Mediatization, and Intermedial Performance," *Degrés: Revue de Synthèse À Orientation Sémiologique* 101 (2000): 1–12.

21st century Chinese articles on “the fate of theater”: scholars’ insistent emphasis on audience-performer interaction and the bodily aspects of *xiqu* parallels Phelan’s key points, whereas their concerns over the marketability of live performance and its cultural status in relation to a proliferation of other entertainments echo Auslander’s. However, whereas Phelan sees radical potential in live performance, Chinese scholars paradoxically link the most ephemeral of characteristics to the preservation of tradition and the codification of a distinctly Chinese cultural sensibility. The triumph of mediatization over liveness therefore threatens nothing less than the survival of national culture.

While differing in these key ways, the pervasive concern over liveness in the theory and practice of contemporary Chinese theater artists connects their work to a larger, global sphere of theater with similar concerns. As is clear from the proliferation of scholarship in the areas of multimedia performance analysis, intermediality and theater, and digital performance in the last two decades, Auslander and Phelan were really only the beginning. And while these various theorists have moved beyond the paradigm of mediatization *versus* liveness, topics such as immediacy, immersion, and virtuality have continued to dominate discussion. At the same time, the multimedia and intermedia techniques that were once cutting-edge in the work of collectives like the Wooster Group in the 1970s have now become ubiquitous and familiar in experimental and mainstream theater alike, around the world. By touching upon these seemingly universal theoretical concerns in an aesthetic idiom that is familiar worldwide, Wang Chong and Feng Jiangzhou parlay their work into something that is appealing and marketable beyond China.

This can be seen in other areas of their work, besides the ways in which they directly engage with the theme of liveness vs. mediatization. In terms of technique, the live-feed video in Wang Chong’s productions shares a general aesthetic and critical impulse with many well-

known uses of similar onstage media in Western productions, from Station House Opera to the Builders Association to work by British director Katie Mitchell. Mitchell's use of live-feed video, in particular, has been an important influence for Wang Chong; he has seen her work at international festivals and her *Fräulein Julie* toured to Tianjin and Beijing in April and May 2014. In terms of critique, while the performance history of *Thunderstorm* deconstructed by Wang Chong's *Thunderstorm 2.0* may be unique to China, the state of technologization and distraction that he simultaneously targets is certainly not. It is a theme intelligible to audiences in developed countries around the globe, and this may explain why, when Wang Chong tours his productions in East Asia, Europe, the United States, and Australia, he tends to favor pieces less "Chinese" in their allusions. *e-Station*, for example, has been performed in New York (2009), Mont-Laurier, Quebec (2009), and Edinburgh (2012). Likewise, *Ibsen in One Take* toured to Rotterdam, Oslo and Adelaide, Australia, and *Ghosts 2.0* has toured to Seoul, Tokyo, and Taipei. Both pieces were developed as part of the "Ibsen in China" project, a collaboration between the Norwegian Embassy in Beijing, the Norwegian Consulate General in Shanghai and Guangzhou, and an organization called Ibsen International.¹¹⁰ Some of the international tours were co-produced by Ping Pong Productions, a Beijing-based arts management company founded by American arts activist Alison Friedman.¹¹¹ *Thunderstorm 2.0*, in contrast, had only toured to Taipei before 2016; this year, however, it was performed in Isreal and will travel to Indiana University in the U.S. in March 2017.

In addition, when Wang Chong turns his onstage, live-feed video cameras on Ibsen, he is

¹¹⁰ For more information, visit the Ibsen International website at: <http://ibseninternational.com/>

¹¹¹ For more information, visit the Ping Pong Productions website at: <http://www.pingpongarts.org>

participating in a by-now well-established trend in international theater.¹¹² As with Shakespeare, Chekhov, and Stindberg, there may still exist canonical ways of performing Ibsen, but his status as a master of modern drama has made his oeuvre more, not less, likely to be reinterpreted and reinvented by theater artists working in a postmodern or postdramatic mode. For instance, the adaptation *Dollhouse* by Mabou Mines (2003) transforms the play into a full-fledged melodrama and exaggerates the gendered power imbalance of the original script by casting an exceptionally tall woman as Nora and little people as the male characters. Highlighting the theme of public scrutiny also plays into international perceptions of contemporary China as a surveillance state. Audience members—especially international audience members—cannot help thinking of the constant news reports on state monitoring of internet activities, the house arrests of Ai Weiwei and other artist-dissidents, and the appearance of translated “banned in China” novels on the international market. Even the choice of Ibsen is intriguing here, as Ibsen’s work was famously embroiled in battles over theater censorship in late 19th-century Europe.¹¹³ There is no reason to doubt Wang’s claims that he did not *intend* to critique censorship with this production, but this tidy coincidence does point to one of the overarching characteristics of his work and his recent success on the world stage. That is to say, Wang Chong cleverly deploys technology onstage in ways that resonate with the technical and critical applications of these media in international

¹¹² One example, and a direct inspiration to Wang Chong, is the work of British director Katie Mitchell. Her multimedia *Fraulein Julie*, based on *Miss Julie* by August Strindberg, toured to Tianjin and Beijing in April-May 2014 and caused a certain amount of excitement in theater circles. See for example Shi Ming 石鳴, “Zhuli xiaojie: yinxiangpai de Sitelinbao 《朱麗小姐》：印象派的斯特林堡,” *Sanlian shenghuo zhoukan* 《三聯生活週刊》, May 29, 2014, <http://magazine.sina.com/gb/lifeweek/785/20140528/1638124458.html>. Wang Chong references the production in a talkback following *Thunderstorm 2.0*, recorded in “Jiu cheng guanzhong renke chuanxinban *Leiyu* 九成觀眾認可創新版《雷雨》” *Xin Jing Bao* 《新京報》 July 23, 2012

¹¹³ *Ghosts* in particular was deemed “morally deranged” in England. “Censorship,” *The Cambridge Guide to Theatre* (Cambridge, UK: Cambridge University Press, 1995).

experimental theater practice *and* anticipate the targets of critique that international audiences will expect to see, given their politics.

The result is a promotion of a national culture far different from that envisioned by mainland Chinese theater scholars and critics of the early 2000s. Whereas *xiqu* forms and the embodied liveness of their performances are typically seen as the most “Chinese,” especially in comparison to the “imported” (*bolai pin* 舶來品) genre of *huaju*, the appeal of Wang Chong’s productions lies in the fact that they are unique *among* other forms of Chinese theater. The fact that Wang is one of few Chinese artists to use live-feed video effectively contributes to his appeal to international festivals and collaborations. In addition, despite having refused to even use a smartphone for a number of years and currently being on a hiatus from Facebook and Weibo, Wang Chong has carefully crafted for himself and his theater company a media presence that is intelligible across different cultural contexts.¹¹⁴ His website is consistently updated and includes Chinese, English, and Japanese versions, he frequently accepts interviews and publicizes video trailers of his pieces. Therefore, while *Thunderstorm 2.0*, *Ibsen in One Take*, and *Ghosts 2.0* all deploy live-feed technology in order to critique the effects of media and technology on art and life, Wang Chong also depends on these very technologies for both his artistic experimentation and professional success. Likewise, even as he takes to task the Chinese dramatic tradition, his popularity abroad relies at least in part on his very unique position within that ongoing lineage.

Feng Jiangzhou is perhaps less savvy in his international engagement, but he too has been outward-oriented since the beginning of his theater career and recently has begun to present work in Europe. His earliest collaborations with Meng Jinghui were developed with Zuni Icosahedron

¹¹⁴ In 2016, Wang posted on Facebook that he planned to take a one-year break from social media. He did not delete his accounts or profiles, but has not posted any updates to either Facebook or Weibo since early January 2016.

(Hong Kong) and Matthias Woo as intermediaries, and more recently, one of his Reading-Mistake pieces toured to Avignon and another piece, *Wei lianjie* 微鏈接 (Microconnection) was performed in Kassel, Germany. He also, like Wang Chong, has participated in workshops and productions sponsored by Ibsen International, such as a recent opera adaptation of *A Doll's House*, entitled *Nala* 《娜啦》 (NORA). Most recently, from 2013-2015, he and Zhang Lin worked on a production called *Xunzhao yongqi* 《尋找勇氣》 (Looking for Courage), which was workshopped at the Mustard Seed Garden in Beijing (Beijing jiezi yuan 北京芥子園) in June 2014 and premiered August 26-29, 2015 in Copenhagen, Denmark.

The Mustard Seed Garden is an interesting intermedial and international reference in and of itself; in classical painting, the *Jiezi yuan huapu* 《芥子園畫譜》 (Mustard Seed Garden Manual of Painting, 1679) was a woodblock-print book that illustrated formal composition and brushstrokes, and in 2011 visual artist Xu Bing 徐冰 created a landscape scroll made up of elements from the *Mustard Seed Garden Manual of Painting* for the “Fresh Ink” exhibit at the Museum of Fine Arts in Boston. Likewise, the location of the premiere proper demonstrates Feng’s ongoing commitment to public art and brings us back to concepts of environmental performance, as contrasted with the Impressions Series.¹¹⁵ Just as his *Eight Sounds* installation was set in a high-tech development park in Shanghai, the Copenhagen production took place in situ in the city’s development district of Ørestad. As descriptions of the production note, *Looking for Courage* was a piece of environmental multimedia theater that required audiences to wear a radio receiver earpiece to guide them through different spaces in the Tietgen Student Residence

¹¹⁵ Moreover, Tietgen is envisioned as a kind of utopian community created through architecture—a “residence hall of the future” whose core mission is strikingly reminiscent of similar projects in collective building and living from the early- to mid-20th century. See the venue website at: <http://tietgenkollegiet.dk/en/the-building/>



Figure 46 Environmental multimedia in *Looking for Courage*, 2015 (Source: Sifenlv website, <http://sifenlv.com/project/detail/?lang=c&type=4&id=135&page=>)

Hall, following the play's protagonist as she moves through her own quest.¹¹⁶ [Figure 46] The earpieces and other multimedia effects—namely lighting and projections—envelop these audience members and bring them into the world of the performance, making them participants. Moving far beyond the traditional relationship between performer and audience in a proscenium-style theater, or even the more porous boundaries of Chinese temple or teahouse performance, the technology in this production aids in the disruption of preconceived notions about this relationship, those boundaries. At the same time, interference also works in the other direction by simultaneously transforming a semi-private space, a functioning student dormitory, into both a place of public performance and the imaginative world in which that performance takes place.

¹¹⁶ “Looking for Courage Produced by OperaNord, Copenhagen & Sifenlv New Media Studio, Beijing,” *Kobenhavens Internationale Teater*, n.d., http://www.kit.dk/2015/uk-OPERA_NORD.html.

Where Wang Chong uses high-tech staging and multiple media to play to international theatrical taste and foreign assumptions about Chinese politics, Feng Jiangzhou brings a more idiosyncratic vision rooted in his diverse artistic experiences and philosophic inclinations to bear on transnational collaboration. He and Zhang Lin's reputation as new media artists and ability to successfully employ technology at a high level, in a sophisticated way moreover gives him the vocabulary to communicate with theater artists working in a similar mode in different contexts. The success of the piece is, moreover, intensely rooted in presence and place, as the artists involve invested significant time in traveling to the different locations of workshop and performance, and audience members committed to a very corporeal spectatorial experience. Feng's approach to creating immersive environments, then introducing moments of disruption and interference, moves his work beyond its role as a part of and response to the local context and into a more adaptive, responsive, and collaborative direction—successfully achieving some of the more utopian dreams for what technology can do for art, for the world, and for humanity.

Conclusion

We have long since accepted that artists, authors, and other cultural producers exist in complex and complicit relationships with the political systems, economies, and technologies surrounding them. Ideas of pure “art for art's sake” have been complicated, and, especially in China, theater and performance in particular have long been instrumentalized in the service of politics. Set against the backdrop of a world in which spectacular multimedia performance is the gold standard, the oeuvres of Wang Chong and Feng Jiangzhou demonstrate precisely how inextricable technological tools and targets of critique have become. *Thunderstorm 2.0*, *Ibsen in One Take*, and *Ghosts 2.0* all deploy the technologies of live-feed videography and onstage

projection as a double-phalanxed critique against the Chinese dramatic tradition and the media-saturated nature of contemporary everyday life. In particular, the democratization of perspective and the enlivenment of the camera as an actor onstage go far to disprove anxieties over the stultification of art and the waning importance of “liveness” to today’s audiences. However, Wang toes a fine line between control of his technologies and being subjected to their control in the interest of extending his innovations, critiques, and recognition. Thus, the question remains as to whether his *yidu gongdu* 以毒攻毒 (fighting fire with fire, or literally, to treat poison with poison) strategy will succeed its critical edge, or become unfortunately mired at a more superficial level of technology for technology’s sake.

Feng Jiangzhou, in contrast, succeeds in a more mature artistic application of multimedia technologies and offers a more subtle form of critique. His work demonstrates how artists who are directly involved in state-sanctioned and commercial productions—more intimately entangled with the political and economic apparatus—may in fact be better positioned to subtly critique and disrupt the system. In addition, while both of these artists are deeply enmeshed in their local context, the fact that they work in a global aesthetic idiom and address seemingly universal concerns related to technology and live performance also perfectly positions them to engage with international collaborators and a broader audience. This recent trend is not merely a product of new technological advances in the new millennium, but rather is the latest iteration of the longstanding and complex process of interaction among forces of technology, art, and politics in modern China that this dissertation has demonstrated.

Conclusion

On the evening of September 3, 2015, an audience of prominent politicians gathered in the Great Hall of the People for *Shengli yu heping* 《勝利與和平》 (Victory and Peace), a spectacular multimedia song-and-dance performance commemorating the 70th anniversary of China's victory in the Second Sino-Japanese War. The performance followed in the tradition of the epic historical productions that often mark major national holidays in the PRC and concluded a day of ostentatious military parades that, like many state celebrations before, passed along Chang'an Avenue in front of Tiananmen.¹ In ninety minutes, over twenty different vignettes jump disjointedly from gruesome depictions of massacre and destruction, exaggerated by large-scale moving projections, to romanticized ballets of Communist soldiers to cloying paeans to the present era of peace and prosperity, with children singing and a montage of images depicting a diverse Chinese nation in the background.

One vignette in particular stands out in light of the concerns of this project: about fifteen minutes into the production, a large chorus of Chinese laborers appears beneath video from the Japanese invasion of Manchuria in 1931. Text runs over the historical footage, while a voice-over reads: "A statement by the Communist Party of China on the Brutal Occupation of the Three Northeast Provinces by Japanese Imperialists... The Japanese Imperialists have invaded China and are killing more and more Chinese people... Let us have our weapons ready to teach

¹ Xiaomei Chen has recently written on the historical works performed in honor of national anniversaries: *The East is Red* (1964), *Zhongguo geming zhi ge* 《中國革命之歌》 (Song of the Chinese Revolution, 1984) and *Fuxing zhi lu* 《復興之路》 (The Road to Revival, 2009). These three productions, which also took place in the Great Hall of the People, are labeled as "music-and-dance epics" (*yinyue wudao shishi* 音樂舞蹈史詩), a title that seems reserved for a very small number of works. In contrast, *Victory and Peace* was given the lesser label of "literature-and-arts gala" (*wenyi wanhui* 文藝晚會). Xiaomei Chen, "Performing the 'Red Classics': From *The East is Red* to *The Road to Revival*," in *Red Legacies in China: Cultural Afterlives of the Communist Revolution*, ed. Jie Li and Enhua Zhang (Cambridge, MA: Harvard Asia Center Publications, 2016).



Figure 47 Choreography to the lyrics “Roar, Yellow River” (*nuhou ba, Huang he* 怒吼吧黃河) during the 2015 performance *Shengli yu heping* 《勝利與和平》 (Victory and Peace). (Source: Screenshot from CCTV broadcast, <https://youtu.be/Rv-EZXM5kAA>)



Figure 48 *Nuhouba, Zhongguo!* (Roar, China!) woodcut by Li Hua, 1936 (Source: The Huntington Archive via APHELIS, <http://aphelis.net/li-hua-china-roar-1936/>)

the Japanese aggressors a serious lesson!”² With that, the chorus of dancers comes to life, moving in slow motion as the lights shift to illuminate their half-clothed bodies and the background projection cuts to moving images of a raging river. As if in imitation of Li Hua’s famous *Roar, China!* woodblock print, they contort their faces and begin to sing stridently, “Roar, Yellow River!” (*nuhouba, Huang he* 怒吼吧黃河).³ [Figures 47-48] Meanwhile, the projections spill across the stage and into the auditorium, covering every inch of the walls and ceiling. As the music swells in an operatic register, the audience is fully immersed in torrents of indignation and revolutionary conviction pouring forth from the stage.

² Translation from surtitles in performance recording, paired with original Chinese text: 中國共產黨為日本帝國主義強暴佔領東三省事件宣言 (1931.09.20) 中國工農兵勞苦群眾們...日本帝國主義公開出兵中國了, 強暴佔領奉天暗洞營口, 更搭規模的屠殺中國民眾了...讓我們一致動員武裝起來, 給日本強盜以嚴重的回答! CCTV, *Shengli yu heping*, September 3, 2015, https://youtu.be/Rv-EZXM5kAA?list=PLj6yQdgFyUsApQktGNJkAdltbNIQ_l_ixk&t=1164 online video recording.

³ Video clip: https://youtu.be/Rv-EZXM5kAA?list=PLj6yQdgFyUsApQktGNJkAdltbNIQ_l_ixk&t=1164



Figures 49-50 *The Revolutionary Model Play 2.0* at LASALLE College of the Arts, Singapore International Festival of Arts 2015, September 2-4, 2015 (Source: Photo courtesy of LASALLE College of the Arts)

That same evening, a few thousand miles away, a very different audience filed into the Singapore Airlines Theater at LASALLE College of the Arts for a very different performance: Wang Chong's latest provocation, *Yangbanxi 2.0* 《樣板戲 2.0》 (The Revolutionary Model Play 2.0).⁴ Written by an up-and-coming New York-based Chinese playwright, Zhao Bingbao 趙秉昊, *Model Play 2.0* uses a sequence of fictitious interviews with artists, political figures, historians, and Jiang Qing herself to present a fragmented perspective on the creation and consequences of the Cultural Revolution *yangbanxi*. True to form, Wang Chong adapts the script for a multimedial stage by adding several video cameras and large-scale projections. [Figures 49-50] This time, the projection screen acts as an agent of double remediation, with the live feed video layered on top of reproduced newspaper pages, and the cameras alternately document "historical" moments and the direct confessions of the characters. Throughout, a playwright/documentary

⁴ Video clip: <https://vimeo.com/140903555>

maker wanders in and out of scenes involving historical personages, at times interacting with them and at times observing, often with his own camera in hand.

Commissioned by the Singapore International Festival of Arts, *Model Play 2.0* is a work that could not be staged in the PRC due to its sympathetic portrayal of Jiang Qing and depiction of Cultural Revolution violence. Its meditation on the inherent difficulty of reconstructing any historical narrative provides a stark contrast to the clear lines drawn between good and evil in *Victory and Peace*. Where *Model Play 2.0* gives individual voice to the many players complicit in the creation of the *yangbanxi*, *Victory and Peace* flattens the complexities of another important historical moment into perfectly composed stage tableaux. Yet, at the same time, one cannot help but compare the political pitches that the two plays make and how they make them. Unabashedly propagandistic, *Victory and Peace* panders to the Party's current policies of renewed control over media and increased nationalistic antagonism towards certain foreign countries. More serious in his artistic pursuits, Wang Chong nonetheless seems to orient his work toward the tastes—both aesthetic and political—of cosmopolitan audiences that have come to expect the freedom of speech afforded by international backing to produce a certain kind of dissidence. And in both, the marriage of live and mediated performance proves essential to both their artistic success and the communication of their underlying messages about the role of theater in the representation of national and cultural history.

These two performances, which took place at the same time in the recent past, provide one final illustration of the close relationship and deep tensions between theater and technology in modern China that have been the objects of this study. As I have argued throughout this dissertation, technological innovations have propelled an instrumentalization of theater in modern China that both transforms theater into a tool of ideology and provides artists with a

means of resistance to that cooptation. At the same time, while the technologization of performance may be ubiquitous in China, it is not hegemonic—instead, it gives rise to applications at all points along the spectrums of artistic subtlety and political nuance. As discussed in the Introduction, the linking of theater, especially large-scale spectacle, with political power was not a new concept to the modern era; rather, we might say that it was the modern scientific promise of a dependable link between cause and effect that invested theater with new promise as a tool of revolution. In Chapter 1, this is first demonstrated in the case of *Roar, China!* in 1930s Shanghai, wherein we can observe the collision of theories of stage technology with still-forming concepts of modern knowledge and modern theater. At this formative moment in the history of modern Chinese theater, the idea that lighting, sound, and special effects, if deployed properly, could produce predetermined affective responses in audience members fueled both experimentation in staging and the use of theater as a tool for agitation. Attention to technical detail filtered even into dramaturgy itself, contributing to what would become a veritable tradition of lengthy and realistic stage directions in the *huaju* works of canonical modern playwrights like Cao Yu.

This tradition continues in the monumental theater works of Tian Han, which constitute the main performance case studies of Chapter 2. However, the transformation of context to the first decades of a new socialist nation shifted the significance of such details. Under the mandates of socialist construction, both the building of state-of-the-art theaters and the industrialization of artistic production became important symbols of the new nation and markers of its successful adoption of the Soviet model. The push to create with “quantity, speed, quality, and efficiency” during the Great Leap Forward further inspired Tian Han to mobilize past and present in the service of a socialist utopian future in *Guan Hanqing* and *Fantasia of the Ming*

Tombs Reservoir. However, in suggesting how the writing and performance of plays might be used as a tool for the production of socialist values and model citizens, these works also move a step closer to transforming the theater into technology of ideological reproduction.

It is this idea of the mass production of model citizens via the mass reproduction of theatrical performance that then drives the codification of the *yangbanxi* during the Cultural Revolution. Although only discussed in brief in the present version of this project, the combination of unattainable technical virtuosity—in both physical technique and stage technology—and the goal of making live performance reproducible on a grand scale in the *yangbanxi* make them an important limiting case for its overarching arguments. The technologization of theater during the Cultural Revolution also set the stage for subsequent developments in the 1980s, when the theater community reclaimed the agency of stage technology and acting bodies alike. The primary case study analyzed in Chapter 3, *The Red Nose* by Yao Yiwei, demonstrates how the *huaju* actor especially came to be redefined as a multimedial actor: a versatile performer who was neither trapped by conventionality nor subject to the discipline of revolutionary choreography, and who operated in concert with other stage elements—lighting, sound, scenery, and, eventually, projection and video. Looking at “little theater” more broadly, I argue that much work of the immediate post-Cultural Revolution period focuses on staging the messy reality of the creative process, rather than a seamless finished product, and thereby functions as a kind of anti-technology wherein art and artists resist the cooptation of the state ideological apparatus.

Finally, Chapter 4 brings us to the media- and technology-saturated 21st century, where an aesthetic of technological excess has overwhelmed much of the cultural production in the People’s Republic of China. Technology fever, which afflicts state and citizens alike,

incentivizes artists to incorporate ever-more spectacular multimedia displays into works of live performance. The resulting large-scale spectacles, represented by the 2008 Beijing Olympics Opening Ceremony and “real-scene performances” at tourist destinations throughout the country, privilege a mode of uncritical absorption that threatens to realize the worst fears of 20th-century technology critics. This mainstream mode, however, has been met with resistance by innovative and critically minded artists such as Wang Chong and Feng Jiangzhou. For these directors and others like them, fast-paced technological development galvanizes both their artistic practice, pushing them to experiment with daring combinations of live and mediated presence onstage, and their social interventions. Even as their work echoes or borrows directly from the techniques of excessive performance, the resulting content and form has the potential to push audiences to new levels of awareness and reflection on the state of contemporary society and art. Simultaneously, by acquiring fluency in a vocabulary of techniques *and* technology critique familiar to theater artists and audiences abroad, these Chinese artists create a space for themselves and their work on the cutting edges of a globalized world.

The examples discussed in the fourth chapter, along with the final two cases introduced by this conclusion, demonstrate that the questions regarding the entanglement of theater, technology, and politics raised throughout this dissertation remain relevant and continue to evolve in the present. Beyond this, the way in which *Victory and Peace* and *Model Play 2.0* engage with particular episodes from the history of theater and technology—the production and multimedial circulation of *Roar, China!*, the creation and recreation of the *yangbanxi*—suggest that even as technology develops and its applications become more sophisticated, there emerges a feedback loop wherein the theater returns to past moments of technological significance. These added layers of technological citation in some sense echo the longstanding practice of allusion in

the Chinese literary tradition—a nod of reference within a larger whole, as in *Victory and Peace*, or the borrowing of a title and theme to fashion an entirely new work, as in *Model Play 2.0*. We might also think of them as another form of metatheater, paralleling the rewriting of theater history in *Guan Hanqing* (Chapter 2) and the staging of creative process in *The Red Nose* (Chapter 3). However, the two productions move in opposite directions in terms of their self-awareness: in superficially drawing on a now-famous phrase and visual imagery, *Victory and Peace* perhaps unwittingly creates deeper resonances with theater history, whereas *Model Play 2.0* could seem to some overly conscious of its own place in an ongoing process of mediation and remediation.

This question of self-awareness and how these productions might be perceived leads to one of the main questions left unanswered at the conclusion of this dissertation: how do the audiences awash in large-scale projections or watching a camera watching the actors onstage react to these new media aesthetics and their interventions in politics, history, art, and everyday life? In some sense, today's audience are the digital natives to technologized performance; after all, as theater scholar Chiel Kattenbelt has observed, "...the expression 'all the world is a stage' is no longer just a metaphor, but a characteristic feature of our mediatized culture and society."⁵ Yet, nonetheless, theatrical performance still exists as a space and experience separate from the everyday; how might this broader acceptance of mediatized theatricality affect the relationship of audiences to the theater itself? What differences might there be between audiences of *Roar, China!* in 1933, awed by the novelty of the production's melding of stage technology and political message or enlightened by the "modern science" of lighting technology, and spectators of the 21st century? Or, what of theater patrons in the heady days of the young PRC, and rural

⁵ Chiel Kattenbelt, "Intermediality in Performance and as a Mode of Performativity," in *Mapping Intermediality in Performance*, 34-35.

audiences of technologically sophisticated *yangbanxi*? The analysis of this project has relied primarily on sources such as published reviews and responses to performances, when available, and by reading the ways in which technical documents attempt to script experience. However, its claims yet await the litmus test of different methodologies, such as oral history or audience surveys, which hopefully will enable us to more fully understand how the technology of modern Chinese theater has worked on its audiences and the worlds they have inhabited.

Another important question for future study centers on the economics of theatrical production in modern China. Throughout, this dissertation has hinted at the ways in which the apparatuses of commerce and exchange affect the theater; tickets for *Roar, China!* were given discounted to patrons of a particular store, for instance, while funding opportunities for international productions play into the calculations of contemporary theater artists. To delve into these connections and the others that undoubtedly lay just beneath the surface of the other case studies would move beyond the main focus and scope of this project in its present form, but remains essential to obtaining a more nuanced picture of the forces at work in establishing the close practical, artistic, and ideological linkages between theater and technology described herein. Moreover, given the fact that many of the most famous critiques of technology in the last century have centered on connections between technologies of mechanical reproduction or mass media, popular culture, and *capitalism*, further explorations in the economic contexts of Chinese socialism and post-socialism have the potential to contribute to more nuanced theorizations of some of the most important forces in the modern world.

Theater. Technology. Politics. As this dissertation has argued, these three terms together represent driving forces in the development of performance practice, artistic theory, and dramatic literature in modern China. The significance of their deep interrelation, however, reaches far

beyond the theater proper. Much more than mere technical detail, stage technologies have played an imperative role in the major projects of modern China: cultural reform, knowledge production, nation building, revolution. And as contemporary Chinese society becomes ever more suffused with media and technology—and perhaps ever more theatricalized as a result—the importance of understanding the evolving relationship between art, technology, and that world will only become more pressing.

Bibliography

Databases of Chinese Books and Periodicals

Airusheng Zhongguo jindai baokan ku 愛如生中國近代報刊庫 (ERUDITION Online Recent Newspapers and Periodicals Database) <http://server.wenzibase.com>

Dacheng laojiukan quanwen shujuku 大成老舊刊全文數據庫 (Dacheng Old Journal Database) <http://laokan.dachengdata.com>

Duxiu Zhongwen xueshu sousuo 讀秀中文學術搜索 (Duxiu Chinese Academic Search) www.duxiu.com

Guangming ribao tuwen dianziban 《光明日報》圖文電子版 <http://gmr.egreenapple.com>

Mingguo shiqi qikan quanwen shujuku 民国时期期刊全文数据库 (Shanghai Library Chinese Periodical Full-Text Database, 1911-1949) <http://www.cnbkcy.cn>

Zhonghua shuzi shuyuan 中華數字書苑 (Apabi China Digital Library) <http://www.apabi.com>

Zhongguo gaoxiao shuzihua tushuguan 中國高校數字化圖書館 (CADAL Digital Libraries, Zhejiang University) <http://www.cadal.zju.edu.cn>

Zhongguo xueshu qikan wang 中國學術期刊網 (CNKI China Academic Journals) <http://oversea.cnki.net>

Zhongwen jixian 中文集獻 (ChinaMAXX Digital Library) <http://chinamaxx.net>

Works Cited

Abel, Lionel. *Tragedy and Metatheatre: Essays on Dramatic Form*. New York: Holmes & Meier, 2003.

“*Ai bi si geng lengku ge boli erji xinxian xiju* 《愛比死更冷酷》隔玻璃帶耳機新鮮戲劇 (*Love is Colder than Death - Fresh Theater Separated by Glass and Wearing Headphones*).” *Sina Film Music and Entertainment*, November 8, 2008. <http://ent.sina.com.cn/j/p/2008-11-08/00432241268.shtml>.

Andrews, Julia Frances. *Painters and Politics in the People's Republic of China, 1949-1979*. Berkeley, CA: University of California Press, 1994.

Aoyun qingdian: Beijing aoyun huiyishi ji saishi zongshu 《奧運慶典：北京奧運會儀式及賽事總述》(Ceremonies and Competitions: Celebration of the Games). Beijing: Beijing tiyu daxue chubanshe, 2010.

Aronson, Arnold. *Looking into the Abyss: Essays on Scenography*. Ann Arbor: University of Michigan Press, 2005.

Auslander, Philip. "Liveness, Mediatization, and Intermedial Performance." *Degrés: Revue de Synthèse À Orientation Sémiologique* 101 (2000): 1–12.

———. *Liveness: Performance in a Mediatized Culture*. 2nd ed. New York: Routledge, 2008.

Bai, Ronnie. "Dances with Brecht: Huang Zuolin and His 'Xieyi' Theater." *Comparative Drama* 33, no. 3 (1999): 339–64.

Bao, Weihong. "The Art of Control: Hong Shen, Behavioral Psychology, and the Technics of Social Effects." *Modern Chinese Literature and Culture* 27, no. 2 (Fall 2015): 249–97.

———. *Fiery Cinema: The Emergence of an Affective Medium in China, 1915-1945*. Minneapolis, MN: University of Minnesota Press, 2015.

Barmé, Geremie. *In the Red: On Contemporary Chinese Culture*. New York: Columbia University Press, 1999.

Bay-Cheng, Sarah. *Mapping Intermediality in Performance*. MediaMatters. Amsterdam: Amsterdam University Press, 2010.

Beacham, Richard C. *Adolphe Appia: Texts on Theatre*. New York: Routledge, 1993.

"Beijing Conjures Olympic Opening Epic with High Technology." *Xinhua Net*, August 9, 2008. http://news.xinhuanet.com/english.2008-08/09/content_9067144.htm.

Beijing Renmin yishu juyuan yanchu juben xuan: 1952-2012 《北京人民藝術劇院演出劇本選：1952-2012》(Select Production Scripts from the Beijing People's Art Theater: 1952-2012). Vol. 2. Beijing: Beijing chubanshe, 2012.

Beijing renmin yishu juyuan yishu yanjiu ziliao bianjizu 北京人民藝術劇院《藝術研究資料》編輯組. *Cai Wenji de wutai yishu* 《〈蔡文姬〉的舞台藝術》(The Stage Art of Cai Wenji). Shanghai: Shanghai wenyi chubanshe, 1981.

———. ed. *Chaguan de wutai yishu* 《〈茶館〉的舞台藝術》(The Stage Art of Teahouse). Beijing: Zhongguo xiju chubanshe, 1980.

———. ed. *Longxugou de wutai yishu* 《〈龍鬚溝〉的舞台藝術》(The Stage Art of Dragon Beard Ditch). Beijing: Zhongguo xiju chubanshe, 1987.

———. ed. *Luotuo Xiangzi de wutai yishu* 《〈駱駝祥子〉的舞台藝術》(The Stage Art of Camel Xiangzi). Beijing: Zhongguo xiju chubanshe, 1982.

Beijing renyi dashiji bianjizu 北京人藝大事記編輯組, ed. *Beijing Renmin yishu juyuan dashiji* 《北京人民藝術劇院大事記》 (Beijing People's Art Theater Record of Major Events). Vol. 1, 1952-1956. Beijing: Beijing renmin yishu juyuan, 2008.

“Beijing shoudu juchang juxing kaimushi: Sulian ‘Xiaobaishu’ wudao tuan zuo biaoan 北京首都劇場舉行開幕式：蘇聯‘小白樺樹’舞蹈團作表演 (Opening Ceremony at the Capital Theater in Beijing: The Soviet 'Little White Birch' Dance Troupe Performs).” *Guangming ribao* 《光明日報》, November 6, 1955.

“Beijing Tianqiao juchang kaimu 北京天橋劇場開幕 (Beijing's Tianqiao Theater Opens).” *Guangming ribao* 《光明日報》, January 17, 1954.

Beijing tushuguan 北京图书馆 (Beijing Library). *Minguo shiqi zong shumu, 1911-1949* 《民國時期總書目, 1911-1949》 (Complege Bibliography of the Republican Era, 1911-1949). Vol. 15, *Wenhua, kexue, yishu* 文化, 科學, 藝術. Beijing: Shumu wenxian chubanshe, 1994.

Berry, Chris. “Every colour red? Colour in the films of the Cultural Revolution model stage works.” *Journal of Chinese Cinemas* 6, no. 3 (2012): 233–46.
———. “Getting Real: Chinese Documentary, Post-Socialism.” In *The Urban Generation: Chinese Cinema and Society at the Turn of the Twenty-First Century*, edited by Zhang Zhen, 115–34. Durham, NC: Duke University Press, 2007.

Bi Bo 碧波. “Kan Nuhouba, Zhongguo! zhi hou 看「怒吼吧，中國！」之後 (After Seeing *Roar, China!*).” *Shanhu* 《珊瑚》 3, no. 9 (1933): 6.

Bolter, J. David, and Richard A. Grusin. *Remediation: Understanding New Media*. Cambridge, MA: MIT Press, 1999.

Boyd, Mari. “From Ota Shogo’s ‘Earth Station’ to Wang Chong’s ‘e-Station.’” *TheatreForum - International Theatre Journal*, 2009, 66–72.

Braester, Yomi. *Painting the City Red: Chinese Cinema and the Urban Contract*. Asia-Pacific. Durham NC: Duke University Press, 2010.
———. *Witness against History: Literature, Film, and Public Discourse in Twentieth-Century China*. Stanford, Calif: Stanford University Press, 2003.

Bray, Francesca. “The Powers of Tu.” In *Graphics and Text in the Production of Technical Knowledge in China: The Warp and the Weft*, edited by Francesca Bray, Vera Dorofeeva-Lichtmann, and Georges Métaillie, 1–78. Sinica Leidensia, v. 79. Boston: Brill, 2007.

Brecht, Bertolt. “Interview with an Exile.” In *Brecht on Theater: The Development of an Aesthetic*, edited and translated by John Willet. London: Methuen Drama, 1964.
———. “Short Description of a New Technique of Acting Which Produces an Alienation Effect.” In *Brecht on Theater: The Development of an Aesthetic*, edited and translated by John Willet, 136–47. London: Methuen Drama, 1964.

———. “The Modern Theater Is the Epic Theater.” In *Brecht on Theater: The Development of an Aesthetic*, edited and translated by John Willet, 33-42. London: Methuen Drama, 1964.

Brockett, Oscar G. *History of the Theatre*. 7th edition. Boston: Allyn and Bacon, 1995.

Broudehoux, Anne-Marie. “Spectacular Beijing: The Conspicuous Construction of an Olympic Metropolis.” *Journal of Urban Affairs* 29, no. 4 (October 1, 2007): 383–99. doi:10.1111/j.1467-9906.2007.00352.x.

Cao Yu 曹禺. “Leiyu 雷雨 (Thunderstorm).” *Wenxue jikan* 《文學季刊》 1, no. 3 (1934): 119-244.

———. “Leiyu 《雷雨》 (Thunderstorm).” In *Cao Yu xiji ji* 《曹禺戲劇集》, Vol. 1. Beijing: Wenhua shenghuo chubanshe, 1936.

———. “Leiyu 《雷雨》 (Thunderstorm).” In *Cao Yu quanji* 《曹禺全集》, edited by Tian Benxiang 田本相 and Liu Yijun 劉一軍, 1:5–188. Shijiazhuang: Huashan wenyi chubanshe, 1996.

———. *Richu* 《日出》 (Sunrise). Shanghai: Wenhua shenghuo chubanshe, 1937.

———. “*Richu* ba 《日出》 跋 (Postscript to *Sunrise*).” In *Cao Yu quanji* 《曹禺全集》, edited by Tian Benxiang 田本相 and Liu Yijun 劉一軍, 380-397. Shijiazhuang: Huashan wenyi chubanshe, 1996.

———. “Thunderstorm.” In *The Columbia Anthology of Modern Chinese Drama*, edited by Xiaomei Chen, translated by Wang Tso-liang, A.C. Barnes, and Charles Qianzhi Wu, 157–282. New York: Columbia University Press, 2010.

Carlson, Marvin A. *Places of Performance: The Semiotics of Theatre Architecture*. Ithaca, NY: Cornell University Press, 1989.

Chansky, Dorothy. *Composing Ourselves: The Little Theatre Movement and the American Audience*. Theater in the Americas. Carbondale: Southern Illinois University Press, 2004.

Chapple, Freda, Chiel Kattenbelt, and International Federation for Theatre Research. Theatre and Intermediality Working Group. *Intermediality in Theatre and Performance*. Themes in Theatre ; 2. New York: Rodopi, 2006.

Chen Dabei 陳大悲. *Aimei de xiju* 《愛美的戲劇》 (Amateur Theater). Shanghai: Shanghai shudian, 1992.

Chen Dabei 陳大悲. *Xiju ABC* 《戲劇 ABC》 (ABC's of Theater) . Shanghai: Shijie shuju, 1931.

Cheng Yanqiu 程硯秋. “Huaju daoyan guankui 話劇導演管窺 (My Limited Knowledge of Spoken Drama Directing).” Transcribed by Liu Shouhe 劉守鶴. *Juxue yuekan* 《劇學月刊》 2, no. 7–8 (1933): 1–64.

Cheng Yuangong 成元功. "Guanxin Beijing chengshi jianshe 關心北京城市建設 (Regarding the Building of Beijing)." In *Zhou Enlai yu Beijing* 《周恩來與北京》. Beijing: Zhongyang chubanshe, 1998.

Chen Jide 陳吉德. *Zhongguo dangdai xianfeng xiju, 1979-2000* 《中國當代先鋒戲劇, 1979-2000》 (Contemporary Avant-garde Theatre in China). Beijing: Beijing xiju chubanshe, 2004.

Chen Jun 陳軍. *Xi ju wen xue yu ju yuan ju chang : yi "Guo, Lao, Cao" yu Beijing ren yi wei li* 《戲劇文學與劇院劇場：一郭，老，曹與北京人藝為例》 (Drama Literature and Theatre: Guo Moruo, Lao She, Cao Yu and Beijing People's Theatre as an Example). Beijing: Shehui kexue wenxian chubanshe, 2011.

Chen, Xiaomei. *Acting the Right Part: Political Theater and Popular Drama in Contemporary China*. Honolulu: University of Hawai'i Press, 2002. http://nrs.harvard.edu/urn-3:hul.ebookbatch.PMUSE_batch:muse9780824861360.

———. "A Stage in Search of a Tradition: The Dynamics of Form and Content in Post-Maoist Theatre." *Asian Theatre Journal* 18, no. 2 (2001): 200–221.

———. "A 'Wildman' Between Two Cultures: Some Paradigmatic Remarks on 'Influence Studies.'" *Comparative Literature Studies* 29, no. 4 (1992): 397.

———. *Occidentalism: A Theory of Counter-Discourse in Post-Mao China*. 2nd ed., rev. and expanded. Lanham, Md: Rowman & Littlefield, 2002.

Chen Yong. "Brecht and the Current Transformation of the Theatre in China." *The Brecht Yearbook* 14 (1989): 47.

———. "The Beijing Production of Life of Galileo." In *Brecht and East Asian Theatre: The Proceedings of a Conference on Brecht in East Asian Theatre*, edited by Antony Tatlow and Tak-Wai Wong, 88–95. Hong Kong: Hong Kong University Press, 1982.

Chen Yongxiang 陳永祥. "Leiyu de wutai huanjing 《雷雨》的舞台環境 (The Stage Environment of Thunderstorm)." In *Leiyu de wutai yishu* 《〈雷雨〉的舞台藝術》 (The Stage Art of Thunderstorm), edited by Su Min 蘇民 et al. Shanghai: Shanghai wenyi chubanshe, 1982.

Chen Yong 陳顥. "Daoyan gousi 導演構思 (Director's Concept)." In *Hong Bizi de wutai yishu* 《〈紅鼻子〉的舞台藝術》, edited by Lin Kehuan 林克欢, 3–30. Beijing: Zhongguo xiju chubanshe, 1984.

———. "Daoyan tanhua lu 導演談話錄 (Director's Notes)." In *Hong Bizi de wutai yishu* 《〈紅鼻子〉的舞台藝術》, edited by Lin Kehuan 林克欢, 31–52. Beijing: Zhongguo xiju chubanshe, 1984.

———. "Wei zaori shixian zuguo tongyi daye gongxian liliang—Hongbizi paiyan suibi 為早日實現祖國統一大業貢獻力量 (A Contribution to Unifying the Country--Notes on Rehearsing The Red Nose)." *Yingju meishu* 《影劇美術》 4 (1982): 2–3.

———. *Wode yishu wutai* 《我的藝術舞台》 (My Artistic Stage). Beijing: Zhongguo xiju chubanshe, 1999.

Chow, Rey. *Writing Diaspora: Tactics of Intervention in Contemporary Cultural Studies*. Arts and Politics of the Everyday. Bloomington, IN: Indiana University Press, 1993.

Chung, Mingder. "The Little Theatre Movement of Taiwan (1980-1989): In Search of Alternative Aesthetics and Politics." PhD Dissertation, New York University, 1992.

Clark, Paul. *The Chinese Cultural Revolution: A History*. Cambridge ; New York: Cambridge University Press, 2008.

Coderre, Laurence. "Breaking Bad: Sabotaging the Production of the Hero in the Amateur Performance of Yangbanxi." In *Listening to China's Cultural Revolution: Music, Politics, and Cultural Continuities*, edited by Paul Clark, Laikwan Pang, and Tsan-Huang Tsai. Chinese Literature and Culture in the World. New York: Palgrave Macmillan, 2015.

Conceison, Claire. "China's Experimental Mainstream: The Badass Theatre of Meng Jinghui." *TDR: The Drama Review* 58, no. 1 (2014): 64–88.
———. *Significant Other: Staging the American in China*. Honolulu: University of Hawai'i Press, 2004. http://nrs.harvard.edu/urn-3:hul.ebookbatch.PMUSE_batch:muse9780824864316.

Coulter, Todd J. *Transcultural Aesthetics in the Plays of Gao Xingjian*. First edition. Palgrave Pivot. New York, NY: Palgrave Macmillan, 2014.

Crane, Robert. "Between Factography and Ethnography: Sergei Tretyakov's Roar, China! And Soviet Orientalist Discourse." *Text & Presentation* 41 (2010): 41–53.

Davis, Darrell William. *Picturing Japaneseness: Monumental Style, National Identity, Japanese Film*. New York: Columbia University Press, 1996.

Denton, Kirk. "Model Drama as Myth: A Semiotic Analysis of Taking Tiger Mountain by Strategy." In *Drama in the People's Republic of China*, edited by Constantine Tung and Colin Mackerras. Albany: State University of New York Press, 1987.

Dixon, Steve. *Digital Performance: A History of New Media in Theater, Dance, Performance Art, and Installation*. Leonardo Books. Cambridge, Mass: MIT Press, 2007.

Dolby, William. *A History of Chinese Drama*. London: P. Elek, 1976.

Dolla, Varaprasad S. *Science and Technology in Contemporary China: Interrogating Policies and Progress*. Delhi, India: Cambridge University Press, 2015.

Dong Jian 董建. *Tian Han Zhuan 《田漢傳》* (Biography of Tian Han). Beijing: Beijing shiyue wenyi chubanshe, 1996.

Du Jinhua 杜晋華. "Huaju? Dianying? Geming? 話劇? 電影? 革命? (Spoken Drama? Film? Revolution?)." *Jingpin gouwu zhinan 《精品購物指南》*, July 19, 2012. <http://hanenaka.wix.com/theatre-du-reve#!20120719/coz3>.

Essin, Christin. *Stage Designers in Early Twentieth-Century America: Artists, Activists, Cultural Critics*. New York: Palgrave MacMillan, 2012.

Fan Feiyan 樊飛燕, and Han Shunfa 韓順法. "Xin meiti shidai wutai yishu de qipa--duomeiti xiju 新媒體時代舞台藝術的奇葩——多媒體戲劇 (Exotic Fruits of the Performing Arts in the New Media Age--Multimedia Theater)." *Wenhua yishu yanjiu* 《文化藝術研究》 5 (2009): 190–94.

Felton, Jim. "e-Station." *Nytheatre.com*, August 22, 2009. <http://www.nytheatre.com/Review/will-fulton-2009-8-22-e-Station>.

Felton-Dansky, Miriam. "Fringe Festival 2009 Reviews." *Village Voice*, August 11, 2009. <http://www.villagevoice.com/arts/fringe-festival-2009-reviews-7134486>.

Feng Fusheng 馮福生. "Rensheng de Mianju 人生的面具 (The Masks We Wear)." In *Hong Bizi de wutai yishu* 《〈紅鼻子〉的舞台藝術》, edited by Lin Kehuan 林克欢, 197–203. Beijing: Zhongguo xiju chubanshe, 1984.

Feng Jiangzhou 丰江舟. "Feng Jiangzhou: Shuzi yishu gai zenme wan 丰江舟：數字藝術該怎麼玩 (Feng Jiangzhou: How to Make Digital Art)." Interview by Wang Boqiao 王泊喬, April 2, 2009. <http://blog.artintern.net/article/38298>.

Ferrari, Rossella. "Architecture And/in Theatre from the Bauhaus to Hong Kong: Mathias Woo's Looking for Mies." *New Theatre Quarterly* 28, no. 1 (2012): 3–19.

———. "Performing Poetry on the Intermedial Stage: Flowers in the Mirror, Moon on the Water and Beijing Avant-Garde Theatre in the New Millennium." In *Staging China: New Theatres in the Twenty-First Century*, edited by Ruru Li, 123–40. Chinese Literature and Culture in the World. New York: Palgrave Macmillan, 2016.

———. *Pop Goes the Avant-Garde: Experimental Theatre in Contemporary China*. Enactments. London: Seagull, 2012.

———. "The Avant-Garde Is Dead, Long Live the (Pop) Avant-Garde! Critical Reconfigurations in Contemporary Chinese Theatre." *Positions: East Asia Cultures Critique* 20, no. 4 (2012): 1127–57.

———. "The Stage as a Drawing Board: Zuni Icosahedron's Architecture Is Art Festival." *TDR: The Drama Review* 55, no. 1 (2011): 137–49.

Fischer-Lichte, Erika, and Benjamin Wihstutz. *Performance and the Politics of Space: Theatre and Topology*. New York: Routledge, 2013.

Fokkema, Douwe Wessel. *Literary Doctrine in China and Soviet Influence, 1956-1960*. The Hague, Mouton, 1965.

Fong, Gilbert C.F. "Introduction." In *The Other Shore: Plays by Gao Xingjian*, edited and translated by Gilbert C.F. Fong, ix – xlii. Hong Kong: Chinese University of Hong Kong, 1999.

Fore, Devin. "Introduction to Special Issue on Soviet Factography." *October* 118 (Fall 2006): 3–10

Friedman, Alison. "A New Regime." *International Arts Manager* 10, no. 12 (December 2014): 37.

Fu Chenglan 傅成藍. "Huaju tuanli de zaji yanyuan 話劇團裡的'雜技演員' (Acrobats in a Spoken Drama Troupe)." *Renmin xiju* 《人民戲劇》 4 (1982): 20–21.

Fu Jin 傅謹. *Xin Zhongguo xi ju shi, 1949-2000* 《新中國戲劇史, 1949-2000》 (A History of Drama in New China, 1949-2000). Changsha: Hunan meishu chubanshe, 2002.

Gamsa, Mark. "Sergei Tret'iakov's Roar, China! Between Moscow and China." *Itinerario* 36, no. 2 (August 2012): 91–108.

Gao Xingjian 高行健. "Jinghua Yetan 京華夜談 (Evening Chats in Beijing)." In *Dui yizhong xiandai xiju de zhuiqiu* 《對一種現代戲劇的追求》 (In Pursuit of a Modern Theater), 152–241. Beijing: Zhongguo xiju chubanshe, 1988.

———. "Some Suggestions on Producing The Other Shore." In *The Other Shore: Plays*, edited and translated by Gilbert C.F. Fong. Hong Kong: Chinese University of Hong Kong, 1999.

———. "Wode Xiju He Wode Yaoshi 我的戲劇和我的鑰匙 (My Theater and My Key)." In *Meiyou Zhuyi* 《沒有主義》 (Without Isms), 235–52. Hong Kong: Cosmos Books, 2000.

Ge Fei 葛飛. "Nubouba Zhongguo! yu 1930 niandai zhengzhi xuanchuan ju 《怒吼吧，中國！》與 1930 年代政治宣傳劇 (*Roar, China!* and Political Propaganda Drama of the 1930s)." *Yishu pinglun* 《藝術評論》 10 (2008): 23–28.

Goldman, Andrea S. *Opera and the City: The Politics of Culture in Beijing, 1770-1900*. Stanford, CA: Stanford University Press, 2012.

Goldstein, Joshua. *Drama Kings: Players and Publics in the Re-Creation of Peking Opera, 1870-1937*. Berkeley, CA: University of California Press, 2007. http://nrs.harvard.edu/urn-3:hul.ebookbatch.PMUSE_batch:PMUSE193420150515.

Gong Hede 龔和德. *Wutai meishu yanjiu* 《舞台美術研究》 (Stage Art Research). Beijing: Zhongguo xiju chubanshe, 1987.

Grotowski, Jerzy. *Towards a Poor Theatre*. New York, Simon and Schuster, 1968.

———. (Yeshe Geluotoufusiji 耶士·格洛托夫斯基) *Maixiang zhipu* 《邁向質樸戲劇》 (Towards a Poor Theater). Translated by Wei Shi 魏時. Beijing: Zhongguo xiju chubanshe, 1984.

———. "Puzhi xiju yu leixiju lilun xuan yi '質樸戲劇' 與 '類戲劇' 理論選擇 (Select Translations of 'Poor Theater' and 'Paratheater' Theory)." Translated by Mao Baiyu 矛百玉. *Xiju yishu* 《戲劇藝術》 4 (1982): 91–101.

———. “Xiju de xinyue 戲劇的新約 (A New Testament for Theater).” *Waiguo xiju* 《外國戲劇》 4 (1980).

———. (Geluotouofusiji 格洛托夫斯基). “Yanyuan jibengong xunlian 演員基本功訓練 (Foundational Training for Actors).” Translated by Danni 丹尼 and Huang Haiqin 黃海芹. *Xiju yishu* 《戲劇藝術》 4 (1981): 7–20.

Guan, Datong. *The Socialist Transformation of Capitalist Industry and Commerce in China*. China Knowledge Series. Peking: Foreign Languages Press, 1960.

Guan Hanqing 《關漢卿》 (Guan Hanqing). Directed by Xu Tao 徐韜. 1960. Guangzhou: Qiaojiaren wenhua chuanbo gongsi, 1997. VCD.

“*Guan Hanqing daoyan, sheji tan wutai meishu* 《關漢卿》導演，設計談舞臺美術 (Guan Hanqing Director and Set Designer Discussions on Scenography),” nos. 1-14. February 5, 1963–July 23, 1963. BPAT Theater Museum Archive.

“*Guan Hanqing yanchu ben* 《關漢卿演出本》 (Guan Hanqing Production Script),” 1963. BPAT Theater Museum Archive.

Guan Hanqing 關漢卿. *Guan Hanqing xi qu ji* 《關漢卿戲曲集》 (Collected *Xiqu* Works of Guan Hanqing). Edited by Wu Hsiao-ling 吳曉鈴. Beijing: Zhongguo xiju chubanshe, 1958.

“Guanyu Yinxiang 關於印象 (About Impression).” *Guan Yinxiang*. Accessed October 10, 2015. <http://www.guanyinxiang.com/about.html>.

Gu Chunfang 顧春芳. *Tade wutai: Zhongguo xiju nü daoyan chuanguo yanjiu* 《她的舞台：中國戲劇女導演創作研究》 (Her Stage: A Study of the Creative Work of Female Chinese Directors). Shanghai: Yuandong chubanshe, 2011.

Guoli xiju xueyuan yilan 《國立戲劇學校一覽》 (A General Survey of the National Theater Academy). Nanjing: Guoli xiju xueyuan, 1935.

Guo Moruo 郭沫若, and Tian Han 田漢, “Guanyu *Guan Hanqing* de tongxin 關於‘關漢卿’的通信 (Letter about *Guan Hanqing*).” *Juben* 《劇本》 5 (1958): 9-11.

Guo Rongchen 郭榮忱. “Dengguang sheji de yixie shexiang 燈光設計的一些設想 (A Few Ideas on Lighting Design).” In *Hong Bizi de wutai yishu* 《〈紅鼻子〉的舞台藝術》, edited by Lin Kehuan 林克欢, 255–58. Beijing: Zhongguo xiju chubanshe, 1984.

Han Sheng 韓生, ed. *Shanghai shi duomeiti yanyi xuni kongjian hecheng zhongdian shiyanshi: shuzi yanchu yishu chuanguo shiyan* 《上海市多媒體演藝虛擬空間和成重點實驗室：數字演出藝術創作實驗》 (Shanghai Virtual Performance Art Lab: Experiments in Digital Arts Performance). Shanghai: Shanghai wenyi chubanshe, 2012.

Harris, Kristine. "Re-makes/Re-Models: The Red Detachment of Women between Stage and Screen." *The Opera Quarterly* 26, no. 2–3 (2010): 316–42. doi:10.1093/oq/kbq015.

Heidegger, Martin. "The Question Concerning Technology," *Basic Writings*, edited and translated by David Farrell Krell, 287–317. New York: Harper Perennial, 2008.

He Mengfu 賀孟斧. *Wutai zhaoming* 《舞台照明》 (Stage Illumination). Shanghai: Shangwu yinshua guan, 1936.

Ibsen, Henrik. "Ghosts." In *Henrik Ibsen: Four Major Plays*, translated by James McFarlane and Jens Arup, 89–164. Oxford, UK: Oxford University Press, 2008.

He Pu 何璞. "Duomeiti zai xijuzhong de chuanyi biao xian 多媒體在戲劇中的創意表現." *Yunnan yishu xueyuan xuebao* 《雲南藝術學院學報》 4 (2010): 60–64.

Hockx, Michel. *Questions of Style: Literary Societies and Literary Journals, 1911–1937*. Leiden: Brill, 2003.

Hong Hong 洪宏. "Shi xiju zou xiang molu haishi xueli wuruqitu? Ye tan suowei dangdai xiju de zhongjie 是戲劇走向末路還是學理誤入歧途？也談所謂當代戲劇的‘終結.’ (The End of the Pass for Theater or a Misunderstanding? Further Thoughts on the 'End' of Contemporary Theater)." *Wenyi zhengming* 《文藝爭鳴》 6 (2005): 115–18.

Hosokawa, Shuhei. "The Walkman Effect *." *Popular Music* 4 (1984): 165–80. doi:10.1017/S0261143000006218.

Hsia, Adrian. "The 'Brechtian' Drama of Sha Yexin." *Comparative Literature Studies* 30, no. 4 (1993): 405.

Huang, Alexander C. Y. *Chinese Shakespeares: Two Centuries of Cultural Exchange*. New York: Columbia University Press, 2009.

Huang Cun 黃村. "Wutai xiaoguo san (lei, dian) 舞台效果三（雷，電）." *Zongyi* 《綜藝》，1948, 5.

Huang, Hao. "Voices from Chinese Rock, Past and Present Tense: Social Commentary and Construction of Identity in Yaogun Yinyue, from Tiananmen to the Present." *Popular Music and Society* 26, no. 2 (2003): 183–202. doi:10.1080/0300776032000095512.

———. "'Yaogun Yinyue': Rethinking Mainland Chinese Rock 'N' Roll." *Popular Music* 20, no. 1 (2001): 1–11.

Huang Huang 黃惶. "Dengguang de yanyong 燈光的御用." *Minzu wenyi yuekan* 《民族文藝月刊》 1, no. 3 (1937): 12–14.

Huang Zaimin 黃在敏. “Yifen baogui de yishu cailiao--jieshao *Chaguan de wutai yishu* 一份寶貴的藝術財富——介紹《〈茶館〉的舞台藝術》一書 (A Valuable Arts Resource--Introducing The Stage Art of Teahouse).” In *Zhongguo xiju nianjian 1981* 《中國戲劇年鑑 1981》, 240–41. Beijing: Zhongguo xiju chubanshe, 1981.

Huang Zuolin 黃佐鄰. “Shenme jiao ‘qionggan xiju’ 什麼叫‘窮干戲劇 (What is 'Poor Theater')?’” *Waiguo xiju* 《外國戲劇》 1 (1982): 52–53.

Hung, Chang-tai. *Mao's New World: Political Culture in the Early People's Republic*. Ithaca, NY: Cornell University Press, 2011.

———. “Mao's Parades: State Spectacles in China in the 1950s” 190 (2007): 411–31.

Hu Xiang 胡祥. “Yong dianying de fangshi pai yi bu xiju 用電影的方式拍一部戲劇 (Using Cinematic Techniques to Put on a Play).” *Beijing qingnian bao* 《北京青年報》. July 17, 2012. <http://hanenaka.wixsite.com/theatre-du-reve/20120717>.

Hu Xingliang 胡星亮. *Xiandai xiju yu xiandai xing* 《現代戲劇與現代性》. Beijing: Renmin wenzue chubanshe, 1994.

Idema, Wilt L. “Performances on a Three-tiered Stage: Court Theatre During the Qianlong Era.” In *Ad Seres et Tungusos: Festschrift für Martin Gimm zu seinem 65. Geburtstag am 25. Mai 1995*, edited by Martin Gimm, Lutz Bieg, Erling von Mende, and Martina Siebert, 201–19. Opera sinologica, 11. Wiesbaden: Harrassowitz, 2000.

———. *The Dramatic Oeuvre of Chu Yu-Tun (1379-1439)*. Sinica Leidensia; v. 16. Leiden: EJBrill, 1985.

Idema, Wilt L., and Stephen H. West. *Chinese Theater, 1100-1450: A Source Book*. Münchener Ostasiatische Studien; Bd. 27. Wiesbaden: Steiner, 1982.

Iwaki Kyoko 岩城京子. “(評舞台) 薪伝実験劇団「ゴースト 2.0」 現代中国を覆う「嘘くささ。」” *Asahi Shinbun* 《朝日新聞》 November 27, 2014. <http://hanenaka.wixsite.com/theatre-du-reve/20141127j>.

Jiang, Jiehong. *Burden or Legacy: From the Chinese Cultural Revolution to Contemporary Art*. Hong Kong: Hong Kong University Press, 2007.

Jiang Qing. “On the Revolution in Peking Opera (Tan Jingju Geming).” Translated by Jessica Ka Yee Chan. *The Opera Quarterly* 26, no. 2–3 (2010): 455–59. doi:10.1093/oq/kbq025.

Jiang Rui 蔣瑞 and Zhang Fan 張帆. “Chong pai *Guan Hanqing* tishi sanji 重排《關漢卿》提示散記 (Brief Notes on Restaging Guan Hanqing).” In *Jiao Juyin wenji* 《焦菊隱文集》, 4:320–21. Beijing: Wenhua yishu chubanshe, 1988.

Jiao Juyin 焦菊隱. *Daoyan de yishu chuangzao* 《導演的藝術創造》. Beijing: Wenhua shenghuo chubanshe, 1953.

———. *Jia Juyin xiju lunwenji* 《焦菊隱戲劇論文集》. Shanghai: Shanghai wenyi chubanshe, 1979.

———. *Jiao Juyin wenji* 《焦菊隱文集》. Beijing: Wenhua yishu chubanshe, 1988.

———. “Wutai deng chujiang 舞台燈初講 (A Preliminary Discussion of Stage Lighting).” *Juxue yuekan* 《劇學月刊》 2, no. 7–8 (August 1933): 5–6.

Jin Shan 金山. “Huiyi Lanyi jushe 回憶藍衣劇社.” In *Zhongguo huaju yundong wushinian shiliao ji* 《中國話劇運動五十年史料集》, edited by Tian Han 田漢, 1:166–77. Beijing: Zhongguo xiju chubanshe, 1958.

Jin Shan 金山, Deng Zhiyi 鄧止怡, Jiang Xianglin 姜相麟, and Wu Xue 吳雪. *Shisanling shuiku changxiangqu* 十三陵水库畅想曲 (Fantasia of the Ming Tombs Reservoir). Beijing/Guangzhou: Zhongying yingxiang chuabnshe, 2005.

Jin Zhishun 金志舜. “Jianshe zhong de Guojia dajuyuan 建設中的國家大劇院 (Under Construction: The National Center for the Performing Arts).” *Yanyi keji* 《演藝科技》 1 (2004): 9–11.

“Jiu cheng guanzhong renke chuangxinban *Leiyu* 九成觀眾認可創新版《雷雨》.” *Xin Jing Bao* 《新京報》, July 23, 2012.

Jones, Andrew. *Yellow Music: Media Culture and Modernity in the Chinese Jazz Age*. Durham, NC: Duke University Press, 2001.

Judd, Ellen. “Prescriptive Dramatic Theory of the Cultural Revolution,” In *Drama in the People’s Republic of China*, edited by Constantine Tung and Colin Mackerras, 94–118. Albany: State University of New York Press, 1987.

Kaplan, Randy Barbara. “Planting the Seeds of Theatrical Realism in China: Tian Han’s Contributions to Modern Chinese Drama, 1920-1929.” *World Literature Today* 62, no. 1 (Winter 1988): 55–61.

King, Richard, Ralph C. Croizier, Sheng Tian Zheng, and Scott Watson. *Art in Turmoil: The Chinese Cultural Revolution, 1966-76*. Hong Kong: Hong Kong University Press, 2010.

Klich, Rosemary, and Edward Scheer. *Multimedia Performance*. New York: Palgrave Macmillan, 2012.

Kloet, Jeroen de. *China with a Cut: Globalisation, Urban Youth and Popular Music*. Amsterdam: Amsterdam University Press, 2010.

———. “Cosmopatriot Contaminations.” In *Cosmopatriots: On Distant Belongings and Close Encounters*, edited by Edwin Jurriëns, 133–54. Amsterdam: Rodopi, 2007.

Kong, Lily, and Justin O’Connor. *Creative Economies, Creative Cities: Asian-European Perspectives*. Dordrecht: Springer Netherlands, 2009.

Kuai Dashen 蒯大申 and Rao Xianlai 饒先來. *Xin Zhongguo wenhua guanli tizhi yanjiu* 《新中國文化管理體制研究》 (A Study of the Cultural Administration System in New China). Shanghai: Shanghai renmin chubanshe, 2010.

Łabędzka, Izabella. *Gao Xingjian's Idea of Theatre: From the Word to the Image*. Sinica Leidensia ; v. 87. Leiden ; Boston: Brill, 2008.

Lan, Hua R., and Vanessa L. Fong. *Women in Republican China: A Sourcebook*. Armonk, NY: M.E. Sharpe, 1999.

Lau, Joseph S. M. *Ts'ao Yü, the Reluctant Disciple of Chekhov and O'Neill a Study in Literary Influence*. Hong Kong, China: Hong Kong University Press, 1970.

Lehmann, Hans-Thies. *Postdramatic Theatre*. Translated by Karen Jürs-Munby. New York: Routledge, 2006.

Lenin, Vladimir Il'ich. "Party Organization and Party Literature." In *Collected Works of V.I. Lenin*, 10:44–49. Moscow: Progress Publishers, 1965. <http://www.marxists.org/archive/lenin/works/1905/nov/13.htm>.

Leo, Lee. *Shanghai Modern: The Flowering of a New Urban Culture in China, 1930-1945*. Cambridge, MA: Harvard University Press, 1999.

Liang Qichao. "On the Relationship between Fiction and the Government of the People." In *Modern Chinese Literary Thought: Writings on Literature, 1893-1945*, edited and translated by Kirk Denton, 76–81. Stanford, CA: Stanford University Press, 1996.

Liang Shuang 梁爽. "Feng Jiangzhou: Dianzi Meiti de 'Luodi' Shiyan 丰江舟: 電子媒體的'落地'實驗 (Feng Jiangzhou: Electronic Media 'Touching the Ground' Experiments)." *Dongfang yishu* 《東方藝術》 7 (2009): 79–81.

Liao Ben 廖奔. *Zhongguo gu dai ju chang shi* 《中國古代劇場史》 (A History of Ancient Chinese Stages). Zhengzhou: Zhongzhou guji chubanshe, 1997.

Liao Danlin. "New 'Take' on Ibsen." *Global Times*, October 9, 2013. <http://www.globaltimes.cn/content/816612.shtml>.

Li Chang 李暢. "Wutai meishu duoyuanhua 舞台美術的多樣化 (The Diversification of Scenography)." In *Zhongguo xiju nianjian 1982* 《中國戲劇年鑑 1982》 (Chinese Theater Yearbook 1982), edited by Zhongguo xiju nianjian bianji bu 中國戲劇年鑑編輯部. Beijing: Zhongguo xiju chubanshe, 1982.

———. "Xuexi jiejian Ouzhou xianjin de wutai meishu gongzuo 學習借鑑歐洲先進的舞台美術工作 (Learning and Borrowing from Recent Work in European Scenography)." In *Dang women zaici xiangju: Zhongguo qingnian wengongtuan chufang 9 guo yinian ji* 《當我們再次

相聚: 中國青年文工團出訪 9 國一年記》(When We Meet Again: Memories of the China Youth Arts Troupe Touring 9 Countries in One Year), edited by Shi Yajuan 石雅娟, 108–11. Beijing: Wenhua yishu chubanshe, 2004.

———. “Zhongguo jindai huaju wutai meishu piantan--cong Chunliu dao wu Chongqing de wutai meishu 中國近代話劇舞台美術片談——從春柳社到霧重慶的舞台美術 (Talks on Scenography in Modern Chinese Spoken Drama--Scenography from Spring Willow Society to Foggy Chongqing.” In *Zhongguo huaju shiliao ji* 《中國話劇史料集》(Historical Materials of Chinese Spoken Drama), edited by Zhongguo yishu yanjiuyuan huaju yanjiusuo 中國藝術研究院話劇研究所, 252–308. Beijing: Wenhua yishu chubanshe, 1987.

Li Chang 李暢 et al. *Juchang yu wutai jishu* 《劇場與舞台技術》(Theaters and Stage Technology). Wuhan: Zhongnan renmin wenzue yishu chubanshe, 1954.

Li Ke 里克. “Hong bizi ji qi zuozhe Yao Yiwei 《紅鼻子》及其作者姚一葦 (The Red Nose and Its Author Yao Yiwei).” *Renmin ribao* 《人民日報》, March 7, 1982.

Lin Kehuan 林克欢, ed. *Hong Bizi de wutai yishu* 《〈紅鼻子〉的舞台藝術》. Beijing: Zhongguo xiju chubanshe, 1984.

———. “Yanyuan yu guanzhong 演員與觀眾.” In *Xijuguan zhengming ji* 《戲劇觀爭鳴集》. Beijing: Zhongguo xiju chubanshe, 1986.

———. “Yao Yiwei he tade *Hongbizi* 姚一葦和他的《紅鼻子》(Yao Yiwei and His *Red Nose*).” In *Hong Bizi de wutai yishu* 《〈紅鼻子〉的舞台藝術》, edited by Lin Kehuan 林克欢, 272–73. Beijing: Zhongguo xiju chubanshe, 1984.

———. “Yao Yiwei xiansheng he tade *Hongbizi* 姚一葦先生和他的《紅鼻子》(Yao Yiwei and His *Red Nose*).” *Juben* 《劇本》 2 (1982): 82–84.

Li, Ruru. *The Soul of Beijing Opera: Theatrical Creativity and Continuity in the Changing World*. Hong Kong: Hong Kong University Press, 2010.

Li Song 李松, ed. *Yangbanxi biannian shi houbian* 《「樣板戲」編年史》後篇》(A Chronicle of Model Opera of Chinese Cultural Revolution Volume II). Taipei: Xiuwei zixun keji, 2012.

Lipfert, David. “A CurtainUp Report: 2009 New York International Fringe Festival.” *CurtainUp*, August 31, 2009. <http://www.curtainup.com/fringe09.html>.

Liu Juncan 劉君燦. “Zhongguo chuantong jishu sixiang yu xifang sixiang de duizhao 中國傳統技術思想與西方思想的對照 (A Comparison between Ancient Chinese Technological Thoughts and Western Ones).” *Kexue Yuekan* 《科學月刊》 320 (August 1996): 686–90.

Liu Liexiong 劉烈雄. *Zhongguo Shida xiju daoyan dashi* 《中國十大戲劇導演大師》(Ten Great Masters of Chinese Drama). Beijing: Zhongguo renmin daxue chubanshe, 2005.

Liu, Siyuan. *Performing Hybridity in Colonial-Modern China*. New York: Palgrave Macmillan, 2013.

Liu Zhifen 劉芷芬, Yao Jiaozheng 姚家征, Fan Yisong 范益松, Ding Gennan 丁根南, and Xu Zhong 徐忠. “Huaju yanyuan xingti xunlian: (er) wutai jineng 話劇演員形體訓練: (二) 舞台技能 (Physical Training for Spoken Drama Actors: (2) Stage techniques.” *Xiju yishu* 《戲劇藝術》 1 (1979): 100–102.

———. “Huaju yanyuan xingti xunlian: xuyan 話劇演員形體訓練: 序言 (Physical Training for Spoken Drama Actors: Preface).” *Xiju yishu* 《戲劇藝術》 2 (1978): 52–57.

———. “Huaju yanyuan xingti xunlian: xu 話劇演員形體訓練: 續 (Physical Training for Spoken Drama Actors: Continued).” *Xiju yishu* 《戲劇藝術》 2 (1979): 106–9.

———. “Huaju yanyuan xingti xunlian: (yi) jigong 話劇演員形體訓練: (一) 基本功 (Physical Training for Spoken Drama Actors: (1) Basics).” *Xiju yishu* 《戲劇藝術》 3 (1978): 51–65.

Li Weixin 李維新, Zeng Bangyu 鄭邦玉, Li Yonggui 李永貴, and Zhou Liguó 周立國. “Yuanzi yu aiqing 《原子與愛情》 (Atomic Love).” *Juben* 《劇本》 4 (1980): 4–37.

Li, Wuwei. *How Creativity Is Changing China*. New York: Bloomsbury Academic, 2011.

Li Xiao 李曉, ed. *Shanghai xiju zhi* 《上海話劇志》 (Shanghai Theater Gazetteer). Shanghai: Baijia chubanshe, 2002.

Li Yinan. “The Physical Body on the Grass Stage.” In *The Body at Stake: Experiments in Chinese Contemporary Art and Theatre*, edited by Jörg Huber and Zhao Chuan, 113–19. Bielefeld: Transcript, 2013.

Li Yutian 李玉田. “Guanyu batuo xiju weiji zhi yujian 關於擺脫戲劇危機之愚見 (My Humble Opinion on Escaping the Theater Crisis).” *Zhongguo xiju* 《中國戲劇》, no. 9 (2003): 8–9.

Li Zhiyan 黎之彥. “Tian Han chuanguo Guan Hanqing ceji 田漢創作《關漢卿》側記 (Notes on Tian Han’s Composition of Guan Hanqing).” *Xiju luncong* 《戲劇論叢》 1 (1982): 143–54.

———. “Tian Han zatan guancha shenghuo he xiju jiqiao: xiju chuanguo mantan zhi yi 田漢雜談觀察生活和戲劇技巧: 戲劇創作漫談之一 (Tian Han on Observing Life and Dramaturgy: Talks on Dramatic Creation No. 1).” *Juben* 《劇本》 7 (1959): 37–39.

Liu, Ping. “The Left-Wing Drama Movement in China and Its Relationship to Japan.” Translated by Krista Van Fleit Hang. *Positions* 14, no. 1 (Fall 2006): 449–66.

“Looking for Courage Produced by OperaNord, Copenhagen & Sifenlv New Media Studio, Beijing.” *Kobenhavens Internationale Teater*, n.d. http://www.kit.dk/2015/uk-OPERA_NORD.html.

Lu Fu 呂復, and Wang Yongde 王永德. “Zhongguo zuoyi xijujia lianmeng jianjie 中國左翼戲劇家聯盟簡介 (Brief Introduction to the Chinese League of Left-Wing Dramatists).” In *Zhongguo zuoyi xijujia lianmeng shiliao ji* 《中國左翼戲劇家聯盟史料集》, edited by

Wenhua bu dangshi ziliao zhengji gongzuo weiyuanhui 文化部黨史資料征集工作委員會.
Beijing: Zhongguo xiju chubanshe, 1991.

Luk, Thomas Y. T. "From Brecht, Artaud, and the Absurd to Sha Yexin and Gao Xingjian: Two Cases of *Rapport de Fait*." *Comparative Literature Studies* 48, no. 1 (2011): 64–81.
doi:10.5325/complitstudies.48.1.0064.

Luo, Liang. *The Avant-Garde and the Popular in Modern China: Tian Han and the Intersection of Performance and Politics*. Ann Arbor: University of Michigan Press, 2014.

Lu Shiwei 盧世偉. "Meng Jinghui VS Feng Jiangzhou: Women yaode jiushi bu anquan 孟京輝 VS 丰江舟‘我們要的就是不安全 (Meng Jinghui vs. Feng Jiangzhou: What We Want is Insecurity).'" *Sohu Entertainment*, March 7, 2007. <http://yule.sohu.com/20070330/n249095375.shtml>.

Lu Xiangdong 卢向东. *Zhongguo xiandai juchang de yanjin - Cong da wutai dao da juyuan* 《中國現代劇場的演進——從大舞台到大劇院》 (On the Evolution of Modern Theaters in China – a History from Grand Stage to Grand Theater). Beijing: Zhongguo jianzhu gongye chubanshe, 2009.

Lu Xun 魯迅. "Nala zouhou zeyang? 娜拉走後怎樣? (What Happens after Nora Leaves?)." In *Lu Xun quanji* 《魯迅全集》 1:160. Beijing: Renmin wenzue chubanshe, 2005.

MacFarquhar, Roderick. *The Origins of the Cultural Revolution*. New York: Columbia University Press, 1974.

Mackay, Constance D'Arcy. *The Little Theatre in the United States*. New York: H. Holt and Company, 1917.

Mackerras, Colin. *Amateur Theatre in China 1949-1966*. Contemporary China Papers, No. 5. Canberra, Australian National University Press, 1973.

———. "Modernization and Contemporary Chinese Theatre: Commercialization and Professionalization." In *Drama in the People's Republic of China*, edited by Constantine Tung and Colin Mackerras, 181–212. Albany: State University of New York Press, 1987.

———. *The Chinese Theatre in Modern Times: From 1840 to the Present Day*. Chinese History and Society. London: Thames and Hudson, 1975.

———. *The Rise of the Peking Opera, 1770-1870: Social Aspects of the Theatre in Manchu China*, Oxford, Clarendon Press, 1972.

Ma Junshan 馬俊山. "Yanju zhiyehua yundong yu huaju wutai yishu de zhengtihuwa 演劇職業化運動與話劇舞台藝術的整體化 (The Theater Professionalization Movement and the Coherence of Spoken Drama Scenography)." *Wenyi zhengming* 《文藝爭鳴》, no. 4 (2004): 45–52.

———. "Yanju zhiyehua yundong yu Zhongguo huaju wutai meishu de chengshou 演劇職業化運動與中國話劇舞台美術的成熟 (The Theater Professionalization Movement and the

Maturation of of Spoken Drama Scenography.” *Shanghai xiju xueyuan xuebao* 《上海戲劇學院學報》 4 (2005): 44-55.

Mao Jingang 毛金鋼. “Yanchu xingshi tezheng de tansuo--wutai meishu sheji tihui 演出形式特徵的探索——舞台美術設計體會 (Explorations in the Special Characteristics of Performance--Experiences in Scenic Design).” In *Hong bizi de wutai yishu* 《〈紅鼻子〉的舞台藝術》, edited by Lin Kehuan 林克欢, 251–54. Beijing: Zhongguo xiju chubanshe, 1984.

Mao Zedong 毛澤東. *Mao Zedong wenji* 《毛澤東文集》. Vol. 7. Beijing: Renmin chubanshe, 1999.

———. “On New Democracy,” 1940. http://www.marxists.org/reference/archive/mao/selected-works/volume-2/mswv2_26.htm#bm1.

———. “Talks at the Yan’an Forum on Literature and the Arts.” In *Selected Works of Mao Tse-Tung*, English ed. Vol. 3. Beijing: Foreign Languages Press, 1968.

https://www.marxists.org/reference/archive/mao/selected-works/volume-3/mswv3_08.htm.

Marx, Leo. “Technology: The Emergence of a Hazardous Concept.” *Technology and Culture* 51, no. 3 (2010): 561–77. doi:10.1353/tech.2010.0009.

Ma Ye 馬也. “Dangdai xiju mingyun zhi duanxiang 當代戲劇命運之斷想 (Scattered Thoughts on the Fate of Contemporary Theater).” *Zhongguo xiju* 《中國戲劇》 6 (2003): 8–12.

Ma Yuchao 馬昱超, Wei Jie 魏捷, and Cao Xiaolei 曹小磊. “E’meng chuxing--duomeiti xiju *Tianhua yu regou* 噩夢初醒——多媒體戲劇《天花與熱狗》 (Waking from a Nightmare--the Multimedia Play *Roadmetal Sweetbread*.” *Wenhua yuekan* 《文化月刊》 4 (2001): 62–65.

Mazzilli, Mary. *Gao Xingjian’s Post-Exile Plays: Transnationalism and Postdramatic Theatre*. New York: Bloomsbury Methuen Drama, 2015.

McDougall, Bonnie S. *The Literature of China in the Twentieth Century*. New York: Columbia University Press, 1997.

McGrath, Jason. “Cultural Revolution Model Opera Films and the Realist Tradition in Chinese Cinema.” *The Opera Quarterly* 26, no. 2 (2010): 343–76.

McLuhan, Marshall. *Understanding Media: The Extensions of Man*. 1st MIT Press ed. Cambridge, Mass: MIT Press, 1994.

Meserve, Ruth, and Walter Meserve. “The Stage History of *Roar, China!*: Documentary Drama as Propaganda.” *Theatre Survey* 21, no. 1 (May 1980): 1–13.

Metzger, Sean. “Ice Queens, Rice Queens, and Intercultural Investments in Zhang Yimou’s *Turandot*.” *Asian Theatre Journal* 20, no. 2 (2003): 209–17.

- Mumford, Lewis. *Technics and Civilization*. University of Chicago Press ed. Chicago: University of Chicago Press, 2010.
- Needham, Joseph. *Science and Civilisation in China*. Vol. 4.1. 7 vols. Cambridge, UK: University Press, 1954.
- Newhouse, Victoria. *Site and Sound: The Architecture and Acoustics of New Opera Houses and Concert Halls*. New York: Monacelli Press, 2012.
- Ni yi 尼一. “Wutai dengguang lüetan 舞台燈光略談 (A Brief Discussion of Stage Lighting).” *Xiandai xiju* 《現代戲劇》 2, no. 2 (1929): 112.
- “Nufang Shanghai Zhan Wutai Sheji Tubaoguang, Chenda Caimu Chengwei Liangdian.” Tencent Entertainment (Tengxun Yule 騰訊娛樂), November 10, 2010. <http://ent.qq.com/a/20101110/000020.htm>.
- Odom, Glenn. “Socialist Realism and New Subjectivities: Modern Acting in Gao Xingjian’s Cold Theatre.” *Asian Theatre Journal* 31, no. 1 (2014): 153–78.
- Osborne, Elizabeth A., and Christine Woodworth. *Working in the Wings: New Perspectives on Theatre History and Labor*. Carbondale: Southern Illinois University Press, 2015, 2015.
- Ouyang Luohan 歐陽勞汗. *Wutai meishu sheji gaishuo* 《舞台美術設計該說》 (On Scenic Design). Guiyang: Guizhou renmin chubanshe, 1984.
- Ouyang Shanzun 歐陽山尊. “Dianqi jian: zui jiandan de 'dimmer' de zuofa 電氣間：最簡單的'dimmer'的作法 (Dimmers: The Simplest Method).” *Xi* 《戲》 1, no. 1 (1933): 40–43.
- Ouyang Yuqian 歐陽予倩. “Nuhouba Zhongguo zai Guangdong shangyan ji 《怒吼罷中國》在廣東上演記 (A Record of the Performance of *Roar, China* in Guangdong).” *Xiju* 《戲劇》 2, no. 2 (October 1930): 52.
- . “Yige chenggong de haoxi *Guan Hanqing* 一個成功的好戲《關漢卿》 (A Successful Play, *Guan Hanqing*).” *Juben* 《劇本》 13 (1958): 25–27.
- Pang, Laikwan. *Building a New Cinema in China: the Chinese Left-wing Cinema Movement 1932-1937*. Lanham, MD: Rowman & Littlefield, 2002.
- . “Colour and Utopia: The Filmic Portrayal of Harvest in Late Cultural Revolution Narrative Films.” *Journal of Chinese Cinemas* 6, no. 3 (2012): 263–82.
- . *Creativity and Its Discontents: China’s Creative Industries and Intellectual Property Rights Offenses*. Durham, NC: Duke University Press, 2012.
- . *The Distorting Mirror: Visual Modernity in China*. Honolulu: University of Hawai’i Press, 2007. http://nrs.harvard.edu/urn-3:hul.ebookbatch.PMUSE_batch:muse9780824864675.
- “Peace Front: In Soviet Peace Committee.” *The Current Digest of the Russian Press* 10, no. 9 (April 17, 1957): 24–25.

Peng Xu. "Listening to Theater: The Arrival of the Gramophone and Soundscapes of Theater in China, 1890s-1920s." presented at the CHINOPERL Annual Conference, Seattle, March 31, 2016.

Performance program for *Guan Hanqing* 《關漢卿》, June 28, 1958. Shanghai Dramatic Arts Center Archive.

Performance program for *Guan Hanqing* 《關漢卿》, June 28, 1958. Beijing People's Art Theater Museum Archive.

Perry, Elizabeth. *Shanghai on Strike*. Stanford, CA: Stanford University Press, 1993.

Peters, Julie Stone. *Theatre of the Book 1480–1880*. Oxford University Press, 2003.
<http://www.oxfordscholarship.com/view/10.1093/acprof:oso/9780199262168.001.0001/acprof-9780199262168>.

Phelan, Peggy. *Unmarked: The Politics of Performance*. New York: Routledge, 1993.

"Premier Wen Says Science, Technology Key to China's Economic Development." *China View News*, December 27, 2009. http://news.xinhuanet.com/english/2009-12/27/content_12711291.htm.

Qinghua daxue jianzhu xi juyuan sheji zu 清華大學建築系劇院設計組. "Da juyuan sheji fang'an jieshao 大劇院設計方案介紹 (Introducing Design Plans for a Grand Theater)." *Jianzhu xuebao* 《建築學報》 4 (1960): 11–15.

Qinghua daxue tumu jianzhuxi juchang jianzhu shejizu shisheng 清華大學土木建築系劇場建築設計組師生, ed. *Zhongguo Huitang Juchang Jianzhu* 《中國會堂劇場建築》 (Chinese Auditorium and Theater Architecture). Beijing: Qinghua daxue tumu jianzhuxi, 1960.

Qiu, Jane. "China's Budget Backs Science." *Nature* 483, no. 7389 (March 13, 2012): 258–258. doi:10.1038/483258a.

Qiu Kunliang 邱坤良. *Renmin nandao meicuo ma? Nuhou Ba, Zhongguo! Teliejiyakefu yu Meiyehede* 《人民難道沒錯嗎? -- 〈怒吼吧, 中國!〉 特列季亞科夫與梅耶荷德》 (Can it be the People Were Not Wrong? *Roar, China!*, Tretiakov, and Meyerhold). Taipei: Taipei National University of the Arts and Ink Publishing, 2013.

Quah, Sy Ren. *Gao Xingjian and Transcultural Chinese Theater*. Honolulu: University of Hawai'i Press, 2004.

Quanguo wutai meishu zhanlanhui 全國舞台美術展覽會, ed. *Zhongguo wutai meishu* 《中國舞台美術》 (Stage Design of China). Beijing: Zhongguo xiju chubanshe, 1986.

Reinhardt, Max. “Laiyin hate yan zhong zhi juyuan 萊因哈特眼中之劇院 (The Theater in Max Reinhardt’s Eyes).” *Xiandai xiju* 《現代戲劇》 2, no. 2 (1929): 1–5.

Ren Yuren 任于人. “Ping Xi 評「戲」 (Reviewing Play).” *Xi* 《戲》 1, no. 2 (October 1933): 15.

Rhodes, Julian Baird Gewirtz. “The Vagina Monologues Comes to Beijing.” *The Huffington Post*, April 17, 2009. http://www.huffingtonpost.com/julian-baird-gewirtz/the-vagina-monologues-com_b_175031.html.

Roach, Joseph. *Cities of the Dead: Circum-Atlantic Performance*. New York: Columbia University Press, 1996.

“‘Roar, China!’ in Moscow,” *The Manchester Guardian*, December 14, 1926.

Robinson, Luke. “From ‘Public’ to ‘Private’: Chinese Documentary and the Logic of Xianchang.” In *The New Chinese Documentary Film Movement*, edited by Chris Berry, Lu Xinyu, and Lisa Rofel, 177–94. Hong Kong: Hong Kong University Press, 2010.

Rodekohl, Andy. “‘Human Wave Tactics’: Zhang Yimou, Cinematic Ritual, and the Problem of Crowds.” In *Red Legacies in China: Cultural Afterlives of the Communist Revolution*, edited by Jie Li and Enhua Zhang, 271–96. Cambridge, MA: Harvard University Press, 2016.

Rozmiarek, Joseph T. “A Melancholy Dane, Indeed.” *The Honolulu Advertiser*. March 22, 2006. <http://the.honoluluadvertiser.com/article/2006/Mar/22/en/FP603220307.html>.

Ruan Runxue 阮潤學. “Shanyu duoyanghua de shidai--ye tan dangdai xiju zhi mingyun 善於多樣化的時代——也談當代戲劇之命運 (An Era Adept at Diversification--Another Discussion on the Fate of Contemporary Theater).” *Zhongguo xiju* 《中國戲劇》 6 (2003): 13–14.

Rusanova, Olga. “Great Heritage: Chinese Classical Literature in Russian.” *Current Digest of the Post-Soviet Press*, Eastview Online database, 8, no. 23 (1956): 29–30.

Saich, Tony. *China’s Science Policy in the 80s*. Studies on East Asia (Atlantic Highlands, N.J.). Atlantic Highlands, NJ: Humanities Press International, 1989.

Salter, Chris. *Entangled: Technology and the Transformation of Performance*. Cambridge, Mass: MIT Press, 2010.

Salter, Denis, Mou Sen, and Wu Wenguang. “China’s Theatre of Dissent: A Conversation with Mou Sen and Wu Wenguang.” *Asian Theatre Journal* 13, no. 2 (1996): 218–28. doi:10.2307/1124526.

San tuan wutai zu 三團舞台組 (Troupe No. 3 Stage Division). “Guan Hanqing guanhou zuotanhui 《關漢卿》觀後座談會 (*Guan Hanqing* post-performance discussion). n.d. SDAC Archive.

San Wen 三文. “Nuhouba Zhongguo! 怒吼吧中國! .” *Shiri Tan* 《十日談》 5 (1933).

Sborgi-Lawson, Francesca R. “Music in Ritual and Ritual in Music: A Virtual Viewer’s Perceptions about Liminality, Functionality, and Mediatization in the Opening Ceremony of the 2008 Beijing Olympic Games.” *Asian Music* 42, no. 2 (2011): 3–18.
———. *The Narrative Arts of Tianjin: Between Music and Language*. Burlington, VT: Ashgate, 2011.

Schechner, Richard. *Environmental Theater*. New York: Applause, 1994.

Shanghai geming da pipan xizuo xiaozu 上海革命大批判寫作小組. “Ping Sitannisilafusiji tixi 評斯坦尼斯拉夫斯基‘體系’ (Evaluating the Stanislavski System).” *Renmin ribao* 《人民日報》, July 16, 1989.

Shanghai huaju zhi 《上海話劇志》 (Shanghai Spoken Drama Gazetteer), s.v. “Xiju xieshe 戲劇協社.” Shanghai: Baijia chubanshe, 2002.

“Shenme ye mei dianfu Feng Jiangzhou: wo dui Zhongguo yaogun mei zeren 什麼也沒顛覆丰江舟：我對中國搖滾沒責任 (Nothing Can Subvert Feng Jiangzhou: I’m Not Responsible for Chinese Rock and Roll).” *Dongfang zaobao* 《東方早報》, December 21, 2007. http://art.ce.cn/yymb/ylysj/200712/21/t20071221_13994439.shtml

Shen Yan 申燕. “‘Da yuejin’ yu shehui zhuyi wutuobang Xiju ‘大躍進’與社會主義烏托邦戲劇 (The Great Leap Forward and Socialist Utopian Drama).” *Wenyi yanjiu* 《文藝研究》 8 (2013): 95–102.

Shi Ming 石鳴. “Zhuli xiaojie: yinxiangpai de Sitelinbao 《朱麗小姐》：印象派的斯特林堡 (*Miss Julie: An Impressionist Strindberg*).” *Sanlian shenghuo zhoukan* 《三聯生活週刊》, May 29, 2014. <http://magazine.sina.com/gb/lifeweek/785/20140528/1638124458.html>.

Shi Yajuan 石雅娟, ed. *Dang women zaici xiangju: Zhongguo qingnian wengongtuan chufang 9 guo yinian ji* 《當我們再次相聚：中國青年文工團出訪9國一年記》 (When We Meet Again: Memories of the China Youth Arts Troupe Touring 9 Countries in One Year). Beijing: Wenhua yishu chubanshe, 2004.

“Shoudu juchang jiancheng 「首都劇場」建成 (The Construction of the Capital Theater).” *Xijubao* 《戲劇報》 11 (1955): 42–43.

“Shoudu longzhong jinian shijie wenhua mingren Guan Hanqing 首都隆重紀念世界文化名人關漢卿 (Grand Commemoration of the World Cultural Figure Guan Hanqing in the Capital).” *Xijubao* 《戲劇報》 11–12 (1958).

Shu Jun 樹軍. *Tiananmen guangchang lishi dang'an* 《天安門廣場歷史檔案》 (The Historical Archive of Tiananmen Square). Beijing: Zhonggong zhongyang dangxiao chubanshe, 1998.

Simon, Denis Fred, and Merle Goldman. *Science and Technology in Post-Mao China*. Cambridge, MA: Council on East Asian Studies, Harvard University, 1989.

Si Nairuo 斯乃若. “Guanyu xiju de biao'yan jishu 關於戲劇的表演技術 (Regarding Theater Performance Techniques).” *Zhandi* 《戰地》 2.8 (1939): 9–11.

Smith, Ken. “A Princess Comes Home.” *Opera* 63, no. 12 (2012): 1473–79.

Spence, Jonathan D. *The Search for Modern China*. 2nd ed. New York: W.W. Norton, 1999.

Stiegler, Bernard. *Technics and Time*. 3 vols. Stanford, CA: Stanford University Press, 1998.

“Sulian ge jieji hui jinian Guan Hanqing 蘇聯各階級會紀念關漢卿 (All classes in the Soviet Union Commemorate Guan Hanqing).” *Renmin ribao* 《人民日報》, June 22, 1958.

Su Min 蘇民 et al., ed. *Leiyu de wutai yishu* 《〈雷雨〉的舞台藝術》 (The Stage Art of Thunderstorm). Shanghai: Shanghai wenyi chubanshe, 1982.

Su Min, Zuo Lai et al. “A Chinese Director’s Theory of Performance: On Jiao Juyin’s System of Directing.” Translated by Shiao-ling Yu. *Asian Theatre Journal* 20, no. 1 (2003): 25–42.

Sun Haoran 孫浩然. “Guanju zatan 觀劇雜談 (Notes on Performances).” *Xijubao* 《戲劇報》 16 (1958): 31.

———. “Yingguo Huaju Yanchu de Guoqu Yu Xianzai 英國話劇演出的過去與現在 (The Past and Present of British Drama).” *Renmin xiju* 《人民戲劇》 8 (1980): 44–47.

Sun Kaidi 孫楷第. *Kuilei xi kaoyuan* 《傀儡戲攷原》 (Examining the Origins of Puppet Theater). Shanghai: Shang za chubanshe, 1952.

Sun, William Huizhu. “Mei Lanfang, Stanislavsky and Brecht on China’s Stage and Their Aesthetic Significance.” In *Drama in the People’s Republic of China*, edited by Constantine Tung and Colin Mackerras, 137–50. Albany: State University of New York Press, 1987.

Sun, William Huizhu, and Faye Chunfang Fei. “China Dream: A Theatrical Dialogue between East and West.” In *Intercultural Performance Reader*, edited by Patrice Pavis. New York: Routledge, 1996.

———. “The Old B Hanging on the Wall in the Changing Chinese Theatre.” *TDR: The Drama Review* 30 (1986): 84.

Sun Xinyu 孙昕昱. “Xiandai huaju yanchu zhong de shanbian--duomeiti yingxiang dui xiandai huaju de yingxiang chutan 現代話劇演出中的嬗變——多媒體影像對現代話劇的影響初探 (Transmutation in Modern Spoken Drama Performance--a Preliminary Discussion of the Influence of Multimedia Images on Modern Spoken Drama).” *Linqu jiaoxue* 《林區教學》 12 (2008): 111–12.

Tam, Kwok-kan. *Soul of Chaos: Critical Perspectives on Gao Xingjian*. Hong Kong: The Chinese University Press, 2001.

Tang, Xiaobing. “Echoes of Roar, China! On Vision and Voice in Modern Chinese Art.” *Positions: East Asia Cultures Critique* 14, no. 2 (Fall 2006): 467–94.

“Tansuo huaju yanchu de xin xingshi--Yuanzi yu aiqing zuotanhui xiao ji 探索話劇演出的新形式——《原子與愛情》座談會小記.” *Renmin xiju* 《人民戲劇》 5 (1980): 15–17.

Tao Jinsun 陶晶孫. “‘Roar Chinese’ (juqing lüeshu 劇情略述) (a description of the plot).” *Yuequn zhoukan* 《樂群月刊》 1, no. 4 (1929): 152–53.

Tatlow, Antony, Tak-Wai Wong, and Hong Kong International Brecht Seminar. *Brecht and East Asian Theatre: The Proceedings of a Conference on Brecht in East Asian Theatre*. Hong Kong: Hong Kong University Press, 1982. http://nrs.harvard.edu/urn-3:hul.ebookbatch.PMUSE_batch:muse9789882200449.

Thorpe, Ashley. *The Role of the Chou (“clown”) in Traditional Chinese Drama: Comedy, Criticism, and Cosmology on the Chinese Stage*. Lewiston: Edwin Mellen Press, 2007.

Tian Han. “Guan Hanqing.” In *The Columbia Anthology of Modern Chinese Drama*, edited by Xiaomei Chen, translated by Amy Dooling, 598–673. New York: Columbia University Press, 2010.

———. *Kuan Han-Ching, a Play*. Beijing: Foreign Languages Press, 1961.

“Tian Han nianbiao jianbian 田漢年表簡編 (A Brief Chronology of Tian Han).” In *Tian Han quanji* 《田漢全集》, Vol. 20. Shijiazhuang: Huashan wenyi chubanshe, 2000.

Tian Han 田漢. “Guan Hanqing 《關漢卿》.” *Juben* 《劇本》 5 (1958): 2–29.

———. *Guan Hanqing* 《關漢卿》. Beijing: Zhongguo xiju chubanshe, 1958.

———. *Guan Hanqing yanchu ben* 《關漢卿》演出本. Vol. 2, *Beijing renmin yishu juyuan yanchu juban xuan: 1952-2012* 《北京人民藝術劇院演出劇本選:1952-2012》, edited by Beijing renmin yishu juyuan 北京人民藝術劇院. (Beijing: Beijing chubanshe, 2012.

———. “Nuhouba, Zhongguo! (xu) 怒吼吧，中國！（續）(Roar, China! Preface).” *Nanguo zhoukan* 《南國周刊》 10 (1929): 491–504.

———. “Nuhouba, Zhongguo! 怒吼吧，中國！（Roar, China!）.” *Nanguo zhoukan* 《南國周刊》 9 (1929): 445–50.

———. Production script for *Guan Hanqing* 《關漢卿》, June 1958. Shanghai Dramatic Arts Center Archive.

———. “Shisanling shuiku changxiangqu 《十三陵水庫暢想曲》 (Fantasia of the Ming Tomb Reservoir).” In *Tian Han quanji* 《田漢全集》, 6:217–327. Shijiazhuang: Huashan wenyi chubanshe, 2000.

———. “Yi gaodu shehui zhuyi ganjin zhengqu xiju chuanguzhuo da fengshou 以高度社會主義幹勁爭取戲劇創作大豐 (Drive a Bumper Crop of Theatrical Creation by High Level Socialism).” *Juben* 《劇本》 4 (1958): 2–6.

Tian Han 田漢, and Wei Qixuan 韋啓玄. “Xiang Sulian xiju xuexi: Tian Han tongzhi tan quan Sulian juhuiyan guangan 向蘇聯戲劇學習: 田漢同志談全蘇聯劇會演觀感 (Learning from Soviet Drama: Comrade Tian Han on His Impressions of Soviet Performances).” *Juben* 《劇本》 2 (1958): 81–85.

Tretiakov, Sergei. *Roar, China!* Translated by F. Polianivska and Barbara Nixon. London: Martin Lawrence, 1931.

Tung, Constantine. “Introduction: Tradition and Experience of the Drama of the People’s Republic of China.” In *Drama in the People’s Republic of China*, edited by Colin Mackerras and Constantine Tung, 13–20. Albany: State University of New York Press, 1987.

Wagner, Rudolph. “The Chinese Writer in His Own Mirror: Writer, State, and Society – the Literary Evidence.” In *China’s Intellectuals and the State: In Search of a New Relationship*, edited by Merle Goldman, Timothy Cheek, and Carol Lee Hamrin, 183–232. Cambridge, MA: Council on East Asian Studies, Harvard University, 1987.

———. *The Contemporary Chinese Historical Drama: Four Studies*. Berkeley, CA: University of California Press, 1990.

Wang, Ban. *The Sublime Figure of History: Aesthetics and Politics in Twentieth-Century China*. Stanford, CA: Stanford University Press, 1997.

Wang Chaoge 王潮歌. “Guanyu women 關於我們 (About Us).” *Encore Mount Wutai*. Accessed April 14, 2016. <http://www.yjwts.com/index.php?m=content&c=index&a=lists&catid=26>.

Wang Chong 王翀. Beijing qingnian xijuji tebie jiemu 北京青年戲劇節特別節目. Interview by Yuan Teng 袁騰. China Radio International (Zhongguo guoji guangbo tai 中國國際廣播電視台), September 12, 2008. <http://hanenaka.wix.com/theatre-du-reve#!20080912/c1jjw>.

———. *Leiyu 2.0* 《雷雨 2.0》 (Thunderstorm 2.0). Performed by Théâtre du Rêve Expérimental at the Trojan Horse Theater, July 2012. Beijing, PRC. Video Recording.

———. *Qungui 2.0* 《群鬼 2.0》 (Ghosts 2.0). Performed by Théâtre du Rêve Expérimental, 2014. Video Recording.

———. *Yijing yisheng yibusheng* 《一鏡一生易卜生》 (Ibsen in One Take, 2012). Written by Oda Fiskum and performed by Théâtre du Rêve Expérimental at the Shanghai Dramatic Arts Center, November 2013. Shanghai, PRC. Video Recording.

- Wang, Jing. *High Culture Fever: Politics, Aesthetics, and Ideology in Deng's China*. Berkeley: University of California Press, 1996.
- Wang Jun 王軍. *Chengji* 《城記》 (City Record). Beijing: Shenghuo dushu xinzhì sanlián shūdiàn, 2003.
- Wang Ling 王鈴. "Wutai xiaoguo de zhifa 舞台效果的製法 (Methods of Making Stage Effects)." *Xiandai yanju* 《現代演劇》 1, no. 1 (1934): 31–32.
- Wang, Nan. "Philosophical Perspectives on Technology in Chinese Society." *Technology in Society* 35, no. 3 (August 2013): 165–71. doi:10.1016/j.techsoc.2013.05.001.
- Wang, Qi. "Performing Documentation: Wu Wenguang and the Performative Turn of New Chinese Documentary." In *A Companion to Chinese Cinema*, edited by Yingjin Zhang, 299–317. Malden, MA: Wiley-Blackwell, 2012.
- Wang Ren 王韜, and Huang Su 黃甦. "Wutai meishu: zai tansuo yu chuangzuo zhong qianjin 舞台美術：在探索與創造中前進 (Scenography: Moving Forward between Exploration and Creation)." *Renmin xiju* 《人民戲劇》 1 (1983): 5–6.
- Wang Ruilin 王瑞麟. "Daoyan jishu 導演技術 (Directing Technique)." *Xiju yu wenyi* 《戲劇與文藝》 1.7 (1929): 6-53
- Wang Tianxiang 王天翔. "Feng Jiangzhou: kuajie zhi jie you duoyuan 丰江舟：跨界之界有多遠 (Feng Jiangzhou: How Distant the Boundaries Crossed)." *Youpin* 《優品》, 2010.
- Wang Yongde 王泳德. "Zhubu di manzu laodong renmin dui wenhua shenghuo de yaoqiu, Beijing Tianqiao daxing juchang luocheng jijiang kaimu 逐步地滿足勞動人民對文化生活的要求,北京天橋大型劇場落成即將開幕 (Gradually Satisfying the Cultural Needs of the Working People, the Completion and Opening of Beijing Tianqiao Grand Theater)." *Guangming ribao* 《光明日報》, December 28, 1953.
- Wang Zheng 王正 et al., ed. *Fengxue ye guiren de wutai yishu* 《〈風雪夜歸人〉的舞台藝術》 (The Stage Art of Return on a Snowy Night). Beijing: Zhongguo xiju chubanshe, 1984.
- "Watery Grave Snug and Warm in 'Roar, China.'" *The New York Herald Tribune*, November 16, 1930.
- Weber, Samuel. *Theatricality as Medium*. New York: Fordham University Press, 2004.
- Wei Bingbing. "The Bifurcated Theater: Urban Space, Operatic Entertainment, and Cultural Politics in Shanghai, 1900s-1930s." Ph.D. Dissertation, National University of Singapore, 2013.

Wei Minglun 魏明倫. “Dangdai xiju zhi mingyun: zai Yuelu shuyuan yanjiang de yaodian 當代戲劇之命運：在岳麓書院演講的要點 (The Fate of Contemporary Theater: Main Points from a Lecture at Yuelu Academy.” *Zhongguo xiju* 《中國戲劇》 12 (2002): 4–6.

Wei Qixuan 韋啓玄. “Tian Han tongzhi chuanguo *Guan Hanqing* sanji 田漢同志創作‘關漢卿’散記 (Scatter Records of Comrade Tian Han Composing *Guan Hanqing*.” *Juben* 《劇本》 5 (May 1958): 34-37.

Wei Shuxian 魏淑嫻. “Yici changshi 一次嘗試 (A Trial).” *Xiju yishu* 《戲劇藝術》 4 (1981): 21–22.

“Wei yingjie Sulian liang da yishu tuanti lai woguo yanchu, Beijing liang zuo juchang de xiujian gongcheng zheng jiajin jinxing 為迎接蘇聯兩大藝術團體來我國演出，北京兩座劇場的修建工程正加緊進行...(Welcoming Two Great Arts Groups from the Soviet Union to Our Country, Quickening the Pace to Construct Two Theaters in Beijing).” *Renmin ribao* 《人民日報》，September 5, 1954.

Wenhua bu dangshi ziliao zhengji gongzuo weiyuanhui 文化部黨史資料征集工作委員會, ed. *Zhongguo zuoyi xiju jia lianmeng shiliao ji* 《中國左翼戲劇家聯盟史料集》 (Historical Materials from the League of Left-Wing Dramatists). Beijing: Zhongguo xiju chubanshe, 1991.

“Wenhua jie jinchen juxing jinian Guan Hanqing dahui: Guan Hanqing zuopin aizeng denming, zuguo gudian xiju de zhengui caifu 文化界今晨舉行紀念關漢卿大會：關漢卿作品愛憎分明，祖國古典戲劇的珍貴財富 (The Cultural World Meeting to Commemorate Guan Hanqing this Morning: What to Love and Hate in the Works of Guan Hanqing, the Riches of Our Country's Classical Drama).” *Xinmin xanbao* 《新民晚報》，June 28, 1958.

Wichmann, Elizabeth. *Listening to Theatre: The Aural Dimension of Beijing Opera*. Honolulu: University of Hawaii Press, 1991.

Wilcox, Emily. “Meaning in Movement: Adaptation and the Xiqu Body in Intercultural Chinese Theatre.” *TDR: The Drama Review* 58, no. 1 [T221] (2014): 42–63.
doi:10.1162/DRAM_a_00327.

———. “The Dialectics of Virtuosity: Dance in the People’s Republic of China, 1949–2009.” PhD Dissertation, University of California-Berkeley, 2011. <http://search.proquest.com/docview/896622153/>.

Williams, John A. “Lighting Spectacles in East and Southeast Asia.” *Asian Theatre Journal* 31, no. 2 (2014): 594–605.

Wu Chunhua 吳春花. “Lao Tianqiao juchang de na xie shi'er--fang Zhongyang xiju xueyuan Li Chang jiaoshou 老天橋劇場的那些事兒--訪中央戲劇學院李暢教授 (The Matter of the Old Tianqiao Theater--An Interview with Central Academy of Drama Professor Li Chang).” *Jianzhu xuebao* 《建築學報》 4 (2012).

Wu Hung. *Remaking Beijing: Tiananmen Square and the Creation of a Political Space*. Chicago: The University of Chicago Press, 2005.

———. “Tiananmen Square: A Political History of Monuments.” *Representations* 35 (1991): 84–117.

Wu Renzhi 吳仞之. “Wutai guang 舞台光 (Stage Lighting).” *Juchang yishu* 《劇場藝術》, no. 1,3,6 (1939 1938). 大成老舊刊全文數據庫.

Wu Wenguang 吳文光. *Xianchang (di Yi Juan)* 《現場 (第一卷)》. Tianjin: Tianjin shehui kexue yuan, 2000.

Wu Yingfu 吳英輔. “Taiwan shehui de zhongshengxiang--Hongbizi guanhou gan 台灣社會的眾生相——《紅鼻子》觀後感.” *Renmin ribao* 《人民日報》, March 19, 1982.

Xia Chun 夏淳. “Shenghuo wei wo shiyi--daoyan *Leiyu* shouji 生活為我釋疑——導演《雷雨》手記 (Life Dispels Doubt--Notes on Directing Thunderstorm).” In *Leiyu de wutai yishu* 《〈雷雨〉的舞台藝術》 (The Stage Art of Thunderstorm), edited by Su Min 蘇民 et al., 7–26. Shanghai: Shanghai wenyi chubanshe, 1982.

“Xiandai wutai gongju zhi yiban 現代舞台工具之一斑 (Tools of the Modern Stage).” *Juxue yuekan* 《劇學月刊》 2, no. 7–8 (August 1933).

Xiang, Hardy Yong, and Hui Zhang. “Development Report on the Performing Arts Industry (2011-2012).” In *China Cultural and Creative Industry Reports 2013*, edited by Hardy Yong Xiang and Patricia Ann Walker, 139–56. Heidelberg: Springer, 2014.

Xiang Peiliang 向培良. *Wutai secai xue* 《舞台色彩學》 (Color Studies for the Stage). Shanghai: Shangwu yinshua guan, 1935.

Xia Yan 夏衍. “Du Guan Hanqing zatan lishiju 讀關漢卿雜談歷史劇 (A Discussion of Various Topics on Historical Plays after Reading Guan Hanqing).” *Juben* 《劇本》 5 (1958): 4–6.

Xiju gongzuo yuejin jingyan xuanji 《戲劇工作越近經驗選輯》 (A Selection of Experiences from the Great Leap in Theater Work). Vol. 1. Shanghai: Shanghai wenyi chubanshe, 1958.

Xiju yishu yanjiu shi 戲劇藝術研究室, and Biaoyan xi biaoyan jiaoyan zu 表演系表演教研組. “Guanyu Sitannisilafusiji tixi de taolun 關於斯坦尼斯拉夫斯基體系的討論 (A Discussion of the Stanislavsky System).” *Xiju yishu* 《戲劇藝術》 1 (1978): 9–28.

Xingui 心規. “Tan zhaoming xuwan 談照明續完 (On Illumination, Continued).” *Kangdi xiju* 《抗敵戲劇》 2 no. 3-4 (1939).

Xinjun 欣君. “Xuxi *Chusheng de Taiyang* wutai meishu de tihui 學習《初升的太陽》舞台美術的體會 (Understanding Gained from Studying the Scenography of *The Rising Sun*).” *Renmin xiju* 《人民戲劇》 6 (1976): 20–21.

Xue Dianjie 薛殿傑. “Meiguo wutai meishu jianwen--fang Mei suibi erze 美國舞台美術見聞——訪美隨筆二則 (Sights and Sounds of American Scenography--Notes from a Trip to the US).” *Waiguo xiju* 《外國戲劇》 1 (1982): 123–29.

———. “Stage Design for Brecht’s *Life of Galileo*.” In *Brecht and East Asian Theatre: The Proceedings of a Conference on Brecht in East Asian Theatre*, edited by Antony Tatlow and Tak-Wai Wong, 72–87. Hong Kong: Hong Kong University Press, 1982.

Xu Lin. “Pushing the Boundaries.” *China Daily*, September 25, 2010. http://www.chinadaily.com.cn/life/2010-09/25/content_11343867.htm.

Xu Xiaozhong 徐曉鍾. “Ba ziji de xingshi fuyu ziji de guannian 把自己的形式賦予自己的觀念 (Endow One’s Own Form with One’s Own Concept).” In *Xu Xiaozhong daoyan yishu yanjiu* 《徐曉鍾導演藝術研究》, edited by Lin Yinyu 林蔭宇. Beijing: Zhongguo xiju chubanshe, 1991.

Xu Zhen 徐震. “Guanyu ‘xiju weiji’ de sikao 關於‘戲劇危機’的思考 (Reflections on the Theater Crisis).” *Xiju* 《戲劇》 2 (2014): 126–34.

Yang Jian 楊健. “Wenhua dageming zhong de hongweibing huaju 文化大革命中的紅衛兵話劇 (Red Guard Spoken Drama During the Cultural Revolution).” *Zhongguo qingnian yanjiu* 《中國青年研究》 1 (1995): 34–37.

———. “Wenhua dageming zhong de hongweibing huaju 文化大革命中的紅衛兵話劇 (Red Guard Spoken Drama During the Cultural Revolution).” *Zhongguo qingnian yanjiu* 《中國青年研究》 2 (1995): 25–28.

Yan, Haiping. “Theater and Society: An Introduction to Contemporary Chinese Drama.” In *Theater & Society: An Anthology of Contemporary Chinese Drama*, edited and translated by Haiping Yan, ix – xlvii. Armonk, NY: MESHARPE, 1998.

———. “Theatricality in Classical Chinese Drama.” In *Theatricality*, edited by Tracy C. Davis and Thomas Postlewait, 65–89. Cambridge, UK: Cambridge University Press, 2003.

Yao Yiwei 姚一葦. “Hong bizi 《紅鼻子》 (The Red Nose).” *Juben* 《劇本》 2 (1982): 46–82.

———. “Hong bizi 《紅鼻子》 (The Red Nose).” In *Yao Yiwei xiju liuzhong* 《姚一葦劇作六種》 (Six Plays by Yao Yiwei). Taipei: Shulin chuban youxian gongsi, 2000.

———. *Yao Yiwei xiju liuzhong* 《姚一葦劇作六種》. Taipei: Shulin chuban youxian gongsi, 2000.

Ye, Xiaoqing. *Ascendant Peace in the Four Seas: Drama and the Qing Imperial Court*. Hong Kong: Chinese University Press, 2012.

Yeh, Catherine Vance. "A Public Love Affair or a Nasty Game? The Chinese Tabloid Newspaper and the Rise of the Opera Singer as Star." *European Journal of Asian Studies* 2, no. 1 (2003): 13–51.

———. "Mei Lanfang's 'The Goddess Spreads Flowers' and the Inherent Ambiguity of Modernism." presented at the Association for Asian Studies Annual Conference, Seattle, WA, April 2, 2016.

———. "Recasting Peking Opera: Modern Dance, Invented Tradition and the Visual Turn." presented at the CHINOPERL Annual Conference, Seattle, WA, March 31, 2016.

"Censorship." *The Cambridge Guide to Theatre*. Cambridge, UK: Cambridge University Press, 1995.

Yeh, Ying-Chu. "A Translation of and Commentary on Red Nose (Hung Pi Tzu) - a Four-Act Play by Yao Yi-Wei (1922-)." Iowa State University, 1981.

Yifannuofu 伊凡諾夫. "Sulian renmin relie jinian Guan Hanqing 蘇聯人民熱烈紀念關漢卿 (The Soviet People Enthusiastically Commemorate Guan Hanqing)." *Xijubao* 《戲劇報》 12 (1958).

Yi Hongxia 易紅霞. "Duomeiti xiju: ke-mei shidai de xinxing xiju 多媒體戲劇：科媒時代的新型戲劇 (Multimedia Theater: New Forms of Theater in the Age of Science and Media)." *Nanguo Hongdou* 《南國紅豆》 S1 (2004): 48–51.

———. "Shuma shida de xiju, qi weiji, shengji yu duomeiti xingtai 數碼時代的戲劇，其危機，生機與多媒體形態 (The Theater of the Digital Age, its Crisis, Vitality, and Multimedia Form)." *Zhongguo xiju* 《中國戲劇》 8 (2004): 4–7.

Ying Ruocheng 英若城. "Xifang huaju biao'yan de xin faxian 西方話劇表演的新發現 (New Discoveries in Western Spoken Drama Performance)." *Renmin xiju* 《人民戲劇》 11 (1980): 45–48.

Ying Yunwei 應雲衛. "Nuhoubao Zhongguo shangyan jihua 怒吼吧中國上演計劃 (Production Design for *Roar, China*)." *Xi* 《戲》 1, no. 1 (1933): 58–59.

Yi Yun 逸雲. "Yanyuan de jishu 演員的技術 (Actors' Technique)." *Zhengzhi qianxian* 《政治前線》 2.12 (1941): 15-17.

Yuan Muzhi 袁牧之. "Liang ji kongshou juan - jidian shengming 兩記空手拳—幾點聲明 (Two Empty Fists-Several Points)." *Xi* 《戲》 1, no. 2 (October 1933): 21.

———. "Wei xiju yundong qiantu dasuan 為戲劇運動前途打算 (Plans for the Future of the Theater Movement)." *Xi* 《戲》 1, no. 1 (September 1933): 1.

Yue, Audrey. "New Media: Large Screens in China." In *The Oxford Handbook of Chinese Cinemas*, edited by Carlos Rojas and Eileen Cheng-yin Chow, 359–76. Oxford: Oxford University Press, 2013.

“Yueju yuan ganpai ‘Guan Hanqing’: xuduo zhuming yueju yanyuan jiang tongtai yanchu 越劇院趕排‘關漢卿’: 許多著名越劇演員將同台演出 (Yueju Theater Rushes to Rehearse Guan Hanqing: Many Renowned Yue Actors to Perform Together).” *Xinmin wanbao* 《新民晚報》, June 21, 1958.

Yu Shangyuan 余上沅. “Qinxian 《芹獻》 (My Humble Gift).” *Chenbao fukan* 《晨報》副刊, November 1923-May 1924.

———. *Xiju lunji* 《戲劇論集》 (Collected Essays on Drama). Shanghai: Beixinshuju, 1927.

———. *Xiju lunwen ji* 《戲劇論文集》 Wuhan: Changjiang wenyi chubanshe, 1986.

Zang Nuo 臧娜. “Liang zhong ‘xuni’ de jianxing jiedu yu shiyu jiaorong-- jiyu duomeiti jingju yinyue xiju de lilun sikao 兩種‘虛擬’的間性解讀與視域交融——基於多媒體京劇音樂戲劇的理論思考 (Discerning the Nature and Entanglement of Two Forms of 'Virtuality'--A Theoretical Discussion Based on Multimedia Beijing Opera and Musicals).” *Zhongguo xiqu xueyuan xuebao* 《中國戲曲學院學報》 35, no. 4 (November 2014): 108–10.

Zhang Fan 張帆. “Yiduan hualuo sheijia de wangshi--ji Shoudu juchang luocheng qianhou 一段花落誰家的往事——記首都劇場落成前後 (On Whose Home Did Blossoms Rain?--A Record of the Construction of the Capital Theater).” *Zongheng* 《縱橫》 4 (2007).

Zhang Geng 張庚. “Wei guanzhong de xiju jianghua: shiyi, wutai dengguang he xiaoguo 為觀眾的戲劇講話：十一 舞台燈光和效果 (Lectures on Theater for the Audience: (11) Stage Lighting and Effects).” *Shenghuo zhishi* 《生活知識》 1, no. 12 (1936): 606-608.

Zhang Hong. “Fragments of the Body in Chinese Contemporary Art.” In *The Body at Stake: Experiments in Chinese Contemporary Art and Theatre*, edited by Jörg Huber and Zhao Chuan. Bielefeld: Transcript, 2013.

Zhang Lian 張連, ed. *Zhongguo xiqu wutai meishu shilun* 《中國戲曲舞台美術史論》 (A History and Theory of Chinese Traditional Opera Stage Art). Beijing: Wenhua yishu chubanshe, 2000.

Zhang Ming'ai. “Zhang Yimou to Stop Filming, Direct Britain’s Turandot.” *China.org.cn*, April 1, 2012. http://www.china.org.cn/arts/2012-04/01/content_25043758.htm.

Zhang Xianheng 張先衡. “Yao zhuahao jibengong xunlian 要抓好基本功訓練 (We Must Fully Grasp Fundamental Training).” *Xiju yishu* 《戲劇藝術》 1 (1978): 159–61.

Zhang Xuejun 張學軍. “Shancun nü jiaoshi wutai xiaoguo bizhen, shanhong baofa shenlin qijing 《山村女教師》舞台效果逼真，山洪暴發身臨其境 (Lifelike Special Effects in *The Village Teacher*, Like a Sudden Torrent, Experience in Person).” *CCTV Entertainment*, December 18, 2009. <http://ent.cctv.com/20091218/102095.shtml>.

Zhang Yimou 張藝謀, Zhongyang dianshitai 中央電視台, Zhongguo guoji dianshi zonggongsi 中國國際電視總公司, and International Olympic Committee. *Beijing 2008 Aoyunhui kaimushi* 《北京 2008 奧運會開幕式》 (The opening ceremony of the Beijing 2008 Olympic Games). Beijing: Zhongguo guoji dianshi zonggongsi, 2008. DVD.

Zhang Yunqiao 張雲喬. “Ying Yunwei he huaju *Nuhouba, Zhongguo!* 應雲衛和話劇《怒吼吧，中國！》 (Ying Yunwei and the Spoken Drama *Roar, China!*).” *Shanghai tan* 《上海灘》 7 (1995): 38–39.

Zhang, Zhen. *An Amorous History of the Silver Screen: Shanghai Cinema, 1896-1937*. Cinema and Modernity. Chicago, Ill: University of Chicago Press, 2005.

———. “Building on the Ruins: The Exploration of New Urban Cinema of the 1990s.” In *Reinterpretation: A Decade of Experimental Chinese Art (1990-2000)*, edited by Wu Hung, Wang Huangsheng, and Feng Boyi, 112–20. Guangzhou: Guangzhou Museum of Fine Art, 2002.

———. “Introduction: Bearing Witness: Chinese Urban Cinema in the Era of Transformation (Zhuaxing).” In *The Urban Generation: Chinese Cinema and Society at the Turn of the Twenty-First Century*, edited by Zhang Zhen, 1–48. Durham, NC: Duke University Press, 2007.

———. “Teahouse, Shadowplay, Bricolage: Laborer’s Love and the Question of Early Chinese Cinema.” In *Cinema and Urban Culture in Shanghai, 1922-1943*, edited by Yingjin Zhang, 27–50. Stanford, Calif: Stanford University Press, 1999.

Zhang Zhongnian 張仲年, ed. *Zhongguo shiyan xiju* 《中國實驗戲劇》 (Experimental Drama of China). Shanghai: Shanghai renmin chubanshe, 2009.

Zhang Zunji 張傳吉. “Jieshao qingyi chuangzao de tu zhuntai 介紹青藝創造的土轉台 (An Introduction to the Homemade Revolving Stage made by the Youth Arts Troupe.” *Xijubao* 《戲劇報》 15 (1958): 35–36.

Zhao Mingyi 趙銘彝. “Guanyu zuoyi xijujia lianmeng 關於左翼戲劇家聯盟 (On the League of Left-Wing Dramatists).” *Zhongguo zuoyi xijujia lianmeng shiliaoji* 《中國左翼戲劇家聯盟史料集》, edited by the Wenhua bu dangshi ziliao zhengji gongzuo weiyuanhui 文化部黨史資料征集工作委員會. Beijing: Zhongguo xiju chubanshe, 1991.

Zhao Xun 趙尋. “Xu 序 (Preface).” In *Leiyu de wutai yishu* 《〈雷雨〉的舞台藝術》 (The Stage Art of Thunderstorm), edited by Su Min 蘇民 et al., 5–6. Shanghai: Shanghai wenyi chubanshe, 1982.

Zhao, Yiheng. *Towards a Modern Zen Theatre: Gao Xingjian and Chinese Theatre Experimentalism*. London: School of Oriental and African Studies, University of London, 2000.

Zheng Yan 鄭焱, Liu Xiaotong 劉小同, and Xu Chunxiao 許春曉. “Shijing yanchu youke ganzhi, qinggan, manyi de guanxi tanjiu 实景演出游客感知、情感、满意的关系探究 (An Exploration of the Relationship among Real-Scenery Performance Tourists’ Perception, Feeling, and Satisfaction).” *Luyou yanjiu* 《旅遊研究》 5, no. 2 (2013): 42–49.

Zhi Bin 志彬. “Guan Hanqing xiqu ji shiyi yue chuban 關漢卿戲曲集十一月出版 (Collected Xiqu works of Guan Hanqing to be Published in November.” *Renmin ribao* 《人民日報》, October 26, 1957.

Zhongguo jingju tuan 中國京劇團. *Geming xiandai jingju Hongdengji* 《革命現代京劇紅燈記》 (Modern Revolutionary Jingju The Red Lantern). Beijing: Renmin chubanshe, 1970.

Zhongguo wuju tuan 中國舞劇團. *Geming xiandai wuju Hongse niangzi jun* 《革命現代舞劇紅色娘子軍》 (Modern Revolutionary Dance-drama The Red Deachment of Women). Beijing: Renmin chubanshe, 1970.

Zhongguo xijujia xiehui yishu weiyuanhui wutai meishu zu 中國戲劇家協會藝術委員會舞台美術組, ed. *Wutai meishu gongzuo jingyan jianjie* 《舞台美術工作經驗簡介》 (A Brief Introduction of Experience Working in Scenography). Beijing: Zhongguo xijujia xiehui yishu weiyuanhui, 1957.

Zhongguo xiquzhi bianji weiyuanhui 中國戲曲志編輯委員會. *Zhongguo xiqu zhi* 《中國戲曲志》 Shanghai juan 上海卷 (Chinese Xiqu Gazetteer, Shanghai volume). Beijing: Zhongguo ISBN zhongxin, 1996.

———. *Zhongguo xiqu zhi* 《中國戲曲志》. Beijing juan, shang 北京卷上 (Chinese Xiqu Gazetteer, Beijing volume 1). Beijing: Zhongguo ISBN zhongxin, 1999.

Zhongguo yishu yanjiuyuan xiqu yanjiusuo 中國藝術研究院戲曲研究所, ed. *Wutai meishu wenji* 《舞台美術文集》 (Collected Essays on Scenography). Beijing: Zhongguo xiju chubanshe, 1982.

“Zhongguo zuoyi zijujia lianmeng zuijin xingdong gangling 中國左翼戲劇家聯盟最近行動綱領 (Guiding Principles for the Recent Activities of the Chinese League of Left-Wing Dramatists).” *Wenxue daobao* 《文學導報》 no. 6-7 (October 23, 1931).

Zhonghua renmin gongheguo wenhuabu, ed. *Zhongguo wenhua nianjian* 《中國文化年鑑 2012》 (Almanac of Chinese Culture 2012). Beijing: Xinhua chubanshe, 2013.

Zhou Chunyu 周春雨. “Ganshou duomeiti xiju de zhenhan 感受多媒體戲劇的震撼 (Experiencing the Thrill of Multimedia Theater).” *Shanghai xiju* 《上海戲劇》 10 (2003): 13–14.

Zhou Enlai 周恩來. “Zai Zhonghua quanguo wenxue yishu gongzuozhe daibiao dahui shang de zhengzhi baogao 在中華全國文學藝術工作者代表大會上的政治報告 (Political Report at the All-China Congress of Representatives from Art and Culture Workers).” In *Zhou Enlai lunwen ji* 《周恩來論文集》, 24–25. Beijing: Renmin wenxue chubanshe, 1979.

Zhou Yibai 周貽白. *Zhongguo ju chang shi* 《中國劇場史》 (A History of Chinese Theaters). 2nd Edition. Changsha: Shangwu yinshua guan, 1940.

Zhu, Jianfei. *Architecture of Modern China: A Historical Critique*. New York: Routledge, 2009.

Zung, Cecilia S. L. *Secrets of the Chinese Drama; a Complete Explanatory Guide to Actions and Symbols as Seen in the Performance of Chinese Dramas*. Shanghai, Kelly and Walsh, 1937.

Zuolin, Huang. "Fusing of Revolutionary Realism with Revolutionary Romanticism. (Shanghai People's Art Theatre) (Chinese and Overseas Chinese Theatre)." *TDR: The Drama Review* 38, no. 2 (1994): 18–28.

"Zuotan Tian Han xinzuo *Guan Hanqing* 座談田漢新作《關漢卿》 (Conference on Tian Han's New Work *Guan Hanqing*)." *Xijubao* 《戲劇報》 9 (1958): 14-18.

Zuni Icosahedron. Accessed September 13, 2015. <http://www.zuni.org.hk/new/zuni/web/default.php?cmd=performance>.