

SHEFFIELD HALLAM UNIVERSITY
LEARNING CENTRE
COLLEGIATE CRESCENT
SHEFFIELD S10 2BP

Handwritten mark

101 963 666 1



T

REFERENCE

ProQuest Number: 10702937

All rights reserved

INFORMATION TO ALL USERS

The quality of this reproduction is dependent upon the quality of the copy submitted.

In the unlikely event that the author did not send a complete manuscript and there are missing pages, these will be noted. Also, if material had to be removed, a note will indicate the deletion.



ProQuest 10702937

Published by ProQuest LLC (2017). Copyright of the Dissertation is held by the Author.

All rights reserved.

This work is protected against unauthorized copying under Title 17, United States Code
Microform Edition © ProQuest LLC.

ProQuest LLC.
789 East Eisenhower Parkway
P.O. Box 1346
Ann Arbor, MI 48106 – 1346

**MODELLING BASED FRAMEWORK FOR THE
MANAGEMENT OF EMERGENCY
DEPARTMENTS**

Uthumange Anura Kumara

**A thesis submitted in partial fulfilment of the requirements of
Sheffield Hallam University
for the degree of Doctor of Philosophy**

November 2009

DECLARATION

This thesis is submitted in partial fulfilment of the requirements of Sheffield Hallam University for the degree of Doctor of Philosophy. Except where acknowledgment and reference is appropriately made, this work is, to the best of my knowledge, original and has been carried out independently. No part of this thesis has been, or is currently being submitted for any degree or diploma at this or any other University.

UTHUMANGE ANURA KUMARA

October 2009

ACKNOWLEDGEMENT

I would like to express my deepest gratitude and appreciation to my supervisor Professor Terrence Perera for his guidance, constructive criticism and encouragement during the course of this study. I would also like to thank Dr David Clegg as the second supervisor of this research.

My appreciation and thanks also extends to Dr Derek Burke, Medical Director, Sheffield Children's Hospital and all the managers, consultants and officers in hospitals who participated in the data-collection process of this research.

I also wish to thank my colleagues, Osama, Mohamed, Julian, Sulaman, Rubi, Jane, Sivaprakash and the administrative staff of the Materials and Engineering Research Institute for their help and support.

Finally, I would like to express heartfelt thanks to my loving wife Rupa Kalansuriya and two lovely daughters Dinithi and Sahani for their invaluable support and patience during the completion of this research.

ABSTRACT

In the twenty-first century, the healthcare industry faces ever-changing economic, social, political and technology challenges. Costs are rising, funding is diminishing, human and fiscal resources are becoming scarcer, customer-expectations are rising, the complexity of disease is increasing and technology is becoming more complex. These trends have a massive impact on every aspect of hospital operations and the Emergency Department is no exception. Overcrowding in the Emergency Department (ED) in hospitals has become a growing problem in many developed countries around the world. ED overcrowding has a direct effect on patient-care, including compromised patient-safety, increased length-of-stay, increased mortality and morbidity-rates and increased costs. Healthcare policy-makers and hospital and ED administrators are being forced to search for ways to improve the capacity of EDs by better utilisation of existing resources and creating more efficient systems to overcome this problem.

Throughout the past few decades, there has been an increasing trend of using numerous systems-analysis tools and techniques which have come from manufacturing and other service industries to address the various issues in healthcare and EDs. Among those tools Discrete-Event Simulation (DES) is a powerful tool to improve the efficiency and capacity in dynamic and complex systems. Use of these tools to address the overcrowding problem in EDs has been patchy; specific aspects of issues have been studied but no attempt has been made to deploy DES or any other systems-analysis tool in a strategic and holistic manner.

The aim of this research is to develop a modelling-based framework to manage the overcrowding problem in EDs. The research identified the causes of overcrowding in EDs and developed a decisions-framework with the long-term, medium-term and short-term decisions in EDs that related to the overcrowding problem. Finally, it identified the best possible systems-analysis tools to support those decisions to overcome the overcrowding problem in EDs. This research could help the healthcare policy-makers, managers, systems-engineers as well as the researchers and consultants who are interesting in the Emergency Department operational management.

ABBREVIATIONS

A&E: Accident & Emergency

AAP: American Academy of Pediatrics

ACEP: American College of Emergency Physicians

AHWAC: Australia Health Workforce Advisory Committee

BAEM: British Association for Emergency Medicine

BMA: British Medical Association

BSC: Balanced Score Cards

CAEP: Canadian Association of Emergency Physicians

CDC: Centers for Disease Control

DES: Discrete-Event Simulation

DSS: Decision Support System

ED: Emergency Department

EDC: Emergency Department Crowding

EDs: Emergency Departments

ER: Emergency Room

EW: Emergency Ward

GAO: Government Accountability Office

GP: General Practitioner

JCAHO: Joint Commission on Accreditation of Healthcare Organizations

LOS: Length of Stay

NHS: National Health Service

SD: System Dynamics

TABLE OF CONTENTS

CHAPTER ONE

1. Introduction	1
1.1 Background to the Research.....	1
1.2 Justification for the Research.....	2
1.3 Aim and Objectives.....	5
1.4 Outline of the Thesis.....	6
1.5 Summary.....	8

CHAPTER TWO

2. Literature Review	9
2.1 System-modelling.....	9
2.1.1 System.....	9
2.1.2 Modelling.....	10
2.1.3 Types of Model.....	11
2.2 Simulation-modelling.....	14
2.2.1 Types of Simulation-model.....	16
2.3 The Role of Simulation.....	19
2.3.1 The Advantages of Simulation.....	22
2.3.2 The Disadvantages of Simulation.....	23
2.4 Steps in a Simulation Study.....	23
2.5 Simulation Software.....	27
2.6 Simulation Applications.....	28
2.7 Simulation in Healthcare.....	30
2.8 The Importance of Simulation in Emergency Departments.....	35
2.9 Other Tools and Techniques.....	39
2.9.1 Queuing Theory.....	39
2.9.2 System Dynamics.....	40
2.9.3 Balanced Scorecards.....	41
2.9.4 The Lean and Six Sigma.....	43
2.10 Modelling-based Frameworks in Healthcare.....	45
2.11 Summary.....	46

CHAPTER THREE

3. Research Methodology	47
--------------------------------------	-----------

3.1 Research Approach	47
3.2 Research Strategy.....	50
3.2.1 Grounded Theory	53
3.2.2 Case-study Analysis.....	54
3.2.3 Stakeholder Interviews.....	55
3.3 The Development of the Framework	57
3.4 Summary	57
CHAPTER FOUR	
4. An Overview of the Emergency Department in Hospitals	59
4.1 Emergency Department of Hospitals	59
4.1.1 Areas and functions of ED	61
4.1.2 Resources in EDs	63
4.1.3 ED Processes.....	65
4.2 Emergency Departments in the UK	68
4.3 The ED in Sheffield Children’s Hospital.....	71
4.4 Summary	76
CHAPTER FIVE	
5. The Overcrowding Problem in Emergency Departments.....	77
5.1 Definitions of Overcrowding	77
5.2 The Consequences of Overcrowding	79
5.3 The Causes of Crowding.....	85
5.3.1 Demand for ED Care.....	88
5.3.2 Inefficient ED Process and Policies	89
5.3.3 Shortage of Staff	90
5.3.4 Insufficient Facilities, Resources and Technology	92
5.3.5 Factors beyond the ED and Hospital.....	94
5.4 Solutions for ED Overcrowding.....	99
5.5 Summary	101
CHAPTER SIX	
6. The Development of a Decisions-framework for Emergency Departments	102
6.1 The Classification of Decisions in ED.....	102
6.1.1 The Level of the Decisions	102
6.1.2 The Category of Decisions.....	103
6.2 The Decisions-framework for the ED	104

6.3 Strategic-level (Long-term) Decisions.....	110
6.3.1 Introducing New Policies or Changes.....	110
6.3.2 Planning and Recruiting the Workforce.....	112
6.3.3 Planning Facilities and Technology.....	114
6.4 Tactical Level (Medium-Term) Decisions.....	115
6.4.1 Improving the ED Process	115
6.4.2 Scheduling Staff.....	116
6.4.3 Allocating Resources and Equipments.....	117
6.5 Operational Level (Short-Term) Decisions.....	117
6.5.1 Managing Patient-flows	117
6.5.2 Scheduling Patients for Doctors.....	119
6.5.3 Scheduling Patients for Shared Resources.....	120
6.6 Validation of the Decisions-framework	120
6.7 Summary	121

CHAPTER SEVEN

7. The Identification of Possible Tools for the Strategic Level Decisions in ED ...	122
7.1 Introducing New Policy or Changes	122
7.1.1 Discrete-event Simulation.....	122
7.1.2 System Dynamics.....	126
7.1.3 Balanced Scorecards	129
7.2 Planning and Recruiting the Workforce.....	131
7.2.1 Discrete-event Simulation.....	131
7.2.2 Queuing Theory	133
7.3 Planning Facilities and Technology.....	133
7.3.1 Discrete-event Simulation.....	134
7.3.2 Queuing Theory	138
7.4 Summary	139

CHAPTER EIGHT

8. The Identification of Possible Tools for the Tactical Level Decisions in ED.....	141
8.1 Improving the ED Process	141
8.1.1 Discrete-event Simulation.....	141
8.1.2 System Dynamics.....	145
8.1.3 Lean and Six Sigma	147
8.2 Scheduling Staff.....	149

8.2.1 Discrete-event Simulation.....	150
8.2.2 Queuing Theory	152
8.3 Allocating Resources and Equipment	153
8.3.1 Discrete-event Simulation.....	153
8.3.2 Queuing Theory	155
8.4 Summary	156
CHAPTER NINE	
9. The Identification of Possible Tools for the Operational Level Decisions in ED	158
9.1 Managing Patient-flows	158
9.1.1 Discrete-event Simulation.....	159
9.1.2 Queuing Theory	160
9.2 Scheduling Patients for Doctors.....	161
9.2.1 Discrete-event Simulation.....	161
9.2.2 Queuing Theory	163
9.3 Scheduling Patients for Shared Resources.....	164
9.3.1 Discrete-event Simulation.....	164
9.3.2 Queuing Theory	165
9.4 Summary	166
CHAPTER TEN	
10. Conclusion.....	168
10.1 Conclusions.....	168
10.2 Contribution to Knowledge.....	173
10.3 Future Work	175
REFERENCES.....	176
APPENDIX 1 Required Resources for EDs	1- 6
APPENDIX 2 Paired T-test to compare the hourly patient-arrivals between the days of the week.....	1- 2
APPENDIX 3 Paired T-test to compare the daily patient-arrivals between the months of the year	1- 3
APPENDIX 4 Introduction to IDEF0.....	1- 3
APPENDIX 5 The schedule for the validation of the decisions-framework	1- 2

LIST OF TABLES

Table 2.1	Use of Simulation in Healthcare in 1999-2004.....	33
Table 3.1	Induction Approach versus Deduction Approach.....	49
Table 4.1	Staff in a typical Emergency Department.....	64
Table 4.2	Patient-attendance and waiting more than four hours in England....	70
Table 4.3	Patient-arrivals by Triage-category (2005).....	74
Table 5.1	The consequences of crowding in ED and references.....	84
Table 5.2	Reasons for not reaching the four hour waiting target in the UK...	87
Table 5.3	Summary of the Causes of ED Overcrowding and References.....	96
Table 7.1	Matrix of the Strategic Level Decisions in ED and Possible Tools...	139
Table 8.1	Matrix of the Tactical Level Decisions in ED and Possible Tools.....	156
Table 9.1	Matrix of the Operational Level Decisions in ED and Possible Tools.....	166
Table 10.1	Matrix of Emergency Department Decisions and Possible Tools.....	171

LIST OF FIGURES

Figure 2.1	Types of System Model.....	13
Figure 2.2	Schematic of a Simulation Stud.....	16
Figure 2.3	Simulation Taxonomy.....	18
Figure 2.4	Steps in Simulation Projects.....	25
Figure 3.1	Deduction Approach.....	48
Figure 3.2	Induction Approach.....	48
Figure 3.3	The Research Methodology and Process.....	58
Figure 4.1	Patient-flows Through a Typical Emergency Department.....	69
Figure 4.2	Annual Attendance at Sheffield Children’s Hospital (2000-2005).....	72
Figure 4.3	Hourly Patient-arrivals on the Days of the Week in 2005.....	73
Figure 4.4	Patients Process Flow in the Emergency Department.....	75
Figure 5.1	Trends in EDs in the United States, 1994–2004.....	89
Figure 5.2	Causes of ED Overcrowding.....	98
Figure 6.1	Decision-Levels in the Emergency Department.....	105
Figure 6.2	Policy and Process Decisions in the Emergency Department.....	106
Figure 6.3	Personnel Decisions in the Emergency Department.....	107
Figure 6.4	Facility, Resources & Technology Decisions in the ED.....	108
Figure 6.5	Decisions-framework for Emergency Department.....	110

CHAPTER ONE

1. Introduction

1.1 Background to the Research

Emergency Departments (EDs) in hospitals assess and treat people with serious injuries and those in need of emergency treatment. Acute illnesses and traumatic injuries happen at any time. Therefore, EDs are usually open 24 hours a day, 365 days of the year. Often an ED is the only source of emergency medical care. Unfortunately, overcrowding and increasing delays in many emergency departments has been recognised as a growing problem around the world (Kollek and Walker, 2002; Graff, 1999; Schafermeyer and Brent 2003; McManus, 2001; Derlet et al., 2001; McCaig and Burt, 2004; Cowan and Trzeciak, 2005). This problem has been recognized since the early 1990s (Andrulis et al., 1991).

Over the last two decades, hospitals have been struggling to manage this overcrowding problem with scarce resources and an increase in patient-demand. According to the Lewin Group (2002), 62% of all hospital EDs and more than 90% of large hospitals EDs in the United States are operating "at" or "over" capacity. A 2001 survey of ED medical directors in the state of Washington also revealed that 100% of large hospitals and 91% of small hospitals were reporting overcrowding problems (ACEP, 2002). This problem is not limited to the United States, and overcrowding and long delays in EDs have been cited as acute and growing in other countries as well (Fatovich, 2002). Bradley (2005) also shows that overcrowding and long stays have been reported in the United States, United Kingdom, Australia, Canada, and Spain, demonstrating that this problem is not unique to the US healthcare system. The UK Audit Commission (2001) has highlighted the fact that accident and emergency waiting-times to see a doctor and

to be admitted to hospital have increased steadily since 1996. EDs in many developed countries face similar difficulties in terms of long waiting-times, staff-resourcing problems, and capacity limitations (Brailsford et al., 2003).

The potential dangers of ED overcrowding have recently garnered national attention in the United States. ED overcrowding threatens patient safety and public health in the US and numerous stories cited in the lay-press have reported an unsafe environment in EDs because of overcrowding (Trzeciak and Rivers, 2003). ED overcrowding has a direct effect on patient-care, including compromised patient safety, increased costs, increased length of stay, and increased mortality and morbidity-rates. The overcrowding represents a challenge for hospital employees and clients, often leading to frustration and dissatisfaction as well.

As a result of these problems, hospital administrators and other healthcare policy-makers are being forced to search for ways to improve the capacity of EDs by better utilisation of existing resources and creating more efficient systems. The crisis-level overcrowding problem has led to increased interest in analytical methods that allow ED activity to be studied at a system level (Connelly and Bair 2004). Unlike most other industries, hospital administrators cannot directly control demand. Their ability to manage their facilities depends on their effectiveness in utilizing scarce resources. Therefore, this crisis in EDs has compelled researchers and healthcare professionals to examine new ways to improve efficiency and reduce the overcrowding problem.

1.2 Justification for the Research

Over the past few decades, numerous systems-analysis tools and techniques from manufacturing and service industries have been approached to healthcare. These methods include Queuing Theory, Discrete-event Simulation, System Dynamics, Lean

Thinking, Six Sigma, Theory of Constraints, Supply-chain Management and Balanced Scorecards. Among them Discrete-Event Simulation (DES) is a powerful and successful tool used in many products and service industries (Law and Kelton ,1991).

Most systems-analysis tools are generally used to analyze existing systems for improvement. Mathematical analyses of system-operations include Queuing Theory, which could be used, for example, to understand the flow of patients through a system, the average time patients spend in the system or bottlenecks in the system. When complex changes and multiple implementations are made, the results are often impossible to predict accurately using most systems-analysis tools and conventional tools such as spreadsheets and flowcharts. This makes consensus on ideas for improvements difficult to attain. Simulations can be used as tools that enable EDs to conduct accurate and objective predictive analyses of the effects of process-improvements, facilities-changes, and new designs prior to implementation.

Discrete-event Simulation is an operational research technique that allows the end-user to assess the efficiency of existing delivery-systems, to ask 'what if?' questions, and to design new systems. DES can also be used to forecast the impact of changes in flows, to examine resource-needs or to investigate the complex relationships among the different model-variables (Jun 1999). DES helps to predict the outcome of decisions, to visualize, analyse, and optimize before committing capital and resources (Pollak et al., 2004). Simulation is more effective than analytical solutions for complex models, where the state of the system changes over time (Law and Kelton, 1991). Emergency Departments are considered one of the most complex systems to analyze. Rakich et al., (1991) state that simulation can assist hospital management to develop and enhance their decision-making skills when evaluating different operational alternatives in order to improve existing EDs or assist in designing and planning new EDs.

Throughout the nearly three decades, there is an increasing trend of using computer-simulation to address the various problems in healthcare and Emergency Departments including the long-waiting-time problem. In recent years, the application of Discrete-event Simulation in healthcare has become increasingly wide-spread covering almost all areas such as Emergency Departments, operating-theatres, clinics, outpatient and inpatient wards, ancillaries, and pharmacies. (Jun, 1999; Fone et al., 2003). But the application of simulation-modelling in the healthcare sector is not wide-spread when compared to other sectors such as the military, manufacturing and logistics sectors, despite the fact that simulation has been successfully used in these other sectors for some three decades (Baldwin et al., 2004). Efforts to develop computer-simulation of ED operations have been advancing since the late 1980s when Saunders et al. (1989) simulated a generalized ED. Since that time DES models have been used to study a wide range of factors such as the effect of changes in staffing-levels, the consequences of ED closures, and variables influencing patient-throughput (Lloyd and Aaron, 2004). Several studies have attempted to analysis the patient-flows to reduce the waiting-time and throughput-time at various stages in the Emergency Departments (Garcia et al., 1995; Mahapatra et al., 2003; McGuire1994; Samaha, Armel, and Starks, 2003). In addition, Emergency Department staff-scheduling also has been addressed (Centeno et al., 2003). Most simulation studies in Emergency Departments and healthcare are aimed to address specific problems in particular healthcare facilities. The commonalities in these studies are their objectives of improving performance such as reducing waiting-times or using resources more efficiently. Because they are specific, these studies guide a modeller as to how a specific problem can be solved (Günel and Pidd, 2007).

Even though overcrowding in EDs has been a serious problem for nearly two decades, no holistic-level attempt has been made to address this overcrowding problem using

simulation or other modelling tools. Use of simulation tools to address the issues in EDs has been patchy; specific aspects of issues have been studied using simulation but no attempt has been made to deploy simulation in a strategic manner. To make simulation a mainstream management-support-tool within Emergency Departments and to make a real impact, a more strategic and systematic approach is required to deploy and use simulation technologies. Therefore, it is important to identify the possibility of successfully using simulation and other alternative tools to address the overcrowding problem and develop a modelling-based decision-support infrastructure for the Emergency Department.

1.3 Aim and Objectives

Aim

The aim of this research is to develop a modelling-based framework to manage the overcrowding problem in Emergency Departments in hospitals.

To achieve this aim, the following objectives are set in this research.

Objectives

1. To investigate the current practices and applications of simulation in the healthcare and emergency-care.
2. To study the Emergency Department system and its operations.
3. To investigate the Emergency Department overcrowding problem and identify the causes of overcrowding.
4. To develop a holistic-level ED decisions framework that can be used to address the overcrowding problem in Emergency Departments.
5. To identify the possibility of using Discrete-event Simulation and other alternative tools in ED decision-making to overcome the overcrowding problem.

1.4 Outline of the Thesis

This thesis consists ten chapters. Each chapter starts with an introduction which briefly explains the contents of the chapter, and ends with a summary drawing conclusions from the chapter. The contents of each chapter are outlined as follows.

Chapter 1: Introduction

This chapter gives an overview of the research and explains the background, the justification for the research problem, and the aims and objectives of the research as well as outlining the contents of the thesis.

Chapter 2: Literature Review

This presents the concept of modelling and simulation in the context of the present research. It also discusses the current simulation practices and applications in healthcare and emergency-care, and the importance of simulation in the emergency department. Finally it gives a brief introduction about the other alternative tools and techniques that could be used in ED decision-making.

Chapter 3: Research Methodology

This chapter describes the research methodology adopted in this research. It justifies the research approaches, research strategies as well as the research type and methods used to achieve the multiple objectives of this research.

Chapter 4: An Overview of the Emergency Department in Hospitals

Chapter Four attempts to give an overview picture of the Emergency Department system and its operations. First it gives a general introduction about emergency-care and Emergency Departments including the ED function, resources and processes. Then it attempts to explore Emergency Departments in England.

Chapter 5: The Overcrowding Problem in Emergency Departments

This chapter discusses the overcrowding problem within the context of this research, based on the literature and the findings of the interviews with ED managers in England. It includes definitions of overcrowding, and its consequences and causes as well as the remedies which have been taken to overcome it. Finally, it presents the causes of overcrowding in a Fish-bone Diagram.

Chapter 6: The Development of a Decisions-framework for Emergency Departments

This chapter develops a decisions-frame which can be used to address the overcrowding problem in Emergency Departments. This ED decisions-frame includes nine decisions covering long-term, medium-term and short-term decisions in ED. All these decisions are selected based on the causes of overcrowding found in Chapter 5. It also discusses each of the decisions in detail, including the outcomes of the decisions.

Chapter 7: The Identification of Possible Tools for the Strategic Level Decisions in ED

This chapter analyses the possibility of using Discrete-event Simulation and other alternative tools and techniques in the long-term decisions in the framework explained in Chapter 6. The analysis and discussion is conducted under three strategic-level decision-headings: Introducing New Policy or Changes; Planning and Recruiting Workforce; and Planning Facilities and Technology.

Chapter 8: The Identification of Possible Tools for the Tactical Level Decisions in ED

This chapter analyses the possibility of using Discrete-event Simulation and other alternative tools and techniques in the medium-term decisions in the framework

described in Chapter 6. The analysis and discussion is conducted under three tactical-level decision-headings: Improving the ED Process, Scheduling Staff, and Allocating of Resources and Equipment.

Chapter 9: The Identification of Possible Tools for the Operational Level Decisions in ED

This chapter analyses the possibility of using Discrete-event Simulation and other alternative tools and techniques in the short-term decisions using the framework described in Chapter 6. The analysis and discussion is conducted under three operational-level decision-headings: Managing Patient-flows; Scheduling Patients for Doctors; and Scheduling Patients for Shared Resources.

Chapter 10: Conclusion

This is the last chapter in this thesis. This chapter presents the conclusions of the research, contribution to knowledge and the future work which is necessary.

1.5 Summary

This chapter presented the introduction to the research. It included the background of the research, and the justification for the research as well as its aims and objectives. It also included an outline of the thesis. A comprehensive survey of the literature on relevant concepts is presented in the following chapter of the research.

CHAPTER TWO

2. Literature Review

This chapter mainly presents the concept of modelling and simulation in the context of the present research. It also discusses the current simulation practices and application in healthcare and emergency departments and the importance of simulation in the emergency departments. Finally, it gives a brief description about the non-simulation tools and techniques that can be used in ED decision-making other than the simulation and their applications in healthcare.

2.1 System-modelling

The term system-modelling includes two important commonly-used concepts: system and modelling. It is imperative to clarify such concepts before attempting to focus on their relevance to this research. Hence, this section introduces these two concepts and provides generic classification of the various types of system-models..

2.1.1 System

The word system is commonly used in its broad meaning in a variety of engineering and non-engineering fields. In simple words, a system is often referred to as a set of elements or operations that are organized and logically related toward the attainment of a certain goal or objective. A system is defined to be a collection of entities, e.g., people or machines that act and interact together toward the accomplishment of some logical end (Schmidt and Taylor, 1970). Banks (1984) also describes a system as a group of objects that join together in some regular interaction or inter-dependence toward the accomplishment of some purpose. To attain the intended goal or to serve the desired function, it is necessary for the system to receive a set of inputs, to process them

correctly, and to produce the required outcomes. To sustain such flow, some control is required to govern system-behaviour.

Systems are of two types: the product system and the process system. A product system could be an automobile, a cellular phone, a computer, or a calculator. Any of these products involves the components of the system described above in terms of inputs, outputs, elements, relationships, controls, and goal. On the other hand, a process system can be a manufacturing process, an assembly line, a power plant, a business process such as banking operations, a logistic system, an educational system or emergency system. Similarly, any of these processes involves the system components defined in terms of inputs, outputs, elements, relationships, controls, and goal.

2.1.2 Modelling

Banks et al., 2000 defined a model as a representation of a system for the purpose of studying the system. The word *modelling* refers to the process of representing a system (a product or a process) with a model that is easier to understand than the actual model and less expensive to build (El-Haik and Al-Aomar, 2006). The system-representation in the model implies taking into account the components of the system. This includes representing the system's elements, relationships, goal, inputs, controls, and outputs. Modelling a system therefore has two prerequisites:

- Understanding the structure of the actual (real-world) system and the functionality and characteristics of each system-component and relationship. It is imperative to be familiar with a system before attempting to model it and to understand its purpose and functionality before attempting to establish a useful representation of its behaviour. For example, the modeller needs to be familiar with the production-system of building vehicles before attempting to model a

vehicle body-shape or a vehicle-assembly operation. Similarly, the modeller needs to be familiar with ED functionality and structure before attempting to model an emergency department.

- Being familiar with different modelling and system representation techniques and methods. This skill is essential to choose the appropriate modelling technique for representing the underlying real-world system. Due to budgetary and time constraints, the model selected should be practically and economically feasible as well as beneficial in meeting the ultimate goal of modelling. There are several model types as describe in following sub chapter that can be used to create a system model, and selection of the most feasible modelling method is a decision based on economy, attainability, and usefulness.

The modelling of a system of interest is a combination of art and science that is used for abstracting a real-world system into a hypothetical model. The model should be clear, comprehensive, and accurate so that the user can rely on its representation in understanding system functionality, analyzing its various postures, and predicting its future behaviour. From this perspective, system-modelling is the process of transferring the actual system into a model that can be used to replace the actual one for system analysis and system improvement.

2.1.3 Types of Model

El-Haik and Al-Aomar (2006) classify the system-modelling into four major categories: physical models, graphical models, mathematical models, and computer models. It is depicted in Figure 2.1 and the following gives a summary of each type of models.

Physical models are tangible prototypes of actual products or processes. Prototypes can use a 1:1 scale or any other feasible scale of choice. Such models provide a close-to-

reality direct representation of the actual system and can be used to demonstrate the system's structure, the role of each system-element, and the actual functionality of the system in a physical manner (El-Haik and Al-Aomar, 2006; Law 2000).

Graphical models are abstractions of actual products or processes using graphical tools. Common system graphical representations include a system-layout, flow-diagrams, block-diagrams, network-diagrams, process-maps, and operations-charts (El-Haik and Al-Aomar, 2006).

Mathematical modelling is the process of representing system behaviour with formulas or mathematical equations. They use mathematical equations, probabilistic models, and statistical methods to represent the fundamental relationships among system components. Design formulas for stress-strain analyses and mathematical programming models such as linear and goal programming are examples of mathematical models. Other examples include queuing-models, Markov chains, linear and nonlinear regression models, break-even analysis, forecasting models, and economic-order quantity models. Unfortunately, not all system responses can be modelled using mathematical formulas. The complexity of most real-world systems precludes the application of such models. Hence, a set of simplification assumptions must often accompany the application of mathematical models for the formulas to hold. Such assumptions often lead to impractical results that limit the chance of implementing or even, in some cases, considering such results (El-Haik and Al-Aomar, 2006; Law 2000).

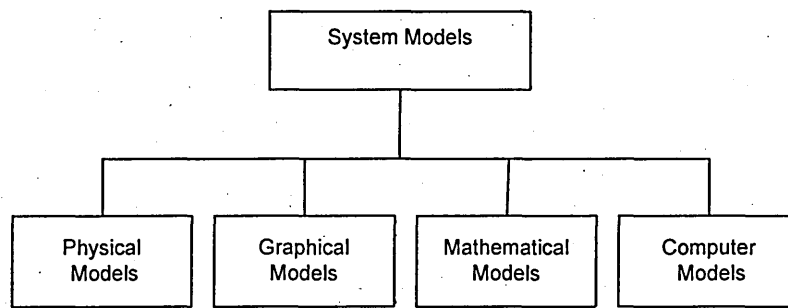

Figure 2.1 Types of System Models (El-Haik and Al-Aomar, 2006)

Computer models are numerical, graphical, and logical representations of a system that utilizes the capability of a computer in fast computations, with a large capacity, consistency, animation, and accuracy (El-Haik and Al-Aomar, 2006). Computer simulation models, which represent the middleware of modelling, are virtual representations of real-world products and processes on the computer. Computer simulations of products and processes are developed using different application programs and software tools. Accurate and well-built computer models compensate for the limitations of the other types of models. They are built using software tools, which is easier, faster, and cheaper than building physical models. In addition, the flexibility of computer models allows for quick changes, easy testing of what-ifs, and quick evaluation of system-performance for experimental design and optimization studies. Computer models also provide the benefits of graphical models with modern animation and logical presentation tools. Indeed, most computer models are built using graphical modelling tools. Compared to mathematical models, computer models are much more realistic and efficient. They utilize computer capabilities for more accurate approximations, they run complicated computations in little time, and they can measure system performance without the need for a closed-form definition of the system objective function. Such capabilities made computer models the most common modelling techniques in today's production and business applications.

A Discrete Event Simulation (DES) model is a computer model that mimics the dynamic behaviour of a real process as it evolves over time in order to visualize and quantitatively analyze its performance. The validated and verified model is then used to study the behaviour of the original process and then identify the ways for its improvement (scenarios) based on some improvement criteria. This type of computer model is the major focus in this research, where discrete event simulation is used as the main modelling tool to improve the efficiency in the emergency department of a hospital.

2.2 Simulation-modelling

This section focuses on defining the simulation concept and the taxonomy of various types of simulation-models. Simulation is a widely used term in reference to computer simulation models that represent a product or a process. The word simulation throughout this research also means computer simulation models. Such models are built based on both mathematical and logical relationships within the system structure. For example, finite element analysis is the mathematical basis for a camshaft product simulation model, and the operation of a factory is the logical design basis for a plant process model. In the context of this research, there are a number of definitions for simulation in the literature.

Simulation, according to Shannon (1975), is *“the process of designing a model of a real system and conducting experiments with this model for the purpose either of understanding the behaviour of the system or of evaluating various strategies (within the limits imposed by a criterion or set of criteria) for the operation of the system.”*

A definition for simulation is given by Kelton et al., (1998): "*Simulation refers to a broad collection of methods and applications which mimic the behaviour of real systems, usually on a computer with appropriate software*".

In one of the most quoted definitions of simulation, Banks (1998) defines it as "*the imitation of the operation of a real-world process or system over time. Simulation involves the generation of an artificial history of the system, and the observation of that artificial history to draw inferences concerning the operating characteristics of the real system that is represented*".

In general, system-simulation or simulation-modelling is the mimicking of the activity of the operation of a real system, in a computer, with a focus on process flow, logic, and dynamics. According to Pegden, Shannon, and Sadowski (1995), simulation-modelling is a methodology that enables the building of a model to study the temporal behaviour of a system and to evaluate different alternatives for its operation. In simplest form, simulation means making a simplified representation of an original. Just as a model aircraft captures many of the important physical features of a real aircraft, so a simulation model captures the important operational features of a real system. Therefore, instead of attempting to build extensive mathematical models by experts, simulation software tools have made it possible to model and analyze the operation of a real system by not only programmers, but also engineers and managers. This allows engineers to collect pertinent information about the behaviour of the system by executing a computerized model instead of observing the real one.

In conclusion, the primary requirements for simulation are a simulation analyst, a computer, and a simulation language or software tool. The analyst is the key player in conducting the simulation study. He or she is responsible for understanding the real-

world system and analyzing its elements, logic, inputs, outputs, and goals. The analyst then operates the computer system and uses the software tool to build, validate, and verify the simulation-model. Finally, the analyst analyzes the results obtained from running the simulation-model and conducts experimental designs with the model in order to draw conclusions on model behaviour and determine the best parameter settings. The Figure 2.2 describes the simulation study schematically.

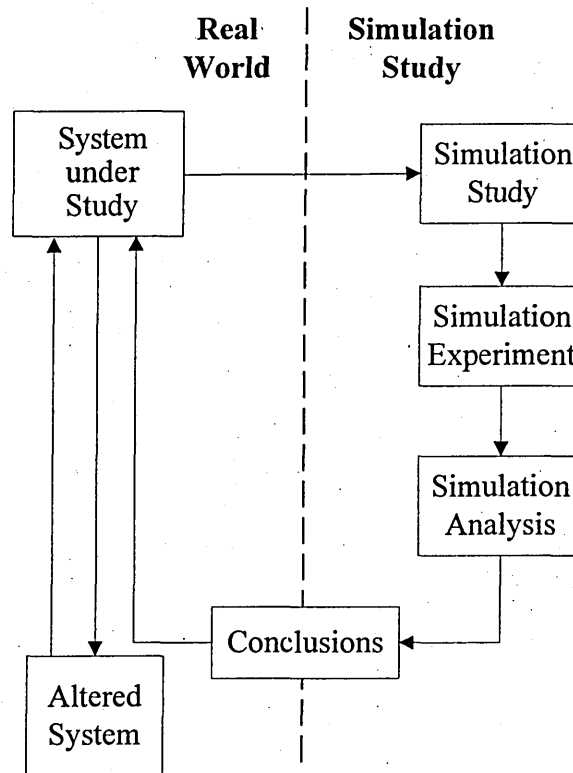

Figure 2.2 Schematic of a Simulation Study (Maria, 1997)

2.2.1 Types of Simulation-model

Based on the internal representation scheme selected, simulation-models can be discrete, continuous, or combined (El-Haik and Al-Aomar, 2006). Discrete-event simulation-models, which are the focus of this research, are the most common among simulation-types. DES models are based on a discrete internal representation of model variables that change their state at discrete points in time. In general, discrete

simulation-models focus on modelling discrete variables that are presented by random or probabilistic models, where the state of the system changes at discrete points in time. A discrete variable can be the number of customers in a bank, products and components in an assembly process, or cars in a drive-through restaurant.

Continuous simulation-models, on the other hand, focus on continuous variables, random or probabilistic, where the state of the system changes continuously. Examples of continuous variables include the level of water behind a dam, chemical processes in a petroleum refinery, and the flow of fluids in distribution-pipes. Combined simulation-models include both discrete and continuous elements. For example, separate (discrete) fluid containers travel in a chemical process where fluids are poured into a reservoir to be processed in a continuous manner (El-Haik and Al-Aomar 2006, Law 2000).

Furthermore, models are either deterministic or stochastic depending on whether they model randomness and uncertainty in a process or not. A stochastic process is a probabilistic model of a system that evolves randomly in time and space. Examples of stochastic models operating with random variables include inter-arrival times of customers arriving at a bank and service or processing times of customers' requests or transactions, variable cycle times, and machines' time to failure and time to repair parameters. Deterministic models, on the other hand, involve no random or probabilistic variables in their processes. Examples include modelling fixed-cycle-time operations, such as in the case of automated systems and arrivals with preset appointments to a doctor. The majority of real-world operations are probabilistic. Hence most simulation studies involve random generation and sampling from certain probability distributions to model key system variables.

Finally, and based on the nature of model evolution with time, models can be static or dynamic. In static models the system state does not change over time. For example, when a certain resource is always available in a manufacturing process, the state of such a resource is fixed with time. Every time this resource is required or needed, there will be no expected change in its status. Monte Carlo simulation-models are time-independent (static) models that deal with a system of fixed states. Most operational models are, however, dynamic. System state variables often change with time, and the interactions that result from such dynamic changes do affect the system behaviour. Hence, in DES simulation, the time dimension is live. This again makes DES models the most common among simulation types since they model variables that change their state at discrete points in time.

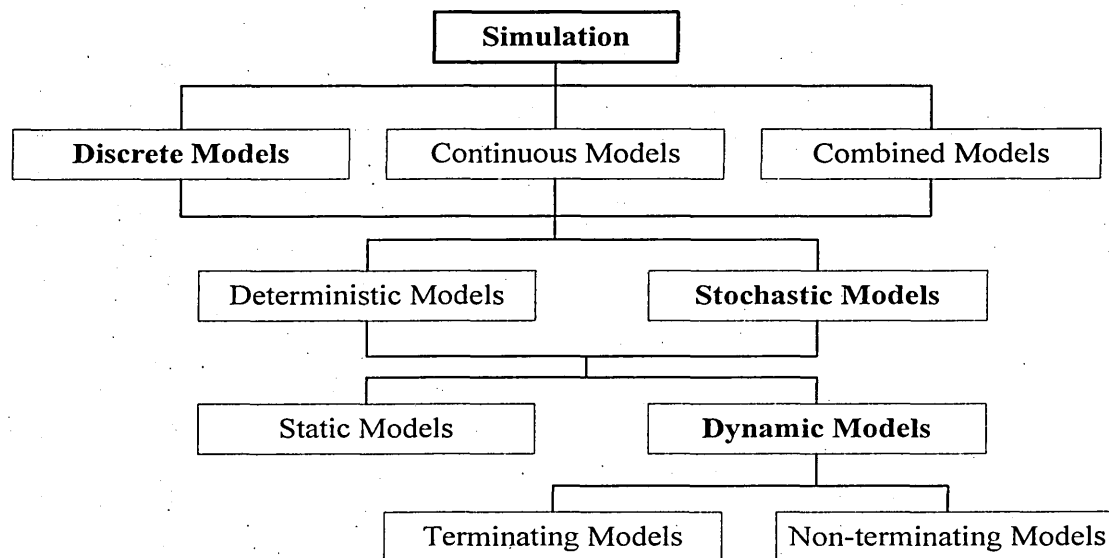

Figure 2.3 Simulation Taxonomy (El-Haik and Al-Aomar, 2006)

Dynamic simulation-models are further divided into terminating and non-terminating models based on run-time. Terminating models are stopped by a certain natural event, such as a doctor who sees a limited number of patients per day, a workshop that finishes all quantity in a certain order, or a bank that operates for 8 hours a day. In such systems,

the length of a simulation-run depends on the number of items processed, or on reaching a specified time-period, with the model terminating upon completion. Models that run for a specified period often include initial conditions such as cleaning the system, filling bank ATMs, resetting computers in a government office, or emptying boxes on an assembly line. Non-terminating models, on the other hand, can run continuously, since the impact of initialization is negligible over the long run and no natural event has been specified to stop them. Most plants run on a continuous mode, where production lines start every shift without emptying the system (El-Haik and Al-Aomar 2006, Law 2000).

As noted with highlighted attributes in the figure 2.3, DES models are discrete, stochastic, and dynamic computer-models of terminating or non-terminating response. These three characteristics often resemble the actual behaviour of many real-world systems and transactional processes. For example, in manufacturing systems, the flow of raw material, assembly components, and products can be modelled as discrete, dynamic, and stochastic processes. Many service-facilities including emergency departments also often deal with discrete entities that run dynamically in a stochastic manner.

2.3 The Role of Simulation

Simulation is one of the most widely-used analytical techniques adopted by professionals in Operations Research and Management Science (Law and Kelton, 1991). It has unique and powerful capabilities in system-representation and performance estimation and improvement. Simulation is often the analysts' refuge when other solution tools, such as mathematical models, fail or it becomes extremely difficult to approximate the solution to a certain problem. Most real-world processes in production and business systems are complex, stochastic, and highly non-linear and dynamic, which makes it almost impossible to present them using physical or mathematical models.

Analytical methods, such as queuing-systems, inventory models, and Markovian models, which are commonly used to analyze production and business systems, often fail to provide statistics on system-performance when real-world conditions intensify to overwhelm and exceed the system-approximating assumptions. Examples include entities whose arrival at service is not a Poisson process, and where the flow of entities is based on complex decision-rules under stochastic variability within availability of system-resources. Simulation-models are much more flexible and versatile. They are free from assumptions of the particular type of the arrival-process (Poisson or not), as well as the service-time (exponential or not). Simulation can be used for the combined random and non-random arrival-flow as well. The system-structure (flow-map) can be complex enough to reflect a real-system structure, and custom action logic can be built in to capture the real-system behaviour. Therefore, simulation is often used to model the complex, stochastic, and dynamic real-world problems that cannot be solved by other analytical models.

According to Carson II (2005), simulation is most useful in the following situations where:

1. There is no simple analytic model, spreadsheet model or “back of the envelope” calculation that is sufficiently accurate to analyze the situation.
2. The real-system is regularized; that is, it is not chaotic and out of control. System components can be defined and characterized and their interaction defined.
3. The real-system has some level of complexity, interaction or interdependence between various components, or pure size that makes it difficult to grasp in its entirety. In particular, it is difficult or impossible to predict the effect of proposed changes.

4. You are designing a new system, considering major changes in physical layout or operating-rules in an existing system, or being faced with new and different demand.
5. You are considering a large investment in a new or existing system, and it represents a system modification of a type for which you have little or no experience and hence face considerable risk.
6. You need a tool where all the people involved can agree on a set of assumptions, and then see (both statistically and with animation) the results and effects of those assumptions. That is, the simulation-process as well as the simulation-model can be used to get all members of a team onto a (more) common understanding.
7. Simulation with animation is an excellent training and educational device, for managers, supervisors, engineers and labour. In fact, in systems of large physical scale, the simulation animation may be the only way in which most participants can visualize how their work contributes to overall system success or creates problems for others.

The simulation has the capabilities that are unique and powerful in system-representation, performance-estimation, and improvement. A simulation-model is the most effective tool to perform quantitative 'what-if' analysis, and play different scenarios of the process behaviour as its conditions and variables change over time. Simulation provides a decision-support to the engineers and managers who want to make the best decisions possible, especially when encountering critical stages of design, expansion, or improvement projects in a real-system (El-Haik and Al-Aomar, 2006). The simulation-model allows one safely, rapidly and efficiently to study and assess the impact of new methods, strategies and/or technologies in the peri-operative and

operative process (Volkner and Werners, 2002). This simulation capability allows one to make experiments on the computer display, and to test different solutions (scenarios) for their effectiveness before going to the hospital floor for the actual implementation.

According to Banks et al. (2000), a few guidelines can be mentioned here however, namely that simulation should not be used if:

- the problem can be solved using common sense;
- the problem can be solved analytically;
- it is easier to perform direct experiments;
- the costs exceeds the savings;
- resources are not available;
- time is not available;
- data is not available;
- verification and validation cannot be performed;
- managers have unreasonable expectations;
- system behaviour is too complex, or cannot be defined.

2.3.1 The Advantages of Simulation

Based on Banks et al. (2000), Banks (2000), and Law and Kelton (1991), the advantages of simulation are here summarized as:

- **Cost:** It enables cost reductions and/or avoids costs.
- **Time:** It reduces ramp-up time of production and possibly development lead-time.
- **Complexity:** It enhances understanding of relationships, interactions, dependencies, etc.
- **Dynamics:** It captures time-dependent behaviour.

- **Replicability:** experiments can be repeated at any time.
- **Visualization:** It provides visual-analysis capabilities.

2.3.2 The Disadvantages of Simulation

According to Banks, Carson and Nelson (1996) the disadvantages of simulation are:

- **The need for special training:** building a simulation model is an art that is learned over time and through experience. Although simulation software may look simple, simulation requires a lot of work both before and after running the model.
- **The difficulties of interpreting the results:** Since most simulation outputs are random variables, it can be difficult to distinguish between system interrelationships and randomness in the results. In most cases, a significant amount of knowledge of statistical theory and methods is required.
- **Time and cost:** Modelling and analysis can take a lot of time and may be expensive. There is usually a clear trade-off between the resources allocated for modelling and analysis, and the quality of the resulting simulation-model in terms of how well it mimics reality.
- **Inappropriate use:** Simulation is sometimes used when an analytical solution would have been possible or even preferable, or in any of the other cases described previously (see Section 2.3).
- **Non-optimized results:** Simulation is not optimization, and even when near-optimal results are achieved, there is a risk of sub-optimization.

2.4 Steps in a Simulation Study

Simulation is a multi-stage process. Over the course of years, simulation experts have proposed different procedures for conducting simulation projects featuring a varying

number of steps (Law and Kelton (2000), Banks et al. (2000), Law and Kelton (1991), Shannon (1998), Pegden et al. (1995), Benjamin et al. (2000)). The steps in a simulation study may be varying in different studies because of factors such as the nature of the problem and the simulation software used (El-Haik and Al-Aomar, 2006). However, the building blocks of the simulation procedure are typically common among simulation studies. All of the above approaches to simulation-modelling consist of 10 to 12 steps which can also be grouped into three major generic phases; i.e. defining the simulation-problem, building the simulation-model, and conducting simulation experiments. Banks et al. (2000) introduced a set of steps to guide a model-builder in a thorough and sound simulation-study. His procedure is selected to present in this research, as one of the most quoted procedure in simulation literature. Twelve major steps involved with this approach are shown in Fig. 2.4 and their major tasks are briefly depicted below it. Similar figures and their interpretation can be found in other sources such as Pegden et al. (1995) and Law and Kelton (2000).

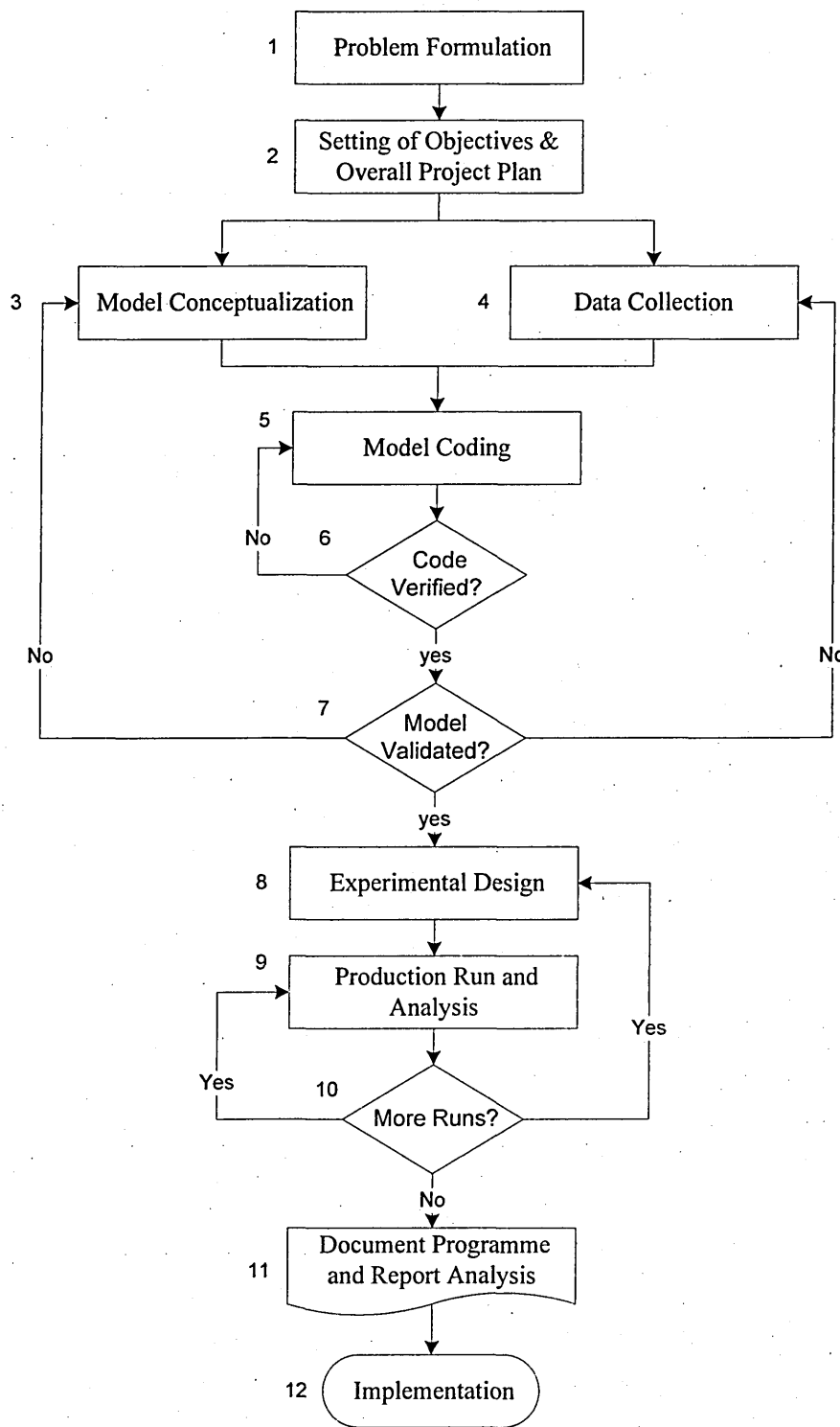

Figure 2.4 Steps in Simulation Projects (Banks, 2000)

1. **Problem Formulation:** Every simulation study begins with a statement of the problem prepared by either client or simulation analyst. If the statement is provided by the client, the simulation analyst must take extreme care to insure

- that the problem is clearly understood. If a problem statement is prepared by the simulation analyst, it is important that the client understand and agree with the formulation.
2. **Setting of Objectives and Overall Project Plan:** Here, the modeller establishes which tool should be used (e.g. a simulation or other analytical tool) as well as a set of assumptions. Also, the goals and definition of the project are defined, along with methods to evaluate the effectiveness of alternatives.
 3. **Model Building:** This refers to devising a conceptual model of the system under study. This means a more or less simplified, abstracted representation of the processes to be studied consisting of the essential components only.
 4. **Data Collection:** Data about the system is gathered if possible. If no data is available, rules of thumb or personal experience are used to approximate distributions. Data requirements may change as the model and its complexity progresses.
 5. **Coding:** Once the conceptual model is established and the data gathered, the conceptual model is translated into executable code, i.e. into the actual simulation program.
 6. **Verification:** This stage is necessary to assure the coded model does not contain any bugs and performs as expected and intended. If this verification fails, the code needs to be reviewed and corrected until it passes verification.
 7. **Validation:** Here, the focus is on verifying whether the model represents the system to be modelled with sufficient accuracy. If the model does not represent the behaviour of the real system with sufficient accuracy, the conceptual model and/or the data gathered needs to be reviewed.

8. **Experimental Design:** This involves designing the alternatives to be studied, along with the number of replications, the replication length and warm-up periods.
9. **Production Runs and Analysis:** This phase consists of running the experiments designed in the previous step and analysing the results thus obtained.
10. **More Runs?:** At this stage, the modeller has to verify whether the results obtained thus far are sufficient, or whether more runs or different experiments have to be run.
11. **Document Study and Reporting Results:** The results obtained from the simulation-runs, once analysed, have to be documented and reported/presented to the problem owner so that the results can be implemented in the actual system. This is also important if the simulation is to be reused and/or modified, especially if that will be done by another analyst.
12. **Implementation:** Depending on how well the previous steps have been conducted, the implementation of the results from the experiments will be more or less successful.

2.5 Simulation Software

Nowadays many simulation software-packages are available (ProcessModel, ProModel, Arena, Simul8, etc) which provide a user-friendly interface that makes the efforts of building a realistic simulation-model not more demanding than the efforts needed to make simplifications, adjustments and calibrations to develop a rather complex but approximate queuing-model.

There are periodic surveys, of which the most comprehensive is that conducted biennially by Swain (2007) which summarises the features available in simulation

packages, with no specific application area in mind. Currently, more than sixty different simulation software are available on the market from various vendors at different prices ranging from less than US\$99 up to US\$45,000 and almost all of them are PC-based and Windows-compatible (Swain, 2007).

The software to be used must be able to cope with both simulation-modelling process issues, as well as other conventional user and modeller requirements. Hlupic (2000) surveys academic and industrial simulation-software users. His surveys revealed that Simul8 and Witness are the two most commonly-used by academics and Witness is the most widely-used among participant industrial users. The survey also reveals that the most important features of software are ease of use, ease of communicating with other programming tools, and applications for building a user-interface. Abu-Taeh et al. (2007) have investigated 56 simulation-packages with the aim of tackling the trends that simulation packages are pursuing; and to address the issues around the prevalent technology.

2.6 Simulation Applications

Computer-simulation has existed for almost 40 years and has been used in every industry to study systems where there are resources at locations acting upon people or products (Nance and Sargen, 2002). Typical DES applications include: staff and production scheduling, capacity planning, productivity improvement, cycle time and cost reduction, throughput capability, resources and activities utilization, and bottleneck finding and analysis. A few examples of simulated-systems are manufacturing-plants, banks, airports, or business organizations (Ferrin, Miller, and Giron, 2000). Kuljis et al. (2007) also reported that discrete-event simulation has been used mainly for testing different strategies for increasing dispatch-bay productivity, reducing transport costs by

minimizing the waiting-times for vehicles, job-shop scheduling, logistics and operations in construction, and analysis of the construction inspection-process.

Simulation is being used for a wide range of applications in both manufacturing and business operations. According to El-Haik and Al-Aomar (2006), as a powerful tool, simulation-models of manufacturing systems are used:

- To determine the throughput capability of a manufacturing cell or assembly-line;
- To determine the number of operators in a labour-intensive assembly process;
- To determine the number of automated-guided vehicles in a complex material-handling system;
- To determine the number of carriers in an electrified monorail system;
- To determine the number of storage and retrieval machines in a complex automated storage and retrieval system;
- To determine the best ordering policies for an inventory-control system;
- To validate the production plan in material-requirement planning;
- To determine the optimal buffer sizes for work-in-progress products;
- To plan the capacity of sub-assemblies feeding a production mainline.

Simulation models are also being used for the following wide range of applications in business operations:

- To determine the number of bank-tellers, which results in reducing customer-waiting-time by a certain percentage;
- To design distribution and transportation networks to improve the performance of logistic and vending systems;
- To analyze a company's financial system;
- To design the operating policies in a fast-food restaurant to reduce customer

time-in-system and increase customer-satisfaction;

- To evaluate hard-ware and software requirements for a computer network;
- To design the operating policies in an emergency room to reduce patient-waiting-time and schedule the working-patterns of the medical staff;
- To assess the impact of government regulations on different public services at both the municipal and national level;
- To test the feasibility of product development processes and to evaluate their impact on a company's budget and competitive strategy;
- To design communication systems and data-transfer protocols.

2.7 Simulation in Healthcare

It is well-known that the use of modelling and simulation is widespread in business and manufacturing, and essential in the management of any type of organization. Over the last thirty years a growing number of studies have used simulation in modelling healthcare and ED performance. In the literature, two extensive reviews on the use of simulation in healthcare are found and both have been done until 1999 (Jun et al., 1999; Fone et al., 2003). Jun et al. (1999) surveys the application of simulations in healthcare over nearly a 30 year period, from 1960s to the late 1990s. They review 117 journal articles and classify them according to their objectives but only a few successful implementations are reported. Fone et al. (2003) also review more than a hundred papers related to the use of simulation-modelling in healthcare until 1999. Their review aimed to assess the quality of published studies and to consider their influence on policy rather than on operations. They opine that the quality of the papers has increased over the survey-period; however, few papers provide enough detail of model-implementation. Although the application of simulations has increased over the last three decades, simulation is still not widely accepted as a viable modelling-tool in

healthcare systems. Adriana (2000) reported that the healthcare industry has adopted simulation very slowly compared to other industries such as manufacturing. Eldabi et al. (2007) also report that the healthcare literature contains a large range of numerical and simulation techniques, but their application does not appear as widespread as in other sectors, which have long adopted such methods as part of their core operation, reaping significant benefits.

Jun et al. (1999) searched for studies of more complex, integrated and multi-facility systems and concluded that there seems to be a lack of such work reported in the literature. They suggest that the major reasons for this shortage are first, the level of complexity and resulting data requirements of the simulation model, and secondly, the resource-requirements including the time and money needed to conduct such research. They suggest that the main dilemma in such work is deciding on the appropriate level of detail. Increased detail leads to more realistic representation, which should increase the confidence of stakeholders. However, increased detail requires extensive, validated data and this may be expensive and time-consuming to collect. Washington and Khator (1997) state that the reason simulation-models are not used more often in healthcare settings is management's lack of incentive to do so. Management often does not realize the benefits to be gained considering the time and cost that have to be invested in order to build a detailed simulation-tool. To overcome the resistance against simulation, Lowery (1994) suggests that hospital management should be directly involved in the development of the simulation projects in order to build the model's credibility; and the use of visual aids or animation to create more confidence in the model's ability.

Gunal and Pidd (2005) conducted a study on performance assessment of the hospitals by using simulation and concluded that emergency departments and outpatient clinics are the most common studies in healthcare. They also note that there are no reported

uses of discrete-event-simulation for the development and improvement of health policy. Some researchers reported that simulation has been successfully used to model and analyze numerous emergency departments around the world (Mahapatra et al., 2003). Some other published material (Blasak, 2003 and Samaha, 2003) shows that emergency departments are utilizing simulation-modelling with the purpose of developing specific solutions tailored to resolving their respective issues. Gunal (2007) also reported that most simulation studies in the healthcare domain are aimed at solving specific problems in particular healthcare facilities. The commonalities in these studies are their objectives of improving performance such as reducing waiting-times or using resources more efficiently. Because they are specific, these studies guide a modeller as to how a specific problem can be solved.

This research includes a comprehensive literature survey of the use of simulation in healthcare from 1999 to early 2005 to fill the gap from 1999. 35 research papers that used simulation in healthcare were found from various journals and conference publications in this time-period. All of these papers are carefully reviewed and presented in Table 2.3 including the publisher, location of model in healthcare, software used and the aim/s of study. The table shows that simulation is used to model almost all the important areas in healthcare but the majority is used to model the emergency department and healthcare clinics. This review also revealed that simulation is used to model healthcare systems for different objectives such as performance improvement including waiting-time, resource-scheduling, capacity planning and utilization, and facility design. It further reveals that different modellers use different software-packages to model healthcare simulations. Arena has become the most popular software in modelling healthcare, while MedModel, Simul8 and Custom software also have been used in a significant number of studies.

Reference	Publisher	Location of Model	Software	Aim of Study
Rossetti et al. (1999)	Winter Simulation Conference	A&E	Arena	Scheduling and Staffing
Cahill and Render (1999)	Winter Simulation Conference	ICU	Arena	Bed-size planning
Lowery and Davies (1999)	Winter Simulation Conference	Operational theatre	MedModel	Scheduling
Weng and Houshmand (1999)	Winter Simulation Conference	Clinic	Arena	A new performance measure, cash-flow.
Alvarez and Centeno (1999)	Winter Simulation Conference	A&E	Arena	General
Ledlow et al. (1999)	Journal of Healthcare Management	Clinic	MedModel	Design
Lehaney et al. (1999)	Journal of the Operational Research Society	Dermatology Outpatient Clinic	Simul8	Waiting-times
Eldabi et al. (1999)	Computers & Industrial Engineering	Clinic	Simul8	Breast cancer treatment trial
Kim et al. (1999)	European Journal of Operational Research	ICU	XCELL+	Capacity-utilization
Bagust et al. (1999)	British Medical Journal (BMJ)	A&E	Excel	Waiting-times
Moreno et al. (2000)	Simulation (online)	Hospital	MODSIM Modula2	General
Alexopoulos et al. (2001)	Winter Simulation Conference	Clinic	Custom software	General
Kuljis et al. (2001)	Simulation	Generic Clinic	Custom software CLINSIM	General
Pulat et al. (2001)	Simulation (online)	Hospital	Arena	Bed-capacity planning
Swisher et al (2001)	Computers & Operations Research	Clinics	Custom Software (VSE)	General
Groothuis et al. (2001)	Comp. Methods and Programs in Biomedicine	Cardiac Dept.	MedModel	Capacity-planning

Ramis et al. (2002)	Winter Simulation Conference.	Laboratory	Arena + Excel	Standardize the service processes
Harper and Shahani (2002)	Journal of the Operational Research Society	Hospital	Custom Software TOCHSIM	Bed-capacity
Couchman et al (2002)	Simulation Modelling Practice & Theory	Biochemistry Laboratory	Simul8	Capacity-planning
Eleazer et al. (2003)	Winter Simulation Conference	Geriatric Department	ProModel	Length of Stay, Bed-size
Blasak et al. (2003)	Winter Simulation Conference	A&E	Arena	Waiting-time
Wong et al. (2003)	Winter Simulation Conference	Hospital	MedModel	Medication ordering and dispensing
Samaha et al. (2003)	Winter Simulation Conference	A&E	Arena	Bottlenecks and reducing waits
Baesler et al. (2003)	Winter Simulation Conference	A&E	Arena	Capacity-planning
Miller et al. (2003)	Winter Simulation Conference	A&E	Extend + Visio+ Access	Process improvements
Centeno et al. (2003)	Winter Simulation Conference	A&E	Arena	Staff-requirement scheduling
Harper and Gamlin (2003)	OR Spectrum	ENT Clinic	Simul8	Appointment Scheduling
Syi Sua, and Shihb (2003)	International Journal of Medical Inform.	A&E	eM-Plant	Emergency response policy
Guo, Wagner and West (2004)	Winter Simulation Conference	Outpatient Clinic	Arena	Appointment scheduling
Miller et al. (2004)	Winter Simulation Conference	A&E	Custom Software EDSim	General
Takakuwa and Shiozaki (2004)	Winter Simulation Conference	A&E	Arena	Patient-flows and Waiting-times,
Sinreich and, Marmor (2004)	Winter Simulation Conference	A&E	Custom Software	General (Generic A&E Model)
Baldwin, Eldabi, Paul (2004)	Simu. Modelling Practice and Theory	Clinic	Simul8	Liver transplantation

Griffiths et al. (2005)	Journal of the Operational Research Society	ICU	Simul8	Number of nurses and scheduling
Ashton et al. (2005)	Journal of the Operational Research Society	Walk in Centre	Micro Saint	Designing and planning operations
Rauner, Brailsford, Flessa (2005)	Journal of the Operational Research Society	Disease Prevention	Custom Software with (POST)	HIV prevention

Table 2.1 Use of Simulation in Healthcare in 1999-2005

After carefully studying all the above literature especially in ED (including reviews of Jun et al., 1999 and Fone at al., 2003), the researcher concludes that though growing numbers of studies use simulation in ED, it is still not widely-used as a decision-making tool in hospital emergency departments. Most of the simulation studies in ED have used simulation to model specific hospital EDs for specific purposes. Only a few studies have attempted to develop a generic and flexible model for any hospital ED but they also focus on only limited issues in ED. Therefore, there is a need to develop a holistic ED simulation study with comprehensive details to fill the vacuum in the literature.

2.8 The Importance of Simulation in Emergency Departments

Hospital-based emergency departments are critically important to the healthcare and wellbeing of the patients. They have become frequently crowded environments, with patients sometimes waiting hours and even days for care (Asplin et al., 2003). This has been recognized as a growing, complex and serious problem with no easy solutions for nearly two decades. Overcrowding in emergency departments presents a serious threat to the quality, safety and timeliness of emergency care.

The overcrowding and the resultant congestion due to the long waiting of patients in emergency departments are becoming increasingly widespread across the world. Increasing crowding and delays in emergency departments have been recognised as a growing problem throughout the developed world (Graff, 1999; Schafermeyer and Brent, 2003; Derlet et al., 2001). A 2001 American Hospital Association survey of emergency department and hospital capacity reported that 62% of the emergency departments were at or over operating capacity and one-third of ED had ambulance diversions (The Lewin Group, 2002). Derlet, Richards, and Kravitz (2001) surveyed ED directors in 50 states in the USA, and 91% of the 575 who responded reported ED crowding as a problem. A 2001 survey of ED medical directors in the state of Washington also revealed that 100% of large hospitals and 91% of small hospitals reported overcrowding problems (ACEP, 2002).

A BMA survey of A&E waiting times, (2005) also reported that 48% of emergency departments in the UK have not met their four hours waiting-time target for the period ending 31 December 2004. This problem in United States has been recognized since the early 1990s (Andrulis et al., 1991). Whereas in the early 1990s crowding was confined to large city hospitals, it has now become pervasive in community EDs (Derlet et al., 2001). According to Bradley (2005), overcrowding and long stay have been reported in the United States, United Kingdom, Australia, Canada, and Spain, demonstrating that this problem is not unique to the U.S. health care system. Kolb et al. (2008) also reported that emergency department overcrowding is a common medical-care issue in the United States and other developed nations. Shih et al. (1999) stated that overcrowding in one Taiwan hospital was so severe that 4% of admitted patients actually remained in the emergency department for four days or longer. Unfortunately, many EDs around the world are overcrowded on a daily basis (Cowan and Trzeciak,

2005; McCaig and Burt, 2004) and sometimes an ED stay can last up to eight hours because of crowding (Kowalezyk, 2007). According to this literature, it is very clear that overcrowding and long stays in emergency departments are a serious growing crisis in many countries throughout the world. Overcrowding in ED is multi-faceted and impacts on every aspect of emergency care.

Some hospitals try to alleviate the crowding by increasing additional capacity, staffing, or physical space. These extensive and generally costly approaches should not be tried until a hospital has fully evaluated and optimized the flow of patients through the ED and related units. Adding new capacity to an inefficient system may just create larger facilities that remain overcrowded. An efficient system assures maximum throughput and minimizes delays at each point along the delivery process, without any decline in the quality of care. Impaired patient-flow, on the other hand, results in bottlenecks that prolong delays for patients already in the process, as well as those awaiting entry into system.

There are a number of promising options that hospital administrators and policymakers have at their disposal to identify and resolve the problems that contribute to ED crowding and its consequences. Over the last few decades other industries have made use of a number of tools and techniques derived from engineering and operations research, which we collectively refer to as operations management. There are many operations management tools that could be applied to improve the management of the emergency department crowding crisis. Discrete-event simulation is a versatile tool among the modelling tools available to healthcare decision-makers that can assist in this endeavour.

Emergency departments are considered one of the most complex, interactive and dynamic systems to analyze. Similar to prescriptive models such as linear or nonlinear programming models, analytical models (queuing-models and Markov chains), which often rely on closed-form mathematical solutions, are very sensitive to the size, complexity and level of detail required by the system under study. Discrete-event simulation models, on the other hand, are much less sensitive to these parameters. The full power of simulation is realized when it is used to analyze dynamical systems with complex interactions among various components and processes (Law and Kelton, (2000). Therefore, discrete-event simulation is more suitable than analytical modelling solutions for complex systems like ED where the state of the system changes over time. Simulation models can provide a reasonable assessment of an ED's efficiency, resource needs, utilizations and other performance measures as changes are made in the different system-settings.

In the literature, a number of researchers have shown simulation as a valuable modelling tool to model the emergency department in a hospital. Davies and Davies (1994) reported that since EDs are large, complex, and highly dynamic, it is obvious that discrete-event simulation tools are particularly suitable for modelling them. Miller et al. (2004) stated that simulation is a powerful tool for hospitals to understand how much impact each process-improvement will have on their facility. Kuljis et al. (2007) also assert that there are many potential uses of discrete-event simulation in healthcare areas, such as logistics; patient-pathway design, re-engineering, and management; scheduling and queue-management; and the reduction of waiting-times. Rakich et al. (1991) also state that simulation can assist hospital management to develop and enhance their decision-making skills when evaluating different operational alternatives in order to improve existing EDs or to assist in designing and planning new ones.

The literature in this section reveals that even though simulation is one of most suitable tools for modelling ED it is not used as a viable tool to overcome the overcrowding problem in EDs. Therefore, there is a need to find how simulation can be used to overcome the overcrowding problem in EDs. In addition to simulation there are many other non-simulation systems tools that can be used in ED and healthcare. The next section briefly describes the more suitable non-simulation techniques and their application in healthcare and EDs.

2.9 Other Tools and Techniques

Over the last few decades, numerous tools and techniques have been developed by industrial engineers and operations researchers to manage manufacturing and service operations. In the past two decades a variety of modelling and non-modelling techniques from manufacturing and service operations have been come to healthcare. From them, the researcher has chosen two modelling tools (Queuing theory and System Dynamics) and two non-modelling tools (Balance Scorecards, Lean and Six Sigma) to analyse the possibility of supporting the ED decision-making other than by the discrete-event simulation which is the main focus of this research. The following gives a brief description of these methods. -

2.9.1 Queuing Theory

The literature on queuing theory goes back many decades and is included in the chapters of many text books (Taha, 2007 Bronson; Naadimuthu, 1997). Queuing theory is a mathematical modelling technique that is used to determine the capacity of services that are subject to variable demand over time. A queuing-model is based on the Poisson process and its companion exponential probability distribution with the underlying assumptions. It deals with problems that involve waiting (queuing) lines that form due

to the fact that resources are limited. It enables mathematical analysis of related processes, including arriving at the queue, waiting in the queue, and being served by the server(s) at the front of the queue. It also permits the derivation and calculation of several performance measures including the average waiting-time in the queue or the system, the expected number waiting or receiving service; and the probability of encountering the system in certain states, such as empty, full, having an available server or having to wait a certain time to be served.

Queuing theory has long been used for many decades in many industries such as banking and public transportation with the purpose of balancing customer service and resource limitations. Queuing theory models have had limited use in healthcare, but have been used to optimize scheduling and staffing in primary care, operating rooms, nursing homes, radiology departments and emergency departments (Gorunescu et al., 2002; Huang, 1995; Lucas et al., 2001; Murray and Berwick, 2003; Reinius et al., 2000; Siddharthan et al., 1996; McManus et al., 2004; Green et al., 2006).

2.9.2 System Dynamics

System dynamics (SD) is an analytical modelling methodology, the origins of which attributed to Forrester (1961) in his pioneering work on "industrial dynamics". Today, SD methodology is used beyond the industrial setting and has been applied in many different fields of study including health care (Dangerfield, 1999). System dynamics is defined as a methodology for mapping and then modelling the forces of change in any dynamically-complex system so that their influences on one another can be better understood, and the overall direction of the system can be better governed (Homer and Hirsch, 2006; Homer and Oliva, 2001). SD combines both qualitative and quantitative aspects and aims to enhance understanding of complex systems, to gain insights into system behavior. The qualitative aspect entails the construction of "causal maps" or

“influence diagrams” in which the system structure and the interrelations between the components of a system are explored. The quantitative aspect entails the development of a computer model in which flows of material or information around the system are modelled and bottlenecks identified. Such models can then be used in a “what if” mode to experiment with alternative configurations, flows, and resources. In the health care context, this entails modelling patient pathways, information flow, and resource use.

With nearly a 50 year history, SD modelling today is used productively in many fields of human endeavour (Roberts, 1999; Sterman, 2000). The span of applications has grown extensively and now encompasses work in corporate management (Repenning and Sterman, 2001); climate change (Sterman and Sweeney, 2002); urban development (Forrester, 1969); energy and global ecology (Meadows, 2004); human service delivery (Levin and Roberts, 1976); education (Saposnick, 2004); and more.

Since the 1970s, and increasingly today, innovative investigators have used SD modelling to better understand some of the problems that health leaders face (Milstein, 2006). Some significant examples include studies of healthcare problems such as healthcare reform (Hirsch et al., 2005); patient-flows (Lane et al., 2000; Wolstenholme, 1999); performance-assessment (McDonnell, et al., 2004); public health emergencies (Hirsch, 2004; Hoard et al., 2005); public health planning (Hirsch and Immediato, 1999; Homer and Milstein, 2004).

2.9.3 Balanced Scorecards

The Balanced Score Cards (BSC) is a strategic measurement and management system initially developed by Robert Kaplan and David Norton at the Harvard Business School (Kaplan and Norton, 1996). It is used extensively in business and industry, government, and non-profit organizations worldwide to align business activities to the vision and

strategy of the organization; and to improve internal and external communications, and monitor organization performance against strategic goals. It translates an organization's mission and strategy into a balanced set of integrated performance-measures.

The balanced scorecard has evolved from its early use as a simple performance measurement framework to a full strategic planning and management system. The "new" balanced scorecard transforms an organization's strategic plan from an attractive but passive document into the "marching orders" for the organization on a daily basis. It provides a framework that not only provides performance-measurements, but helps planners identify what should be done and measured. It enables executives to truly execute their strategies. The balanced scorecard suggests that it views the organization from four perspectives, and can develop metrics and collect data and analyze it relative to each of these perspectives: the Learning & Growth Perspective, the Business Process Perspective, the Customer Perspective and the Financial Perspective.

Tian and Bruce (2006) have analyzed 22 BSC in healthcare examples: 10 were from United States of America, 3 each from the United Kingdom and Sweden respectively, 2 each from Australia and New Zealand, and one each from Canada and Taiwan. According to this analysis, 17 of them were used as a strategic management tool and the rest were used as a performance management tool. Although many successful stories of using balanced scorecards have been reported in other industries and service organizations, little evidence of their application to hospitals has been reported (Chow and et al, 1998). Nevertheless, there is a strong consensus among prominent researchers from many countries about the need to use balanced scorecard reporting by healthcare providers (Forgione, 1998). Although the BSC has been applied successfully as a strategic management tool, there is also evidence of many failures. Neely and Bourne (2000) claim a failure rate of 70%. In healthcare, much of the literature relates

to how to apply BSC successfully (for example, Chow, Ganulin et al., 1998; Stewart and Bestor, 2000; Pink, Oliveira, 2001; Fitzpatrick, 2002; Shutt, 2003; Tarantino, 2003; and Radnor and Lovell, 2003).

2.9.4 The Lean and Six Sigma

Lean is an effective business improvement methodology that is commonly used in manufacturing (George, 2005, 2003). Lean principles come from the Japanese manufacturing industry. It started with Toyota in the 1950s and was developed by Womack and Jones (Womack, 1996). Lean means “using less to do more” by “determining the value of any given process by distinguishing value-added steps from non-value-added and eliminating waste so that ultimately every step adds value to the process” (Miller, 2005). It seeks to provide what the customer wants quickly, efficiently, and with little waste.

The goals of the Lean Business Improvement method are to make better business decisions through intimate knowledge about the customer, intimate knowledge about the process, with data and the right people involved. Waste is defined as work, time, or supplies used to provide a service that adds no value in the eyes of the customer. Waste can be in many forms: time, motion, transportation, inefficient work-flows, deficient supplies, re-work, handoffs, and process-variation. The core data in Lean are derived from process and work-flow maps that are “time-mapped” (measuring the time spent at each particular activity in the workflow) and then “time-value stream” mapped (defining if each particular activity in the workflow is value-added or non-value-added work in the eyes of the patient). These principles have been applied to hospital services delivery and have been reported to be highly successful in the ED setting and the inpatient setting in case-reports in peer-reviewed journals (Aldarrab, 2006; Fairbanks, 2007; de Koning et al., 2006; and Sunyog, 2004).

The Six Sigma method of business management also comes from Japanese manufacturing industry (Caldwell C. et al. 2005; and Brassard M. and Ritter D., 2002). Six Sigma was developed by Motorola in the late 1970s as a universal system to assess quality, produce quantifiable results, and establish quality goals (Harry and Schroeder, 1999). Six Sigma goes after specific opportunities to eliminate defects, to improve quality, and to reduce costs. The Six Sigma method recognizes that variability hinders the ability to deliver high quality service reliably. It tools associates with advanced, powerful statistics. Six Sigma involves data-driven decision-making, using all of the traditional tools of quality, a cadre of Six Sigma tools, all the tools of Lean, and, as routine, complex statistical analytical methods to find major solutions to big problems. Lean is now often a module within Six Sigma training programs.

Integrating Lean and Six Sigma creates a “Win-win” situation. A combination of both can provide the philosophy and the effective tools to solve problems and create rapid transformational improvement at lower cost. Potentially, this could increase productivity, improve quality, reduce costs, improve speed, create a safer environment for patients and staff and exceed customer expectations (Bevan et al., 2005). Therefore, these methods may have the potential to improve both the efficiency and quality of care-delivery systems.

2.10 Modelling-based Frameworks in Healthcare

As discussed in the above sub-chapters, simulation and other systems tools have been successfully used to address operational problems in Emergency Departments and Healthcare systems in general. However, in all the reported cases, modelling tools have been used to address specific issues in isolation. To date, no work has been reported on the development of a comprehensive and holistic framework which enables the use of modelling tools across all decision-making processes, from strategic to operational. More recently, a collaborative project between Brunel, Cambridge, Southampton and Ulster universities, has identified the need for a comprehensive framework to embed and integrate modelling tools (Eldabi and Young, 2007b). These authors reported that the changing needs of Healthcare provision around the world are forcing service designers and decision-makers to adopt new tools in the design and evaluation of processes. (Reid et al. 2005) also reports the need for an integrated framework based on a partnership between engineers and Healthcare professionals. They suggest systems-engineering tools and information technologies have the potential of improving radically the quality and productivity of American Healthcare. Harper and Pitt (2004) also emphasised that careful thought should be given to selecting the appropriate modelling tools, and successful projects should be promoted to a wider Healthcare audience.

Although the above authors have identified the need for a comprehensive framework to embed modelling tools in the decision-making process, to date, no work has been done to develop such a framework. Therefore the proposed research work is timely and novel.

2.11 Summary

In the past few decades a variety of modelling and non-modelling tools and techniques from manufacturing and service operations have been approached to the healthcare sector. Among them, discrete-event simulation is one of the most important tools available to engineers as well as to managers to analyze the behaviour of large, complex and dynamic systems. Although over the last thirty years a growing number of studies have used modelling and simulation in healthcare and emergency departments, simulation is still not widely accepted as a viable modelling tool in decision-making in health and emergency care systems. The emergency department is the most important, complex, and highly dynamic part of the health and emergency care system. Over the last two decades, the overcrowding and delay in the emergency department has become a growing, complex and serious problem in many developed countries with no easy solutions. Over nearly three decades, computer simulation also has been used to address the various problems in healthcare and emergency departments including overcrowding and long waiting-time problem. Most of the simulation studies in ED have used simulation to model specific hospital EDs for specific purposes with limited details. Only a few studies have attempted to develop a generic and flexible model for any hospital ED but they also focused on only limited issues in the overcrowding problem. Therefore, there is a great need to develop a holistic and embedded ED modelling and simulation study that provides a sufficiently comprehensive and detailed framework for the simulation-model builders in ED as well as for the Healthcare and ED Managers to overcome this overcrowding problem.

CHAPTER THREE

3. Research Methodology

The previous chapter presented the underlying theoretical concepts of this research. This chapter describes the research methodology adopted throughout this research. For any kind of research, the theory on which that research rests obviously becomes very relevant. However, there is not one single theory or methodology of research, but rather a set of theories and methodologies that have evolved over time. Therefore, there is no universal right or wrong choice of research methodology: it is always possible to argue for or against a particular theory of science based on one's own subjective opinions. Therefore, it is necessary to justify the adopted research methodology to answer this particular research problem. This chapter attempts to explain the research approach and strategy including the type and methods of this research.

3.1 Research Approach

In research methodology literature, mainly there are two research approaches: the deductive approach (deduction) and the inductive approach (induction). The choice between the deductive or inductive research paradigms has been discussed by a number of authors (Cavaye, 1996; Hussey and Hussey, 1997; Saunders et al., 2006; Gilbert, 1993).

According to Gilbert, (1993) the process of working through a single case and observing a relationship, then observing the same relationship in several more cases and finally constructing a general theory to cover all the cases, is known as induction. It is the basic technique for moving from a set of observations to a theory and is illustrated in Figure 3.1. Induction is the dominant approach in social research. Once a theory has

been formulated, it can be used to explain. The process, starting with a theory and using it to explain particular observations, is known as deduction and illustrated in Figure 3.2. Deduction takes the data about a particular case and applies the general theory in order to deduce an explanation for the data. The deductive approach is generally considered as scientific research. Hence, it is the dominant approach in the natural sciences, where the laws provide the basis of explanation and predict their occurrence. Thus induction is the technique for generating theories and deduction is the technique for applying them. Table 3.1 further distinguishes these two approaches.

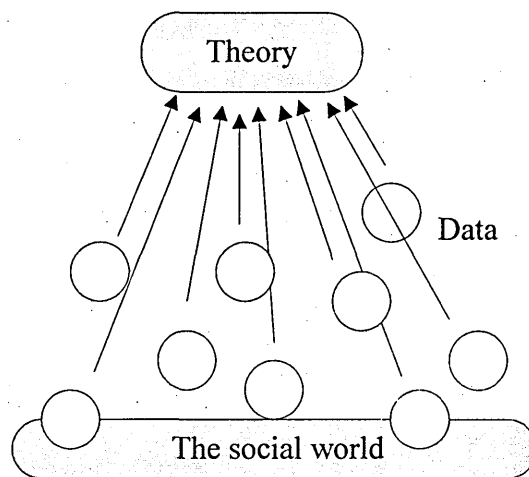

Figure 3.1 Induction Approach

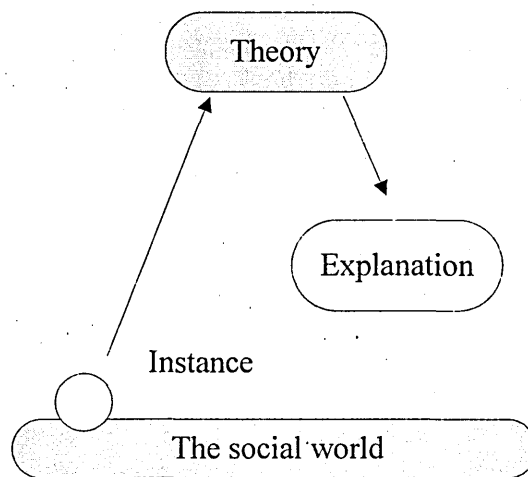

Figure 3.2 Deduction Approach

Elements of the Deductive Approach	Elements of the Inductive Approach
<p>This approach:</p> <ul style="list-style-type: none"> ○ Involves an understanding of scientific principles ○ Moves from theory to data ○ Explains causal relationships between variables ○ Generates and uses quantitative data ○ Involves a highly structured approach ○ Exhibits a high concern about generalization ○ Encourages researcher independence in what is being researched ○ Requires samples of sufficient size ○ Involves common research strategies: experiments, surveys 	<p>This approach:</p> <ul style="list-style-type: none"> ○ Involves an understanding of humans' attachment to events ○ Moves from data to theory ○ Explains by understanding ○ Generates and uses qualitative data ○ Uses a more flexible structure to permit changes ○ Exhibits less concern about generalization ○ Involves the researcher as part of the research process ○ Uses common research strategies: surveys, Grounded Theory, case studies, Action Research

Table 3.1 Induction Approach versus Deduction Approach

However, Saunders et al. (2006) and Gilbert (1993) emphasize that a clear adoption of one approach to a particular research project is impossible in reality. They recommend that the combination of the two approaches to research is often advantageous. This research also required the adoption of both these approaches to achieve the multiple objective of the research. As explained above, deductive reasoning works from the more general to the more specific. The deductive approach is most suitable for the first part of this research. The first part of the research deals with existing theory to explain

particular observations. The overcrowding in ED is an existing general theory. The first part of the research investigates and identifies the causes and effects of the overcrowding and accordingly develops a decisions-framework for the ED. That process is a deductive approach. The final part of the research attempts to identify the most suitable tool or set of tools for the ED decision-making to manage the overcrowding problem. This process is carried out by identifying and analysing many successful cases and applications to derive a general conclusion. This process moves from specific observations to broader generalizations. Thus it is an inductive approach. Therefore, both these approaches are used to achieve the aim of this research. The next section elaborates on the research strategies and methods used in this research.

3.2 Research Strategy

In the research methodology literature, many research strategies are described by different authors. The selecting of the appropriate research strategy or strategies depends on the purpose of the research. According to the purpose of research, there are three types of researches: exploratory, descriptive and explanatory (Saunders et al. 2006). An exploratory study is a valuable means of finding out 'what is happening; to seek new insights; to ask questions and to assess phenomena in a new light' (Robson, 2002). It is particularly useful if the researcher wishes to clarify the understanding of a problem, for instance, if the precise nature of the problem is unsure. Descriptive research, also known as statistical research, describes data and characteristics about the population or phenomenon being studied. It is necessary to have a clear picture of the phenomenon on which the researcher wishes to collect data prior to the collection of the data. This may be an extension of, or a forerunner to, a piece of exploratory research or, more often, a piece of explanatory research. The studies that establish causal relationships between variables may be termed explanatory research. The emphasis of

explanatory research is on studying a situation or a problem in order to explain the relationships between variables.

According to the nature and objectives of this research, the researcher believes the exploratory type study is more suitable for this research and the strategies of research are selected accordingly. Saunders et al. (2006) describe three principal ways of conducting exploratory research: a search of the literature; interviewing 'experts' in the subject; conducting focus group interviews.

According to Yin (2003) and Saunders et al (2006), there are many research strategies which can be used for exploratory, descriptive and explanatory research. The most common research strategies are:

- Experiment;
- Survey;
- Case Study;
- Action Research;
- Grounded Theory;
- Modelling;
- Ethnography;
- Archival Research.

Some of strategies clearly belong to the deductive approach, others to the inductive approach. However, allocating strategies to one approach or the other is often unduly simplistic. Saunders et al. (2006) emphasize that no research strategy is inherently superior or inferior to any other. Consequently, what is most important is not the label that is attached to a particular strategy, but whether it will be able to answer the particular research question and/or meet research objectives. So, the choice of research

strategy will be guided by research question(s) and objectives, the extent of existing knowledge, the amount of time and other resources which are available, as well as the researcher's own philosophical underpinnings.

The goal of this research is to develop a modelling-based framework to overcome the overcrowding problem in Emergency Departments. To achieve this goal, the research has set multiple objectives as explained in Chapter One. Overcrowding in ED is a very complex interaction with people, facilities, technologies, processes and many other sub-systems. In order to address this problem, it is necessary to understand the overcrowding problem, ED operations and its decisions as well as the available tools and techniques. After studying all these factors it develops a holistic-level decisions-framework for ED and then identify the most suitable tool or set of tools to support each decision to overcome the overcrowding problem.

The nature of this research process is highly qualitative rather than quantitative. Qualitative research is a field of inquiry applicable to many disciplines and subject-matters. Qualitative researchers aim to gather an in-depth understanding of human behaviour and the reasons that govern such behaviour. The qualitative method investigates the why and how of decision-making, not just what, where, and when. Quantitative research is the systematic scientific investigation of quantitative properties and phenomena and their relationships (Wikipedia, 2009). The objective of quantitative research is to develop and employ mathematical models, theories and/or hypotheses pertaining to natural phenomena.

According to Patton (1990) qualitative research methods permit the evaluator to study selected issues in depth and detail. Approaching fieldwork without being constrained by predetermined categories of analysis contributes to the depth, openness, and detail of

qualitative inquiry. Qualitative research is multi-method in its focus, involving an interpretive, naturalistic approach to its subject-matter (Denzin and Lincoln 1998). This means that qualitative researchers study things in their natural settings, attempting to make sense of, or interpret, phenomena in terms of the meaning people bring to them. Qualitative research is interpretive, observational and historical; it involves the studied use and collection of a variety of empirical case-studies, personal experiences, in-depth interviews, visual texts that describe routine, problematic moments and meanings in individual's lives, and much more. In this context the researcher selected multiple strategies i.e. grounded theory, case study analysis, stakeholder interviews, and literature reviews to answer this research problem. The following describes these strategies in brief.

3.2.1 Grounded Theory

Grounded Theory is often thought as one of the best examples of the inductive approach and it can be used to explore a wide range of business and management issues (Saunders et al 2006). In Grounded Theory, data collection starts without formation of an initial theoretical framework. A theory is developed from analysis of data generated by a series of observations. Qualitative analysis on data gathered is conducted in a general sense in a less formalised or procedural way. Such a data-analysis leads to the generation of predictions that are then tested by further observations which may confirm, or otherwise, the predictions. This research involves well-established theories and practices in the discrete-event simulation and other alternative non-simulation techniques where facts and observations are well-recorded. Grounded Theory is not presentation of raw data. It is essential that the data collected are considered at a conceptual level in order to draw conclusions which contain theoretical insights. Therefore, Grounded Theory strategy is more justifiable for gathering data and

information in this research, as it makes provision for the researcher to compare the data and concepts used constantly to aid the process of developing the decision-framework in the context of this research.

3.2.2 Case-study Analysis

The case-study as a research strategy has been explored by a number of authors (Cavaye, 1996, Darke et al., 1998). Case-studies are defined in various ways and a standard does not exist. However, a definition may be compiled from a number of sources (Benbasat, 1987; Yin, 2003). Yin (2003), for example, defined a case-study as 'an empirical inquiry that investigates a contemporary phenomenon within its real-life context'. Robson (2002) also defines a case-study as 'a strategy for doing research which involves an empirical investigation of a particular contemporary phenomenon within its real-life context using multiple sources of evidence'.

The case-study approach is multi-faceted and may be applied and used in a number of different ways (Cavaye, 1996). Case studies can be undertaken from a positivist or interpretivist paradigm, may be deductive or inductive, may involve single or multiple cases using literal or theoretical replication and may use qualitative and quantitative data (Shanks and Parr, 2003). The case-study strategy will be of particular interest if the researcher wishes to gain a rich understanding of the context of the research and the processes being enacted (Morris and Wood, 1991). The case-study strategy also has considerable ability to generate answers to the question 'why?' as well as the 'what?' and 'how?' questions, although 'what?' and 'how?' questions tend to be more the concern of the survey strategy. For this reason the case-study strategy is most often used in explanatory and exploratory research.

This research uses multiple case-studies for its research purpose. To understand the complexity of the patient-flows in the emergency departments it studied the patient-flows of the Sheffield Children's Hospital as a single case study. It also uses a large number of published cases where simulation or other selected systems-tools have been successfully applied in Emergency Departments or any other similar healthcare operations from all over the world. These successful multiple cases in literature are analysed to justify the suitability of selected tools and techniques to support the given ED decisions in the framework developed in this research.

3.2.3 Stakeholder Interviews

An interview is a purposeful discussion between two or more people (Kahn and Cannell, 1957). Interviews can be used to gather valid and reliable data that are relevant to the research question(s) and objectives. According to Saunders et al. (2006), basically, there are three types of research interviews: structured, semi-structured and unstructured interviews.

Structured interviews are conducted using questionnaires based on a predetermined and identical set of questions. As structured interviews are used to collect quantifiable data, they are also referred to as 'quantitative research interviews'. Structured interviews are normally used in descriptive studies to identify general patterns. They are also used to gather data, which will then be the subject of quantitative analysis, for example as part of a survey strategy. Structured interviews may also be used in relation to an explanatory study, in a statistical sense.

In semi-structured interviews, the researcher has a list of themes and questions to be covered, although these may vary from interview to interview. This means that the interviewer may omit some questions in particular interviews, given a specific

organizational context that is encountered in relation to the research topic. The order of questions may also be varied depending on the flow of the conversation. Semi-structured interviews are used in explanatory studies in order to understand the relationships between variables, such as those revealed from a descriptive study. Semi-structured interviews may also be used in relation to an exploratory study.

Unstructured interviews are informal. Researchers use methods to explore in depth a general area in which they are interested. There is no predetermined list of questions to work through in this situation, although the researcher needs to have a clear idea about the aspect or aspects that he wants to explore. Normally, unstructured interviews are very helpful in an exploratory study, to 'find out what is happening and to seek new insights' (Robson, 2002). Unstructured interviews are used to gather data, which are normally analyzed qualitatively.

In this research, semi-structured and unstructured interviews were conducted as a method of some data and information collection in the ED decision-framework development process. The researcher conducted semi-structured interviews with the key informants in the selected hospitals in England. The hospitals were selected using a simple random sampling method. For convenience the researcher mainly selected three hospitals that were close to the researcher's living area. These three hospitals were Sheffield Northern General Hospital, Chesterfield Hospital, and Sheffield Children's Hospital. The researcher regularly visited the Emergency Departments of these hospitals and conducted semi-structured interviews with ED managers, nurse managers and ED consultants to get the relevant information and clarification at the various stages in the development of the ED decision-framework. The semi-structured interviews were also conducted with these key informants for the validation of the framework and the decisions selected for the framework. At the same time, in those visits the researcher

had an opportunity to conduct unstructured interviews with other stakeholders such as patients, doctors and nurses to get further information and a clear picture of the ED issues.

3.3 The Development of the Framework

The development of the modelling-based framework is spread throughout this research. Based on the analysis and findings through the above-mentioned research strategies, the researcher developed the framework to answer this research problem. In the first part of the research, the researcher attempted to get full awareness of the Emergency Department's operations and its current issues. Then, the researcher analysed the overcrowding problem in ED and found the causes of the overcrowding problem. Based on the causes of the overcrowding problem, the researcher developed a two-dimensional decisions-frame to address this overcrowding problem. In the final part of this research, the researcher identifies best possible tools to support the decisions in this framework based on the successful cases and applications in healthcare. Taken as a whole, this work provides a comprehensive and holistic framework to ED managers and policy-makers to overcome the overcrowding problem in EDs.

3.4 Summary

This chapter described the methodology adopted in this research including the research approaches and strategies as well as the research type and methods. The whole methodology and process of this research are depicted in Figure 3.2. The multiple objectives of this research required both deductive and inductive approaches. The researcher has chosen three research strategies to achieve the objectives of this research. Those strategies are: Grounded Theory, case-study analysis, and stakeholder interviews.

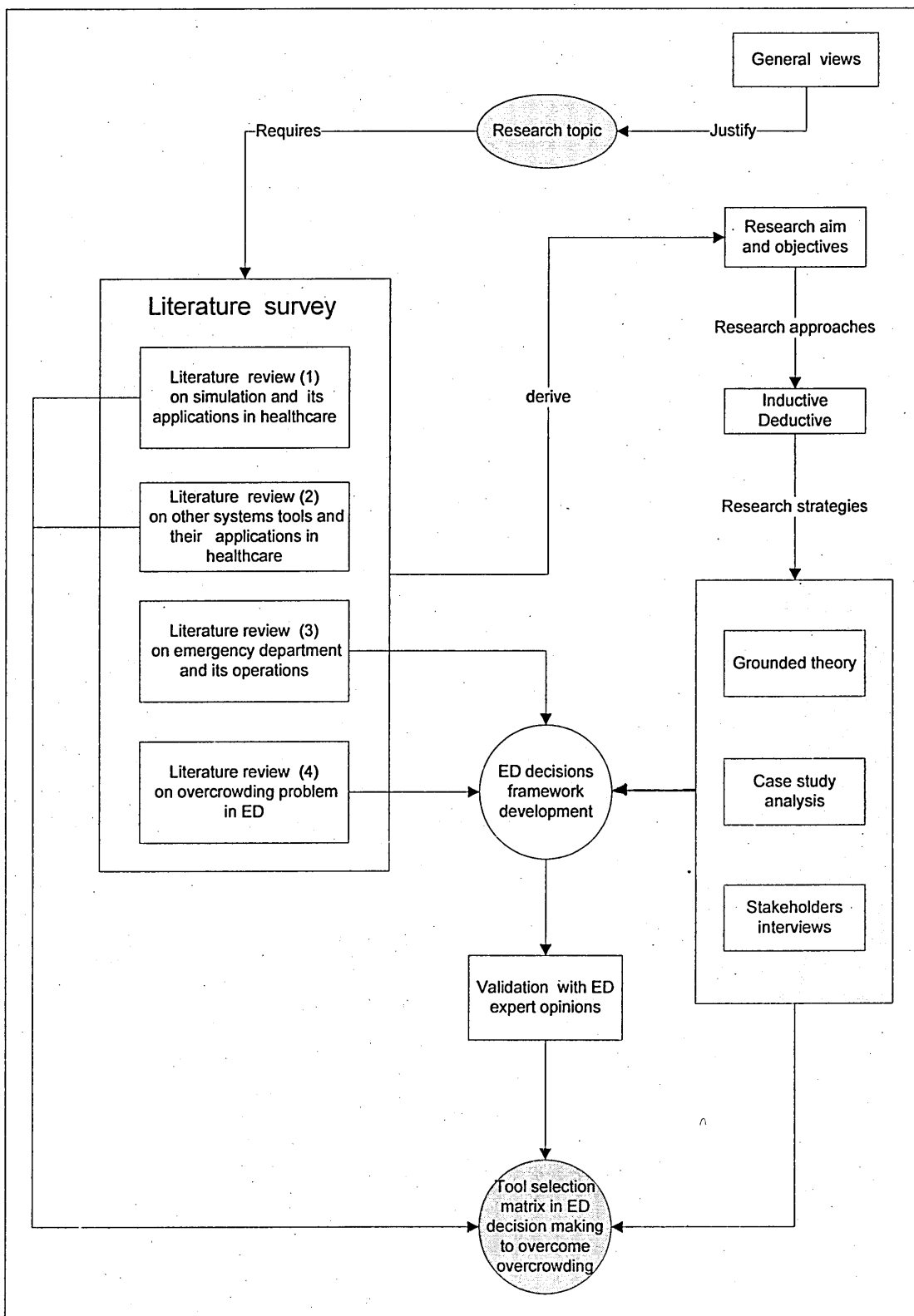

Figure 3.3 The Research Methodology and Process

CHAPTER FOUR

4. An Overview of the Emergency Department in Hospitals

The previous chapter described the methodology adopted in this research. It is necessary to study the Emergency Department and its operations before attempting to address the research problem explained in Chapter One. Therefore, this chapter attempts to give an overview of the Emergency Department in hospitals and its operations. First, it gives a general introduction about emergency-care including the ED function, resources and processes. Then, it briefly describes the Emergency Departments in England. Finally, it studies the patients' flow in the Emergency Department in Sheffield Children's Hospital.

4.1 Emergency Department of Hospitals

Emergency-care encompasses the full continuum of services involved in emergency medical care, hospital-based Emergency Department and trauma care, on-call specialty care, and all other pre-hospital emergency medical services. The Commission for Healthcare Audit and Inspection (2008) uses the term 'emergency care' to describe the care provided by a number of important services; and this ranges from lifesaving treatment for people who suffer strokes, heart attacks or other serious medical conditions, to providing treatment and support to people with an urgent need for care or reassurance. The Emergency-care System refers to the organized delivery-system for emergency-care within a specified geographic area. The Emergency Department is the hub of the Emergency-care System.

The Emergency Department, sometimes termed the Emergency Room (ER), Emergency Ward (EW), Accident & Emergency (A&E) Department or Casualty Department is a department in a hospital that provides initial treatment to patients with a broad spectrum of illnesses and injuries, some of which may be life-threatening and require immediate attention. The abbreviation ER is generally used throughout the United States, while A&E is used in the UK including many Commonwealth nations. ED is preferred in Canada and Australia. In this research the abbreviation ED is used for Emergency Department throughout the research.

The Emergency Department is the dedicated area in a hospital that is organised and administered to provide a high standard of emergency-care to those in the community who perceive the need for, or are in need of, acute or urgent care, including hospital admission (Australasian College of Emergency Medicine, 2009). EDs must meet an uncertain demand from patients, some of whom can be treated within the Emergency Department, others of whom are admitted to the hospital for further treatment as inpatients. The performance of the EDs affects the patients they serve and also the rest of the Emergency-care System.

The emergence of the modern Emergency Department is a surprisingly recent development. According to The National Academy of Sciences (2006), prior to the 1960s Emergency Rooms were often poorly equipped, understaffed, unsupervised, and largely ignored. At that time in many hospitals in the US, the Emergency Room was a single room staffed by nurses and physicians with little or no training in the treatment of injuries (The National Academy of Sciences, 2006). Over four decades, the hospital Emergency Department has been transformed into a highly effective setting for urgent and lifesaving care, as well as a core provider of ambulatory care. An extraordinary range of capabilities converge in the ED: highly-trained emergency providers, the latest

imaging and therapeutic technologies, and highly-trained on-call specialists in almost any field are all available 24 hours a day, 7 days a week.

Increasingly Emergency Departments are organised in similar ways in the USA, Canada, Australia and New Zealand, but the systems in Europe are very different. The former have a specialty of Emergency Medicine and these specialists are the first contact for many patients presenting with emergencies to hospital. European systems rapidly triage patients to inpatient specialties for care and have a wider system of community facilities for those with less severe conditions. Britain has more similarities with the non-European systems except it has traditionally undertaken less extensive investigation of complex medical problems, although this is changing with time. The organisation of the whole Emergency-care System is different in all these countries. Therefore it can be difficult to extrapolate changes in one system to another system. But the purpose of ED is similar among all the countries. All EDs are primarily established to treat seriously ill and injured patients who require urgent attention. While not all Emergency Departments are organized in the same way, all EDs have unique characteristics. For example, the majority of visits to EDs are unexpected and unscheduled and involve immediate assessment. Most Emergency Departments are open 24 hours a day, and deal with patients of all ages and with all conditions, although there are some departments that see only children, or only adults, or only patients with eye-problems.

4.1.1 Areas and functions of ED

A typical Emergency Department has several different areas and functions for their services; each specializes in patients with particular severities or types of illness. The essential areas and functions of a modern ED are summarised below.

A patient arriving at the ED must first be registered into the hospital's information system at reception within a few minutes of arriving. After completing the registration, the patient is initially assessed by a triage nurse who makes an initial judgment of how rapidly emergency-care needs to be rendered. This process is done at the triage area and the process is sometimes called "triage," or sometimes called "initial assessment."

The resuscitation area is a key area of an Emergency Department. It requires adequate facilities but, more importantly, it requires direct supervision by experienced staff. It usually contains several individual resuscitation bays, usually with one specially equipped for paediatric resuscitation. Each bay is equipped with a defibrillator, airway equipment, oxygen, intravenous lines and fluids, and emergency drugs. Resuscitation areas also have ECG machines, and often limited X-ray facilities to perform chest and pelvis films.

The "majors" (major injuries) or general medical area is for stable patients who still need to be confined to bed. This area is often very busy, filled with many patients with a wide range of medical and surgical problems. Many will require further investigation and possible admission. The department needs enough space to cope with peaks in demand and enough staff to ensure patient-safety. The key to the proper function of this part of the department is the timely support of inpatient-teams in assessing patients referred for inpatient care and the ability of the hospital to move those patients needing admission.

Patients who are not in need of immediate treatment are sent to the "minors" (minor injuries) area. Such patients may still have been found to have significant problems, including fractures, dislocations, and lacerations requiring suturing. This is the highest patient volume area of the department. The staffing will depend on local circumstances;

EM doctors, GPs, Emergency Nurse Practitioners or Advanced Physiotherapy Practitioners work as part of a team in this service.

A paediatric area for the treatment of children has recently become standard, to dedicate separate waiting-areas and facilities for children. Approximately 40% of general EDs in England have separate facilities for children that are staffed 24 hours-a-day (Commission for Healthcare Audit and Inspection, 2005). 25% of patients attending a general ED in the UK are children (BAEM, 2007).

There is another essential part of the ED called the Clinical Decision Unit. It allows time for the assessment and investigation of those patients with more complex conditions. Such units allow the safe discharge of patients and outpatient-management of conditions that would in the past have required admission to hospital.

Some modern ED may also have a separately-streamed service for minor and rapidly treatable conditions, such as minor injuries. The fast track may be staffed by Emergency Nurse Practitioners, Physician-assistants and/or Physicians, and special consultation rooms are specifically designated for this purpose. This system allows for quicker treatment of patients who may otherwise be forced to wait for more pressing cases to be resolved. This part of the department may be called by several names e.g. Urgent Care Centre, Fast Track Unit, 'See and Treat' or Primary Care Suite depending on the countries or local emphasis.

4.1.2 Resources in EDs

The resources in Emergency Departments are of mainly two types; human resources and other physical resources like any other service. Emergency Departments must possess the staff and other resources necessary for the care of all individuals presenting to the department. Resources should exist in the department to accommodate each patient

from the time of arrival through all processes: assessment, evaluation, treatment, and disposition.

Human Resources:

Human resources are the most important factor in providing an appropriate, timely and clinically-effective service to patients in the ED. Staff in the ED are of mainly three types i.e. medical staff, nursing staff, and ancillary and other staff. Because of the unscheduled and episodic nature of health emergencies and acute illnesses, experienced and qualified medical, nursing, and ancillary personnel must be available 24 hours a day to provide the necessary care in the ED. The emergency medical staff, emergency nursing staff, and other additional medical team members are the core components of the emergency medical-care system and all the staff under each group are given in Table 4.1.

Medical staffing	Nursing staff	Ancillary and other staff
Consultants	Nurse Managers	Managers
Associate Specialists	Nurse Consultants	Receptionists
Staff Grades	Modern Matrons	Secretaries
Specialist registrars	Nurse Practitioners	Security
Other middle grades	NHS nurses (all grades)	Porters
SHOs	Nursing Students	Radiographers
PRHOs	Agency Nurses	Physiotherapists
Medical Students.	Healthcare Assistants.	Occupational Therapists
		Play Therapists
		Plaster-technicians

Table 4.1 Staff in a typical Emergency Department

Physical Resources:

The ED is designed to provide a safe environment in which to render care; and to enable convenient access for all individuals who arrive for care. It also should be designed to protect, to the maximum extent reasonably possible consistent with medical necessity, the right of the patient to visual and auditory privacy. Physical resources used in EDs are of mainly three types; facilities, equipment and supplies, and pharmacological/therapeutic drugs. The facility for ancillary services such as radiological, imaging, and other diagnostic services and laboratory services must be available within a reasonable period of time for individuals who require these services. Equipment and supplies and necessary drugs must be of high quality and should be appropriate to the reasonable needs of all patients anticipated by the ED and immediately available in the facility at all times. The specific ancillary services and laboratory capabilities available and the timeliness of availability of these services for emergency patients in an individual hospital's ED should be determined by the medical director of the ED in collaboration with the directors of the services and other appropriate individuals. A full list of equipment and supplies, pharmacological /therapeutic drugs, radiological, imaging, and other diagnostic services and laboratory capabilities in ED is given in Appendix 1.

4.1.3 ED Processes

The ED process has mainly four important components: Source of Arrival, Registration and Triage, Assessment and Treatment, and Disposition. These components are briefly described in following.

Source of Patients' Arrival:

The patients arrive at the Emergency Department from different sources. Those sources are;

- self-referral
- emergency-ambulance
- referral by General Practitioner (GP)
- referral by other healthcare professionals (e.g. NHS Direct, Walk-in Centre)
- referral by other service providers (e.g. police, school).

What-ever the arrival source, all the patients need to be registered and attended to the triage-process except the very urgent cases arriving by ambulance.

Registration and Triage:

The registration is the very first and a simple process in ED, and it takes only a few minutes to register the patient on the hospital information system. After the registration, the patient is immediately attended to by the triage process. The triage process is a critical step in patient-throughput from the standpoint of both the quality of care and resource utilization. The idea of triage is to find out who can best deal with the patient and in which area of the department the patient can be dealt with, whether any treatment or investigations can be started, and whether the patient needs to be seen urgently. This process also allows the patient to be given pain-killers as soon as possible. Patients with life or limb-threatening conditions may bypass triage and be seen directly by a physician. Sometimes the patient can be treated on the spot, or directed to a more appropriate service. Patients are seen in order of medical urgency, not in order of arrival. Most Emergency Departments allocate each patient a “triage category,” which indicates in which order patients should be seen, not necessarily how serious the problem is. At some time or other, most EDs have used a 5-colour triage system: Blue, Green, Yellow, Orange and Red. In this system, Blue denotes the least severe cases and

Red are real emergencies in which life is at risk (Manchester Triage Group et al, 2006).

Assessment and Treatment:

Once a patient has been effectively registered and triaged, the patient is moved to the next process and evaluated by an ED physician or nurse practitioner, who often orders a series of patient- and problem-specific diagnostic tests such as x-rays, electrocardiogram, and blood tests. In this process the patient may be moved into other areas in order to have certain tests done, particularly radiological and other imaging tests. The physician also decides that the patient needs to be seen by a specialist or that the evaluation should continue. Sometimes patients can be treated and discharged, and some will need to be admitted to hospital depending on the patient-acuity. Many Emergency Departments have their own wards to which patients can be admitted for short periods of observation or treatment. Depending on information obtained by continuous monitoring, a previously-chosen course of diagnostic testing or therapeutic intervention may need to be modified. Finally the decision is made as to whether the patient needs to be admitted to the hospital, or can be safely discharged home or transferred to another destination.

Disposition:

Disposition refers to the discharge of patients from the ED to the next phase of care as appropriate. The disposition of the patient is dependent on his/her condition and acuity level. The main dispositions from EDs are as follows.

- Discharge home;
- Discharge to another community facility;
- Referral to outpatient care;
- Admission to the patient's own hospital (regular ward, ICU / HDU or theatres);

- Admission to another hospital;
- Mortuary.

4.2 Emergency Departments in the UK

The English National Health Service (NHS) is one of largest healthcare systems in the world. Its annual budget is more than £70 billion and it employs 1.3 million staff. There are 202 major A&E departments in England that are open 24 hours a day. They have the resources to deal with all emergency cases and have access to a complete range of medical and surgical specialties. They are attended by more than 13 million people every year and range in size from 20,000 patients per annum to over 100,000 patients. A typical department is attended 60,000 patients per year, which translates into approximately 10 patients arriving per hour at the peak times between 9am and 7pm (Commission for Healthcare Audit and Inspection, 2005).

Most EDs are facing an inexorable rise in new-patient attendances. The national average increase in the UK is usually quoted as 2% per annum, although many centres have seen rises of over 10% in recent years (BAEM, 2005). The increased demand has not been matched by greater resources and the number of medical staff has been a particular problem. The Commission for Healthcare Audit and Inspection (2005) reported that the average percentage of vacancies for nurses in England is 8% and it rises to 16% in London.

Figure 4.1 shows the patient-flow through a typical Emergency Department in England. In this flow the patients arrive at the ED by two modes: by walking in or by ambulance. In a typical Emergency Department the largest group is those who make their own way and walk in. Approximately 20% of patients are brought in by ambulance, either referred by their GP or following an emergency call (Commission for Healthcare Audit

and Inspection, 2005). In some emergency cases, patients coming in by ambulance bypass ED and go straight to an assessment unit or ward, but in other cases they will still go through ED.

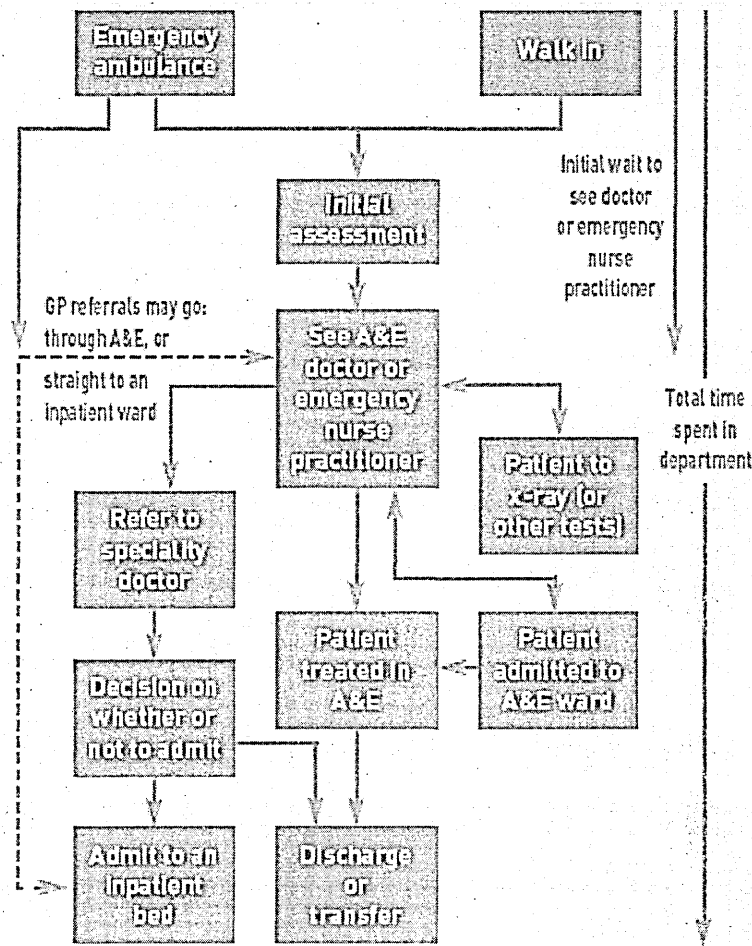

Figure 4.1 Patient-flows Through a Typical Emergency Department
(Commission for Healthcare Audit and Inspection, 2005)

The patients receive an initial assessment or triage, before being seen by a doctor or Emergency Nurse Practitioner who can diagnose their condition and treat them. The flow of the patient is dependent very much on the condition of the patient. Most patients are investigated, treated and discharged. Approximately 20% of patients are assessed as needing further treatment and admission i.e. they leave for a hospital inpatient bed or, in some cases, a medical assessment unit for further investigation. If a patient needs

further observation in ED, s/he may be admitted to a ward under the care of an ED consultant. A few, perhaps up to 5%, are transferred to another hospital, usually because they require access to more specialist facilities (Commission for Healthcare Audit and Inspection, 2005). The patient needs to wait before each process in ED until his turn. Figure 4.1 shows two principal time-intervals that have most impact on patients: they are the initial wait to see a doctor or Emergency Nurse Practitioner, and the total time spent in the department before admission, transfer or discharge.

In England, the government has specified that 98% of patients should be seen, treated and either admitted or discharged within 4 hours of arriving in the Emergency Department. The Department of Health in England has analysed breaches of the four hour waiting-time with three groups of patients and the summary is given in Table 4.2. While the great majority of patients with minor injuries or illnesses were dealt with in less than four hours, 23% of patients who had more serious conditions or required admission stayed in the ED for longer than four hours. These data reveal that the government target on waiting-times and delays is still not being achieved and further studies are needed to improve the delays in the Emergency Department.

Type of Patient	Proportion of Total Attendees (%)	Waiting More Than Four Hours (%)
Minor	57	2
Major not admitted	23	7.5
Admitted to hospital	20	23

Table 4.2 Patient-attendance and Waiting More Than Four Hours in England (Department of Health, 2004)

4.3 The ED in Sheffield Children's Hospital

As a case study the researcher studied the patients flow in the Emergency Department of Sheffield Children's Hospital to get the further knowledge about the ED process and patients' flows. Sheffield Children's Hospital is one of only eight specialist children's hospitals in the UK and represents a unique combination of facilities, expertise and understanding. The hospital provides specialist care for the children up to 16 years old within the primary catchment area being the North Trent region, but it also has some patients referred from all over the country. More than 40,000 patients attend at the Accident and Emergency Department and nearly 9,000 children are admitted into hospital as emergency every year

The researcher analysed nearly 43000 patients' attendance-data at this Emergency Department in the year 2005 using the Minitab statistical package. The annual attendance of patients at Sheffield Children's Hospital's Emergency Department also continually increases showing the UK national trend as well as the trend in many other developed countries. The figure 4.2 shows the annual trend of attendance from 1999 to 2005.

Patients arriving at this Emergency Department also mainly use two arrival-modes i.e. their own transport or the ambulance service. 92 % of patients of this ED use their own transport, and nearly 8% of patients use an ambulance to arrive at the Emergency Department. The other important finding of this arrival-data analysis is that more than 98% of patients are self-referred patients while only 2% of patients are referred by GPs or all other healthcare services.

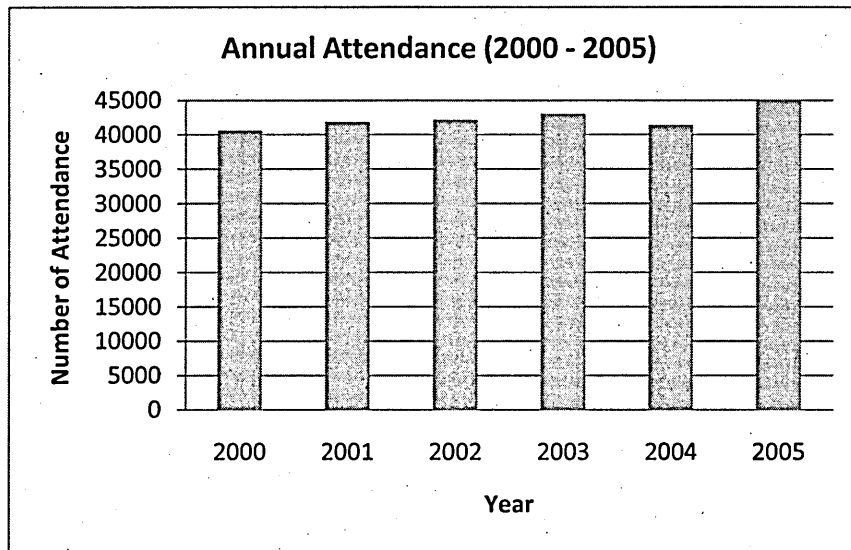

Figure 4.2 Annual Attendance at Sheffield Children's Hospital (2000- 2005)

Since the number of patient-arrivals is beyond the control of the Emergency Department, the ED manager needs to adjust the system and operations according to the arrival of patients. Therefore, analysis of the patient-arrivals is a very important part of the ED management. The ED arrivals are varied according to time: mainly the season, the day of the week and the hour of the day etc. The arrival of patients at the Emergency Department of Sheffield Children's Hospital is carefully analysed in this section. Figure 4.3 shows the hourly arrivals-patterns of this ED by the day of the week in the year 2005.

Even though Figure 4.3 shows a similar pattern of the hourly arrivals of patients between the days of the week, the researcher further conducted the Paired T-test using the Minitab software-package to test the hypothesis "there are no differences of hourly arrivals-patterns between the days of the week". The results of this analysis and Minitab outputs are given in Appendix 2. According to this analysis there is no significant difference of hourly arrival patterns between Sundays and Mondays, Tuesdays and Wednesdays, and Thursdays and Fridays. In other words, there is a similar pattern of

arrivals in between these pairs of days. It also reveals that there are significant differences of the arrivals between the other days of the week. It means there is no similar pattern of arrivals between the other days of the week.

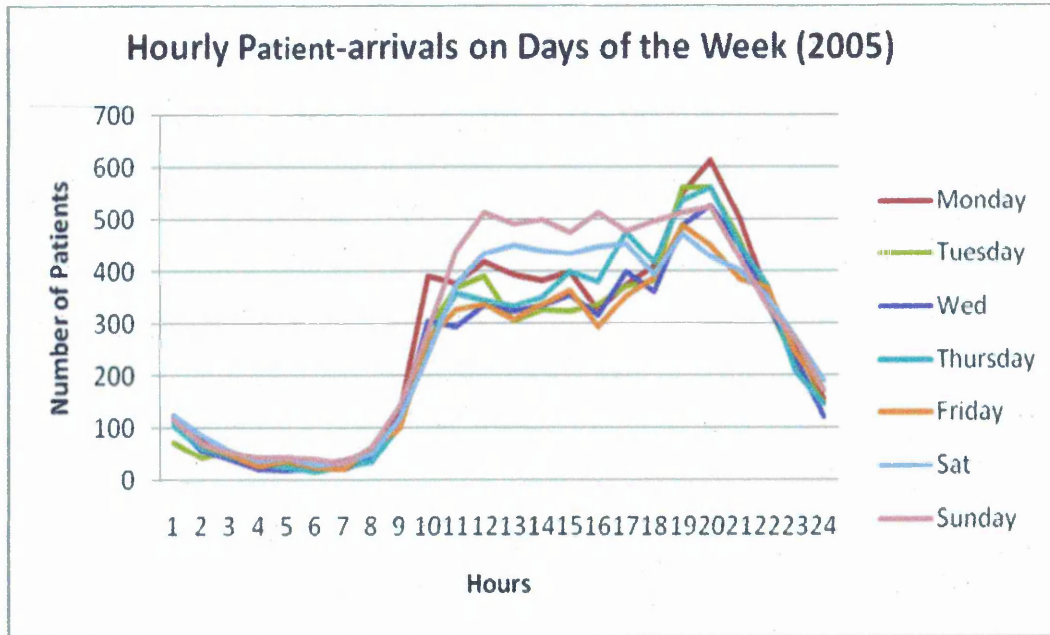

Figure 4.3 Hourly Patient-arrivals on the Days of the Week in 2005

The researcher also conducted a Paired T-test to compare the significant differences of the daily patient-arrivals between the months of the year to check the seasonal variation of the arrivals. The Minitab output and the test-results of this analysis are given in Appendix 3. The test-results reveal that there are significant differences of arrivals-patterns between the months February and March, April and May, May and June, July and August, and August and September. The analysis also reveals that there are similarities of the arrivals of patients between the months January and February, March and April, June and July, September and October, October and November, November and December, and December and January.

Another important uncontrollable factor in the Emergency Department is the acuity-level of the patients. Sheffield Children's Hospital also uses the 5-colour triage system: Blue, Green, Yellow, Orange and Red like most Emergency Departments in the U.K. These colours are assigned according to the acuity-level of the patients. In this, Blue is the least severe cases and Red is real emergencies in which life is at risk. Since the patient-flow through the ED is dependent on the acuity-level or triage-code of the patients, it is necessary to analyse the arrivals according to the triage-code of the patients. Annual patient-arrivals at the ED in Sheffield Children's Hospital are given in Table 4.3. It shows nearly 93% of arrivals are DD (Green) category patients without immediate danger or distress.

Triage Code	No of patients	Percentage (%)
Red (AA)	48	0.1
Orange (BB)	151	0.4
Yellow (CC)	2522	6.2
Green (DD)	37523	92.9
Blue (EE)	150	0.4

Table 4.3 Patient-arrivals by Triage-category (2005)

All the patients arriving at the Emergency Department must register on the hospital information-system and then are attended to via the triage-process except for some urgent patients who come by ambulance and may bypass registration and triage (registration and triage are done for these patients en-route to the Emergency Department). The patients mainly go through six processes; registration, triage, examination by physician, lab test/x-ray, examination by specialist and treatment depending on the individual patient's triage-category. The patient-process flow through this Emergency Department was mapped using a flow-diagram and shown in figure 4.4.

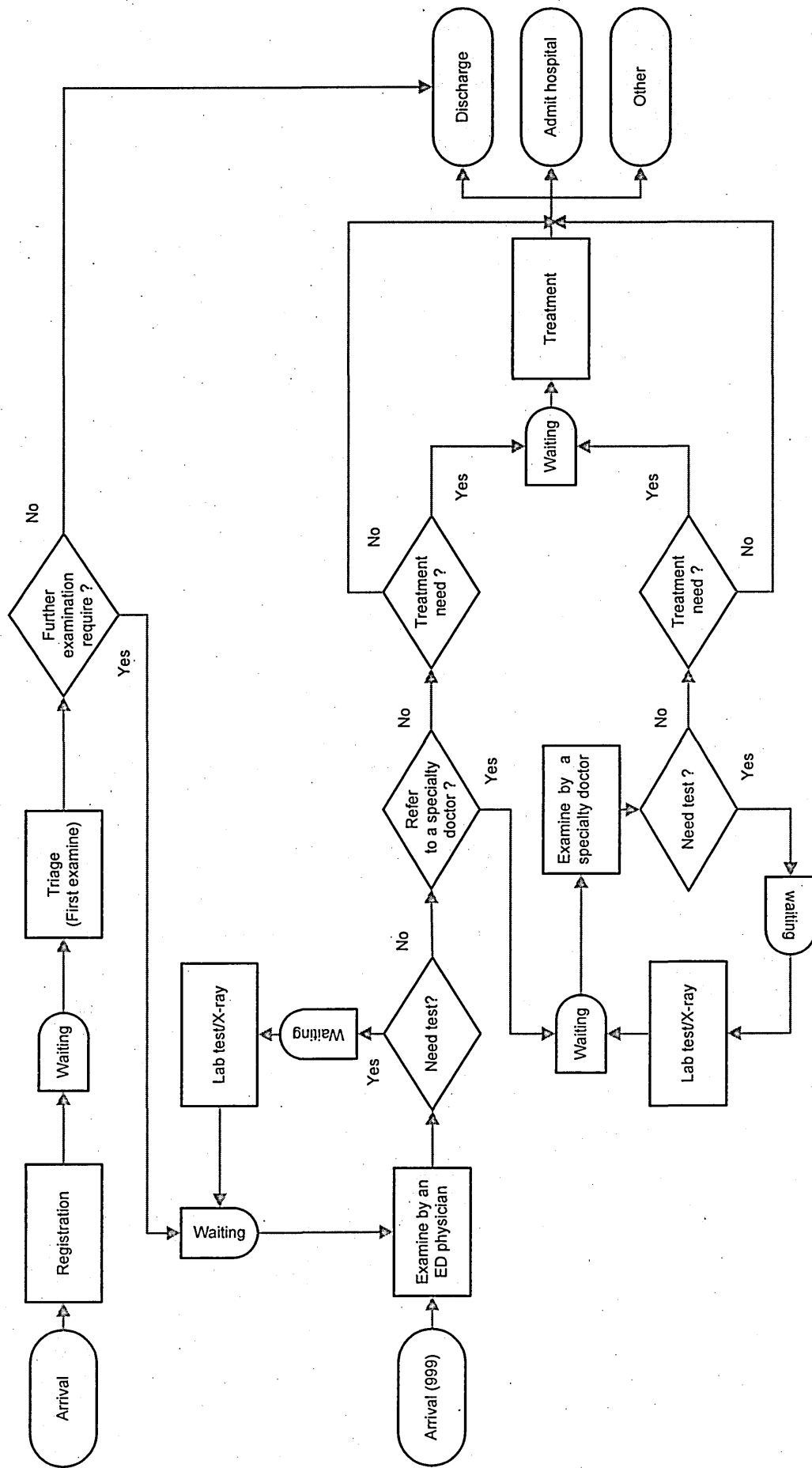

Figure 4.4 Patients Process Flow in the Emergency Department 75

4.4 Summary

This chapter attempted to give an overview of the Emergency Department and its operation in hospitals. It described the comprehensive nature of the emergency-care and Emergency Department operations including the ED function, resources and processes. It also discussed the current practices in Emergency Departments in England including patient-flows and waiting-time practices. Finally it studied the patients flow in the Emergency Department of Sheffield Children's Hospital to get the further knowledge about the ED process and patients' flows. The next chapter of this thesis will analyse the overcrowding problem in Emergency Departments.

CHAPTER FIVE

5. The Overcrowding Problem in Emergency

Departments

As explained in Chapter 2.8, overcrowding with its concomitant delays is the most important, growing, complex problem to solve in Emergency Departments. A large number of studies have been published concerning the international problem of overcrowding, waits and delays in EDs. It is very important to analyse this overcrowding problem before the development of the decisions-framework to overcome the problem. This chapter discusses and analyse the overcrowding problem within the context of this research, including the definitions, causes, and consequences of the overcrowding as well as the current solutions which have been taken to overcome the problem.

5.1 Definitions of Overcrowding

The concept of overcrowding in ED is described using many terms including “overcrowding”, “crowding”, “congestion”, “delay”, and “waiting” with the same meaning in different studies. There is not a universally-held standard definition for the overcrowding problem in Emergency Departments. Therefore the measures of overcrowding and waits vary in different countries making it difficult to compare this problem. Various studies have developed definitions of overcrowding, but in its simplest form, it exists when there is an excess demand for an Emergency Department. This mismatch between the demand and supply of ED service affects the ability of Emergency Departments to deliver effective care, and the whole hospital care-system.

The American College of Emergency Physicians describes ED overcrowding as “*A situation in which the identified need for emergency services outstrips available resources in that ED. This situation occurs in hospital EDs, when there are more patients than staff and ED treatment beds; and when wait-times exceed a reasonable period. Overcrowding typically involves patients being monitored in non-treatment areas and awaiting ED treatment beds or inpatient beds. Overcrowding may also involve an inability to appropriately triage patients, with large numbers of patients of any triage assessment category in the ED waiting-area.*” (Overcrowding Resources, 2002).

The Canadian Association of Emergency Physicians and the National Emergency Nurses Affiliation, (2003) defines EDC as a “*situation in which the demand for emergency services exceeds the ability of a department to provide quality care within acceptable time-frames*”.

Internationally a variety of definitions are used for overcrowding, and in England the issue is referred to as excessive wait rather than overcrowding. The NHS Plan (Department of Health, 2000) has defined an excessive wait as more than four hours total time in the Emergency Department (measured from the time a patient arrives until they leave the Emergency Department).

Some have described overcrowding on the basis of excessive waiting-times to see an ED physician or based on treatment-time delays in the ED. Others have based the definition on delays in the movement of admitted ED patients to inpatient beds. For some, the definition is based on the number of patients versus the number of available ED treatment beds, or the forced use of the ED hallway to care for or hold ED patients. Others have attempted to define overcrowding on the basis of an assessment of patient

acuity in the ED in relation to staffing resources. Some link ED overcrowding to the need to divert incoming ambulance transports (Gordon et al., 2001).

In addition to above there are a number of commonly-held definitions for overcrowding including patients placed in hallways; all ED beds occupied for more than 6 hours per day; a full ED waiting-room for 6 hours or more per day; physicians feeling rushed for 6 hours or more per day; and the number of acutely-ill patients who wait more than 60 minutes to see a physician (Derlet, 2001, Richards, 2001). In the literature, there are no easy definitions or formulas to determine when an ED is overcrowded to an unsafe level. From the above definitions, overcrowding can be interpreted as a phenomenon that involves the interaction of the demand and supply in the Emergency Department.

5.2 The Consequences of Overcrowding

ED overcrowding could potentially affect anyone who suffers unexpected severe illness or injury requiring time-sensitive emergency treatment. A wealth of research demonstrates the severe consequences of Emergency Department overcrowding on patients and staff. The findings are the following:

- **An Increased Number of Medical Errors**

Patient safety is at risk in overcrowded EDs because of the delays in provision of care, intensity of decision-making, pressure to move patients quickly through the system, and providing care in less than desirable places such as hallways and waiting areas (Canadian Association of Emergency Physicians Working Group, 2002). One report linked ED overcrowding to delays in identification and treatment of time-sensitive conditions such as acute myocardial infarction, acute stroke, acute surgical emergencies,

and severe sepsis. At least one of these cases of delayed treatment resulted in an unexpected death (Derlet and Richards, 2002).

A number of articles have documented the increase in medical errors associated with boarding and overcrowding (Weissman et al, 2007). Many of these are errors of omission and not commission since the emergency staff must simultaneously care for inpatients and focus on the new emergencies coming in the door (Cowan and Trzeciak, Clinical Review, 2005). According to the Joint Commission, 50% of sentinel events causing serious injury or death occur in the Emergency Department and approximately one third of these are related to overcrowding (Joint Commission, 2002).

Derlet et al. (2002) conducted a national random survey of 575 ED directors in 1998–1999 regarding the definition and extent of ED overcrowding and factors associated with it; and they reported one third of the directors said that patients had experienced poor outcomes as a result of overcrowding. Wilper et al. (2008) and Burt & McCaig (2006) also argue that, as a symptom of this overcrowding, wait-times are increased, and the quality and speed of care are diminished. A study of patients with acute appendicitis showed that those who had an emergency physician delay or a delay in the surgeon performing the operation had a worse outcome (Chung et al., 2000).

- **Prolonged Pain and Suffering**

This is a critical problem, because many illnesses are time-dependent and early intervention gives rise to better outcomes. The Centres for Disease Control and Prevention (CDC) in the USA found that more than 10% of patients judged by the triage nurse to be critical waited more than 1 hour to see a physician in the Emergency Department (QuickStats, 2006). Late diagnoses might be too late, with permanent consequences of disability or death (Pines, 2006). During times of overcrowding,

patients may experience prolonged pain and suffering unnecessarily because the Emergency Department staff are too busy to attend to them (Derlet and Richards, 2000).

- **A Higher Rate of Patient-deaths**

Several recent studies have compared mortality rates in patients seeking emergency care during times of overcrowding versus times of no overcrowding and concluded that the rate of death is higher during times of overcrowding (Lie et al., 2005; Sprivulis et al., 2005; Richardson, 2006). According to JCAHO (2003) a review of sentinel events has attributed patient-deaths to delays in patient-care. Delay in treatment is the most common type of sentinel event (46.2%) listed for hospital Emergency Departments. In a sentinel event alert, JCAHO (2002) reported 52 patient-deaths and EDC was cited in 31% of the cases. A quantitative study (Miro et al., 1999) also described an increase in patient-mortality with EDC in Spain.

- **An Adverse Effect on Patient-satisfaction**

Patient-satisfaction is an indicator of timely and quality care. Patients have expressed dissatisfaction with delays in treatment and delays in admission (Sun, Adams & Burstin, 2001; Sun et al., 2000; Taylor, Wolfe & Cameron, 2002). Trout et al. (2000) performed a literature review to identify factors associated with overall patient-satisfaction following attendance at Emergency Departments. They found 16 studies relating satisfaction to service and patient factors. Perceived waiting-time was consistently associated with overall satisfaction but little is known of the relationship between actual waits and satisfaction. Taylor and Bengner, (2004) also reported that waiting-times in Emergency Departments have been a key determinant of patient-satisfaction. However, Sun et al. (2000) found that perception of wait-time led to more dissatisfaction than the actual length of stay or time waiting to be seen by a physician.

- **An Increase in Numbers of Patients Leaving Before Treatment**

The dissatisfaction of patients is reflected in an increasing number of patients who leave without being seen. In some cases, patients decide not to endure the long wait and simply leave without having received evaluation or treatment. According to Pexton (2003) an average of 1.5% of all Emergency Department patients in the USA left before being seen by a physician in 2001, while this number may be 8 to 10% (or higher) in high-volume Emergency Departments.

Weiss, Ernst and Nick, (2005) found the longer patients wait, the greater the likelihood they will leave prior to receiving care. Kyriacou et al., (1999) also have shown that waiting-time is related to the proportion of patients who leave prior to receiving care. The consequence of this is the potential for minor medical problems to become more serious from delay in care. According to Richardson and Bryant, (2004) a number of these walkouts before treatment subsequently require admission to hospital.

- **Violence**

ED overcrowding and delays have also been associated with adverse outcomes (Derlet and Richards, 2000). A systematic review of violence in Emergency Departments demonstrated the association between increased violence against staff and longer waiting-times (Stirling et al, 2001).

- **An Adverse Effect on Staff**

Overcrowding adversely affects healthcare professionals. The many causes of overcrowding have had a negative effect on medical staff productivity and satisfaction. Emergency physicians have attempted to fill in the gaps, as they must stretch their

ability to see many patients at the same time. At a certain limit of patients, productivity declines and patient-care is compromised (Derlet and Richards, 2000).

- **Ambulance Diversion**

This is a dramatic consequence of overcrowding. Although an ambulance with a patient is indeed near a particular hospital, it may have to be diverted to a hospital far away, because the initial ED was full. This is called 'Ambulance Diversion' from the overcrowded hospital. This leads to higher mortality-rates for those diverted patients (Brewer 2002; Richardson, 2006). According to the CDC in USA, approximately 50% of Emergency Departments experience overcrowding, and one third of hospitals have experienced Ambulance Diversion (Burt and McCaig, 2003). When one hospital is 'on diversion', others have to take the overflow patients. Before long, the other hospitals might need to go 'on diversion' as well. This situation is referred to as "diversion override," and this occurs when all EDs in an area have called for diversion but are forced to re-open, even though they are operating at, or exceeding, capacity. Overcrowding and Ambulance Diversion have raised alarm regarding the ability of the healthcare system to respond to catastrophe (Minority Staff Special Investigations Division, 2001).

- **Increase Costs**

The overcrowding of EDs with inpatients results in an increased average inpatient length-of-stay, which leads to increased costs per patient. Bayley et al. (2002) estimated the cost in America as \$190 per patient waiting more than three hours. Overcrowding increases medical negligence claims, which increases healthcare costs for everyone. Increased average inpatient length-of-stay caused by overcrowding of the Emergency

Department has been shown to result in increased costs per patient (Krochmal and Riley, 1994).

Consequences of Overcrowding	References
An increase in medical errors.	Derlet and Richards, 2002; CEPWG, 2002; Weissman et al., 2007; Cowan, Trzeciak, and Clinical Review, 2005; Joint Commission, 2002; Derlet et al., 2002; Chung et al., 2000; Wilper et al., 2008; Burt and McCaig, 2006.
Prolonged pain and suffering.	Pines, 2006; QuickStats, 2006; Derlet and Richards, 2000.
Increased number of patient-deaths.	Lie et al., 2005 ; Sprivulis et al., 2005 ; Richardson, 2006 ; JCAHO, 2003 ; JCAHO, 2002.
Negative effects on patient-satisfaction.	Sun, Adams & Burstin, 2001; Sun et al., 2000; Taylor, Wolfe, & Cameron, 2002; Trout et al., 2000; Taylor and Bengner, 2004; Sun et al., 2000.
An increase in patients leaving before treatment.	Asplin et al., 2002; and Brown, 2002; Richardson and Bryant, 2004; Pexton 2003; Miro et al., 1999.
Violence.	Brown, 2002; Dunn, 2003; Schull et al., 2003; Derlet and Richards, 2000; Stirling et al., 2001.
Effects on Staff.	Derlet and Richards, 2000
Ambulance Diversion	Schull et al., 2003; Brewer 2002; Richardson, 2006; Burt and McCaig 2003; Burt, McCaig and, Valverde, 2002; Minority Staff Special Investigations Division, 2001; Brown, 2002.
Increased Costs	Krochmal and Riley, 1994; Bayley et al., 2002.

Table 5.1 The Consequences of Crowding in ED and References

5.3 The Causes of Crowding

The causes for emergency department crowding are numerous and interrelated. However it is a symptom of the overall crisis in a healthcare system. The crowding in emergency department is an emergency care system problem not just an ED problem (Emergency Medicine Practice Subcommittee on Crowding, 2004). Many studies have considered the causes of crowding and wait using a wide variety of techniques. The different studies indicate that causes of crowding vary between hospitals and may be multi factorial. The most of the literature in the area of crowding and waits in the emergency departments is mainly anecdotal and tends to focus on assessing the extent of the situation or giving 'expert' opinion on causes and possible solutions.

American Academy of Pediatrics (2004) has listed the 18 causes of overcrowding in emergency department. These causes are:

- Increased ED patient volumes
- Increased ED patient acuity
- Increased complexity of diseases and associated evaluations
- Lack of inpatient hospital beds and related resources
- Nursing shortage
- Physician shortage
- On-call physician/consultant availability
- Insufficient physical plant space for the ED
- Ancillary service (e.g. lab, radiology) delays
- Reduced access to primary care services
- Reduced access to subspecialty care services
- Difficulty in arranging follow-up care

- Language and cultural barriers
- Medical record documentation requirements
- Medical liability issues
- Managed care issues
- Uninsured and underinsured patients
- Inadequate funding for emergency services

Gordon and Asplin (2004) also have listed the factors contribute to delays in ED throughput (from arrival to disposition) and the non exhaustive list includes the following:

- Staffing (physician, resident, nurse)
- Available treatment areas (acute care beds, fast track)
- Arrival mode (car, ambulance, police)
- Ancillary throughput (laboratory, radiology)
- Arrival rate
- Patient acuity
- Hospital inpatient census (behavioral health, intensive care unit, telemetry)
- Housekeeping availability
- Major resources (operating room, catheterization laboratory)
- Time (season, day of week, holiday).

The NHS conducted a survey on waiting time of emergency departments in the UK (British Medical Association, 2005). They distributed a postal questionnaire among all A&E departments in January 2005 and received a response from 80 percent of departments (163/205). Forty eight percent of departments (78/163) have said they did

not meet the four hour target for the period ending 31 December 2004. The main reasons for not reaching four hour waiting target are summarised in Table5.2.

Causes of delay	Major Reason	Minor Reason	No Effect	Total
Not enough in-patient beds	69 (90%)	8 (10%)	-	77
Delayed discharges	60 (80%)	15 (20%)	-	75
Delay in accessing specialist opinion	41 (57%)	29 (40%)	2 (3%)	72
Not enough middle grade doctors	31 (46%)	28 (42%)	8 (10%)	67
Not enough nurses	31 (49%)	26 (41%)	6 (10%)	63
Department too small	22 (36%)	19 (31%)	21 (34%)	62
Delay in accessing diagnostic services	21 (30%)	41 (59%)	7 (10%)	69
Not enough SHOs	13 (22%)	30 (50%)	17 (28%)	60
Not enough consultants	16 (24%)	38 (56%)	14 (21%)	68

Table 5.2 Reasons for not reaching the four hour waiting target in the UK
(British Medical Association, 2005)

In addition to above studies, many more studies have discussed the causes of crowding in ED in literature of healthcare (Bradley, 2005). Although the relative importance of factors may vary in different countries and communities, the researcher indentified five main sources of ED overcrowding with the opinions of the selected ED managers in England and those five sources are discussed separately as follows.

- 1) Demand for ED care
- 2) Inefficient ED process and policies
- 3) Shortage of Staff
- 4) Insufficient facility, resource and technology
- 5) Factors beyond the ED and hospital

5.3.1 Demand for ED Care

The increasing of the patients demand in ED and the reduction of the number of EDs increases the overcrowding problem. ACEP (2002) reported that the number of annual ED visits between 1992 and 1999 in the US increased by 14 percent, from 89.8 million to 103 million and during the same time, nearly 10 percent of the general acute care hospitals were closed. The same report estimated the increase in the average daily ED census, amounting to 35,000 additional patients per day for all of the EDs in the US in 1999, as compared to 1992. Nawar, Niska and Xu (2005) also showed that the annual number of ED visits in the US from 1995 through 2005 increased nearly 20% from 96.5 million to 115.3 million and the number of hospital EDs decreased nearly 10% in the same period. According to the Figure 5.1, emergency department visits between 1994 and 2004 have increased by 26%, while the number of EDs has decreased by 9% and hospitals have closed 198,000 beds in the United State (Kellerman, 2006). Ostensibly, it would explain the observed overcrowding in EDs. In addition to above, six more studies have identified the increasing demand in ED as a reason for increasing ED crowding (Derlet et al., 2001, Fatovich & Hirsch, 2003, Kyriacou et al., 1999, McManus, 2001, Reeder et al., 2002 and The Lewin Group, 2002).

According to ACEP (2002) the increasing of the complexity of medical problems in ED patients also related with crowding problem. Lambe et al. (2002) reported a 59% increase in critically ill patients attended to California EDs from 1990 to 1999. The increasing severity of illness among ED patients has been attributed to age shifts in the population and a higher prevalence of patients with severe chronic medical conditions. Lambe et al. (2002) further explained that an aging population and an increasing prevalence of high complexity medical problems have increased the severity of illness among ED patients, and this has become an important determinant of ED overcrowding.

Derlet et al. (2001), General Accounting Office (2003), Moroney (2002) and Reeder et al. (2002) also have identified that high acuity and complexity of diseases increase the ED crowding. Seasonal variation (e.g. season, holiday, day of week) is also a primary factor for increasing crowding in ED (Gordon and Asplin 2004). Some studies have found Language and cultural barriers also affected the crowding in ED (Derlet & Richards, 2000 and Moroney, 2002).

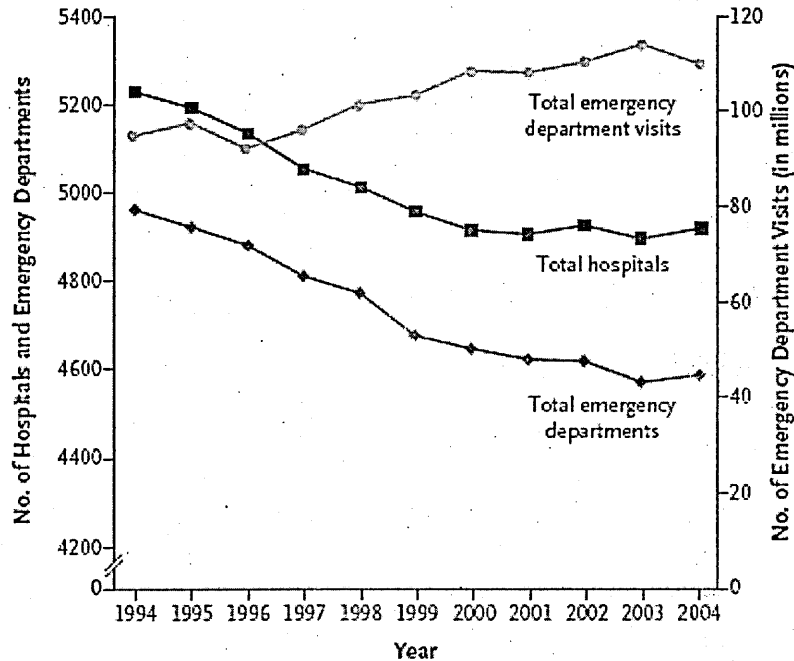

Figure 5.1 Trends in EDs in the United States, 1994–2004 (Kellermann, 2006)

5.3.2 Inefficient ED Process and Policies

A delay in the process of Emergency Departments and ancillary services affects the ability to move patients safely and efficiently through the system. Some studies have identified delay in diagnostics as one of main reasons for overcrowding in EDs (Schull et al., 2001a; Derlet et al., 2000; Andersson and Karlberg, 2001; Schumacher Group, 2002; Fletcher et al., 2004). Estey et al. (2003) reported that slow throughput of patients is one reason for overcrowding in EDs. Inpatient boarding for admission to

hospital is a common reason for overcrowding in EDs and many studies have found it as one of the major reasons for overcrowding (Asplin et al., 2002; Cameron et al., 2002; Dunn, 2003; Fatovich & Hirsch, 2003; Forster et al., 2003; Richardson, 2002; and Schull et al., 2003). A study of England Accident and Emergency Trusts found a strong correlation between ED treatment-time and hospital occupancy (Cooke et al., 2004).

Bottlenecks in laboratory, radiology, respiratory therapy and other ancillary services often contribute to ED delays and a number of studies have measured their impact on overall operational efficiency. There are many studies that have indentified delays in ancillary services as a main reason for overcrowding (Derlet, 1992; Derlet et al., 2001; Estey et al., 2003; General Accounting Office, 2003; and McManus, 2001). The availability and use of more complex technology often requires more time, attention, and patient-management than in the past. Frequently, the use of such technology, which is often shared with hospital inpatients, requires waiting time for availability that further reduces the EDs' ability to supply other services. Two studies have identified that the increasing medical record documentation requirements also affect the overcrowding problem in EDs (Schumacher Group, 2002 and Derlet & Richards, 2000).

5.3.3 Shortage of Staff

The shortage of healthcare professionals is one of most obvious factors in the current overcrowding crisis. Many researchers have identified the major contributors to the problem of overcrowding as a growing shortage of healthcare professionals. Shortage of medical staff with expanding demand have dramatically increased the workloads of the remaining workers and created an undesirable work-environment. A point-prevalence study of overcrowding in United State found that the average nurse was caring for 4 patients simultaneously, and the average physician was caring for 10 patients simultaneously (Schneider et al., 2003).

According to the American Academy of Pediatrics (2004), among all the supply-shortages in healthcare professional groups in the USA, the greatest deficiency is found within the ranks of registered nurses. It further reported that experienced ED nurses are truly the backbone of emergency care and there is a deficiency of such nurses, with vacancy-rates in some states as high as 18%. Some studies suggest that the nursing shortage is a primary contributing factor for ED overcrowding (Derlet and Richards, 2002; Richards, 2000; The American College of Emergency Physicians, 2002; Lambe et al., 2003; and Estey et al., 2003). Moorhead et al. (1999) found that real shortages in the supply of residency-trained emergency physicians and subspecialty-trained pediatric emergency physicians lead to increase overcrowding problems in the USA. A BMA survey of A&E waiting-times, (2005) also reported that one of the main reasons for not reaching four-hour waiting-targets in the UK is that there are not enough middle-grade doctors and nurses. A study in California showed that lower staffing levels of physicians and triage nurses predisposed patients to wait longer for care (Lambe, et al., 2003).

Many hospitals anecdotally reported a shortage of on-call specialists. Both the California Medical Association and the Arizona College of Emergency Physicians have issued reports identifying this as a critical problem (California Medical Association, 2001). Lambe (2003) reported that 33% of waiting-time in California EDs was related to patients waiting to see on-call physicians. When patients wait a long time to see on-call specialists, they occupy ED beds and reduce the remaining treatment-capacity.

Another notable problem that threatens the viability of the emergency-care system and leads to overcrowding is the decreasing number of medical and surgical subspecialists who are willing or available to provide consultative backup to the ED (Asplin and Knopp, 2001; Johnson, Taylor and Lev, 2001; General Accounting Office, 2003; and

McManus, 2001). AAP (2004) reported that the shortages in key medical subspecialties and surgical specialties and variations in geographic availability are both long-standing contributors to ED overcrowding, particularly for rural hospitals. Derlet (1992) identified the shortage of radiologists is also affecting the crowding in EDs. In addition to the above shortage, EDs face vacancies for several other types of care-giver as well, such as technicians, nursing assistants, and housekeeping and maintenance personnel. For example, the vacancy-rate in US in 2001 for imaging technicians was 15.3% and laboratory technicians 9.5% (The American Hospital Association et al., 2001).

5.3.4 Insufficient Facilities, Resources and Technology

A lack of facilities, resources and technology adversely impact on patient waiting-times and overcrowding in ED. The factor most commonly associated with overcrowding is the inability to transfer existing ED patients to hospital inpatient beds. The inability to transfer the patients may arise from a lack of available inpatient hospital beds. This leads to keeping patients in the ED for a longer period of time "boarding" and requires staff, space and equipment that cannot be used for other patients waiting to be seen.

Gordon (2001) and Richardson (2002) identified the most important cause of ED overcrowding as the insufficient inpatient capacity for ED patients who require hospital admission. Schull et al. (2003) reported the lack of inpatient beds is the most important contributor to overcrowding and ambulance diversion in ED. Fatovich (2002) suggests that ED overcrowding is not limited to the United States, and inpatient-capacity has been cited as the most important factor in ED overcrowding in other countries as well. The American Academy of Pediatrics, (2004) reports that ninety percent of the surveyed hospitals in the US reported "boarding" of admitted patients in their ED, with nearly 50% indicating an average boarding time of 2 hours or longer.

ED overcrowding has been linked to inadequate inpatient bed availability in the United Kingdom and Australia (Acute Health Division, 2001), and has been recognised as an “international symptom of healthcare system failure” (Graff, 1999). The General Accounting Office (2003) also identified the boarding of hospital inpatients in the ED as the most important contributing factor to ED overcrowding and ambulance diversion. Lack of available beds will not only delay those requiring a bed but create a log-jam effect, leading to unavailability of space, and consequent delay of other patients’ discharge from the Emergency Department. In addition to the above, there are many other studies which have found a lack of inpatient beds as a main cause for overcrowding (Dunn, 2003; Forster et al., 2003; General Accounting Office, 2003; Moroney, 2002; Proudlove et al., 2003; Fletcher et al., 2004; and The Lewin Group, 2002).

According to Derlet et al., (2001), insufficient ED space also has become a cause of overcrowding in ED. Estey et al., (2003) found that slow or incompatible information systems also lead to increased overcrowding in ED. The shortage of specialist services is another cause of overcrowding. Some EDs do not have site-based specialty services (e.g., orthopaedics, paediatrics and psychiatry) and ED staff needs to coordinate patient-transfers with staff to places that services are available and such transfers could increase overcrowding.

As the capabilities of medicine increase, new, more complex, and more expensive diagnostic equipment becomes a necessary part of patient-care. Some of these procedures cause increasing overcrowding either because of the shortage of equipment needed, or the time necessary for lengthy tests and procedures. Some patients may need a variety of tests, all of which can be performed only in an ED or a hospital setting.

Hence, advancing technology makes the ED an attractive alternative and is a potential cause for overcrowding.

5.3.5 Factors beyond the ED and Hospital

As mentioned in the sub chapter 5.3, the overcrowding is not only the Emergency Department problem. Some studies in emergency-care literature have reported the factors beyond the Emergency Department that lead to increased problems of overcrowding. Lack of funding for healthcare and emergency-care is one of the main reasons for the increase in the overcrowding problem (Richardson et al., 2002). Cuts in funding for healthcare and hospitals have led to diminished hospital and ED capacity. The closure of hospitals, trauma centres and community health clinics, and curtailment of charity care to the indigent, have downstream effects of an inadequately funded healthcare system leading to ED overcrowding. During the period 1994 to 2004 the number of Emergency Departments in the US has decreased by 9% while ED visits have increased by 26% (Kellerman, 2006). Fatovich & Hirsch, (2003) and the General Accounting Office, (2003) also report that closure or the decreased hours of other hospitals increase the patient-demand and overcrowding in the remaining EDs.

Lack of primary care is another main reason for overcrowding in EDs. The ability to get an urgent or timely appointment with a primary care doctor has become increasingly difficult in some countries, and patients who lack access to primary healthcare often seek care and treatment in Emergency Departments. This leads to an increase in the overcrowding problem in EDs (Burt et al., 2004; Brewster LR et al., 2001).

Lack of preventive care (Richardson et al., 2002) and community care such as home care, sub-acute care, and long-term care (Estey et al., 2003; Schull et al., 2001a) are also reported as a cause of overcrowding in EDs.

The summary of this review of causes of overcrowding in ED is presented with the references in the Table 5.3 and in the Fish-bone Diagram in Figure 5.2. The Fish-bone Diagram is useful to further understand the main categories of causes and the various factors leading to an increase in the overcrowding problem in hospital Emergency Departments. According to this analysis, the main categories of causes of overcrowding are of two types; causes within the control of Emergency Departments and causes beyond the immediate control of the Emergency Departments. The Fish-bone Diagram shows key elements that contribute to the overcrowding and indicates which may be controllable within the ED. The two un-shaded categories in the Fish-bone Diagram i.e. Demand for ED Care and Factors beyond the ED and Hospital are beyond the immediate control by ED managers. Other three shaded categories i.e. Inefficient ED process and policies, Shortage of Staff, and Insufficient facility, resource and technology are able to be managed within the Emergency Department and hospital. Under each main category, many sub-causes of overcrowding are identified and presented in the Fish-bone Diagram.

Causes of ED Overcrowding	References
<p><u>Demand for ED care</u></p> <p>Increase in ED patient-demand</p> <p>High patient-acuity and complexity of diseases</p> <p>Language and cultural barriers</p> <p>Seasonal Variation (e.g. season, holidays, day of the week)</p>	<p>Kellerman, 2006; Nawar, Niska and Xu, 2005; ACEP, 2002; Derlet et al., 2001; Fatovich & Hirsch, 2003; Kyriacou et al., 1999; McManus, 2001; Reeder et al., 2002; and The Lewin Group, 2002</p> <p>Lambe et al. 2002; Derlet et al., 2001; General Accounting Office, 2003; Moroney, 2002; and Reeder et al., 2002</p> <p>Derlet & Richards, 2000; Moroney, 2002; AAP, 2004</p> <p>Gordon and Asplin, 2004</p>
<p><u>Inefficient ED Process and Policy</u></p> <p>Delays in diagnostics</p> <p>Boarding patients for admission to hospital</p> <p>Slow throughput of patients</p> <p>Delays in ancillary services (laboratory, radiology, respiratory therapy, etc.)</p> <p>Medical record documentation requirements</p>	<p>Schull et al., 2001a; Derlet et al., 2000; Andersson and Karlberg, 2001; The Schumacher Group, 2002; Fletcher et al., 2004</p> <p>Asplin et al., 2002; Cameron et al., 2002; Dunn, 2003; Fatovich & Hirsch, 2003; Forster et al., 2003; Richardson, 2002; Schull et al., 2003</p> <p>Estey et al., 2003</p> <p>Derlet, 1992; Derlet et al., 2001; Estey et al., 2003; General Accounting Office, 2003; and McManus, 2001</p> <p>Schumacher Group, 2002; Derlet & Richards, 2000; AAP, 2004</p>
<p><u>Shortage of Staff</u></p> <p>Shortage of ED nurses</p> <p>Shortage of physicians</p>	<p>Schneider et al. 2003; AAP, 2004; Derlet and Richards, 2000; ACEP, 2002; Lambe et al., 2003; Estey et al., 2003</p> <p>Moorhead et al. 1999; Schneider et al., 2003; BMA survey of A&E waiting-times, 2005; AAP, 2004; Lambe et al., 2003</p>

<p>Unavailability of on-call physician/ specialists</p> <p>Shortages of medical and surgical subspecialists</p> <p>Shortages of other support-staff (radiologists, technicians, housekeepers, etc.)</p>	<p>California Medical Association, 2001; Lambe (2003)</p> <p>Asplin and Knopp, 2001; Johnson, Taylor and Lev 2001. AAP, 2004; BMA survey of A&E waiting-times, 2005</p> <p>General Accounting Office, 2003; McManus, 2001; Derlet, 1992; American Hospital Association et al., 2001</p>
<p><u>Insufficient facilities, resources and technology</u></p> <p>Lack of inpatient beds</p> <p>Unavailability of ancillary services</p> <p>Insufficient ED space</p> <p>Slow or incompatible information systems</p>	<p>Gordon, 2001; Richardson et al.; 2002, Schull et al., 2003; Fletcher et al., 2004; Regan, 2000; Fatovich, 2002; AAP, 2004; Curry et al., 2003; AHD, 2002; Graff, 1999; General Accounting Office, 2003; BMA survey of A&E waiting-times, 2005; Dunn, 2003; Forster et al., 2003; Moroney, 2002; Proudlove et al., 2003; and The Lewin Group, 2002</p> <p>AAP, 2004; General Accounting Office, 2003; Derlet et al., 2001; Gordon and Asplin 2004</p> <p>Derlet et al., 2001 ; AAP, 2004 ; Gordon and Asplin 2004</p> <p>Estey et al., 2003</p>
<p><u>Factors beyond the ED and Hospital</u></p> <p>Lack of funding</p> <p>Closure or decreased hours of other hospitals</p> <p>Reduced access to primary care</p> <p>Lack of community care</p> <p>Lack of preventive care</p>	<p>Richardson et al., 2002; AAP, 2004</p> <p>Fatovich and Hirsch, 2003; General Accounting Office, 2003; Kellerman, 2006.</p> <p>Burt et al. 2004 ; AAP, 2004</p> <p>Schull et al. 2001a ; Estey et al. 2003 ;</p> <p>Richardson et al. 2002</p>

Table 5.3 Summary of the Causes of ED Overcrowding and References

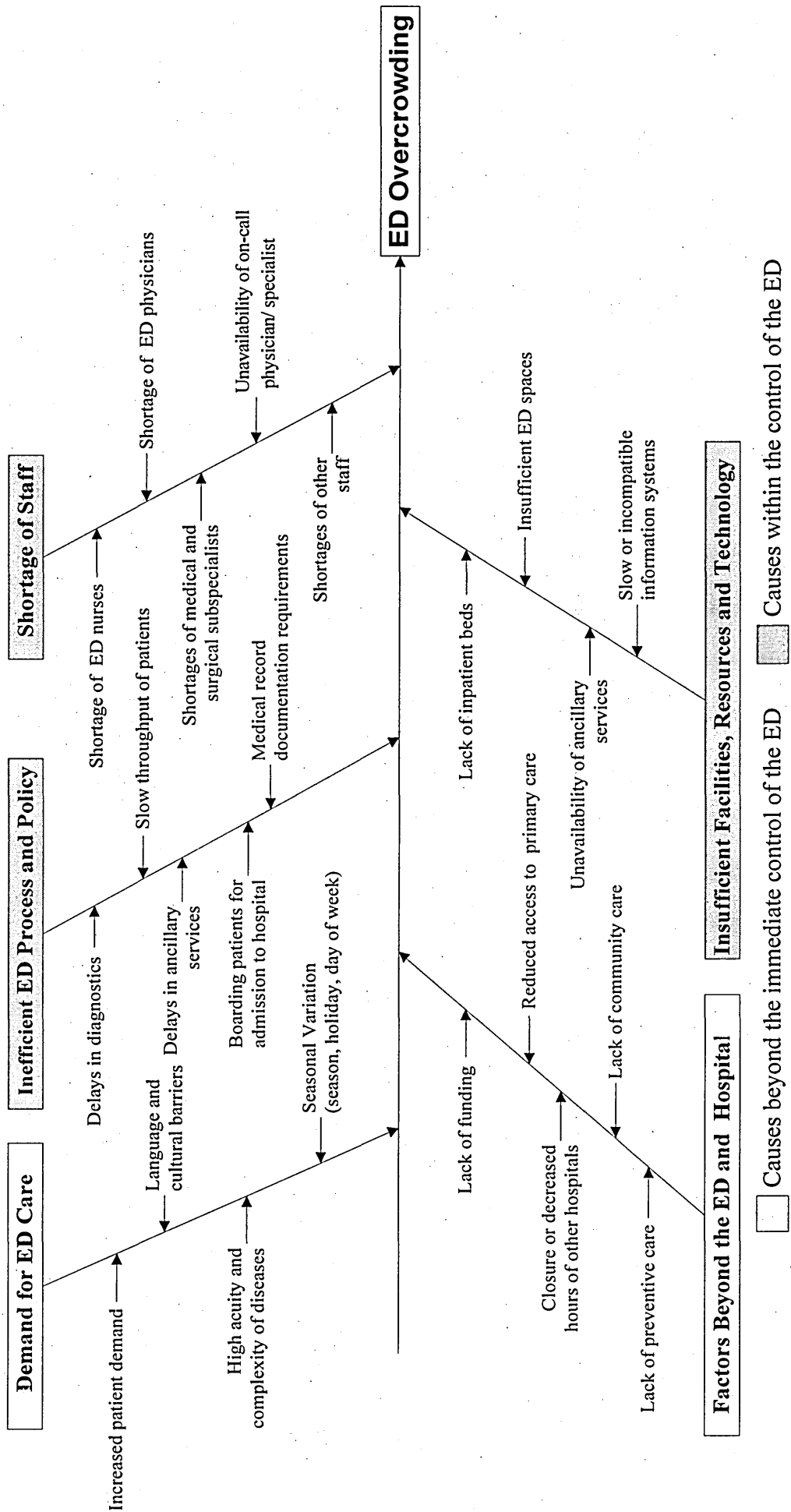

Figure 5.2 Causes of ED Overcrowding

5.4 Solutions for ED Overcrowding

Emergency Department overcrowding is a complex problem with no straight-forward easy solutions. The definitive solutions to ED overcrowding are complex, resource-intensive, and expensive. In the healthcare and emergency-care literature, there are many solutions that have been introduced to overcome this problem. But the overcrowding problem is a still-growing problem in many developed countries' Emergency Departments.

All the countries that face the overcrowding and long-delay problem in EDs have introduced some new policies, procedures and actions to overcome the problem. Bagust, Place and Posnett (1999) suggested interventions in four categories to avoid or alleviate ED overcrowding: avoid admissions; develop alternatives to admission; become more efficient at managing existing resources; and facilitate early discharges. Asplin et al. (2003) developed an input, throughput and output conceptual model of ED overcrowding as a practical framework for problem-resolution. The ACEP Task Force (2008) has identified Emergency Department actions and processes that will improve access and flow as the solutions for ED overcrowding. These actions and processes are as follows:

- Carry out a bedside registration.
- Limit triage to what is crucial and bypass triage altogether when beds are available.
- Develop a fast-track for treating simple fractures, lacerations, sore throats, etc.
- Expand the practice of observation medicine.
- Establish clearly-defined turnaround-time.
- Carefully evaluate staffing needs.

- Use scribes for documentation (to reduce documentation).
- Close the waiting room.
- Consider the use of an electronic medical record (EMR).
- Define response times for both initiation and completion of consultations.
- Implement triage protocols.
- Assign a physician to triage.
- Monitor individual practitioners in the Emergency Department.
- Defer care of non-urgent patients.
- Expand the size of the Emergency Department.
- Make use of ambulance diversion.
- Provide additional staff during times of increased volume.
- Have a clear understanding of the financial cost of the Emergency Department.

While there are many strategies reported in the healthcare literature, there is no study reporting which strategies are effective in reducing ED overcrowding. Determining the cause and effect of relationships between administrative interventions is difficult because the interventions may overlap; or they may be implemented as a bundle rather than individually; and other changes may have occurred that affected results.

As shown in sub chapter 5.3, the causes of overcrowding are mainly two types. The solutions for overcrowding can also be divided into two types, as solutions within the ED and solutions beyond the ED. This study focuses only on the solutions within the Emergency Department. Government Accountability Office, (2003) found that strategies to address ED overcrowding fell into two categories: those increasing capacity and those increasing efficiency. If the ED capacity and efficiency problems can be remedied, three main causes of ED overcrowding will have been addressed. In other

words, addressing these three causes of overcrowding will increase the capacity and efficiency of the ED. Being able to move patients quickly and efficiently through the system by improving capacity and efficiency is the key to overcoming the overcrowding problem as well as improving the patient-access, patient-safety and patient-satisfaction cost-effectively. Modelling techniques can be helpful in this regard. By developing a holistic-level decisions framework which can be used to address the overcrowding and applying the right tools and techniques, the EDs can take a more proactive approach to improving the many aspects involved in the delivery of efficient, safe and cost-effective patient-care.

5.5 Summary

Overcrowding is the most serious issue confronting Emergency Departments. It is a situation in which the demand for ED services exceeds the ability of a department to provide quality care within acceptable time frames. This chapter identified numerous effects of this problem, including increased medical errors, prolonged pain and suffering, deaths, reduced patient-satisfaction, patients leaving before treatment, violence, frustrated staff, ambulance diversion, and increasing costs. It also analysed the causes of overcrowding and identified two main causes of overcrowding i.e. causes within the control of the Emergency Department and causes beyond the immediate control of the Emergency Department. The causes within the control of the ED are the main focus of this research, and it includes Inefficient ED processes and policies, Shortage of staff, and Insufficient facilities, resources and technology. These causes are the result of inefficiencies in the management of ED capacity and patient-flow and can be improved by using the appropriate tools and techniques. The next chapter of this research develops an ED decisions-framework to address this overcrowding problem based on the findings of this chapter.

CHAPTER SIX

6. The Development of a Decisions-framework for Emergency Departments

This chapter develops a decision-framework which can be used to address the overcrowding problem in Emergency Departments. The decisions-selection for this framework is based on the causes of overcrowding found in Chapter 5 and the findings of the interviews conducted with ED managers in England. The decisions are classified into three major levels of decisions and three major areas or categories of decisions. Altogether, it includes nine managerial decisions which are highly related to the overcrowding problem in ED. The Chapter describes each decision in detail including the expected outcomes of the decisions.

6.1 The Classification of Decisions in ED

Emergency Departments make numerous clinical and non-clinical decisions in their operations. This research considers only non-clinical decisions which are associated with the overcrowding problem. The decisions considered in this research are two-dimensional. One dimension is the level of the decisions and the other dimension is the category of the decisions. The following briefly describes each dimension.

6.1.1 The Level of the Decisions

Decisions are made at three different levels in an organisation's hierarchy: strategic-level decisions (long-term), tactical-level decisions (medium-term), and operational-level decisions (short-term).

Strategic decisions or long-term decisions are the highest-level decisions. This level of decision concerns the general direction of an organisation, and its long-term goals and values. These decisions are the least-structured and most imaginative; they are the most risky and of the most uncertain outcome, partly because they reach so far into the future and partly because they are of such importance.

Tactical decisions or Medium-term decisions support strategic decisions. They tend to be medium-range, of medium-significance, with moderate consequences. These decisions share more features with operational decisions than they do with strategic decisions. They are regular and repetitive, albeit on a much longer interval than, and not necessarily totally identical with, operational decisions.

Operational decisions or short-term decisions are every-day decisions, used to support tactical decisions. The former are repetitive, with a relatively short time-scale and concerned with control rather than planning. Their impact is immediate, short-term, short-range, and usually low-cost. The consequences of a bad operational decision will be minimal, although a series of bad or sloppy operational decisions can cause harm.

Basically, these three levels of decisions in the Emergency Department are considered in this framework. The decisions selected for each level are described in the later part of this chapter.

6.1.2 The Category of Decisions

An Emergency Department makes numerous decisions from strategic-level to operational-level. In the context of this research, the selection of ED decisions for this framework is crucial. In Chapter 5, the causes of overcrowding which can be controlled within the Emergency Department are categorized into three main types i.e. inefficient ED process and policy; deficiencies in the workforce; and inadequate facilities, resources and

technology. Considering these causes of overcrowding and the suggestions of the ED managers interviewed in this framework development-process, the decisions of the ED are also categorized into three main types. These three categories are: policy and process decisions, personnel decisions, and facilities, resources and technology decisions.

6.2 The Decisions-framework for the ED

After identifying the two dimensions of the decisions i.e. the levels of the decisions and the categories of the decisions, the researcher followed a lengthy process to select the critical and relevant decisions for this framework in the context of this research. Initially, as the part of the pilot-survey identifying appropriate decisions, the researcher listed the relevant ED decisions based on the findings of the causes of overcrowding in chapter 5 and other sources in the literature survey. Then, semi-structured interviews were conducted with the managers and consultants in selected Emergency Departments in England to select the most suitable decisions under each level and categories of decisions defined in this framework and to validate the final framework. The decisions were reviewed carefully based on the findings of these interviews and the causes of overcrowding in Chapter 5. The pre-designed IDEF0¹ type diagrams are used as the schedule to interview these key informants and to record the required information under each decision. At the same time as conducting the interviews, the inputs and outcomes of the decisions as well as the control and mechanism of the decisions are also recorded using the pre-designed IDEF0 type diagrams. The completed IDEF0 diagrams are presented in figure 6.1, 6.2, 6.3 and 6.4 as follows.

¹ A brief introduction to the IDEF0 is given in appendix 6.

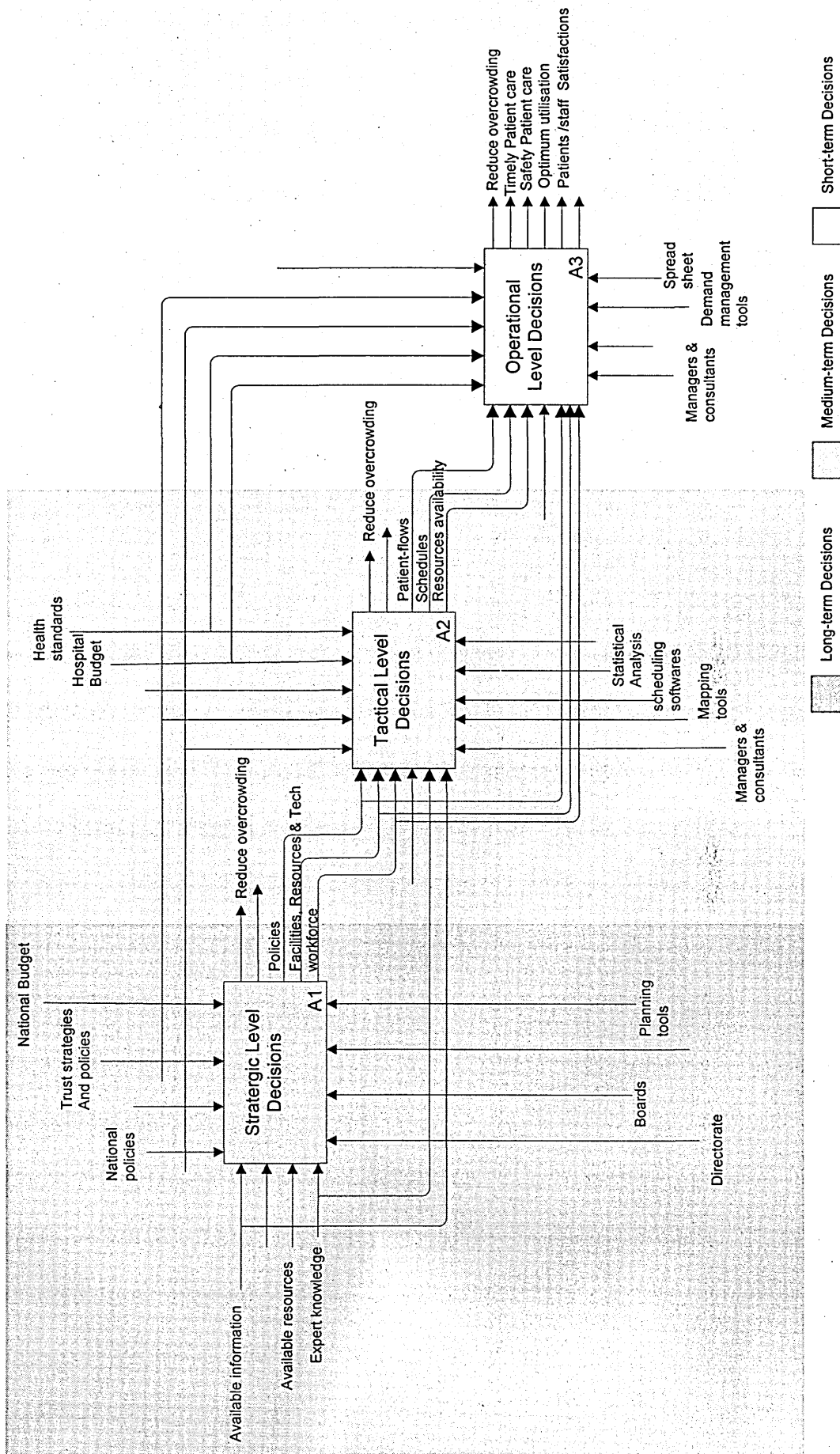

Figure 6.1 Decision-Levels in the Emergency Department

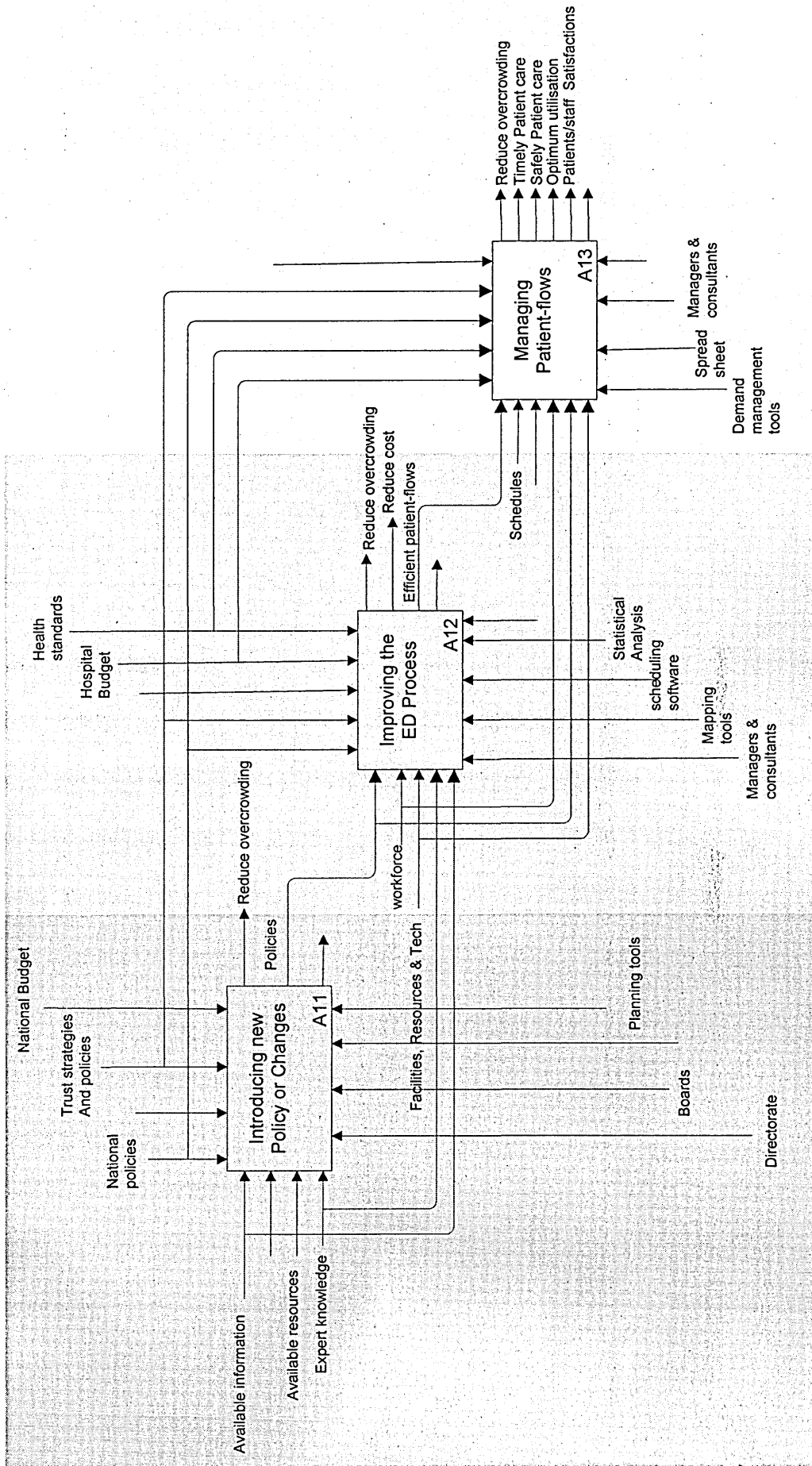
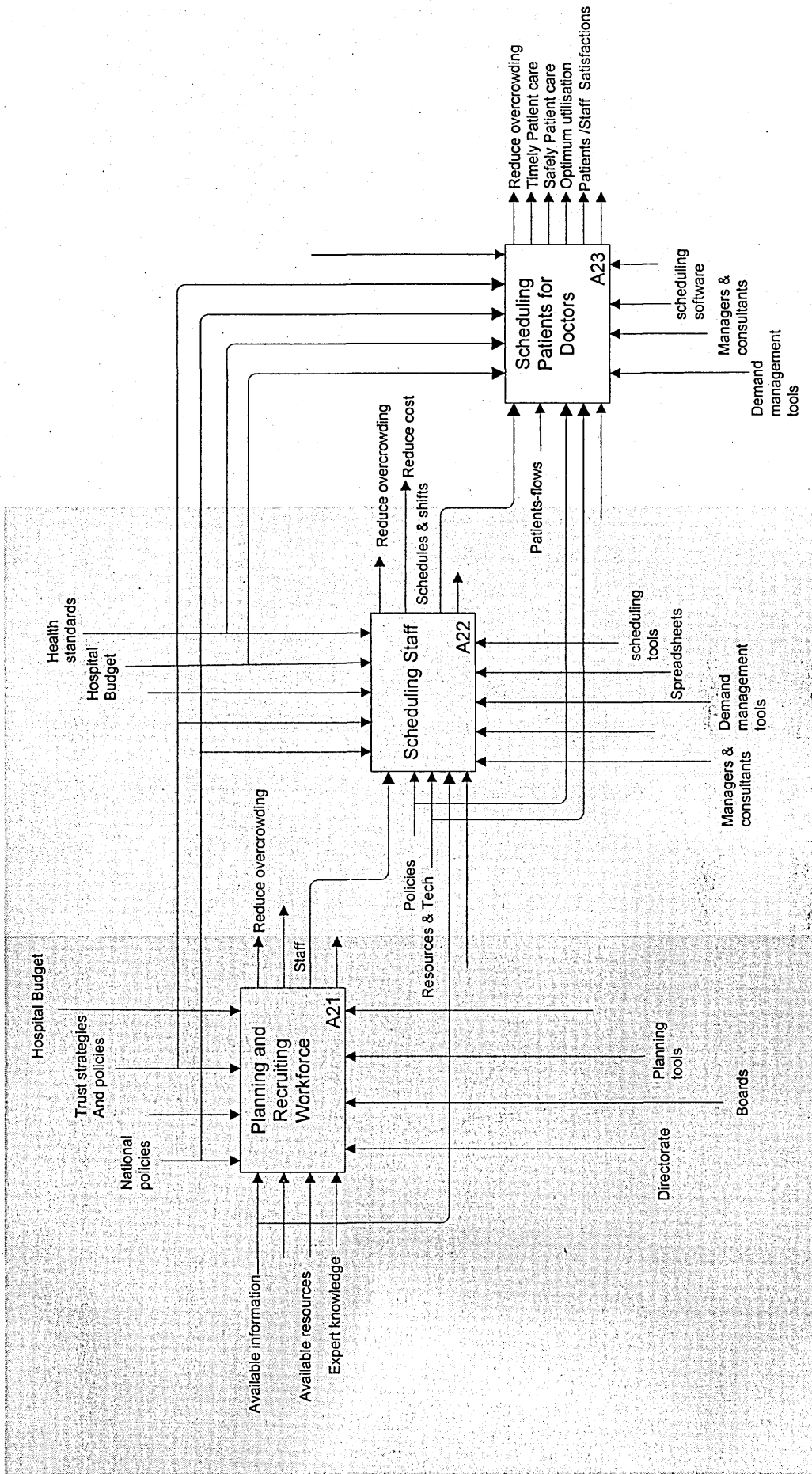

Figure 6.2 Policy and Process Decisions in the Emergency Department



Long-term Decisions
 Medium-term Decisions
 Short-term Decisions

Figure 6.3 Personnel Decisions in the Emergency Department

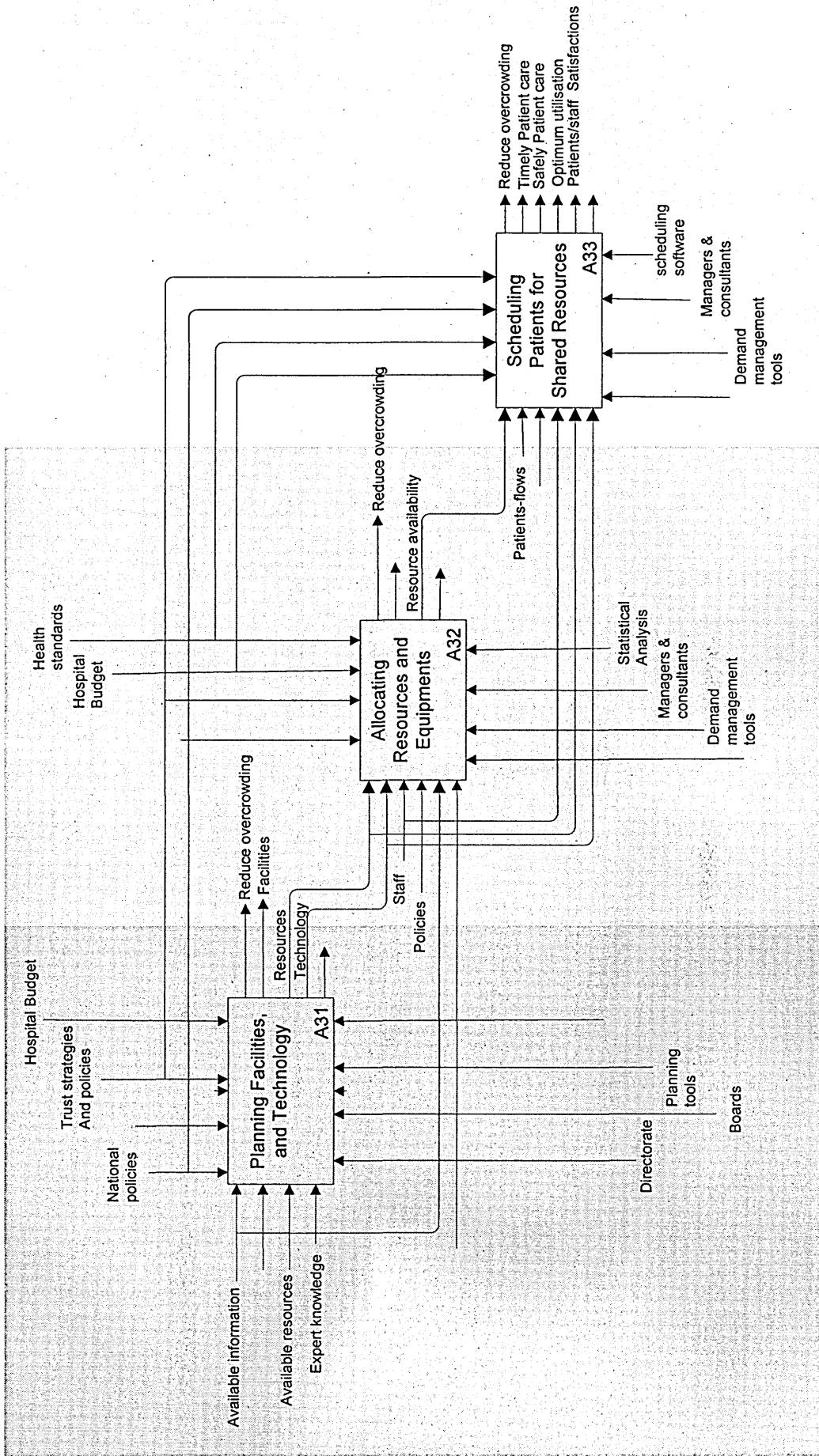

Figure 6.4 Facility, Resources & Technology Decisions in the Emergency Department

The simplified decisions-framework showing the two dimensions with the selected decisions is depicted in Figure 6.5. This decision-framework includes nine ED decisions reflecting the holistic decision-making process of a generic Emergency Department world-wide. These decisions are selected from each hierarchical decision-level in EDs covering all three categories earlier identified. These decisions are:

Strategic-level (long-term) Decisions

- Introducing new policy or changes
- Planning and recruiting workforce
- Planning facilities and technology

Tactical-level (medium-term) Decisions

- Improving ED process
- Scheduling staff
- Allocating resources and equipments

Operational-level (short-term) Decisions

- Managing patient-flows
- Scheduling patients for doctors
- Scheduling patients for shared resources

Even though there are some differences in ED settings in different countries, these selected decisions are common in any generic Emergency Department. Every Emergency Department faces challenges in making these decisions in an effective and efficient manner with limited resources and increasing demand. The following sub-chapters describe each decision in this framework separately under each level of decision.

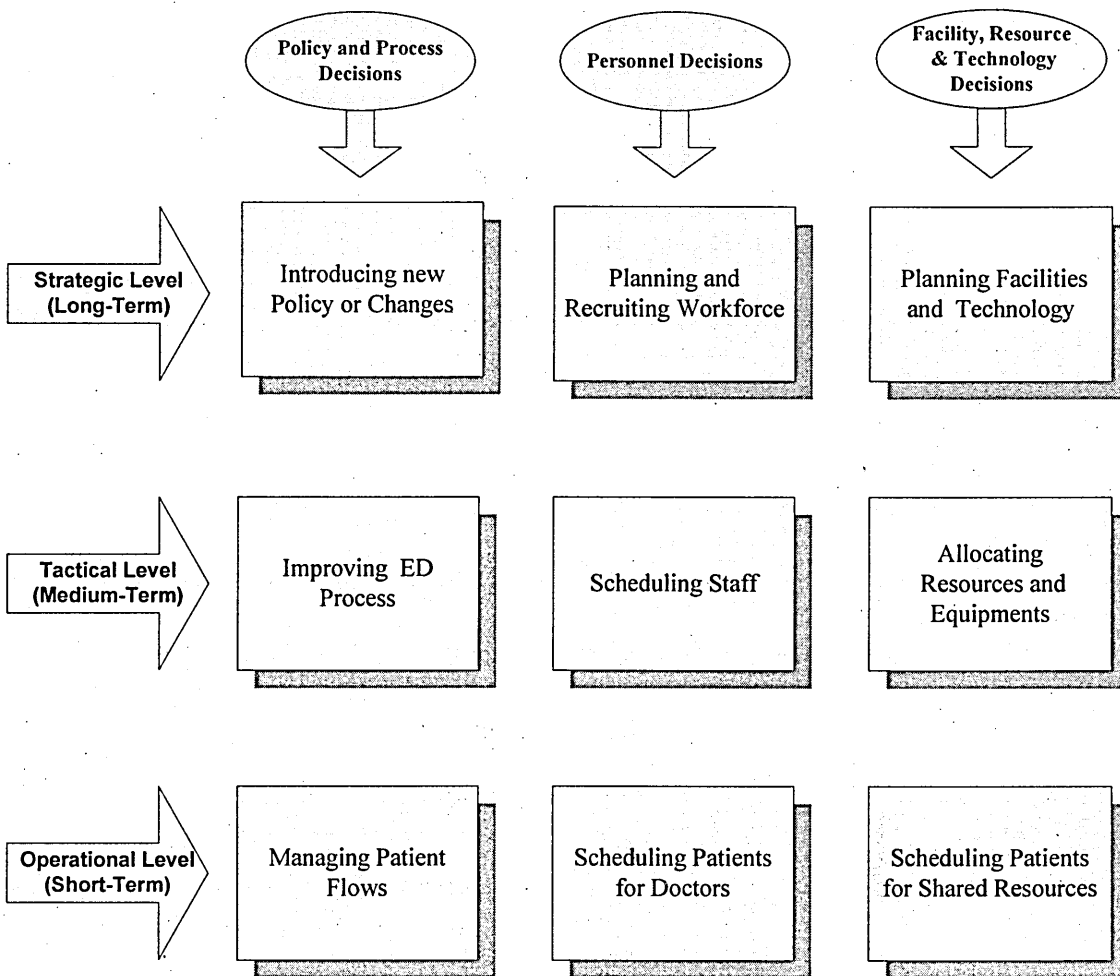

Figure 6.5 The Decisions-framework for the Emergency Department

6.3 Strategic-level (Long-term) Decisions

At this level of the framework, three strategic decisions are included covering all three categories of decisions explained in section 6.1.2. These three decisions are: introducing new policies or changes; planning and recruiting the workforce; and planning facilities and technology. The following sections discuss these decisions in detail.

6.3.1 Introducing New Policies or Changes

Various policies for hospital Emergency Departments are frequently introduced by the government and/or emergency-care decision-makers to improve care for patients. These

policies give major challenges to the hospital and Emergency Department management. For example, some of the government policies which have been introduced to the UK healthcare system in recent years are: Reforming Emergency Care in England; the European Working Time Directive; Modernising Medical Careers; The new Consultant Contract; and Keeping the NHS Local (England).

In addition to the government policies, the hospital and Emergency Departments themselves also introduce new policies within the department such as fast-track queuing, bed-side registration, new appointment systems, changing the methodology for assigning patients to beds, or implementing an electronic patient-record system to improve the patient-care and efficiency of the operations. Both kinds of policies will have a major impact on the whole emergency-care system and special implications for the Emergency Department. Most of the policy-changes introduced to the Emergency Department cannot be implemented without evaluation because of the high risks associated with failure. Therefore, before and after introducing such policy-changes, policy-makers need to carefully assess and evaluate the policy using appropriate tools and techniques.

The outcomes of introducing new policy depend on the policy introduced. The most common outcomes of this decision are: improving patient care, reducing overcrowding and waiting-times, increasing patient-satisfaction, reducing costs etc. For example, under the Reforming Emergency Care policy, the NHS Plan in 2000 set out the following targets for emergency-care (Department of Health, 2000).

- By December 2002 ambulance response-times will be improved so that an ambulance will respond to 75% of calls to life-threatening emergencies within 8 minutes.

- By 2003 75% of heart-attack patients will receive thrombolysis (clot-busting drugs) within 20 minutes of their arrival in hospital. Ambulance crews will also be trained to provide thrombolysis for appropriate patients before they arrive in hospital.
- By March 2004 all patients will see a GP within 48 hours, and other primary-care professionals within 24 hours.
- By 2004 no-one will wait more than 4 hours in an A&E department from arrival to admission to a bed in the hospital, transfer elsewhere or discharge. The average length-of- waiting should fall to 75 minutes.

6.3.2 Planning and Recruiting the Workforce

Appropriate staffing of the Emergency Department is the single most important factor in providing a prompt, timely and clinically-effective service to patients. All Emergency Departments within the UK have an establishment for medical and nursing staff with which to perform their activities. In 2005 the British Association for Emergency Medicine (BAEM, 2005) indicated in the “Way Ahead” document the appropriate medical staffing-levels necessary for UK Emergency Departments to carry out their core activity and achieve 90% of the four-hour target. Paw (2008) has undertaken a study to determine medical and nursing staffing-levels in Emergency Departments in England and Wales and concluded that there is great variability in staffing-numbers in similar-sized departments, and most departments are understaffed in comparison with the recommendations of the British Association for Emergency Medicine.

There are no national UK guidelines for Emergency Department nursing establishments, although Australia and parts of the USA have minimum nurse: bed ratios for Emergency Departments (Royal College of Nursing, 2003). Traditionally, the UK has

employed a bottom-up method for determining nursing-numbers which, while taking into account some measure of workload, is heavily dependent on some level of personal judgement by local managers. Victoria, Australia, has set into legislation a minimum level of one nurse per three patients plus a nurse in triage plus a nurse in charge of the whole Emergency Department. California has legislated that the maximum number of patients that can be looked after by a nurse in an Emergency Department at any one time is four, with a maximum of two critical-care patients or one trauma-patient. There are no guidelines or recommendations as to skill-mix and seniority and there is a dearth of research into the effect of skill-mix on patient-outcomes in the UK, although such work has been carried out in the USA where a positive relationship has been found between outcome and higher levels of trained Registered Nurses (Paw, 2008).

According to Paw (2008) the number of staff in the Emergency Department is influenced by local historical factors, trust priorities and finances, 4-hour targets, local activity profiles, staff-seniority, working-styles, availability of support-staff, ability to recruit staff, European Working Time Directives, changes in junior-doctor educational requirements, case-mix, patient-numbers and many other factors.

Workforce planning is the balance of demand for staff with its supply, to ensure that sufficient (but not over-sufficient) numbers of appropriately-qualified personnel are available in the right place and at the right time to match the demand for their services (Hall and Mejjia, 1998; O'Brien Pallas et al 2001; AHWAC, 2004). Determination of the appropriate number of medical staff and other employees has at least three dimensions:

- (1) The need to know how many physicians and nurses are required to serve the population at current service-levels.

(2) The need to know how many physicians and nurses are required to meet the expected needs of the population (including any needs not currently met).

(3) The need to know how many physicians and nurses will be required if the services are re-organised.

Since there is no widely-accepted method of determining the optimal number of medical staff, the need for appropriate tools will become increasingly important to the hospital and Emergency Department administration.

The outcome of the planning and recruiting of the workforce is simple. The aim of this decision is to maintain an optimum number of physicians, nursing and other staff in the department to provide a timely, and quality emergency-care to all the patients arriving at the department. The main outcomes of this decision are: reduced waiting-time and throughput-time; an increase in the quality of care; and increased satisfaction of patients and staff.

6.3.3 Planning Facilities and Technology

The healthcare providers frequently introduce new facilities and technology to the Emergency Department to improve its operations. The foundation of this introduction is typically driven by deficiencies and/or improving the current facilities that do not support new workflows or do not meet patient- or staff-needs. The continuing trend of increasing demand for emergency-care has put increased pressure upon hospital management to expand their services and/or to build new facilities to handle the increasing demand.

Expanding and/or replacing facilities presents many challenges to the Emergency Department managers. This decision typically has addressed the issues of how much capacity is needed and how and where these new facilities should be located. In

emergency-care systems, facility-size and location issues are particularly complex because of the interaction between the demand for services, workforce and technology. Hospitals must ensure old and new facilities are truly integrated in their technology solutions and systems, clinical process and other workflows as well as patient-flows and the overall patient-experience. Emergency Department facilities and the technology infrastructure must support the needs of all stakeholders: patients and visitors, physicians and nurses and other hospital staff. It essentially requires the appropriate tools and techniques to deal with these issues in planning the facilities and technology in the Emergency Department.

The main outcomes of this decision are: improving patient-care and safety, improving the ED performance and increasing patient- and staff-satisfaction.

6.4 Tactical Level (Medium-Term) Decisions

At this level of the framework, three tactical decisions are included covering all three categories of decisions explained in section 6.1.2. These three decisions are: improving the ED process; scheduling staff; and allocating resources and equipment. The following sections discuss these decisions in detail.

6.4.1 Improving the ED Process

In recent years, Emergency Departments across the world have faced problems with increasing healthcare costs that limit their ability to expand resources in order to cope with the increasing demand for care. As shown in Chapter 5, overcrowding in the ED has become an increasing problem, leading to frequent ambulance diversion, long waiting-times, poor patient-satisfaction, and increased risk to patient-safety. Faced with these problems, ED managers and other healthcare policy-makers are being forced to

search for ways to reduce costs and improve the efficiency and safety of care by improving the ED process. Radical analysis of industrial-processes over the last three decades has greatly improved the quality and efficiency of manufacturing and services. Similar methods to deliver higher quality and efficient emergency-care at a lower cost would be extremely valuable in the Emergency Departments.

The main outcomes of this decision are: identifying bottlenecks; optimal utilization of resources; a reduction in waiting-time and throughput-time; improved quality and safety of patient-care; and reduced costs.

6.4.2 Scheduling Staff

Medical staff is a limited, expensive and the most important resource in the Emergency Department. The scheduling of medical staffs is one of the most challenging problems for ED managers. There are two main types of medical staff (nurses and physicians) to be scheduled in ED. The most common scheduling-tool in healthcare is the electronic spreadsheet to create and edit their schedules.

According to Mullinax and Lawley (2002) scheduling staff in healthcare is very complex. Firstly, interrelations among highly-trained and skilled personnel who must be available at appropriate times for different patients. ED is unable to control the arrival and acuity-level of patients and must schedule their staff accordingly. Secondly, it is frequently difficult to measure the quality of work, especially in terms of successful patient-outcomes. The proper scheduling of staff significantly impacts on prompt, timely and clinically-effective patient-care and overall system-performance in ED.

The main outcomes of the decision are: optimum utilization of staff-resources; reduced patient waiting-times and throughput time; and increased patient- and staff-satisfaction.

6.4.3 Allocating Resources and Equipments

Emergency Departments use many limited, complex, expensive and essential resources and equipment apart from the human resources for the delivery of patient-care. All the resources and equipment used in Emergency Departments are presented in Appendix 1. With the rise in the cost of providing quality healthcare, hospital and ED administrators have approached cost-containment by minimising resources for healthcare provision while still striving to provide quality healthcare for patients. This predicament is becoming more prevalent in hospital and Emergency Department management and it requires appropriate tools and techniques to analyse the allocation of scarce healthcare resources and equipment in the Emergency Department.

The main outcomes of this decision are: optimal resource-allocation and utilization; reduced costs; reduced waiting-times; and improved ED performance and patient-care.

6.5 Operational Level (Short-Term) Decisions

At this level of the framework, three operational decisions are included covering all three categories of decisions explained in section 6.1.2. These three decisions are: managing patient-flows; scheduling patients for doctors; and scheduling patients for shared-resources. The following sections discuss these decisions in detail.

6.5.1 Managing Patient-flows

As discussed in Chapter 4, the patient-flows in the Emergency Department share four common characteristics: 1) an entrance; 2) an exit; 3) a path connecting the entrance to the exit; and 4) the random nature of the healthcare elements. Emergency Department patient-flow begins at the point when the patient first enters the Emergency Department. Likewise, after the admission to the hospital, when the patient leaves or is discharged

from the department are signals of the patient-flow's exit. Between these two points is a set of conditions, activities, services, or locations that the patient may encounter. Within these points, the patient requires a variety of healthcare resources (e.g. nurses, physicians, beds, examining-rooms, or medical procedures). Patient-flows are typical in Emergency Department settings, where patients arrive without appointments, and require treatment for a large and varied set of ailments and conditions. These ailments can range from the benign (in non-critical patients) to the fatal (in critical patients). For most Emergency Departments, 80% of their volume is considered non-urgent and therefore that volume would lend itself to more of a primary-care treatment. Though their arrival is highly-unpredictable, the sequence by which patients can be treated (that is, routed) can be controlled by medical staff. Busy Emergency Departments mainly handle three inflows of patients:

- 1) patients who do not need emergency-care but use the Emergency Room as their primary source of healthcare;
- 2) patients who need emergency services but do not require admission to the hospital;
- 3) patients who need emergency services and do require admission.

Historically, groups 1 and 2 have been at the mercy of group 3. The patients who required admission to the hospital presented the greatest challenge to Emergency Department flow. Most often, Emergency Departments divert some of these patients to other hospitals because their hospitals do not have the space to move patients forward (Committee on Government Reform, 2001; GAO, 2003).

The patient-flow management method, "See and Treat" is a popular approach in the UK (NHS 2004); and in the USA many hospitals have implemented "fast-track" systems (Rodi et al., 2006; Sanchez et al., 2006). Although the demand for the Emergency Department is a random process, it occurs repeatedly and can be forecast to some

degree with statistical-models. Managing the patient-flows is a big challenge for the Emergency Department managers and it requires appropriate tools and techniques to manage it efficiently.

The outcomes of this decision are: reduced risks; reduced waiting-time and boarding of patients; reduced ambulance diversion; a minimized number of patients leaving without treatment; improved throughput-time, optimal resource-utilization; and increased patient- and staff-satisfaction.

6.5.2 Scheduling Patients for Doctors

Patient-scheduling is a procedure for matching patients with medical staff within the Emergency Department both in terms of when and how they are set in a given day, and their length of time. Within the Emergency Department there are two main types of scheduling. That is inpatient-scheduling with care-givers (physicians, surgeons, specialists) and scheduling patients for revisit. More specifically, this involves rules that determine when appointments can be made and the length of time between appointments. This may also be extended to include designating the specific type of medical staff who will be responsible for treating patients and the ED space that will be required to deliver the necessary treatment. These issues can have a significant impact on how resources can be optimally utilised so as to maximise patient-flow without incurring the additional costs of excessive patient-waiting. Patient-scheduling rules along with patient appointment- timing can both have a significant impact on physician-utilisation and patient waiting- times. It requires appropriate tools and techniques for efficient scheduling of the patients for physicians in the Emergency Department.

The main outcomes of this decision are: increased staff-utilization and decreased staff idle-times; improved throughput-time; reduced waiting-time; and increased satisfaction of both patients and staff.

6.5.3 Scheduling Patients for Shared Resources

The Emergency Department uses many shared resources and equipment in the patient treatment-process. Sometimes it uses shared, limited, and expensive equipment where patients go through lengthy and periodic treatments and need to utilize that equipment efficiently. It is an important task to continue to treat current patients without any interruption along with incoming patients. Short access-time to those shared resources is crucial for high patient-throughput in the Emergency Department. The patients' needs have varying attributes, including their urgency, corresponding to the group they belong to. Allocating hired resources for individual patients like these is also a crucial operational-decision in an Emergency Department and it requires an appropriate tool to manage it efficiently.

The main outcomes of this decision are: improved resource-utilization; reduced risk; reduced waiting-time and throughput-time; and increased patient- and staff-satisfaction.

6.6 Validation of the Decisions-framework

After developing the decisions-framework, the researcher demonstrated it to the selected senior ED managers and consultants in England and conducted semi-structured interviews with them for the final validation of this framework. The schedule used for the interviews is given in Appendix 5. Eight experts, both from the ED managers and consultants expressed their opinion regarding the proposed the decisions-framework. The views expressed by them are as follows.

- 100% of ED managers and consultants are strongly agreed with the three decision levels in this framework.
- 75% of ED consultants and managers are agreed with the decision categories in the framework.
- 100 % of ED consultants and managers are agreed with the nine decisions selected for this framework.
- All the ED managers and consultants assured the requirement of suitable tool or technique in making the given decisions in the framework.
- The outcomes of some decisions are changed according to the opinions of the experts.

6.7 Summary

This Chapter developed an Emergency Department decisions-framework based mainly on the findings in Chapter 5. The decisions chosen are highly-related to the Emergency Department overcrowding problem and consider two dimensions of the decisions. One dimension is the level of decision: short-term, medium-term and long-term. The other dimension is the category of decisions based on the causes of overcrowding: policy and process decisions; personnel decisions; and facilities, resources and technology decisions. Altogether, nine ED decisions are discussed including the expected outcomes of each decision. Those decisions are: introducing new policies or changes; planning and recruiting the workforce; planning facilities and technology; improving the ED process; scheduling staff; allocating resources and equipment; managing patient- flows; scheduling patients for doctors; and scheduling patients for shared resources. The next chapter attempts to identify the possibility of using simulation and other systems-analysis tools successfully for the strategic-level decisions in this framework.

CHAPTER SEVEN

7. The Identification of Possible Tools for the Strategic Level Decisions in ED

This chapter analyses and discusses the possibility of using Discrete-event Simulation and three more tools in the strategic level (long-term) decisions in the decisions-framework explained in Chapter 6. The framework includes three strategic decisions: introducing new policy or changes; planning and recruiting the workforce; and planning facilities and technology. The analysis and discussion is carried out under each strategic decision based on the published relevant healthcare applications and literature reviews. In addition to Discrete-event Simulation at least one more technique is discussed under each decision as the alternative tools. At the end of the Chapter, there is a summary of the discussion with a matrix of possibilities to select the appropriate tools and techniques for strategic decision-making in EDs.

7.1 Introducing New Policy or Changes

This decision is described in detail, including the outcome of the decision, in Chapter 6.3.1. This section attempts to identify the possibility of using Discrete-event Simulation, Systems Dynamic, and Balanced Scorecards successfully in making this decision in EDs. The following conducts the analysis and discussion of each technique separately.

7.1.1 Discrete-event Simulation

Discrete-event Simulation can be helpful in many ways to the hospital and ED managers in introducing new policies to their Emergency Department. In the literature

there are a number of simulation-studies and applications in analysing policies introduced to the healthcare sector and Emergency Departments.

Ferrin et al. (2004) used Discrete-event Simulation to help St. Vincent's Hospital in Birmingham, Alabama, USA, to determine the value of implementing an incentive programme for their operating-room environment. The simulation showed that improving the room turn-around process by 20% would result in a 4% improvement in the operating-room's case-volume and a 5% increase in utilization of the same-day surgical rooms. This increase in volume provided enough increase in revenue to justify an incentive to improve the operating-room turn-around process.

Garcia et al. (1995) analyzed the impact of a fast-track queue on reducing waiting-times of low-priority patients in an Emergency Room using Discrete-event Simulation. A fast-track queue is used to treat non-urgent patients. They found that a fast-track lane that uses a minimal amount of resources could result in significantly-reduced patient waiting-times. A similar study to assess the effect of fast-care processing-routes for non-critical patients on waiting-times in an Emergency Department is presented by Mahapatra et al. (2003). This study showed that a fast-track unit improved average waiting-times by at least 10% using Discrete-event Simulation. Kraitsik and Bossmeyer (1993) suggested that patient-throughput can be improved using a fast-track queue and a "stat" lab for processing high-volume tests by using a Discrete-event Simulation model of the Emergency Department at the University of Louisville Hospital. Blake and Carter (1996) also successfully analyzed the implementation of a fast-track queue for treating patients with minor injuries in the Emergency Department at the Children's Hospital of Eastern Ontario using Discrete-event Simulation. Davies (2007) describes an evaluation of the flow of minor emergencies in an Emergency Department in the UK that had partially implemented "See and Treat" and managers were planning to

reorganize the department yet again to re-separate the activities of assessment and treatment. A Discrete-event Simulation indicated that the proposed system in which “See” and “Treat” were separated improved patient throughput and was likely to be more cost-effective.

Using Discrete-event Simulation, Ritondo and Freedman (1993) show that changing a procedural policy (of ordering tests while in triage) results in a decrease in patient waiting-times in the Emergency Room and an increase in patient-throughput. Edwards et al. (1994) compared the results of simulation-studies in two medical clinics’ policy that used different queuing-systems: serial-processing, where patients wait in a single queue; and quasi-parallel processing, where patients are directed to the shortest queue to maintain flow. They show that patient waiting-times could be reduced by up to 30% using quasi-parallel processing. Johnson (1998) developed a simulation model to represent the patient-flow and census at Miami Valley Hospital, Dayton, Ohio, US. This model also analyzed the effect of differing patient-types, increasing volumes, different Maternity Unit configurations, and policy-changes. The simulation-model showed that minor construction enabled a 15-20% increase in volume and more balanced overall utilization without changing the licensed capacity.

Johnson (1998) also used a MedModel Discrete-event Simulation model to examine the effect of new legislation (minimum-length-of-stay policy) and physician-practices on patient-flow and census of the Maternity Unit at Miami Valley Hospital in Dayton, Ohio, USA. The study led to some changes in the Maternity Unit configuration that resulted in a 15-20% increase in patient-volume and more balanced utilization of all areas within the unit. Gunal and Pidd (2006) presented a simulation of an Accident and Emergency Department to examine the effect of the four-hour waiting-time performance target policy on UK hospitals. Pressures on A&Es force the medical staff

to take action to meet these targets with limited resources. The model's output was the total times of patients in A&E and the percentage of patients who exceeded the 4-hour length-of-stay target. They also successfully used the Discrete-event Simulation to study the multi-tasking behaviour and experience-level of medical staff, both of which affect A&E performance.

The above wide range of successful Discrete-event Simulation applications in healthcare reveal that the Discrete-event Simulation can play a vital role in introducing new policy to the hospital Emergency Department. According to the above applications, Discrete-event Simulation has been successfully used to analyse different types of policy in healthcare such as introducing an incentive-programme, introducing fast-track queuing and additional patient-flows, changing procedural and clinical policy, and introducing a minimum-hours waiting-time policy. However, Discrete-event Simulation can be used at many stages in planning and introducing a new policy as follows:

- **Evaluating the alternative policies and selecting the preferred policy:** this is where a new policy is introduced to solve an existing problem in a system. In practice there may be more than one alternative method to solve a given problem. The policy-makers must carefully evaluate all the alternatives to select the best policy-decision to answer a particular problem. Discrete-event Simulation can be used at this stage to compare all the alternative policies and choose the best policy to address the particular problem.
- **Testing the outcomes of a policy:** Discrete-event Simulation can also be used to test the outcomes of a policy without suffering the added costs of enacting changes prior to knowing what effects they may have.
- **Evaluating the impact of the new policy:** introducing a new policy to the Emergency Department will impact on the entire emergency-care system.

Computer simulation can evaluate the impact of the policy on the system prior to the implementation and thereby mitigate care and financial risks.

- **Determining the resources needed to implement the new policy:** Before implementing a new policy it is necessary to determine the appropriate resources required to achieve the desired outcomes of the policy. Computer simulation can determine the resources required to implement and meet the targets of the policy.
- **Evaluating the implementation of the policy:** Computer simulation can also be used to evaluate the implementation of the new policy and it will help to keep the implementation on the right track.

Considering all the above, the researcher concludes that there is a high possibility of using Discrete-event Simulation successfully in introducing new policy to the Emergency Department.

7.1.2 System Dynamics

As explained in Chapter 2, Systems Thinking and System Dynamics modelling focus on understanding the structure of a system and how that structure impacts on behaviour over time. System Dynamics provides a framework by which we can understand dynamically-complex causal relationships. In addition to this, SD models can be constructed to test hypotheses of causal relationships and the effectiveness of indicators and policy to correct performance-deviations from targets (Linard, 2001; Akkermans and van Oorschot, 2002).

Royston et al. (1999) describe how the Operational Research group in the Department of Health in England has used System Dynamics modelling in several areas of healthcare policy and programme development and implementation. They outline

applications in disease-screening and in developing emergency-care. They also discuss the strengths and weaknesses found in its application and suggest some opportunities for its development and use in the future. According to this paper the Department of Health in England has used System Dynamics modelling in a wide range of policy and programme areas including: assessing public-health risks, screening for disease, managing waiting for hospital treatment, and developing emergency health and social care. Wolstenholme (1999) applies System Dynamics to the development of national policy guidelines for the UK Health Service. A model of total patient-flow through the UK National Health Service is developed and used to test alternative major new structural initiatives for relieving pressure on Health Services. The policies tested include the use of "Intermediate Care" facilities aimed at preventing patients needing hospital treatment or Continuing and Community Care. Intermediate Care, together with reductions in the overall length-of-stay of all patients in Community Care made possible by its use, is demonstrated here to have a much more profound effect on total patient waiting-times than more obvious waiting-time solutions, such as increasing acute hospital-bed capacity. The results of the model provide a clear demonstration that adjustments to "flow" (throughput) variables in a system provide significantly more leverage than adjustments to "stock" (capacity) variables.

According to Patrick (2005) System Dynamics can effectively model the integrated policies leading to broad, dramatic improvements in health-system performance. Lane et al. (2000) have undertaken a System Dynamics study to explore the factors which contribute to the delays in Emergency Departments. This study discusses the formulation and calibration of a System Dynamics model of the interaction of demand pattern, ED resource-deployment, other hospital processes and bed-numbers; and the outputs of policy-analysis runs of the model which vary a number of the key

parameters. According to Lane et al. (2000) two significant findings have policy implications. One is that while some delays to patients are unavoidable, reductions in delays can be achieved by selective augmentation of resources within, and relating to, the Emergency Department. The second is that reductions in bed-numbers do not increase waiting-times for emergency admissions, their effect instead being to increase sharply the number of cancellations of admissions for elective surgery. Hirsch et al. (2005) examined potential types of reform and the history of reform efforts in the USA healthcare system using System Dynamics. Causal-loop diagrams are presented which together comprise a theory to explain what created the set of problems that exist, and why efforts at reform have largely failed. In this paper different philosophical bases for reform and the need for an eclectic approach are discussed, and a sequential “bootstrapping” approach to comprehensive reform is outlined. The diagrams and discussion of this paper are intended as a starting-point for further collaborative work on healthcare reform among System Dynamics practitioners and health policy experts, leading to simulation modelling and further insights.

The culture of the healthcare system leads to a focus on individual patients and this generally predominates in studies within the Emergency Department. As with all modelling approaches, the application of System Dynamics produces losses as well as gains. Examples of the former are the loss of the effects of stochastic variation and of resolution down to individual patient or condition level. However, the gain, put simply, is that considering aggregated variables encourages both a systemic view of the interactions of patient-flows and information, and a more strategic perspective of the management of the system. It is widely accepted by healthcare professionals that healthcare provision cannot be understood by looking at factors in isolation. By encouraging the study of how different processes interact to produce effects, System

Dynamics offers a rigorous approach for bringing that interconnectedness insight into focus.

Even though it was difficult to find straight-forward System Dynamics applications in introducing new policy to the Emergency Department, the above review of System Dynamics studies and applications in healthcare and the concept of SD analysis (see Chapter 2) reveal that there is a high possibility of using the SD successfully as a modelling-tool in introducing new policy to the Emergency Department. The Emergency Department is not operating in isolation. It interacts with many other sub-systems. Introducing a new policy to the Emergency Department affects the entire hospital-system. Systems Dynamics can play a vital role in understanding those effects on each sub-system arising from the introduction of a new policy in the Emergency Department.

7.1.3 Balanced Scorecards

According to Zelman, Pink et al. (2003), the BSC has been adopted by a broad range of healthcare organisations, including hospital-systems, hospitals, psychiatric centres, and national healthcare organisations. Since 1994, when the first refereed article was published on BSC in healthcare settings, numerous articles have appeared in the Health Services and Management literature.

As explained in Chapter 2, the Balanced Scorecard provides continuous feedback to leaders on internal management processes and outcomes to improve system results. In contrast to the traditional model in healthcare, where a problem is identified when there is a policy-error or a poor outcome is recognized, the Balanced Scorecard provides continuous monitoring and analysis of performance by using agreed-upon measures of efficiency and care-standards.

In healthcare, much of the literature relates to how to apply BSC successfully (for example, Chow, Ganulin et al. (1998); Stewart and Bestor (2000); Pink, Mckillop et al. (2001); Oliveira (2001); Fitzpatrick (2002); Shutt (2003); Tarantino (2003); Radnor and Lovel (2003a) and (2003b)). Zelman, Pink, and Matthias (2003) have found that rural hospitals in USA were using Balanced Scorecards to modernize their facilities. Oliveria (2001) found that patients' satisfaction improved and the rate of patient-complaints decreased after implementing a BSC. Pineno (2002) developed an incremental modelling approach to link the following performance-measures as part of a hospital Balanced Scorecard: financial performance, efficiency, liquidity, capital, process quality, outcomes, clinical quality, number of hospital partners, housekeeping, information use, coordination of care, community linkages, re-admissions, length-of-stay, complications, surgery-rates, and procedure-rates.

However, the Scorecard lacks a rigorous means for the selection and validation of performance-indicators and policy-decisions which respond to performance-gaps (Linard, 2001). Typically, indicators for the Scorecard are chosen by consensus among the stakeholders, and it is further assumed that presenting decision-makers with information on the Scorecard will lead to good decision-making. This is not necessarily so, especially when faced with the dynamically-complex problems of managing organisational-performance.

Similar to other profit-oriented business and service organizations, Balanced Scorecards can be used by the hospital's Emergency Department at the policy-implementation level in many ways: to clarify, and gain consensus about, policy changes; to communicate policy throughout the organization; to align departmental and personal goals to the new policy; to link policy-objectives to long-term targets and annual budgets; to identify and

align policy-initiatives; to perform periodic and systematic strategic-reviews; and to obtain feedback to learn about, and improve, strategy.

A full BSC system could be developed as a diagnostic control-system to improve the achievement of Government-based targets. Even if the BSC could not quickly improve service-efficiency, it would still offer significant benefits in terms of meeting government expectations and targets for enhanced transparency, clarity, accountability to the public/patients, and involvement of/support for staff. Despite the fact that the BSC is unable to use in all the stages in introducing policy, the above review and the nature of the BSC reveal that it can be used as a powerful tool at the stage of implementation of new policies within the Emergency Department by keeping the expected performance of a policy on track. By considering all these aspects the researcher concludes that there is a moderate possibility of using the BSC successfully in introducing new policy to the Emergency Department.

7.2 Planning and Recruiting the Workforce

This decision is described in detail, including the outcome of the decision, in Chapter 6.3.2. This section attempts to identify the possibility of using Discrete-event Simulation and Queuing Theory in the making of this decision in Emergency Departments. The following sections conduct an analysis and discussion of each technique separately.

7.2.1 Discrete-event Simulation

In the past a number of Discrete-event Simulation studies were undertaken where the technique was used to determine the staff-size or the numbers of physicians and nurses in healthcare and the Emergency Department. Baesler et al. (2003) used Discrete-event Simulation and various experiments to predict a patient's time spent in the Emergency

Room and to minimize the number of full-time and part-time physicians required to meet patient-demand in a private hospital in Chile. Ishimoto et al. (1990) also successfully used discrete-event simulation to identify the optimal medical staff-size and mix that reduces patient waiting-times in a hospital pharmacy. Weng and Houshmand (1999) simulated a general-hospital outpatient-clinic in USA to find the optimal staff- size that maximizes patient-throughput and minimizes patient-flow time.

Swisher et al. (2001) discussed a Discrete-event Simulation model of the Queston Physician Practice Network where individual family outpatient-clinics are modeled. They analyzed the performance-measures such as patient-throughput, patient waiting-times, staff-utilization, and clinic-overtime for various numbers of exam-rooms and staff-mixes. They found that, in certain cases, adding support-personnel had negligible effects on the performance-measures. Centeno et al. (2000) conducted a simulation study of the radiology department at JMH and discussed six different scenarios that vary staff and physical resources. These were studied to determine the impact on patient-flow and utilization of the department-staff and operating-rooms. This study determined the most cost-effective staff-level for each procedure and identified additional revisions to improve process and service-efficiencies. Klafehn and Connolly (1993) modeled an outpatient hematology laboratory and compared several configurations. They observed that if the staff were cross-trained (and hence, could be more fully utilized), patient waiting-times could be reduced.

According to the above simulation-applications, it is clear that Discrete-event Simulation is an effective tool to determine how many, and what type of, staff are required for current, future and re-organized different-sized Emergency Departments to keep the expected outcome of the decision at optimal level.

7.2.2 Queuing Theory

Green (2006a) surveyed the contributions and applications of Queuing Theory in the field of healthcare. According to him, Queuing Theory has been directly applied in planning the staff in healthcare. Gupta and Kramer (1971) undertook a study to plan the hospital manpower by use of Queuing Theory. Lucas et al. (2001) used the Queuing Theory to define optimum operating-room staffing-needs for a trauma centre in the USA. Tucker et al. (1999) determined operating-room staffing-needs using Queuing Theory to provide optimal service while minimizing waiting at Stamford Hospital USA. Khan and Callahan (1993) also used a queuing-model to plan hospital laboratory staffing.

The above studies show that Queuing Theory also has been successfully used in planning and recruiting the work-force in different healthcare organisations that are similar to the Emergency Department. But, considering the limitations of Queuing Theory as a mathematical modelling tool, the researcher concludes that it is a moderate tool in planning and recruiting the staff in a hospital Emergency Department in comparison with Discrete-event Simulation.

7.3 Planning Facilities and Technology

This decision is described in detail, including the expected outcome of the decision, in Chapter 6.3.3. In this section, the researcher attempts to identify the possibility of using Discrete-event Simulation and Queuing Theory successfully in making this decision in the Emergency Department. The analysis is conducted separately for each technique as follows.

7.3.1 Discrete-event Simulation

Over the past few decades, a number of Discrete-event Simulation studies can be found in planning facilities in healthcare and emergency-care. Kuzdrall et al. (1981) used a simulation model of an operating and recovery room facility to determine and assess the facility utilisation-levels and facility-needs under different scheduling policies. Olson and Dux (1994) applied simulation-modelling to study the decision to expand the Waukesha Memorial Surgical-centre from seven to eight operating-rooms. The study revealed that an eighth operating-room would only serve to meet the hospital's needs for one to two years, at a cost of \$500 000. However, an analysis of the cross-departmental and administrative needs revealed that an ambulatory surgery centre that separated the inpatient and outpatient procedures would better serve the hospital's future healthcare delivery-needs. Likewise, Amladi (1984) used simulation to assist in the sizing and planning of a new outpatient surgical-facility, by considering patient waiting-times and facility-size.

Meier et al (1985) considered eleven scenarios varying the number of examination-rooms and shift-demands of both a hospital ambulatory centre and a freestanding surgical-center. They found that existing room-capacity was adequate to handle the demands for the next five years. Iskander and Carter (1991) also found that current facilities were sufficient for future growth in a study of a same-day (outpatient) healthcare unit in an ambulatory-care centre. However, they suggested a threefold increase in the size of the waiting-room. Kletke and Dooley (1984) examined the effects on service-levels and utilisation-rates in a maternity ward to determine if the current number of labour-rooms, delivery-rooms, postpartum-rooms, nurseries, and nurses were able to meet future demands. Their simulation-study recommends increasing the number of labour-rooms and the number of post-partum rooms, while maintaining four

full-time nurses. Miller et al. (2004) developed a simulation-model which enabled the hospital to test design ideas for a planned new facility.

Sepulveda et al. (1999) use Discrete-event Simulation to evaluate improvements in patient-flow at a cancer treatment centre under three different scenarios featuring: 1) a change in the layout of the clinic; 2) different patient-scheduling options; and 3) a new facility with increased capacity. The simulation of all three scenarios identified key patient-flow bottlenecks and provided insights to improve patient-flow and utilization. In particular, under the layout-scenario, the simulation was used to identify a facility layout that allowed for a 100% increase in chair-capacity. Simulating different patient-scheduling options showed a 20% increase in the number of patients seen per day, without any change in the operating-times of the treatment centre. Finally, the new facility scenario showed that one of the waiting-rooms did not have the capacity to support patient-flow.

Ramakrishnan et al. (2004) described a Discrete-event Simulation model used to analyze different scenarios for the Wilson Memorial Regional Medical Centre in Broome County, New York USA. The centre had recently implemented a digital image archiving system within its Radiology Services department, and with this implementation wanted to identify patient-flow changes in the Computerized Tomography (CT) scan area that would maximize patient-throughput and minimize report-generation time. Using simulation, the researchers identified changes within the CT scan area that would increase patient-throughput by 20%, while simultaneously reducing report-generation time by over 30%.

In 1997 Brigham and Women's Hospital (BWH) in Boston initiated a construction project to renovate its existing surgical-suite to include 32 operating-rooms: two less

than the current number. The new suite would be used for performing primarily inpatient cases; 95% of all outpatient cases would be moved to another facility. BWH administrators, planners, and clinicians wanted to be sure that the 32 rooms would be sufficient for accommodating projected increases in the inpatient surgical-volume. In addition, they wanted to examine the possible effects of changes in the surgical-schedule and in case-times on the number of rooms required. Lowery and Davis (1999) developed a DES model to examine these issues and showed that the projected changes in surgical-workload could be accommodated in 30 operating-rooms if scheduled block time were extended during the weekdays and Saturday blocks were added.

Rossetti et al. (1998) used Discrete-event Simulation to study clinical laboratory and pharmacy delivery-processes in a mid-sized hospital environment. The study specifically assessed the costs and performance benefit of procuring a fleet of mobile robots to perform delivery-functions. The study found that a fleet of six mobile robots improved the turn around time by 33% and reduced costs by 56% compared to the current system of three human couriers. Similarly, Wong et al. (2003) used simulation to quantify the advantages of an electronic medication ordering, dispensing, and administration process at an academic acute-care centre. The automated system had an average turn-around time of 123 minutes versus the existing manual system turn-around time of 256 minutes. Groothuis et al. (2002) described a systematic approach for analyzing the effects on patient-flow when a hospital department is relocated. This approach was demonstrated with a MedModel simulation-model of relocating a hospital phlebotomy department, which assessed the resulting impact on the average patient-turn-around time. They observed that this time could be reduced by as much as 50%. Johnson (1998) also used DES to model the patient-flow and census of the Maternity Unit at Miami Valley Hospital in Dayton, Ohio, USA and its results supported decisions

to construct new facilities, such as a larger perinatal intensive-care unit. Ashby (2007) utilized simulation to determine optimal resources, routing, and timing for the movement of almost 600 inpatients from two different facilities to a new replacement facility. Potential resource constraints of specialized move-teams, ambulances, and other staffing-constraints were explored to predict and reduce the likelihood of complications during the two-day patient-move.

Ramakrishnan et al. (2004) analyzed flows in a teaching hospital USA that was implementing a digital image-archiving system within its radiology services. Process mapping was used to identify the initial flow of operations, and a DES was built to evaluate the different scenarios. They identified changes to the existing workflow at the CT scan area that would maximize patient-throughput and minimize report-generation time with the digital system. Mahapatra et al. (2003) developed a Decision-support System (DSS) using the Emergency Severity Index (ESI) triage method to drive improvements in the care-delivery process for an academic ED in York Hospital, Pennsylvania. The DSS paired the ESI case-mix with simulation to support resource-deployment, improve service-metrics, and support strategic decision-making. Rossetti, et al. (1998) discussed the use of DES to analyze the costs, benefits, and performance tradeoffs related to the installation of a fleet of mobile robots within mid-sized hospital facilities, in lieu of human carriers. Results showed that for clinical laboratory deliveries, a fleet of six mobile robots could achieve significant performance-gains over the current system of three human couriers, while remaining cost-effective.

The above simulation studies and applications in ED and similar healthcare operations reveal that the Discrete-event Simulation can be used in many ways in ED to enhance the outcomes of this decision, helping an understanding of how facilities and technology can create efficiencies and increase the quality of patient-care. They further reveal that

DES can be used to enhance the ED decision-maker's ability in planning the facilities and technology to find the most cost-effective and efficient solutions to provide quality and prompt patient-care and remain competitive.

7.3.2 Queuing Theory

Using the Queuing Theory, Koizumi et al. (2005) found that blocking in a chain of extended-care, residential and assisted-housing facilities results in upstream facilities holding patients longer than necessary. They analyzed the effect of the capacity in downstream facilities on the queue-lengths and waiting-times of patients waiting to enter upstream facilities. They also found that system-wide congestion could be caused by bottlenecks at only one downstream facility. Roche et al. (2007) found that the number of patients who leave an Emergency Department without being served is reduced by separating non-acute patients and treating them in dedicated fast-track areas. Most of their waiting would be for tests or test results after having first seen a doctor. Using Queuing Theory they estimated the size of the waiting-area for patients and those accompanying them.

Although Queuing Theory models have been used to address many healthcare issues, the facilities and technology planning applications are rare. Despite the capability of modelling uncertain demand for the ED facility, the researcher concludes that there is only a moderate possibility of using Queuing Theory successfully in facilities and technology planning in the Emergency Department due to its own limitations in analysing dynamically-complex situations like ED.

Table 7.1 Matrix of the Strategic Level Decisions in ED and Possible Tools

Decision	Discrete-event Simulation	System Dynamics	Queuing Theory	Balanced Scorecards
Introducing a new policy and changes	H	H	L	M
Planning and recruiting workforce	H	L	M	L
Planning facilities and technology	H	L	M	L

H= High, M= Medium, L= Low
(Possibility of successfully using these tools for decision-making)

7.4 Summary

This chapter attempted to identify the possibility of using Discrete-event Simulation, and three more techniques successfully in strategic-level decision-making in the Emergency Department. The discussion is mainly based on the comprehensive analysis of published studies and applications in EDs and similar healthcare cases. There are numerous successful Discrete-event Simulation applications under each strategic-level decision. In the light of this analysis, Table 7.1 presents the possibility-matrix to select appropriate tools and techniques for each strategic decision considered in this framework. The analysis reveals that there is a high possibility (H) of successfully using DES in all three decisions considered in this section. In addition to DES, there is a high possibility (H) of successfully using System Dynamics in introducing a new policy to the Emergency Department. But System Dynamics is not a suitable tool to use in other two decisions in this framework. As a mathematical modelling-tool Queuing Theory can be used as a moderate (M) tool in two decisions, i.e. planning and recruiting the workforce, and planning facilities and technology. But Queuing Theory is not a

viable modelling-tool to use for the decision about introducing new policy to the ED. According to the findings of this analysis, Balanced Scorecards can be used as a moderate tool (M) at the implementing stage of new policy in the Emergency Department. But it has less possibility of successful use in other decisions considered in this section. In the light of this analysis, the researcher concludes that Discrete-event Simulation is the most suitable modelling-tool in the strategic-level (long-term) decision-making in the Emergency Department. Next chapter attempts to identify the possibility of using the simulation and other system analysis tools for the tactical level decisions in the framework.

CHAPTER EIGHT

8. The Identification of Possible Tools for the Tactical Level Decisions in ED

The previous chapter indentified the possibility of using DES and three more tools in strategic-level decision-making in the ED. This chapter attempts to identify the possibility of using Discrete-event Simulation and three more tools and techniques in the tactical-level (medium-term) decisions in the framework described in Chapter 6. The framework includes three medium-term decisions; Improving the ED process, scheduling staff, and allocating resources and equipment. The analysis is carried out under each decision based on the published relevant healthcare applications and literature reviews. In addition to Discrete-event Simulation, at least one more technique is discussed under each decision as alternative tools. At the end of the chapter, there is a summary of the discussion with a possibility-matrix to help choose the appropriate tools and techniques in the medium-term decision-making in the ED.

8.1 Improving the ED Process

The decision improving the ED process is discussed in detail, including the expected outcome, in Chapter 6.4.1. This section analyses the possibility of using Discrete-event Simulation, Lean and Six Sigma, and System Dynamics in the making of this decision. The following sections conduct the analysis and discussion under each technique separately.

8.1.1 Discrete-event Simulation

A number of successful simulation-based process-improvement studies and applications in healthcare and emergency-care can be found. ProModel Corporation (2009) used a

Discrete-event Simulation model for Baystate Hospital in the USA and was able to achieve the following benefits: a reduced length-of-stay in the main ED by 15%; a reduced length-of-stay in the GTA (fast-track) by 33%; and an indefinite postponement of the ED expansion, avoiding a \$1.2 million investment, and disruption to critical operations. Furthermore, the estimated increase in patient-admissions and throughput capabilities revealed the potential for an additional \$900,000 in annual revenue for Baystate hospital.

An entire Emergency Department of a general hospital is simulated to examine patient-flows by Takakuwa (2004). He found that patients spend the longer part of their time waiting, depending on the number of patients to be processed. In addition, he found that the waiting-time for available emergency-treatment beds, doctors, drips, and stretchers accounted for the major part of all the waiting-time in the Emergency Department. This study proposed a stepwise procedure of operations-planning to minimize the patient waiting-times, and numerical examples are shown to illustrate the procedure. Stephanie et al. (2005) built a simulation-model for the University Medical Center's Emergency Department (ED) in Tucson. The purpose of this project was to decrease overall patient throughput-time by identifying potential bottlenecks and proposing strategies to alleviate them. The analysis results and proposed alternative solutions of this project were presented to ED administrators who were tasked with making the final decision.

Christine and Chetouane (2007) undertook a Discrete-event Simulation study of an Emergency Department at a regional hospital in Canada to reduce patient waiting-times and to improve overall service-delivery and system-throughput. As patient waiting-times are linked to resource-availability, a number of alternatives were designed based on adding resource-scenarios. The simulation showed that waiting-duration from registration to available exam-room was the most problematical. Five alternatives were

formulated based on adding staff and exam-rooms within budget limitations. The alternative with one physician and nurse added from 08.00 to 16.00 hours gave the best improvement-level for waiting-times. It allowed treating an additional number of 16 patients between 08.00 and 20.00 hour. The simulation showed that the number of examination rooms had no effect on waiting-times if added without a matching increase in the staff. A number of qualitative suggestions were also formulated based on their experience with the process. Komashie (2005) developed a Discrete-event Simulation model to help the Emergency Department managers understand the behaviour of the system with regard to the hidden causes of excessive waiting-times. The results of this work also helped managers to either reverse or modify some proposed changes to the system. The results also showed a possible reduction of more than 20% in patients' waiting-times. Miller et al. (2004) describes a re-usable product called EDsim which was developed to model and test alternative ED design-scenarios. This product responds to the need by hospital administrators to improve key performance-indicators, such as patient LOS, bed-utilization, and the elimination of bottlenecks. Ferrin et al. (2007) used Discrete-event Simulation to improve the ED process in Carondelet St. Mary's Hospital, USA. They worked to improve hospital-flow and increase access to care by implementing process-improvements based on simulation that reduced the Emergency Centre length of stay by 7%, increased the monthly volume by 5%, increased the inpatient daily census by 20% and improved the hospital net-operating margin by 1.3% above budget. The paper demonstrated simulation's unique ability to direct improvement-efforts for maximum impact operationally, financially and for the best benefit of the patient.

There are many more successful simulation-studies related to process-improvement and reducing waiting-times in the hospital Emergency Department and those applications

are summarised as follows. Samaha, et al. (2003) reported a study conducted for the ED at Cooper Health System in southern New Jersey. The simulation-model depicted current operations and was used to evaluate concepts for reducing LOS for ED patients. McGuire (1994) used MedModel to determine how to reduce the length-of-stay for patients in an emergency-service department in a SunHealth Alliance hospital. Miller et al. (2003) used a Discrete-event Simulation of the Emergency Department of a large hospital in the southeast United States to show that significant process-changes would be required to meet specified goals for patient length-of-stay. Blasak et al. (2003) presented a Discrete-event Simulation study of patient-flow to reduce the Emergency Department length-of- stay. Boxerman (1996) proposed the use of simulation-modelling as a powerful tool for testing alternatives and process-improvement. Baester et al. (2003) developed a simulation-model to estimate the maximum demand-increment that could be sustained by the Emergency Room of a private hospital in Chile, without increasing the waiting-time beyond an acceptable level.

In addition to the ED applications, there are some successful process-improvement cases in similar healthcare places. Sepúlveda et al. (1999) used Discrete-event Simulation to improve the process of a full-service cancer treatment centre in the USA. The results of this analysis showed that important improvements in patients' flow-time could be achieved. This analysis showed that the number of patients seen per day could be increased up to a 20% without materially affecting the closing-time of the facility. The simulation-model provided strong justification to relocate the centre's laboratory and pharmacy as well as identifying changes in scheduling procedures that would allow a 30% increase in patient-throughput with the same resources. The results also showed that one of the waiting rooms did not have sufficient capacity to support the flow of

patients. In addition to these results, all the simulated scenarios were used to identify bottlenecks and to analyze patient-flow and operating-efficiency.

After carefully reviewing the above Discrete-event Simulation application, the researcher identified that most of the applications have successfully achieved many improvements in their processes by using Discrete-event Simulation. The common elements of the achievements of these studies are: reduced waiting-times; the identification of the hidden causes of excessive waiting-times; an increase in patient-admissions and throughput with the same resources; the identification of bottlenecks and proposal of strategies to alleviate them; the identification of process-changes required to meet specified goals; an increase in annual revenue; and reduced costs. These achievements gained in the above application strongly suggest that Discrete-event Simulation is an invaluable tool in improving the process in the Emergency Department of a hospital.

8.1.2 System Dynamics

Although, there has been an explosion in the use of System Dynamics modelling in healthcare over the past decade, only a few applications in process-improvement have been published. Brailsford, S. C. (2008) illustrated this tool with several examples in the field of healthcare, and discussed some of the possible reasons for the growth in the popularity of the System Dynamics approach for healthcare-modelling. Lattimer et al. (2004) described the components of an emergency- and urgent-care system within one Health Authority in the UK and investigated ways in which patient-flows and system-capacity could be improved using a qualitative and quantitative System Dynamics approach. A conceptual-map patient-pathway from entry to discharge was used to construct a quantitative SD model populated with demographic and activity data to simulate patterns of demand, activity, contingencies, and system-bottlenecks. This

modelling showed the potential consequences of continued growth in demand for emergency-care, but also revealed considerable scope to intervene to ameliorate the worst-case scenarios, in particular by increasing the care-management options available in the community. Koelling and Schwandt (2005) said that the opportunities that exist to apply System Dynamics modelling in health-systems performance-improvement start with the qualitative models developed by Hirsch et al. (2005). Focusing on the U.S. Health System, Hirsch et al. (2005) demonstrated the potential benefits of System Dynamics and concluded that increased utilization of System Dynamics modelling can contribute to significant structure-based performance-improvement. They correctly stated that a key avenue of research is to build from their causal-loop diagrams, adding the necessary stock and flow data to support quantitative analysis. In addition, the strengths of Discrete-event Simulation have been exploited to generate improvement opportunities. However, research indicates that even more benefits can be obtained by efficiently and effectively integrating SD and DES models to take advantage of the strengths of both techniques.

According to these few studies, it is clear that SD modelling is more appropriate for studying the inter-relations between an Emergency Department and the rest of the healthcare systems. The above studies also suggest that the integration of Discrete-event Simulation and System Dynamics have great potential to become an important decision support-tool for dealing with internal efficiency-issues within the ED walls, as well as helping with system-wide factors beyond the immediate control of the ED managers. SD combines qualitative and quantitative aspects and aims to enhance understanding of a system and the relationships between different system-components. However, in general SD models do not produce highly-detailed numerical results, since its purpose is to generate understanding and insight into a system, rather than acting as a precise

predictive tool. By considering all these aspects the researcher concludes that SD can be used successfully as a moderate process-improvement tool in the Emergency Department.

8.1.3 Lean and Six Sigma

Over the past few years, two methodologies for process-improvements in manufacturing and service-operations have been coming to healthcare. These methods include Lean thinking, which seeks to eliminate activities or process-steps which do not add value to customers; and Six Sigma, which aims to reduce variations and create defect-free services. There are a number of successful studies and applications using these two methods in health- and emergency-care organisations in the past.

Lean and Six Sigma is a proven approach to reduce defects and waste and improve processes, thus saving money in industrial, service, retail, and financial organizations. Several case-studies on Lean and Six Sigma initiatives in the healthcare sector also can be found. Two healthcare organizations in the US showed a positive impact on productivity, cost, quality, and timely delivery of services after having applied Lean principles throughout the Measuring Lean Initiatives organization (Miller, 2005). In Rogers et al. (2004), a medical director at the NHS Modernization Agency in the UK claims that the key elements of Lean Thinking have been applied in service improvement-programmes for several years, and successful outcomes have been shown in applying them to, amongst others, emergency-flows and journey-times in cancer-care.

Hagg et al. (2007) have successfully applied Lean Six Sigma methodologies to improve turn-around times for Emergency Department STAT² orders within 3 hospital labs

² STAT is a medical term which means urgent or rush.

through application of a Lean Six Sigma training programme. As a result of this programme, the collection to report-processing times for ED STAT specimens has decreased from an average of 75 minutes to less than 35 minutes. Additionally, this paper discussed the strategies and methodologies used to sustain initial results following the initial implementation, and the key characteristics of successful project-migration to additional hospital labs. Young et al. (2004) saw an obvious application of Lean Thinking in healthcare in eliminating delay, repeated encounters, errors and inappropriate procedures. They suggested the classification of conceptual issues, and in particular which stakeholders can be identified as customers. Similarly, Breyfogle and Salveker (2004) advocated Lean Thinking in healthcare and gave an example of how Lean management principles can be applied to healthcare processes through the use of the Six Sigma methodology, which in many ways resemble the Lean production techniques.

Komashie et al. (2005) conducted a study of an ED in a British hospital, with the objective to determine the impact of key resources (doctors, nurses, beds) on key performance-measures (waiting-times, waiting-queues and patient-throughput). The designed Arena model contains several features such as variable service-times to model nurse- and doctor-ranking along with patient-condition-based treatment-durations. A different arrival-process was used for each day of the week. Data for this study were collected by means of Hospital log-sheets, interviews, and on-site observations. Khurma et al. (2008) attempted to improve the patients' experience over their ED stay by using a combination of Lean tools to analyze, assess and improve the current situation. They developed a simulation-model based on current and future states of ED and a comparative analysis of both enabled the verification of the feasibility of proposed solutions, and provided quantifiable results. Their paper addressed some of the waste in

the ED process, including transportation, over-processing, waiting, motion etc. To deal more effectively with different types of waste in the process, they applied Lean methodology techniques in order to understand the current state, develop an improved state of the process, identify the gaps and prioritize the activities.

The successful Lean and Six Sigma studies in health and emergency-care reviewed above prove that these methods can be widely-used in improving the Emergency Department process and safety of care. The applications showed a positive impact on productivity, costs, quality, and timely delivery of care in many cases after having applied Lean and Six Sigma. Some of the studies have successfully eliminated delay and waste in the ED process including transportation, over-processing, repeating, waiting, motion, inappropriate procedures, errors etc. One study has used these methods to understand the current state and an improved state of the process, and to identify the gaps and prioritize the activities. Another application reports that processing-times for ED have been decreased from an average of 75 minutes to less than 35 minutes. After a careful review of these successful applications in healthcare, the researcher concludes that there is a high possibility of using Lean and Six Sigma methods successfully in improving the process in ED. However, a successful implementation of Lean and Six Sigma methods require long-term vision, commitment, leadership, management, and training.

8.2 Scheduling Staff

This decision is described in detail, including the outcome of the decision, in Chapter 6.4.2. This section analyses the possibility of using Discrete-event Simulation and Queuing Theory successfully in making this decision in the Emergency Department. The analysis is conducted under each technique separately as follows.

8.2.1 Discrete-event Simulation

Even though the majority of scheduling-simulations for health care are directed at patient-scheduling, a number of simulation-models of scheduling medical staff in Emergency Departments also have been developed. Draeger (1992) simulated nurse-workload in an Emergency Room and its effect on the average number of patients, average time-in-system, average number of patients waiting, and average patient waiting-time. Comparing the current schedule's performance with two alternative staffing-schedules, they found an alternative that could reduce both the average patient time-in-system (by 23%) and the average patient waiting-time (by 57%), without increasing costs. Similarly, Evans et al. (1996) reduced a patient's length-of-stay by finding the optimal number of nurses and technicians that should be on duty during four shift-periods in an Emergency Room. Centeno et al. (2003) developed a tool that integrated DES with an integer linear program (ILP) to investigate optimal staffing-schedules for the Emergency Room, Baptist Health South Hospital, Coral Gables, Florida and showed a 28% improvement in the total person-hours per day which offered potentially significant savings in hospital labour-costs. Rosetti et al. (1999) described the application of DES to inform decisions concerning the efficient allocation and use of ED staff-resources at the University of Virginia Medical Centre in Charlottesville, USA. The study tested alternative attending-physician staffing- schedules; analyzed the corresponding impacts on patient-throughput and resource- utilization; helped identify process-inefficiencies; and evaluated the effects of staffing, layout, resource, and patient-flow changes on system-performance, without disturbing the actual system.

Swisher and Jacobson (2002) used an object-oriented visual Discrete-event Simulation to evaluate different staffing-options and facility-sizes for a two-physician family practice healthcare clinic. They describe a clinic-effectiveness measure that is used to

evaluate the overall effectiveness of a given clinic-configuration. This clinic-effectiveness measure integrates clinic profits, patient-satisfaction, and medical staff-satisfaction into a single performance-measure.

Similarly, there are many other simulation-studies for scheduling staff in healthcare. Kumar and Kapur (1989) examined ten nurse-scheduling policy alternatives, selecting and implementing the policy yielding the highest nurse-utilisation rate. Baesler et al. (2003) used a Discrete-event Simulation model to minimize the number of staff-resources required to meet patient-demand. Tan et al. (2002) presented a Discrete-event Simulation study of an urgent-care centre that simulated the current physician-schedule and a proposed schedule to test if the proposed schedule reduced the average total time patients spent at the facility. Murat et al. (2006) used simulation-modelling to understand the factors affecting A&E performance. They focused on the multi-tasking behaviour and experience-level of medical staff, both of which affect Accident and Emergency Department performance. Centeno et al. (2001) presented a simulation-study of the labour- and delivery-rooms at Jackson Memorial Hospital and identified ways to improve physician-scheduling and better staffing levels. Badri and Hollingsworth (1993) analyzed the impact of different operational-scenarios on scheduling, limited staffing, and the patient demand-patterns in an Emergency Room of the Rashid Hospital in the United Arab Emirates.

The above simulation applications and studies in ED healthcare reveal that Discrete-event Simulation can be successfully used to schedule the hospital and Emergency Department staff and improve the expected outcomes of scheduling-staff. Some studies compared the existing schedule's performance with alternative scheduling, and found an alternative that could reduce the average patient time-in-system by 57%, without increasing costs. One study showed a 28% improvement over the existing method of

staffing which offered potentially significant savings in hospital labor-costs. Most of the studies have reduced a patient's length-of-stay by finding the optimal number of staff that should be on duty during the shift-periods. Another study has measured clinic profits, patient- satisfaction, and medical staff-satisfaction with the effectiveness of the performance- measures. By carefully studying these successful applications, the researcher concludes that Discrete-event Simulation has a high capability of successful use in scheduling-staff in the Emergency Department.

8.2.2 Queuing Theory

In the literature, there is a number of Queuing Theory studies in staff-scheduling in healthcare and some of the selected applications are analysed as follows. Nosek and Wilson (2001) reviewed the use of Queuing Theory in pharmacy applications with particular attention to improving customer-satisfaction by predicting and reducing waiting-times and adjusting staffing. They further argued that Queuing Theory can be used in pharmacy to increase the satisfaction of all the relevant groups i.e. customers, employees, and management, by the assessment of a multitude of factors such as prescription fill-time, patient waiting-times, patient counselling-time, and staffing-levels. Brahim and Worthington (1991) designed an appointment-system to reduce the number of patients in the queue at any time, and reduce patient waiting-times without significantly increasing doctor idle-time. They also explored the effect of patients who do not show up for their appointments. Agnihotri and Taylor (1991) sought the optimal staffing at a hospital scheduling-department that handles phone-calls whose intensity varies throughout the day. There are known peak and non-peak periods of the day. The paper grouped the periods that received similar call-intensity and determined the necessary staffing for each such intensity, so that staffing varied dynamically with call-intensity. As a result of redistributing server-capacity over time, customer-complaints

immediately reduced without the addition of staff. Green (2006b) used the same approach, and named it Stationary Independent Period by Period (SIPP), to adjust staffing in order to reduce the percentage of patients who left without being seen in an Emergency Department. He decreased the proportion of patients who left without being seen by 22.9% despite an increase in arrival-volume of 6.3% with the same staff. These successful Queuing Theory applications in healthcare suggest that Queuing Theory is also a useful modelling technique in scheduling staff in the Emergency Department.

8.3 Allocating Resources and Equipment

The decision on Allocating Resources and Equipment is described in detail, including expected outcomes of the decision, in Chapter 6.4.3. This section attempts to identify the possibility of using Discrete-event Simulation and Queuing Theory successfully in making this decision in the Emergency Department. The analysis and discussions are conducted separately under each technique as follows.

8.3.1 Discrete-event Simulation

Even though many different kinds of resources and equipment are used in the hospital Emergency Department, most of resource-allocation simulation-studies in the literature have been done to analyse the bed-allocation in hospitals. Lowery (1992), and Lowery and Martin (1992) studied the use of simulation in a hospital's critical-care areas that are operating-rooms, recovery-units, intensive-care units, and intermediate-care units and to determine critical-care bed-requirements at individual units within a hospital. Butler et al. (1992) used a two-phase approach involving a quadratic integer programming-model and a simulation-model to evaluate bed-configurations and to determine optimal bed-allocations across a number of hospital service-areas. Butler et al. (1992) further used simulation to model a surgical intensive-care unit for various bed-levels and future

demand. Vassilacopoulos (1985) developed a simulation-model to determine the number of beds with the following constraints: high occupancy-rates, immediate patients, and low length of waiting-lists. This study showed that by using a waiting-list and smoothing the patient-demand, high occupancy rates could be achieved. Cahill and Render (1999) developed a DES of patient-flows through the ICU, telemetry, and medical-floor beds under current bed-allocation for the Cincinnati Veterans Administration Medical Centre, Arizona. Under this allocation, ICU beds are unavailable nearly one third of the time, eliminating new ICU admissions and requiring diversion of ambulance traffic. The simulation was then used to evaluate the effects of the phased construction intended to relieve the problem. Wiinamaki and Dronzek (2003) also used simulation to determine the bed-requirements for an Emergency Department expansion at the Sarasota Memorial Hospital in Sarasota, Florida. Vasilakis and El-Darzi (2001) used Discrete-event Simulation to identify the possible causes of a hospital-bed crisis that occurs each winter in United Kingdom National Health Services hospitals. Ferrin et al. (2004) used Discrete-event Simulation to determine the number of operating-rooms and number of beds required in the post-anaesthesia Care Unit at St. Vincent's Hospital in Birmingham, Alabama, USA. More bed-allocation models were simulated by Altinel and Ulas (1996) for Istanbul University School of Medicine; by Lennon (1992) for Stanford University Hospital; and by Freedman (1994) for St. Joseph Hospital and Washington Adventist Hospital in Maryland, USA.

Bed-allocation is the most successful resource-allocation application in healthcare. After reviewing these bed-allocation applications, it is clear that Discrete-event Simulation can be used as a valuable tool by ED managers to allocate their other resources and equipment in the same way to meet demand and to provide an efficient service. Moreover, Discrete-event Simulation allows hospital-administrators to experiment with

different resource-allocation rules to help them to utilise ED resources optimally, and thus improve ED performance.

8.3.2 Queuing Theory

Bruin et al. (2005) used Queuing Theory to determine the number of beds required to achieve a maximum turn-away rate of 5% at the Emergency Cardiac Department of the University Medical Centre of Amsterdam. The technique was also successfully used to identify bottlenecks and the impact of fluctuation in demand in emergency cardiac in-patient flow. Given a desired maximum turn-away rate, Bruin et al. (2007) determined the optimal number of beds in a Cardiology Department by using Queuing Theory. The Cardiology Department is modelled as a network of 3 sub-departments. The study found that too few beds downstream is the primary cause of refused admissions upstream; and that congestion effects can add 20-30% to patient length-of-stay in the Department. They characterized having a fixed target utilization-rate as unrealistic and concluded that a downstream utilization of 55% is necessary to attain a 2% turn-away rate. Kao and Tung (1981) investigated the allocation of hospital-beds amongst the inpatient-departments of a hospital. First, they established a baseline patient-capacity for each department. Then, they allocated additional beds to departments in a manner which will minimize patient-overflows from one department to another. Forecasts are used to determine both the baseline bed-allocation and the anticipated patient-demand in order to minimize overflow.

By reviewing these three bed-allocation applications, the researcher concludes that Queuing Theory also can be used as a moderately useful tool in resource- and equipment-allocation in the Emergency Department.

Table 8.1 Matrix of the Tactical Level Decisions in ED and Possible Tools

Decision	Discrete-event Simulation	Queuing Theory	System Dynamics	Lean Six sigma
Improving the ED Process	H	L	M	H
Scheduling staff	H	M	L	L
Allocating resources and equipment	H	M	L	L

H= High, M= Medium, L= Low
(Possibility of successfully using these tools for decision-making)

8.4 Summary

This chapter attempted to identify the possibility of using Discrete-event Simulation and three more techniques successfully in tactical-level decision-making in the Emergency Department. The discussion is based mainly on the comprehensive analysis of past research studies and applications in healthcare. Table 8.1 summarises the possibility of using each technique successfully in each tactical decision considered in the framework. According to this analysis, Discrete-event Simulation has become an invaluable decision-making support-tool at the tactical level of decision-making in EDs. Table 8.1 shows that there is a high possibility (H) of successfully using Discrete-event Simulation in all three tactical decisions considered in this framework. System Dynamics can be used as a moderately successful modelling-tool in making decisions to improve the ED process. But it has less suitability for use in the other two decisions. The analysis also reveals that there is a high possibility (H) of using the Lean and Six Sigma methods successfully in improving the Emergency Department process. As a mathematical modelling-tool Queuing Theory can be used as a moderately successful

(M) tool in scheduling staff and allocating resources in the Emergency Department. In the light of this analysis, the researcher concludes that Discrete-event Simulation is the most suitable modelling-tool for tactical-level decision-making in the Emergency Department. Next chapter attempts to identify the possibility of using the simulation and other systems analysis tools for the operational level decisions in the framework.

CHAPTER NINE

9. The Identification of Possible Tools for the Operational Level Decisions in ED

The previous chapter analysed the possibility of successfully using Discrete-event Simulation and three more tools at the tactical-level decision-making in ED. This chapter analyses the possibility of successfully using Discrete-event Simulation and other alternative tools in the operational-level (short-term) decisions described in the decision framework in Chapter 6. It includes three operational decisions: managing patient-flows; scheduling patients for doctors; and scheduling patients for shared-resources. The analysis is also carried out for each decision based on the published relevant applications and studies in ED and similar healthcare to the ED. In addition to Discrete-event Simulation, Queuing Theory is also discussed for each decision as an alternative tool. In a similar way to the previous two chapters, this chapter also presents a summary of the discussion with a possibility-matrix to select the successful tools and techniques in short-term decision-making in ED at the end of the chapter.

9.1 Managing Patient-flows

This decision is described in detail, including the expected outcomes, in Chapter 6.5.1. This section analyses the possibility of using the Discrete-event Simulation and other alternative techniques successfully in making this decision in the Emergency Department. The following conducts analysis and discussion under each tool and technique separately.

9.1.1 Discrete-event Simulation

A number of Discrete-event Simulation applications in managing patient-flows can be found in healthcare. Mahapatra et al. (2003) used Discrete-event Simulation to assess the effect of fast-care processing-routes for non-critical patients on waiting-times in an Emergency Department and to identify the best operating-hours for a fast-track unit. This study showed that the addition of a fast-track unit improved average waiting-times by at least 10%. Davies (2007) also used Discrete-event Simulation to compared two approaches to “See and Treat” policy in the UK Emergency Department.

Kolker (2008) used Discrete-event Simulation to establish a quantitative relationship between Emergency Department performance-characteristics, such as percentage of time spent on ambulance diversion and the number of patients in queue in the waiting-room, and the upper limits of patient length-of-stay (LOS). A simulation model of ED patient-flow has been developed that took into account a significant difference between LOS-distributions of patients discharged home and patients admitted into the hospital. Using simulation-modelling it has been identified that ED diversion could be negligible if patients discharged home stayed in ED not more than 5 hours, and patients admitted into the hospital stay in ED not more than 6 hours. It has also been determined that if the number of patients exceeds 11 in queue in the ED waiting-room then the diversion percentage rapidly increases. According to Kolker (2008) a Discrete-event Simulation could also be used to analyze other ‘what-if’ scenarios. For example, the staffing problem: what resources (the number of doctors, nurses, and technicians) would be needed to achieve and maintain the established LOS targets? What should be their shift-allocation during a day of the week, and/or for different days of the week? How to best match the staff-schedule and short-term fluctuations of the patient-flow? Guo et al. (2004) presented a DES framework for the problem based on determining prioritization

(triage) rules so that adequate patient-care is guaranteed, resources are utilized efficiently, and a service-guarantee can be ensured. They summarized their experience with a preliminary implementation for the Division of Pediatric Ophthalmology at Cincinnati Children's Hospital Medical Centre. Kirtland et al. (1995) examined eleven alternatives to improve patient-flow in an Emergency Department and identified three alternatives (using a fast-track lane in minor care; placing patients in the treatment-area instead of sending them back to the waiting-room; and the use of point-of-care lab testing) that can save on average thirty eight minutes of waiting-time per patient.

Management of patient-flow is an example of the general dynamic supply and demand problem. There are three basic components that should be accounted for in such problems: 1) the number of patients entering the system at any point of time; 2) the number of patients leaving the system after spending some time in it; 3) the capacity of the system which limits the flow of items through the system. All three components affect the flow of patients that the system can handle. A lack of the proper balance between these components results in the system's over-flow and its closure. Discrete-event Simulation provides an invaluable means for analyzing and managing the proper balance between these components in the patient-flows. One advantage of using Discrete-event Simulation is the capacity of simulation to model complex patient-flows through the Emergency Department, and then to play 'what if' scenarios by changing the patient-flow rules and policies. By considering all these facts and the applications discussed above, the researcher concludes that Discrete-event Simulation is an invaluable tool to manage patient-flows in the Emergency Department.

9.1.2 Queuing Theory

In the literature there are very limited Queuing Theory applications at the operational level of patient-flow management in the Emergency Department. Cochran (2007)

calculated the percentage of patients who leave an Emergency Department without getting help using arrival-rate, service-rate, utilization, and capacity. From this percentage, he determined the resulting revenue-loss. Siddhartan et al. (1996) analyzed the effect on patient waiting-times when primary-care patients use the Emergency Department. They proposed a priority discipline for different categories of patients and then a first-in-first-out discipline for each category. They found that the priority discipline reduces the average waiting-time for all patients; however, while the waiting-time for higher priority patients is reduced, lower priority patients endure a longer average waiting-time.

Even though Queuing Theory can analyse the waiting-time and flow of unscheduled patient-arrivals in the Emergency Department, it has limited potential to analyse the dynamic-complexity of the patient-flow in the Emergency Department compared to Discrete-event Simulation. However the researcher concludes that there is moderate possibility of using Queuing Theory successfully in managing patient-flow in the Emergency Department.

9.2 Scheduling Patients for Doctors

This decision is also described in detail, including the outcomes of the decision, in Chapter 6.5.2. This section analyses the possibility of using Discrete-event Simulation and Queuing Theory successfully in making this decision in the Emergency Department. The analysis and discussion follow under each separate technique.

9.2.1 Discrete-event Simulation

In the literature, the majority of Discrete-event Simulation studies of patient-scheduling are focused on outpatient-clinics. Quo et al. (2004) outlined a Discrete-event Simulation framework for analyzing scheduling-rules for outpatient-clinics. This framework,

termed Patient Scheduling Simulation Model (PSSM), addresses four key components of an outpatient-clinic scheduling-system: demand for appointments, supply of physician time-blocks, patient-flow, and the scheduling-algorithm. The study provides a demonstration of the framework for a paediatric ophthalmology clinic and discusses some challenges for adapting the framework to other settings. Rohleder and Klassen (2002) presented a Discrete-event Simulation study of rolling-horizon appointment-scheduling. The study considered two common management policies: Overload Rules and Rule Delay. The Overload Rules policy considers scheduling-methods such as overtime and double-booking that are used when demand is high; while the Rule Delay policy determines when to implement Overload Rules. The authors conclude that determining the "best" scheduling policy depends on the measures of performance that are deemed most important by decision-makers. Klassen and Rohleder (1996) used Discrete-event Simulation to study the best time to schedule patients with large patient service-time means and variances. They analyzed several rules and arrived at the best result that minimized the patient's waiting-time and the physician's idle-time. Additionally, they analyzed the best position for unscheduled appointment-slots for potentially urgent calls and found no conclusive scheduling-rule. Centeno, et al. (2001) described a DES study for labor- and delivery-rooms at Jackson Memorial Hospital, focusing on improving doctor- and staff-scheduling. This simulation-model also investigated possible changes in the scheduling of patients, room-scheduling, and the doctors' room-assignment. Groothuis et al. (2001) investigated two patient-scheduling procedures (the existing procedure where no patient was scheduled after 4:00pm, versus scheduling a fixed number of patients each day) for a hospital cardiac catheterization lab. Both scheduling-procedures were applied to the current configuration and three additional experimental configurations, with patient-throughput and working-day duration as the measures of performance. A Discrete-event Simulation was designed

using Medmodel and showed that the third experimental configuration under the current scheduling-procedure could, on average, accommodate two additional patients with fewer working days that exceeded eight hours.

According to the above studies and applications, Discrete-event Simulation can provide optimal patient-scheduling, balancing the trade-off between physician utilisation-rates and patient waiting-times. Discrete-event Simulation also can be used to analyze physician utilization-rates with respect to ED performance-measures by using different input-variables. After considering the above successful applications and the capabilities of the technique to achieve the desired outcomes of the decision, the researcher concludes that there is a high possibility of using Discrete-event Simulation successfully in scheduling patients for doctors in ED.

9.2.2 Queuing Theory

Fiems et al. (2007) investigated the effect of emergency requests on the waiting-times of scheduled patients with deterministic processing-times. It is a pre-emptive repeat priority queuing-system in which the emergency patients interrupt the scheduled patients and the latter's service is restarted as opposed to being resumed. This paper modelled a single-server queue and divided time into equally-long slots. Periods of emergency interruptions were considered to have no server available from the point of view of the scheduled-patients. DeLaurentis et al. (2006) pointed out that patient no-shows without cancelling appointments could lead to a waste of resources. They proposed implementing short-notice appointment-systems based on a queuing-network analysis tailored to the realities of any particular outpatient-clinic. Their approach assumed the availability of a certain number of staff who could be distributed amongst the different stations of the queuing-network in several combinations. A combination is chosen based on its resulting utilization per station and expected patient length-of-stay

in clinic. The implementations of these ideas did not improve the appointment-system, a failure which they attributed to the clinic using many visiting doctors and the patients being unable to schedule visits with their primary-care physician at short notice.

Even though there are not many Queuing Theory applications in patient-scheduling for doctors in healthcare, the above two studies reveal that Queuing Theory as a mathematical modelling-tool also has the capability to schedule patients in such complex cases. After considering the limitations of Queuing Theory as a mathematical modelling-tool, the researcher concludes that Queuing Theory can be used as a moderately-successful modelling-tool in scheduling patients for doctors in the Emergency Department.

9.3 Scheduling Patients for Shared Resources

The decision scheduling patients for shared resources is described in detail, including the expected outcomes of the decision, in Chapter 6.5.3. This sub-chapter analyses the possibility of successfully using Discrete-event Simulation and Queuing Theory in making this decision in the Emergency Department. The analysis and discussions follow under each separate technique.

9.3.1 Discrete-event Simulation

Most Discrete-event Simulation applications in patient-scheduling are focused on outpatient-scheduling. Two very successful simulation-based patient-scheduling case-studies were recently published relating to this decision. Vermeulen et al. (2008) presented a detailed Discrete-event Simulation model for scheduling patients to a hospital resource. Their approach was on an operational-level. Specifically it presented the details of the CT-scan scheduling-case at the academic hospital, the Academic Medical Centre. In current practice, adjusting the resource-calendar manually requires

constant attention and was critically dependent on the expertise of the calendar supervisor. They implemented a realistic simulation of their case-study to analyze the problem and evaluate approaches. The results of this simulation show that their approach can effectively schedule patients with different attributes and make efficient use of capacity. Ogulata et al. (2009) introduced a patient-scheduling approach for a university radiation oncology department to minimize delays in treatment due to potential prolongations in the treatment of current patients, and to maintain efficient use of the daily treatment-capacity. A simulation-analysis of the scheduling approach was also conducted to assess its efficiency under different environmental conditions and to determine appropriate scheduling-policy parameter-values. Also, the simulation-analysis of the suggested scheduling approach enabled the determination of appropriate scheduling-parameters under given circumstances. Therefore the system performed more efficiently using the appropriate scheduling-parameters and this minimized the percentage of unaccepted patients, treatment-delay, and the number of patients waiting in queue.

According to these successful scheduling-applications, it is very clear that Discrete-event Simulation can effectively schedule patients with different attributes for shared resources in the Emergency Department and make efficient use of capacity to maintain higher performance-values.

9.3.2 Queuing Theory

Queuing Theory applications relating to this decision are not common. One study has been done by Vasanaawala and Dessler (2005) to determine whether Queuing Theory would allow the prediction of the optimal number of schedule-slots to be reserved for urgent computer tomography (CT) and ultrasonography (US) at the Department of Radiology, Stanford University School of Medicine, USA. According to them, a

radiology department has some time-slots scheduled for routine radiology-analysis. Emergency requests may require re-scheduling of scheduled requests. Given a 1% or 5% probability of re-scheduling, they used Queuing Theory to determine how many scheduled slots to leave empty during routine scheduling.

Even though there is not a sufficient number of published applications in patient-scheduling for the shared resources in Emergency Department, the capability of Queuing Theory and the above similar application in healthcare reveal that Queuing Theory can be used as a moderately-successful modelling tool to support making this decision in ED.

Table 9.1 Matrix of the Operational Level Decisions in ED and Possible Tools

Decision	Discrete-event Simulation	Queuing Theory	System Dynamics
Managing patient-flows	H	M	L
Scheduling patients for physicians	H	M	L
Scheduling patients for shared resources	H	M	L

H= High, M= Medium, L= Low
(Possibility of successfully using these tools for decision-making)

9.4 Summary

This chapter attempted to identify the possibility of using Discrete-event Simulation and two more modelling techniques successfully in operational-level decisions in the Emergency Department. The analysis reveals that Discrete-event Simulation is the most suitable modelling-tool in these operational-level decisions. In the light of this analysis,

Table 9.1 summarizes the possibility of using each tool and technique in operational-level decisions considered in the framework. The table shows that there is a high possibility (H) of successfully using Discrete-event Simulation in all three decisions considered. The analysis further reveals that Queuing Theory also can be used as moderately-successful (M) mathematical modelling-tool in all three decisions. The researcher couldn't find any evidence of a System Dynamics application relating to the decisions considered at the operational-level. However, the capability of System Dynamics as a modelling-tool also reveals that there is a low possibility (L) of applying it successfully in these operational-level decisions.

CHAPTER TEN

10. Conclusion

This chapter includes three parts. The first part of the chapter concludes the thesis and the second part explains the contribution to the knowledge from the research. The final part is given the limitations and future work.

10.1 Conclusions

Over the last three decades a variety of systems-engineering tools have been used in a wide variety of applications to achieve major improvements in the quality, efficiency, safety, and customer-centred nature of processes, products, and services in a wide range of manufacturing and service-industries. The healthcare sector as a whole has been very slow to embrace them. However, a growing number of studies and applications in many areas of healthcare have been published by researchers, academics and consultants over the last two decades. Discrete-event Simulation, Queuing Theory, System Dynamics, Lean Six Sigma, and Balanced Scorecards have been adapted to applications in many areas of healthcare delivery. Among them, Discrete-event Simulation is one of the most powerful tools used to analyze the behaviour of large, complex and dynamic systems. Simulations can be used as tools that enable Emergency Departments to conduct accurate and objective predictive analyses of the effects of improvements, changes, and new designs prior to implementation. Although over the last thirty years a growing number of studies have used Discrete-event Simulation in healthcare and emergency-care, the simulation is still not widely-accepted as a viable modelling-tool in decision-making in health- and emergency-care systems.

Over the last two decades, overcrowding and long waiting-times in the Emergency Department have become a universal and growing acute problem with no easy solutions. Overcrowding is a situation in which the demand for ED services exceeds the ability of a department to provide quality care within acceptable time-frames. Chapter 5 identified numerous effects of this problem, including an increased number of medical errors, the prolonged pain and suffering of patients, more patient-deaths, decreased patient-satisfaction, increased numbers of patients leaving before treatment, increased violence, frustration of staff, ambulance-diversion, and increasing costs. Chapter 5 mainly analysed the causes of overcrowding in ED, and identified two main types of cause i.e. causes within the control of the Emergency Department and causes beyond the immediate control of the ED.

The causes beyond the control of the ED are:

- An increase in ED patient-demand;
- High patient-acuity and complexity of diseases;
- Language and cultural barriers;
- Seasonal variations (e.g. the season, holidays, the day of the week);
- Lack of funding;
- Closure or decreased hours of other hospitals;
- Reduced access to primary care;
- Lack of community care;
- Lack of preventive care.

The causes of overcrowding which can be controlled within the Emergency Department may be divided into three main categories: inefficient ED processes and policies;

deficiencies in the workforce; and inadequate facilities, resources and technology.

Under each category, the sub-causes of overcrowding are identified as follows.

The causes related to inefficient ED processes and policies are:

- Delays in diagnostics;
- Boarding patients for admission to hospital;
- Slow throughput of patients;
- Delays in ancillary services (e.g. laboratory, radiology, respiratory therapy);
- Medical record documentation requirements.

The causes related to the deficiencies in the workforce are:

- A shortage of ED nurses;
- A shortage of physicians;
- Unavailability of on-call physicians/ specialists;
- Shortages of medical and surgical subspecialists;
- Shortages of other support-staff (e.g. radiologists, technicians, housekeepers).

The causes related to the inadequate facilities, resources and technology are:

- A lack of inpatient beds;
- Unavailability of ancillary services (e.g. laboratory and radiology)
- Insufficient ED space;
- Slow or incompatible information systems.

Chapter 6 of this thesis developed an ED decisions-framework based on the causes of overcrowding found in Chapter 5. The framework included nine ED decisions covering all three categories of the causes of overcrowding and three main time-horizons i.e. long-term, medium-term and short-term. Since all the decisions in this framework are

selected based on the causes of overcrowding, the common outcome of those decisions are improved ED capacity and efficiency including reduced throughput-time and waiting-times in ED. The policy-makers and ED managers essentially need a tool or set of tools to study the outcomes of these decisions and the effects of multiple and complex changes on the entire system before the decisions are implemented. The identification of the most suitable tool or set of tools for each decision provides a better opportunity for ED managers to overcome the overcrowding problem.

Chapter 7, 8 and 9 of this thesis attempted to identify the most suitable tool or set of tools for the ED decisions in this framework in the long-term, medium-term and short-term respectively. The findings of these three chapters are summarised in Table 10.1.

Table 10.1 Matrix of Emergency Department Decisions and Possible Tools

Time	Decision	Discrete-event Simulation	Queuing Theory	System Dynamics	Lean Six Sigma	Balanced Scorecards
Long-Term	Introducing a new policy or changes	H	L	H	L	M
	Planning and recruiting workforce	H	M	L	L	L
	Planning facilities and technology	H	M	L	L	L
Medium-Term	Improving the ED process	H	L	M	H	L
	Scheduling staff	H	M	L	L	L
	Allocating resources and equipment	H	M	L	L	L
Short-Term	Managing patient-flows	H	M	L	L	L
	Scheduling patients for doctors	H	M	L	L	L
	Scheduling patients for shared resources	H	M	L	L	L

H= High, M= Medium, L= Low

(Possibility of successfully using these tools for decision-making)

Table 10.1 presents the possibility of using Discrete-event Simulation and other selected tools and techniques in making those decisions which are highly related to the overcrowding problem in EDs. The analysis reveals that DES can be successfully used as a tool that enables Emergency Departments to conduct accurate and objective predictive analyses of the effects of decisions prior to implementation at the strategic, tactical, as well as the operational level. In the light of this analysis, the researcher derived the following conclusions.

- There is a high possibility of successfully using Discrete-event Simulation in long-term, medium-term and short-term decision-making in the Emergency Department. Therefore, Discrete-event Simulation is the most suitable tool that can be used in the decision-making to overcome the overcrowding problem in the ED.
- Queuing Theory is a moderate tool for most of the decisions in the ED. As a mathematical modelling-tool it has a low possibility of successful use in two decisions, i.e. introducing new policy to the ED in the long-term and improving the ED process in the medium-term.
- System Dynamics has a high possibility of successful use in introducing new policy to the ED in the long-term. It can also be used as a moderate tool in improving the ED process in the medium-term as well. SD is not a viable tool to use in any other decisions, especially short-term ones.
- Lean Six Sigma is an industrial management technique which has a high possibility of successful use in improving the process in the Emergency

Department. But this method has a low possibility of successful use in other decisions in the Emergency Department.

- Balanced Scorecards can be used as a moderate strategic management tool in new policy implementation in the Emergency Department.

10.2 Contribution to Knowledge

The aim of this research was to develop a modelling-based framework to overcome the overcrowding problem in Emergency Departments in hospitals. In the light of the findings of this research, the following contributions are given to Knowledge.

- At the beginning of this research, a literature survey of the use of simulation in healthcare was conducted. Previously, only two comprehensive reviews of using simulation in healthcare had been conducted by Jun et al. (1999) and Fone et al. (2003). Both these reviews have covered the period until 1999 and thereafter any comprehensive review has not been done in literature. This research conducted a comprehensive review the use of simulation in healthcare from 1999 to early 2005 including the previous reviews. Filling this vacuum in literature is the first valuable contribution to knowledge from this research.
- The ED is a highly-complex system for study. In the literature there is no single comprehensive document to be familiar with ED operations and issues. This research conducted a comprehensive study to understand the ED functionality, resources, process and issues before attempting to identify the overcrowding problem. It also includes ED process-mapping, patients-arrival analysis and building a simulation-model to give an overview of the ED operations. This is the second valuable contribution to the knowledge from this research.

- Thirdly, this research conducted a comprehensive analysis of the overcrowding problem in the Emergency Department. It identified causes and consequences of the overcrowding. The causes of crowding are analysed in detail and presented in a more meaningful manner using tables and a Fishbone Diagram. It is the first comprehensive analysis of the causes of overcrowding which can be used by future researchers in this field.
- Fourthly, the research identified the hierarchal ED decisions associated with the overcrowding problem and mapped them in holistic manner for the purpose of addressing the overcrowding problem. It is also the first presentation of ED decisions in a hierarchal and holistic manner for a research purpose.
- Finally, it conducted a comprehensive analysis of the use of simulation and other system tools in healthcare, and identified the best possible tools and techniques for the given decisions in EDs to overcome the overcrowding problem.

This research is intended to provide guidance for personnel who are making decisions in Emergency Departments and Healthcare. The framework developed in this research provides a systematic approach to selecting the most appropriate tool in making given decisions in any Emergency Department. It further reveals more about different modelling techniques and their successful stories in Healthcare that can be applied in ED management. This research will not only assist Healthcare and ED decision-makers but also help professional Modellers and Systems-engineers as well as the researchers and consultants who are interested in ED management to expand their Modelling knowledge. Therefore this research contributes to knowledge in two fields of study, i.e. Healthcare and ED Management; and Modelling and Systems-engineering.

10.3 Future Work

This research focused on developing a framework which can be helpful to the ED and hospital policy-makers and administrators in choosing the appropriate systems-analysis tools and techniques in ED decision-making; and in overcoming the overcrowding problem. It didn't attempt to address the ways of using these tools and techniques to overcome the problems in the ED. The Simulation and other systems-analysis tools in the ED should no longer be just for academics and consultants. High and mid-level ED managers should actively seek out simulation as a problem-solving technique at the strategic level as well as the operational level in day-to-day decision-making. Thus it will require further research to accelerate the development, adaptation, implementation, and diffusion of Discrete-event Simulation and other systems-analysis tools in a holistic way in Emergency Department operations.

As explained in Chapter 5, the causes of Emergency Department overcrowding are of two types: causes within the Emergency Department and causes beyond the Emergency Department. This research focused on only the causes within the Emergency Department. To alleviate the overcrowding crisis in the ED, it is necessary to address all the factors, including the factors outside the ED as well. Therefore further research is required to address the whole Emergency-care system including the causes of overcrowding beyond the control of the Emergency Department.

From past experience when such new approaches are introduced into a system, they are used reluctantly and their continued use is in doubt. Therefore, it will be necessary to extend this research to embed these modelling techniques into the management system in ED for managers to use them sustainably.

References

- Abu-Taieh, E., El-Sheikh A. R. (2007). Commercial Simulation Packages: A Comparative Study. *International Journal of Simulation*, vol 8, No 2, pp. 66-76.
- Acute Health Division, (2001). Emergency demand management. Melbourne: Victorian Government Department of Human Services.
- Adriana, M. Alvarez and Martha A. Centeno (2000). Simulation-based decision support for emergency rooms systems. *International Journal of Healthcare Technology and Management*. Volume 2, Numbers 5-6, 523 - 538.
- Akkermans, H., Van Oorschoot K. (2002). Developing a Balanced Scorecard with System Dynamics. 20th International Conference of the System Dynamics Society. Palermo, Italy.
- Albin, S. L., Barrett J., Ito D. and Mueller J. (1990). A queuing network analysis of a health center. *Queuing Systems*, 7, 51-61.
- Aldarrab, A. (2006). Application of Lean Six Sigma for patients presenting with ST-elevation myocardial infarction: the Hamilton Health Sciences experience. *Healthc Q*. 2006; 9:56-61.
- Alexopoulos, C., Goldsman D., Fontanesi J., Sawyer M., Guire, M. D., Kopald D., Holcomb K. (2001). A discrete-event simulation application for clinics serving the poor. *Proceedings of the 2001 Winter Simulation Conference* B. A. Peters, J. S. Smith, D. J. Medeiros, and M. W. Rohrer, eds.
- Altinel, I. K. and Ulas E. (1996). Simulation modeling for emergency bed requirement planning. *Annals of Opns Res* 67: 183-210.
- Altobelli, F., Ramzy A. and Schaefer R. (1989). Emergency Medical System Networked Simulation. *Proceedings of the 13th Annual Symposium on Computer Applications in Medical Care*, Washington, DC, USA, pp. 99-100.
- Alvarez, A. M., Centeno M. A. (1999). Enhancing simulation models for emergency rooms using VBA. *Proceedings of the 1999 Winter Simulation Conference*.
- American Academy of Pediatrics, (2004). Overcrowding Crisis in Our Nation's Emergency Departments: Is Our Safety Net Unraveling?, *Pediatrics*, Vol. 114 No. 3 Sep. 2004.
- American College of Emergency Physicians, (2002). Crowding Resources Task Force. Responding to Emergency Department Crowding: A Guidebook for Chapters. Dallas, TX: American College of Emergency Physicians. Available at: www.acep.org/library/pdf/edCrowdingReport.pdf.
- American College of Emergency Physicians, (2006). Crowding. *Ann Emerg Med*. 2006; 47:585.

- American College of Emergency Physicians, (2007). Emergency Department Planning and Resource Guidelines <http://www.acep.org/workarea/downloadasset.aspx?id=33620>.
- American College of Emergency Physicians, (2008). Crowding Resources Task Force. Responding to American Hospital Association. Taking the Pulse: The State of America's Hospitals. Available at: <http://www.aha.org/aha/content/2005/pdf/TakingthePulse.pdf> Accessed March 2008.
- American Hospital Association, (2001). AHA Special Workforce Survey Report June 2001. <http://www.aha.org/aha/research-and-trends/health-and-hospital-trends/2003-or-earlier.html>.
- Amladi, P. (1984). Outpatient health care facility planning and sizing via computer simulation. In: Sheppard S, Pooch UW and Pegden CD (eds). Proceedings of the 1984 Winter Simulation Conference. Institute of Electrical and Electronics Engineers, Dallas, Texas, USA, 28-30 November, pp 705-711.
- Andersson, G. and Karlberg I. (2001). Lack of integration, and seasonal variations in demand explained performance problems and waiting times for patients at emergency departments: a three year evaluation of the shift of responsibility between primary and secondary care by closure of two acute hospitals. *Health Policy* 55:187-207.
- Andrulis, D. P., A. Kellermann, E. A. Hintz, B. B. Hackman, and V. B. Weslowski. (1991). Emergency departments and crowding in United States teaching hospitals. *Annals of Emergency Medicine* 20:980-6.
- Arizona College of Emergency Physicians, (2000). Emergency department crowding & ambulance diversion. Arizona: Arizona College of Emergency Physicians.
- Ashby, M., Miller M., Ferrin D., Flynn T. (2007). Simulating the Patient Move: Transitioning to a Replacement Hospital. Proceedings of the 2007 Winter Simulation Conference S. G. Henderson, B. Biller, M.-H. Hsieh, J. Shortle, J. D. Tew, and R. R. Barton, eds.
- Ashton, R., L Hague, M. Brandreth, D. Worthington, S. Cropper (2005). A simulation-based study of a NHS Walk-in Centre. *Jnl Ops Res Soc.*, 56, 153-161.
- Asplin, B. R., Knopp R. K. (2001). A room with a view on-call specialist panels and other health policy challenges in the emergency department. *Ann Emerg Med.* 2001; 37:500-503.
- Asplin, B. R., Magid D. J., Rhodes K. V., Solberg L. I., Lurie N., Camargo C.A. (2003). A conceptual model of emergency department crowding. *Annals of Emergency Medicine*, 42(2), 173-180.
- Asplin, B. R., Rhodes, K. V., Crain, L., Camargo, C. A. (2002). Measuring emergency department crowding and hospital capacity. *Academic Emergency Medicine*, 9(5), 366-367.

- Audit Commission, (2001). *By Accident or Design: Improving A&E Services in England and Wales*. London: HMSO.
- Audit Commission, (2003). *Acute hospital portfolio: Bed management*. [Online]. at www.healthcarecommission.org.uk/assetRoot/04/00/02/38/040002_38.pdf.
- Austin, C. (2009). *What is Pragmatism? History of Pragmatism, Pragmatic Philosophy, Philosophers*. About.com. Accessed on 07.12.2009.
- Australasian College of Emergency Medicine, (2009). *ACEM Policy on Standard Terminology*. http://www.acem.org.au/media/policies_and_guidelines/P02_-_Standard_Terminology_16.04.09.pdf.
- Australia Health Workforce Advisory Committee, (2004). *Nurse Workforce Planning in Australia*, AHWAC, Canberra.
- Baessler, F. Felipe, Jahnsen E. Hector and Da Costa Mahal. (2003). *The use of simulation and design of experiments for estimating maximum capacity in an emergency room*. In *Proceedings of the 2003 Winter Simulation Conference*, S. Chick, P. J. Sanchez, D. Ferrin, and D. J. Morrice (eds), 1903-1906.
- Bagust, A., Place M., & Posnett J. W. (1999). *Dynamics of bed use in accommodating emergency admissions: Stochastic simulation model*. *British Medical Journal*, 319, 155-158.
- Balci, O. (1998). *Verification, validation, and Accreditation*. In *Proceeding of the 1998 Winter Simulation Conference*, ed. J. S. Carson, M. S. Manivannan, D. J. Medeiros, and E. F. Watson. 41-48. Washington DC, USA.
- Baldwin, L. P., T. Eldabi, R. J. Paul (2004). *Simulation in healthcare management: a soft approach (MAPIU)*. *Simulation Modelling Practice and Theory*, 12 541-557.
- Banks, J. (2000). *Introduction to simulation*. In *Proceedings of the 2000 Winter Simulation Conference*, ed. P. A. Fishwick, K. Kang, J. A. Joines, and R. R. Barton. 9-16. Orlando, FL, USA.
- Banks, J. and V. Norman (1995). *Justifying simulation in today's manufacturing environment*, IIE Solutions.
- Banks, J., Carson J. S. (1984). *Discrete-event system simulation*. Prentice-Hall Inc., Englewood cliffs, New Jersey.
- Banks, J., Carson J. S. and Nelson B. L. (1996), *Discrete Event System Simulation*, 2nd edn, Prentice Hall.
- Banks, J., ed. (1998). *Handbook of Simulation: Principles, Methodology, Advances, Applications, and Practice*, John Wiley & Sons.
- Banks, J., J. S. Carson II, B. L. Nelson, and D. M. Nicol (2000). *Discrete event system simulation*, 3rd Ed., Upper Saddle River, New Jersey: Prentice-Hall.

- Bardi, M. A. and Hollingsworth J. (1993). A Simulation Model for Scheduling in the Emergency Room, *International Journal of Operation & Production Management*, vol. 13, no. 3, pp. 13-24.
- Bayley, M., Schwartz, J. Shofer, F., Weiner, M., Sites, F., Traber, K. and Hollander, J. (2002). The financial burden of ED congestion and hospital overcrowding for chest pain patients awaiting admission. *Academic Emergency Medicine* 9:367-a.
- Benbasat, I, Goldstein D. K., Mead M. (1987) Case Research Strategy in Studies of Information Systems, *MIS Quarterly*, vol. 11, pp. 369-386.
- Benjamin, P. D. D., R Mayer, and T O'Brien. (2000). A model-based approach for component simulation development. In JA Joines, RR Barton, K Kang, and PA Fishwick, editors, *Proceedings of the 2000 Winter Simulation Conference*, pages 1831–1839, December 2000.
- Bergman, D. (1990). Computerized Simulation Model of a Hospital in Disaster Situation, Ph.D. Thesis, Technion – Israel Institute of Technology, December 1990.
- Bevan, H., Westwood N., Crowe R., O'Conno M. (2005). *Lean Six Sigma: some basic concepts*, Institute for Innovation and Improvement. www.institute.nhs.uk.
- Birkland, T. A. (2001). *An introduction to the policy process: Theories, concepts, and models of public policy making*. Armonk, NY: M.E. Sharpe.
- Blake, J. T. and Carter M. W. (1996). An Analysis of Emergency Room Wait Time Issues Via Computer Simulation. *INFOR*, Vol. 34, pp. 263-272.
- Blasak, E. Ruby, Starks W. Darrell, Arnel S. Wendy and Hayduk C. Mary, (2003). The use of simulation to evaluate hospital operations between the emergency department and a medical telemetry unit. In *Proceedings of the 2003 Winter Simulation Conference*, S. Chick, P. J. Sanchez, D. Ferrin, and D. J. Morrice (eds), 1887-1893.
- Boxerman, S. (1996). *Simulation Modeling: A Powerful Tool for Process Improvement, Best Practices and Benchmarking in Healthcare*, 109-117, Vol.1, No.3.
- Bradley, V. M. (2005). Placing Emergency Department Crowding on the Decision Agenda *Nursing Economics*, Jan-Feb 2005, Vol. 23, No. 1.
- Brahimi, M. and Worthington, D. J. (1991) Queueing models for out-patient appointment systems – a case study. *The Journal of the Operational Research Society*, 42, 733-746.
- Brailsford, S. C. (2008). System dynamics: what's in it for healthcare simulation modelers. *Proceedings of the 2008 Winter Simulation Conference*. S. J. Mason, R. R. Hill, L. Mönch, O. Rose, T. Jefferson, J. W. Fowler eds.
- Brailsford, S. C., L. Churilov and S. K Liew. (2003). Treating ailing emergency departments with simulation: An integrated perspective. *Development* 4,: 5.

- Brassard, M., Ritter D. (2002). *Sailing through Six Sigma*. Marietta, GA: Brassard & Ritter, LLC; 2002.
- Brewer, S. (2002). Study: clogged trauma care leads to deaths. *Houston Chronicle*. 3:A27.
- Brewster, L. R., Rudell L. S, Lesser C. S. (2001). Emergency room diversions: a symptom of hospitals under stress. *Issue Brief Cent Stud Health Syst Change*. 38:1-4.
- British Association for Emergency Medicine, (2005). *Way Ahead 2005*. London: British association for Emergency Medicine, 2005.
- British Association for Emergency Medicine, (2007). *The Reorganisation of Emergency Services (England)* www.collemergencymed.ac.uk/asp/document.asp?ID=3917.
- British Medical Association, (2005). Survey of A&E waiting times. http://www.bma.org.uk/images/AEwaitingtimes_tcm28-20446.pdf.
- Bronson, R., Naadimuthu G. (1997). *Operations Research*, 2nd edition, MacGraw-Hill, New York Londo.
- Broyles, J. R. and Cochran, J. K. (2007). Estimating business loss to a hospital emergency department from patient renegeing by queuing-based regression, in *Proceedings of the 2007 Industial Engineering Research Conference*, 613-618.
- Bruin, A. M., Koole G. M. and Visser M. C. (2005). Bottleneck analysis of emergency cardiac in-patient flow in a university setting: an application of queueing theory. *Clinical and Investigative Medicine*, 28, 316-317.
- Bruin, A. M., Rossum A. C., Visser M. C. and Koole G. M. (2007). Modeling the emergency cardiac in-patient flow: an application of queueing theory. *Health Care Management Science*, 10, 125-137.
- Burt, C. W., McCaig L. F. (2006). *Staffing, Capacity, and Ambulance Diversion in Emergency Departments: United States, 2003-04*. Advance data from vital and health statistics; no. 376. Hyattsville, MD: National Center for Health Statistics. 2006.
- Burt, C. W., McCaig L. F., Valverde R. H. (2002). Analysis of ambulance transports and diversions among US emergency departments. *Ann Emerg Med*. 2006; 47(4):317-326.
- Burt, C.W, L. F. McCaig, and E. A. Rechsteiner (2004). *Ambulatory Medical Care Utilization Estimates for 2004*. <http://www.cdc.gov/nchs/products/pubs/pubd/hestats/estimates2004/estimates04.htm>.
- Butler, T. W., Karwan K. R. and Sweigart J. R. (1992). Multi-level strategic evaluation of hospital plans and decisions. *J Opl Res Soc'* 43: 665-675.
- Cahill, W., Render M. (1999). Dynamic simulation modelling of ICU bed availability. *Proceedings of the 1999 Winter Simulation Conference*.

- Caldwell, C, Brexler J, Gillem T. (2005). *Lean Six Sigma for healthcare*. New York: Productivity Press; 2005.
- California Medical Association, (2001). *California's Emergency Services: A System in Crisis*. <http://www.cmanet.org/upload/ERWhitePaper.pdf>.
- California Workforce Initiative. (2000). *Minimum nurse staffing ratios in California acute care hospitals*. San Francisco: California Workforce Initiative.
- Canadian Association of Emergency Physicians, and the National Emergency Nurses Affiliation (2003). *Joint position statement: Access to acute care in the setting of emergency department overcrowding*. *Canadian Journal of Emergency Medicine*, 5(2), 81-86.
- Canadian Association of Emergency Physicians, Working Group (2002). *The future of emergency medicine in Canada: Submission from CAEP to Romanow Commission, Part 2*. *The Journal of the Canadian Association of Emergency Physicians*, 4(6), 431-439.
- Carson II, J. S. (2005). *Introduction to modelling and simulation*. Proceedings of the 2005 Winter Simulation Conference, M. E. Kuhl, N. M. Steiger, F. B. Armstrong, and J. A. Joines, eds.
- Carson, J. S. (1993). *Modeling and simulation world views*, in Proceedings of the 1993 Winter Simulation Conference, ed. G.W. Evans, M. Mollaghasemi, E.C. Russell, and W.E. Biles, Institute of Electrical and Electronics Engineers, pp. 18-23. Piscataway, NJ.
- Cavaye, A. L. M. (1996). *Case-study Research: A Multi-faceted Research Approach for IS*. *Information Systems Journal*, 6, 227-242.
- Centeno, A. Martha, Giachetti Ronald, Linn Richard, and Ismail M. Abdullah, (2003). *A simulation-ILP based tool for scheduling ER staff*. In Proceedings of the 2003 Winter Simulation Conference, S. Chick, P. J. Sanchez, D. Ferrin, and D. J. Morrice (eds), 1930-1938.
- Centeno, M. A., Albacete C., Terzano D. O., Carrillo M. and Ogazon T. (2000). *A simulation study of the radiology department at JMH*, Proceedings of the 2000 Winter Simulation Conference (J.A. Joines, R.R. Barton, K. Kang, P.A. Fishwick, Editors), 1978- 1984.
- Centeno, M. A., Lee, M. A., Lopez, E., Fernandez, H. R., Carrillo, M. and Ogazon, T. (2001). *A simulation study of the Labor and Delivery Rooms at JMH*. In: Proceedings of the Winter Simulation Conference. pp 1392-1400 vol.2.
- Chow, C.W., D. Ganulin, O. Teknika, K. Haddad, and J. Williamson (1998). "The Balanced Scorecard: a potent tool for Energizing and Focusing Healthcare Organization Management." *Journal of Healthcare Management* 43(3): 263-280.
- Christine, D., Fatah C. (2007). *Modeling and Improving Emergency Department Systems using Discrete Event Simulation*. The Society for Modeling and Simulation International, SIMULATION, Vol. 83, Issue 4, April 2007 311-320.

- Chung, C. H., Ng, C. P. and Lai, K. K. (2000). 'Delays by patients, emergency physicians, and surgeons in the management of acute appendicitis: retrospective study', *Hong Kong Medical Journal* 6:254-259.
- Clark, K., Normile L. B. (2002). Delays in implementing admission orders for critical care patients associated with length of stay in emergency departments in six mid-Atlantic states. *Journal of Emergency Nursing*, 28(6), 489-495.
- Cochran, J. K. and Broyles, J.R. (2007). Estimating business loss to a hospital emergency department from patient renegeing by queuing-based regression, in *Proceedings of the 2007 Industrial Engineering Research Conference*, 613-618.
- Commission for Healthcare Audit and Inspection, (2005). Acute hospital portfolio review: Accident and emergency, http://www.cqc.org.uk/_db/_documents/04019296.pdf, accessed on 11,09,2009.
- Commission for Healthcare Audit and Inspection, (2008). Not just a matter of time: A review of urgent and emergency care services in England http://www.cqc.org.uk/_db/_documents.
- Committee on the Future of Emergency Care in the United States Health System, (2007). Hospital-based emergency care: At the breaking point. Washington DC: National Academies Press.
- Connelly, L. G. and Bair A. E. (2004). Discrete event simulation of emergency department activity: a platform for system-level operations research. *Acad Emergency Med*, 11: 1177-1184.
- Cooke, M. W., Wilson S., Halsall J., et al., (2004). Total time in English accident and emergency departments is related to bed occupancy. *Emerg Med J*. 2004;21:575-576.
- Couchman, A., Jones D. I., Griffiths K. D. (2002). Predicting the future performance of a clinical biochemistry laboratory by computer simulation. *Simulation Modelling Practice and Theory* 10, 473-495.
- Cowan, R. M., Trzeciak S. (2005). Clinical review: emergency department overcrowding and the potential impact on the critically ill. *Crit Care*. 9(3):291-295.
- Crowding Resources Task Force, (2002). Responding to emergency department crowding: A guidebook for chapters. Dallas, TX: American College of Emergency Physicians.
- Curry, G., Hall, C. A., Schorn, R. (2003). Emergency department overcrowding: Impact of hospital occupancy on length of stay in emergency. Paper presented at the Canadian Association of Emergency Physicians 2003 Scientific Abstracts.
- Dangerfield, B. C. (1999). System dynamics applications to European health care issues. *Journal of the Operational Research Society*, 50:345-53.

- Darke, P., Shanks G. and Broadbent M. (1998). Successfully Completing Case-study Research: Combining Rigor, Relevance and Pragmatism. *Information Systems Journal*, 8, 273-289.
- Davies , R. (2007). "See and Treat" or "See" and "Treat" in an Emergency Department. In *Proceedings of the 2007 Winter Simulation Conference*, ed. S. G. Henderson, B. Biller, M.-H. Hsieh, J. Shortle, J. D. Tew, and R. R. Barton. 1519-1522.
- Davies, R. and Davies H. T. O. (1994). Modelling patient flows and resource provision in health systems, *Omega International Journal of Management Science* 22(2) 123–131.
- De Koning, H., Verver J. P., van den Heuvel J., et al. (2006). Lean Six Sigma for healthcare. *J Healthc Qual* 28:4 –11.
- DeLaurentis, P., Kopach R., Rardin R., Lawley M., Muthuraman K., Wan H., Ozsen L. and Intrevado P. (2006). Open access appointment scheduling – an experience at a community clinic, in *IIE Annual Conference and Exposition*.
- Denzin, N. K. & Lincoln, Y. S. (1998). *Strategies of Qualitative Inquiry*. Thousand Oaks, CA: Sage. ISBN: 0-7619-1435-8.
- Department of Health, (2004). *Improving Emergency Care in England*, http://www.nao.org.uk/publications/0304/improving_emergency_care_in_en.aspx.
- Department of Health, (2000). *The NHS plan*, available via <<http://www.dh.gov.uk/Home/fs/en> [accessed March, 2005].
- Department of Health, (2002). *Improvement, Expansion and Reform: The next three years. Priorities and Planning Framework, 2003-2006*, available via <<http://www.dh.gov.uk/Home/fs/en>> [accessed July, 2006].
- Department of Health, (1999). *Agenda for change: modernising the NHS pay system*. London: Department of Health.
- Department of Health, (2000). *Comprehensive critical care. A review of adult critical care services*. London: Department of Health.
- Derlet, R. W., & Richards J. R. (2000). Overcrowding in the nation's emergency departments: Complex causes and disturbing effects. *Annals of Emergency Medicine*, 35(1), 63-68.
- Derlet, R. W., Nishio D., Cole L. M. and Silva J.Jr. (1992). Triage of patients out of the emergency department: three-year experience, *American Journal of Emergency Medicine* 10:195-199.
- Derlet, R. W., Richards J. R. (2002). Emergency department overcrowding in Florida, New York, and Texas. *South Med J*;95:846–9.
- Derlet, R., Richards J. and Kravitz R. (2000). ED overcrowding: definition and magnitude, *Academic Emergency Medicine* 7:544.

- Derlet, R., Richards J., & Kravitz R. (2001). Frequent overcrowding in U.S. emergency departments. *Academic Emergency Medicine*, 8(2), 151-155.
- Draeger, M. A. (1992), An emergency department simulation model used to evaluate alternative nurse staffing and patient population scenarios. Proceedings of the 1992 Winter Simulation Conference (J.J. Swain, D. Goldsman, R.C. Grain, J.R. Wilson, Editors). 1057-1064.
- Dunn, R. (2003). Reduced access block causes shorter emergency department waiting times: An historical control observational study. *Emerg Med (Fremantle)*. 2003;15(3),232-238.
- Edwards, R., J. Clague, J. Barlow, M. Clarke, P. Reed, and R. Rada, (1994). Operations research survey and computer simulation of waiting times in two medical outpatient clinic structures. *Health Care Analysis*, 2:164-169.
- Eldabi, T., Paul R. J., Taylor S. J. E. (1999). Computer Simulation in Healthcare Decision Making. *Computers & Industrial Engineering* 37, 235-238.
- Eldabi, T., Paul R. J. and Young T. (2007). Simulation modelling in healthcare: reviewing legacies and investigating futures. *Journal of the Operational Research Society* 58:262-270.
- Eldabi, T., Young T. (2007b). Towards a Framework for Healthcare Simulation. Proceedings of the 2007 Winter Simulation Conference.
- Eleazer, M., Gronhaug R., Haugene K. (2003). Proposals to reduce over-crowding, lengthy stays and improve patient care: Study of the geriatric department in Norway's largest hospital. Proceedings of the 2003 Winter Simulation Conference.
- El-Haik, B., Al-Aomar R. (2006). Simulation-based Lean Six-Sigma and Design for Six-Sigma. John Wiley and Sons, Inc.
- Emergency Medicine Practice Subcommittee on Crowding, (2004). American College of Emergency Physicians. <http://www.acep.org/WorkArea/DownloadAsset.aspx?id=8872>.
- Estey, A., Ness K., Saunders D., Alibhai A. and Bear R. A. (2003). Understanding the causes of overcrowding in emergency departments in the Capital Health Region in Alberta focus group study, *Canadian Journal of Emergency Medicine* 5:87-94.
- Evans, G. W., Gor T. B., and Unger E. (1996). A simulation model for evaluating personnel schedules in a hospital emergency department, Proceedings of the 1996 Winter Simulation Conference. (J.M. Charnes, D.M. Morrice, D.T. Brunner, J.J. Swain, Editors), 1205- 1209.
- Fairbanks, C. B. (2007). Using Six Sigma and Lean methodologies to improve OR throughput. *AORN J* 2007; 86:73- 82.

- Fatovich, D. M., & Hirsch, R.L. (2003). Entry overload, emergency department overcrowding, and ambulance bypass. *Emergency Medicine Journal*, 20(5), 406-409.
- Fatovich, D. M. (2002). Recent developments: emergency medicine. *BMJ* 2002; 324:958-62.
- Ferrin, D. M. Miller M. J. Wininger S. and Neuendorf M. S. (2004). Analyzing incentives and scheduling in a major metropolitan hospital operating room through simulation. *Proceedings of the 2004 Winter Simulation Conference* (R.G. Ingalls, M.D. Rossetti, J.S. Smith, B.A. Peters, Editors), 1975-1980.
- Ferrin, D., M. Miller, and G. Giron. (2000). Electronic Workflow For Transaction-Based Work Cells In A Financial Services Firm. In *Proceedings of the 2000 Winter Simulation Conference*, ed J.A. Joines, R.R. Barton, K. Kang, P.A. Fishwick.
- Ferrin, M. D., McBroom D. L., Miller M. J. (2007). Maximizing hospital financial impact and emergency department throughput with simulation. *Proceedings of the 2007 Winter Simulation Conference*. S. G. Henderson, B. Biller, M.-H. Hsieh, J. Shortle, J. D. Tew, and R. R. Barton, eds.
- Fiems, D., Koole G. and Nain P. (2007). Waiting times of scheduled patients in the presence of emergency requests. <http://www.math.vu.nl/~koole/articles/report05a/art.pdf>, accessed August 6, 2007.
- Fitzpatrick, M. A. (2002). Let's bring balance to health care. *Nursing Management* 33 (3): 35-37.
- Fletcher, A., Cummings J., Cooke M. and Black S. (2004). *Emergency Care Waits: survey Using a National Representative Sample*. London: Department of Health.
- Fone, D., Hollinghurst S, Temple M, Round A, Lester N, Weightman A, Roberts R, Coyle E, Bevan G, Palmer S (2003). Systematic Review of the use and value of computer simulation modelling in population health and health care delivery. *Journal of Public Health Medicine*. 25 (4), 325-35.
- Forgione, D. (1998). Health Care Financial and Quality Measures: International Call for a "Balanced Scorecard" Approach. *Journal of Health Care Finance* 24, no. 1: 55-58.
- Forrester, J. W. (1961). *Industrial dynamics*. Cambridge, MA: MIT Press.
- Forrester, J. W. (1969). *Urban dynamics*. Cambridge, MA.: MIT Press, 1969.
- Forrester, J. W. (1991). *System dynamics and the lessons of 35 years: MIT System Dynamics in Education Project*; D-4224-4; April 29.
- Forster, A. J., Stiehl, I., Wells, G., Lee, A.J., van Walraven, C. (2003). The effect of hospital occupancy on emergency department length of stay and patient disposition. *Academic Emergency Medicine*, 10(2), 127-133.

- Franaszek, J. B., Aspli B. R., Brunne B., Epstein S.K., Fields W.W., Hill M. B., Kaplan J.A., Krakover B., Mitchiner J. C., Nedza S. M., Schneider S. M., Taylor T.B. and King K. (2002). Responding to emergency department crowding: A guidebook for chapters.
- Freedman, R. W. (1994). Reduction of average length of stay in the emergency room using discrete simulation. In: Anderson JG and Katzper M (eds). Proceedings of Simulation in the Health Sciences. Society for Computer Simulation, Tempe, Arizona, U SA, 24-26 January, pp 6-8.
- Garcia, M. L., Centeno M. A., Rivera C., and De Cario N. (1995). Reducing time in an emergency room via a fast-track. Proceedings of the 1995 Winter Simulation Conference (C. Alexopoulos, K. Kang, W.R. Lilegdon, D. Goldsman, Editors) 1048-1053.
- General Accounting Office, (2003). Hospital emergency departments: Crowded conditions vary among hospitals and communities. Retrieved September 20, 2003, from <http://www.gao.gov>.
- George, M. L. (2003). Lean Six Sigma for service: how to use Lean speed and Six Sigma quality to improve services and transactions. New York: McGraw-Hill.
- George, M. L., Rowlands D. T, Price M., Maxey J. (2005). The Lean Six Sigma pocket tool book. New York: McGraw-Hill.
- Gilbert, N., (1993). Researching Social Life: SAGE Publications Ltd London.
- Gonzalez, C. J., Gonzalez M. and Rios N. M. (1997). Improving the Quality of Service in an Emergency Room Using Simulation-Animation and Total Quality Management, Computer and Industrial Engineering. Vol. 33, no. 1-2, pp. 87-100.
- Gordon, B. D., and Asplin B. R. (2004). Using Online Analytical Processing to Manage Emergency Department Operations, ACAD EMERG MED, November 2004, Vol. 11, No. 11.
- Gordon, J. A., Billings J., Asplin B. R., Rhodes K.V. (2001). Safety net research in emergency medicine: proceedings of the Academic Emergency Medicine Consensus Conference on 'The Unraveling Safety Net. Acad Emerg Med 2001, 8:1024-1029.
- Gorunescu, F., McClean S.I, Millard P. H. (2002). Using a queuing model to help plan bed allocation in a department of geriatric medicine. Health Care Management Science 5(4):307.312.
- Graff, L. (1999). Overcrowding in the ED: an international symptom of health care system failure, American Journal of Emergency Medicine 17:208-209.
- Green, L. (2006a). Queueing analysis in healthcare, in Patient Flow: Reducing Delay in Healthcare Delivery, Hall, R.W., ed., Springer, New York, 281-308.

- Green, L. V., Soares J., Giglio J.F., Green R. A. (2006). Using queuing theory to increase the effectiveness of emergency department provider staffing. *Academic Emergency Medicine* 13(1):61.68.
- Greene J. (2007). Emergency Department Flow and the Boarded Patient: How to Get Admitted Patients Upstairs. *Annals of Emergency Medicine*, 49 (1): 68-70.
- Griffiths, J. D., N. Price-Lloyd, M. Smithies, J. E. Williams (2005). Modelling the requirement for supplementary nurses in an intensive care unit. *Jnl Ops Res Soc.*, 56, 126-133.
- Groothuis, S., Goldschmidt H. M. J., Drupsteen E. J., de Vries J. C. M, Hasman A. and van Merode G. G. (2002). Application of computer simulation analysis to assess the effects of relocating a hospital phlebotomy department. *Annals of Clinical Biochemistry*, 39:261- 272.
- Groothuis, S., van Merode G. G., Hasman A. (2001). Simulation as decision tool for capacity planning. *Computer Methods and Programs in Biomedicine* 66, 139-151.
- Gunal, M. M. and M. Pidd (2005). Performance assessment of hospitals by using simulation. EURO Working Group on OR Applied to Health Services 31st Annual Meeting, 31 Jul-5 Aug 2005, Southampton, U.K.
- Gunal, M. M. and M. Pidd (2006). Understanding Accident and Emergency Department Performance Using Simulation. *Proceedings of the 2006 Winter Simulation Conference*. L. F. Perrone, F. P. Wieland, J. Liu, B. G. Lawson, D. M. Nicol, and R. M. Fujimoto, eds.
- Gunal, M. M. and Pidd M. (2007). Interconnected DES Models of Emergency, Outpatient, and Inpatient Departments of a Hospital, [ed.] J Tew, et al. *Proceedings of the 2007 Winter Simulation Conference*, pp. 1461-1466, Washington, DC.
- Guo, M., Wagner M., West C. (2004). Outpatient clinic scheduling as a simulation approach. *Proceedings of the 2004 Winter Simulation Conference*.
- Gupta, I., Zoreda J., and Kramer N. (1971). Hospital manpower planning by use of queuing theory. *Health Services Research*, 6, 76-82.
- Hagg, H., Scachitt S., Mapa L., Brandford L., Vanni C., Cox C. (2007). Application of Lean Six Sigma techniques to optimize hospital laboratory Emergency Department Turnaround time across a multi-hospital system, American Society for Engineering Education Illinois-Indiana Section Conference, *Proceedings of the Spring 2007*.
- Hall, T., Mejia A. (eds) (1998). *Health Manpower Planning: Principles, Methods, Issues*. World Health Organisation, Geneva, Switzerland.
- Harper, P. R., H. M. Gamlin (2003). Reduced outpatient waiting times with improved appointment scheduling: a simulation modeling approach. *OR Spectrum*, 25: 207-222.

- Harper, P. R, A. K. Shahani (2002). Modelling for the planning and management of bed capacities in hospitals. *Jnl Ops Res.Soc.* 53, 11-18.
- Harper, P. R. and Pitt M. A., (2004). On the Challenges of Healthcare Modelling and a Proposed Project Life Cycle for Successful Implementation. *The Journal of the Operational Research Society*, Vol. 55, No. 6 pp. 657- 661.
- Harry, M. J., Schroeder R. (1999). *Six sigma: the breakthrough management strategy revolutionizing the world's top corporations.* New York: Doubleday.
- Hengst, M. D., Hlupic, V., and Currie, W. L. (2004). The increasing need for integrating simulation and collaboration to support change management programs, in *Proceedings of HICSS 2004.*
- Hirsch, Gary, Jack Homer, Geoff McDonnell, and Bobby Milstein (2005). Achieving health Care reform in the United States: Toward a whole system understanding. In the *Proceedings of 2005 International Conference of the System Dynamics Society.*
- Hlupic, V. (2000). Simulation Software: An Operational Research Society Survey of Academic and Industrial Users. *Proceedings of the Winter Simulation Conference 2000, Orlando, USA, December 2000, (Eds.) Joines J.A., Barton R.R., Kang K. and Fishwick P., 1676-1683.*
- Homer, J. B, Hirsch G. B. (2006). System dynamics modeling for public health: background and opportunities. *American Journal of Public Health* 2006; 96(3):452-458.
- Homer, J. B, Oliva R. (2001). Maps and models in system dynamics: a response to Coyle. *System Dynamics Review* 2001; 17 (4):347-355 <http://www.collemergencymed.ac.uk/cem>.
- Huang, X. M. (1995). A planning model for requirement of emergency beds. *IMA Journal of Mathematics Applied in Medicine & Biology* 12(3.4):345.353.
- Hurst, K. (1993). *Nurse Workforce Planning.* Longman Publishing, UK. Mooney H (2007) SHAs told they must plug shortfall of 14,000 nurses. *Health Service Journal*, 4 January.
- Hussey, J., Hussey R. (1997), *Business Research: A Practical Guide for Undergraduate and Postgraduate Students,* Macmillan Press, London.
- Ishimoto, K., Ishimitsu T., Koshiro A., and Hirose S. (1990). Computer simulation of optimum personnel assignment in hospital pharmacy using a work-sampling method. *Medical Informatics*, 15(4): 343-354.
- Iskander, W. H. and Carter (1991). A simulation model for a same day care facility at a university hospital. In: Nelson BL, Kelton WD and Clark GM (eds). *Proceedings of the 1991 Winter Simulation Conference.* Institute of Electrical and Electronics Engineers, Phoenix, Arizona, USA, 8- 11 Decem-ber, pp 846-853.

- Jacobson, S., Hall S. and Swisher J. (2006). Discrete-event simulation of health care systems, in *Patient Flow: Reducing Delay in Healthcare Delivery*, Hall, R.W. ed., Springer, New York, 211-252.
- Johnson, L. A., Taylor T.B., Lev R. (2001). The emergency department on-call backup crisis: finding remedies for a serious public health problem. *Ann Emerg Med.* 2001; 37:495-499.
- Johnson, W. C. (1998). Birth of a new maternity process. *Proceedings of the 1998 Winter Simulation Conference* (J.D. Medeiros, E.F. Watson, J.S. Carson, M.S. Manivannan, Editors), 1429-1432.
- Joint Commission on Accreditation of Healthcare Organizations, (2002). Sentinel event alert. Retrieved October 31, 2005, from <http://www.jcaho.org>.
- Joint Commission on Accreditation of Healthcare Organizations, (2003a). Sentinel event statistics: from <http://www.jcaho.org/accredited+organizations/ambulatory+care/setinel+event+statistics.htm>.
- Joint Commission on Accreditation of Healthcare Organizations, (2003b). Emergency department overcrowding standards. from http://www.jcaho.org/accredited+organizations/hospitals/standards/draft+standards/er_fr_std.pdf
- Jun, J. B., Jacobson S. H. and Swisher J. R. (1999). Application of Discrete-Event Simulation in Health Care Clinics: A Survey, *Journal of the Operational Research Society*, Vol. 50, No. 2, pp. 109-123.
- Kao, E. P. C. and Tung G. G. (1981). Bed allocation in a public health care delivery system. *Management Science*, 27, 507-520.
- Kaplan, R. S. and D. P. Norton (1992). The Balanced Scorecard-Measures that Drive Performance. *Harvard Business Review*: 71-79
- Kaplan, R. S., Norton D. P. (1996). *The balanced scorecard: translating strategy into action*. Cambridge, MA: arvard Business School.
- Kellermann, A. L. (2006). Crisis in the Emergency Department *NEJM*; 355:1300-1303.
- Kelton, W. D., D. A. Sadowski, and R. P. Sadowski. (1998). *Simulation with ARENA*, WCB/McGraw-Hill.
- Khan, M. R. and Callahan, B. B. (1993). Planning laboratory staffing with a queueing model. *European journal of operational research*, 67, 321-331.
- Khurma, N. Bacioiu G. M., Pasek Z. J. (2008). Simulation-based verification of lean improvement for emergency room process, *Proceedings of the 2008 Winter Simulation Conference* S. J. Mason, R. R. Hill, L. Mönch, O. Rose, T. Jefferson, J. W. Fowler eds.
- Kim, S. C, I. Horowitz, K. K. Young, T. A. Buckley (1999). Analysis of capacity management of the intensive care unit in a hospital. *European Journal of Operational Research* 115, 36-46.

- Kirtland, A., J. Lockwood, K. Poisker, L. Stamp, and P. Wolfe, (1995). Simulating an emergency department is as much fun as.... Proceedings of the 1995 Winter Simulation Conference, (C Alexopoulos, K. Kang, W.R. Lilegdon, D. Goldsman, Editors), Institute of Electrical and Electronics Engineers, Washington DC, USA, 3-6 December, 1039-1042.
- Klafehn, K. A. and Connolly M., (1993), The simulation/animation of a new outpatient hematology laboratory, 1993 SCS Western Multiconference on Simulation: Simulation in the Health Sciences and Services (J.G. Anderson, M. Katzper, Editors), Society for Computer Simulation, La Jolla, California, USA, 17-20 January, 12-15.
- Klassen, K. J. and T. R. Rohleder, (1996). Scheduling outpatient appointments in a dynamic environment. *Journal of Operations Management*, 14:83-101.
- Kletke, M. G. and Dooley T. E. (1984). A simulation model of a maternity ward: A key planning tool for hospital administrators. In: Proceedings of the Conference on Simulation in Health Care Delivery Systems. San Diego, California, USA, 2-4 February, pp 35-39.
- Koelling, P., Schwandt M. J. (2005). Health systems: a dynamic system—benefits from system dynamics. Proceedings of the 2005 Winter Simulation Conference, M. E. Kuhl, N. M. Steiger, F. B. Armstrong, and J. A. Joines, eds.
- Koizumi, N., Kuno E. and Smith T. E. (2005). Modeling patient flows using a queuing network with blocking. *Health Care Management Science*, 8, 49-60.
- Kolb, E. M. W., Peck J., Schoening S., Lee T. (2008). Reducing emergency department overcrowding –five patient buffer concepts in comparison. Proceedings of the 2008 Winter Simulation Conference S. J. Mason, R. R. Hill, L. Mönch, O. Rose, T. Jefferson, J. W. Fowler eds.
- Kolker, A. (2008). Process Modeling of Emergency Department Patient Flow: Effect of Patient Length of Stay on ED Diversion. *Journal of Medical Systems*. 32:389–401.
- Kollek, D. and Walker A. F. (2002). Emergency department overcrowding. *Canadian Medical Association Journal* 167:626-627.
- Komashie A. and Mousavi A. (2005). Modeling Emergency Departments using Discrete Event Simulation Techniques, In Proceedings of the 2005 Winter Simulation Conference. M. E. Kuhl, N. M. Steiger, F. B. Armstrong, and J. A. Joines, eds. 2681-2685
- Kowalczyk, L. (2007). At the ER, the stay can reach 8 hours - Loss of beds at major Bay State hospital is blamed. *The Boston Globe*. A1. March 25, 2007.
- Kraitsik, M. J. and Bossmeyer A. (1993). Simulation Applied to Planning and Emergency Department Expansion, Proceedings of the 1993 SCS Western Multiconference on Simulation: Simulation in Health Sciences and Services, Society for Computer Simulation, La Jolla, CA. USA, pp. 19-27.

- Krochmal, P., Riley T. A. (1994). Increased health care costs associated with ED overcrowding. *Am J Emerg Med.* 12(3):265-266.
- Krug, S. E. (1999). Access and use of emergency services: inappropriate use versus unmet need. *Clin Pediatr Emerg Med.* 11:35-44.
- Kuljis, J., Paul R J., Chen C. M. (2001). Visualization and Simulation: Two sides of the same coin? *Simulation* 77 (3-4) 141-152.
- Kuljis, J., Paul R. J., Stergioulas L. K., (2007). Can health care benefit from modeling and simulation methods in the same way as business and manufacturing has? *Proceedings of the 2007 Winter Simulation Conference* S. G. Henderson, B. Biller, M.-H. Hsieh, J. Shortle, J. D. Tew, and R. R. Barton, eds.
- Kuma, A. P. and Kapur R. (1989). Discrete simulation application-scheduling staff for the emergency room, *Proceedings of the 1989 Winter Simulation Conference* (E.A. MacNair, K.J. Musselman, P. Heidelberger, Editors). 112-1120.
- Kuzdrall, P. J. Kwak N. K. and Schmitz H. H. (1981). Simulating space requirements and scheduling policies in a hospital surgical suite. *Simulation*, 27:163-171.
- Kyriacou, D. N., Ricketts V., Dyne P. L., McCollough M. D. and Talan D. A. (1999). A 5-year time study analysis of emergency department patient care efficiency. *Annals of Emergency Medicine* 34(3): 326-35.
- Lambe, S, Washington D. L., Fink A, Herbst K, Liu H, Fosse J. S, Asch SM., (2002). Trends in the use and capacity of California's emergency departments, 1990-1999. *Ann Emerg Med*, 39:389-396.
- Lambe, S., Washington D., Fink A., Laouri, M., Liu H., Scura Fosse J., Brook R. H. and Asch S.M. (2003). Waiting times in California's emergency departments. *Annals of Emergency Medicine* 41: 34-44.
- Lane, D. C., Monefeldt C. and Rosenhead J. V. (2000). Looking in the wrong place for healthcare improvements: A system dynamics study of an accident and emergency department. *Journal of the Operational Research Society* (2000) 51, 518-531.
- Lattimer, V., Brailsford S., Turnbull J., Tamaras P., Smith H., George S., Gerard K. and Maslin-Prothero S. (2004). Reviewing emergency care systems I: insights from system dynamics modelling. *Emergency Medicine Journal.* 2004;21:685-691.
- Law, A. M. and Kelton, W. D. (1991). *Simulation Modeling and Analysis*, 2nd edn, McGraw-Hill.
- Law, A. M. and W. D. Kelton (2000). *Simulation Modeling and Analysis*, 3rd Ed., New York: McGraw-Hill.
- Ledlow, G. R., Bradshaw D. M., Perry M.J. (1999). Animated Simulation: a Valuable Decision Support Tool for Practice Improvement. *Journal of Healthcare Management* 44-2.

- Lehanev, B., Clarke S. A., Paul R. J. (1999). A case of an intervention in an outpatients department. *J Ops Res Soc*, 50, 877-891.
- Lennon, J. (1992). Simulation in the design and planning of emergency departments. In: 1992 SCS Western Multiconference: Simulation in education for business, management, and MIS. Society for Computer Simulation, Newport Beach, California, USA, January, pp 93-97.
- Levin, G., Roberts, E. B. (1976). *The dynamics of human service delivery*. Cambridge, MA: Ballinger Pub., 1976.
- Lewin Group, (for the American Hospital Association). (2002). *Emergency department overload: a growing crisis. The results of the American Hospital Association Survey of Emergency Department (ED) and Hospital Capacity*. Falls Church, VA: American Hospital Association.
- Lie, S. W. et al., (2005). Frequency of adverse events and errors among patients boarding in the emergency department. *Acad Emerg Med*. 2005; 12(5)_suppl_1:49-50.
- Linard K. (2001). *Dynamic Balanced Scorecard for the Public Sector*. In International Quality and Productivity Council Conference. Canberra, Australia.
- Liyanage, L. and Gale M. (1995). *Quality Improvement for the Cambelltown Hospital Emergency Service*. Proceedings of the International Conference on Systems Man Cybernetics IEEE, Vancouver, British Columbia, Canada, pp. 1997-2002.
- Lloyd, G. C. and Aaron E. B. (2004). *Discrete Event Simulation of Emergency Department Activity: A Platform for System-level Operations Research*. *Journal of Academic Emergency Medicine*. November 2004.
- Lowery, J. C. (1992). *Simulation of a hospital's surgical suite and critical care area*. In: Swain JJ, Goldsman D, Crain RC and Wilson JR (eds). *Proceedings of the 1992 Winter Simulation Conference*. Institute of Electrical and Electronics.
- Lowery, J. C. (1994). *Barriers to Implementing Simulation in Health Care*. Proceedings of the 1994 Winter Simulation Conference WSC 94, Buena Vista, FL, USA, pp. 868-875.
- Lowery, J. C., J. A. Davies (1999). *Determination of operating room requirements using simulation*. Proceedings of the 1999 Winter Simulation Conference.
- Lucas, C. E., Buechter K. J., Coscia R. L, Hurst J. M., Meredith J. W., Middleton J. D., Rinker CR, Tuggle D, Vlahos AL, Wilberger J. (2001). *Mathematical modeling to define optimum operating room staffing needs for trauma centres*. *Journal of the American College of Surgeons* 192(5):559,565.
- Mahapatra, S., Koelling C. P., Patvivatsiri L., Fraticelli B. Eitel D., and Grove L. (2003). *Pairing emergency severity index5-level triage data with computer aided system design to improve emergency department access and throughput*. In Proceedings of the 2003 Winter Simulation Conference, S. Chick, P. J. Sanchez, D. Ferrin, and D. J. Morrice (eds), 1917-1925.

- Manchester Triage Group, Kevin Mackway-Jones, Janet Marsden, Jill Windle (2006). Emergency Triage. Second Edition, Blackwell Publishing Ltd.
- Maria, A. (1997). Introduction to modelling and simulation. Proceedings of the 1997 Winter Simulation Conference ed. S. Andradóttir, K. J. Healy, D. H. Withers, and B. L. Nelson.
- Martin, E., Grenhaug R. and Haugene K. (2003). Proposals to reduce over-crowding, lengthy stays and improve patient care: Study on the geriatric department In Norway's largest hospital, Proceedings of the 2003 Winter Simulation Conference (S. Chick, P.J. Sanchez, D. Ferrin, D.J. Morrice, Editors), 1876-1881.
- McCaig, L. F., C. W. Burt. (2004). National Hospital Ambulatory Medical Care Survey: 2002 emergency department summary. *Advance Data* 340:1-34.
- McGuire, F. (1994). Using simulation to reduce length of stay in emergency departments, Proceedings of the 1994 Winter Simulation Conference (J.D. Tew, S. Manivannan, D.A. Sadowski, A.F. Sella, Editors), December, 861-867.
- McManus, M. (2001). Emergency department overcrowding in Massachusetts: Making room in our hospitals. Issue Brief (Mass Health Policy Forum) (12), 1-38. from <http://www.sihp.brandecs.edu/mhpf/pages/publications.htm>
- McManus, M. L., Long M. C., Cooper A., Litvak E. (2004). Queuing theory accurately models the need for critical care resources. *Anesthesiology* 100(5):1271-1276.
- Meadows, D. H., Randers J., Meadows D. L. (2004). The limits to growth: the 30-year update. White River Junction, VT: Chelsea Green PubMedical Advisory Committee, Pennsylvania Emergency Health Services Council. (2004). Joint Position Statement: Guidelines for Hospital Ambulance-Diversion Policies. Mechanicsburg, PA: Pennsylvania Emergency Health Services Council.
- Meier, L, Sigal E and Vitale F. R (1985). The use of simulation model for planning ambulatory surgery. In: Gantz DT, Blais GC and Solomon SL (eds). Proceedings of the 1985 Winter Simulation Conference. Institute of Electrical and Electronics Engineers, San Francisco, California, USA, 11 - 13 December, pp 558-563.
- Miller, M. J., Ferrin D. M., Messer M. G. (2004). Fixing the Emergency Department: A Transformational Journey with EDsim. Proceedings of the 2004 Winter Simulation Conference. R. G. Ingalls, M. D. Rossetti, J. S. Smith, and B. A. Peters, eds.
- Miller, (2005). Going Lean in Healthcare, IHI White Paper.
- Miller, J. Martin and Ferrin M. David, (2003). Simulating six sigma improvement ideas for a hospital emergency department. In Proceedings of the 2003 Winter Simulation Conference, S. Chick, P. J. Sanchez, D. Ferrin, and D. J. Morrice (eds), 1926-1929.

- Minority staff special investigations division, (2001). committee on government reform. US House of Representatives. National preparedness: ambulance diversions impede access to emergency rooms. www.house.gov/reform/min, Oct 16, 2001.
- Miro, O., Antonio, M. T., Jimenez S., DeDios A., Sanchez M., Borrás A., et al. (1999). Decreased health care quality associated with emergency department overcrowding. *European Journal of Emergency Medicine*, 6(2), 105-107.
- Moorhead, J. C., Gallery M. E., Hirschkom C., et al. (1999). A study of the workforce in emergency medicine: 1999. *Ann Emerg Med*. 40 :3 –15.
- Moreno, L., R. M. Aguilar, C. A. Martin, J. D. Pineiro, J. I. Estevez, J. F. Sigut, J. L. Sanchez. (2000). Patient-centered simulation to aid decision-making in hospital management. *Simulation*. 74, 5, 290- 304.
- Moroney, S. D. (2002). Emergency and acute care system. Minneapolis, MN: National Institutes of Health Policy. Retrieved October 6, 2003, from <http://www.nihp.org/Reports/EACSRsearch1.htm>
- Morris, T. and Wood S. (1991) Testing the Survey Method: Continuity and Change in British Industrial Relations: *Work, Employment and Society*, Vol. 5, No. 2, pp. 259-82.
- Murat, M. Gunal, Michael Pidd (2006). Understanding accident and emergency department. Proceedings of the 2006 Winter Simulation Conference L. F. Perrone, F. P. Wieland, J. Liu, B. G. Lawson, D. M. Nicol, and R. M. Fujimoto, eds.
- Murray, M., and D. M. Berwick. (2003). Advanced access: reducing waiting and delays in primary care. *Journal of the American Medical Association* 289(8): 1035–1040.
- Nance, R. E. and R. G. Sargent. (2002). Perspectives on the Evolution of Simulation. *Operations Research*, Vol.50, No. 1, pp 161-172.
- Nawar, E. W., Niska R. W, Xu J. (2007). National Hospital Ambulatory Medical Care Survey-2005 Emergency Department Survey; Advance Data for Vital Health Statistics, Number 386, June 29, 2007. Available at: <http://www.cdc.gov/nchs/data/ad/ad386.pdf>. Accessed March 2008.
- Neely, A. and M. Bourne (2000). “Why measurement initiatives fail”, *Measuring Business Excellence*, Vol. 4 No. 4, pp. 3-6.
- NHS, Emergency Services Collaborative (2004). Making See and Treat work for patient and staff. London: NHS Modernisation Agency.
- Nosek Jr, R. and Wilson J. P. (2001). Queuing theory and customer satisfaction: a review of terminology, trends, and applications to pharmacy practice. *Hospital Pharmacy*, 36, 275-279.

- O'Brien Pallas, L., Birch S, Baumann A, Tomblin-Murphy G (2001). Integrated Workforce Planning, Human Resources and Service planning. World Health Organisation, Geneva.
- Ogulata, S. N., Cetik M. O., Koyuncu E., Koyuncu M. (2009). A Simulation Approach for Scheduling Patients in the Department of Radiation Oncology, *J Med Syst* (2009) 33:233–239.
- Oliveira, J. (2001). The Balanced Scorecard: An Integrative Approach to Performance Evaluation. *Healthcare Financial Management* 55(5): 42-46.
- Olson, E. and Dux LE (1994). Computer model targets best route for expanding hospital surgicenter. *Indust Engng* 26: 24-26.
- Patrick Koelling and Michael J. Schwandt (2005). Health Systems: a Dynamic System-Benefits from System Dynamics. In the Proceedings of the 2005 Winter Simulation Conference M. E. Kuhl, N. M. Steiger, F. B. Armstrong, and J. A. Joines, eds. 1321-1327.
- Patton, M. Q. (1990). *Qualitative Evaluation and Research Methods* (2nd ed.). Newbury Park, CA: Sage.
- Paw, R. C., (2008). Emergency department staffing in England and Wales, *Emerg. Med. J.* 2008; 25; 420-423,
- Pegden, C.D., R. E. Shannon and R. P. Sadowski, (1995). *Introduction to simulation using SIMAN*, 2nd Ed., New York: McGraw-Hill.
- Pexto, C. (2003). *Confronting a National Dilemma: Overcrowding, Delays and Diversion in the Emergency Department Analyzing the Issues and Identifying Solutions*, GE Medical Systems, www.gemedicalhcs.com.
- Pineno, C. J. (2002). The Balanced Scorecard: An Incremental Approach Model to Healthcare Management. *Journal of healthcare finance.* 28 (4): 69-80.
- Pines, J. M, Hollander J. E, Localio A.R, et al., (2006). The association between emergency department crowding and hospital performance on antibiotic timing for pneumonia and percutaneous intervention for myocardial infarction. *Acad Emerg Med.* 2006;13(8):873-878.
- Pines, J. M., Hollander J. E., (2007). Association between cardiovascular complications and ED crowding. *American College of Emergency Physicians 2007 Scientific Assembly*; October 8-11.
- Pink, G. H., McKillop, I., Schraa, E.G., Preyra, C., Montgomery, C., Baker, G.R. (2001). "Creating a balanced scorecard for a hospital system", *Journal of Health Care Finance*, Vol. 27 No.3, pp.1.
- Pollak, E., Falash M., Ingraham L., Gottesman V. (2004). Operational analysis framework for emergency operations center preparedness training. *Proceedings of the 2004 Winter Simulation Conference.* R .G. Ingalls, M. D. Rossetti, J. S. Smith, and B. A. Peters, eds.

- ProModel Corporation (2009). Baystate Medical Center - Emergency Department. Accessed April 2009 at: <http://www.promodel.com/solutions/healthcare/Project%20Review%20-%20Baystate%20ED.pdf>.
- Proudlove, N. C., Gordon, K., Boaden, R. (2003). Can good bed management solve the overcrowding in accident and emergency departments? *Emergency Medicine Journal*, 20(2), 149-156.
- Pulat, P. S., Kasap S, Splinter GL (2001). Simulation study of an ideal primary care delivery system. *Simulation* 76 (2): 78-86.
- QuickStats, (2003). Percentage of emergency department visits with waiting time for a physician of > 1 hour, by race/ ethnicity and triage level – United States, 2003-2004. *MMWR*. 2006;55(16);463.
- Radnor, Z. and B. Lovell (2003a). Defining, Justifying and Implementing the Balanced Scorecard in the National Health Service. *International Journal of Medical Marketing* 3(3): 174-183.
- Radnor, Z. and B. Lovell (2003b). Success Factors for Implementation of the Balanced Scorecard in A NHS Multi-Agency Setting. *International Journal of Health Care Quality Assurance* 16(2): 99-108.
- Rakich, J. S., Kuzdrall P. J., Klafehn K. A. and Krigline A. G. (1991). Simulation in the Hospital Setting: Implications for Managerial Decision Making and Management Development. *Journal of Management Development*, Vol. 10, pp. 31-37.
- Ramakrishnan, S., Nagarkar K., DeOennaro M., Srihari K., Courtney A.K., and Emick F. (2004). A study of the CT scan Area of a healthcare provider, *Proceedings of the 2004 Winter Simulation Conference* (R.G. Ingalls, M.D. Rossetti, J.S. Smith, B.A. Peters, Editors), 2025-2031.
- Ramis, F. J., Palma J.L., Estrada V.F., Coscolla G. (2002). A simulator to improve patient's service in a network of clinic laboratories. *Proceedings of the 2002 Winter Simulation Conference*.
- Rauner, M. S, S. C. Brailsford, S. Flessa (2005). Use of discrete-event simulation to evaluate strategies for the prevention of mother-to-child transmission of HIV in developing countries. *Jnl Ops Res Soc.*, 56, 222-233.
- Reeder, T. J., Locascio, E., Tucker, J., Czaplinski, T., Benson, N., Meggs, W. (2002). ED utilization: The effect of changing demographics from 1992 to 2000. *The American Journal of Emergency Medicine*, 20(7), 583-587.
- Regan, G. (2000). Making a difference to A&E: analysis of the operational inefficiencies in A&E departments in / major acute hospitals in Dublin, *Accident and Emergency Nursing* 8; 54-61.
- Reid, P. P., Compton, W. D., Grossman J. H., and Fanjiang G. (2005). Building a Better Delivery System: A New Engineering/Health Care Partnership. *National Academy of Sciences*.

- Reinus, W. R. , Enyan A, Flanagan P, Pim B, Sallee DS, Segrist J. (2000). A proposed scheduling model to improve use of computed tomography facilities. *Journal of Medical Systems* 24(2):61-76.
- Repenning, N. P., Sterman J. D. (2001). Nobody ever gets credit for fixing problems that never happened: creating and sustaining process improvement. *California Management Review* 2001; 43(4):64-88.
- Richards, J. R. (2001). Survey of directors of emergency departments in California on overcrowding. *West J Med.* 172 :385 –388
- Richards, J. R. (2004). Survey of directors of emergency departments in California Canadian Association of Emergency Physicians and the National Emergency Nurses affiliation. (2003). Joint position statement: Access to acute care in the setting of emergency department overcrowding. *Canadian Journal of Emergency Medicine*, 5(2), 81-86.
- Richardson, D. B., (2006). Increase in patient mortality at 10 days associated with emergency department overcrowding. *Med J Aust.* 2006;184(5):213-216.
- Richardson, D. B., Bryant M., (2004). Confirmation of Association between overcrowding and adverse events in patients who do not wait to be seen. *Acad Emerg Med.* 2004;11(5):462.
- Richardson, L. D., Asplin B. R., Lowe R. A. (2002). Emergency department crowding as a health policy issue: past development, future directions. *Ann Emerg Med* 2002, 40:388-393
- Richardson, L. D., Hwang U. (2001). Access to care: a review of the emergency medicine literature. *Acad Emerg Med.* 8 :1030 –1036.
- Rinker, D. Tuggle, A. L. Vlahos, and J. Wilberger. (2001). Mathematical modeling to define optimum operating room staffing needs for trauma center. *Journal of the American College of Surgeons* 192(5): 559–565.
- Ritondo, M. and Freedman R. W. (1993). The effects of procedure scheduling on emergency room throughput: A simulation study, 1993 SCS Western Multiconference on Simulation: Simulation in the Health Sciences and Services (J.G. Anderson, M. Katzper, Editors), Society for Computer Simulation, La Jolla, California, USA, 17-20 January, 8-11.
- Roberts, E. B. (1999). *Managerial applications of system dynamics*. 2nd ed Waltham, MA: Pegasus Communications, 1999.
- Robinson Stewart, (1994), *Successful Simulation – A Practical Approach to Simulation Projects*, England, McGraw-hill Book Company Europe, 0-07-707622-2.
- Robson, C. (2002) *Real World Research* (2nd edition). Oxford: Blackwell.
- Roche, K. T., Cochran, J. K. and Fulton, I. A. (2007). Improving patient safety by maximizing fast-track benefits in the emergency department – a queuing

network approach, in Proceedings of the 2007 Industrial Engineering Research Conference, pp 619-624.

Rodi, S. W., M. V. Graw and C. M. Orsini (2006). Evaluation of a fast track unit: alignment of resources and demand results in improved satisfaction and decreased length of stay for emergency department patients. *Quality Management in Health Care* 15(3): 163-170.

Rohleder, T. R., and K.J. Klassen, (2002). Rolling horizon appointment scheduling: A simulation study, *Health Care Management Science*, 5:201-209.

Rossetti, M. D., Kumar A., and Felder R. A. (1998). Mobile robot simulation of clinic laboratory deliveries, Proceedings of the 1998 Winter Simulation Conference (J.D. Medeiros, E.F. Watson, J.S. Carson, M.S. Manivannan, Editors), 1415-1421.

Rossetti, M. D., Trzcinski G. F., Syverud S. A. (1999). Emergency Department simulation and determination of optimal attending physician staffing schedules. Proceedings of the 1999 Winter Simulation Conference.

Royal College of Nursing, (2003). Setting safe nurse staffing levels. London: Royal College of Nursing.

Royal College of Nursing, (2007). Nurse workforce planning in the UK. 20 Cavendish Square, London, W1G 0RN. www.rcn.org.uk/__data/assets/pdf_file/0016/107260/003203.pdf (accessed February 23rd, 2007).

Royal College of Obstetricians, and Gynaecologists/Royal College of Midwives. (1999). Towards safer childbirth: minimum standards for the organisation of labour wards. London: Royal College of Obstetricians and Gynaecologists.

Royston, G., Dost A., Townshend J., Turner H. (1999). Using system dynamics to help develop and implement policies and programmes in health care in England. *System Dynamics Review* 15 (3): 293.

Samaha, S., Arnel S. Wendy and Starks W. Darrell, (2003). The use of simulation to reduce the length of stay in an emergency department. In Proceedings of the 2003 Winter Simulation Conference, S. Chick, P. J. Sanchez, D. Ferrin, and D. J. Morrice (eds), 1907- 1911.

Sanchez, M., A. Smally R. G. and L. Jacobs (2006). Effects of a fast-track area on emergency department performance. *The Journal of Emergency Medicine* 31(1): 117-120.

Saposnick, K. (2004). The systems thinker in every student: an interview with Mary Sheetz. *Leverage Points* 2004(46).

Saunders, C. Makens P. and Leblance L. (1989). Modeling Emergency Department Operations Using Advanced Computer Simulation Systems, *Annals of Emergency Medicine*, 134-140, Vol18, No.2, Feb 1989.

- Saunders, M., P. Lewis and A. Thornhill, (2006). *Research Methods for Business Students*, 3rd edn., Pearson Educational Ltd., Essex.
- Schafermeyer, R. W. and Brent R. A. (2003). Hospital and emergency department crowding in the United States, *Emergency Medicine* 15:22-27.
- Schmidt, J. W., and R. E. Taylor, (1970). *Simulation and Analysis of Industrial Systems*. Richard D. Irwin, Inc., Homewood, Illinois, 1970.
- Schneider, S. M., Gallery ME, Schafermeyer R, et al. (2003). Emergency department crowding: a point in time. *Ann Emerg Med.*;42:167-172.
- Schoen, C., R. Osborn, P. T. Huynh, M. Doty, K. Davis, K. Zapert, J. Peugh, (2004). Primary Care and Health System Performance: Adults. Experiences in Five Countries. *Health Affairs, Web Exclusive* (2004), pp. W4-487-503.
- Schriber, T. J. (1991). *An introduction to simulation using GPSS/H*, New York: John Wiley.
- Schull, M. J., and Mamdani M. (2001). How influenza outbreaks affect emergency department overcrowding and ambulance diversion. *Academic Emergency Medicine* 8:574.
- Schull, M. J., Lazier K, Vermeulen M, Mawhinney S, Morrison LJ (2003). Emergency department contributors to ambulance diversion: a quantitative analysis. *Ann Emerg Med*, 41:467-476.
- Secretary of State for Health (2000). *The NHS plan: A plan for investment. A plan for reform*. London: The Stationery Office.
- Sepúlveda, J. A., Thompson W. J Alvarez M. I, Baesler F., Cahoon L. E. (1999). The use of simulation for process improvement in a cancer treatment center, *Proceedings of the 1999 Winter Simulation Conference* P. A. Farrington, H. B. Nembhard, D. T. Sturrock, and G. W. Evans, eds.
- Shanks, G. and Parr A. (2003). Positivist, Single Case-study Research in Information Systems: a Critical Analysis, *Proc. European Conference on Information Systems*, Naples, June 2003.
- Shannon, R. E. (1998). Introduction to simulation. In *Proceedings of the 1998 Winter Simulation Conference*, ed. J. S. Carson, M. S. Manivannan, D. J. Medeiros, and E. F. Watson. 7-14. Washington DC, USA.
- Shannon, R. E., (1975). *Systems Simulation – The Art and Science*, Prentice-Hall.
- Shih, F. Y., Ma M. H., Chen S. C., Wang H. P., Fang C. C., Shyu R. S., Huang G. T. and Wang S. M. (1999). ED overcrowding in Taiwan: facts and strategies. *American Journal of Emergency Medicine* 17:198-202.
- Shutt, J. A. (2003). Balancing the Health Care Scorecard. *Managed Care*. September: 42-46.

- Siddharthan, K., Jones W. J, Johnson J. A. (1996). A priority queuing model to reduce waiting times in emergency care. *International Journal of Health Care Quality Assurance* 9 (5):10.16.
- Sinreich, D., Marmor Y. N. (2004) A simple and intuitive simulation tool for analyzing emergency department operations. *Proceedings of the 2004 Winter Simulation Conference*.
- Sprivilis, P. C., Da Silva J. A., Jacobs I.G., et al., (2006). The association between hospital overcrowding and mortality among patients admitted via Western Australian emergency departments. *Med J Aust*. 2006;184(5):208-212.
- Stephanie, J. Macdonald, Ika Karkam, Nasser AI-Shirrawi, Rajnisli K. Chowdhan, Esteban Morales Escalante, Afra Afandi, (2005). Emergency Department Process Improvement. In the proceeding of the 2005 Systems and Information Engineering Design Symposium Ellen J. Bass, ed. 253- 261.
- Sterman, J. D. (2000). *Business Dynamics: Systems Thinking and Modeling for a Complex World*, Irwin/McGraw-Hill.
- Sterman, J. D. , Sweeney L. B., (2002). Cloudy skies: assessing public understanding of global warming. *SystemDynamics Review* 2002;18(2):34.
- Stewart, L. J. and W. E. Bestor (2000). "Applying a Balanced Scorecard to health care organizations." *Journal of Corporate Accounting & Finance*. March/April:75-82.
- Stirling, G., Higgins J. and Cooke M.W. (2001). Violence in A&E departments: A systematic review of the literature, *Accident and Emergency Nursing* 9:77-85.
- Sun, B. C., Adams J. G., & Burstin H. R. (2001). Validating a model of patient satisfaction with emergency care. *Annals of Emergency Medicine*, 38(5), 527-532.
- Sun, B. C., Adams J. G., Orav E. J., Rucker D.W., Brennan T.A., & Burstin H.R. (2000). Determinants of patient satisfaction and willingness to return with emergency care. *Annals of Emergency Medicine*, 35(5), 426- 434.
- Sunyog, M. (2004). Lean management and Six-Sigma yield big gains in hospital's immediate response laboratory. *Quality improvement techniques save more than \$400,000. Clin Leadersh Manag Rev* 2004; 18:255-8.
- Swain, J. (2007). Biennial Survey of discrete-event simulation software tools. *OR/MS Today*, v.34, N 5, October, 2007. The Institute for Operations Research and the Management Science. Lionheart Publishing, Inc.
- Swisher, J. R. and Jacobson S. H. (2002). Evaluating the design of a family practice healthcare clinic using discrete-event simulation. *Health Care Management Science*, 5:75-88.
- Swisher, J. R., Jacobson S. H., Jun J. B, Balci O. (2001). Modelling and Analyzing a Physician Clinic Environment Using Discrete- event (visual) Simulation. *Computers & Operations Research* 28, 105-125.

- Syi Sua, Chung-Liang Shihb (2003). Modeling an emergency medical services system using computer simulation. *International Journal of Medical Informatics* 72, 57-72.
- Taha, H. (2007). *Operations research-an introduction*. MacMillan, London, New York.
- Takakuwa, S., and Shiozaki H. (2004). Functional analysis for operating emergency department of a general hospital. In *Proceedings of the 2004 Winter Simulation Conference*, R. G. Ingalls, M. D. Rossetti, J. S. Smith, and B. A. Peters (eds), 2003-2011.
- Tan, B. A., Gubaras A., and Phojanamongkolkij N. (2002). Simulation study of Dreyer urgent care facility. *Proceedings of the 2002 Winter Simulation Conference* (E. Yiicesan, C.H. Chen, J.L. Snowdon, J.M. Charnes, Editors).1922-1927.
- Tarantino, D. P. (2003). Using the Balanced Scorecard as a Performance Management Tool. *Physician Executive* 29(5): 69-72.
- Taylor, C. and Bengner J. R. (2004). Patient satisfaction in emergency medicine. *Emergency Medicine Journal* 21: 528-32.
- Taylor, D. M., Wolfe R., & Cameron P. A. (2002). Complaints from emergency department patients largely result from treatment and communication problems. *Emergency Medicine*, 14, 43-49.
- The Lewin Group, (2002). *Emergency department overload: a growing crisis — the results of the American Hospital Association Survey of Emergency Department (ED) and Hospital Capacity*. Falls Church, VA: American Hospital Association.
- The National Academy of Sciences, (2006). *Hospital-Based Emergency Care: At the Breaking Point*. National Academies Press, <http://www.nap.edu>.
- The Schumacher Group, (2002). *Emergency department overcrowding: causes and effects*. QI/RM newsletter. [Online]. Available (March 2005) at www.tsged.com/Newsletters/Emergency_Department_Overcrowding.htm.
- The Schumacher Group, (2002). *Emergency department overcrowding: causes and effects*. QI/RM newsletter. [Online]. Available (March 2005) at www.tsged.com/Newsletters/Emergency_Department_Overcrowding.htm.
- Tian, G., Bruce G. (2006). Lives in the balance: managing with the scorecard in not-for-profit healthcare settings, Australia and New Zealand Third Sector Research, Eighth Biennial Conference, 26-28.
- Timothy, W. Butler, Kirk R. Karwan, James R. Sweigart (1992). Multi-Level Strategic Evaluation of Hospital Plans and Decisions. *The Journal of the Operational Research Society*, Vol. 43, No. 7, (Jul., 1992), pp. 665- 675.
- Trout, A., Magnusson A. R. and Hedges J.R. (2000). Patient satisfaction investigations and the emergency department: what does the literature say? *Academic Emergency Medicine* 7(6): 695-709.

- Trzeciak, S., Rivers E. P., (2003). Emergency department overcrowding in the United States: an emerging threat to patient safety and public health. *Emergency Medicine Journal*. 20:402-405.
- Tucker, J.B., Barone J.E., Cecere J., Blabey R.G. and Rha C. (1999). Using queueing theory to determine operating room staffing needs. *Journal of Trauma*, 46, 71-79.
- Vasanawala, S. S. and Desser T. S. (2005). Accommodation of requests for emergency US and CT: Applications of queueing theory to scheduling of urgent studies. *Radiology*, 235, 244-249.
- Vasilakis, C. and El-Darzi E. (2001). A simulation study of the winter bed crisis, *Health Care Management Science*, 4:31-36.
- Vassilacopoulos, G. (1985). A simulation model for bed allocation to hospital inpatient departments. *Simulation* 5: 233 -241.
- Vermeulen, I. B, Bohte S. M., Elkhuizen S. G, Lameris J.-S., Bakker P. J. M., La Poutr'e J. A., (2009). Adaptive Resource Allocation for Efficient Patient Scheduling, *Artificial Intelligence in Medicine* 46, 67—80.
- Volkner, P. and Werners B. (2002). A simulation-based decision support system for business process planning. *Fuzzy Sets and Systems*, vol. 125, 2002. pp. 275-287.
- Washington, M. L. and Khator, S. K. (1997). Computer Simulation in Health Care, *Proceedings of the 1997 9th Annual Quest for Quality and Productivity in Health Services*, St. Louis, MO, USA, pp. 210-215.
- Weiss, S. J., Ernst A. A., Nick T.G. (2005). Relationship between the National ED overcrowding scale and the number of patients who leave without being seen in an academic ED. *Am J Emerg Med*. 2005;23:288-294.
- Weissman, J. S, Rothschild J. M, Bendavid E, et al. (2007). Hospital workload and adverse events. *Med Care*. 2007; 45(5):448-455.
- Weng, M. L., A. A. Houshmand. (1999). Healthcare simulation: A case study at a local clinic. *Proceedings of the 1999 Winter Simulation Conference*.
- Wiinamaki A. and Dronzek R. (2003). Using simulation in the architectural concept phase of an emergency department design. In *Proceedings of the 2003 Winter Simulation Conference*, S. Chick, P. J. Sanchez, D. Ferrin, and D. J. Morrice (eds), 1912-1916.
- Wikipedia, (2009). The free encyclopedia. http://en.wikipedia.org/wiki/Quantitative_research Access on July 2009.
- Williams, S. V (1983). How many intensive care beds are enough? *Crit Care Med* 11: 412-416.

- Wilper, A., Woolhandler S., Lasser K., McCormick D., Cutrona S., Bor D., Himmelstein D. (2008). Waits to See an Emergency Department Physician: U.S. Trends and Predictors, 1997-2004 Health Affairs Web Exclusive, January 15.
- Wolstenholme, E. F. (1999). A Patient Flow Perspective of UK Health Service, System Dynamics Review. Vol. 15, no. 3, 253-273.
- Womack, J. P., Jones D. T. (1996). Lean thinking. London: Simon and Schuster.
- Wong, C., Geiger G., Derman Y. D., Busby C. R., Carter M. W. (2003). Redesigning the medication ordering, dispensing and administration process in an acute care academic health sciences centre. Proceedings of the 2003 Winter Simulation Conference.
- Yin, R. K. (2003). Case Study Research: Design and Method (3rd edition). London: Sage.
- Yoon, P., Steiner I. & Reinhardt G. (2003). Analysis of factors influencing length of stay in the emergency department. The Journal of the Canadian Association of Emergency Physicians, 5(3), 155-162.
- Zelman, W. N., G. H. Pink, C. B. Matthias (2003). Use of the Balanced Scorecard in Health Care. Journal of Health Care Finance 29(4): 1-16.
- Zilm, F., Arch D. and Hollis R. B. (1983). An application of simulation modeling to surgical intensive care bed need analysis in a university hospital. Hospital & Health Services Admin 28: 82-101.

Appendix 1

Required Resources for EDs

American College of Emergency Physicians (2007) suggested following equipment and supplies; Radiologic, imaging, and other diagnostic services; Laboratory capabilities; Pharmacological/therapeutic drugs for EDs.

1. Equipment and supplies for EDs

Entire Department

- Central station monitoring capability
- Physiological monitors
- Blood flow detectors
- Defibrillator with monitor and battery
- Thermometers
- Pulse oximetry
- Nurse-call system for patient use
- Portable suction regulator
- Infusion pumps to include blood pumps
- IV poles
- Bag-valve-mask respiratory and adult and pediatric size mask
- Portable oxygen tanks
- Blood/fluid warmer and tubing
- Nasogastric suction supplies
- Nebulizer
- Gastric lavage supplies, including large-lumen tubes and bite blocks
- Urinary catheters, including straight catheters, Foley catheters, Coude catheters, filiforms and followers, and appropriate collection equipment
- Intraosseous needles
- Lumbar puncture sets (adult and pediatric)
- Blanket warmer
- Tonometer
- Slit lamp
- Wheelchairs
- Medication dispensing system with locking capabilities
- Separately wrapped instruments (specifics will vary by department)
- Availability of light microscopy for emergency procedures
- Weight scales (adult and infant)
- Tape measure
- Ear irrigation and cerumen removal equipment
- Vascular Doppler
- Anoscope
- Adult and Pediatric “code” cart Suture or minor surgical procedure sets (generic)
- Portable sonogram equipment
- ECG machine
- Point-of-care testing
- X-ray view box and hot light
- Film boxes for holding x-rays
- Chart rack
- Computer system
- Internet capabilities
- Patient tracking system
- Radio or other device for communication with ambulances
- Patient discharge instruction system
- Patient registration system/Information services
- Intradepartmental staff communication system: pagers, mobile phones
- ED charting system for physician, nursing, and attending physician documentation equipment
- Reference materials including

- toxicology resource information
- Personal protective equipment: gloves, eye goggles, face mask, gowns, head and foot covers
- Linen (pillows, towels, wash cloths, gowns, blankets)
- Patient belongings or clothing bag
- Security needs, including restraints and wand-type or freestanding metal detectors as indicated
- Equipment for adequate housekeeping

General Examination Rooms

- Examination tables or stretchers appropriate to the area. (For any area in which seriously ill patients are managed, a stretcher with capability for changes in position, attached IV poles, and a holder for portable oxygen tank should be used. Pelvic tables for GYN examinations.)
- Step stool
- Chair/stool for emergency staff
- Seating for family members or visitors
- Adequate lighting, including procedure lights as indicated
- Cabinets
- Adequate sinks for hand-washing, including dispensers for germicidal soap and paper towels
- Wall-mounted oxygen supplies and equipment, including nasal cannulas, face masks, and venturi masks.
- Wall-mounted suction capability, including both tracheal cannulas and larger cannulas
- Wall-mounted or portable otoscope/ophthalmoscope
- Sphygmomanometer/stethoscope
- Oral and nasal airways
- Televisions
- Reading material for patients
- Biohazard-disposal receptacles, including for sharps
- Garbage receptacles for non-

-contaminated materials

Resuscitation Room

All items listed for general examination rooms plus:

- Adult and Pediatric “code cart” to include appropriate medication charts
- Capability for direct communication with nursing station, preferably hands free
- Radiography equipment
- Radiographic view boxes and hot light
- Airways needs
 - Bag-valve-mask respirator (adult, pediatric, and infant)
 - Cricothyroidotomy instruments and supplies
 - Endotracheal tubes, size 2.5 to 8.5 mm
 - Fiberoptic laryngoscope
 - Laryngoscopes, straight and curved blades and stylets
 - Laryngoscopic mirror and supplies
 - Laryngeal Mask Airway (LMA)
 - Oral and nasal airways
 - Tracheostomy instrument and supplies
- Breathing
 - BiPAP Ventilation System
 - Closed-chest drainage device
 - Chest tube instruments and supplies
 - Emergency thoracotomy instruments and supplies
 - End-tidal CO₂ monitor
 - Nebulizer
 - Peak flow meter
 - Pulse oximetry
 - Volume cycle ventilator
- Circulation
 - Automatic physiological monitor, noninvasive
 - Blood/fluid infusion pumps and tubing
 - Blood/fluid warmers
 - Cardiac compression board

Central venous catheter setups/kits
Central venous pressure monitoring equipment
Cutdown instruments and supplies
Intraosseous needles
IV catheters, sets, tubing, poles
Monitor/defibrillator with pediatric paddles, internal paddles, appropriate pads, and other supplies
Pericardiocentesis instruments
Temporary external pacemaker
Transvenous and/or transthoracic pacemaker setup and supplies
12-Lead ECG machine

Trauma and Miscellaneous Resuscitation

- Blood salvage/autotransfusion device
- Emergency obstetric instruments and supplies
- Hypothermia thermometer
- Infant warming equipment
- Peritoneal lavage instruments and supplies
- Pneumatic antishock garment, as indicated
- Spine stabilization equipment to include cervical collars, short and long boards
- Warming/cooling blanket

Other Special Rooms

All items listed for general examination rooms plus:

- Orthopedic
Cast cutter
Cast and splint application supplies and equipment
Cast spreader
Crutches
Extremity-splinting devices including traction splinting and fixation pins/wires and corresponding instruments and supplies
Halo traction or Gardner-

Wells/Trippe-Wells traction
Radiograph view and hot light
Suture instrument and supplies
Traction equipment, including hanging weights and finger traps

- Eye/ENT
Eye chart
Ophthalmic tonometry device (applanation, Schiotz, or other)
Other ophthalmic supplies as indicated, including eye spud, rust ring remover, cobalt blue light
Slit lamp
Ear irrigation and cerumen removal equipment
Epistaxis instrument and supplies, including balloon
posterior packs
Frazier suction tips
Headlight
Laryngoscopic mirror
Plastic suture instruments and supplies
- OB-GYN
- Fetal Doppler and ultrasound equipment
Obstetrics/Gynecology examination light
Vaginal specula in pediatric through adult sizes
Sexual assault evidence-collection kits (as appropriate)
Suture material

Miscellaneous

- Nitrous Oxide equipment

2. Radiologic, imaging, and other diagnostic services for ED

The following should be readily available 24 hours a day for emergency patients:

Standard radiologic studies of bony and soft-tissue structures including, but not limited to

- Cross-table lateral views of spine with full series to follow
- Portable chest radiographs for acutely ill patients and for verification of placement of endotracheal tube, central line, or chest tube
- Soft-tissue views of the neck
- Soft-tissue views of subcutaneous tissues to rule out the presence of foreign body
- Standard chest radiographs, abdominal series, etc

Pulmonary services

- Arterial blood gas determination
- Peak flow determination
- Pulse oximetry

Fetal monitoring (nonstress test)/uterine monitoring

Cardiovascular services

- Doppler studies
- 12-Lead ECGs and rhythm strips

Emergency ultrasound services for the diagnosis of obstetric/gynecologic, cardiac and hemodynamic problems and other urgent conditions.

The following services should be available on an urgent basis, provided by staff in the hospital or by staff to be called in to respond within a reasonable period of time:

Nuclear medicine

- Ventilation-perfusion lung scans
- Other scintigraphy for trauma and other conditions

Radiographic

- Arteriography/venography
- Computed tomography
- Dye-contrast studies (intravenous pyelography, gastrointestinal contrast, etc)

Vascular/flow studies including impedance plethysmography

3. Laboratory capabilities for ED

Blood bank

Bank products availability
Type and cross-matching capabilities

Chemistry

Ammonia
Amylase
Anticonvulsant and other therapeutic drug levels
Arterial blood gases
Bilirubin (total and direct)
Calcium
Carboxyhemoglobin
Cardiac isoenzymes (including creatine kinase-MB)
Chloride (blood and cerebrospinal fluid [CSF])
Creatinine
Electrolytes
Ethanol
Glucose (blood and CSF)
Liver-function enzymes (ALT, AST, alkaline phosphatase)
Methemoglobin
Osmolality
Protein (CSF)
Serum magnesium
Urea nitrogen

Hematology

Cell count and differential (blood, CSF, and joint fluid analysis)
Coagulation studies
Erythrocyte sedimentation rate
Platelet count
Reticulocyte count
Sickle cell prep

Microbiology

Acid fast smear/staining
Chlamydia testing
Counterimmune electrophoresis for bacterial identification
Gram staining and culture/sensitivities
Herpes testing
Strep screening
Viral culture
Wright stain

Other

Hepatitis screening
HIV screening
Joint fluid and CSF analysis
Toxicology screening and drug levels
Urinalysis
Mononucleosis spot
Serology (syphilis, recombinant immunoassay)
Pregnancy testing (qualitative and quantitative)

4. Pharmacological/therapeutic drugs for EDs

Analgesics	Fluid replacement solutions
narcotic and non-narcotic	Gastrointestinal agents
Anesthetics	Antacids
topical, infiltrative, general	Anti-diarrheals
Anticonvulsants	Emetics and Anti-emetics
Antidiabetic agents	Anti-flatulent
Antidotes	Anti-spasmodics
antivenins	Bowel evacuants/laxatives
Antihistamines	Histamine receptor antagonists
Anti-infective agents	Proton pump inhibitors
systemic/topical	
Anti-inflammatories	Glucose elevating agents
steroidal/non-steroidal	Hormonal agents
Bicarbonates	Oral contraceptives
Blood Modifiers	Steroid preparations
Anticoagulants to include	Thyroid preparations
thrombolytics	Hypocalcemia and hypercalcemia
Anticoagulants	management agents
Hemostatics	Lubricants
systemic	Migraine preparations
topical	Muscle relaxants
plasma expanders/extenders	Narcotic antagonist
Burn Preparations	Nasal preparation
Cardiovascular agents	Ophthalmologic preparations
Ace inhibitors	Otic preparations
Adrenergic blockers	Oxytocics
Adrenergic stimulants	Psychotherapeutic agents
Alpha/Beta blockers	Respiratory agents
Antiarrhythmia agents	Antitussives
Calcium channel blockers	Bronchodilators
Digoxin antagonist	Decongestants
Diuretics	Leukotriene antagonist
Vasodilators	Rh0(D) immune globulin
Vasopressors	Salicylates
Cholinesterase Inhibitors	Sedatives and Hypnotics
Diagnostic agents	Vaccinations
Blood contents	Vitamins and minerals
Stool contents	
Testing for myasthenia gravis	
Urine contents	
Electrolytes	
Cation exchange resin	
Electrolyte replacements,	
parenteral and oral	

Appendix 2

Paired T-test to compare the hourly patient-arrivals between the days of the week

Paired T-Test and CI: Sunday count, Monday Count

Paired T for Sunday count - Monday Count

	N	Mean	StDev	SE Mean
Sunday count	24	292.750	199.904	40.805
Monday Count	24	268.958	185.680	37.902
Difference	24	23.7917	69.2079	14.1270

95% CI for mean difference: (-5.4323, 53.0156)

T-Test of mean difference = 0 (vs not = 0): T-Value = 1.68 P-Value = 0.106

Paired T-Test and CI: Tuesday Count, Monday Count

Paired T for Tuesday Count - Monday Count

	N	Mean	StDev	SE Mean
Tuesday Count	24	243.750	174.744	35.669
Monday Count	24	268.958	185.680	37.902
Difference	24	-25.2083	31.4061	6.4108

95% CI for mean difference: (-38.4700, -11.9467)

T-Test of mean difference = 0 (vs not = 0): T-Value = -3.93 P-Value = 0.001

Paired T-Test and CI: Tuesday Count, Wed Count

Paired T for Tuesday Count - Wed Count

	N	Mean	StDev	SE Mean
Tuesday Count	24	243.750	174.744	35.669
Wed Count	24	235.542	166.393	33.965
Difference	24	8.20833	29.41603	6.00452

95% CI for mean difference: (-4.21296, 20.62963)

T-Test of mean difference = 0 (vs not = 0): T-Value = 1.37 P-Value = 0.185

Paired T-Test and CI: Wed Count, Thursday count

Paired T for Wed Count - Thursday count

	N	Mean	StDev	SE Mean
Wed Count	24	235.542	166.393	33.965
Thursday count	24	252.292	182.526	37.258
Difference	24	-16.7500	29.6197	6.0461

95% CI for mean difference: (-29.2573, -4.2427)

T-Test of mean difference = 0 (vs not = 0): T-Value = -2.77 P-Value = 0.011

Paired T-Test and CI: Friday Count, Thursday count

Paired T for Friday Count - Thursday count

	N	Mean	StDev	SE Mean
Friday Count	24	233.667	154.305	31.497
Thursday count	24	252.292	182.526	37.258
Difference	24	-18.6250	41.0724	8.3839

95% CI for mean difference: (-35.9683, -1.2817)

T-Test of mean difference = 0 (vs not = 0): T-Value = -2.22 P-Value = 0.036

Paired T-Test and CI: Friday Count, Sat Count

Paired T for Friday Count - Sat Count

	N	Mean	StDev	SE Mean
Friday Count	24	233.667	154.305	31.497
Sat Count	24	264.417	173.587	35.433
Difference	24	-30.7500	51.3566	10.4831

95% CI for mean difference: (-52.4360, -9.0640)

T-Test of mean difference = 0 (vs not = 0): T-Value = -2.93 P-Value = 0.007

Paired T-Test and CI: Sunday count, Sat Count

Paired T for Sunday count - Sat Count

	N	Mean	StDev	SE Mean
Sunday count	24	292.750	199.904	40.805
Sat Count	24	264.417	173.587	35.433
Difference	24	28.3333	36.1971	7.3887

95% CI for mean difference: (13.0486, 43.6180)

T-Test of mean difference = 0 (vs not = 0): T-Value = 3.83 P-Value = 0.001

Appendix 3

Paired T-test to compare the daily patient-arrivals between the months of the year

Paired T-Test and CI: January, February

Paired T for January - February

	N	Mean	StDev	SE Mean
January	28	110.75	16.02	3.03
February	28	108.71	17.37	3.28
Difference	28	2.04	21.64	4.09

95% CI for mean difference: (-6.35, 10.43)

T-Test of mean difference = 0 (vs not = 0): T-Value = 0.50 P-Value = 0.623

Paired T-Test and CI: February, March

Paired T for February - March

	N	Mean	StDev	SE Mean
February	28	108.71	17.37	3.28
March	28	135.93	23.18	4.38
Difference	28	-27.21	31.99	6.04

95% CI for mean difference: (-39.62, -14.81)

T-Test of mean difference = 0 (vs not = 0): T-Value = -4.50 P-Value = 0.000

Paired T-Test and CI: March, April

Paired T for March - April

	N	Mean	StDev	SE Mean
March	30	133.47	24.70	4.51
April	30	123.30	18.51	3.38
Difference	30	10.17	32.19	5.88

95% CI for mean difference: (-1.85, 22.19)

T-Test of mean difference = 0 (vs not = 0): T-Value = 1.73 P-Value = 0.094

Paired T-Test and CI: April, May

Paired T for April - May

	N	Mean	StDev	SE Mean
April	30	123.30	18.51	3.38
May	30	139.30	15.13	2.76
Difference	30	-16.00	25.85	4.72

95% CI for mean difference: (-25.65, -6.35)
T-Test of mean difference = 0 (vs not = 0): T-Value = -3.39 P-Value = 0.002

Paired T-Test and CI: May, June

Paired T for May - June

	N	Mean	StDev	SE Mean
May	30	139.30	15.13	2.76
June	30	127.40	21.25	3.88
Difference	30	11.90	26.36	4.81

95% CI for mean difference: (2.06, 21.74)
T-Test of mean difference = 0 (vs not = 0): T-Value = 2.47 P-Value = 0.020

Paired T-Test and CI: June, July

Paired T for June - July

	N	Mean	StDev	SE Mean
June	30	127.40	21.25	3.88
July	30	117.73	24.36	4.45
Difference	30	9.67	35.89	6.55

95% CI for mean difference: (-3.74, 23.07)
T-Test of mean difference = 0 (vs not = 0): T-Value = 1.48 P-Value = 0.151

Paired T-Test and CI: July, August

Paired T for July - August

	N	Mean	StDev	SE Mean
July	31	117.52	23.98	4.31
August	31	95.29	13.61	2.45
Difference	31	22.23	30.01	5.39

95% CI for mean difference: (11.22, 33.24)
T-Test of mean difference = 0 (vs not = 0): T-Value = 4.12 P-Value = 0.000

Paired T-Test and CI: August, September

Paired T for August - September

	N	Mean	StDev	SE Mean
August	29	95.93	13.76	2.56
September	29	110.41	19.97	3.71
Difference	29	-14.48	26.50	4.92

95% CI for mean difference: (-24.56, -4.40)
T-Test of mean difference = 0 (vs not = 0): T-Value = -2.94 P-Value = 0.006

Paired T-Test and CI: September, October

Paired T for September - October

	N	Mean	StDev	SE Mean
September	29	110.41	19.97	3.71
October	29	114.34	19.50	3.62
Difference	29	-3.93	35.42	6.58

95% CI for mean difference: (-17.41, 9.54)

T-Test of mean difference = 0 (vs not = 0): T-Value = -0.60 P-Value = 0.555

Paired T-Test and CI: October, November

Paired T for October - November

	N	Mean	StDev	SE Mean
October	30	114.57	19.20	3.51
November	30	120.77	16.80	3.07
Difference	30	-6.20	25.01	4.57

95% CI for mean difference: (-15.54, 3.14)

T-Test of mean difference = 0 (vs not = 0): T-Value = -1.36 P-Value = 0.185

Paired T-Test and CI: November, December

Paired T for November - December

	N	Mean	StDev	SE Mean
November	30	120.77	16.80	3.07
December	30	114.20	20.28	3.70
Difference	30	6.57	28.07	5.13

95% CI for mean difference: (-3.92, 17.05)

T-Test of mean difference = 0 (vs not = 0): T-Value = 1.28 P-Value = 0.210

Paired T-Test and CI: December, January

Paired T for December - January

	N	Mean	StDev	SE Mean
December	31	113.71	20.13	3.62
January	31	111.06	15.28	2.74
Difference	31	2.65	25.86	4.65

95% CI for mean difference: (-6.84, 12.13)

T-Test of mean difference = 0 (vs not = 0): T-Value = 0.57 P-Value = 0.573

Introduction to IDEF0

Integration Definition for Function Modeling (IDEF0) is a method designed to model the decisions, actions, and activities of an organization or system. IDEF0 was derived from a well-established graphical language, the Structured Analysis and Design Technique (SADT). The United States Air Force commissioned the developers of SADT to develop a function modeling method for analyzing and communicating the functional perspective of a system. Effective IDEF0 models help to organize the analysis of a system and to promote good communication between the analyst and the customer. IDEF0 is useful in establishing the scope of an analysis, especially for a functional analysis. As a communication tool, IDEF0 enhances domain expert involvement and consensus decision-making through simplified graphical devices. As an analysis tool, IDEF0 assists the modeler in identifying what functions are performed, what is needed to perform those functions, what the current system does right, and what the current system does wrong. Thus, IDEF0 models are often created as one of the first tasks of a system development effort.

The IDEF0 method is used to specify function models. IDEF0 allows the user to depict a view of the process including the Inputs, outputs, controls and mechanisms (which are referred to generally as ICOMs). In an IDEF0 model, the central box represents the activity, described by an activity name beginning with a verb. As shown in figure A-1, arrow enter and exit the box. The arrows from the left represent inputs to a activity and arrows coming out from the right represent the outputs that the activity produces by the transforming or consuming its inputs. The arrows coming from the top are controls, which constrain or control when or how the activity is accomplished. The mechanisms, the resources (people or manual and automated tools) used to execute activity, enter from the bottom.

The IDEF0 diagrams may be decomposed into lower level diagrams. The hierarchy is maintained via a numbering system that organises parent and child diagrams. Normally, the IDEF0 model starts from a general representation of the system. This representation is called A0 diagram. The decomposition process can be performed further breaking

down the A0 diagram into sub-diagrams to describe as required the level of details as shown in figure A-2.

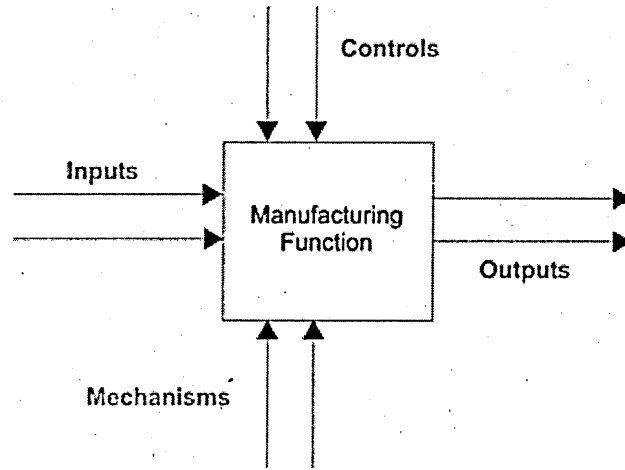

Figure A-1: A generic IDE0 Diagram

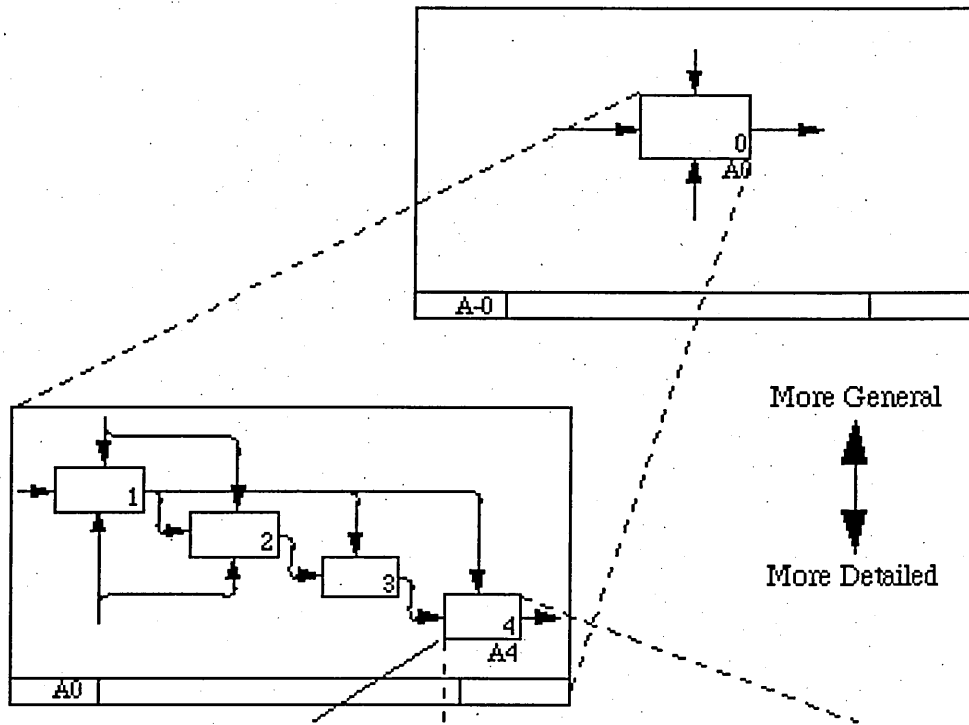

Figure A-2: Decomposition Diagram

Strengths of IDEF0

- The model has proven effective in detailing the system activities for function modeling.
- IDEF0 models provide an abstraction away from timing, sequencing and decision logic. However, it is easy to use IDEF0 for modeling activity sequences whenever needed. (Order the activities from left to right in the decomposition diagram).
- Provides a concise description of systems, by using the ICOMS. (Inputs, Controls, Output, Mechanism)
- The hierarchical nature of IDEF0 allows the system to be easily refined into greater detail until the model is as descriptive as necessary for the decision making task.

Weaknesses of IDEF0

- IDEF models might be so concise that only the domain experts can understand.
- IDEF models are sometimes misinterpreted as representing a sequence of activities.
- The abstraction away from timing, sequencing and decision logic leads to comprehension difficulties for the people outside the domain.

References

1. Ovidiu S. Noran (2000). Business Modelling: UML vs. IDEF Paper Griffith University
2. Robert P. (1995). Hanrahan The IDEF Process Modeling Methodology. Software Technology Support Center.
3. www.idef.com is maintained by Knowledge Based Systems, Inc.
4. Computer Systems Laboratory of the National Institute of Standards and Technology (NIST) (1993). FIPS Publication 183 released of IDEF0 December 1993

Appendix 5

The Schedule for the Validation of the Decisions-framework

Modelling Based Framework for the Management of EDs Sheffield Hallam University

1. What is your current profession in the hospital?

2. How long have you been involving in the decision making in the ED?

2.1 Under 5 years

2.2 5-10 years

2.3 10-20 years

2.4 Over 20 years

3. How do you agree with the decision-levels and decision categories in this framework?

		SA	A	DA	NI	Remarks
3.1	decision-levels in the framework					
3.2	decision categories in the framework					

SA=Strongly Agree; A=Agree; DA=Disagree; NI=No Idea

4. How do you agree with the selected decisions for this framework?

		SA	A	DA	NI	Remarks
Strategic-level (long-term) Decisions						
4.1	Introducing new policy or changes					
4.2	Planning and recruiting workforce					
4.3	Planning facilities and technology					
Tactical-level (medium-term) Decisions						
4.4	Improving ED process					
4.5	Scheduling staff					
4.6	Allocating resources and equipments					
Operational-level (short-term) Decisions						
4.7	Managing patient-flows					
4.8	Scheduling patients for doctors					
4.9	Scheduling patients for shared resources					

SA=Strongly Agree; A=Agree; DA=Disagree; NI=No Idea

5. Do you agree with the identified outcomes of each decision in the framework?

		Yes	No	Remarks
5.1	Introducing new policy or changes			
5.2	Planning and recruiting workforce			
5.3	Planning facilities and technology			
5.4	Improving ED process			
5.5	Scheduling staff			
5.6	Allocating resources and equipments			
5.7	Managing patient-flows			
5.8	Scheduling patients for doctors			
5.9	Scheduling patients for shared resources			

6. Have you indentified a requirement of a suitable tool or technique in making the given decisions in efficient and effective manner?

6.1	Yes	
6.2	No	

7. What is your opinion about this decisions-framework?