

Applications of dynamical systems theory and 'complex' analyses to cricket fast bowling.

GLAZIER, Paul S.

Available from Sheffield Hallam University Research Archive (SHURA) at:

<http://shura.shu.ac.uk/20686/>

This document is the author deposited version. You are advised to consult the publisher's version if you wish to cite from it.

Published version

GLAZIER, Paul S. (2011). Applications of dynamical systems theory and 'complex' analyses to cricket fast bowling. Doctoral, Sheffield Hallam University (United Kingdom)..

Copyright and re-use policy

See <http://shura.shu.ac.uk/information.html>

102 070 944 8

<

REFERENCE

ProQuest Number: 10702781

All rights reserved

INFORMATION TO ALL USERS

The quality of this reproduction is dependent upon the quality of the copy submitted.

In the unlikely event that the author did not send a complete manuscript and there are missing pages, these will be noted. Also, if material had to be removed, a note will indicate the deletion.

uest

ProQuest 10702781

Published by ProQuest LLC(2017). Copyright of the Dissertation is held by the Author.

All rights reserved.

This work is protected against unauthorized copying under Title 17, United States Code
Microform Edition © ProQuest LLC.

ProQuest LLC.
789 East Eisenhower Parkway
P.O. Box 1346
Ann Arbor, MI 48106- 1346

Applications of Dynamical Systems Theory and ‘Complex’ Analyses to Cricket Fast Bowling

Paul S Glazier

A thesis submitted in partial fulfilment of the requirements of
Sheffield Hallam University
for the degree of Doctor of Philosophy

October 2011

Fast bowling - a highly dynamic and coordinated motor skill.
This photograph shows 'Firey' Fred Trueman in full flow against the 1952 Indians.
© International Cricket Council

To Mum and Dad

ABSTRACT

The aims of this thesis were to: (i) increase understanding of the biomechanical and motor control processes that underpin proficient fast bowling performance using dynamical systems theory and 'complex' analyses; and (ii) demonstrate the application of dynamical systems theory and the utility of 'complex' analyses to performance-oriented sports biomechanics research using cricket fast bowling as a representative task vehicle.

Prior to analysing within- and between-bowler differences in coordination patterns at different levels of analysis and their relationship to ball release speed, the suitability of manual coordinate digitising for analysing intra- and inter-individual variability was examined. Both the reliability of time-discrete and time-continuous kinematic variables was considered. Of the 33 time-discrete kinematic variables examined, 31 exhibited between-participant variances and re-digitisation variances that accounted for the largest and smallest portions of total variance, respectively. Furthermore, re-digitisation variance accounted for less than 5% of total variance in 29 of these variables with 15 of these exhibiting less than 1%. For the 45 time-continuous kinematic variables, measurement error accounted for 17.2% of movement variability (range 4.3-41.0%). When considered together, these results indicated that manual coordinate digitising was sufficiently sensitive to reliably measure differences in technique within and between bowlers.

Kohonen Self-Organising Maps (SOMs) were used to analyse coordination patterns in cricket fast bowling at a global whole-body level of analysis. Qualitative differences in SOM trajectories between bowlers signified participant-specific coordination patterns, which were attributed to differences in organismic constraints and intrinsic dynamics. A theoretical argument against the common optimal movement pattern concept was constructed and the utility of SOMs was evaluated. Several issues currently limiting their practical application, including the difficulty in linking the SOM trajectory to aspects of technique and the inability of biomechanists to identify optimal sports techniques, were highlighted.

A combination of 'complex' analytical techniques was then applied to quantify intersegmental coordination among key limb and torso segments. Cross-correlation functions showed that moderate (0.5+) to very strong (0.9+) coupling relationships existed for the four segment couplings (NBA vs. FL, BA vs. NBA, BA vs. FL, UT vs. P) with the majority of these moving in synchrony. Statistically significant mean differences in both cross-correlation coefficients and average coupling angle for the four segment couplings throughout (0-100%), and during different phases (0-24%, 25-49%, 50-74%, 75-99%) of, the delivery stride provided further evidence of participant-specific coordination patterns. However, no associations between coupling relationships and ball release speed could be identified either within or between bowlers. This study further highlighted the difficulties in making associations between technique and outcomes.

It was concluded that, based on the reported research findings, dynamical systems theory and its associated 'complex' analyses could make a substantive contribution to the enhancement of knowledge of cricket fast bowling techniques and also advance applied sports biomechanics research more generally. Further investigations into cricket fast bowling performance, focusing on the link between technique and outcomes using a combination of kinetic, energetic and coordination analyses, were identified as a research priority.

LIST OF PUBLICATIONS

Parts of this thesis have been reproduced in the following publications:

Glazier, P.S., Davids, K. & Bartlett, R.M. (2003). Dynamical systems theory: a relevant framework for performance-oriented sports biomechanics research. *Sportscience*, 7 (<http://www.sportsci.org>).

Glazier, P.S., Wheat, J.S., Pease, D.L. & Bartlett, R.M. (2006). The interface of biomechanics and motor control: Dynamic systems theory and the functional role of movement variability. In *Movement System Variability* (edited by K. Davids, S.J. Bennett & K.M. Newell), pp. 49-69. Champaign, IL: Human Kinetics.

Glazier, P.S. & Davids, K. (2009). Constraints on the complete optimization of human motion. *Sports Medicine*, **39**, 15-28.

Glazier, P.S. & Davids, K. (2009). The problem of measurement indeterminacy in complex neurobiological movement systems. *Journal of Biomechanics*, **42**, 2694-2696.

Davids, K. & Glazier, P.S. (2010). Deconstructing neurobiological coordination: The role of the biomechanics-motor control nexus. *Exercise and Sport Sciences Reviews*, **38**, 86-90.

Glazier, P.S. (2010). Game, set and match? Substantive issues and future directions in performance analysis. *Sports Medicine*, **40**, 625-634.

Glazier, P.S. (2010). Is the 'crunch factor' an important consideration in the aetiology of lumbar spine pathology in cricket fast bowlers? *Sports Medicine*, **40**, 809-815.

Glazier, P.S. (2011). Movement variability in the golf swing: Theoretical, methodological, and practical issues. *Research Quarterly for Exercise and Sport*, **82**, 157-161.

ACKNOWLEDGMENTS

This thesis is a product of a 'search and refinement' process over an extended timescale. I would like to thank the following people who have helped me along the way:

Dr. Jon Wheat for his input and advice on empirical issues and his assistance with MATLAB programming and operation.

Prof. Steve Haake for facilitating a seamless transfer of registration to Sheffield Hallam University and for the financing of my student and publication fees.

Prof. Keith Davids for his input on theoretical issues and assistance with publication writing early on in the process.

Dr. Stephen-Mark Cooper and Laurence Llewellyn for their advice on statistical issues.

TABLE OF CONTENTS

ABSTRACT	i
LIST OF PUBLICATIONS	ii
ACKNOWLEDGEMENTS	iii
TABLE OF CONTENTS	iv
LIST OF FIGURES	viii
LIST OF TABLES	x
CHAPTER I - INTRODUCTION	
1.0 Historical Background	1
1.1 Focus of this Thesis	1
1.2 Research Question	3
1.3 Aims and Objectives	3
1.4 Structure of this Thesis	4
CHAPTER II - REVIEW OF THE LITERATURE: BIOMECHANICS OF FAST BOWLING PERFORMANCE	
2.0 Introduction	7
2.1 Biomechanical Factors Associated with Ball Release Speed	8
2.2 Biomechanical Factors Associated with Bowling Accuracy	19
2.3 Summary of Key Research Findings	21
2.4 Limitations of Existing Studies and Opportunities for Further Research	23
CHAPTER III - THEORETICAL DEVELOPMENT OF THE BIOMECHANICS-MOTOR CONTROL NEXUS	
3.0 Introduction	24
3.1 Movement Systems as Dynamical Systems	24
3.2 Implications of Dynamical Systems Theory for Sports Biomechanics	29
3.2.1 Hypothesis Generation	29
3.2.2 Research Design	30
3.2.3 Experimentation	32
3.2.4 Inverse Dynamics Analyses	35
3.2.5 Forward Dynamics Analyses	36
3.2.6 ‘Complex’ Analyses	39

3.2.7	Interpretations of Movement Variability	42
3.3	Summary	45
 CHAPTER IV – METHODS		
4.0	Introduction	47
4.1	Participants	47
4.2	Experimental Protocol	47
4.3	Data Collection	48
4.4	Data Reconstruction	50
4.5	Data Processing	53
 CHAPTER V – THE SUITABILITY OF MANUAL COORDINATE DIGITISING FOR ANALYSING INTER- AND INTRA-INDIVIDUAL MOVEMENT VARIABILITY		
5.0	Introduction	55
5.1	Method	57
5.1.1	Data Analysis – Time-Discrete Data	57
5.1.2	Data Analysis – Time-Continuous Data	59
5.2	Results	59
5.2.1	Reliability of Time-Discrete Data	59
5.2.2	Reliability of Time-Continuous Data	62
5.3	Discussion	62
5.4	Conclusion	66
 CHAPTER VI – ANALYSING CRICKET FAST BOWLING TECHNIQUES USING KOHONEN SELF-ORGANISING MAPS		
6.0	Introduction	67
6.1	Method	69
6.1.1	Data Analysis	69
6.2	Results	70
6.3	Discussion	72
6.3.1	Magnitude and Origin of Individual Differences	72
6.3.2	Utility and Practical Application of SOMs	73
6.4	Conclusion	75

CHAPTER VII – RELATIONSHIPS BETWEEN INTERSEGMENTAL COORDINATION AND BALL RELEASE SPEED: A MULTIPLE SINGLE-PARTICIPANT ANALYSIS

7.0	Introduction	76
7.1	Method	77
7.1.1	Data Analysis	77
7.1.2	Statistical Analysis	81
7.2	Results	84
7.2.1	Ball Release Speed	84
7.2.2	Cross-Correlation Analysis	86
7.2.3	Vector Coding Analysis	90
7.3	Discussion	110
7.3.1	Cross-Correlation Analysis	110
7.3.2	Vector Coding Analysis	112
7.4	Conclusion	115

CHAPTER VIII – GENERAL DISCUSSION AND RECOMMENDATIONS FOR FUTURE RESEARCH

8.0	Introduction	116
8.1	Summary of Research	116
8.2	Implications for Coaching Cricket Fast Bowling and Other Sports Techniques	119
8.3	Concluding Remarks and Recommendations for Future Research	120

CHAPTER IX – REFERENCES 122

APPENDIX A – INFORMED CONSENT PROFORMA

APPENDIX B – USER-DEFINED SPATIAL MODEL OF THE HUMAN PERFORMER

APPENDIX C – ROOT-MEAN-SQUARE (RMS) CALIBRATION AND RECONSTRUCTION ERROR ESTIMATES

APPENDIX D – TIME-DISCRETE PERFORMANCE PARAMETER DEFINITIONS

APPENDIX E – TIME-DISCRETE PERFORMANCE PARAMETER DATA SETS

APPENDIX F – ANOVA MINITAB PRINTOUTS

APPENDIX G - KOHONEN SELF-ORGANISING MAP MATLAB CODE

APPENDIX H - CROSS-CORRELATION DATA SETS

APPENDIX I - VECTOR CODING DATA SETS

LIST OF FIGURES

Figure 2.1. Side-on (top) and front-on (bottom) bowling actions (adapted from ECB Fast Bowling Directives 2000). Both techniques are deemed to be safe as there is no or minimal shoulder axis counter-rotation between back foot impact and front foot impact.	11
Figure 3.1. Newell's theoretical model of interacting constraints (reproduced from Newell, 1986).	26
Figure 3.2. Basic format, structure and composition of a deterministic model (reproduced from Hay & Reid, 1988).	33
Figure 3.3. A simple deterministic or hierarchical model for cricket fast bowling. Although this model does not strictly conform to the criteria set out by Hay and Reid (1988) for constructing these performance models, it does provide an indication of the mechanical factors that are likely to be related to performance.	34
Figure 4.1. A plan view of the data collection setup (not to scale).	49
Figure 4.2. A three-dimensional view of the calibration volume (not to scale).	50
Figure 5.1. Percentage contribution of between-participant variance (σ^2_b), within-participant variance (σ^2_w) and variance from the re-digitisations (σ^2_{Ber}) to total variance for 33 time-discrete performance parameters.	63
Figure 5.2. Intra-individual movement variability (σ^2_{intra}) versus measurement error (σ^2_{error}) for 45 time-continuous variables (x, y and z for 15 anatomical landmarks).	64
Figure 6.1. A schematic showing the compression of high-dimensional input kinematics (joint angles) acquired from a cricket fast bowler between back foot impact (0%) and ball release (100%) on to a low-dimensional grid of neurons, known as a Kohonen Self-Organising Map (SOM). Owing to its non-linear properties, the abstract 2D SOM has removed redundancies in, but retained the essential topological characteristics of, the original 3D data set. The SOM displayed in this diagram is a simplified version for illustrative purposes.	68
Figure 6.2. U-matrices for participants 1 to 8.	71
Figure 7.1. Segment angular displacement definitions for: (a) upper torso and pelvis (centred mid-segment); (b) non-bowling arm and front leg (centred on proximal end of each segment); and (c) bowling arm (centred on proximal end of the segment).	78
Figure 7.2. Vector coding applied to an exemplar relative motion diagram or angle-angle plot for the UT vs. P coupling. The magnified view (a) indicates how the coupling angle (γ) was calculated at every percentage point from BFI (0%) to BR (100%). The coupling angle compass (b) shows how γ was interpreted with the hashed arrows indicating equal movement in both segments and the solid arrows indicating movement in one segment only.	80

Figure 7.3. Histograms (mean \pm SD) of the types of coordination exhibited over the 12 performance trials for the NBA vs. FL coupling during the four phases (0-24%, 25-49%, 50-74% and 75-99%) of the delivery stride for participant 1 (top left) to 8 (bottom right).	94
Figure 7.4. Histograms (mean \pm SD) of the types of coordination exhibited over the 12 performance trials for the BA vs. NBA coupling during the four phases (0-24%, 25-49%, 50-74% and 75-99%) of the delivery stride for participant 1 (top left) to 8 (bottom right).	99
Figure 7.5. Histograms (mean \pm SD) of the types of coordination exhibited over the 12 performance trials for the BA vs. FL coupling during the four phases (0-24%, 25-49%, 50-74% and 75-99%) of the delivery stride for participant 1 (top left) to 8 (bottom right).	104
Figure 7.6. Histograms (mean \pm SD) of the types of coordination exhibited over the 12 performance trials for the UT vs. P coupling during the four phases (0-24%, 25-49%, 50-74% and 75-99%) of the delivery stride for participant 1 (top left) to 8 (bottom right).	109
Figure 7.7. Histogram of statistically significant pairwise differences in cross-correlation coefficients per participant for the four segment couplings (NBA vs. FL, BA vs. NBA, BA vs. FL and UT vs. P).	112
Figure 7.8. Histogram of statistically significant pairwise differences in coupling per participant for the NBA vs. FL coupling.	114
Figure 7.9. Histogram of statistically significant pairwise differences in coupling per participant for the BA vs. NBA coupling.	114
Figure 7.10. Histogram of statistically significant pairwise differences in coupling per participant for the BA vs. FL coupling.	114
Figure 7.11. Histogram of statistically significant pairwise differences in coupling per participant for the UT vs. P coupling.	114

LIST OF TABLES

Table 4.1. Characteristics of the study sample.	47
Table 5.1. Summary mean \pm SD statistics for 5 selected performance parameters at BFI over 12 performance trials for 8 participants and 12 re-digitisations (rd) of trial 2 by participant 7. Also shown is the mean %CV across the 8 participants and %CV for the 12 re-digitisations (see Appendix D for full data sets).	60
Table 5.2. Summary mean \pm SD statistics for 8 selected performance parameters at FFF for 12 performance trials for 8 participants and 12 re-digitisations (rd) of trial 2 by participant 7. Also shown is the mean %CV across the 8 participants and %CV for the 12 re-digitisations (see Appendix D for full data sets).	60
Table 5.3. Summary mean \pm SD statistics for 5 selected performance parameters at BR for 12 performance trials for 8 participants and 12 re-digitisations (rd) of trial 2 by participant 7. Also shown is the mean %CV across the 8 participants and %CV for the 12 re-digitisations (see Appendix D for full data sets).	60
Table 5.4. Summary mean \pm SD statistics for 15 selected performance parameters at (from BFF to BR) for 12 performance trials for 8 participants and 12 re-digitisations (rd) of trial 2 by participant 7. Also shown is the mean %CV across the 8 participants and %CV for the 12 re-digitisations (see Appendix D for full data sets).	61
Table 7.1. Types of coordination and their coupling angle (γ) boundaries.	81
Table 7.2. Mean and SD ball release speeds calculated across the 12 deliveries bowled by each of the 8 participants.	85
Table 7.3. Games-Howell's <i>post hoc</i> test results for average ball release speed by participant.	85
Table 7.4. Mean (SD) phase-lagged cross-correlation coefficients calculated over the 12 performance trials performed by each of the 8 participants.	86
Table 7.5. Mean (SD) phase-lagged Z-transformed cross-correlation coefficients calculated over the 12 performance trials performed by each of the 8 participants.	86
Table 7.6. Games-Howell's <i>post hoc</i> test results for mean phase-lagged Z-transformed cross-correlation coefficients (NBA vs. FL coupling) by participant.	88
Table 7.7. Games-Howell's <i>post hoc</i> test results for mean phase-lagged Z-transformed cross-correlation coefficients (BA vs. NBA coupling) by participant.	88
Table 7.8. Tukey's <i>post hoc</i> test results for mean phase-lagged Z-transformed cross-correlation coefficients (BA vs. FL coupling) by participant.	88

Table 7.9. Tukey’s <i>post hoc</i> test results for mean phase-lagged Z-transformed cross-correlation coefficients (UT vs. P coupling) by participant.	89
Table 7.10. Pearson product-moment correlation coefficients for: (i) peak phase-lagged Z-transformed cross-correlation coefficients and ball release speed for each participant; (ii) the average peak phase-lagged Z-transformed cross-correlation coefficient calculated across the 12 deliveries for each participant and average ball release speed; and (iii) peak phase-lagged Z-transformed cross-correlation coefficient for the best performing trial and corresponding ball release speed for each participant.	89
Table 7.11. Average mean (SD) coupling angle calculated during the 4 phases (0-24%, 25-49%, 50-74% and 75-99%) of the delivery stride over 12 performance trials for the NBA vs. FL coupling.	90
Table 7.12. Games-Howell’s <i>post hoc</i> test results for average mean coupling angle for the NBA vs. FL coupling (0-24%) by participant.	92
Table 7.13. Games-Howell’s <i>post hoc</i> test results for average mean coupling angle for the NBA vs. FL coupling (24-49%) by participant.	92
Table 7.14. Games-Howell’s <i>post hoc</i> test results for average mean coupling angle for the NBA vs. FL coupling (50-74%) by participant.	92
Table 7.15. Games-Howell’s <i>post hoc</i> test results for average mean coupling angle for the NBA vs. FL coupling (75-99%) by participant.	93
Table 7.16. Pearson product-moment correlation coefficients for: (i) mean coupling angle for the NBA vs. FL coupling and ball release speed for each participant; (ii) the average mean coupling angle for the NBA vs. FL coupling calculated across the 12 deliveries for each participant and average ball release speed; and (iii) mean coupling angle for the NBA vs. FL coupling for the best performing trial and corresponding ball release speed for each participant.	93
Table 7.17. Average mean (SD) coupling angle calculated during the 4 phases (0-24%, 25-49%, 50-74% and 75-99%) of the delivery stride over 12 performance trials for the BA vs. NBA coupling.	95
Table 7.18. Games-Howell’s <i>post hoc</i> test results for average mean coupling angle for the BA vs. NBA coupling (0-24%) by participant.	97
Table 7.19. Tukey’s <i>post hoc</i> test results for average mean coupling angle for the BA vs. NBA coupling (25-49%) by participant.	97
Table 7.20. Tukey’s <i>post hoc</i> test results for average mean coupling angle for the BA vs. NBA coupling (50-74%) by participant.	97
Table 7.21. Games-Howell’s <i>post hoc</i> test results for average mean coupling angle for the BA vs. NBA coupling (75-99%) by participant.	98
Table 7.22. Pearson product-moment correlation coefficients for: (i) mean coupling angle for the BA vs. NBA coupling and ball release speed for each participant; (ii) the average mean coupling angle for the BA vs. NBA coupling	

calculated across the 12 deliveries for each participant and average ball release speed; and (iii) mean coupling angle for the BA vs. NBA coupling for the best performing trial and corresponding ball release speed for each participant.	98
Table 7.23. Average mean (SD) coupling angle calculated during the 4 phases (0-24%, 25-49%, 50-74% and 75-99%) of the delivery stride over 12 performance trials for the BA vs. FL coupling.	100
Table 7.24. Tukey's <i>post hoc</i> test results for average mean coupling angle for the BA vs. FL coupling (0-24%) by participant.	102
Table 7.25. Tukey's <i>post hoc</i> test results for average mean coupling angle for the BA vs. FL coupling (25-49%) by participant.	102
Table 7.26. Games-Howell's <i>post hoc</i> test results for average mean coupling angle for the BA vs. FL coupling (50-74%) by participant.	102
Table 7.27. Games-Howell's <i>post hoc</i> test results for average mean coupling angle for the BA vs. FL coupling (75-99%) by participant.	103
Table 7.28. Pearson product-moment correlation coefficients for: (i) mean coupling angle for the BA vs. FL coupling and ball release speed for each participant; (ii) the average mean coupling angle for the BA vs. FL coupling calculated across the 12 deliveries for each participant and average ball release speed; and (iii) mean coupling angle for the BA vs. FL coupling for the best performing trial and corresponding ball release speed for each participant.	103
Table 7.29. Average mean (SD) coupling angle calculated during the 4 phases (0-24%, 25-49%, 50-74% and 75-99%) of the delivery stride over 12 performance trials for the UT vs. P coupling.	105
Table 7.30. Tukey's <i>post hoc</i> test results for average mean coupling angle for the UT vs. P coupling (0-24%) by participant.	107
Table 7.31. Games-Howell's <i>post hoc</i> test results for average mean coupling angle for the UT vs. P coupling (25-49%) by participant.	107
Table 7.32. Tukey's <i>post hoc</i> test results for average mean coupling angle for the UT vs. P coupling (50-74%) by participant.	107
Table 7.33. Games-Howell's <i>post hoc</i> test results for average mean coupling angle for the UT vs. P coupling (75-99%) by participant.	108
Table 7.34. Pearson product-moment correlation coefficients for: (i) mean coupling angle for the UT vs. P coupling and ball release speed for each participant; (ii) the average mean coupling angle for the UT vs. P coupling calculated across the 12 deliveries for each participant and average ball release speed; and (iii) mean coupling angle for the UT vs. P coupling for the best performing trial and corresponding ball release speed for each participant.	108

Chapter I
Introduction

1.0 Historical Background

Sport and exercise science is often considered to be a relatively new field of study. Indeed, higher education institutions around the world have only been offering undergraduate degrees in this discipline since the 1960s. In reality, however, scholarly investigations into sport and exercise have been going on for at least the last 2,500 years. It could be argued that two of the first sport and exercise scientists were Hippocrates (c. 460-370 B.C.) and Galen (c. A.D. 129-216). The former was interested in the prophylactic and therapeutic benefits of exercise and was involved in the training of athletes who competed in the ancient Olympic Games, and the latter, who is regarded by some (e.g., Snook, 1978) as the father of the related field of sports medicine, was appointed by Emperor Marcus Aurelius to provide surgical and medical support to the gladiators and assist with the planning of nutritional and training programmes (Porter, 1999).

Although the methods and technologies used in the delivery of sport science support to professional athletes are obviously far more advanced these days, the composition and structure of contemporary sport science support is, in many ways, similar to that provided during the Hellenic and Roman periods. Now, top athletes and professional sports teams in most developed countries around the world have access to state-funded elite sports academies and centres of excellence, and are supported by multidisciplinary teams of sport scientists who routinely implement strategically-designed support programmes to help boost performance and reduce injury risk. Cricket, in particular, has benefited greatly from this support structure and provision. One of the reasons touted for the success of the great Australian teams of the past two decades was the creation of the Australian Cricket Academy in 1987, which was developed through a joint initiative between the Australian Institute of Sport and the Australian Cricket Board. Similarly, the National Performance Centre in the UK, formerly the National Cricket Academy, has been identified as one of the reasons behind the current success of the England cricket team.

1.1 Focus of this Thesis

The fast bowler is widely regarded to be one of the most important members of a cricket team and potentially one of the most influential in determining the outcome of a match. However, they have also shown to be at the greatest risk of injury (e.g., Stretch, 2003), with their lower back being most susceptible to both traumatic and overuse injury (e.g.,

Weatherley, Hardcastle, Foster & Elliott, 1996), forcing them to endure more time away from the game than any other category of player (e.g., Orchard, James, Alcott, Carter & Farhart, 2002). The realisation of these factors has led to the formation of specialist fast bowling academies in various countries around the world (e.g., the MRF Pace Foundation in Chennai) to promote and encourage the use of safe and effective fast bowling techniques among aspiring young fast bowlers. Most Test-playing nations now also employ the services of a full-time fast bowling coach to assist in refining the techniques and enhancing tactical awareness of fast bowlers who are being introduced to the international game at an increasingly younger age.

Despite the increased interest in fast bowling from a coaching perspective, scientific research into this important facet of the game has been much slower to develop. Since the pioneering investigations into the biomechanics of fast bowling techniques by researchers at the University of Western Australia approximately a quarter of a century ago (e.g., Elliott & Foster, 1984; Foster, John, Elliott, Ackland & Fitch, 1989; Elliott, Hardcastle, Burnett & Foster, 1992), progress has been limited to a relatively small, but steadily increasing, number of studies published in academic journals. Many of these investigations have attempted to build upon the research by Elliott and colleagues and establish causative associations between bowling technique and lower back injuries (e.g., Burnett, Elliott, & Marshall, 1995; Burnett, Barrett, Marshall, Elliott & Day, 1998; Portus, Mason, Elliott, Pfitzner & Done, 2004). Indeed, recent research has indicated that a combination of contralateral side flexion and ipsilateral axial rotation of the lumbar spine, not counter-rotation of the shoulder axis as previously thought, is likely to be instrumental in the development of abnormal radiological features, such as spondylolysis, spondylolisthesis, pedicle sclerosis and intervertebral disc degeneration (e.g., Ranson, Burnett, King, Patel & O'Sullivan, 2008; Glazier, 2010b; Stuelcken, Ferdinands, & Sinclair, 2010).

There have been even fewer scientific studies focusing on the factors that contribute to proficient fast bowling performance. Although many of the investigations published in the literature have provided some useful insights into the biomechanical factors that contribute to a high ball release speed and bowling accuracy (e.g., Glazier, Paradisis & Cooper, 2000; Portus, Sinclair, Burke, Moore & Farhart, 2000; Loram, McKinon, Wormgoor, Rogers, Nowak & Harden, 2005; Salter, Sinclair & Portus, 2007; Wormgoor, Harden & McKinon, 2008), it could be argued that they have generally failed to make a substantive contribution to the enhancement of knowledge. In many

respects, these investigations have suffered from the same issues that have plagued performance-oriented sports biomechanics research, more generally, for the past three decades—that is, they have generally failed to move beyond the descriptive phase to a more analytical one, they have typically not made reference to motor control theory, the universal principles of biomechanics, or the fundamental laws of physics and biology that govern them, and they have tended to be product-driven rather than process-driven (e.g., Baumann, 1987; Norman, 1989; Zatsiorsky & Fortney, 1993; Bartlett, 1997). The recent emergence of dynamical systems theory in human movement science, however, appears to hold much promise, not only in resolving some of the issues inhibiting progress in research on fast bowling performance, but for applied sports biomechanics research more generally (see Glazier, Davids & Bartlett, 2003; Glazier, Wheat, Pease & Bartlett, 2006; Davids & Glazier, 2010). The focus of this thesis is, therefore, on the application of dynamical systems theory and its associated ‘complex’¹ analyses to enhancing knowledge on fast bowling performance and its wider application to performance-oriented sports biomechanics research.

1.2 Research Question

Can dynamical systems theory and ‘complex’ analyses be used to help understand the biomechanical and motor control processes underpinning proficient fast bowling performance?

1.3 Aims and Objectives

This thesis has two aims:

- (i) to enhance understanding of the biomechanical and motor control processes that underpin proficient fast bowling performance using dynamical systems theory and ‘complex’ analyses;
- (ii) to demonstrate the application of dynamical systems theory and the utility of ‘complex’ analyses to performance-oriented sports biomechanics research, more generally, using cricket fast bowling as a representative task vehicle.

¹ Following Hamill, Haddad and van Emmerik (2006), ‘complex’ is used here to collectively describe analytical techniques that enable the interaction of two or more joints or segments to be analysed as opposed to ‘simple’ analytical techniques that allow only a single joint or segment to be analysed in isolation.

To successfully meet these aims, the following objectives will be fulfilled:

- (i) Provide a detailed theoretical analysis of how dynamical systems theory can be applied to integrate the sub-disciplines of biomechanics and motor control, and enhance performance-oriented sport biomechanics research
- (ii) Establish whether manual coordinate digitising can reliably measure differences in time-discrete and time-continuous measurements both within and between bowlers.
- (iii) Use Kohonen Self-Organisation Maps (SOMs) to measure differences in coordination between bowlers at a whole-body, global level of analysis and establish whether a ‘common optimal movement pattern’ exists
- (iv) Apply various ‘complex’ analyses (i.e., cross-correlation and vector coding) in a multiple single-participant design to analyse intersegmental coordination of upper and lower extremity during delivery and establish any relationships with ball release speed.

1.4 Structure of this Thesis

The remainder of this thesis is comprised of the following chapters:

Chapter II critically reviews and summarises the main empirical studies published on fast bowling performance, specifically ball release speed. Key findings from these investigations, along with any inherent limitations, are highlighted. It is concluded that, for substantive progress to be made in understanding the processes of coordination and control underpinning proficient fast bowling performance, the reductionist, nomothetic (inter-individual), product-oriented approach typically used in sports biomechanics research needs to be superseded by a holistic, idiographic (intra-individual), process-oriented approach in conjunction with an appropriate theoretical framework. Dynamical systems theory is identified as being one such theoretical framework that appears to be particularly well-suited to this research endeavour.

Chapter III provides a theoretical development of the biomechanics-motor control nexus. It begins with an overview of key concepts from dynamical systems theory, such as self-organisation and constraints, and how they relate to the formation of what Turvey (1990, p. 940) described as the “... most primitive independently governable actuator of movements”—the coordinative structure or functional motor synergy. The ramifications for sports biomechanics of conceptualising the human

movement system as a complex, non-linear neurobiological system (dynamical systems perspective) rather than a deterministic, information-driven machine finitely controlled by a capacity-limited microcomputer acting as the brain (information processing perspective) are discussed, specifically the implications for: hypothesis generation (Davids & Glazier, 2010); research design (Glazier *et al.*, 2003); experimentation (Glazier *et al.*, 2006); inverse dynamics analyses (Glazier & Davids, 2009a); forward dynamics analyses (Glazier & Davids, 2009b); the use of ‘complex’ analyses (Glazier *et al.*, 2003; Wheat & Glazier, 2006); and interpretations of movement variability (Glazier *et al.*, 2006). To conclude, a case is made for not moving beyond the kinematic level of analysis based on the theoretical arguments presented in this chapter.

Chapter IV provides a detailed account of the methods used to acquire and condition the kinematic data used in the empirical studies described in Chapters V, VI and VII. The characteristics of the study sample, and the experimental protocol, data collection, data reconstruction and data processing procedures adopted during, and subsequent to, this session are outlined in this chapter. These procedures are justified with recourse to existing technical notes and methodological papers published previously in the biomechanics literature.

Chapter V assesses the suitability of manual coordinate digitising for analysing intra- and inter-individual movement variability. Generally speaking, experimental errors and their consequences have not been well-evaluated in applied biomechanical research studies. Indeed, Bartlett, Stockill, Elliott and Burnett (1996) argued that future kinematic studies of fast bowling techniques need to evaluate experimental errors much more rigorously than in previous investigations. Recently, there has been some conjecture in the literature about the suitability of manual coordinate digitising for analysing movement variability (see Bartlett, Bussey & Flyger, 2006). Given the need for sports biomechanists analysing cricket fast bowling techniques to be able to reliably measure differences within and between bowlers at specific instances during, and throughout the course of, the delivery stride, both the reliability of time-discrete and time-continuous kinematic measurements is considered.

Chapter VI examines the application of SOMs to the analysis of cricket fast bowling techniques. Although they have been frequently used in biomechanical analyses of gait, SOMs have been used only sparingly in kinematic analyses of sports techniques and have yet to be applied to cricket fast bowling. In this chapter, differences

in the topology² of fast bowling techniques between bowlers are analysed and a theoretical argument against the ‘common optimal movement pattern’ or ‘idealised motor template’ concept (Brisson & Alain, 1996) is constructed. The origins of these topological differences are discussed and the utility and practical application of SOMs to performance-oriented sports biomechanics research, more generally, is considered.

Chapter VII examines the relationship between intersegmental coordination and ball release speed in cricket fast bowling. Whereas Chapter VI analysed coordination at a whole-body global level, this chapter considers coordination at a more local level using several different ‘complex’ analytical techniques (i.e., cross-correlation functions and vector coding) derived from dynamical systems theory. It has previously been suggested that coupling relationships between the bowling arm and the non-bowling arm, the non-bowling arm and the front leg, and the bowling arm and the front leg might be related to ball release speed (Davis & Blanksby, 1976b; Lillee, 1977; Pont, 2006), but as of yet, these associations have not been empirically-verified. A multiple single-participant research design was adopted to enable coordination strategies that were individual-specific and those that were generalisable to the group to be identified.

Chapter VIII summarises the main empirical findings to emerge from Chapters V, VI and VII and discusses the practical implications for fast bowling coaching and talent identification. The potential contribution of adopting a dynamical systems theoretical approach to performance-oriented sports biomechanics research and other related areas of sports science, such as the emerging sub-discipline of performance analysis (Glazier, 2010a), are also highlighted. To conclude, several recommendations for future research are made.

² Bernstein (1967) used the term ‘topology’ to refer to the “... whole of qualitative characteristics of space configurations and of the form of movements in contrast to the quantitative, metric ones” (p. 42).

Chapter II

Review of the Literature:

Biomechanics of Fast Bowling Performance

2.0 Introduction

In Chapter I, it was noted that there has been a relative paucity of scientific investigations into the factors that underpin proficient fast bowling performance (i.e., ball release speed and accuracy) (Bartlett *et al.*, 1996; Bartlett, 2003). Much of the early research on fast bowling performance was based on the observation and expert evaluation of ciné film footage (e.g., Penrose, Foster & Blanksby, 1976; Davis & Blanksby, 1976a,b) and descriptive kinematic and force platform analyses (e.g., Elliott & Foster, 1984; Elliott, Foster & Gray, 1986; Mason, Weissenteiner & Spence, 1989) of successful fast bowlers. Latterly, surface electromyography was used to determine the sequential and temporal patterning of muscle activity in collegiate fast-medium bowlers (e.g., Burden & Bartlett, 1991). Subsequent empirical studies attempted to establish statistical associations among kinematic variables, anthropometric parameters, physical capacities and ball release speed (e.g., Burden & Bartlett, 1990a,b; Stockill & Bartlett, 1992a; Glazier *et al.*, 2000; Portus *et al.*, 2004; Loram *et al.*, 2005; Salter *et al.*, 2007). More recently, inverse dynamics analyses (e.g., Ferdinands, Marshall, Round & Broughan, 2003; Ferdinands & Marshall, 2004) and forward dynamics simulations (e.g., Ferdinands, Broughan & Round, 2002) have been used to examine forces and torques that contribute to the generation of ball release speed.

There have been far fewer studies that have focused on bowling accuracy. Devlin, Fraser, Barras and Hawley (2001) reported that moderate exercise-induced hypohydration impaired bowling accuracy but not ball release speed in sub-elite standard fast-medium cricket bowlers. Taliep, Gray, St Clair Gibson, Calder, Lambert and Noakes (2003) found that there was no change in bowling accuracy over the course of a 12-over bowling spell but there was a decrease in ball release speed, particularly after the 6th over. Petersen, Wilson and Hopkins (2004) showed that training with overweight and underweight cricket balls over a 10-week period decreased bowling accuracy but only slightly increased ball release speed. Duffield, Carney and Karppinen (2009) indicated no decrease in ball release speed or bowling accuracy during two 6-over bowling spells interspersed by a 45-minute period of light physical activity. Phillips, Portus, Davids and Renshaw (2012) revealed that national and emerging fast bowlers were better able to bowl to different targets, with greater consistency, and at greater speeds than junior fast bowlers. None of these studies, however, analysed the movement dynamics responsible for producing these outcomes or how different task (e.g., different weighted balls) and organismic constraints (e.g., fatigue) might have

influenced those movement dynamics. To date, only one biomechanical study by Portus *et al.* (2000) has attempted to link bowling accuracy and technique but, as discussed below, this investigation was not without limitation.

In the following sections, key empirical studies examining the biomechanical factors associated with a high ball release speed (section 2.1) and bowling accuracy (section 2.2) are reviewed and the key findings to emerge from these investigations are highlighted along with any deficiencies in the methods used.

2.1 Biomechanical Factors Associated with Ball Release Speed

In the first documented account of fast bowling to appear in a scientific journal, Penrose *et al.* (1976) used high-speed cinematography to calculate and compare ball release speeds among international fast bowlers in the test match between Australia and the West Indies at the W.A.C.A. Ground, Perth on 12-16 December, 1975. It was reported that Jeff Thomson, Andy Roberts, Michael Holding, Dennis Lillee, Keith Boyce and Gary Gilmore released the ball at $44.3 \text{ m}\cdot\text{s}^{-1}$, $41.6 \text{ m}\cdot\text{s}^{-1}$, $41.0 \text{ m}\cdot\text{s}^{-1}$, $38.4 \text{ m}\cdot\text{s}^{-1}$, $37.9 \text{ m}\cdot\text{s}^{-1}$ and $37.0 \text{ m}\cdot\text{s}^{-1}$ respectively, and that the ball tended to decelerate 15.5 percent by the time it reached the batsman at the opposite end of the pitch. Penrose *et al.* (1976) also noted marked differences in the run-up speeds and technique styles of the world-class express fast bowlers in the sample. Thomson's approach run peaked at $5.0 \text{ m}\cdot\text{s}^{-1}$, which was considerably slower than Lillee, Roberts and Holding, who peaked at $9.3 \text{ m}\cdot\text{s}^{-1}$, $8.0 \text{ m}\cdot\text{s}^{-1}$ and $7.8 \text{ m}\cdot\text{s}^{-1}$, respectively. Thomson's slower run-up speed enabled him to adopt a more side-on position at back foot impact with more backward body lean than the other three bowlers. Thomson then pivoted over a straight front leg, as did Holding, enabling them both to release the ball from a greater height than Lillee and, more noticeably, Roberts who tended to collapse their front knees during delivery. Given the apparent performance benefits afforded by Thomson's javelin-style technique, Penrose *et al.* (1976) conjectured whether his idiosyncratic style might become 'the' fast bowling action of the future or whether it would remain unique to him.

Davis and Blanksby (1976a) tested 17 proficient bowlers from cricket clubs in Western Australia with the aim of establishing the respective contribution of different body segments to ball release speed. Each bowler was asked to deliver the ball under five experimental conditions: (i) from a standing position with their weight initially on their back foot before transferring laterally to their front foot; (ii) from the same standing position but with a restraint on the wrist of the bowling hand to prevent wrist

flexion and extension; (iii) from an upright position with a restraint on the legs and hips to prevent hip rotation and extension and leg action; (iv) from the same upright position but with an additional restraint on the chest to prevent all movement except for arm action; and (v), normally without restraint from a full run-up. A high-speed ciné camera operating at 100 Hz was used to calculate ball release speeds for the different conditions. Davis and Blanksby (1976a) calculated the run-up to contribute 19% to the release speed, leg action and hip rotation 23%, trunk flexion and shoulder girdle rotation 11%, arm action 42% and hand flexion 5%. These findings, however, need to be treated with caution since the joint immobilization or restraint paradigm adopted presupposes that the restriction of one or more joints will not alter the coordinated action of the unaffected body segments, which is, at best, a tenuous assumption (Miller, 1980).

In a follow-up study, Davis and Blanksby (1976b) compared the bowling techniques of the six fastest bowlers (fast group) with the six slowest bowlers (slow group) from the sample of 17 that featured in their previous study. They reported only a marginal difference between the two groups in the length and angle of the run-up with the fast group having a run-up some two metres longer than the slow group. Both groups decelerated sharply during the final stride of the run-up, thus facilitating a change of body orientation to a more side-on position during the pre-delivery stride. However, the fast group were found to be more side-on at back foot impact and the four fastest bowlers all looked over the lateral aspect of their front arm whereas the three slowest bowlers looked inside the medial aspect. During the delivery stride, the fast group tended to adduct their front more abruptly and further in towards their ribs than the slow group. In contrast, the slow group brought their front foot down faster than those in the fast group. The front leg in the fast group was found to be 15% straighter at the point of delivery than in the slow group and wrist flexion was far greater and occurred closer to the instant of release in the fast group. There was no difference between groups for the range of trunk motion in the sagittal plane between back foot impact and ball release. However, the range of motion of the shoulder axis between back foot impact and ball release in the transverse plane was greater in the fast group. Finally, the alignment of the delivery stride was similar between groups with 67% of all bowlers directing their front foot towards the target.

Elliott and Foster (1984) provided the first full biomechanical analysis of the fast bowling action. The aim of this investigation was to compare the kinematics and kinetics of side-on and front-on fast bowling techniques (see Figure 2.1). The study

sample consisted of four Australian international fast bowlers: Jeff Thomson, Terry Alderman, Geoff Lawson and Ian Callen. Each bowler was required to bowl three maximum effort deliveries with their normal action, three maximum effort deliveries using a more side-on action and three maximum effort deliveries using a front-on action. Two high-speed ciné cameras were situated laterally (200 Hz) and overhead (100 Hz) to film each delivery for subsequent digitisation and a force platform was situated at the location of front foot impact to collect ground reaction force data. A simple linear scaling procedure was used to generate two-dimensional displacement data for joint centres in the link segment system. These data were then smoothed and differentiated to obtain velocity and acceleration data. As Alderman was the only bowler capable of altering his bowling action, only the kinematics and kinetics of his side-on and front-on techniques and the normal techniques of the other bowlers were reported. This study showed that run-up speeds of bowlers using a side-on action were less than those using a front-on action (3.9 m.s^{-1} vs. 4.5 m.s^{-1}). Interestingly, these data are substantially lower than those reported by Penrose *et al.* (1976) for other international fast bowlers indicating methodological problems in that study. Also, the peak vertical velocity of the elbow of the non-bowling arm in bowlers using a side-on action was greater than in those using a front-on action (-3.2 m.s^{-1} vs. -2.4 m.s^{-1}). This study did not produce any evidence to suggest that the side-on action is superior to the front-on action in terms of having the potential to generate greater ball release speed. However, it was concluded that the side-on action might be a more effective method of generating a high ball release speed as side-on bowlers can run-up slower, make better use of their non-bowling arm, and can more precisely time hip and shoulder rotations, resulting in a more effective summation of body forces while minimising stress imposed on body segments and joints.

Elliott *et al.* (1986) used an identical experimental setup to collect kinematic and kinetic data from 15 Western Australia first-grade or international fast-medium ($30.6 \pm 2.0 \text{ m.s}^{-1}$) bowlers. This investigation showed that the bowlers analysed tended to adopt an open shoulder alignment at back foot impact ($231.8 \pm 17.6^\circ$), which the authors suggested might have restricted the maximum ball release speed because the effective ranges of hip and shoulder rotations are reduced with this type of bowling action. Similar to Davis and Blanksby (1976a), Elliott *et al.* (1986) also attempted to quantify the contributions of different body segments to ball release speed. However, instead of attempting to immobilise limb and torso segments with restraints, Elliott *et al.* (1986)

SIDE-ON ACTION

Side view

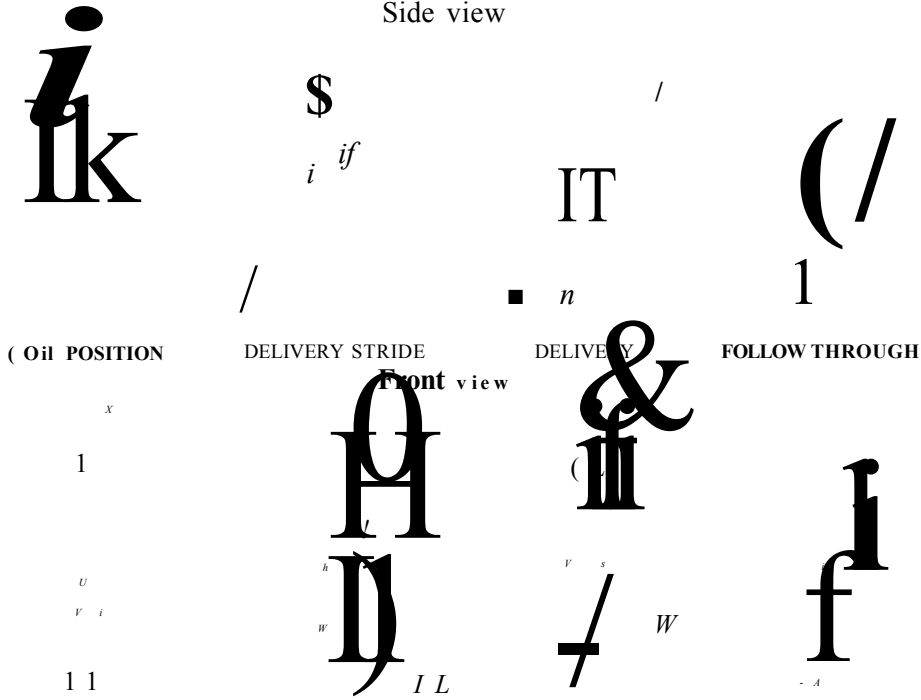

FRONT-ON ACTION

Side view

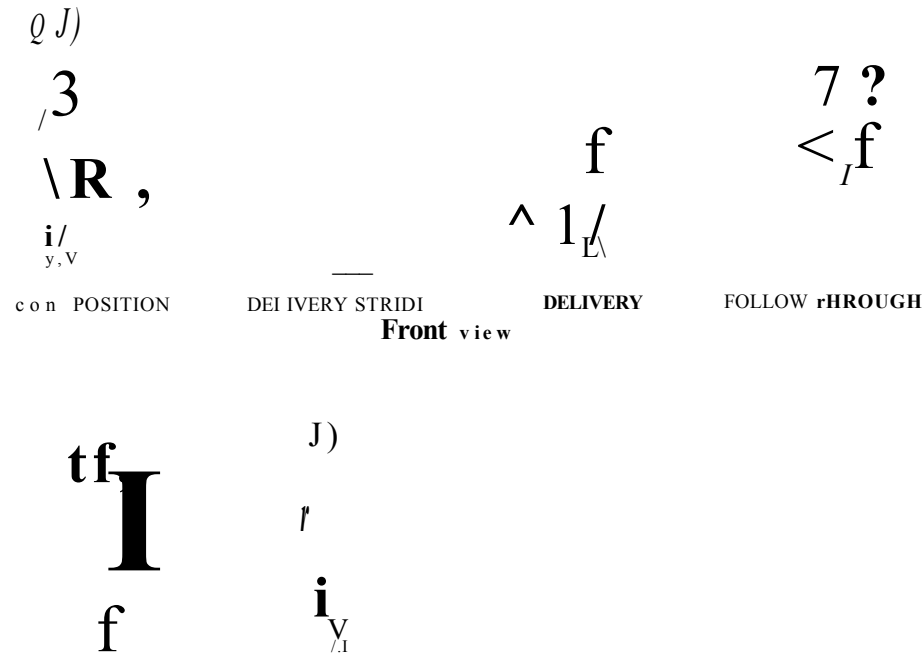

Figure 2.1. Side-on (top) and front-on (bottom) bowling actions (adapted from ECB Fast Bowling Directives 2000). Both techniques are deemed to be safe as there is no or minimal shoulder axis counter-rotation or realignment to a more side-on position between back foot impact and front foot impact.

simply calculated the difference between peak resultant velocities of adjacent joint centres in the link segment system and expressed this difference as a percentage of the ball release speed. They calculated that the run-up and hip action contributed 15% of ball release speed, shoulder action 13%, arm action 50%, and hand and finger action 22%. These results contrast markedly to those reported by Davis and Blanksby (1976b). For example, the run-up and hip action combined in that study contributed 42% of ball release speed, 27% more than calculated by Elliott *et al.* (1986). Furthermore, Davis and Blanksby (1976a) calculated the total arm action contributed 47% of ball release speed, whereas Elliott *et al.* (1986) calculated it to contribute 72% of ball release speed. The reason for these discrepancies in percentage contributions is unclear although it is likely to be an artefact of the method of calculation.

A further descriptive biomechanical study was undertaken by Mason *et al.* (1989) to develop an 'optimal' model of the bowling technique (i.e., one that maximises ball release speed but minimises the likelihood of injury), which was to be used as a basis for teaching young fast bowlers. Fifteen fast-medium bowlers ($\bar{x} = 32.4 \text{ m.s}^{-1}$) from the Australian Institute of Sport Cricket Academy were filmed from the front and side using two phase-locked high-speed (100 Hz) ciné cameras. A force platform measured ground reaction forces at front foot impact, a series of light gates positioned four metres apart down the length of the bowler's run-up was used to determine horizontal speed during different intervals of the run-up and a radar gun was used to measure ball release speed. The trial performed by each bowler yielding the highest release speed was selected for analysis. The results of this study indicated that 14 of the bowlers analysed adopted side-on actions and only one bowler adopted a front-on action. Although the exact classification criteria were not disclosed, this finding seemed to contradict the previously reported results of Elliott *et al.* (1986) indicating that fast bowling techniques were increasingly becoming more front-on. The mean run-up speed during the 16-12 metre, 12-8 metre, 8-4 metre and 4-0 metre intervals before the popping crease was 6.1 m.s^{-1} , 6.1 m.s^{-1} , 5.7 m.s^{-1} and 5.6 m.s^{-1} , respectively, indicating a slight decrease in speed as bowlers prepared to deliver the ball. Mason *et al.* (1989) emphasised several technical characteristics (angles, orientations and rotations of joints and body segments) at arbitrary instances during the delivery stride (initiation of hip rotation, front foot impact, peak ground reaction force and ball release) that they thought were important in proficient fast bowling but did not elaborate on how these related to ball release speed. In fact, hardly any kinematic data about specific elements

of the bowling action were reported with the authors relying almost exclusively on subjective evaluation of stick-figure animations as the basis for their analysis.

In the first of a series of papers to emerge from the National Cricket Association Sport Science Support Programme 'Fast Bowling Project', Burden and Bartlett (1990a) reported the results of a kinematic investigation of 17 international and county fast ($> 36 \text{ m}\cdot\text{s}^{-1}$) and fast-medium ($< 36 \text{ m}\cdot\text{s}^{-1}$) bowlers, including Patrick Patterson, Graham Dilley and Ian Botham. A high-speed ciné camera, operating at 200 Hz and situated laterally on the boundary edge along the line of the popping crease, was used to record 6 deliveries from each bowler during 6 county championship matches of the 1989 season. The fastest delivery bowled by each of the bowlers was selected for two-dimensional kinematic analysis. This study reported a low correlation between run-up speed and ball release speed ($r = 0.21$, $P > 0.05$), although, curiously, run-up speed appeared to be measured at the point of ball release, not at back foot impact as is customary, which is likely to account for some of the unusually low run-up speeds reported. A moderate correlation ($r = 0.41$, $P > 0.05$) was also shown to exist between front knee angle at ball release and ball release speed, although those bowlers who flexed their front knee between front foot impact and ball release were shown to have a lower ball release speed. This study was notable because it was the first to attempt to establish formal associations between aspects of technique and ball release speed via the application of inferential statistical analyses. It was also the first scientific study on fast bowling to move beyond description and make explicit reference to key underpinning biomechanical principles (i.e., the kinematic chain).

In a follow-up study, Burden and Bartlett (1990b) compared the kinematics of nine collegiate fast-medium bowlers with the kinematics of the seven elite fast bowlers who featured in their previous study. The results of this study indicated that the faster ball release speeds of elite fast bowlers compared with those of the collegiate fast-medium bowlers ($37.0 \pm 1.0 \text{ m}\cdot\text{s}^{-1}$ vs. $28.2 \pm 1.1 \text{ m}\cdot\text{s}^{-1}$) could be attributed to the slightly higher run-up speeds of the former than the latter ($5.5 \pm 0.5 \text{ m}\cdot\text{s}^{-1}$ vs. $4.8 \pm 0.7 \text{ m}\cdot\text{s}^{-1}$) and the progressively greater differences in peak linear speed of joint centres comprising the kinematic chain (hip: $6.1 \pm 0.5 \text{ m}\cdot\text{s}^{-1}$ vs. $5.4 \pm 0.8 \text{ m}\cdot\text{s}^{-1}$; shoulder: $9.6 \pm 0.6 \text{ m}\cdot\text{s}^{-1}$ vs. $8.1 \pm 0.4 \text{ m}\cdot\text{s}^{-1}$; wrist: $24.5 \pm 0.8 \text{ m}\cdot\text{s}^{-1}$ vs. $20.9 \pm 1.0 \text{ m}\cdot\text{s}^{-1}$; middle knuckle: $27.3 \pm 0.8 \text{ m}\cdot\text{s}^{-1}$ vs. $23.4 \pm 1.2 \text{ m}\cdot\text{s}^{-1}$). The higher angular velocity of the bowling arm in the elite fast bowlers compared with those of the collegiate fast-medium bowlers ($29.7 \text{ rad}\cdot\text{s}^{-1}$ vs. $26.6 \text{ rad}\cdot\text{s}^{-1}$) was suggested to be primarily responsible for the greater increase

in peak linear speed of the wrist joint compared to the shoulder joint in the elite group compared to the collegiate group. A rapid flexion of the fingers closer to the moment of ball release was also hypothesised to account for the greater increase in peak linear speed of the ball release speed compared to the middle knuckle in the elite group compared to the collegiate group. Perhaps the most distinct difference between the two groups was the action of the front knee. The elite fast bowlers hardly flexed their front leg during the phase between front foot impact and ball release, whereas the front knee of the collegiate fast-medium bowlers underwent a period of flexion and generally failed to extend again before ball release.

Building on the project's earlier two-dimensional studies, Stockill and Bartlett (1992a) performed the first three-dimensional kinematic analysis of fast bowling techniques. The participants in this study were 17 first-class and international fast ($> 35.8 \text{ m.s}^{-1}$) and fast-medium ($< 35.8 \text{ m.s}^{-1}$) bowlers, including Curtly Ambrose, Allan Donald and Waqar Younis. Two high-speed ciné cameras operating at 200 Hz situated laterally and behind the bowler were used to collect film footage of deliveries bowled during test matches, county championship fixtures and net sessions of the 1991 season. The footage was subsequently digitised and reconstructed using a direct linear transformation algorithm to convert two-dimensional image-coordinates to three-dimensional object-space coordinates. Although the results of this study tended to focus on alignments of the back foot, hip axis and shoulder axis at key instances during delivery with less emphasis on the biomechanical factors related to ball release speed, Stockill and Bartlett (1992a) reported a positive correlation ($r = 0.55, P < 0.05$) between run-up speed and ball release speed. However, as the unusually high average run-up speed ($6.8 \pm 1.7 \text{ m.s}^{-1}$) might be attributable to extrapolation errors associated with reconstruction points lying beyond of the calibration volume, the authors advised caution when interpreting these results. In another write-up of this study that appeared in the 'Cricket Coach', the journal of the Association of Cricket Coaches, Stockill and Bartlett (1992b) noted the degree of front knee flexion at ball release was inversely related to ball release speed. Although no data were provided, it was reported that faster bowlers tended to have a more extended or, in some cases, hyperextended front knees at ball release.

In a follow-up study, Stockill and Bartlett (1994) compared the kinematic and temporal characteristics of junior and senior fast bowling actions to establish the most important technique parameters associated with producing a high ball release speed.

Two phase-locked ciné cameras operating at 100 Hz, and two gen-locked video cameras operating at 50 Hz, were used to capture movement sequences for 12 fast senior international bowlers and 12 fast-medium junior international bowlers, respectively. The footage was subsequently digitised and reconstructed using a direct linear transformation algorithm to convert two-dimensional image-coordinates to three-dimensional object-space coordinates. The results of this study showed that the ball release speeds of senior international fast bowlers were greater than junior international fast bowlers ($38.1 \pm 1.4 \text{ m.s}^{-1}$ vs. $32.1 \pm 1.9 \text{ m.s}^{-1}$) as were the peak linear speeds of the right hip, seventh cervical vertebra, right shoulder, right wrist and right middle knuckle. Furthermore, the timings of these peak linear speeds occurred closer to ball release for seniors than the juniors. However, when these timings were expressed as a percentage of delivery stride duration, these temporal differences disappeared. Stockill and Bartlett (1994) concluded that differences in ball release speed might be attributable to higher run-up speeds, slightly higher angular velocities for the trunk and bowling arm and greater upper limb lengths, as it was argued that the longer bowling arm lengths of the seniors will produce higher ball speeds for a given angular velocity.

To investigate the influence of kinematic and anthropometric variables on ball release speed, Glazier *et al.* (2000) performed a three-dimensional kinematic analysis on nine collegiate fast-medium bowlers ($31.5 \pm 1.9 \text{ m.s}^{-1}$). Two gen-locked video cameras operating at 50 Hz, situated in the same horizontal plane with their optical axes orthogonal to one another, were used to film 6 deliveries bowled by each participant. The fastest delivery, as measured by a radar gun previously validated by Glazier, Paradisis and Cobner (1999), was digitised and subjected to kinematic analysis. Anthropometric lengths, including shoulder-elbow, elbow-wrist and hand length, were also measured according to the guidelines described by Martin, Carter, Hendy and Malina (1988) and Ross and Marfell-Jones (1991). The results of this study showed a relationship between run-up speed during the pre-delivery stride and ball release speed ($r = 0.728$, $P = 0.026$). This finding agrees with those of Stockill and Bartlett (1992a) and can be explained by the majority of bowlers analysed used techniques that exhibited a front-on body position at back foot impact and, therefore, could transfer linear velocity generated during the run-up to ball release more effectively (Elliott & Foster, 1984). Relationships were also found between shoulder-wrist length and ball release speed ($r = 0.626$, $P = 0.036$) and total arm length and ball release speed ($r = 0.583$, $P = 0.050$), thus concurring with the suggestions of Stockill and Bartlett (1994). Using a similar method to Elliott *et al.* (1986), the relative contribution of the run-up to ball

release speed was 16%, hip rotation 2%, trunk action 6%, arm action 62%, and hand and finger action 14%. These results were broadly similar to Elliott *et al.* (1986) but somewhat different to Davis and Blanksby (1976a). Further evidence of proximal-to-distal sequencing was provided by Glazier *et al.* (2000). However, as only peak linear speeds of joint centres in the upper body kinetic chain were reported, the interaction or coupling relationships among body segments could not be established.

Portus *et al.* (2004) examined the bowling actions of 42 high performance male fast bowlers at the Australian Institute of Sport between 1996 and 1999 to establish the biomechanical factors most related to ball release speed and lower trunk injury. Three-dimensional kinematic data were generated by manually coordinate digitising movement sequences captured on film at 100 Hz in 1996 and on video at 50 Hz between 1997 and 1999. Two force platforms, operating at 1000 Hz and positioned at the location of back foot impact and front foot impact, were used to collect simultaneous ground reaction force data during every data collection session throughout the 4-year period. The results of this study showed relationships between front knee extension during the phase between front foot impact and ball release and ball release speed ($r = 0.37, P = 0.02$), peak braking force at front foot impact and ball release speed ($r = 0.43, P < 0.01$), time to peak braking force at front foot impact and ball release speed ($r = -0.32, P < 0.05$), and time to peak vertical force at front foot impact ($r = -0.65, P < 0.01$) and ball release speed. These findings indicate that bowlers who had higher braking forces, and developed their peak braking and vertical forces more rapidly at front foot impact, presumably through the use of a more extended front leg, recorded higher ball release speeds. Also, relationships were found between timing of the maximum hip-shoulder separation angle and ball release speed ($r = 0.34, P = 0.05$) and the range of shoulder axis rotation and ball release speed ($r = 0.30, P = 0.05$). Portus *et al.* (2004) argued that these findings suggested that an optimal sequence of hip and shoulder rotations is likely to exist, which would utilise more effectively the elastic energy created in the torso musculature through the delaying of shoulder axis rotation, ultimately resulting in an increased ball release speed.

Hanley, Lloyd and Bissas (2005) conducted a further three-dimensional kinematic analysis of 13 fast bowlers of varying standard (3 international seniors, 6 first-class seniors and 4 county juniors) to establish relationships between kinematic variables and ball release speed. Of the 74 variables analysed, only 5 were shown to be related to ball release speed. Most notably, run-up speed ($r = 0.592, P < 0.05$), trunk

angular displacement ($r = 0.642, P < 0.05$) and shoulder angular displacement ($r = 0.636, P < 0.05$) exhibited medium to large correlations with ball release speed. Owing to the large number of independent variables analysed, however, it would appear that the “shotgun” approach was adopted in this study. This approach, where the selection of independent variables is a largely arbitrary process (Lees, 1992), is typically not recommended and should be abandoned in favour of other more rational approaches, such as hierarchical or deterministic modelling (Lees, 1999).

Loram *et al.* (2005) attempted to identify the anthropometric, strength and kinematic parameters most related to ball release speed in a group of South African schoolboy fast-medium bowlers and then attempted to predict ball release speeds using those parameters as predictor variables in a multiple linear regression analysis. Each of the 12 bowlers studied were filmed performing 3 deliveries by a high-speed digital video camera operating at 250 Hz, which was situated perpendicular to the plane of performance. Anthropometric lengths and girths for torso and limb segments were measured by a trained anthropometrist and an isokinetic dynamometer set at an angular velocity of 1.05 rad.s^{-1} was used to measure peak concentric knee and shoulder torque and the angle at which these peak torques occurred. This study reported positive correlations between ball release speed and front knee angle at front foot impact ($r = 0.72, P = 0.009$) and ball release speed and front knee angle at ball release ($r = 0.71, P = 0.011$). In contrast to the suggestions of Stockill and Bartlett (1994) and the findings of Glazier *et al.* (2000), no relationships were found between limb lengths and ball release speed. Although no relationship existed between any of the shoulder and knee strength parameters and ball release speed, the angle of peak internal and external rotation torques of the shoulder were included in the multiple regression model, presumably because they were the only other independent variables not to exhibit colinearity, along with knee angle at front foot impact and ball release. The adjusted coefficient of determination (R^2) of 0.85 reported in the regression analysis indicated that 85% of the variance in ball release speed could be accounted for by the predictor variables. However, caution must be applied when interpreting these results as the response variable to predictor variable ratio was only 3:1, which is considerably less than the ratio of 20:1 considered to be ideal by Vincent (2005). This oversight is likely to limit the generalizability of the regression equation beyond this study.

Salter *et al.* (2007) conducted a preliminary investigation into the efficacy of different research designs when studying fast bowling performance. They compared the

results of single-participant and group-based analyses of the biomechanical factors most related to ball release speed. In the single-participant analysis, 20 deliveries bowled by a semi-open (defined as having a shoulder alignment of 210-240° at back foot contact) high-performance English academy fast bowler ($37.5 \pm 1.0 \text{ m.s}^{-1}$) in a competitive match were filmed by two synchronised high-speed video cameras operating at 250 Hz situated on the boundary edge. The movement sequences were subsequently digitised at 125 Hz and reconstructed using a direct linear transformation algorithm. In the group-based analysis, 20 semi-open high performance Australian academy fast bowlers ($34.2 \pm 1.6 \text{ m.s}^{-1}$) each bowled a single delivery, which was captured by an 8-camera Vicon system and reconstructed for subsequent analysis. A selection of kinematic performance parameters reported previously in the scientific and coaching literatures formed the basis of this analysis. The results of this study showed no relationships between any of the selected performance parameters and ball release speed in the group-based analysis, but relationships were found between 8 of the 11 performance parameters and ball release speed in the single-participant analysis. Four of these performance parameters (centre of mass velocity at back foot impact, maximum angular velocity of the bowling arm, vertical velocity of the non-bowling arm and stride length) were then entered into a multiple regression model to predict ball release speed. It was shown that 87.5% of the variation in ball release speed could be attributed to changes in these predictor variables. The stepwise introduction of independent variables into the multiple regression analysis also showed how previously high correlation coefficients between independent variables and ball release speed can be misleading, especially if colinearity exists among the independent variables. This finding provides further evidence that the “shotgun” approach adopted by Hanley *et al.* (2005) is ill-advised and that greater diligence and sound rationale needs to be applied when selecting independent variables.

In the most recent biomechanical investigation of fast bowling performance, Wormgoor *et al.* (2008) analysed 28 premier club fast-medium bowlers ($34.0 \pm 1.3 \text{ m.s}^{-1}$) from South Africa to identify the kinanthropometric, strength, and technique parameters most related to ball release speed. Each participant bowled six deliveries that were captured using six digital video camcorders operating at 50 Hz and the fastest delivery, as measured by a radar gun, was digitised and reconstructed using a three-dimensional direct linear transformation algorithm. In contrast to Stockill and Bartlett (1994) and Glazier *et al.* (2000), but in agreement with Loram *et al.* (2005), no relationship between limb lengths and ball release speed was found in this study. However, positive correlations were reported between the relative shoulder extension

strength and ball release speed ($r = 0.392$, $P = 0.039$) when the isokinetic dynamometer was set at an angular velocity of $1.05 \text{ rad}\cdot\text{s}^{-1}$, relative concentric shoulder internal-rotation strength at a mid-range position of 20° external rotation and ball release speed ($r = 0.428$, $P = 0.023$), and front knee angle at release and ball release speed ($r = 0.517$, $P = 0.013$). These results indicate that greater shoulder strength and a straighter front leg at ball release may result in higher ball release speeds, respectively. The change of knee angle during the phase between front foot impact and ball release exhibited a negative correlation with ball release speed ($r = -0.466$, $P = 0.013$) as did shoulder alignment in the transverse plane at front foot impact and ball release speed ($r = -0.466$, $P = 0.013$). Wormgoor *et al.* (2008) reasoned that the adoption of a more side-on shoulder alignment at front foot impact enabled bowlers to move their shoulder axis through a larger arc leading up to ball release, thereby increasing ball release speed. In fact, despite the well-documented injury problems caused by counter-rotation of the shoulder axis, this study encouraged the use of mixed bowling techniques where this parameter is the distinguishing feature.

2.2 Biomechanical Factors Associated with Bowling Accuracy

As noted earlier in section 2.0, there has been only one empirical study that has attempted to link fast bowling technique and bowling accuracy. Portus *et al.* (2000) examined the inter-relationships between selected physical capacities, technique, ball release speed and bowling accuracy of 14 first-grade or higher fast-medium bowlers ($32.1 \text{ m}\cdot\text{s}^{-1}$). In this study, each bowler was required to complete an 8-over bowling spell under simulated match conditions, of which the sixth ball of overs two, five and eight was recorded by two video cameras, one mounted overhead and the other mounted laterally, for digitizing purposes. An APAS image-based motion analysis system (Ariel Dynamics Inc.) was then used to digitize each of the recorded trials to obtain kinematic data describing the alignment of the back foot at back foot impact, the alignment of the shoulder axis throughout the delivery stride and the angle of the front knee between front foot impact and ball release. To obtain an objective measure of bowling accuracy, a cotton sheet marked with three rectangular scoring zones of various dimensions was suspended immediately in front of the batsman's stumps at the other end of the pitch. Each delivery of the 8-over bowling spell was awarded 25, 50, or 100 points depending on which scoring zone the ball struck. The number of points awarded to the bowler provided an indication of the accuracy of each delivery based on where the ball would

have passed the stumps with more points being awarded for good length, well-directed deliveries. A radar gun was also used to measure the ball release speed of each delivery.

The results of this study revealed substantially more variation in bowling accuracy than ball release speed, although the mean bowling accuracy score did not change significantly during the 8-over bowling spell. However, Portus *et al.* (2000) reported an increase in the amount of counter-rotation of the shoulder axis for the group of fast bowlers between overs 2 and 8 ($44 \pm 15.8^\circ$ vs. $48 \pm 16.3^\circ$; $F = 4.20$, $P = 0.026$). When the fast bowlers were grouped according to the type of bowling technique they were adopting (1 side-on, 5 front-on and 8 mixed), only the group of front-on fast bowlers exhibited an increase in the amount of counter-rotation of the shoulder axis during the 8 over bowling spell ($30 \pm 7.2^\circ$ vs. $37 \pm 8.1^\circ$; $F = 10.9$, $P = 0.006$). Pearson's product-moment correlation coefficients indicated an inverse relationship between total accuracy scores and the mean counter-rotation of the shoulder axis throughout the bowling spell ($r = -0.469$; $P = 0.071$). Moreover, an inverse relationship emerged between total accuracy scores and the amount of counter-rotation the shoulder axis between overs 5 and 8 ($r = -0.542$, $P = 0.045$). From these results, one may speculate that fast bowlers exhibiting a mixed bowling technique are likely to be less accurate than fast bowlers adopting side-on or front-on techniques. However, front-on fast bowlers may become less accurate during a prolonged bowling spell because of their tendency to increase the amount of counter-rotation of the shoulder axis when fatigued.

Although Portus *et al.* (2000) provided a useful insight into fast bowling accuracy, it failed to contribute significantly to our understanding of the biomechanical and motor control processes underpinning bowling accuracy. A major limitation of the research design used by Portus *et al.* (2000) was that only the 6th ball bowled by each fast bowler during overs 2, 5 and 8 (i.e. 3 out of 48 deliveries) was selected for kinematic analysis. The rationale for using this protocol was based on a similar study by Burnett *et al.* (1995), which examined the effects of a 12-over bowling spell on selected physiological and biomechanical variables in a group of nine potentially elite fast bowlers. In this study, Burnett *et al.* (1995) reported no difference between selected kinematic variables of the fifth and sixth deliveries bowled by each fast bowler during overs one, six, ten and twelve, thus suggesting that the use of a single trial to represent technique at each of these intervals during the spell of bowling was acceptable. However, considering the amount of variability in the accuracy scores reported by Portus *et al.* (2000), and the assumed causal relationship between technique and

accuracy score, their results might simply be an artifact of the research design owing to low statistical power.

2.3 Summary of Key Research Findings

The following general conclusions can be drawn from the research reviewed above on the biomechanical factors associated with fast bowling performance:

- The ‘optimum’ run-up speed appears to be individual-specific but is typically in the range of 4.0-6.0 m.s⁻¹. The majority of studies suggest that higher run-up speeds produce higher ball release speeds (Burden & Bartlett, 1990b; Stockill & Bartlett, 1992a; Stockill & Bartlett, 1994; Glazier *et al.*, 2000; Hanley *et al.*, 2005; Salter *et al.*, 2007).
- There is some evidence to suggest that side-on bowlers have a slower run-up than front-on bowlers, which enables them to change orientation better during their pre-delivery stride (Penrose *et al.*, 1976; Elliott & Foster, 1984).
- Side-on bowlers tend to rely on hip and shoulder rotation to generate ball release speed whereas front on bowlers appear to use more of the linear velocity generated during the run-up (Elliott & Foster, 1984).
- There is no evidence to suggest that the side-on action is superior to the front-on action in terms of generating ball release speed, although a number of studies (Davis & Blanksby, 1976b; Elliott *et al.*, 1986; Stockill & Bartlett, 1992a; Portus *et al.*, 2004; Hanley *et al.*, 2005; Wormgoor *et al.*, 2008) have shown that a greater range of motion of the hip and shoulder axes in the transverse plane might be related to the production of greater ball release speeds. This finding might explain why some fast bowlers counter-rotate their shoulder axis between back foot impact and front foot impact (i.e., so they can move their shoulder axis through a larger arch leading up to ball release).
- A straight, or even hyper-extended, front leg at ball release appears to be related to greater ball release speeds (Davis & Blanksby, 1976b; Burden & Bartlett, 1990b; Stockill & Bartlett, 1992b; Portus *et al.*, 2004; Loram *et al.*, 2005; Wormgoor *et al.*, 2008), although there is some conjecture about whether landing with a straight front leg at front foot impact produces higher ground reaction forces and loading rates than a flexed front leg (Elliott & Foster, 1984; Elliott *et al.*, 1992; Portus *et al.*, 2004).

- The ‘optimum’ front leg action is considered to be one that lands extended or slightly flexed followed by a phase of flexion to absorb shock and then vigorous extension up to release (e.g., Bartlett, 1992; Bartlett *et al.*, 1996). However, several studies have shown that bowlers exhibiting flexion of the front knee between front foot impact and ball release are likely to have lower ball release speeds than those who do not (Burden & Bartlett, 1992a; Wormgoor *et al.*, 2008).
- The use of the non-bowling arm appears to be more important in side-on bowlers where it is used to more effectively summate segmental velocities (Elliott & Foster, 1984).
- The action of the bowling arm has consistently shown to be the most significant contributor to ball release speed (Burden & Bartlett, 1990a,b; Davis & Blanksby, 1976b; Elliott *et al.*, 1986; Glazier *et al.*, 2000), which is hardly surprising given that linear speed is a product of radial length and angular velocity and that the bowling arm represents the longest lever in the upper extremity link segment system.
- There is a sequential proximal-to-distal increase in the linear speed of joint centres comprising the kinematic chain (Elliott *et al.*, 1986; Burden & Bartlett, 1990a,b; Glazier *et al.*, 2000). Faster bowlers tend to have higher joint linear speeds than slower bowlers (Stockill & Bartlett, 1994) and this difference appears to be more marked in more distal joint centres (Burden & Bartlett, 1990b).
- There is mixed evidence about the role of anthropometric variables on ball release speed (Stockill & Bartlett, 1994; Glazier *et al.*, 2000; Loram *et al.*, 2005; Wormgoor *et al.*, 2008). From a purely mechanical standpoint, considering that the bowling arm is constrained by the laws of cricket to act as a quasi-rigid lever, an increase in the radial length would lead to a greater linear velocity of the end-point for a given angular velocity. However, because the moment of inertia of the lever would increase proportionally, greater torque would need to be generated at the shoulder. This suggestion is supported by some evidence showing a relationship between various shoulder strength variables and ball release speed (Loram *et al.*, 2005; Wormgoor *et al.*, 2008).

- A mixed action might be less accurate than side-on and front-on actions with greater shoulder counter-rotation leading to greater inaccuracies (Portus *et al.*, 2000).

2.4 Limitations of Existing Studies and Opportunities for Further Research

The empirical investigations reviewed in sections 2.1 and 2.2 and summarised in section 2.3 provide some useful insights into the biomechanical factors that contribute to proficient fast bowling performance. However, it could be argued that this information amounts to little more than what is already known in the coaching literature and serves only to reinforce, rather than extend, this body of knowledge. This lack of advancement might be attributable, at least in part, to these studies being too descriptive, relying too heavily on anecdotal evidence, lacking a sound theoretical rationale, being plagued by methodological issues, and generally not showing good use of statistical analysis techniques or an awareness of their underlying assumptions. The almost exclusive focus on group analyses, where the emphasis has been on the pooling of performance parameter data to examine central tendencies and dispersions, has tended to mask differences between fast bowlers. The obscuring of individual differences is an important issue that requires attention given that individuality of fast bowling techniques has become a ‘hot topic’ in the coaching literature recently (e.g., Cooley, 2003, 2005). Moreover, the emphasis on the quantitative analysis of outcome variables (e.g., ball release speed, peak joint speeds, segment angles and alignments) has generally precluded insights from being made into the qualitative³ aspects of technique (i.e., coordinative movement patterns), which has restricted the application of this research in a practical context. Further research is required to understand the causative mechanisms and processes producing these outcome measures, but if this aim is to be realised the reductionist, nomothetic (inter-individual), product-oriented approach habitually used in sports biomechanics needs to be superseded by a more appropriate research strategy. The holistic, idiographic (intra-individual), process-oriented approach advocated by proponents of dynamical systems theory appears to be particularly well-suited to this research endeavour.

³ The term ‘qualitative’ is used here to refer to geometric properties of movement as disclosed, for example, by the application of topological dynamics (see McGinnis & Newell, 1982) **not** the analysis of human movement via the observation and subjective evaluation of video sequences as is traditionally used in biomechanics (see Knudson & Morrison, 2002) and applied to cricket fast bowling, for example, by Hurron and Hamer (2003).

Chapter III

Theoretical Development of the Biomechanics-Motor Control Nexus

3.0 Introduction

In the final section of Chapter II, it was concluded that future empirical research into the biomechanics of fast bowling performance requires an alternative approach to those used previously if substantive progress is to be made. The holistic, idiographic (intra-individual), process-oriented approach advocated by dynamical systems theorists was identified as having much promise both for enhancing our understanding of the biomechanics and motor control of fast bowling performance and performance-oriented sports biomechanics research more generally. Although a dynamical systems approach has been adopted in biomechanical studies previously, these investigations have typically been injury-oriented (e.g., Hamill, van Emmerik, Heiderscheit & Li, 1999; Stergiou, Jensen, Bates, Scholten & Tzetzis, 2001) and the wider implications for sports biomechanics of conceptualising human movement systems as non-linear dynamical systems has seldom received coverage in the literature. Following an introduction of the main tenets of dynamical systems theory and their application to human motor control, learning and performance, the wider implications for sports biomechanics are discussed in some detail in this chapter.

3.1 Movement Systems as Dynamical Systems

Broadly speaking, non-linear dynamical systems are those physical, chemical, biological or social systems that exhibit many independent component parts or degrees of freedom which are free to vary over space and time. These complex systems are typically 'open' systems that operate under conditions that are said to be far-from-thermodynamic equilibrium—that is, they are capable of interacting with the environment and are in a constant state of flux owing to changes in internal and external energy flows (e.g., Kugler & Turvey, 1987; Thelen & Smith, 1994; Wallace, 1996). Despite the potential for disorder, complex non-equilibrium dynamical systems can exploit these energy flows and the surrounding constraints to form orderly and stable relationships among the many degrees of freedom at different levels of the system (e.g., Kugler, 1986; Kaufmann, 1993; Clark, 1995).

In the human movement system, dynamical systems theorists suggest that functional coordinative states, or attractor states in dynamical systems parlance, are not an artefact of a motor program, plan, or schema stored in the higher regions of the brain as proposed by information-processing theorists, but, rather, they are an emergent property of generic processes of physical self-organisation that are ubiquitous in

physical and biological complex systems and constraints that limit and define the operational boundaries of the system (e.g., Newell, 1986; Clark, 1995; Kelso, 1995; Thelen, 1995). At the level of muscular-articular links, the number of biomechanical degrees of freedom to be regulated can effectively be reduced by the spontaneous formation of functional muscle synergies (Bernstein, 1967; Gelfand, Gurfinkel, Tsetlin & Shik, 1971) or coordinative structures (Greene, 1972; Turvey, 1977). Tuller, Turvey and Fitch (1982) defined a coordinative structure as “... a group of muscles often spanning several joints that is constrained to act as a single functional unit” (p. 253) with sets of coordinative structures being functionally, rather than mechanically, combined to provide action sequences. A characteristic of a coordinative structure is that, if one of the component parts introduces an error into the common output, the other component parts automatically make compensatory adjustments to minimise the effect of the original error (Turvey, 1990; Latash, Scholz & Schöner, 2002). Furthermore, the ‘soft assembly’ of coordinative structures affords great flexibility and adaptability as individual muscles can participate in different coordinative structures on different occasions (Kugler & Turvey, 1987; Kay, 1988). These task-specific structural units can be modulated or tuned by perceptual information to accommodate sudden, unforeseen changes in task demands (Fitch, Tuller & Turvey, 1982; Bingham, 1988).

As noted above, the formation of coordinative structures is dependent not only on processes of self-organisation but also the constraints imposed on specific movement systems. The constraints concept has a rich tradition in theoretical physics, evolutionary and theoretical biology, and mathematics. Broadly, constraints are internal or external boundaries, limitations or design features that restrict the number of possible configurations that complex systems can adopt (Sparrow & Newell, 1998). In their founding paper, Kugler, Kelso and Turvey (1980) underscored the importance of constraints in emergent, rather than prescriptive, explanations of human movement by stating that: “... the order in biological and physiological processes is primarily owing to dynamics and that the constraints that arise, both anatomical and functional, serve only to channel and guide dynamics; it is not that actions are caused by constraints it is, rather, that some actions are excluded by them” (p. 9). Newell (1986) extended this initial theorising and outlined a theoretical model in which three categories of constraint—organismic, environment and task—coalesce to channel and guide emergent patterns of coordination⁴ and control⁵ produced by the movement system (see Figure

⁴ Coordination is the relationship between either the movements of limb segments of the same limb (intra-limb coordination) or the relationship between the movements of different limbs (inter-limb

3.1). It is important to note, however, that these categories of constraint identify the source, rather than the actual nature, of the constraint (Newell, van Emmerik & McDonald, 1989).

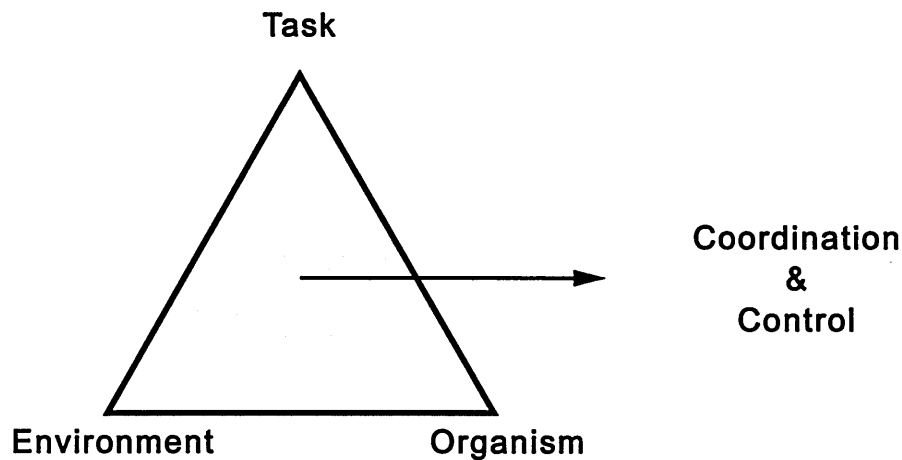

Figure 3.1. Newell's theoretical model of interacting constraints (reproduced from Newell, 1986).

Newell (1986) considered *organismic constraints* to be those constraints that are internal to individual movement systems. Organismic constraints can be subdivided into structural and functional constraints. Structural organismic constraints tend to be physical constraints that remain relatively constant over time and include: stature, body mass and composition; genetic make-up; anthropometric and inertial characteristics of the torso and limbs; the number of mechanical degrees of freedom and ranges of motion of articulating structures; fast- and slow-twitch fibre composition; angle of pennation, cross-sectional area, activation and fatigue characteristics of skeletal muscle; and so on (e.g., Jensen, 1993; Carson & Riek, 1998; Shemmell, Tresilian, Riek & Carson, 2004; Wagenaar & van Emmerik, 2000). All of these structural organismic constraints, especially anthropometric characteristics and the proportion of fast twitch muscle fibres

coordination). Intra-limb coordination defines the topology of the movement of a single limb, whereas inter-limb coordination defines how two or more limbs maintain a temporal and spatial relationship to each other (Sparrow, 1992).

⁵ Control refers to the absolute magnitude of the limb or limb segment movement. For example, the amplitude, velocity, acceleration, or force of the movement would dictate the degree of control. The goal of the task specifies an optimum or target value of one of these variables and a 'well-controlled' movement is one which satisfactorily approximates the optimum or target outcome. Furthermore, if kinetic or kinematic measures over time are used as dependent measures they are still indicative of control because they do not specify directly the pattern of limb or limb segment movements. They should not, therefore, be referred to as measures of coordination (Sparrow, 1992).

(Lillee, 1977; Hook, 1990; Glazier *et al.*, 2000), are important in cricket fast bowling. Functional organismic constraints that have a greater rate of change, on the other hand, tend to vary quite considerably over time and can either be physiological or psychological. Important functional organismic constraints include intentions, emotions, intelligence, perception, decision-making and memory. Obvious functional organismic constraints in fast bowling are muscle fatigue and cognitive anxiety. Perhaps the most prominent and influential organismic constraint that can shape movement coordination is the intentions of the specific individual under scrutiny (Kelso, 1995).

Environmental constraints, by contrast, are those constraints that are external to the movement system. They tend to be non-specific constraints that pertain to the spatial and temporal layout of the surrounding world or the field of external forces that are continually acting on the movement system. Environmental constraints are typically more challenging to manipulate during experimentation. Examples of environmental constraints include ambient light and temperature, altitude, acoustic information, ubiquitous gravitational forces and the reaction forces exerted by *terra firma* and other contact surfaces and apparatus. Newell (1986) originally made the distinction between environmental constraints that are general or ambient and those that are task specific. However, Newell and Jordan (2007) argued that it is much cleaner in a definitional sense not to force this distinction and they modified the definition of an environmental constraint to encompass any physical constraint beyond the boundaries of the organism. Any implements, tools or apparatus, which were originally categorised by Newell (1986) as being task constraints, are now classified as environmental constraints.

Task constraints are those constraints that are specific to the task being performed and are related to the goal of the task and the rules governing the task. They are not physical constraints but, rather, implied constraints or requirements that must be met within some tolerance range so that performance is successful (McGinnis & Newell, 1982). The constraints of the task operate as an umbrella over all other constraints in influencing what patterns of coordination and control are produced (Newell, 1986; Higgins, 1985; Clark, 1995). The relative impact of task constraints on the movement system is largely dependent on the motor activity being performed. For example, in cricket, the laws of the game state that the bowling arm must remain quasi-rigid and that it may not be extended during the course of delivery. Also, there is often the need to vary where the ball is to be pitched and the speed at which the ball is released. However, unlike in some other sports (e.g., gymnastics and swimming), the

task constraints do not specify the coordination pattern that must be used by the fast bowler and, consequently, a variety of techniques can be used against the backdrop of organismic, and to a lesser extent, environmental constraints.

One of the most profound, and possibly contentious, conceptual implications of Newell's (1986) model of constraints is that optimal patterns of coordination and control are borne out of, or emerge from, the unique confluence of constraints impinging on individual movement systems through a process referred to as 'self-organizing optimality'. This concept is tantamount to the 'constrained optimization' concept advanced in the theoretical and evolutionary biology literatures by, amongst others, Maynard Smith (1978) and Staddon and Hinson (1983). Constrained optimization states that the behaviour of a biological system at any time will always be optimal for the specific confluence of constraints acting on the system, or as Mazur (1983) put it, the system will "always do the best it can" (p. 977). Therefore, even though the pattern of coordination and control produced by the movement system might be optimal in relation to the immediately imposed constraints, the performance outcome could still be suboptimal or unsuccessful with regard to some externally defined criterion.

As the constraints imposed on an individual movement system can fluctuate continuously over time, the optimal pattern of coordination and control for any given motor activity can change accordingly. Furthermore, as the conscious and subconscious interpretation of these constraints is dependent on the intrinsic dynamics (i.e., preferred states of coordination and control based on movement system architecture, previous task experience, emotions, etc.) of each individual under scrutiny, optimal patterns of coordination and control for any given motor activity will always be individual-specific (Newell, 1986; Newell *et al.*, 1989). Inter-individual, and even intra-individual, variations in coordinative movement patterns over different timescales may, therefore, be interpreted as adaptive behaviour as each individual movement system attempts to exploit surrounding constraints to shape the functional, self-sustaining patterns of behaviour that emerge in specific performance contexts (Newell, Mayer-Kress & Liu, 2001). Clearly, these theoretical insights have important implications for sports biomechanics from a number of standpoints, which are discussed in some detail in the following sections.

3.2 Implications of Dynamical Systems Theory for Sports Biomechanics

Conceptualising human movement systems as complex, non-linear neurobiological systems (dynamical systems perspective) rather than information-driven machines finitely controlled via integrated sensory feedback loops by a capacity-limited microcomputer acting as the brain (information processing perspective), has significant ramifications for sports biomechanists studying them. Specifically, the idea that patterns of coordination and control are emergent properties of self-organising processes and the confluence of constraints impinging on the performer rather than a motor program, plan or schema containing a prescription of the desired movement response, including details about the duration, magnitude and relative timing of muscle activation characteristics, has important implications for: hypothesis generation (Davids & Glazier, 2010); research design (Glazier *et al.*, 2003); experimentation (Glazier *et al.*, 2006); inverse dynamics analyses (Glazier & Davids, 2009a); forward dynamics analyses (Glazier & Davids, 2009b); the use of ‘complex’ analyses (Glazier *et al.*, 2003; Wheat & Glazier, 2006); and interpretations of movement variability (Glazier *et al.*, 2006).

3.2.1 Hypothesis Generation

Recently, Gregor (2008) argued that the development of hypothesis-driven research must continue to improve in biomechanics, presumably because the hypothetico-deductive approach has been the most effective strategy over the years for providing new insights in biological research (e.g., Shephard, 1998) and because it is strongly advocated in core research methods textbooks in kinesiology and physical education (e.g., Thomas, Nelson, & Silverman, 2005). Contrary to this view, Winter (1987) argued that formal hypotheses had limited value in biomechanics and motor control research because of the great complexity of the human movement system and the associated difficulties with accurately predicting motor behaviour. Consistent with this perspective, dynamical systems theory suggests that accurate prediction of human motor performance for a given task at a given time is far from straightforward because of the existence of complex, non-linear, interactions between the many independent component parts of the human movement system at different levels of the system. In principle, small-scale changes at a more microscopic level of the system (e.g., molecular, cellular, neuromuscular) can have a large-scale impact at a more macroscopic level (e.g., behavioural, biomechanical, psychological) (e.g., Newell, 1996; Newell & Morrison, 1996). Furthermore, as implied by Newell’s (1986) constraints

model, not only is the current state of the human movement system important, the immediate environmental conditions and the specific requirements of the task being undertaken are also influential in shaping coordinative movement patterns.

As an alternative to formulating and testing rigid hypotheses, Winter (1987) suggested that a more insightful approach might be for investigators to “... perturb certain obvious variables and see what changes result” (p. 277). This approach is somewhat reminiscent of the strategy outlined by Kelso and colleagues (e.g., Kelso, Schöner, Scholz, & Haken, 1987; Kelso & Schöner, 1988) who, following Bernstein (1967), argued that greater understanding of persistent and transitory behaviour in the human movement system would be gained through the development of general organisational principles rather than attempting to discover hard-wired neural mechanisms. Their approach, termed the ‘synergetic strategy’, involves the scaling of non-specific ‘control’ parameters (internal or external variables that alter the organisational state of the system) and observing changes in ‘order’ parameters (collective variables that capture and define the organisational state of the system). However, as the identification of control parameters through theoretical analysis is not always possible in the movement system, a more efficacious method, according to Kelso (1995), might be to perturb the system and observe the changes in order parameter dynamics. This strategy has proven very effective in motor control, learning and development research at providing insights into the self-organising processes within and between levels of the movement system (e.g., Scholz & Kelso, 1989; Clark & Phillips, 1993; Thelen & Smith, 1994) and could turn out to be a viable alternative experimental paradigm for sports biomechanists. Indeed, a variation of this approach has been successfully applied by Hamill *et al.* (1999) in their investigation of lower extremity running injuries.

3.2.2 *Research Design*

Traditionally, cross-sectional, group-based research designs have been used in performance-oriented sports biomechanics research largely because the aim of many investigations has been to make inferences about the wider population from which the study sample was drawn in an effort to develop generalisable laws and principles that govern action (James & Bates, 1997). Two basic research designs have generally been adopted—the correlation approach and the contrast approach (Hay, Vaughan, & Woodworth, 1981). In the former, associations between the performance criterion

(independent variable) and the underlying performance parameters (dependent variables) derived from a single homogenous group of athletes are formally examined using relationship statistics (e.g., interclass correlation coefficients). In the latter, differences in the mean values of key performance parameters derived from two or more heterogeneous groups of athletes are formally compared using mean difference statistics (e.g., *t*-test, ANOVA). The majority of scientific investigations into fast bowling performance have used either the contrast (e.g., Stockill & Bartlett, 1994) or, more notably, the correlation (e.g., Glazier *et al.*, 2000; Portus *et al.*, 2004; Loram *et al.*, 2005) approach and, in almost all of these studies, a single ‘representative’ or ‘best’ trial performed by each participant has typically been analysed.

Despite the widespread use of group-based research designs in sport science research, they do have several pitfalls that need to be taken into consideration by sports biomechanists. One of the main issues is that the traditional approach of pooling group data to analyse central tendencies and dispersion (i.e., reporting group means and standard deviations) often masks differences between individuals (Gregor, 1989; Michaels & Beek, 1996; James & Bates, 1997). A good example of this statistical anomaly was provided by Dufek, Bates, Stergiou and James (1995). They reported the results of two experiments investigating individual and group responses during normal and perturbed landing and running trials. Irrespective of the movement examined, the group models produced data that were not representative of any of the individual performers that comprised that group. Similarly, Dufek and Zhang (1996) reported that group predictions for forefoot and rearfoot landing forces were not representative of any of the seven volleyball players analysed. By using pooled group data, the focus is very much on establishing the ‘average’ response for the ‘average’ individual, which has the effect of de-emphasising the individual performer (Bates, 1996). With this in mind, it has been recommended that the responses of different individuals should only be grouped after verification of any similarities or trends in the data, as similarities are likely to prove to be exceptions given the ever-changing confluence of constraints on performance (Bates, Dufek & Davis, 1992).

To enable individual differences to be explored more fully, it has been suggested that sports biomechanists need to implement more longitudinal, single-participant research designs (e.g., Bates, 1996; James & Bates, 1997; Bates, James & Dufek, 2004). This approach has not featured prominently in the biomechanics literature to date mainly because of issues relating to a lack of generalizability, but as Bates *et al.* (2004)

pointed out: “It is important to note that single-subject analysis does not imply ‘case study’ investigation. Rather, it is an experimental technique that invokes an in-depth examination of individuals in order to better understand what unique movement characteristics, if any, they have in common” (p. 5). In other words, just because multiple trials performed by an individual participant are analysed, it does not mean that they cannot or should not be compared with multiple trials performed by other participants. Indeed, Reboussin and Morgan (1996) argued that many investigations described as single-participant analyses are, in actual fact, multiple single-participant analyses. By enabling commonalities and differences to be established both within- and between-participants over repeated trials, multiple single-participant research designs can overcome some of the criticisms regarding generalizability often directed at single-participant research designs. A number of biomechanical investigations have successfully adopted multiple single-participant research designs previously, including those by Hreljac (1998), Dixon and Kerwin (2002), Wheat, Bartlett, Milner and Mullineaux (2003).

3.2.3 Experimentation

To avoid the arbitrary selection of independent variables in performance-oriented sports biomechanics research, the development of a theoretical model of performance for a given sports action is often recommended prior to data collection (e.g., Coleman, 2002). These performance models—introduced originally by Hay, Wilson and Dapena (1976)—have become known variously as ‘deterministic models’ (Hay & Reid, 1988), ‘factors-results models’ (Adrian & Cooper, 1995), ‘hierarchical models’ (Bartlett, 1999) and ‘qualitative models’ (Sanders, 1999), and have been applied to a range of sports skills, including gymnastics vaulting (e.g., Takei, 1998), water polo (e.g., Sanders, 1999), ice skating (e.g., Marino, 1983) and, most notably, track (e.g., Mann & Herman, 1985) and field (e.g., Young & Li, 2005) athletics. They are usually presented in the form of a block diagram and are similar in structure and composition to the one shown in Figure 3.2.

The first stage of constructing a deterministic model is to identify the result or outcome of performance—otherwise known as the performance criterion—which should be entered at the top of the model. The next stage of construction is to identify the mechanical factors—more commonly known as performance parameters—that

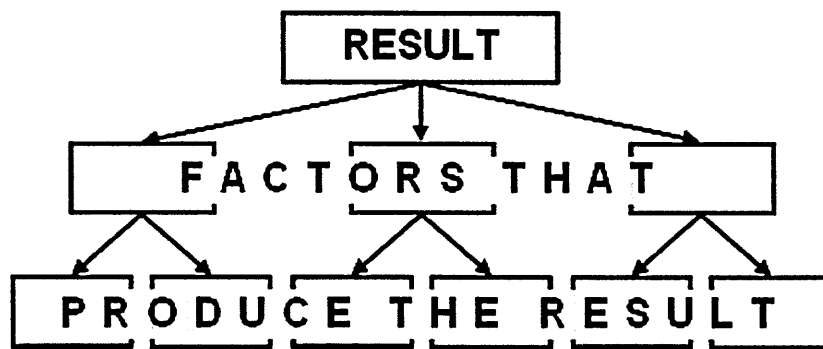

Figure 3.2. Basic format, structure and composition of a deterministic model (reproduced from Hay & Reid, 1988).

account for all the variance in the performance criterion. These performance parameters are then entered into the second tier of the model. The third stage is to identify the performance parameters that account for all the variance in the performance parameters in the second tier and enter these in the third tier of the model. This process is repeated until all relevant performance parameters are identified. According to Hay and Reid (1988) there are two main rules for constructing deterministic models: (i), where possible, performance parameters should be measurable mechanical quantities; and (ii), each performance parameter should be completely determined by those performance parameters that appear directly below it. The advantage of having a rigorously developed deterministic model of performance before data collection is that the selection of performance parameters can be justified on sound theoretical grounds (Bartlett, 1997; Lees, 1999). This approach, therefore, can be considered superior to the somewhat arbitrary ‘shotgun’ approach as the theoretical model helps to ensure that all the truly important variables are included and all the trivial ones are omitted (Hay, 1985; Lees, 1992; Yeadon & Challis, 1994).

Despite the widely accepted view that deterministic models can help identify faults in technique, their use has been surprisingly sparse. A number of reasons have been cited in the literature for their lack of utility (see Lees, 2002, for a review) but perhaps the most serious issue precluding the widespread use of deterministic models in performance-oriented sports biomechanics research is that they are models of *performance* not models of *technique*—that is, they are able to identify factors relevant to performance, but not necessarily aspects of technique relevant to these factors (Lees, 2002). In the hierarchical model of cricket bowling shown in Figure 3.3, for example, one of the most important performance parameters is release speed. Although some information about isolated aspects of technique that might be related to release

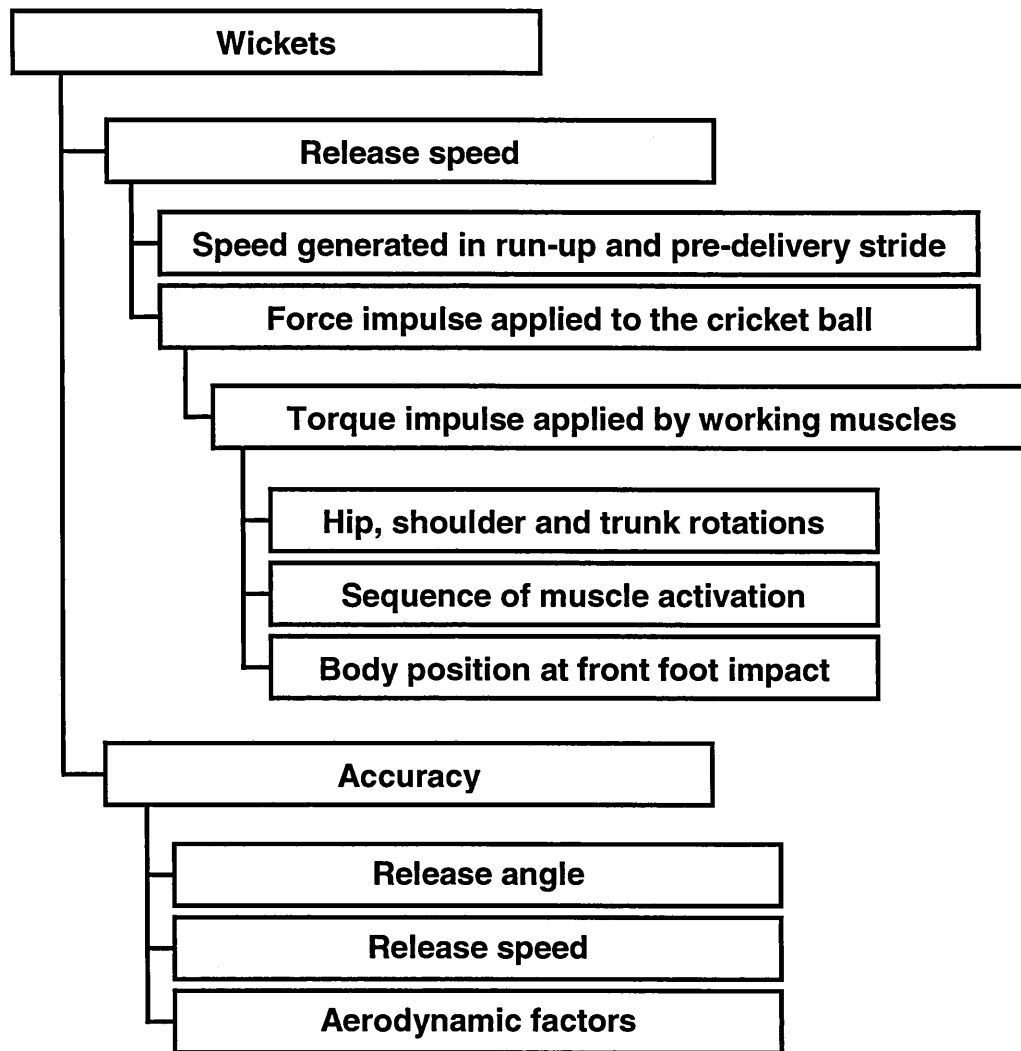

Figure 3.3. A simple deterministic or hierarchical model for cricket fast bowling. Although this model does not strictly conform to the criteria set out by Hay and Reid (1988) for constructing these performance models, it does provide an indication of the mechanical factors that are likely to be related to performance.

speed are provided, the model does not specify what movement patterns or, more precisely, coordination patterns that should be used to produce a high ball speed at the moment of release. Furthermore, it appears that the efficacy of such models is challenged because individual athletes scale and parameterise aspects of technique according to interacting organismic, environmental and task constraints impinging on performance (Newell, 1986). As a range of coordination patterns could be used to generate the same set of performance parameter values for any given motor skill (e.g., Bernstein, 1967; Arutyunyan, Gurfinkel & Mirskii, 1968; Marasso, 1981), sports biomechanists need to devote more attention to the causative mechanisms and processes underpinning performance.

3.2.4 *Inverse Dynamics Analyses*

In section 3.2.3, it was argued that sports biomechanists need to dedicate more attention to examining the causative mechanisms and processes underpinning performance. When attempting to establish the physical causes of motion, sports biomechanists typically use inverse dynamics analyses. Here, algebraic equations derived from Newtonian and Euler mechanics, combined with a link-segment model of the human body, are used to calculate joint torques and reaction forces, mechanical work and power transfers from kinematic data and participant-specific anthropometric (geometric and inertial) parameters for torso and limb segments acting as inputs (Zajac & Gordon, 1989). These kinetic analyses have provided a useful insight into what Winter (1989) termed the “final common mechanical pathway” (p. 338) in normal and pathological human motor functioning. Indeed, the general perception in biomechanics is that joint torques occupy an important role in obtaining a complete understanding of the human movement system, so much so, in fact, that Vaughan (1996) described them as the “holy grail” (p. 427). However, despite their apparent promise and potential contribution to enhancing performance and reducing injury, inverse dynamics analyses are still comparatively scarce, particularly in sports biomechanics.

There appears to be several reasons why inverse dynamics analyses have seldom been implemented in biomechanics research, including: the adequate complexity of models of the human movement system (e.g., Hatze, 2002); noise-contamination of displacement data and the subsequent propagation of errors as the signal undergoes numerical differentiation (e.g., Hatze, 1990); and errors in force magnitude and centre of pressure location when external force measurements are used (e.g., McCaw & Devita, 1995). However, the main issue has been one of indeterminacy in human movement system and the fact that inverse dynamics analyses belong to a class of ‘incorrectly’ or ‘ill-posed’ problems, that by definition, do not possess a unique (i.e., one and only one) solution. This issue was nicely demonstrated in a computer simulation by Hatze (2000) who showed that, for some motions, individual muscle forces may be perturbed to a considerable extent without significantly affecting the observable motions of the torso and limbs.

As it is currently not possible to measure individual muscle forces non-invasively with any degree of precision, a common ploy has been to reduce all muscle, bone and ligament forces crossing a joint together to a single vector (Vaughan, 1996). However, this approach does not provide any information about the contribution of

agonist and antagonist muscle action around a particular joint nor does it enable the contribution of an individual muscle within a particular group of muscles to be verified. From a dynamical systems perspective, being only able to measure the net or resultant joint torque precludes any substantive insight into coordinative structures beyond what has already been demonstrated, for example, by Winter (1984) and, therefore, it could be argued that the applicability of inverse dynamics analysis, in its current form, is limited in terms of its capacity to enhance knowledge on flexible and adaptable normal human motor functioning.

It is clear that biomechanists urgently need to improve their measurement techniques so that the contribution of individual muscles and groups of muscles to resultant joint torques can be established. This problem is not new and has previously been highlighted as one, if not the main, issue inhibiting progress in biomechanics research (Norman, 1989). As the movement system is inherently stochastic (Riley & Turvey, 2002), it is likely that the specific contribution of individual elements of coordinative structures over iterative performances of the same motor skill will range from being random to largely deterministic. By improving measurement methods, sports biomechanists will be able to investigate, and gain a better understanding of, the ubiquitous processes of physical self-organisation that underpin the formation of coordinative structures and the confluence of organismic, environmental and task constraints that determine the exact morphology of these task-specific structural units (e.g., Kugler *et al.*, 1980; Newell, 1986; Kelso, 1995).

3.2.5 *Forward Dynamics Analyses*

A major challenge facing sports biomechanists is that of identifying optimal techniques for the performance of a wide range of motor activities. In tackling this challenge, sports biomechanists have typically resorted to forward dynamics analyses or computer simulations, where sets of ordinary differential equations derived from Newtonian and Lagrangian mechanics are used to calculate optimal movement solutions (Miller, 1979). In a forward dynamics analysis, the input parameters are typically the applied forces or net joint torques acting on the movement system and the calculated output parameters are kinematic data describing the motion of the component parts (i.e., torso and limb segments) of the movement system. Although the accuracy and validity of these output parameters is largely dependent on the complexity of the mathematical model used to represent the movement system, it could be argued that, from a

dynamical systems perspective, the utility of this modelling approach in terms of its capacity to generate optimal movement solutions for specific individuals in specific performance contexts has been restricted because of the limited number of constraints that have been incorporated into these mathematical models. Indeed, as Newell (1985) highlighted: "... optimisation modelling has been largely confined to a consideration of mechanical constraints. However, mechanical constraints are clearly not sufficient criteria for optimisation in biological systems, although they represent an important beginning to this effort" (p. 305).

Owing to increased computer processing power, the number of constraints (or parameters as they are more commonly known in the biomechanics literature) that can be incorporated into mathematical models of the human movement system has grown steadily in recent years. For example, *organismic constraints* have been included in the form of individual-specific anthropometric (geometrical and inertial) parameters (e.g., Jensen, 1978; Yeadon, 1990), strength parameters (e.g., King & Yeadon, 2002; Yeadon, King & Wilson, 2006), soft tissue movement (so-called 'wobbling' masses) (e.g., Gruber, Ruder, Denoth & Schneider, 1998; Gittoes & Kerwin, 2006) and limits to joint ranges of motion (e.g., Wilson, Yeadon & King, 2007). *Environmental constraints* have also been included in the form of aerodynamic forces (e.g., Müller, Platzer & Schmolzer, 1996), contact surfaces (e.g., Wright, Neptune, van den Bogert & Nigg, 1998), apparatus (e.g., Hiley & Yeadon, 2005) and time-to-contact perceptual information of approaching projectiles (Beek, Dessing, Peper & Bullock, 2003). *Task constraints* have generally not been included in mathematical models of the human movement system but, rather, during the simulation process, typically in the form of an optimality criterion or specific cost function that must be maximised or minimised. These objective measures describe either the task goal or an aspect of performance that is strongly related to the task goal. Whereas other optimality criteria or cost functions, such as smoothness, accuracy, speed, minimum fatigue and minimum sense of effort have been used (e.g., Engelbrecht, 2001; Prilutsky & Zatsiorsky, 2002; Todorov, 2004), energy consumption or, more precisely, energetic efficiency, has typically been the chief optimality criterion or cost function in the biomechanical modelling of human motion (Sparrow, 2000).

From the preceding analysis, it would appear that, although the number of constraints incorporated into mathematical models of the human movement system has dramatically increased in recent years, claims that the complete optimisation of human

motion has already been realised (e.g., Hatze, 1976) might be premature, at least from a dynamical systems theoretical standpoint. Further work is needed to incorporate more organismic, environmental and task constraints into forward dynamics analyses because, as Newell (1985) argued, "... these constraints will determine the optimal coordination and control for a given individual in a given activity" (p. 305). Owing to the dynamic nature of sport, however, establishing generalised movement solutions for specific individuals in specific tasks is unlikely to be sufficient, especially for 'open' motor skills. The habitual use of a single optimality criterion in forward dynamics analyses has typically only enabled the optimal technique for a very narrow set of constraints for a given activity to be identified. For example, consider orienteering where the aim is to navigate to different locations across diverse and usually unfamiliar terrain in a short a period of time as possible. An optimisation model for orienteering might use energetic efficiency as its main overarching task constraint or optimality criterion given that the maximisation of mechanical work per unit of energy has been shown to be a fundamental principle governing human movement (Sparrow & Newell, 1998). However, the orienteer is continuously confronted by fluctuations in organismic (e.g., the onset of local muscle fatigue), environmental (e.g., changes in surface compliance, the topography of the landscape, changes in ambient temperatures) and task (e.g., reading a map) constraints. It is quite conceivable that these 'nested' constraints could preside over the optimality criterion at certain times during performance and, as such, movement patterns would be altered accordingly (e.g., Millett, Divert, Banizette & Morin, 2010).

Although orienteering is very much at the 'open' end of the 'open and closed continuum' for skill classification and a rather extreme example of how constraints on performance can fluctuate over different timescales, it is an effective task vehicle for illustrating some of the problems currently surrounding biomechanical optimisation modelling. The incongruency often found between the constraints used in the mathematical model of the human movement system or during the simulation process and the constraints of the performer-environment system, ultimately limits the effectiveness of biomechanical modelling in an applied context (e.g., when attempting to generate individual-specific movement templates to help identify faults in technique and direct remedial action). It could be argued, therefore, that from a dynamical systems theoretical standpoint, biomechanical optimisation not only needs to incorporate more organismic, environmental and task constraints in mathematical models of the human movement system and during the simulation process, but the relative impact of these

constraints needs to be varied according to the specific demands of the performance context. Only then will biomechanical modelling overcome the frequently made observation that it is merely an academic exercise with limited practical relevance and be able to justify its 'bio' prefix (e.g., Baumann, 1987).

3.2.6 'Complex' Analyses

Given the methodological issues currently inhibiting inverse and forward dynamics analyses (see section 3.2.4 and 3.2.5, respectively), which have taken on greater significance with the emergence of dynamical systems theory, it would appear that the efficacy and validity of moving beyond the kinematic level of analysis at the present time is questionable. Perhaps a more effective and amenable strategy given the current state of the art would be for sports biomechanists to use the analytical tools of dynamical systems theory to examine processes of coordination and control at the kinematic level of analysis. By using these so-called 'complex' analyses (Hamill *et al.*, 2006), sports biomechanists can effectively *measure* and *describe* coupling relationships between joints and limb segments. The subsequent application of principles and concepts from dynamical systems theory, such as self-organisation and constraints, can then be used to *explain* stability, variability and transitions among coordinative states and how these relate to the successful attainment or otherwise of the performance outcome.

A number of 'complex' analyses have been used in empirical studies of human movement, including:

Continuous relative phase (Kelso, 1995; Hamill, Haddad & McDermott, 2000; Kurz & Stergiou, 2004): Continuous relative phase measures the relative phase (the spatial and temporal coupling) of a pair of joints throughout the entire movement cycle. The relative phase angle can be obtained by calculating the four-quadrant arctangent phase angle from a phase-plane plot of each joint (Hamill *et al.*, 2000). Having normalized the time histories of the displacement and velocity data obtained from each joint, continuous relative phase can be calculated by subtracting the phase angle of one joint from that of the other joint at corresponding time intervals throughout the entire cycle. Providing that all the underlying assumptions are satisfied (see Kurz & Stergiou, 2002; Peters, Haddad, Heiderscheit, van Emmerik & Hamill, 2003), continuous relative phase can provide an indication of the type of relationship (in-phase or anti-phase) between the pair of joints and the relative amount of in-phase and anti-phase.

Cross-correlations (Amblard, Assaiante, Lekhel & Marchand, 1994; Li & Caldwell, 1999; Derrick & Thomas, 2004): Cross-correlations are based on the assumption that linear relationships exist between two sets of kinematic time series data (e.g., pairs of joints) but do not assume that these variables change in synchrony during the movement (Mullineaux, Bartlett & Bennett, 2001). By introducing time lags between data sets and calculating the corresponding correlation coefficients, researchers can obtain an indication of the type of relationship between body segments (in-phase or anti-phase), the degree of linkage between body segments, and the stability of coordination patterns when applied to repeated trials (Temprado, Della-Grasta, Farrell & Laurent, 1997). However, it is possible that similar cross-correlation coefficients can result from pairs of time series that have quite different relationships. Therefore, it may be prudent to interpret cross-correlation coefficients in conjunction with its time lag and qualitative measures such as angle-angle plots. Also, because cross-correlations measure linearity between time series, they are not particularly useful in determining the degree of linkage between body segments that have a non-linear relationship (Sidaway, Heise & Schoenfelder-Zohdi, 1995). In such circumstances, alternative techniques such as vector coding may be more informative.

Vector coding (Whiting & Zernicke, 1982; Sparrow, Donovan, van Emmerik & Barry, 1987; Tepavac & Field-Fote, 2001): Vector coding techniques are based on the chain-encoding technique devised originally by Freeman (1961). This procedure involves using a superimposed grid to transform the data curve from an angle-angle plot or a position-time plot into a chain of digital elements. Each of the digital elements that comprise the chain is given a weighting based on the direction of the line formed by the frame-to-frame interval between two successive data points. The chain of digital elements can then be cross-correlated with a chain of digital elements obtained from another angle-angle plot or position-time plot to obtain a recognition coefficient, which is the peak value of the cross-correlation function. The recognition coefficient can then be interpreted in much the same way as the cross-correlation coefficient outlined previously. A limitation of Freeman's (1961) chain-encoding technique is that it requires the data points to be equally spaced (Sparrow *et al.*, 1987). Moreover, this technique converts ratio scale data to a nominal scale, which limits the type of statistical analyses that can be applied and, therefore, may mask important information (Tepavac & Field-Fote, 2001). However, the recent introduction of a revised ratio scale, vector-based coding scheme to quantify relative motion data (see Tepavac & Field-Fote, 2001) appears to provide a satisfactory solution to these problems.

Kohonen Self-Organizing neural networks (Kohonen, 2001): The Kohonen Self-Organizing neural network has emerged in the movement sciences as a method for analyzing the global nature of movement patterns. Kohonen neural networks effectively compress high dimensional input data, such as three-dimensional kinematic data from multiple body segments, on to neurons located on a low dimensional topological map (Kohonen Self-Organizing Map) using a series of non-linear weighting vectors. Instead of visualising the ‘distance’ between performances in the high dimensional input space, the neighborhood preservation properties of self-organizing maps enable the investigator to visualise more effectively the ‘distance’ between performances in the low dimensional output space. A cluster analysis algorithm can then be used to categorize performances in terms of their topology, which can be determined by the amount of ‘distance’ between trials, where less ‘distance’ is thought to represent greater similarity (stability) and, therefore, lower levels of variability. Kohonen Self-Organizing neural networks have already been successfully applied to analyses of discus throwing (Bauer & Schöllhorn, 1997), javelin throwing (Schöllhorn & Bauer, 1998), soccer kicking (e.g., Lees & Barton, 2005) and, most notably, to gait analysis to evaluate walking patterns (e.g., Schöllhorn, Nigg, Stefanyshyn & Liu, 2002; Barton, Lees, Lisboa & Attfield, 2006; Janssen, Schöllhorn, Lubienetzki, Fölling, Kokenge, & Davids, 2008).

There are several reasons why the utilisation of these ‘complex’ analyses in conjunction with a dynamical systems theoretical framework could benefit performance-oriented sports biomechanics research:

1. ‘Complex’ analyses could be considered a suitable intermediary between ‘simple analyses’ habitually used by sports biomechanists, where the focus is typically on time-discrete kinematic data acquired from isolated joints, and inverse dynamics analyses. Although ‘complex’ analyses do not allow the forces and torques that cause movement to be quantified, they do at least allow the analysis of the interaction of joints and segments, which may, in turn, provide clues about the effectiveness of energy and momentum transfer along upper and lower extremity kinematic chains or the potential for injury from dysfunctional coordination patterning (e.g., Hamill *et al.*, 2006).
2. By using ‘complex’ analyses in conjunction with an experimental strategy that manipulates to their extremes, either singularly or in combination, a broad range of organismic, environmental and task constraints, it is possible to establish the

relative impact of different constraints on performance. The establishment of a hierarchy of constraints for specific individuals in specific activities could prove to be a valuable precursor to biomechanical optimisations (Glazier & Davids, 2009a).

3. It has been shown that athletes and coaches use relative motion information about the limbs and torso when making judgements about sports techniques (e.g., Sparrow & Sherman, 2001). When one also considers that athletes and coaches are unlikely to be able to relate well to concepts such as ‘net joint torques’ and ‘mechanical power transfers’, the analysis of coordination patterns at the kinematic level of the analysis appears to be a much more appropriate strategy on which to base applied work.
4. Many kinematic investigations featuring in the applied sports biomechanics literature have been criticised for being too descriptive and lacking a sound theoretical rationale (e.g., Norman, 1989; Bartlett, 1997; Hatze, 1998). Given its excellent pedigree in science and its focus on emergent pattern formation among the very many degrees of freedom that comprise complex systems (e.g., human movement systems), it could be argued that dynamical systems theory is a highly appropriate and applicable theoretical framework for performance-oriented sports biomechanics research.
5. It has frequently been suggested that biomechanists need to collaborate with scientists from other sub-disciplines of human movement science (e.g., Cavanagh & Hinrichs, 1981; Gregor, Broker & Ryan, 1992; Zatsiorsky & Fortney, 1993). Given its multidisciplinary focus, it would appear that dynamical systems theory could provide an effective platform for this collaborative work, especially among biomechanists and motor control theorists as advocated, for example, by Davids, Handford and Williams (1994) among others.

3.2.7 Interpretations of Movement Variability

As alluded to at the end of section 3.1, movement variability has great theoretical and operational significance in dynamical systems accounts of human movement. Indeed, Newell and Slifkin (1998) conjectured that “... contrary to traditional wisdom, it may be that the variance of movement dynamics is as revealing, or more revealing than, the invariance in terms of unpacking the nature of system organisation” (p. 157). However, despite the growing recognition of its importance, movement variability has not

typically featured high on the research agendas of sports biomechanists (although see Hatze, 1986, for early coverage) and only in the last decade has it been more widely acknowledged as an important topic worthy of research attention in its own right (see James, 2004; Bartlett, Wheat & Robins, 2007; and Bartlett, 2008, for recent reviews). There appears to be a number of inter-related reasons why researchers have generally overlooked this aspect of human motor performance:

First, biomechanical analyses examining the kinematics of human motion have typically been inhibited by the design of motion analysis equipment and the inefficiency of data reduction techniques. The main problem has been the time consuming, labour-intensive nature of manual coordinate digitising, which has typically restricted kinematic analyses to a single performance trial (normally the 'best' or a 'representative' trial in terms of performance outcome) (see also section 3.2.2). Furthermore, there has been some conjecture surrounding manual coordinate digitising and whether it is sufficiently sensitive enough to reliably detect differences in the kinematics of iterative performance trials of the same task (Bartlett *et al.*, 2006). These two factors combined have generally precluded analysis of intra-individual movement variability in sports biomechanics research.

Second, an implicit assumption held by many sports biomechanists is that movement patterns exhibited by skilled performers are invariant (Schmidt, 1985), or, at least, show a conspicuous tendency towards invariance (Heuer, Schmidt & Ghodsian, 1995). This assumption appears to have been perpetuated by the motor program concept that has dominated the movement sciences for the past three decades (e.g., Keele, 1968; Schmidt, 1982) and the implicit or explicit adoption of an information processing theoretical framework (e.g., Marteniuk, 1976) by sports biomechanists. Consequently, any intra-individual movement variability over iterative performance trials of the same task has typically been deemed to represent 'noise' or 'error' and, therefore, disregarded because it has been interpreted as having negligible practical significance. On the premise that movement patterns are highly consistent over repeated trials, the analysis of a single performance trial has been justified on the grounds that it is more or less 'representative' of a performer's normal technique. With the recent emergence of dynamical systems theory, however, there has been growing recognition of the need to analyse multiple trials as the validity of using a single performance trial to represent generalised performance outcomes has been shown to be questionable (e.g., Bates *et al.*, 1992; Dufek, Bates & Davis, 1995).

Third, another implicit assumption often held by sports biomechanists is that a common optimal movement pattern exists for a given motor skill. In other words, it is believed that there is a single most efficient and effective way of performing a motor skill for the majority of the population (Brisson & Alain, 1996). On the basis that highly skilled performers are likely to be in closer proximity to this template technique than their lesser skilled counterparts, pooled group data from the respective groups are typically compared using inferential statistics to establish 'normative' or 'soll' values (Schöllhorn, 2003) that may be used to characterize a hypothetical ideal technique or motor template. However, as noted in section 3.2.2, when pooling group data to analyse central tendencies and dispersions, inter-individual variability tends to get obscured. In effect, by using inferential statistics in this capacity, sports biomechanists are attempting to establish an 'average' response for an 'average' participant even though the 'average' individual might not exist (Bates, 1996). As Kelso (1995) noted: "Because each person possesses his or her own 'signature', it makes little sense to average performance over individuals. One might as well average apples and oranges." (p. 161). Sports biomechanists must, therefore, apply caution when adopting group-based research designs and be more amenable to alternative research designs and methodologies, such as multiple single-participant research designs and 'complex' analyses, where differences within and between individual performers are the main focus.

Fourth, the habitual use of deterministic or hierarchical performance models as a basis for applied research has encouraged sport biomechanists to adopt a reductionist approach as they seek to establish statistical associations between performance parameters and the performance criterion. However, as noted in section 3.2.3, these performance parameters provide little, if any, information about the underlying movement patterns that generate these performance parameters (Lees, 2002). By focusing almost exclusively on outcomes, sports biomechanists have been unable to analyse the often functional role that movement variability occupies in producing consistent and stable outcomes (e.g., Bernstein, 1967; Arutyunyan *et al.*, 1968; Marasso, 1981). In some respects, the deterministic or hierarchical modelling approach habitually used in sports biomechanics shares many of the problems that have traditionally plagued empirical studies in motor behaviour research (i.e., they have typically been product-driven rather than process-driven). It is instructive to note, however, that motor control theorists are increasingly resorting to biomechanical data collection and analysis methods to analyse the movement dynamics of multiarticular actions in their natural environment rather than relying on the outcome or error scores

obtained from small and simple laboratory-based paradigms (e.g., see Davids, Renshaw & Glazier, 2005, for cricket-related examples). Sports biomechanists urgently require a similar shift of emphasis towards analysing processes rather than focusing predominantly on outcomes.

Fifth, any observed variability in kinematic time series data has invariably been treated as random measurement errors, which are independent of, and additive to, the signal representing the movement (van Emmerik, Hamill & McDermott, 2005). To avoid the amplification and propagation of these errors during derivative calculations, it has been customary for biomechanists to remove measurement error from time series data using recognized data filtering and smoothing techniques (e.g., Wood, 1982). However, in doing so, some of the dynamical noise, which is generated by underlying non-linearities in the system and is an integral part of the signal (van Emmerik *et al.*, 2005), is likely to have been removed inadvertently, therefore, distorting the moment-to-moment structure of variability in the time series. Although there are apparently analytical procedures that enable measurement noise to be distinguished from dynamical noise (e.g., Siefert, Kittel, Friedrich & Peinke, 2003), these appear to be non-trivial and have not been incorporated into biomechanics research. Instead, some researchers (e.g., Buzzi, Stergiou, Kurz, Hageman & Heidel, 2003) have recommended not using any data smoothing or conditioning techniques to avoid omitting important data, whilst other (e.g., Hamill *et al.*, 1999) have applied digital filters but have used a higher cut-off frequency than is typical in biomechanics, presumably to avoid removing some of the dynamical noise content. Sports biomechanists need to be more mindful of the presence of dynamical noise in time series data and preserve it where possible.

3.3 Summary

Adopting a dynamical systems approach in biomechanics, until now, has typically meant the analysis of intra-limb and inter-limb and torso coordination or coupling relationships (e.g., Hamill *et al.*, 1999; Stergiou *et al.*, 2001). However, based on the information presented in this chapter, it would appear that this interpretation is too narrow and that adopting a dynamical systems theoretical framework has much wider ramifications for a range of contemporary issues related to performance-oriented sports biomechanics research. As noted above, conceptualising movement systems as non-linear dynamical systems questions the need for rigid hypotheses, emphasises an idiographic (intra-individual) rather than an nomothetic (inter-individual) approach,

necessitates the analysis of underlying causative processes rather than describing outcome effects, and requires a greater consideration of the theoretical and operational significance of movement variability.

In terms of the connotations for this thesis, the methodological problems associated with forward and inverse dynamics analyses indicate that moving beyond the kinematic level of analysis, at the present time, is questionable. Given that inverse dynamics analyses cannot currently be used to measure the contribution of individual muscle forces and, therefore, provide very little additional information about coordinative structures, and the fact that forward dynamics analyses cannot currently identify individual-specific optimal movement solutions, focusing on the stability and variability of coordinative movement patterns at the kinematic level of analysis in cricket fast bowling might be a more profitable strategy. When one also considers the applied theme of this thesis and the fact that research has shown that athletes and their coaches make judgements about technique based on the relative motion of limb and torso segments (e.g., Sparrow & Sherman, 2001), this line of enquiry has sound rationale.

Chapter IV

Methods

4.0 Introduction

This chapter provides a detailed account of the methodological procedures used to acquire and condition the kinematic data used in the empirical studies described in Chapters V, VI and VII. The demographics of the study sample, and the experimental protocol, data collection, data reconstruction and data processing procedures adopted during, and subsequent to, this session are outlined in sections 4.1, 4.2, 4.3, 4.4 and 4.5, respectively. The data analysis techniques specific to the individual chapters are analysed therein.

4.1 Participants

Eight male fast bowlers from the Cardiff-Glamorgan University Centre of Cricketing Excellence and the Glamorgan County Cricket Academy were recruited for this study (see Table 4.1). These bowlers were selected on their ability to release the cricket ball at speeds classified as either fast-medium ($27.0 - 36.0 \text{ m.s}^{-1}$) or fast ($36.1 - 40.5 \text{ m.s}^{-1}$) according to criteria laid out by Abernethy (1981). All bowlers had represented their respective counties at junior level and/or university in the premier division of the British Universities Sports Association's cricket competition. Each bowler was required to read and sign informed consent proformas (see Appendix A) prior to data collection as recommended by the British Association of Sport and Exercise Sciences (Payton & Bartlett, 2008). A verbal explanation of the testing procedures was provided where necessary. Ethics clearance was obtained from the local university ethics committee.

Table 4.1. Characteristics of the study sample.

Bowler	Age (yrs)	Stature (m)	Mass (kg)	Mean Ball Release Speed (m.s^{-1})	Classification
1	22	1.85	91.3	33.72	Fast-medium
2	16	1.92	75.2	30.18	Fast-medium
3	20	1.84	86.1	32.05	Fast-medium
4	17	1.82	76.0	30.86	Fast-medium
5	21	1.88	92.4	30.93	Fast-medium
6	18	1.73	68.5	31.37	Fast-medium
7	17	1.74	85.6	32.34	Fast-medium
8	20	1.83	83.5	30.06	Fast-medium
Mean	18.9	1.83	82.3	31.44	-
SD	2.17	0.06	8.37	1.23	-

4.2 Experimental Protocol

All testing took place indoors at the Glamorgan National Cricket Centre at Sophia Gardens, Cardiff, Wales, on a standard-sized cricket pitch, which had a Uniturf 6-mm

synthetic rubber surface with a 12-mm impact-absorbent underlay. The approach run area was approximately 30 m in length, which enabled all bowlers to use their full run-up. The participants were instructed to undertake a cricket related warm-up activity of their own choice. Each participant was permitted to bowl 6 practice deliveries to facilitate familiarisation with the testing environment before bowling 12 successful deliveries at maximum effort. A delivery was deemed to be successful if it struck a 0.3 × 0.3 m target attached to the top of the off-stump after pitching. All deliveries were bowled with a Readers Sovereign cricket ball compliant with MCC specification (mass 0.156 – 0.163 kg and circumference 0.224 – 0.229 m) (Marylebone Cricket Club, 2009). All items of clothing were removed except training shoes and sports shorts in order to facilitate the identification of anatomical landmarks. No superficial markers were used as this was a three-dimensional study and superficial markers would not necessarily have provided an indication of joint centres.

4.3 Data Collection

Two 3-CCD Sony DSR-PD150P digital video camcorders (Sony Corporation, Japan) were mounted upon stationary Manfrotto #117 rigid tripods (Vitec Group, Italy) fitted with Manfrotto #136 heads (Vitec Group, Italy) to record each trial for digitising purposes. Both camcorders were equipped with 6.0 to 72.0 mm zoom lenses and were mounted at heights of 1.20 m (measured using a plumb-line). Both were operating at 50 fields per second with electronic shutter speeds of 1/1000 s to eliminate image smear. A distance-to-base ratio (i.e., the ratio of perpendicular distance from a mid-camera point to participant to the distance between cameras) of 1:2, as recommended by Wood and Marshall (1986), was selected so that the optical axes of the camcorders intersected orthogonally over the area of performance (see Figure 4.1). Although the direct linear transformation (DLT) method can produce acceptable reconstruction accuracy with convergence angles ranging from 60° to 120°, errors increase as the convergence angle deviates away from 90° (Bartlett, 2007). This camera configuration had previously been used by Glazier *et al.* (2000) in their three-dimensional kinematic analysis of bowling techniques used by collegiate fast-medium bowlers and was shown to minimise the occlusion of upper extremity anatomical landmarks during the delivery stride. The focal length of each camera was adjusted to maximise the size of the calibration volume in the viewfinder, thereby maximising the potential accuracy of the resulting digitised kinematic data.

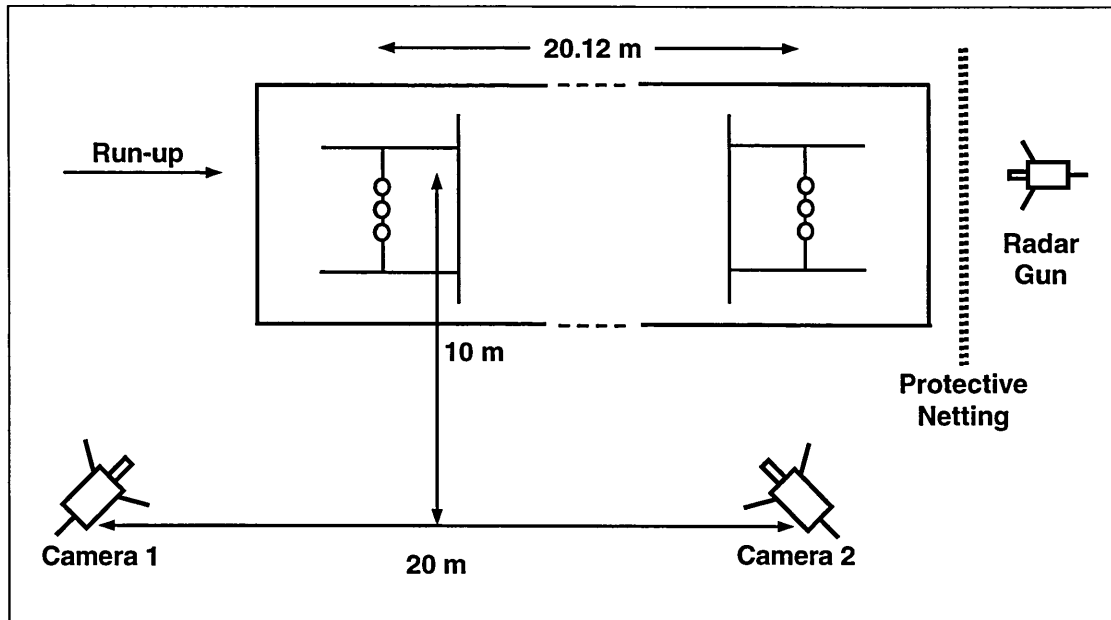

Figure 4.1. A plan view of the data collection setup (not to scale).

To obtain scaling data required for camera-digitising system calibration, a calibration pole containing three spherical control points ($\phi = 0.1$ m) was moved sequentially through six pre-measured locations around the perimeter of the area of performance (see Figure 4.2). Challis and Kerwin (1992) demonstrated that control points distributed around the outside, rather than within, the volume to be calibrated produced superior reconstruction results. Although only 6 non co-planar control points are required in each camera view to generate the 11 parameters required to implement the DLT algorithm (Abdel-Aziz & Karara, 1971), additional control points have been recommended to increase the accuracy of the resulting data (e.g., Shapiro, 1978). Indeed, Chen, Armstrong and Raftopoulos (1994) showed that 16-20 control points are necessary for good calibration accuracy when using the DLT method. Another advantage of using additional control points is that they can be used to generate the extra DLT parameters required to correct linear (symmetrical) and non-linear (asymmetrical) lens distortions (Marzan & Karara, 1975). All digitised movement took place within the calibration volume measuring $2.3 \times 4.0 \times 2.1$ m (19.32 m³), thus avoiding errors associated with extrapolation outside of the control point distribution (Wood & Marshall, 1986).

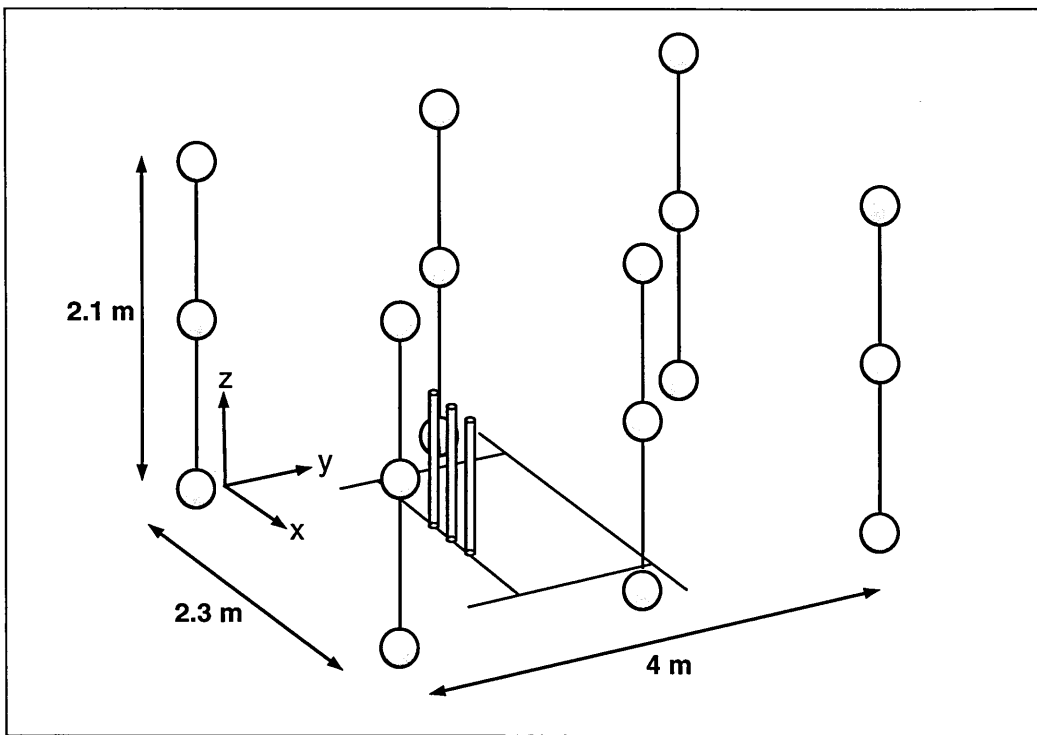

Figure 4.2. A three-dimensional view of the calibration volume (not to scale).

Ball release speeds were measured using a Stalker Professional Sports Radar (Applied Concepts Marketing, Inc., USA) certified accurate to $\pm 0.05 \text{ m}\cdot\text{s}^{-1}$ by the manufacturer. The radar gun was placed on a tripod and situated behind protective netting directly in line with the stumps in the position usually occupied by the wicketkeeper.

4.4 Data Reconstruction

All video sequences were downloaded to a Sony VGN-A297XP notebook computer (Sony Corporation, Japan) via an IEEE 1394 interfaced Sony HVR-M15E digital video tape recorder (Sony Corporation, Japan). A Windows®-based Vicon Motus 9.2 software application (Oxford Metrics, UK) was used by an experienced operator to manually coordinate digitise calibration and movement sequences. The zoom function in combination with the sub-pixel cursor was used to increase the measurement resolution from 768×576 to 6144×4608 .

Prior to digitising the 96 movement sequences (12 trials from 8 participants), the centroids of each of the 18 spherical control points were digitised for 10 consecutive fields. Repeated digitisation of each of the control points helped increase the precision

of the calibration coordinate data used to calculate the 11 parameters required to implement the DLT. A user-defined 15-point, 14-segment spatial model was created to represent the human performer (see Appendix B). The centre of the head, the distal end of each foot, and the wrist, elbow, shoulder, hip, knee and ankle centres on both sides of the body were digitised. The centre of the ball was also digitised. The centre of mass of each participant for each trial was also determined using the method of Winter (2005). As no superficial skin markers were used, relevant anatomical knowledge was applied to estimate joint centres of rotation (Plagenhoef, 1971). For each movement sequence, every video field was digitised from 10 fields before back foot impact to 10 fields after ball release. These additional digitised fields provided padding data to overcome any potential end-point problems associated with data conditioning (Smith, 1989; Vint & Hinrichs, 1996). In addition to the 96 movement sequences, one movement sequence (trial 2 from participant 7) was randomly selected and re-digitised 12 times to enable measurement error to be estimated.

Once digitisation of calibration and movement sequences was complete, the two-dimensional image coordinates were converted to three-dimensional object space coordinates using DLT. As noted above, the DLT algorithm requires 11 parameters of which 6 define the location and orientation of the camera and the remaining 5 define the internal characteristics of the digitiser system. The equations for DLT are usually presented as follows:

$$u + \Delta u = \frac{L_1x + L_2y + L_3z + L_4}{L_9x + L_{10}y + L_{11}z + 1} \quad v + \Delta v = \frac{L_5x + L_6y + L_7z + L_8}{L_9x + L_{10}y + L_{11}z + 1} \quad (4.1)$$

where: u and v are the digitised image coordinates; Δu and Δv are the errors associated with the digitised image coordinates; x , y and z are the three-dimensional locations of the digitised points; and $L_1 - L_{11}$ are the DLT parameters.

To obtain the three-dimensional object-space coordinates from the digitised two-dimensional image coordinates, equation (4.1) can be rearranged to give two equations for each camera view relating to the three-dimensional object-space coordinates (x , y , z) of each point to its digitised image coordinates:

$$\begin{bmatrix} L_1 - L_9u & L_2 - L_{10}u & L_3 - L_{11}u \\ L_5 - L_9v & L_6 - L_{10}u & L_7 - L_{11}v \\ L'_1 - L'_9u' & L'_2 - L'_{10}u' & L'_3 - L'_{11}u' \\ L'_5 - L'_9v' & L'_6 - L'_{10}v' & L'_7 - L'_{11}v' \end{bmatrix} \begin{bmatrix} x \\ y \\ z \end{bmatrix} = \begin{bmatrix} u - L_4 \\ v - L_8 \\ u' - L'_4 \\ v' - L'_8 \end{bmatrix} \quad (4.2)$$

where: u' and v' are the digitised image coordinates for the second camera; and $L'_1 - L'_{11}$ are the DLT parameters associated with the second camera.

Equation (4.2) represents the equations for the four planes P_i each of the form $a_i x + b_i y + c_i z = d_i$ ($i = 1, 2, 3, 4$). Each equation is normalised by dividing through by $\sqrt{a_i^2 + b_i^2 + c_i^2}$ and a least squares solution (x_o, y_o, z_o) to the system of the four equations is obtained for each digitised anatomical landmark. The residuals r_i of the least squares solution took the form:

$$|r_i| = \frac{|a_i x_o + b_i y_o + c_i z_o - d_i|}{\sqrt{a_i^2 + b_i^2 + c_i^2}} \quad (i = 1, 2, 3, 4) \quad (4.3)$$

which is the distance of (x_o, y_o, z_o) from the plane P_i . The average RMS residual error estimates for the control points were $0.0023 \times 0.0015 \times 0.0018$ m for the x, y, z axes, respectively, (see Appendix C).

Since the digital video camcorders had no genlocking facility and, therefore, synchronisation of the electronic shutters was not possible, the two sets of two-dimensional image coordinates obtained from digitising each view of the movement sequence were synchronised using the method described by Yeadon and King (1999). Briefly, the root mean square (RMS) distance r of each 3D location from the four planes was calculated using equation (4.4):

$$r = \sqrt{\frac{r_1^2 + r_2^2 + r_3^2 + r_4^2}{4}} \quad (4.4)$$

The RMS distance was calculated for each anatomical landmark digitised in each field throughout the whole delivery from back foot impact to ball release. To

obtain an overall RMS error estimate for each trial over all points and fields the global RMS distance R was calculated using equation (5):

$$R = \sqrt{\frac{\sum_{j=1}^n \sum_{i=1}^{15} r_{ij}^2}{15n}} \quad (4.5)$$

where: r_{ij} is the RMS distance r for anatomical landmark i in field j ; n is the number of video fields; and 15 is the number of digitised anatomical landmarks per video field.

The global RMS distance represents an overall error estimate of the reconstruction error of all the digitised body landmarks and will tend to be smallest when the digitised data sets are correctly synchronised, since all other errors will be the same or similar for different time offsets (Yeadon and King, 1999). Two digitised data sets were, therefore, synchronised by varying the time offset between them until the global RMS distance was minimised. The global RMS distance for the digitised movement sequences ranged from 0.0080 – 0.0122 m (see Appendix C).

4.5 Data Processing

Prior to implementing the various complex analyses, it was necessary to remove the errors or noise that had been introduced during data collection and data reconstruction. Measurement errors are an omnipresent and unavoidable feature of any kinematic investigation and must be minimised before differentiation to avoid propagation. A range of smoothing techniques has been cited in the literature including digital filters (e.g., Vaughan, 1982), truncated Fourier series (e.g., Hatze, 1981), and splines (e.g., Wood & Jennings, 1977). It has been claimed that splines represent the smooth nature of human movement while rejecting the normally distributed random noise assumed to be present in the reconstructed three-dimensional object-space coordinates (e.g., McLaughlin, Dillman & Lardner, 1977). A spline consists of a number of polynomial functions that are pieced together at points known as “knots” to produce a continuous function with continuous derivatives (Wood, 1982). As they had previously been advocated by Zernicke, Caldwell and Roberts (1976) and used by Glazier *et al.* (2000) in their three-dimensional kinematic analysis of collegiate fast-medium bowling techniques, cubic splines were selected and applied to the reconstructed three-

dimensional object-space coordinates. The cubic spline algorithm used placed a knot at every data point and polynomial functions were fitted to every three adjacent knots throughout the entire time series. Both McLaughlin *et al.* (1977) and Challis and Kerwin (1987) highlighted some anomalies regarding the use of cubic splines, mainly when attempting to estimate the second derivative, but as acceleration data were not used in the series of empirical studies outlined in this thesis, these issues were considered redundant.

Perhaps more important than the actual type of smoothing technique being adopted is the amount of smoothing applied to each individual time series measurement. In the past, investigators have used previously published cut-off frequencies (e.g., Winter, Sidwall & Hodson, 1974) or fitted by visual inspection (e.g., Vaughan, 1982) but these approaches are generally considered to be unsatisfactory because of their lack of objectivity. Although a number of different methods have been presented in the literature for the 'optimal' smoothing of biomechanical time series data (e.g., Hatze, 1981; Woltring, 1985; Challis, 1999), Giakas and Baltzopoulos (1997) concluded that there is not one best all-purpose method. In the series of empirical studies outlined in this thesis, the method described by Jackson (1979) was used to calculate the optimal number of passes of the cubic spline for each individual time series. This procedure involved, firstly, calculating the average residual difference between raw data and the smoothed data across the time series. Then, the average residual, expressed as a percentage of the range of the original data, was plotted against the number of passes. This part of the procedure was computationally similar to the popular residual analysis method described by Winter (2005). However, to more accurately identify the optimum number of passes for each individual time series, the second derivative of the percentage mean residuals versus number of passes plot was calculated. The optimum number of passes for each individual time series was determined at the point where three consecutive second derivative data points fell below the default prescribed limit (10%).

Chapter V

The Suitability of Manual Coordinate Digitising for Analysing Inter- and Intra- Individual Movement Variability

5.0 Introduction

In Chapter III, the rationale for adopting a multiple single-participant research design in dynamical systems investigations of human movement was outlined. However, the implementation of this type of analysis is only viable when the method of measurement used is sufficiently sensitive to reliably detect: (i) differences between repeated trials of the same movement performed by the same participant (intra-individual variability); and (ii), differences between repeated trials of the same movement performed by different participants (inter-individual variability). Although the recent advent of automated motion capture systems has reduced the amount of random error in kinematic data, there are instances when this technology is not available or its use is precluded (e.g., during competition, outdoors, under water, etc.). On these occasions, the only other empirically verified and readily available method of obtaining limb and torso kinematics is through the use of image-based motion analysis. Here, movement sequences are filmed using one (for a two-dimensional analysis) or more (for a three-dimensional analysis) digital video cameras, manually coordinate digitised and reconstructed, usually through the use of a direct linear transformation routine (see Chapter IV).

Despite the need to establish the reliability of kinematic data generated using manual coordinate digitising and also to quantify other sources of variation (e.g., intra- and inter-individual variability) contained within this data, there have been few systematic investigations that have focused on either of these issues. Salo and Grimshaw (1998) analysed the variability of kinematic variables that were considered to be related to performance in sprint hurdling. They considered total variance of a single variable to be the sum of the variance of three sources: between-participant (3 males and 4 females), within-participant over repeated trials ($n = 8$) and re-digitisation ($n = 8$ for one male and one female). For the majority of the 28 kinematic variables analysed (15 and 24 for males and females, respectively), the highest portion of variability was found in between-participant variation and the lowest from re-digitising variation. Moreover, the mean coefficient of variation (%CV) for the re-digitisations of the male and female trial was 9.1% and 9.5%, respectively, with 10 and 13 variables having a %CV of less than 1%. It was concluded that, when considered together, these results indicated that the operator and motion analysis system combination used in that study produced sufficiently reliable values for most kinematic variables used to analyse sprint hurdling.

More recently, there has been some conjecture in the literature about whether manual coordinate digitising is suitable for analysing intra-individual movement

variability, particularly as this aspect of motor performance has become a more important research topic in its own right. Bartlett *et al.* (2006) compared two-dimensional kinematic data obtained from an essentially planar motor skill (treadmill running) with and without superficial markers across repeated digitisations, repeated performance trials and different operators. Using ANOVA and omega-squared to partition variance, they reported that, when markers were used, movement variability accounted for a substantial portion of the total variance, more so than random error. However, when no markers were used, the proportion of total variance accounted for by movement variability reduced, mainly because of a concurrent increase in the amount of random error introduced. Based on these findings, Bartlett *et al.* (2006) concluded that intra-individual movement variability could not be reliably determined by manually coordinate digitising movement sequences without superficial skin markers.

Since the study of Bartlett *et al.* (2006), several other investigations have produced results that seemingly contradict their findings. As a precursor to their comparison of single-participant and group-based analyses of cricket fast bowling, Salter *et al.* (2007) reported that the variability of repeated digitisations of a single performance trial (measurement error) was less than the variability of digitisations of repeated performance trials from the same participant (intra-individual movement variability), leading them to conclude that manual coordinate digitising was sufficiently reliable not to influence the results of their study. This finding was surprising given that data collection in their single-participant analysis took place in a competitive match, so consistent and unambiguous identification of anatomical landmarks would have invariably been compromised by clothing worn by the bowler.

Bradshaw, Keogh, Hume, Maulder, Nortje and Marnewick (2009) also reported that measurement error was less than the intra-individual movement variability exhibited by golfers of different abilities over repeated trials. However, they erroneously calculated measurement error from digitisations of repeated performance trials from the same participant not repeated digitisations of the same performance trial from the same participant (Glazier, 2011). A further issue with this study is that siliconCOACH® Pro (siliconCOACH, Dunedin, NZ) was used to generate kinematic data. This semi-quantitative video analysis package not only has a comparatively low digitising resolution owing to there being no sub-pixel cursor but also its reconstruction routine is based on simple linear scaling, which has been shown to be inferior to direct linear transformation procedures (Brewin & Kerwin, 2003). When considered

cumulatively, these methodological issues call into question the validity of the results of Bradshaw *et al.* (2009).

Owing to the apparent discrepancies in the studies reviewed above and because it should be an important aspect of any biomechanical investigation, the purpose of this study was to establish the reliability of manual coordinate digitising when quantifying intra- and inter-individual variability in cricket fast bowlers. As dynamical systems analyses are reliant on time-continuous data sets, the reliability of kinematic measurements over the entire time course of delivery was analysed, in addition to time-discrete performance parameter measurements that are typically reported in more conventional biomechanical investigations.

5.1 Method

The study sample, experimental protocol, data collection, data reconstruction and data processing procedures adopted in the studies outlined in this chapter are detailed in sections 4.1, 4.2, 4.3, 4.4 and 4.5, respectively.

5.1.1 Data Analysis – Time-Discrete Data

The definitions of the time-discrete performance parameters used in this study can be found in Appendix D. These performance parameters were selected because they had either featured previously in the scientific literature on cricket fast bowling performance or had been referred to in the cricket coaching literature. To increase the precision with which key performance parameters could be identified, especially those that occurred between video fields, each of the linear and angular displacement time series measurements were interpolated using a cubic spline to produce continuous time histories. The precise identification of these performance parameters was further expedited by analysing displacement time series data in conjunction with viewing video and stick figure sequences. Mean and standard deviations (SD) for each of the performance parameters over the 12 trials performed by 8 bowlers and the 12 re-digitisations of trial 2 performed by bowler 7 were calculated. Coefficient of variation (%CV) was also calculated to establish the reproducibility of the bowlers' performance and the repeatability of the operator-digitising system combination. %CV was calculated as follows:

Summary statistics, including means, SDs, mean %CVs for individual participants and re-digitisations, can be found in section 5.2.1 and full data sets can be found in Appendix D.

Generalizability theory (Cronbach, Nageswari, & Gleser, 1963) was used to quantify different sources of variation in the data. This approach has been used previously in exercise science and physical therapy research (e.g., Stamm & Moore, 1980; Looney, Smith & Srinivasan, 1990; Roebroeck, Harlaar & Lankhorst, 1993) and can be regarded as an extension of classical test theory and the intraclass correlation coefficient (e.g., Goodwin, 2001). After Salo and Grimshaw (1998), total variance (V) was considered to be the sum of three components (or facets as they are more commonly known in generalizability theory):

$$V = e_b^2 + e_w^2 + e_r^2 \quad (5.2)$$

where: e_b^2 is the variance between participants; e_w^2 is the variance with repeated trials within a participant; and e_r^2 is the variance of the re-digitisations.

The facet variances were estimated as follows:

$$e_b^2 = (1/n) \cdot (MS_b - MS_w) \quad (5.3)$$

$$e_w^2 = MS_w \quad (5.4)$$

$$e_r^2 = V_r \quad (5.5)$$

where: n is the number of trials within a participant (12 in this study); MS_b is the mean square variance (variance of the individual participant means from the grand mean) between participants obtained from the ANOVA; MS_w is the mean square variance (variance of individual scores from the mean score for each participant) within a participant obtained from the ANOVA; and V_r is the variance (squared standard deviation) for the 12 re-digitisations of trial 2 performed by participant 7.

Manual coordinate digitising was deemed to be suitable for analysing movement variability if e_b^2 and e_w^2 were greater than e_r^2 . ANOVA Minitab printouts can be found in Appendix F.

5.1.2 Data Analysis – Time-Continuous Data

The smoothed x, y and z displacement data for each of the 15 digitised anatomical landmark for each of the 12 trials performed by participant 7 were interpolated and time normalised to 101 data points with back foot impact and ball release representing 0% and 100%, respectively. The SD at each of the 101 data points across the 12 repeated performance trials for each of the 45 variables was then calculated. The average SD across the 101 data points was then calculated for each variable to obtain an estimate of intra-individual movement variability. The same analysis procedure was also applied to the 12 re-digitisations of trial 2 performed by participant 7 to obtain an estimate of measurement error.

5.2 Results

5.2.1 Reliability of Time-Discrete Data

The mean \pm SD for 33 time-discrete performance parameters for each participant are shown in Tables 5.1 to 5.4 (see Appendix E for full data sets). The mean %CVs for performance parameters across the 8 participants ranged from 0.6 to 99.5%. There were 28 performance parameters that exhibited less than 10% variation of which 22 of these exhibited less than 5%CV. The remaining 5 performance parameters all exhibited over 10%CV.

The %CV for the re-digitisations ranged from 0.2 to 108.6% with a mean %CV of 6.3% across all 33 time-discrete performance parameters. When potentially problematic performance parameters over 10%—caused, at least in part, by low denominator (mean) values—were excluded, the mean %CV for the remaining performance parameters decreased to 2.1%. There were 27 performance parameters that exhibited less than 5%CV in the re-digitisations of which 13 of these exhibited less than 1%CV.

Table 5.1. Summary mean \pm SD statistics for 5 selected performance parameters at BFI over 12 performance trials for 8 participants and 12 re-digitisations (rd) of trial 2 by participant 7. Also shown is the mean %CV across the 8 participants and %CV for the 12 re-digitisations (see Appendix D for full data sets).

Performance parameter	Participant								Mean %CV	%CV (rd)	
	1	2	3	4	5	6	7	8			rd
Upper Torso Alignment (°)	210.1 \pm 3.62	228.4 \pm 5.16	221.1 \pm 3.94	237.4 \pm 4.39	238.6 \pm 6.41	235.4 \pm 4.61	242.1 \pm 4.34	235.7 \pm 4.81	236.3 \pm 1.01	2.0 \pm 0.32	0.4
Pelvis Alignment (°)	180.5 \pm 1.78	191.3 \pm 3.73	201.6 \pm 5.70	194.5 \pm 7.59	189.8 \pm 1.71	189.1 \pm 5.66	173.5 \pm 2.85	176.9 \pm 2.24	175.6 \pm 1.57	2.1 \pm 1.08	0.9
Back Foot Alignment (°)	316.1 \pm 5.98	338.2 \pm 6.73	340.7 \pm 3.97	342.0 \pm 3.55	313.7 \pm 3.75	340.9 \pm 4.26	242.8 \pm 2.97	287.2 \pm 4.39	239.3 \pm 2.33	1.4 \pm 0.36	1.0
COM Horizontal Velocity (m.s ⁻¹)	5.49 \pm 0.153	5.13 \pm 0.160	5.64 \pm 0.174	5.44 \pm 0.149	5.40 \pm 0.147	5.08 \pm 0.172	4.05 \pm 0.169	3.48 \pm 0.182	3.84 \pm 0.065	3.4 \pm 0.88	1.7
Trunk Flexion-Extension (°)	-4.0 \pm 2.62	-1.2 \pm 1.61	-13.7 \pm 1.76	-5.7 \pm 1.91	4.4 \pm 1.75	-13.3 \pm 1.39	-10.9 \pm 1.44	-16.6 \pm 1.77	-10.4 \pm 0.75	-30.0 \pm 51.3	7.2

Table 5.2. Summary mean \pm SD statistics for 8 selected performance parameters at FFI for 12 performance trials for 8 participants and 12 re-digitisations (rd) of trial 2 by participant 7. Also shown is the mean %CV across the 8 participants and %CV for the 12 re-digitisations (see Appendix D for full data sets).

Performance parameter	Participant								Mean %CV	%CV (rd)	
	1	2	3	4	5	6	7	8			rd
Upper Torso Alignment (°)	193.6 \pm 2.80	229.3 \pm 4.99	217.3 \pm 6.72	198.3 \pm 2.49	200.2 \pm 1.70	202.1 \pm 3.91	188.5 \pm 2.45	200.5 \pm 3.34	188.0 \pm 1.58	1.7 \pm 0.69	0.8
Pelvis Alignment (°)	222.9 \pm 5.66	249.5 \pm 3.74	232.0 \pm 8.18	221.8 \pm 6.14	237.6 \pm 3.14	230.1 \pm 4.18	205.9 \pm 4.45	215.3 \pm 5.43	199.3 \pm 2.95	2.3 \pm 0.72	1.2
Front Knee Angle (°)	167.9 \pm 2.77	158.1 \pm 2.77	157.5 \pm 3.19	162.3 \pm 3.24	164.8 \pm 1.92	159.2 \pm 1.78	174.1 \pm 2.96	159.2 \pm 2.89	175.4 \pm 1.77	1.7 \pm 0.34	1.0
COM Horizontal Velocity (m.s ⁻¹)	4.00 \pm 0.149	4.64 \pm 0.140	4.49 \pm 0.264	4.02 \pm 0.203	4.19 \pm 0.133	3.74 \pm 0.173	3.09 \pm 0.133	2.34 \pm 0.193	3.14 \pm 0.09	4.8 \pm 1.71	2.9
Trunk Flexion-Extension (°)	9.9 \pm 1.52	8.0 \pm 1.92	0.4 \pm 2.05	1.9 \pm 1.81	5.6 \pm 2.29	13.2 \pm 2.00	12.7 \pm 1.81	8.7 \pm 1.71	10.9 \pm 1.08	99.5 \pm 193.0	9.9
Trunk Lateral Flexion (°)	72.0 \pm 1.63	67.2 \pm 1.57	70.0 \pm 3.79	68.4 \pm 2.04	74.4 \pm 1.25	74.4 \pm 1.33	64.8 \pm 1.27	70.3 \pm 1.86	67.1 \pm 0.85	2.6 \pm 1.21	1.3
Non-Bowling Arm to Horizontal (°)	-55.3 \pm 4.48	-79.0 \pm 5.11	-85.9 \pm 7.38	-67.5 \pm 4.04	-57.7 \pm 3.79	-86.3 \pm 5.00	-57.8 \pm 3.39	-78.5 \pm 3.63	-56.1 \pm 1.13	-6.5 \pm 1.29	-2.0
Bowling Arm to Horizontal (°)	-10.0 \pm 4.44	11.4 \pm 5.79	9.8 \pm 8.00	-10.6 \pm 5.22	5.5 \pm 3.01	6.8 \pm 3.62	4.4 \pm 3.21	3.7 \pm 5.27	-0.5 \pm 0.55	45.1 \pm 63.7	-108.6

Table 5.3. Summary mean \pm SD statistics for 5 selected performance parameters at BR for 12 performance trials for 8 participants and 12 re-digitisations (rd) of trial 2 by participant 7. Also shown is the mean %CV across the 8 participants and %CV for the 12 re-digitisations (see Appendix D for full data sets).

Performance parameter	Participant								Mean %CV	%CV (rd)	
	1	2	3	4	5	6	7	8			rd
Height of Ball Release (m)	1.854 \pm 0.042	1.930 \pm 0.036	1.782 \pm 0.029	1.700 \pm 0.041	1.995 \pm 0.021	1.687 \pm 0.023	1.677 \pm 0.062	1.801 \pm 0.023	1.7 \pm 0.00	2.0 \pm 0.84	0.2
Trunk Flexion-Extension (°)	37.0 \pm 2.593	26.2 \pm 3.035	34.4 \pm 2.097	39.7 \pm 3.277	24.4 \pm 2.812	42.7 \pm 3.594	40.6 \pm 2.300	38.6 \pm 1.158	41.9 \pm 0.29	7.7 \pm 2.92	0.7
Front Knee Angle (°)	156.6 \pm 8.28	134.0 \pm 4.41	179.6 \pm 10.66	163.1 \pm 8.339	133.6 \pm 3.35	182.6 \pm 1.82	184.2 \pm 3.77	166.2 \pm 5.11	184.9 \pm 2.05	3.5 \pm 1.75	1.1
COM Horizontal Velocity (m.s ⁻¹)	3.07 \pm 0.229	2.87 \pm 0.193	2.63 \pm 0.135	1.61 \pm 0.115	2.91 \pm 0.099	1.74 \pm 0.127	1.55 \pm 0.126	1.23 \pm 0.092	1.48 \pm 0.09	6.6 \pm 1.56	6.0
Trunk Side Flexion-Extension (°)	50.5 \pm 1.724	60.7 \pm 2.219	45.6 \pm 1.851	47.0 \pm 3.996	56.7 \pm 1.571	54.4 \pm 2.694	47.4 \pm 2.851	57.3 \pm 1.06	50.3 \pm 1.27	4.4 \pm 2.09	2.5

Table 5.4. Summary mean \pm SD statistics for 15 selected performance parameters (from BFI to BR) for 12 performance trials for 8 participants and 12 re-digitisations (rd) of trial 2 by participant 7. Also shown is the mean %CV across the 8 participants and %CV for the 12 re-digitisations (see Appendix D for full data sets).

Performance parameter (Other)	Participant											
	1	2	3	4	5	6	7	8	rd	Mean %CV	%CV (rd)	
Delivery Stride Length (m)	1.347 \pm 0.046	1.547 \pm 0.050	1.553 \pm 0.052	1.490 \pm 0.033	1.288 \pm 0.046	1.345 \pm 0.047	1.338 \pm 0.026	1.341 \pm 0.026	1.3 \pm 0.01	2.9 \pm 0.73	0.5	
Delivery Stride Alignment (°)	170.8 \pm 1.35	171.9 \pm 0.85	179.1 \pm 0.60	181.1 \pm 0.93	173.5 \pm 0.80	174.1 \pm 1.19	174.7 \pm 1.30	167.9 \pm 1.08	174.0 \pm 0.28	0.6 \pm 0.16	0.2	
Max. Right Hip Speed (m.s ⁻¹)	5.92 \pm 0.265	6.05 \pm 0.205	6.13 \pm 0.236	5.58 \pm 0.128	6.05 \pm 0.128	5.13 \pm 0.218	4.51 \pm 0.123	3.68 \pm 0.146	4.3 \pm 0.07	3.4 \pm 0.88	1.6	
Max. Right Shoulder Speed (m.s ⁻¹)	7.98 \pm 0.115	8.13 \pm 0.125	8.90 \pm 0.161	7.78 \pm 0.179	7.88 \pm 0.113	8.35 \pm 0.220	6.88 \pm 0.181	7.00 \pm 0.162	6.6 \pm 0.04	2.0 \pm 0.52	0.6	
Max. Right Wrist Speed (m.s ⁻¹)	20.04 \pm 0.330	19.00 \pm 0.369	20.76 \pm 0.241	20.05 \pm 0.446	20.18 \pm 0.132	21.22 \pm 0.393	18.73 \pm 0.416	19.03 \pm 0.349	17.9 \pm 0.05	1.7 \pm 0.54	0.3	
Max. Pelvis-Upper Torso Separation Angle (°)	33.4 \pm 5.72	26.3 \pm 3.60	15.6 \pm 3.62	26.6 \pm 3.89	38.3 \pm 3.01	28.5 \pm 2.69	25.1 \pm 4.37	15.3 \pm 4.99	18.5 \pm 6.30	17.0 \pm 7.95	34.1	
Min. Upper Torso Alignment (°)	181.4 \pm 1.35	199.2 \pm 3.40	191.1 \pm 2.19	188.4 \pm 3.15	188.3 \pm 0.92	184.6 \pm 2.06	180.3 \pm 1.31	185.2 \pm 1.49	182.9 \pm 0.72	1.0 \pm 0.45	0.4	
Min. Pelvis Alignment (°)	179.9 \pm 1.57	190.3 \pm 2.67	189.2 \pm 2.45	191.1 \pm 4.19	190.6 \pm 2.80	185.6 \pm 2.01	171.9 \pm 3.07	176.1 \pm 1.42	173.1 \pm 1.61	1.4 \pm 0.47	0.9	
Max. Pelvis Angular Velocity (rad.s ⁻¹)	10.89 \pm 0.812	9.59 \pm 1.719	10.43 \pm 0.733	10.32 \pm 0.968	9.03 \pm 1.069	10.55 \pm 0.949	12.46 \pm 0.777	9.70 \pm 1.241	12.0 \pm 0.74	10.2 \pm 3.86	6.2	
Max. Upper Torso Angular Velocity (rad.s ⁻¹)	23.03 \pm 1.147	18.54 \pm 1.123	23.19 \pm 0.596	19.81 \pm 1.175	21.57 \pm 1.088	23.96 \pm 1.324	26.70 \pm 1.330	21.08 \pm 0.920	25.6 \pm 0.60	4.9 \pm 1.11	2.3	
Max. Trunk Angular Velocity (rad.s ⁻¹)	5.27 \pm 0.361	3.74 \pm 0.363	6.24 \pm 0.353	7.00 \pm 0.617	4.03 \pm 0.324	6.68 \pm 0.395	5.72 \pm 0.341	6.14 \pm 0.273	5.6 \pm 0.24	6.9 \pm 1.79	4.2	
Max. Vertical Velocity of Non-Bowling Arm Elbow (m.s ⁻¹)	-6.79 \pm 0.139	-6.58 \pm 0.178	-6.15 \pm 0.323	-5.87 \pm 0.198	-6.72 \pm 0.199	-5.99 \pm 0.373	-5.90 \pm 0.149	-7.07 \pm 0.172	-5.7 \pm 0.06	-3.4 \pm 1.49	-1.0	
Trunk Flexion-Extension ROM (°)	41.3 \pm 2.275	28.2 \pm 4.816	48.0 \pm 2.147	45.5 \pm 4.022	26.2 \pm 2.310	56.8 \pm 1.340	52.3 \pm 2.714	55.5 \pm 2.042	52.4 \pm 0.84	7.0 \pm 4.68	1.6	
Pelvis ROM (°)	89.7 \pm 4.946	76.0 \pm 2.136	90.5 \pm 3.662	73.2 \pm 5.552	76.9 \pm 2.45	85.4 \pm 4.52	88.5 \pm 2.32	74.2 \pm 7.24	88.5 \pm 3.97	5.1 \pm 2.51	4.5	
Upper Torso ROM (°)	126.7 \pm 3.80	117.3 \pm 6.24	144.6 \pm 4.35	111.9 \pm 4.97	108.6 \pm 3.62	126.2 \pm 7.58	127.2 \pm 7.83	114.6 \pm 5.48	129.4 \pm 0.74	4.5 \pm 1.29	0.6	

When expressed as a percentage of total variance, there were 29 performance parameters that exhibited re-digitisation variances of less than 5% of which 15 of these exhibited less than 1% (see Figure 5.1). The re-digitisation variance was greater than the within-participant variance for the maximum pelvis-upper torso separation angle and the within-participant variance was greater than the between-participant variance for the maximum pelvis angular velocity. Of the 33 variables, therefore, 31 exhibited between-participant variances and re-digitisation variances that accounted for the largest and smallest portions of total variance, respectively.

5.2.2 Reliability of Time-Continuous Data

A comparison of measurement error and intra-individual movement variability for each of the 15 anatomical sites in the x, y and z axes is shown in Figure 5.2. The range of the average SD for re-digitisations and repeated movement sequences was 1.4-6.9 mm and 7.5-44.9 mm, respectively, and the mean average SD across the 45 time series was 3.4 mm and 24.5 mm, respectively. When expressed as a percentage of movement variability for the same variable, measurement error, on average, accounted for 17.2% and ranged from 4.3-41.0%.

5.3 Discussion

The recent application of dynamical systems theory to the study of human motor performance has prompted biomechanists to explore alternative research designs and methodologies. As this theoretical framework emphasises the need to measure and analyse coordination and control both within and between participants over repeated performance trials, multiple single-participant research designs are being increasingly used. However, for this approach to produce valid results, the method of analysis needs to be sufficiently sensitive to reliability detect differences within and between participants—that is, it needs to be able to distinguish between inter- and intra-individual movement variability and measurement error. As it is important that researchers implement the appropriate checks prior to their main analysis, the purpose of this study was to establish the reliability of manual coordinate digitising when quantifying intra- and inter-individual variability in cricket fast bowlers.

Because the analytical tools of dynamical systems theory typically rely on the analysis of entire time series measurements, this study examined the reliability of time-

(see [Table 1](#)) to total variance for 33 time-discrete performance parameters. Full datasets can be found in Appendix F.

0



X 00

80 00

L0 00

3 00
(LULU) Q S QBBJQAV

00 00

CM 00

T 00

X	>	N	T	X	1	X	Right Shoulder	0	0	0	0	0	0	0	0	0	0	0
	>	N		X	1	X	Right Shoulder	■	X	1	X	■	X	1	X	■	X	1
		N		X	1	X	Right Shoulder	■	X	1	X	■	X	1	X	■	X	1
		N		X	1	X	Right Shoulder	■	X	1	X	■	X	1	X	■	X	1
		N		X	1	X	Right Shoulder	■	X	1	X	■	X	1	X	■	X	1
		N		X	1	X	Right Shoulder	■	X	1	X	■	X	1	X	■	X	1
		N		X	1	X	Right Shoulder	■	X	1	X	■	X	1	X	■	X	1
		N		X	1	X	Right Shoulder	■	X	1	X	■	X	1	X	■	X	1
		N		X	1	X	Right Shoulder	■	X	1	X	■	X	1	X	■	X	1
		N		X	1	X	Right Shoulder	■	X	1	X	■	X	1	X	■	X	1
		N		X	1	X	Right Shoulder	■	X	1	X	■	X	1	X	■	X	1
		N		X	1	X	Right Shoulder	■	X	1	X	■	X	1	X	■	X	1
		N		X	1	X	Right Shoulder	■	X	1	X	■	X	1	X	■	X	1
		N		X	1	X	Right Shoulder	■	X	1	X	■	X	1	X	■	X	1
		N		X	1	X	Right Shoulder	■	X	1	X	■	X	1	X	■	X	1
		N		X	1	X	Right Shoulder	■	X	1	X	■	X	1	X	■	X	1
		N		X	1	X	Right Shoulder	■	X	1	X	■	X	1	X	■	X	1
		N		X	1	X	Right Shoulder	■	X	1	X	■	X	1	X	■	X	1
		N		X	1	X	Right Shoulder	■	X	1	X	■	X	1	X	■	X	1

g...M landmarks).

continuous measurements in addition to the time-discrete measurements that are habitually used in many biomechanical investigations. The results from the reliability analysis of time-discrete data showed that for the vast majority of performance parameters (31 out of 33), between-participant variance accounted for the largest portion of total variance and re-digitisation variance accounted for the smallest portion. Indeed, only the re-digitisation variance for the maximum hip-shoulder separation angle was greater than the within-participant variance. Several studies (e.g., Stockill & Bartlett, 1996; Elliott, Wallis, Sakurai, Lloyd, & Besier, 2002) have previously shown the accurate determination of this performance parameter to be potentially problematic, mainly because of errors introduced into shoulder alignment measurements, even with the use of external markers. In this study, however, it appears that the magnitude of errors were similar, if not, greater in hip alignment measurements compared to shoulder alignment measurements, as exemplified by greater re-digitisation variances and %CVs for other performance parameters related to hip alignment (i.e., hip axis range of motion and maximum hip axis angular velocity). Because both the shoulder and hip joints are large articulating structures, it can be difficult to precisely determine segmental alignments throughout delivery, which may have implications for accurately establishing causative links between bowling technique and lower back injury (see Elliott, 2000). The strategic positioning of additional cameras, as used, for example, by Burnett *et al.* (1995), could help increase the precision of digitised coordinates for shoulder and hip joint centres but they would also require proportionally greater manual coordinate digitising.

The results from the reliability analysis of the time- continuous measurements showed that variability in the re-digitisations of trial 2 performed by participant 7 (measurement error) for the 45 variables was considerably less than the variability over 12 repeated trials performed by the same participant (intra-individual movement variability). Indeed, when expressed as a percentage of movement variability for the same variable, measurement error, on average, accounted for only 17.2%. Interestingly, the left shoulder and left hip exhibited the largest amounts of error, which was likely to be due to these anatomical landmarks getting occluded from camera view during the period between FFI and BR. The increased errors in the left shoulder and left hip are likely to be responsible, at least in part, for the greater re-digitisation variances and %CVs exhibited in the time-discrete shoulder and hip alignments. These findings further support the recommendation made above for the use of additional strategically placed cameras, although given that the measurement errors were relatively small in

comparison to movement variability, the camera configuration and operator-digitising system combination used in this study was deemed to be sufficiently reliable to produce valid results.

5.4 Conclusion

The results of this study showed that the operator-digitising system combination used was sufficiently sensitive to reliably detect differences in kinematics both within and between individuals over repeated performance trials for the majority of the performance parameters analysed. In terms of the implications beyond this study, this finding suggests that manual coordinate digitising might be an appropriate method for obtaining kinematic data in multiple single-participant analyses. However, owing to the labour intensive nature of the digitising process and the increased likelihood of random errors being introduced during the various stages of data collection, data reconstruction and data processing, it is advisable to use marker-based automated motion capture systems where feasible. Although these systems are not without limitation (see Milner, 2008), they have been shown to have greater accuracy (e.g., Richards, 1999) and will markedly reduce processing time enabling more time-continuous data sets to be collected, at a greater temporal resolution, from a greater number of participants.

Chapter VI

Analysing Cricket Fast Bowling Techniques using Kohonen Self-Organising Maps

6.0 Introduction

Much has been made in the cricket coaching literature recently about preserving individuality in fast bowling and not ‘cloning’ fast bowlers to adopt the same, perceived ‘perfect’, style of bowling technique (e.g., Cooley, 2003, 2005; Pont, 2006). A similar argument against the ‘one size fits all’ approach has also been made in the scientific literature with some authorities calling for the ‘common optimal movement pattern’ or ‘idealised motor template’ concept (Brisson & Alain, 1996), which has typically been based on the action of a champion performer, an averaged profile, or the technique advocated in the coaching literature, to be abandoned (e.g., Davids, Glazier, Araújo & Bartlett, 2003; Schöllhorn, Beckmann, Michelbrink, Sechelmann, Trockel & Davids, 2006; Davids, Button & Bennett, 2008; Schöllhorn, Mayer-Kress, Newell & Michelbrink, 2009; Phillips, Davids, Renshaw & Portus, 2010). Instead, it has been argued that individual-specific coordination solutions should be accepted, and even encouraged, as each fast bowler attempts to satisfy the constantly-changing confluence of organismic, environmental and task constraints impinging on them in the best way possible (Newell, 1986).

In this chapter, a study examining individual differences in fast bowling techniques at a global whole-body level is described. As noted in Chapters II and III, sports biomechanists have not typically analysed the coordinative movement patterns of cricket fast bowlers but have tended to focus on time-discrete kinematic variables that are thought to be related to the performance outcome. This state of affairs has transpired, at least in part, because sports biomechanists have not had access to, or have been unable to implement, analytical techniques capable of handling the high dimensionality of data required to examine sports techniques. The recent introduction of Kohonen Self-Organising Maps (SOMs) in movement science, however, appears to provide a solution to this issue as they enable high-dimensional input data to be compressed on to a low-dimensional map whilst preserving the topological characteristics of the original data (see Figure 6.1). Although this particular artificial neural network has been frequently used in analyses of gait (e.g., Schöllhorn *et al.*, 2002; Barton *et al.*, 2006; Janssen *et al.*, 2008; Janssen, Schöllhorn, Newell, Jäger, Rost & Vehof, 2011), it has featured only sparingly in biomechanical investigations of sports techniques and has yet to be applied to kinematic analyses of cricket fast bowling techniques.

The aims of this study were, therefore, to: (i) establish the magnitude and origin

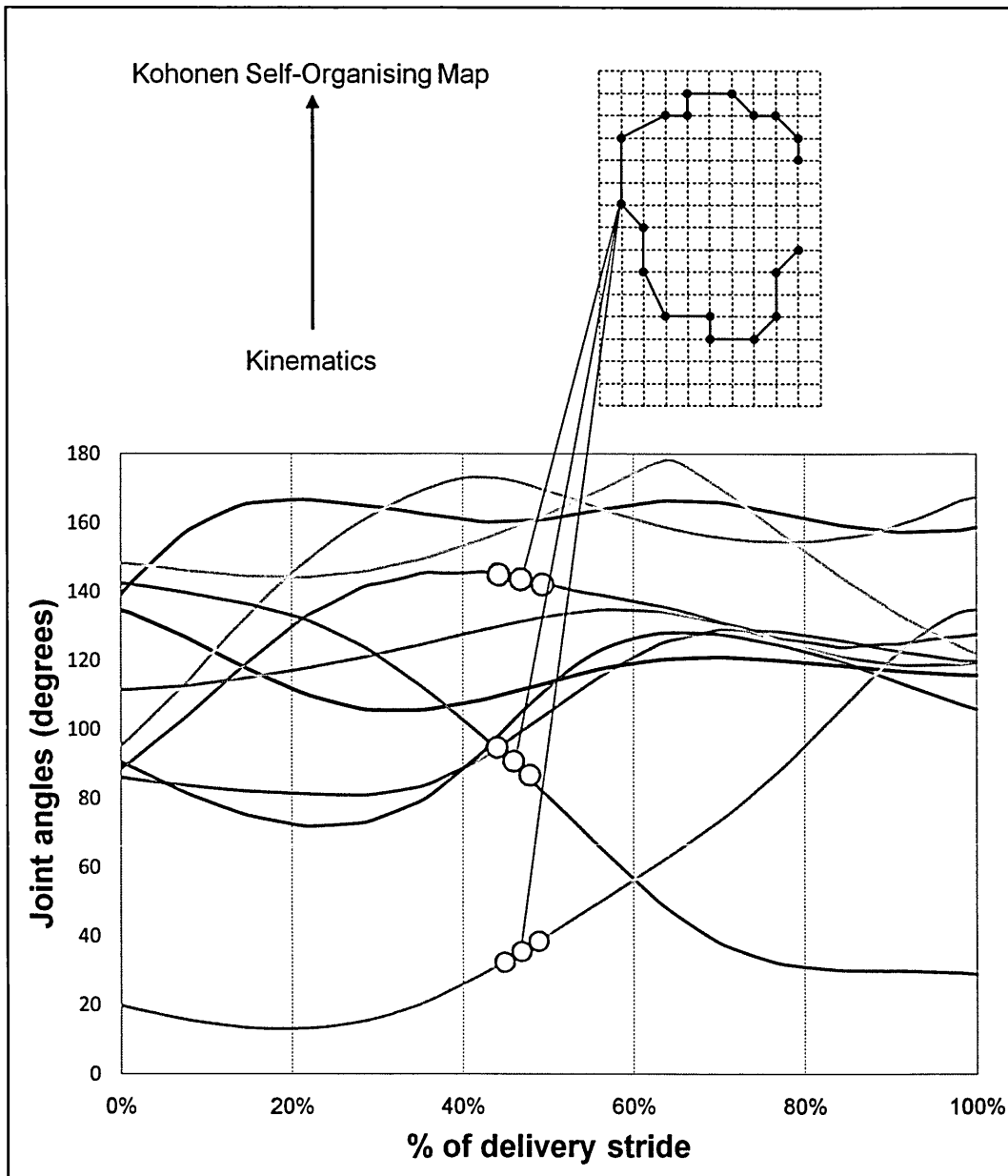

Figure 6.1. A schematic showing the compression of high-dimensional input kinematics (joint angles) acquired from a cricket fast bowler between back foot impact (0%) and ball release (100%) on to a low-dimensional grid of map units or neurons, known as a Kohonen Self-Organising Map (SOM). Owing to its non-linear properties, the abstract 2D SOM trajectory has removed redundancies in, but retained the essential topological characteristics of, the original 3D data set. The SOM displayed in this diagram is a simplified version for illustrative purposes.

of individual differences in fast bowling techniques using SOMs against a dynamical systems theoretical backdrop; and (ii), further explore the potential of SOMs for examining sports techniques at a global whole-body level of analysis using fast bowling as a representative task vehicle. Based on the theoretical arguments provided by Newell (1985), it was anticipated that there would be broad similarities among, but distinctive differences between, the techniques used by individual fast bowlers.

6.1 Method

The study sample, experimental protocol, data collection, data reconstruction and data processing procedures adopted in the studies outlined in this chapter are detailed in sections 4.1, 4.2, 4.3, 4.4 and 4.5, respectively.

6.1.1 Data Analysis

In total, data from 96 movement sequences (12 repeated trials from 8 participants) were presented to the SOM algorithm written in the SOM Toolbox (v. 2.0) running on Matlab R2006b (Vesanto, Himberg, Alhoniemi & Parhankangas, 2000). The SOM Toolbox is freely available and can be downloaded from the following website address: <http://www.cis.hut.fi/projects/somtoolbox/>. Matlab input code can be found in Appendix G.

Time-normalised, three-dimensional joint angles for the ankles, knees, hips, shoulders and elbows from back foot impact (0%) to ball release (100%) were used as inputs. These variables were selected because, together, they provided a reasonable description of limb and torso movements during delivery (Lees & Barton, 2005) and because they were unaffected by variations in anthropometry. Following the generic recommendation of Kohonen (2001), all joint angle time series were linearly scaled so that the variance of each was equal to one, thus ensuring that the SOM was not dominated by a single variable.

To maintain the temporal characteristics of the inputs, data triplets corresponding to t , $t + 5\%$, and $t + 10\%$ for each of the 10 time series were constructed (Barton *et al.*, 2006; Lamb, Bartlett, Robins & Kennedy, 2008). The data triplets were entered into the SOM toolbox as follows:

[Time = 1%], [Time = 6%], [Time = 11%]
[Time = 2%], [Time = 7%], [Time = 12%]
[Time = 3%], [Time = 8%], [Time = 13%]

[Time = 90%], [Time = 95%], [Time = 100%]

As each data triplet effectively spanned 10 data points, the number of data samples acting as inputs was reduced from 100 to 90. In total, 259,000 data points (96 trials x 30 input variables (3 data triplets x 10 joint angles) x 90 data samples) were presented to

the SOM algorithm, which was a similar number of data points to those used by Lamb *et al.* (2008).

Default parameter settings were used to initialise and train the SOM. Linear initialisation was used to organise the weights of the neurons linearly along the two dimensions of the map based on the largest eigenvectors of the inputs. The dimensions of the SOM were determined automatically based on the ratio between the two largest eigenvalues of the covariance matrix of the inputs (Vesanto *et al.*, 2000). For the dataset used in this study, the map size was 27×17 neurons. A hexagonal local lattice structure was applied to define neighbourhoods and connect adjacent neurons.

The batch training algorithm, which calculated the Euclidean distance to all neurons for all input vectors simultaneously, was then implemented. Two training phases were used – a rough training phase followed by a fine-tuning phase. In the former, a relatively large initial neighbourhood training radius and learning rate were used but these were reduced in the latter.

A unified distance matrix or U-matrix was used to visualise the distance between adjacent nodes in the SOM and identify clusters. The high values of the U-matrix (red and yellow colours) indicate a cluster border. Both individual and average SOM trajectories were superimposed onto the U-matrix for each participant. The frequency with which individual neurons were activated was also denoted by the diameter of each neuron, with a greater diameter indicating a greater number of activations.

6.2 Results

U-matrices for each of the 8 participants are shown in Figure 6.2. The narrow white lines in each U-matrix represent SOM trajectories for the 12 individual trials, whereas the thick white line represents an average SOM trajectory based on the 12 individual trials. All SOM trajectories start in the top right-hand quadrant of the U-matrices and work their way downwards or anti-clockwise.

Qualitative evaluation of the U-matrices indicate similarities in the overall shape and path of the average SOM trajectory between participants 1 and 4, participants 2 and 3, and participants 6 and 8.

6.3 Discussion

6.3.1 Magnitude and Origin of Individual Differences

The results of this study showed marked individual differences in the techniques used by fast-medium bowlers who were relatively homogenous in terms of their ball release speeds. Although this finding does not prove conclusively that a common optimal movement pattern for fast bowling does not exist—one might exist but none of the bowlers that were analysed adopted it—it seems unlikely given the distinctive differences in technique between bowlers. These findings are consistent with those reported for javelin throwing by Schöllhorn and Bauer (1998), which has been suggested to be biomechanically similar to cricket fast bowling (e.g., Bartlett *et al.*, 1996). They reported great diversity in the techniques of international javelin throwers, more so, in fact, than in the techniques of national javelin throwers.

Although there were similarities between certain participants, the shape and path of the SOM trajectories for cricket fast bowling were generally less well-defined than those previously reported, for example, by Barton *et al.* (2006) for walking gait. This finding was somewhat surprising given that Newell (1985) argued: “... the natural nominal categorization of activities is determined by the invariant characteristics of the relative motions of the body and limbs. Indeed, by elaboration, it may be proposed that each physical activity is defined behaviorally by a unique set of topological properties of relative motions” (p. 298). When the results of this study are considered in conjunction with those of other studies published in the literature, it could be argued that the relative motion of the limb and torso might be less well-defined in ontogenetic activities (i.e., artificial and stylistic skills that tend to be socially- and culturally-driven) such as cricket bowling than they are for phylogenetic activities (i.e., those that are indigenous and fundamental to the survival of the human species) such as walking and running.

Having established that there is unlikely to be a common optimal movement pattern for cricket fast bowling, it is necessary to consider the origins of the individual differences among the bowlers. As outlined in various sections of this thesis, a central tenet of dynamical systems theory applied to motor control, learning and performance is that coordination patterns emerge from the confluence of interacting task, environmental and organismic constraints that impinge on individual movement systems (Newell, 1986). Therefore, as the bowlers performed under approximately the same task constraints (bowlers were required to bowl each delivery at a pre-defined

target at their 'normal' bowling speed) and environmental constraints (the atmospheric and surface conditions remained constant for each delivery) during data collection, it is reasonable to conclude that any individual differences in technique was due to varying organismic constraints, including the structural constraints arising from the design and architecture of the musculoskeletal system (e.g., Shemmell *et al.*, 2004).

The coordination patterns exhibited by each individual bowler were also likely to have been shaped, at least in part, by the intrinsic dynamics that each individual bowler uniquely possesses. Intrinsic dynamics were defined by Corbetta and Vereijken (1999) as the "... spontaneous coordination tendencies or preferred modes of coordination that exist in the movement system at the start of the learning process. In other words, intrinsic dynamics capture the initial state of the organism when faced with a new learning or developmental task, reflecting the history of the system and prior experiences that contribute to form the existing behavioural repertoire" (p. 511). Kelso (1995) argued that, rather than acquiring a completely new coordination pattern, motor learning involves the moulding and sculpting of pre-existing coordination tendencies that define the intrinsic dynamics to match the task dynamics. From this perspective, intrinsic dynamics will invariably play a role in shaping coordination patterns, although their influence may diminish over time, especially if other constraints, such as instructional constraints (e.g., Newell & Ranganathan, 2010) issued by the coach or other sociocultural constraints (e.g., Clark, 1995), predominate during the learning process.

6.3.2 *Utility and Practical Application of SOMs*

The results of this study provide further evidence that SOMs are an effective analytical tool for capturing topological differences in sports techniques between individuals, which supports the findings of previous studies where SOMs have been used to analyse discus throwing (Bauer & Schöllhorn, 1997), javelin throwing (Schöllhorn & Bauer, 1998), football kicking (Lees & Barton, 2005) and basketball throwing (Lamb, Bartlett & Robins, 2010). However, it is necessary to consider the practical application of SOMs, specifically how they can be used by sports biomechanists in an applied coaching or pedagogical context to help improve technique and performance.

Perhaps the most obvious application, and one that has been alluded to in the literature, is using SOMs in a diagnostics (i.e., fault finding or error detection) capacity. For SOMs to be used in this manner, however, researchers and practitioners need to be

able to identify the SOM trajectory that corresponds to the ‘normal’, ‘correct’ or ‘optimal’ technique so that the SOM trajectories obtained from specific individuals can be compared to it. In gait analysis, some researchers have used an averaging process to generate baseline normative profiles (e.g., Barton, Lisboa, Lees & Attfield, 2007; Barton, Hawken, Scott & Schwartz, 2010). Although this approach might be viable when comparing healthy individuals with those exhibiting moderate to severe injury, disease or disability, it is unlikely to be appropriate when attempting to evaluate the gaits of healthy individuals or the techniques of sports performers. For example, even the gaits of normal individuals have been shown to be influenced by emotions and music (Janssen *et al.*, 2008). As noted in section 3.2.2, by pooling group data in this way, individual differences can get obscured and an average ‘mythical’ profile (i.e., one that is not representative of any individual in that group) is often generated (e.g., Gregor, 1989; Michaels & Beek, 1996; James & Bates, 1997). Indeed, as Kelso (1995) warned: “Because each person possesses his or her own ‘signature’, it makes little sense to average performance over individuals. One might as well average apples and oranges.” (p. 161).

As the distinctive individual differences reported in this and other studies (e.g., Schöllhorn & Bauer, 1998; Schöllhorn *et al.*, 2002; Janssen *et al.*, 2008) indicate that a ‘common optimal movement pattern’ or ‘idealised motor template’ towards which the majority of performers should aspire to achieve is unlikely to exist, it is necessary to identify the correct or optimal movement pattern for specific individuals. However, as Hay (1983) noted, claims that sports biomechanists can identify optimal movement solutions for specific individuals are “science fiction not science fact” (p. 18) and, although advancements have been made in optimisation modelling since the 1980s, it is still not possible to establish individual-specific coordination solutions for the vast majority of sports skills (see section 3.2.5 for an elaboration). This issue would appear not only to be a significant barrier to the more widespread application of SOMs in an applied context, but also for sports biomechanists, more generally, in their attempts to improve performance and reduce injury (Bartlett, 1997). As recommended by Glazier and Davids (2009b), further work is needed in optimisation modelling of sports techniques to discover optimal movement solutions for specific individuals, which is likely to involve incorporating a greater range and uniqueness of constraints in models of the neuromusculoskeletal system and simulation process.

A possible solution to the problem of not being able to identify individual-specific optimal movement solutions, at least in the short-term, might be to generate SOM trajectories for a best performing trial for specific individuals and use that as a basis for detecting faults in technique by comparing all other performance trials to it. In this way, each performer has his or her own reference which can be used as a basis for technical evaluation and to direct remedial action when performing poorly (Gregor *et al.*, 1992). Although not ideal given the amount and often functional nature of intra-individual movement variability apparent in sport techniques and the fact that the same outcome can be produced by different coordination patterns (Davids *et al.*, 2003), this strategy appears to be the best option currently available to sports biomechanists. However, a further issue that threatens to compromise the effectiveness of SOMs when used in this capacity is the difficulty of linking characteristics of SOM trajectories to specific aspects of technique. This problem has been identified previously by Lees (2002) among others but has yet to be satisfactorily resolved. Indeed, as Bartlett (2006) cautioned: “If the mapping rules within these opaque and very non-linear networks never come transparent, as some experts in artificial neural networks predict, then explicit mappings between specific features of the kinematic time series and the output maps may never emerge” (p. 15). Clearly, much work is to be done in this area.

6.4 Conclusion

This study provides further evidence suggesting that ‘common optimal movement patterns’ or ‘idealised motor templates’ in sport are unlikely to exist, thus supporting the findings from other studies with a similar focus (e.g., Schöllhorn & Bauer, 1998). It also demonstrates that SOMs are an effective tool for capturing individualities in technique or movement signatures. However, the utility of SOMs is undermined by the fact that optimal coordination patterns and, therefore, optimal SOM trajectories for specific individuals performing sports techniques cannot currently be determined. The practical application of SOMs is further compromised by the difficulty in linking aspects of technique with specific features of the SOM trajectory. These factors, combined with their computational and conceptual complexity, may explain why SOMs have not been more widely used in biomechanical analyses of sports techniques. Further research is required to resolve these issues if SOMs are going to become a more useful and versatile tool for sports biomechanists in an applied context.

Chapter VII

Relationships between Intersegmental Coordination and Ball Release Speed: A Multiple Single-Participant Analysis

7.0 Introduction

A key theoretical concept, yet to be fully explored in cricket fast bowling, but integral to many throwing, kicking and striking activities, is the 'kinematic chain' (Atwater, 1979; Bartlett & Robins, 2008; Elliott, Alderson & Reid, 2008). This phenomenon is defined as a proximal-to-distal linkage system through which energy and momentum are transferred sequentially, achieving maximum magnitude in the terminal segment (Fleisig, Barrentine, Escamilla & Andrews, 1996). Although several studies have empirically verified the kinematic chain in fast bowling (e.g., Elliott *et al.*, 1986; Stockill & Bartlett, 1994; Glazier *et al.*, 2000), it is still unclear how the movements of the pelvis, upper torso, bowling arm, non-bowling arm and front leg are coordinated to facilitate energy and momentum transfer. This apparent lack of understanding may, in part, be due to the methods used by investigators to examine body segment dynamics. For example, previous studies have merely described the kinematic chain in terms of the peak resultant velocities (Elliott *et al.*, 1986) and the peak horizontal velocities (Glazier *et al.*, 2000) of upper extremity body segments endpoints. Although these procedures clearly provide evidence of a progressive proximal-to-distal increase in segmental velocities, neither study reported the temporal occurrence of peak segment endpoint velocities in relation to ball release, therefore, providing an insufficient description of temporal sequencing in fast bowling. However, even with the inclusion of corresponding time histories as reported, for example, by Stockill and Bartlett (1994), identical peak segment endpoint velocities may be generated by completely different acceleration profiles, providing little information about segmental interactions and energy transfer.

To gain a better understanding of proximal-to-distal sequencing in cricket fast bowling and how energy and momentum might effectively be transferred along the kinetic chain, it is necessary to examine how body segments interact during delivery. As indicated above, an alternative approach to reducing time series data to discrete kinematic measurements and their corresponding time histories is required as this procedure fails to capture the dynamic nature of the movement (e.g., Baumann, 1992). As a precursor to more sophisticated kinetic and energetic analyses, segmental interactions could be examined by analyzing sets of time series data obtained from adjacent body segments or joints using so-called 'complex' analytical techniques that have emerged from dynamical systems investigations of human movement (e.g., Hamill *et al.*, 2000; Kurz & Stergiou, 2004; Wheat & Glazier, 2006). As noted in section 3.2.6,

these techniques, unlike inverse dynamics analyses and energetic analyses, do not require kinematic data to be combined with body segment inertia parameters or ground reaction force data, they make fewer assumptions, and they can be used to quantify relative motion information on which athletes and coaches have been shown to base their subjective judgements of sports techniques (e.g., Sparrow & Sherman, 2001).

As ‘complex’ analytical techniques derived from dynamical systems theory have seldom been applied beyond studies of human locomotion and because coordination in cricket fast bowling has yet to be investigated in any form, the aims of this study were to: (i) demonstrate the utility and application of various ‘complex’ analytical techniques (i.e., cross-correlation functions and vector coding) to cricket fast bowling by using them to quantify the intersegmental coupling relationships between various upper and lower extremity body segments; (ii) identify whether any systematic differences in these coupling relationships existed between individual fast bowlers; and (iii), establish whether there was any association between these coupling relationships and ball release speed both within and between fast bowlers.

7.1 Method

The study sample, experimental protocol, data collection, data reconstruction and data processing procedures adopted in the studies outlined in this chapter are detailed in sections 4.1, 4.2, 4.3, 4.4 and 4.5, respectively.

7.1.1 Data Analysis

Angular displacements for the bowling arm, non-bowling arm, front leg, upper torso and pelvis throughout the course of the delivery stride were calculated using the definitions described in Figure 7.1. Each time series was interpolated using a cubic spline and time normalised to 101 data points with back foot impact (BFI) and ball release (BR) representing 0% and 100%, respectively. Relative motion diagrams or angle-angle plots were constructed for the following segment couplings: non-bowling arm vs. front leg (NBA vs. FL); bowling arm vs. non-bowling arm (BA vs. NBA); bowling arm vs. front leg (BA vs. FL); and upper torso vs. pelvis (UT vs. P). These couplings were selected because: (i) they are all either integral to the kinematic chain or are likely to be instrumental in facilitating the transfer of energy and momentum along the kinematic chain through force coupling; and (ii), because they had previously been

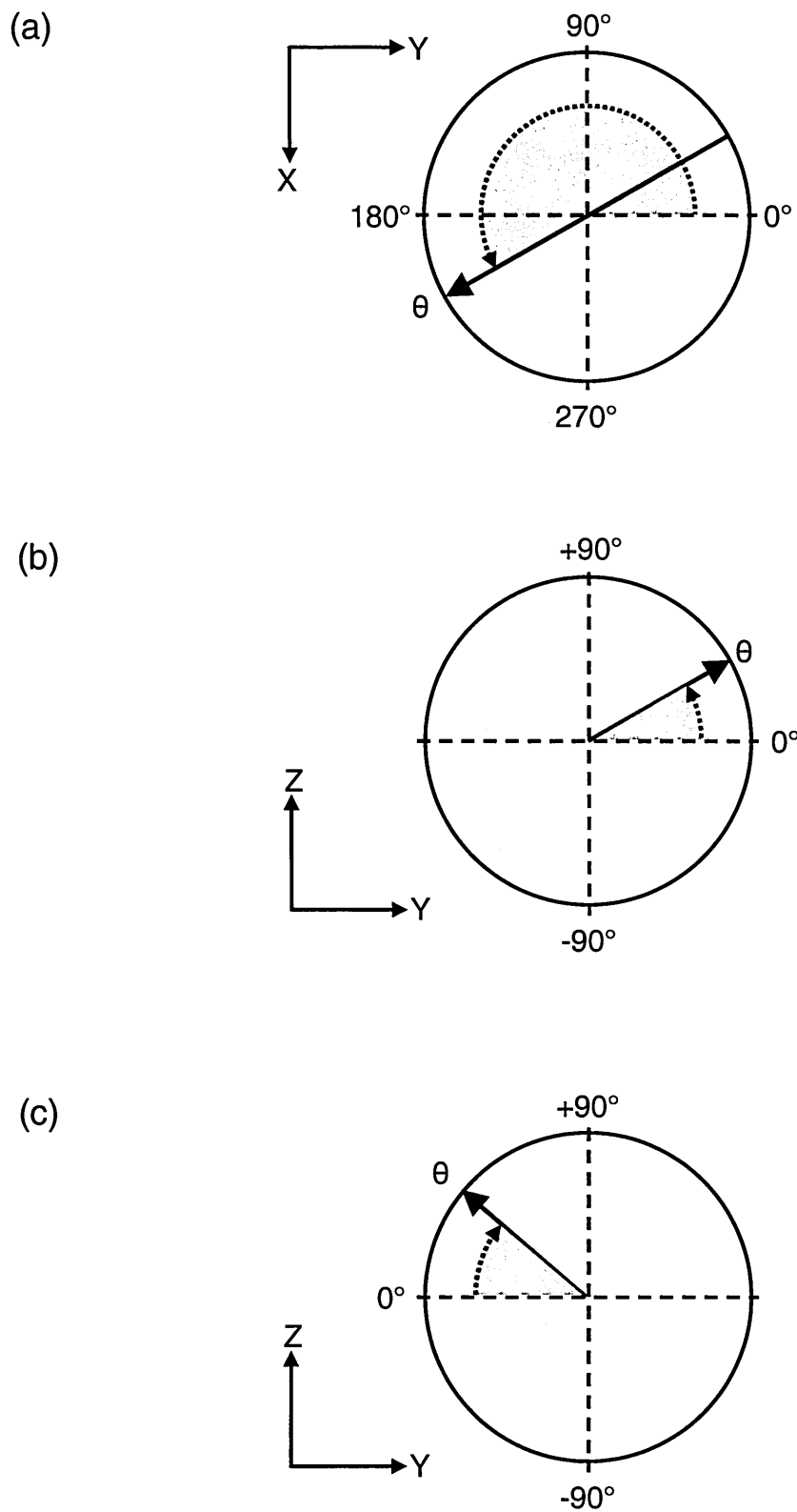

Figure 7.1. Segment angular displacement definitions for: (a) upper torso and pelvis (centred mid-segment); (b) non-bowling arm and front leg (centred on proximal end of each segment); and (c) bowling arm (centred on proximal end of the segment).

identified in the scientific (e.g., Davis & Blanksby, 1976b) and coaching (e.g., Pont, 2006) literatures on fast bowling as being potentially important in the generation of high ball release speeds. The proximal and distal segments comprising each coupling—defined functionally in terms of their position in the kinematic chain rather than anatomically—were plotted on the abscissa and ordinate axis, respectively (see Figure 7.2).

A combination of analytical techniques, as adopted by Pohl and Buckley (2008), was used to analyse the data displayed in the angle-angle plots. Cross-correlation functions (e.g., Derrick & Thomas, 2004) were used to establish the type of coupling relationship, the degree of linkage and the phase relation between the segments comprising each coupling. A positive peak cross-correlation coefficient indicated an in-phase coupling relationship, a negative peak cross-correlation coefficient indicated an anti-phase coupling relationship, and the magnitude of the peak cross-correlation coefficient indicated the strength of the coupling relationship (Temprado *et al.*, 1997). The phase relation between segments was established by shifting the time series data from one segment backward or forward in relation to the time series data of the other segment by a given number of data points. As a general rule, Derrick and Thomas (2004) recommended $n/2$ offsets but they suggested that the type (e.g., circular or non-circular) and length of the time series need to be considered. On visual inspection of the time series data comprising each coupling, it was deemed that 20 time offsets were appropriate. A peak cross-correlation coefficient found at a negative time lag indicated that the proximal segment moved before the distal segment, whereas a peak cross-correlation coefficient found at a positive time lag indicated the distal segment moved before the proximal segment. Peak cross-correlation coefficients found at a zero time lag indicated that the two segments moved synchronously.

One of the limitations of cross-correlation functions is that they only provide an indication of the temporal similarity between, and not the relative magnitudes of, the two time series presented in angle-angle plots (Pohl & Buckley, 2008). For example, it is possible for two pairs of time series measurements to have similar peak cross-correlation coefficients but have quite different amplitudes and ratio. To overcome this issue, vector coding (Tepavac & Field-Fote, 2001) was also applied to the angle-angle plots. This technique involved calculating the angle between the vector adjoining consecutive data points on the angle-angle trajectory and the right horizontal (see Figure 7.2a). This angle, known as the coupling angle (γ), ranged from 0 to 360° and provided

the following information: 0° and 180° indicated that the distal segment was stationary while the proximal segment was moving; 90° and 270° indicated that the proximal segment was stationary while the distal segment was moving; 45° and 225° indicated that the two segments were moving at the same rate and in the same direction (i.e., perfectly in-phase); 135° and 315° indicated that the two segments were moving at the same rate but in opposite directions (i.e., perfectly anti-phase) (see Figure 7.2b).

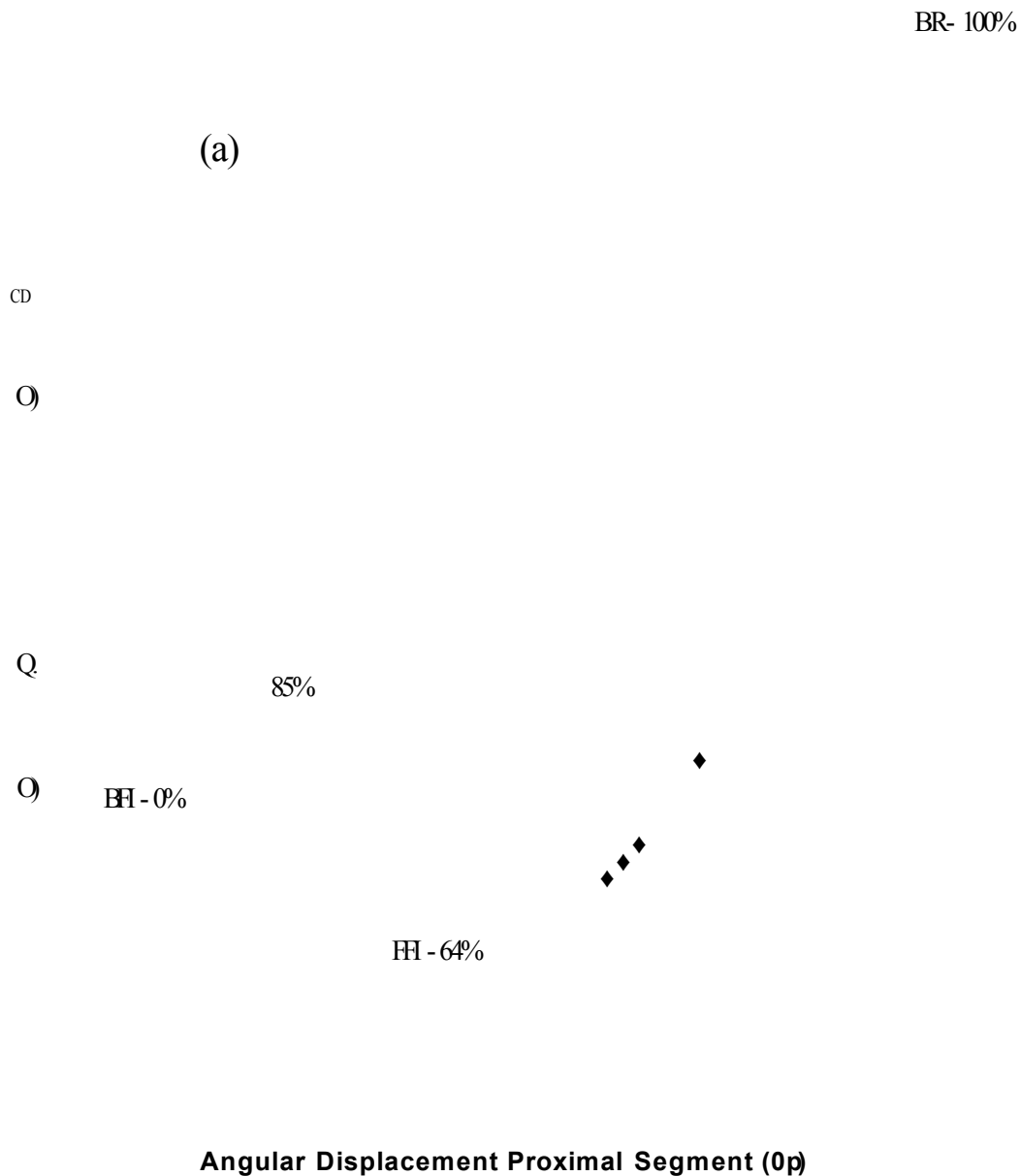

Figure 7.2. Vector coding applied to an exemplar relative motion diagram or angle-angle plot for the UT vs. P coupling. The magnified view (a) indicates how the coupling angle (γ) was calculated at every percentage point from BFI (0%) to BR (100%). The coupling angle compass (b) shows how γ was interpreted with the hashed arrows indicating equal movement in both segments and the solid arrows indicating movement in one segment only.

As it was rare for coupling angles to lie exactly along the vertical, horizontal and 45° diagonals, the 360° coupling angle range was further divided into 45° sectors, with the boundary of each sector falling 22.5° either side of the vertical, horizontal and 45° diagonals (see Table 7.1). The type of coordination was calculated at every percentage point during the delivery stride from BFI (0%) to BR (100%). This method was previously used by Chang, van Emmerik and Hamill (2008) to analyse rearfoot-forefoot coordination in human walking.

Table 7.1. Types of coordination and their coupling angle (γ) boundaries.

Coordination Pattern	Coupling Angle Definition
Anti-phase	$112.5^\circ \leq \gamma < 157.5^\circ, 292.5^\circ \leq \gamma < 337.5^\circ$
In-phase	$22.5^\circ \leq \gamma < 67.5^\circ, 202.5^\circ \leq \gamma < 247.5^\circ$
Proximal phase	$0^\circ \leq \gamma < 22.5^\circ, 157.5^\circ \leq \gamma < 202.5^\circ, 337.5^\circ \leq \gamma \leq 360^\circ$
Distal phase	$67.5^\circ \leq \gamma < 112.5^\circ, 247.5^\circ \leq \gamma < 292.5^\circ$

7.1.2 Statistical Analysis

To identify whether any statistically significant, systematic differences in coordination existed between individual fast bowlers, a one-way analysis of variance (ANOVA) was applied to the cross-correlation coefficients and coupling angle data obtained from each of the 8 participants over 12 performance trials. Prior to performing these tests, however, further manipulations of the cross-correlation and coupling angle data were necessary. With the former, all cross-correlation coefficients calculated for the period between BFI and BR for each segment coupling were Z-transformed using the formula outlined by Fisher (1921). This procedure was necessary because cross-correlation coefficients are not normally distributed—that is, the distribution becomes negatively skewed as the cross-correlation coefficient increases (Silver & Dunlap, 1987). With the latter, the mean coupling angle for each of the four phases (0-24%, 25-49%, 50-74% and 75-99%) of the period between BFI and BR for each segment coupling (NBA vs. FL, BA vs. NBA, BA vs. FL and UT vs. P) was calculated using directional or circular statistics (e.g., Batschelet, 1981).

The Z-transformed cross-correlation coefficients and mean coupling angle data were then formally tested for normality and homogeneity of variance using Anderson-Darling and Levene's tests, respectively. Although one-way ANOVAs have been shown to be robust when data violate the homogeneity of variance assumption, particularly when equal sample sizes are used (e.g., Boneau, 1960), there can be an increase in the Type I error rate under these conditions. Therefore, when groups did not exhibit equal variances, a Welch's *F* test (Welch, 1951) was used, as recommended by Wilcox

(1987), as this test increases power and reduces the likelihood of Type I errors. Omega squared (ω^2) was also calculated to provide an estimate of the proportion of total variance accounted for by the independent variable (Tolson, 1980). The following formulae were used to calculate ω^2 and adjusted ω^2 for group comparisons that exhibited homogenous (7.1) and heterogeneous (7.2) variances, respectively:

$$\omega^2 = \frac{SS_B - (k - 1) \cdot (MS_W)}{SS_T + MS_W} \quad (7.1)$$

where: SS_B is the sum of squares between groups; k is the number of groups (8 in this study); MS_W is the mean square within groups; and SS_T is the total sum of squares.

$$adj. \omega^2 = \frac{df_{bet}(F-1)}{df_{bet}(F-1) + N_T} \quad (7.2)$$

where: df_{bet} is the number of groups (8 in this study) minus one; F is the F statistic derived from Welch's F test; and N_T is the total number of trials across participants (96 in this study).

Tukey's HSD and Games-Howell's *post-hoc* tests were applied when the homogeneity of variance assumption was and was not met, respectively, to make pairwise comparisons between individual participant means and identify where statistically significant differences, if any, existed. The standardised difference statistic, Cohen's d (Cohen, 1988), was also calculated to determine the meaningfulness of statistically significant mean differences between participants (Thomas, Salazar & Landers, 1991). The following formula was used:

$$d = \frac{M_1 - M_2}{SD_{pooled}} \quad (7.3)$$

where: M_1 is the mean of group 1; M_2 is the mean of group 2; and SD_{pooled} is the pooled standard deviation.

The threshold values proposed by Hopkins, Marshall, Batterham and Hanin (2008) for small (0.2), moderate (0.60), large (1.20), very large (2.0) and extremely large (4.0) effects were adopted for interpreting magnitude of effect.

To establish whether there were any associations between segmental coupling relationships and ball release speed, Pearson product-moment correlation coefficients were calculated. The multiple single-participant research design adopted in this study enabled both a cross-sectional and a longitudinal analysis to be undertaken. In the cross-sectional analysis, the peak Z-transformed cross-correlation coefficients for both the best performing trial (the trial that produced the greatest ball release speed) and a mean trial (calculated across the 12 trials at each percentage point between 0-100%) for each participant were correlated with their corresponding ball release speeds (average ball speed in the case of the average trial) across the 8 participants. In the longitudinal analysis, the peak Z-transformed cross-correlation coefficient for each trial was correlated with its respective ball release speed over the 12 trials performed for each of the 8 participants.

A similar analysis was conducted on the coupling angle data. However, instead of correlating ball release speed with the mean coupling angle calculated during the period from BFI to BR for each of the 4 segment couplings, the delivery stride was divided into phases (0-24%, 25-49%, 50-74% and 75-99%) and the mean coupling angle for each phase was calculated. Pearson product-moment correlation coefficients were then calculated for each mean coupling angle for the 4 segment couplings for each phase and ball release speed. As in the cross-correlation analysis, a cross-sectional analysis using both the best performing trial and average trial for each of the 8 participants, and a longitudinal analysis across the 12 trials performed by each participant, was conducted.

As multiple correlation coefficients were calculated for both the cross-correlation and vector coding analyses, the Bonferroni's correction procedure (e.g., Curtin & Schulz, 1998) was used to adjust the level of significance and decrease the risk of Type I errors. This procedure simply involved dividing the alpha level ($\alpha = 0.05$) by the number of tests, which for the cross-correlation and vector coding analysis was 4 (adj. $\alpha = 0.013$) and 16 (adj. $\alpha = 0.003$), respectively. All statistical tests were implemented using SPSS v.17 except the Anderson-Darling tests that were implemented using Minitab v.16.

7.2 Results

This results section is divided into three sub-sections. In sub-section 7.2.1, mean differences in ball release speed among the 8 participants over the 12 performance trials are reported. In section 7.2.2, mean differences in cross-correlation coefficients for the four segment couplings among the 8 participants over the 12 performance trials and statistical associations between cross-correlation coefficients and ball release speed within and between participants are reported. Finally, in section 7.2.3, average differences in mean coupling angle among the 8 bowlers over the 4 phases (0-24%, 25-49%, 50-74% and 75-99%) of the 12 performance trials and any statistical associations between average coupling angle and ball release speed within and between participants are reported.

7.2.1 Ball Release Speed

The ball release speeds for each of the 8 participants over the 12 performance trials are summarised in Table 7.2. Anderson-Darling normality tests showed that 7 out of the 8 data sets obtained from each participant were normally distributed. However, the Levene's test revealed that the homogeneity of variance assumption was not met when testing for differences between participants ($P = 0.011$). A Welch's F test was, therefore, applied to determine statistically significant differences among participants for ball release speed and an adjusted ω^2 statistic was calculated to determine how much of the total variance in ball release speed could be attributed to differences among participants.

The results of the Welch's F test revealed that a statistically significant difference in ball release speed existed between the 8 participants (Welch's $F_{7, 37.12} = 33.85$, $P < 0.001$, adj. $\omega^2 = 0.705$). A Games-Howell *post-hoc* test was used to identify where differences in ball release speed between individual participants existed. The results of this test, along with Cohen's d standardised difference statistics for statistically significant mean differences, are shown in Table 7.3. Of the 28 unique pairwise comparisons, 17 were shown to have significantly different ball release speeds ($P < 0.05$). The mean Cohen's d standardised difference statistic for statistically significant mean differences was 2.92 (range 1.44-5.08). The magnitudes of the statistically significant mean differences were interpreted as being large ($n = 6$), very large ($n = 6$) or extremely large ($n = 5$) according to the criteria set out by Hopkins *et al.* (2008).

Table 7.2. Mean and SD ball release speeds calculated across the 12 deliveries bowled by each of the 8 participants.

Trial	Participant							
	1	2	3	4	5	6	7	8
1	33.06	29.61	30.11	30.56	31.47	30.75	31.39	29.94
2	34.00	30.64	31.75	30.33	31.06	30.83	31.44	28.53
3	33.53	29.06	33.06	30.22	30.50	31.19	31.75	29.72
4	33.14	29.58	33.11	31.72	31.39	31.44	31.31	29.39
5	33.47	29.78	31.31	31.56	31.39	31.53	32.06	29.69
6	34.00	29.33	31.92	31.31	31.39	31.69	32.67	29.31
7	34.00	30.14	32.64	31.14	31.39	31.56	32.39	29.97
8	34.00	30.33	32.44	30.64	30.81	31.33	32.53	30.78
9	34.11	31.61	32.17	30.28	30.92	31.56	33.28	30.64
10	32.31	31.22	32.78	30.50	30.64	31.56	33.22	30.61
11	34.53	29.69	30.22	31.11	30.36	31.33	32.75	30.83
12	34.53	31.14	33.03	31.00	29.78	31.67	33.25	31.25
M	33.72	30.18	32.05	30.86	30.93	31.37	32.34	30.06
SD	0.649	0.817	1.041	0.512	0.530	0.308*	0.739	0.786

* Not normally distributed

Table 7.3. Games-Howell's *post hoc* test results for average ball release speed by participant.

Participant	Mean	Mean Differences ($M_i - M_j$) (Cohen's <i>d</i> statistics are presented in parentheses)						
		1	2	3	4	5	6	7
1	33.72	-	-	-	-	-	-	-
2	30.18	3.55*** (4.80)	-	-	-	-	-	-
3	32.04	1.68** (1.94)	-1.87** (1.99)	-	-	-	-	-
4	30.86	2.86*** (4.89)	-0.69	1.18* (1.44)	-	-	-	-
5	30.93	2.80*** (4.71)	-0.75	1.12	-0.06	-	-	-
6	31.37	2.35*** (4.63)	-1.19** (1.93)	0.68	-0.51	-0.45	-	-
7	32.34	1.39** (1.98)	-2.16*** (2.77)	-0.29	-1.47*** (2.33)	-1.41** (2.19)	-0.97* (1.71)	-
8	30.06	3.67*** (5.08)	0.12	1.99** (2.15)	0.81	0.87	1.32** (2.19)	2.28*** (2.99)

* $P < 0.05$, ** $P < 0.01$, *** $P < 0.001$

7.2.2 Cross-Correlation Analysis

Full datasets for peak phase-lagged cross-correlation coefficients for the 8 participants over the 12 performance trials can be found in Appendix H. Mean (SD) peak phase-lagged cross-correlation coefficients, and their Z-transformed analogues, calculated over the 12 performance trials performed by each of the 8 participants are presented in Tables 7.4 and 7.5, respectively.

Table 7.4. Mean (SD) phase-lagged cross-correlation coefficients calculated over the 12 performance trials performed by each of the 8 participants.

Participant	Mean Lagged Cross-Correlation Coefficient			
	NBA vs. FL	BA vs. NBA	BA vs. FL	UT vs. P
1	0.991 (0.445)	-0.956 (0.078)	-0.934 (0.200)	0.806 (0.109)
2	0.972 (0.483)	-0.978 (0.098)	-0.938 (0.302)	0.792 (0.091)
3	0.647 (0.253)	-0.974 (0.140)	-0.733 (0.361)	0.922 (0.125)
4	0.920 (0.330)	-0.961 (0.061)	-0.937 (0.398)	0.735 (0.113)
5	0.612 (0.168)	-0.978 (0.150)	-0.533 (0.162)	0.690 (0.094)
6	0.990 (0.154)	-0.975 (0.120)	-0.984 (0.149)	0.733 (0.070)
7	0.984 (0.455)	-0.938 (0.078)	-0.980 (0.238)	0.688 (0.109)
8	0.981 (0.357)	-0.973 (0.041)	-0.942 (0.214)	0.717 (0.114)

NB. Mean and SD are backtransformed values.

Table 7.5. Mean (SD) phase-lagged Z-transformed cross-correlation coefficients calculated over the 12 performance trials performed by each of the 8 participants.

Participant	Mean Lagged Z-Transformed Cross-Correlation Coefficient			
	NBA vs. FL	BA vs. NBA	BA vs. FL	UT vs. P
1	2.687 (0.479)	-1.892 (0.078)	-1.692 (0.203)	1.114 (0.109)
2	2.125 (0.527)	-2.257 (0.098)	-1.721 (0.311)*	1.078 (0.092)
3	0.771 (0.258)	-2.174 (0.141)	-0.934 (0.378)	1.606 (0.126)
4	1.592 (0.343)	-1.954 (0.061)	-1.713 (0.421)	0.939 (0.114)
5	0.712 (0.170)	-2.242 (0.044)	-0.595 (0.163)	0.848 (0.094)
6	2.642 (0.155)	-2.194 (0.121)	-2.415 (0.150)	0.934 (0.070)
7	2.419 (0.491)	-1.725 (0.078)	-2.300 (0.243)	0.843 (0.109)*
8	2.314 (0.374)	-2.152 (0.041)	-1.753 (0.217)	0.901 (0.115)
Levene's <i>F</i>	<i>P</i> = 0.005**	<i>P</i> = 0.004**	<i>P</i> = 0.057	<i>P</i> = 0.802
Variance Ratio (H v L)	11.6 : 1	11.8 : 1	7.9 : 1	3.2 : 1

* Not normally distributed, ** Homogeneity of variance assumption violated

Anderson-Darling normality tests showed that 30 out of the 32 Z-transformed cross-correlation coefficient data sets obtained from the 8 participants were normally distributed. However, the Levene's tests revealed that the homogeneity of variance assumption was not met when testing for differences between participants for the following segment couplings: NBA vs. FL ($P = 0.005$) and BA vs. NBA ($P = 0.004$). The Welch's F test was, therefore, applied to determine statistically significant differences among participants for these couplings and an adjusted ω^2 statistic was calculated to determine how much of the total variance could be attributed to differences between participants.

The Welch's F and one-way ANOVA tests of average Z-transformed cross-correlation coefficients showed statistically significant differences between the 8

participants for each of the 4 segment couplings: NBA vs. FL – Welch’s $F_{7, 37.05} = 144.41, P < 0.001, \text{adj. } \omega^2 = 0.913$; BA vs. NBA – Welch’s $F_{7, 37.06} = 58.91, P < 0.001, \text{adj. } \omega^2 = 0.809$; BA vs. FL – $F_{7, 88} = 59.29, P < 0.001, \omega^2 = 0.809$; UT vs. P – $F_{7, 88} = 68.98, P < 0.001, \omega^2 = 0.832$.

Pairwise *post hoc* comparisons, using Games-Howell’s and Tukey’s tests for heterogeneous and homogeneous data sets, respectively, were implemented to identify differences in coupling relationships between participants. The results of these tests are summarised in Tables 7.6 to 7.9 along with Cohen’s *d* standardised difference statistics for statistically significant mean differences. Of the 28 unique pairwise comparisons for the NBA vs. FL, BA vs. NBA, BA vs. FL and UT vs. P segment couplings, 19, 17, 20 and 17, respectively, were shown to be significantly different ($P < 0.05$). The mean Cohen’s *d* standardised difference statistic for the NBA vs. FL, BA vs. NBA, BA vs. FL and UT vs. P couplings were 4.07 (range 1.12-11.86), 3.49 (range 0.44-8.16), 4.10 (range 1.71-11.62) and 3.60 (range 1.37-6.86), respectively. Only 4 of the 73 Cohen’s *d* standardised difference statistics calculated for statistically significant mean differences were less than the 1.2 threshold figure suggested by Hopkins *et al.* (2008) to represent a large effect.

To establish whether there were any associations between segmental coupling relationships and ball release speed within and between participants, Pearson product-moment correlation coefficients were calculated for: (i) peak phase-lagged Z-transformed cross-correlation coefficient and ball release speed for each participant; (ii) the average peak phase-lagged Z-transformed cross-correlation coefficient calculated across the 12 deliveries for each participant and average ball release speed; and (iii) peak phase-lagged Z-transformed cross-correlation coefficient for the best performing trial and corresponding ball release speed for each participant were calculated. The results of these statistical tests can be found in Table 7.10. No statistically significant correlation coefficients ($\text{adj. } P > 0.013$) for segmental coupling relationships and ball release speed could be identified.

Table 7.6. Games-Howell's *post hoc* test results for mean phase-lagged Z-transformed cross-correlation coefficients (NBA vs. FL coupling) by participant.

Participant	Mean Differences ($M_i - M_j$) (Cohen's d statistics are presented in parentheses)							
	1	2	3	4	5	6	7	8
1	2.687							
2	0.562** (1.12)							
3	1.916*** (4.98)	1.354*** (3.26)						
4	1.095*** (2.63)	0.533* (1.20)	-0.821*** (2.71)					
5	1.974*** (5.50)	1.413*** (3.61)	0.058	-0.879*** (3.25)				
6	2.642	-0.518* (1.33)	-1.872*** (8.79)	-1.051*** (3.95)	-1.930*** (11.86)			
7	2.419	-0.294	-1.648*** (4.20)	-0.827*** (1.95)	-1.706*** (4.65)	0.224		
8	2.314	-0.189	-1.543*** (4.80)	-0.722*** (2.01)	-1.602*** (5.51)	0.328	0.105	

* $P < 0.05$, ** $P < 0.01$, *** $P < 0.001$

Table 7.7. Games-Howell's *post hoc* test results for mean phase-lagged Z-transformed cross-correlation coefficients (BA vs. NBA coupling) by participant.

Participant	Mean Differences ($M_i - M_j$) (Cohen's d statistics are presented in parentheses)							
	1	2	3	4	5	6	7	8
1	-1.892							
2	-2.257							
3	-2.174	-0.082						
4	-1.954	-0.302*** (0.44)	-0.221*** (2.03)					
5	-2.242	-0.014	0.068	0.289*** (5.42)				
6	-2.194	-0.063	0.020	0.240*** (2.50)	-0.048			
7	-1.725	-0.531*** (0.76)	-0.449*** (3.94)	-0.228*** (3.27)	-0.517*** (8.16)	-0.469*** (4.61)		
8	-2.152	-0.104	-0.022	0.199* (3.81)	-0.090	-0.042	0.427*** (6.85)	

* $P < 0.05$, ** $P < 0.01$, *** $P < 0.001$

Table 7.8. Tukey's *post hoc* test results for mean phase-lagged Z-transformed cross-correlation coefficients (BA vs. FL coupling) by participant.

Participant	Mean Differences ($M_i - M_j$) (Cohen's d statistics are presented in parentheses)							
	1	2	3	4	5	6	7	8
1	-1.692							
2	-1.721							
3	-0.934	-0.787*** (2.27)						
4	-1.713	-0.008	0.779*** (1.95)					
5	-0.595	-1.127*** (4.54)	-0.340	-1.119*** (3.50)				
6	-2.415	0.694*** (2.84)	1.481*** (5.15)	0.702*** (2.22)	1.820*** (11.62)			
7	-2.300	0.579*** (2.07)	1.366*** (4.30)	0.587*** (1.71)	1.705*** (8.24)	-0.115		
8	-1.753	0.032	0.819*** (2.66)	0.040	1.158*** (6.03)	-0.662*** (3.55)	0.547*** (2.37)	

* $P < 0.05$, ** $P < 0.01$, *** $P < 0.001$

Table 7.9. Tukey's *post hoc* test results for mean phase-lagged Z-transformed cross-correlation coefficients (UT vs. P coupling) by participant.

Participant	Mean Differences ($M_i - M_j$) (Cohen's <i>d</i> statistics are presented in parentheses)							
	1	2	3	4	5	6	7	8
1	1.114							
2	0.037							
3	-0.491*** (4.18)	-0.528*** (4.79)						
4	0.175** (1.60)	0.139* (1.37)	0.667*** (5.58)					
5	0.266*** (2.61)	0.229*** (2.47)	0.757*** (6.82)	0.091				
6	0.180** (1.97)	0.143* (1.76)	0.671*** (6.59)	0.004	-0.086			
7	0.271*** (2.66)	0.234*** (2.53)	0.762*** (6.86)	0.096	0.005	0.091		
8	0.214*** (1.90)	0.177** (1.70)	0.705*** (5.84)	0.038	-0.052	0.034	-0.057	

* $P < 0.05$, ** $P < 0.01$, *** $P < 0.001$

Table 7.10. Pearson product-moment correlation coefficients for: (i) peak phase-lagged Z-transformed cross-correlation coefficients and ball release speed for each participant; (ii) the average peak phase-lagged Z-transformed cross-correlation coefficient calculated across the 12 deliveries for each participant and average ball release speed; and (iii) peak phase-lagged Z-transformed cross-correlation coefficient for the best performing trial and corresponding ball release speed for each participant.

Participant	Pearson Product-Moment Correlation Coefficients (<i>P</i> -values in parentheses)		
	NBA vs. FL	BA vs. NBA	BA vs. FL
1	0.323 (0.306)	-0.033 (0.921)	-0.386 (0.215)
2	-0.104 (0.747)	-0.272 (0.396)	-0.095 (0.770)
3	0.490 (0.106)	-0.263 (0.409)	-0.427 (0.166)
4	0.458 (0.134)	0.321 (0.308)	-0.453 (0.139)
5	0.057 (0.861)	-0.361 (0.249)	-0.083 (0.798)
6	0.123 (0.704)	-0.061 (0.851)	-0.316 (0.250)
7	-0.357 (0.255)	-0.013 (0.969)	-0.294 (0.353)
8	0.223 (0.486)	-0.096 (0.766)	-0.511 (0.090)
Average Trial	0.156 (0.713)	0.579 (0.133)	-0.037 (0.930)
Best Trial	0.517 (0.189)	0.658 (0.076)	-0.188 (0.656)
			UT vs. P
			-0.266 (0.407)
			0.297 (0.347)
			-0.289 (0.362)
			-0.141 (0.662)
			-0.017 (0.958)
			0.219 (0.493)
			-0.433 (0.160)
			-0.093 (0.774)

7.2.2 Vector Coding Analysis

Full datasets for mean coupling angles for the 8 participants over the 12 performance trials can be found in Appendix I. Average mean (SD) coupling angle calculated during the 4 phases (0-24%, 25-49%, 50-74% and 75-99%) of the delivery stride over 12 performance trials for the NBA vs. FL coupling are reported in Table 7.11.

Table 7.11. Average mean (SD) coupling angle calculated during the 4 phases (0-24%, 25-49%, 50-74% and 75-99%) of the delivery stride over 12 performance trials for the NBA vs. FL coupling.

Participant	Average Mean Coupling Angle for NBA vs. FL Coupling (SD in parentheses)			
	0-24%	25-49%	50-74%	75-99%
1	239.4 (8.5)	258.1 (0.7)	262.7 (3.4)	240.8 (9.0)
2	261.1 (7.5)	264.6 (1.3)	266.8 (2.7)*	248.9 (9.1)
3	292.7 (8.9)	266.6 (2.2)	269.3 (3.8)	219.3 (8.6)
4	247.3 (8.4)	267.7 (0.8)	266.2 (3.0)	246.9 (7.5)*
5	261.2 (2.8)	262.2 (1.3)	277.3 (3.1)	240.7 (16.1)
6	242.4 (3.9)*	252.0 (1.5)	254.4 (1.5)	215.3 (13.0)
7	261.4 (10.7)	258.9 (1.2)	251.5 (3.7)	226.4 (14.3)*
8	252.0 (3.7)	261.6 (1.2)	264.4 (1.5)	251.1 (5.0)
Levene's F	$P = 0.012^{**}$	$P = 0.049^{**}$	$P = 0.008^{**}$	$P = 0.008^{**}$
Variance Ratio (H v L)	15.1 : 1	9.1 : 1	6.6 : 1	10.2 : 1

* Not normally distributed, ** Homogeneity of variance assumption violated

Anderson-Darling normality tests showed that 28 out of the 32 mean coupling angle data sets obtained from the 8 participants for the NBA vs. FL coupling were normally distributed. However, Levene's tests revealed that the homogeneity of variance assumption was not met when testing for differences between participants for any of the four phases of the delivery stride: 0-24% ($P = 0.012$), 25-49% ($P = 0.049$), 50-74% ($P = 0.008$) and 75-99% ($P = 0.008$). The Welch's F test was, therefore, applied to determine statistically significant differences among participants for each of these phases and an adjusted ω^2 statistic was calculated to determine how much of the total variance could be attributed to differences between participants.

The Welch's F tests of average mean coupling angle showed statistically significant differences between the 8 participants for each of the 4 phases of the delivery stride for the NBA vs. FL coupling: 0-24% – Welch's $F_{7, 36.99} = 60.96$, $P < 0.001$, adj. $\omega^2 = 0.814$; 25-49% – Welch's $F_{7, 37.38} = 212.64$, $P < 0.001$, adj. $\omega^2 = 0.939$; 50-74% – Welch's $F_{7, 37.20} = 109.15$, $P < 0.001$, adj. $\omega^2 = 0.887$; 75-99% – Welch's $F_{7, 37.26} = 25.75$, $P < 0.001$, adj. $\omega^2 = 0.643$.

Pairwise *post hoc* comparisons using Games-Howell's test was implemented to identify differences in average mean coupling angles between participants. The results of this test are summarised in Tables 7.12 to 7.15 along with Cohen's d standardised

difference statistics for statistically significant mean differences. Of the 28 unique pairwise comparisons for the 0-24%, 25-49%, 50-74% and 75-99% phases of the delivery stride for the NBA vs. FL coupling, the average mean coupling angle was shown to be significantly different ($P < 0.05$) for 20, 24, 19 and 14 pairwise comparisons, respectively. The mean Cohen's d standardised difference statistic for the 0-24%, 25-49%, 50-74% and 75-99% phases were 3.52 (range 1.46-7.34), 5.42 (range 1.85-12.83), 4.59 (range 1.70-9.41) and 2.58 (range 1.42-4.52), respectively. All of the Cohen's d standardised difference statistics calculated for statistically significant mean differences were greater than the 1.2 threshold figure suggested by Hopkins *et al.* (2008) to represent a large effect.

To establish whether there were any associations between segmental coupling relationships and ball release speed within and between participants, Pearson product-moment correlation coefficients for: (i) mean coupling angle for the NBA vs. FL coupling and ball release speed for each participant; (ii) the average mean coupling angle for the NBA vs. FL coupling calculated across the 12 deliveries for each participant and average ball release speed; and (iii) mean coupling angle for the NBA vs. FL coupling for the best performing trial and corresponding ball release speed for each participant were calculated. The results of these statistical tests can be found in Table 7.16. Only one statistically significant correlation coefficient (adj. $P < 0.003$) could be identified and that was between mean coupling angle and ball release speed during the 75-99% phase of the delivery stride for participant 7.

Histograms of the types of coordination exhibited over the 12 performance trials for the NBA vs. FL coupling during the four phases (0-24%, 25-49%, 50-74% and 75-99%) of the delivery stride for each participant are shown in Figure 7.3.

Table 7.12. Games-Howell's *post hoc* test results for average mean coupling angle for the NBA vs. FL coupling (0-24%) by participant.

Participant	Mean Differences ($M_i - M_j$) (Cohen's d statistics are presented in parentheses)							
	1	2	3	4	5	6	7	8
1	239.4							
2	-21.8*** (2.71)	261.1						
3	-53.4*** (6.14)	292.7						
4	-7.9	247.3						
5	-21.8*** (3.45)	261.2	45.5*** (5.26)					
6	-3.0	242.4	31.6*** (4.80)	-13.9** (2.23)				
7	-22.1*** (2.27)	261.4	50.4*** (7.34)	4.9	18.8*** (5.54)			
8	-12.6** (1.93)	252.0	31.3*** (3.18)	-14.2* (1.46)	-0.3	-19.1** (2.35)		
			40.7*** (6.01)	-4.7	9.2*** (2.84)	-9.6*** (2.53)	9.5	

* $P < 0.05$, ** $P < 0.01$, *** $P < 0.001$

Table 7.13. Games-Howell's *post hoc* test results for average mean coupling angle for the NBA vs. FL coupling (24-49%) by participant.

Participant	Mean Differences ($M_i - M_j$) (Cohen's d statistics are presented in parentheses)							
	1	2	3	4	5	6	7	8
1	258.1							
2	-6.5*** (6.25)	264.6						
3	-8.5*** (5.12)	266.6						
4	-9.6*** (12.54)	267.7	-1.1					
5	-4.1*** (3.81)	262.2	4.4*** (2.40)	5.5*** (5.03)				
6	6.1*** (5.05)	252.0	14.6*** (7.62)	15.7*** (12.63)	10.2*** (7.09)			
7	-0.8	258.9	7.7*** (4.28)	8.8*** (8.56)	3.3*** (2.59)	-6.9*** (4.97)		
8	-3.5*** (3.43)	261.6	5.0*** (2.77)	6.1*** (5.87)	0.6	-9.6*** (6.87)	-2.7*** (2.20)	

** $P < 0.01$, *** $P < 0.001$

Table 7.14. Games-Howell's *post hoc* test results for average mean coupling angle for the NBA vs. FL coupling (50-74%) by participant.

Participant	Mean Differences ($M_i - M_j$) (Cohen's d statistics are presented in parentheses)							
	1	2	3	4	5	6	7	8
1	262.7							
2	-4.1	266.8						
3	-6.6** (1.84)	269.3						
4	-3.5	266.2						
5	-14.6*** (4.49)	277.3	3.1					
6	8.3*** (3.18)	254.4	-8.0*** (2.31)	-11.1*** (3.64)				
7	11.2*** (3.15)	251.5	14.9*** (5.20)	11.8*** (5.02)	22.9*** (9.41)			
8	-1.7	264.4	17.8*** (4.75)	14.7*** (4.37)	25.8*** (7.54)	2.9		
			4.9* (1.7)	1.8	12.9*** (5.26)	-10.0*** (6.64)	-12.9*** (4.54)	

* $P < 0.05$, ** $P < 0.01$, *** $P < 0.001$

Table 7.15. Games-Howell's *post hoc* test results for average mean coupling angle for the NBA vs. FL coupling (75-99%) by participant.

Participant	Mean	Mean Differences (M _i - M _j) (Cohen's <i>d</i> statistics are presented in parentheses)							
		1	2	3	4	5	6	7	8
1	240.8	-							
2	248.9	-8.1	-						
3	219.3	21.5*** (2.45)	29.6*** (3.34)	-					
4	246.9	-6.1	-27.6*** (3.43)	-	-				
5	240.7	0.1	-21.4** (1.66)	6.2	-				
6	215.3	25.5*** (2.28)	33.6*** (2.99)	31.6*** (2.98)	25.4** (1.74)	-			
7	226.4	14.4	22.5** (1.88)	4.0	20.5** (1.80)	-11.1	-		
8	251.1	-10.3* (1.42)	-31.8*** (4.52)	-7.1	-4.2	-35.8*** (3.63)	-24.7** (2.31)	-	

* $P < 0.05$, ** $P < 0.01$, *** $P < 0.001$

Table 7.16. Pearson product-moment correlation coefficients for: (i) mean coupling angle for the NBA vs. FL coupling and ball release speed for each participant; (ii) the average mean coupling angle for the NBA vs. FL coupling calculated across the 12 deliveries for each participant and average ball release speed; and (iii) mean coupling angle for the NBA vs. FL coupling for the best performing trial and corresponding ball release speed for each participant.

Participant	Pearson Product-Moment Correlation Coefficient (<i>P</i> -values in parentheses)							
	0-24%	25-49%	50-74%	75-99%				
1	-0.256 (0.423)	0.180 (0.577)	-0.292 (0.357)	0.437 (0.156)				
2	0.301 (0.342)	0.104 (0.746)	0.281 (0.377)	0.117 (0.718)				
3	0.544 (0.067)	-0.212 (0.509)	-0.371 (0.234)	0.046 (0.887)				
4	-0.266 (0.403)	-0.177 (0.586)	-0.337 (0.283)	-0.020 (0.952)				
5	0.294 (0.353)	-0.145 (0.651)	-0.040 (0.901)	0.384 (0.217)				
6	0.604 (0.037)	0.495 (0.103)	0.314 (0.322)	0.194 (0.545)				
7	-0.352 (0.261)	0.127 (0.693)	-0.135 (0.676)	-0.806 (0.002)*				
8	-0.083 (0.798)	0.344 (0.275)	-0.152 (0.637)	-0.403 (0.194)				
Average Trial	-0.024 (0.955)	-0.385 (0.346)	-0.328 (0.427)	-0.465 (0.245)				
Best Trial	-0.026 (0.951)	-0.368 (0.370)	-0.474 (0.2350)	-0.349 (0.396)				

* $P < 0.003$

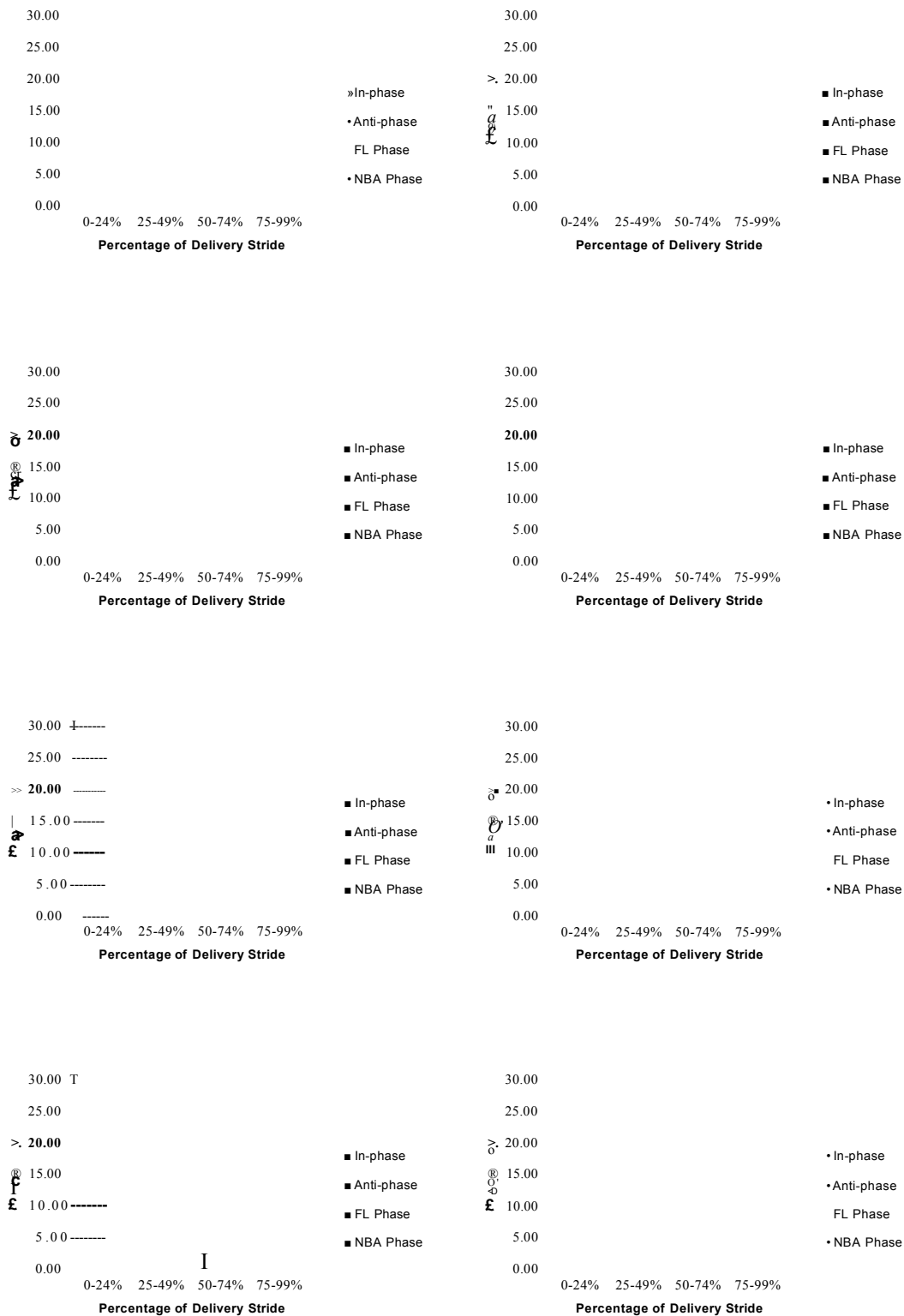

Figure 7.3. Histograms (mean \pm SD) of the types of coordination exhibited over the 12 performance trials for the NBA vs. FL coupling during the four phases (0-24%, 25-49%, 50-74% and 75-99%) of the delivery stride for participant 1 (top left) to 8 (bottom right).

Average mean (SD) coupling angle calculated during the 4 phases (0-24%, 25-49%, 50-74% and 75-99%) of the delivery stride over 12 performance trials for the BA vs. NBA coupling are reported in Table 7.17.

Table 7.17. Average mean (SD) coupling angle calculated during the 4 phases (0-24%, 25-49%, 50-74% and 75-99%) of the delivery stride over 12 performance trials for the BA vs. NBA coupling.

Average Mean Coupling Angle for BA vs. NBA Coupling (SD in parentheses)				
Participant	0-24%	25-49%	50-74%	75-99%
1	132.7 (8.5)	142.6 (1.6)	132.7 (1.8)	99.4 (1.7)
2	122.5 (5.7)	133.6 (1.3)	126.5 (1.8)	99.9 (2.3)
3	121.5 (5.6)	138.3 (1.4)	129.1 (1.5)	102.5 (3.6)
4	126.3 (5.6)	141.7 (2.2)	121.4 (1.4)	102.6 (1.5)
5	130.5 (2.5)	128.0 (1.4)	122.5 (2.1)	96.5 (3.8)
6	132.2 (3.0)*	134.1 (1.3)	126.7 (1.8)	100.1 (3.9)
7	128.3 (6.5)	143.5 (1.2)	122.0 (3.0)	96.4 (2.3)
8	133.1 (3.6)	144.5 (1.7)	131.5 (1.2)	106.3 (1.7)
Levene's F	$P = 0.010^{**}$	$P = 0.608$	$P = 0.066$	$P = 0.048^{**}$
Variance Ratio (H v L)	11.1:1	3.4:1	6.3:1	6.9:1

* Not normally distributed, ** Homogeneity of variance assumption violated

Anderson-Darling normality tests showed that 31 out of the 32 mean coupling angle data sets obtained from the 8 participants for the BA vs. NBA coupling were normally distributed. However, Levene's tests revealed that the homogeneity of variance assumption was not met when testing for differences between participants for the following phases of the delivery stride: 0-24% ($P = 0.010$) and 75-99% ($P = 0.048$). The Welch's F test was, therefore, applied to determine statistically significant differences among participants for each of these phases and an adjusted ω^2 statistic was calculated to determine how much of the total variance could be attributed to differences between participants.

The Welch's F tests of average mean coupling angle showed statistically significant differences between the 8 participants for each of the 4 phases of the delivery stride for the BA vs. NBA coupling: 0-24% – Welch's $F_{7, 37.23} = 9.14$, $P < 0.001$, adj. $\omega^2 = 0.725$; 25-49% – $F_{7, 88} = 172.54$, $P < 0.001$, $\omega^2 = 0.926$; 50-74% – $F_{7, 88} = 62.22$, $P < 0.001$, $\omega^2 = 0.817$; 75-99% – Welch's $F_{7, 37.40} = 27.23$, $P < 0.001$, adj. $\omega^2 = 0.657$.

Pairwise *post hoc* comparisons, using Games-Howell's and Tukey's tests for heterogeneous and homogeneous data sets, respectively, were implemented to identify differences in average mean coupling angles between participants. The results of these tests are summarised in Tables 7.18 to 7.21 along with Cohen's d standardised difference statistics for statistically significant mean differences. Of the 28 unique pairwise comparisons for the 0-24%, 25-49%, 50-74% and 75-99% phases of the delivery stride for the BA vs. NBA coupling, the average mean coupling angle was

shown to be significantly different ($P < 0.05$) for 9, 22, 22 and 13 pairwise comparisons, respectively. The mean Cohen's d standardised difference statistic for the 0-24%, 25-49%, 50-74% and 75-99% phases were 1.94 (range 1.41-2.48), 5.72 (range 1.43-11.77), 3.59 (range 1.58-7.84) and 2.60 (range 1.48-4.93), respectively. All of the Cohen's d standardised difference statistics calculated for statistically significant mean differences were greater than the 1.2 threshold figure suggested by Hopkins *et al.* (2008) to represent a large effect.

To establish whether there were any associations between segmental coupling relationships and ball release speed within and between participants, Pearson product-moment correlation coefficients for: (i) mean coupling angle for the BA vs. NBA coupling and ball release speed for each participant; (ii) the average mean coupling angle for the BA vs. NBA coupling calculated across the 12 deliveries for each participant and average ball release speed; and (iii) mean coupling angle for the BA vs. NBA coupling for the best performing trial and corresponding ball release speed for each participant were calculated. The results of these statistical tests can be found in Table 7.22. No statistically significant correlation coefficients (adj. $P > 0.003$) for segmental coupling relationships and ball release speed could be identified.

Histograms of the types of coordination exhibited over the 12 performance trials for the BA vs. NBA coupling during the four phases (0-24%, 25-49%, 50-74% and 75-99%) of the delivery stride for each participant are shown in Figure 7.4.

Table 7.18. Games-Howell's *post hoc* test results for average mean coupling angle for the BA vs. NBA coupling (0-24%) by participant.

Participant	Mean	Mean Differences ($M_i - M_j$) (Cohen's <i>d</i> statistics are presented in parentheses)							
		1	2	3	4	5	6	7	8
1	132.7	-							
2	122.5	10.2* (1.41)	-						
3	121.5	11.2* (1.56)	1.0	-					
4	126.3	6.4	-3.8	-4.8	-				
5	130.5	2.2	-8.0** (1.80)	-9.0** (2.07)	-4.2	-			
6	132.2	0.5	-9.7** (2.12)	-10.7*** (2.38)	-5.9	-1.7	-		
7	128.3	4.4	-5.8	-6.8	-2.0	2.2	3.9	-	
8	133.1	-0.4	-10.6** (2.21)	-11.6*** (2.48)	-6.8* (1.44)	-2.6	-0.9	-4.8	-

* $P < 0.05$, ** $P < 0.01$, *** $P < 0.001$

Table 7.19. Tukey's *post hoc* test results for average mean coupling angle for the BA vs. NBA coupling (25-49%) by participant.

Participant	Mean	Mean Differences ($M_i - M_j$) (Cohen's <i>d</i> statistics are presented in parentheses)							
		1	2	3	4	5	6	7	8
1	142.6	-							
2	133.6	9.0*** (6.14)	-						
3	138.3	4.3*** (2.79)	-4.7*** (3.48)	-					
4	141.7	0.9	-8.1*** (4.52)	-3.4*** (1.84)	-				
5	128.0	14.6*** (9.46)	5.6*** (4.12)	10.3*** (7.18)	13.7*** (7.39)	-			
6	134.1	8.5*** (5.74)	-0.5	4.2*** (2.93)	7.6*** (4.22)	-6.1*** (4.45)	-		
7	143.5	-0.9	-9.9*** (8.08)	-5.2*** (3.97)	-1.8	-15.5*** (11.77)	-9.4*** (7.57)	-	
8	144.5	-1.9	-10.9*** (7.29)	-6.2*** (3.96)	-2.8** (1.43)	-16.5*** (10.51)	-10.4*** (6.90)	-1.0	-

** $P < 0.01$, *** $P < 0.001$

Table 7.20. Tukey's *post hoc* test results for average mean coupling angle for the BA vs. NBA coupling (50-74%) by participant.

Participant	Mean	Mean Differences ($M_i - M_j$) (Cohen's <i>d</i> statistics are presented in parentheses)							
		1	2	3	4	5	6	7	8
1	132.7	-							
2	126.5	6.2*** (3.49)	-						
3	129.1	3.6*** (2.21)	-2.6* (1.58)	-					
4	121.4	11.3*** (7.14)	5.1*** (3.19)	7.7*** (5.40)	-				
5	122.5	10.2*** (5.22)	4.0*** (2.03)	6.6*** (3.61)	-1.1	-			
6	126.7	6.0*** (3.35)	-0.2	2.4	-5.3*** (3.30)	-4.2*** (2.13)	-		
7	122.0	10.7*** (4.32)	4.5*** (1.81)	7.1*** (2.99)	-0.6	0.5	4.7*** (1.89)	-	
8	131.5	1.2	-5.0*** (3.27)	-2.4* (1.78)	-10.1*** (7.84)	-9.0*** (5.22)	-4.8*** (3.13)	-9.5*** (4.13)	-

* $P < 0.05$, ** $P < 0.01$, *** $P < 0.001$

Table 7.21. Games-Howell's *post hoc* test results for average mean coupling angle for the BA vs. NBA coupling (75-99%) by participant.

Participant	Mean	Mean Differences ($M_i - M_j$) (Cohen's d statistics are presented in parentheses)							
		1	2	3	4	5	6	7	8
1	99.4	-							
2	99.9	-0.5	-						
3	102.5	-3.1	-2.6	-					
4	102.6	-3.2** (1.98)	-2.7	-0.1	-				
5	96.5	2.9	3.4	6.0* (1.62)	6.1** (2.10)	-			
6	100.1	-0.7	-0.2	2.4	2.5	-3.6	-		
7	96.4	3.0* (1.48)	3.5* (1.53)	6.1** (2.03)	6.2*** (3.21)	0.1	3.7	-	
8	106.3	-6.9*** (4.05)	-6.4*** (3.19)	-3.8	-3.7*** (2.33)	-9.8*** (3.32)	-6.2** (2.06)	-9.9*** (4.93)	-

* $P < 0.05$, ** $P < 0.01$, *** $P < 0.001$

Table 7.22. Pearson product-moment correlation coefficients for: (i) mean coupling angle for the BA vs. NBA coupling and ball release speed for each participant; (ii) the average mean coupling angle for the BA vs. NBA coupling calculated across the 12 deliveries for each participant and average ball release speed; and (iii) mean coupling angle for the BA vs. NBA coupling for the best performing trial and corresponding ball release speed for each participant.

Participant	Pearson Product-Moment Correlation Coefficient (P -values in parentheses)		
	0-24%	25-49%	50-74%
1	-0.317 (0.315)	0.483 (0.112)	-0.307 (0.332)
2	0.205 (0.524)	-0.319 (0.312)	0.147 (0.648)
3	-0.201 (0.532)	-0.191 (0.553)	0.360 (0.250)
4	-0.162 (0.403)	0.597 (0.586)	0.204 (0.283)
5	-0.164 (0.611)	-0.153 (0.634)	0.159 (0.620)
6	0.604 (0.038)	0.055 (0.866)	-0.341 (0.277)
7	-0.395 (0.204)	0.536 (0.073)	0.676 (0.016)
8	-0.238 (0.457)	-0.126 (0.697)	-0.063 (0.849)
Average Trial	0.183 (0.663)	0.265 (0.525)	0.321 (0.438)
Best Trial	0.278 (0.505)	0.334 (0.419)	0.492 (0.216)
			0.644 (0.024)
			0.168 (0.602)
			0.204 (0.523)
			0.275 (0.952)
			0.315 (0.319)
			0.270 (0.396)
			-0.532 (0.075)
			-0.056 (0.864)
			-0.423 (0.296)
			-0.601 (0.116)

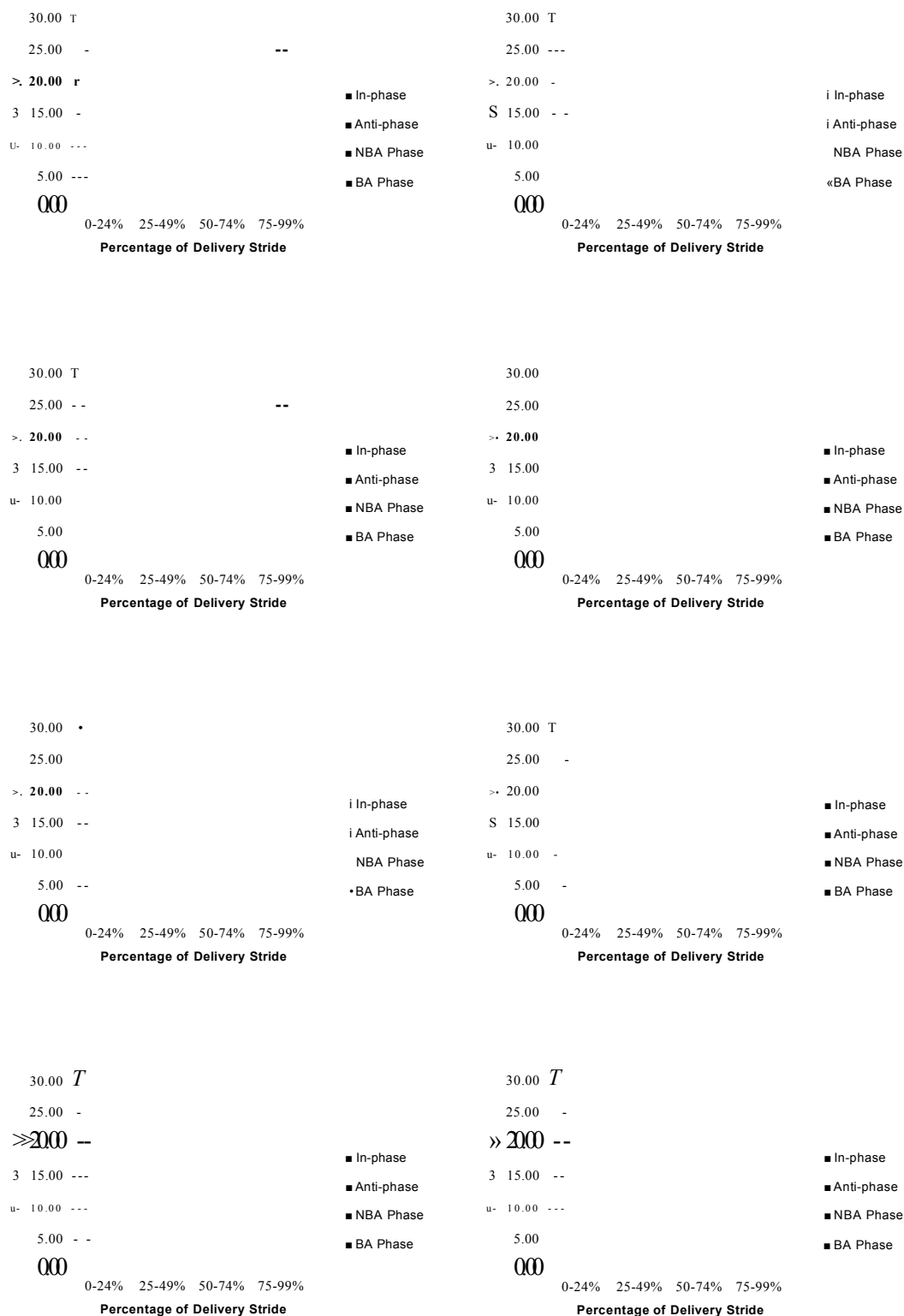

Figure 7.4. Histograms (mean \pm SD) of the types of coordination exhibited over the 12 performance trials for the BA vs. NBA coupling during the four phases (0-24%, 25-49%, 50-74% and 75-99%) of the delivery stride for participant 1 (top left) to 8 (bottom right).

Average mean (SD) coupling angle calculated during the 4 phases (0-24%, 25-49%, 50-74% and 75-99%) of the delivery stride over 12 performance trials for the BA vs. FL coupling in Table 7.23.

Table 7.23. Average mean (SD) coupling angle calculated during the 4 phases (0-24%, 25-49%, 50-74% and 75-99%) of the delivery stride over 12 performance trials for the BA vs. FL coupling.

Average Mean Coupling Angle for BA vs. FL Coupling (SD in parentheses)				
Participant	0-24%	25-49%	50-74%	75-99%
1	114.2 (2.7)	105.4 (1.4)	97.8 (3.3)	93.6 (1.4)
2	94.1 (2.6)	95.1 (1.3)	92.8 (2.1)*	92.2 (0.9)
3	80.4 (2.6)	93.8 (2.5)	90.2 (2.8)	104.9 (1.9)
4	101.3 (2.5)	92.5 (1.0)	92.6 (1.9)	94.9 (2.0)
5	97.9 (2.4)*	96.3 (1.1)	85.8 (1.7)	90.9 (1.7)
6	115.1 (2.2)*	107.6 (1.6)*	101.7(1.4)	101.0 (0.6)
7	96.7 (4.7)	104.8 (1.5)	101.4 (1.8)*	95.0 (1.1)*
8	107.1 (3.0)	101.9 (1.6)	95.2 (1.5)	94.1 (1.0)
Levene's F	<i>P</i> = 0.541	<i>P</i> = 0.071	<i>P</i> = 0.002**	<i>P</i> = 0.007**
Variance Ratio (H v L)	4.7:1	5.8:1	5.8:1	11.2:1

* Not normally distributed, ** Homogeneity of variance assumption violated

Anderson-Darling normality tests showed that 26 out of the 32 mean coupling angle data sets obtained from the 8 participants for the BA vs. FL coupling were normally distributed. However, Levene's tests revealed that the homogeneity of variance assumption was not met when testing for differences between participants for the following phases of the delivery stride: 50-74% ($P = 0.002$) and 75-99% ($P = 0.007$). The Welch's F test was, therefore, applied to determine statistically significant differences among participants for each of these phases and an adjusted ω^2 statistic was calculated to determine how much of the total variance could be attributed to differences between participants.

The Welch's F tests of average mean coupling angle showed statistically significant differences between the 8 participants for each of the 4 phases of the delivery stride for the BA vs. FL coupling: 0-24% – $F_{7, 88} = 183.15$, $P < 0.001$, adj. $\omega^2 = 0.930$; 25-49% – $F_{7, 88} = 174.33$, $P < 0.001$, $\omega^2 = 0.927$; 50-74% – Welch's $F_{7, 37.54} = 109.87$, $P < 0.001$, $\omega^2 = 0.888$; 75-99% – Welch's $F_{7, 37.17} = 186.82$, $P < 0.001$, adj. $\omega^2 = 0.931$.

Pairwise *post hoc* comparisons, using Games-Howell's and Tukey's tests for heterogeneous and homogeneous data sets, respectively, were implemented to identify differences in average mean coupling angles between participants. The results of these tests are summarised in Tables 7.24 to 7.27 along with Cohen's d standardised difference statistics for statistically significant mean differences. Of the 28 unique pairwise comparisons for the 0-24%, 25-49%, 50-74% and 75-99% phases of the

delivery stride for the BA vs. FL coupling, the average mean coupling angle was shown to be significantly different ($P < 0.05$) for 24, 24, 21 and 20 pairwise comparisons, respectively. The mean Cohen's d standardised difference statistic for the 0-24%, 25-49%, 50-74% and 75-99% phases were 5.52 (range 1.23-14.56), 5.53 (range 1.31-11.41), 4.23 (range 1.55-10.22) and 5.28 (range 1.71-11.45), respectively. All of the Cohen's d standardised difference statistics calculated for statistically significant mean differences were greater than the 1.2 threshold figure suggested by Hopkins *et al.* (2008) to represent a large effect.

To establish whether there were any associations between segmental coupling relationships and ball release speed within and between participants, Pearson product-moment correlation coefficients for: (i) mean coupling angle for the BA vs. FL coupling and ball release speed for each participant; (ii) the average mean coupling angle for the BA vs. FL coupling calculated across the 12 deliveries for each participant and average ball release speed; and (iii) mean coupling angle for the BA vs. FL coupling for the best performing trial and corresponding ball release speed for each participant were calculated. The results of these statistical tests can be found in Table 7.28. No statistically significant correlation coefficients (adj. $P > 0.003$) for segmental coupling relationships and ball release speed could be identified.

Histograms of the types of coordination exhibited over the 12 performance trials for the BA vs. FL coupling during the four phases (0-24%, 25-49%, 50-74% and 75-99%) of the delivery stride for each participant are shown in Figure 7.5.

Table 7.24. Tukey's *post hoc* test results for average mean coupling angle for the BA vs. FL coupling (0-24%) by participant.

Participant	Mean Differences ($M_i - M_j$) (Cohen's d statistics are presented in parentheses)							
	1	2	3	4	5	6	7	8
1	114.2	-	-	-	-	-	-	-
2	20.1*** (7.58)	-	-	-	-	-	-	-
3	33.9*** (12.80)	13.8*** (5.29)	-	-	-	-	-	-
4	101.3	-7.1*** (2.83)	-20.9*** (8.24)	-	-	-	-	-
5	97.9	-3.7* (1.53)	-17.5*** (4.62)	3.4	-	-	-	-
6	115.1	-0.8	-34.7*** (14.56)	-13.8*** (5.91)	-17.2*** (5.91)	-	-	-
7	96.7	17.5*** (4.57)	-16.3*** (4.31)	4.6*** (1.23)	1.2	18.4*** (5.04)	-	-
8	107.1	7.2*** (2.48)	-26.7*** (9.51)	-5.8*** (2.10)	-9.2*** (3.40)	8.0*** (3.04)	-10.4*** (2.64)	-

* $P < 0.05$, ** $P < 0.01$, *** $P < 0.001$

Table 7.25. Tukey's *post hoc* test results for average mean coupling angle for the BA vs. FL coupling (25-49%) by participant.

Participant	Mean Differences ($M_i - M_j$) (Cohen's d statistics are presented in parentheses)							
	1	2	3	4	5	6	7	8
1	105.4	-	-	-	-	-	-	-
2	95.1	10.2*** (7.66)	-	-	-	-	-	-
3	93.8	11.5*** (5.86)	1.3	-	-	-	-	-
4	92.5	12.9*** (10.78)	2.7** (2.18)	1.4	-	-	-	-
5	96.3	9.1*** (7.31)	-2.4** (1.31)	-3.8*** (3.53)	-	-	-	-
6	107.6	-2.2* (1.50)	-13.7*** (6.71)	-15.1*** (11.41)	-11.3*** (8.26)	-	-	-
7	104.8	0.6	-10.9*** (5.46)	-12.3*** (9.81)	-8.5** (6.54)	2.8** (1.85)	-	-
8	101.9	3.5*** (2.33)	-8.1*** (3.89)	-9.5*** (6.88)	-5.7*** (3.98)	5.7*** (3.55)	2.9*** (1.87)	-

* $P < 0.05$, ** $P < 0.01$, *** $P < 0.001$

Table 7.26. Games-Howell's *post hoc* test results for average mean coupling angle for the BA vs. FL coupling (50-74%) by participant.

Participant	Mean Differences ($M_i - M_j$) (Cohen's d statistics are presented in parentheses)							
	1	2	3	4	5	6	7	8
1	97.8	-	-	-	-	-	-	-
2	92.8	5.0** (1.82)	-	-	-	-	-	-
3	90.2	7.6*** (2.51)	2.6	-	-	-	-	-
4	92.6	5.1** (1.95)	0.2	-2.4	-	-	-	-
5	85.8	12.0*** (4.58)	4.4** (1.92)	6.8*** (3.80)	-	-	-	-
6	101.7	-3.9** (1.55)	-11.5*** (5.30)	-9.1*** (5.60)	-15.9*** (10.22)	-	-	-
7	101.4	-3.6	-11.2*** (4.79)	-8.8*** (4.77)	-15.6*** (8.74)	0.3	-	-
8	95.2	2.6	-5.0** (2.27)	-2.6* (1.56)	-9.4*** (5.89)	6.5*** (4.62)	6.2*** (3.74)	-

* $P < 0.05$, ** $P < 0.01$, *** $P < 0.001$

Table 7.27. Games-Howell's *post hoc* test results for average mean coupling angle for the BA vs. FL coupling (75-99%) by participant.

Participant	Mean	Mean Differences ($M_i - M_j$) (Cohen's <i>d</i> statistics are presented in parentheses)							
		1	2	3	4	5	6	7	8
1	93.6								
2	92.2	1.4							
3	104.9	-11.3*** (6.82)	-12.8*** (8.62)						
4	94.9	-1.3	-2.7* (1.71)	10.1*** (5.10)					
5	90.9	2.7** (1.75)	1.3	14.0*** (7.85)	4.0** (2.14)				
6	101.0	-7.4*** (6.85)	-8.9*** (11.45)	3.9*** (2.79)	-6.1*** (4.05)	-10.1*** (7.99)			
7	95.0	-1.3	-2.8*** (2.80)	10.0*** (6.44)	-0.1	-4.1*** (2.90)	6.1*** (6.79)		
8	94.1	-0.5	-1.9** (1.98)	10.9*** (7.14)	0.8	-3.2** (2.30)	6.9*** (8.21)	0.9	

* $P < 0.05$, ** $P < 0.01$, *** $P < 0.001$

Table 7.28. Pearson product-moment correlation coefficients for: (i) mean coupling angle for the BA vs. FL coupling and ball release speed for each participant; (ii) the average mean coupling angle for the BA vs. FL coupling calculated across the 12 deliveries for each participant and average ball release speed; and (iii) mean coupling angle for the BA vs. FL coupling for the best performing trial and corresponding ball release speed for each participant.

Participant	Pearson Product-Moment Correlation Coefficient (<i>P</i> -values in parentheses)			
	0-24%	25-49%	50-74%	75-99%
1	-0.133 (0.680)	0.214 (0.505)	0.213 (0.507)	0.272 (0.393)
2	-0.169 (0.599)	-0.163 (0.611)	-0.276 (0.385)	0.201 (0.529)
3	-0.299 (0.346)	0.194 (0.546)	0.412 (0.183)	0.335 (0.286)
4	0.087 (0.786)	0.295 (0.353)	0.330 (0.295)	0.091 (0.779)
5	-0.318 (0.314)	0.048 (0.884)	0.006 (0.983)	-0.475 (0.118)
6	-0.289 (0.363)	-0.446 (0.146)	-0.467 (0.126)	0.646 (0.023)
7	-0.117 (0.718)	0.039 (0.906)	0.572 (0.052)	0.275 (0.387)
8	-0.204 (0.525)	-0.497 (0.101)	0.118 (0.716)	0.666 (0.018)
Average Trial	0.139 (0.742)	0.489 (0.219)	0.376 (0.358)	0.234 (0.578)
Best Trial	0.108 (0.799)	0.554 (0.154)	0.580 (0.132)	0.151 (0.721)

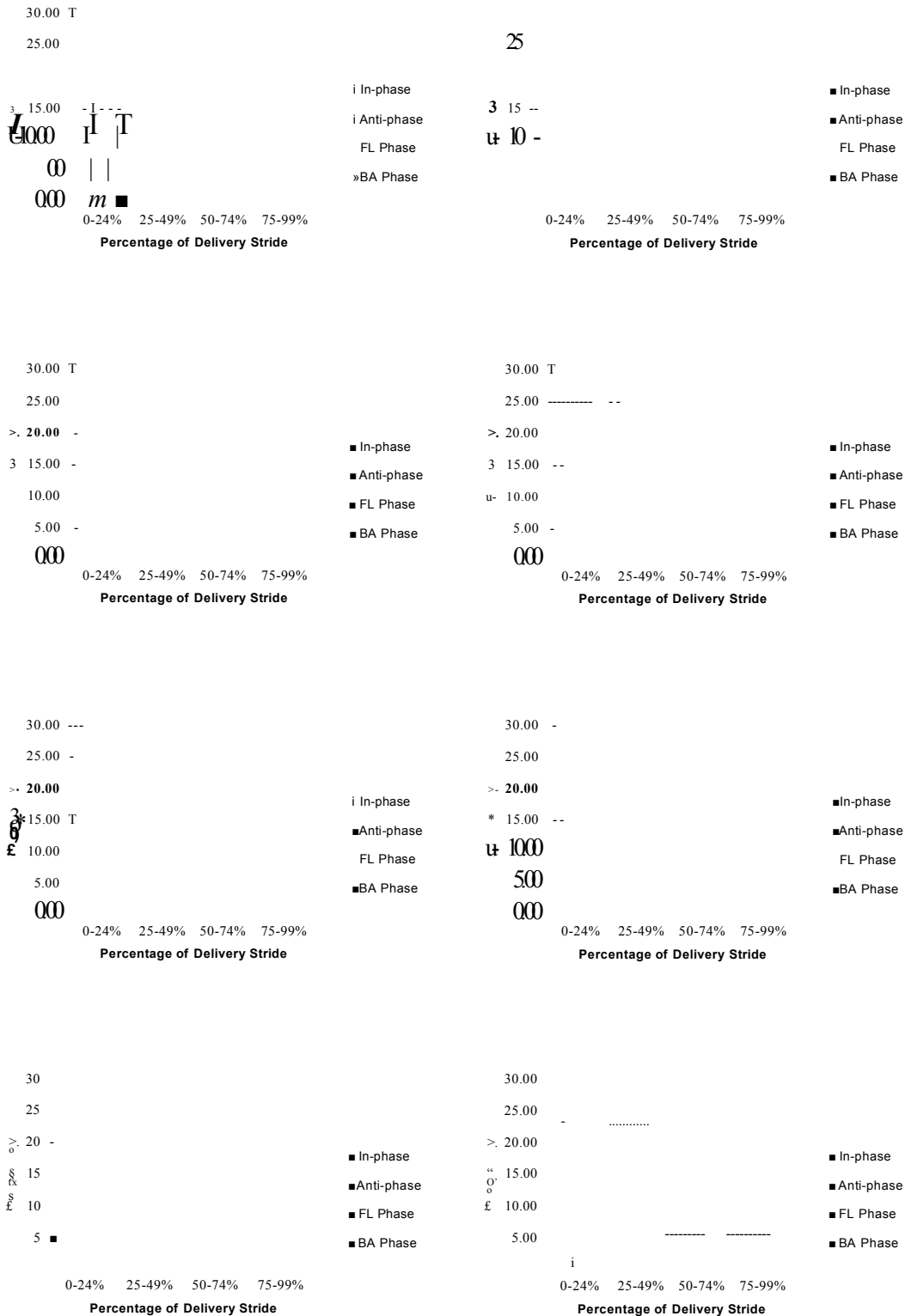

Figure 7.5. Histograms (mean \pm SD) of the types of coordination exhibited over the 12 performance trials for the BA vs. FL coupling during the four phases (0-24%, 25-49%, 50-74% and 75-99%) of the delivery stride for participant 1 (top left) to 8 (bottom right).

Average mean (SD) coupling angle calculated during the 4 phases (0-24%, 25-49%, 50-74% and 75-99%) of the delivery stride over 12 performance trials for the UT vs. P coupling for Table 7.29.

Table 7.29. Average mean (SD) coupling angle calculated during the 4 phases (0-24%, 25-49%, 50-74% and 75-99%) of the delivery stride over 12 performance trials for the UT vs. P coupling.

Average Mean Coupling Angle for UT vs. P Coupling (SD in parentheses)				
Participant	0-24%	25-49%	50-74%	75-99%
1	277.3 (5.2)	343.0 (7.2)	31.3 (4.1)	74.4 (3.0)
2	279.4 (9.3)	353.0 (7.7)	49.6 (3.0)	80.2 (3.6)
3	245.7 (7.0)	347.1 (23.7)	39.2 (3.4)*	70.6 (1.7)
4	270.6 (8.1)	279.6 (12.8)	26.1 (2.5)	72.1 (2.8)
5	279.7 (4.2)	336.5 (8.1)	37.6 (4.3)	78.0 (2.4)
6	265.0 (10.0)*	308.8 (10.1)	28.2 (3.8)	70.6 (1.9)
7	270.7 (4.2)	296.5 (8.0)	18.8 (4.5)	65.8 (3.5)
8	269.1 (4.6)	302.6 (7.1)	28.2 (3.6)	71.2 (2.9)
Levene's F	<i>P</i> = 0.074	<i>P</i> = 0.001**	<i>P</i> = 0.964	<i>P</i> = 0.034**
Variance Ratio (H v L)	5.8:1	11.1:1	3.2:1	4.2:1

* Not normally distributed, ** Homogeneity of variance assumption violated

Anderson-Darling normality tests showed that 30 out of the 32 mean coupling angle data sets obtained from the 8 participants for the UT vs. P coupling were normally distributed. However, Levene's tests revealed that the homogeneity of variance assumption was not met when testing for differences between participants for the following phases of the delivery stride: 25-49% ($P = 0.001$) and 75-99% ($P = 0.034$). The Welch's F test was, therefore, applied to determine statistically significant differences among participants for each of these phases and an adjusted ω^2 statistic was calculated to determine how much of the total variance could be attributed to differences between participants.

The Welch's F tests of average mean coupling angle showed statistically significant differences between the 8 participants for each of the 4 phases of the delivery stride for the UT vs. P coupling: 0-24% – $F_{7, 88} = 30.61$, $P < 0.001$, $\omega^2 = 0.683$; 25-49% – Welch's $F_{7, 37.55} = 91.45$, $P < 0.001$, adj. $\omega^2 = 0.868$; 50-74% – $F_{7, 88} = 79.29$, $P < 0.001$, $\omega^2 = 0.851$; 75-99% – Welch's $F_{7, 37.49} = 25.84$, $P < 0.001$, adj. $\omega^2 = 0.644$.

Pairwise *post hoc* comparisons, using Games-Howell's and Tukey's tests for heterogeneous and homogeneous data sets, respectively, were implemented to identify differences in average mean coupling angles between participants. The results of these tests are summarised in Tables 7.30 to 7.33 along with Cohen's d standardised difference statistics for statistically significant mean differences. Of the 28 unique pairwise comparisons for the 0-24%, 25-49%, 50-74% and 75-99% phases of the

delivery stride for the UT vs. P coupling, the average mean coupling angle was shown to be significantly different ($P < 0.05$) for 15, 20, 22 and 18 pairwise comparisons, respectively. The mean Cohen's d standardised difference statistic for the 0-24%, 25-49%, 50-74% and 75-99% phases were 2.82 (range 1.01-5.90), 4.32 (range 1.58-7.65), 3.79 (range 1.51-8.44) and 2.60 (range 1.52-4.09), respectively. Only 1 of the 75 Cohen's d standardised difference statistics calculated for statistically significant mean differences was less than the 1.2 threshold figure suggested by Hopkins *et al.* (2008) to represent a large effect.

To establish whether there were any associations between segmental coupling relationships and ball release speed within and between participants, Pearson product-moment correlation coefficients for: (i) mean coupling angle for the UT vs. P coupling and ball release speed for each participant; (ii) the average mean coupling angle for the UT vs. P coupling calculated across the 12 deliveries for each participant and average ball release speed; and (iii) mean coupling angle for the UT vs. P coupling for the best performing trial and corresponding ball release speed for each participant were calculated. The results of these statistical tests can be found in Table 7.34. No statistically significant correlation coefficients (adj. $P > 0.003$) for segmental coupling relationships and ball release speed could be identified.

Histograms of the types of coordination exhibited over the 12 performance trials for the UT vs. P coupling during the four phases (0-24%, 25-49%, 50-74% and 75-99%) of the delivery stride for each participant are shown in Figure 7.6.

Table 7.30 Tukey's *post hoc* test results for average mean coupling angle for the UT vs. P coupling (0-24%) by participant.

Participant	Mean Differences ($M_i - M_j$) (Cohen's <i>d</i> statistics are presented in parentheses)							
	1	2	3	4	5	6	7	8
1	277.3							
2	279.4	-2.2						
3	245.7	31.6*** (5.14)						
4	270.6	6.7	-24.9*** (3.30)					
5	279.7	-2.5	-34.0*** (5.90)	-9.1* (1.41)				
6	265.0	12.2** (1.55)	-19.4*** (2.24)	5.6	14.7*** (1.92)			
7	270.7	6.6	-25.0*** (4.36)	-0.1	9.0* (2.15)	-5.7		
8	269.1	8.2	-23.4*** (3.97)	1.5	10.6** (2.40)	-4.0	1.6	

* $P < 0.05$, ** $P < 0.01$, *** $P < 0.001$

Table 7.31. Games-Howell's *post hoc* test results for average mean coupling angle for the UT vs. P coupling (25-49%) by participant.

Participant	Mean Differences ($M_i - M_j$) (Cohen's <i>d</i> statistics are presented in parentheses)							
	1	2	3	4	5	6	7	8
1	343.0							
2	353.0	-10.0						
3	347.1	-4.1						
4	279.6	63.4*** (7.65)	67.5*** (3.55)					
5	336.5	6.5	16.5** (2.08)	10.6				
6	308.8	34.2*** (3.90)	44.2*** (4.91)	38.3** (2.11)	27.7*** (3.02)			
7	296.5	46.4*** (6.10)	56.4*** (7.16)	50.6*** (2.86)	40.0*** (4.95)	12.3		
8	302.6	40.3*** (5.65)	44.5** (2.55)	23.0*** (2.23)	33.9*** (4.44)	6.2	-6.1	

* $P < 0.05$, ** $P < 0.01$, *** $P < 0.001$

Table 7.32. Tukey's *post hoc* test results for average mean coupling angle for the UT vs. P coupling (50-74%) by participant.

Participant	Mean Differences ($M_i - M_j$) (Cohen's <i>d</i> statistics are presented in parentheses)							
	1	2	3	4	5	6	7	8
1	31.3							
2	49.6	-18.3*** (5.08)						
3	39.2	-7.9*** (2.09)						
4	26.1	5.2* (1.53)	10.4*** (3.21)					
5	37.6	-6.3** (1.51)	23.5*** (3.44)	13.2*** (4.36)				
6	28.2	3.1	12.0*** (3.24)	1.6	-11.5*** (3.29)			
7	18.8	12.5*** (2.92)	21.4*** (6.26)	3.1	-2.1	9.4*** (2.34)		
8	28.2	3.1	30.8*** (8.06)	21.4*** (6.41)	7.3*** (2.02)	18.8*** (4.31)	9.4*** (2.28)	
					-2.2	0.0	-9.5*** (2.31)	

* $P < 0.05$, ** $P < 0.01$, *** $P < 0.001$

Table 7.33. Games-Howell's *post hoc* test results for average mean coupling angle for the UT vs. P coupling (75-99%) by participant.

Participant	Mean Differences ($M_i - M_j$)							
	(Cohen's <i>d</i> statistics are presented in parentheses)							
	1	2	3	4	5	6	7	8
1	74.4							
2	-5.8** (1.76)	80.2						
3	3.8* (1.55)	9.7*** (3.43)						
4	2.2	8.1*** (2.53)	-					
5	-3.6	2.2	-1.6					
6	3.8* (1.52)	9.6*** (3.43)	-7.4*** (3.56)	-5.9*** (2.28)				
7	8.6*** (2.65)	14.4*** (4.09)	0.0	1.6	7.4*** (3.45)			
8	3.2	9.1*** (2.78)	-0.6	1.0	12.2*** (4.09)	4.8** (1.72)		
					6.8*** (2.58)	-0.6	-5.4** (1.69)	

* $P < 0.05$, ** $P < 0.01$, *** $P < 0.001$

Table 7.34. Pearson product-moment correlation coefficients for: (i) mean coupling angle for the UT vs. P coupling and ball release speed for each participant; (ii) the average mean coupling angle for the UT vs. P coupling calculated across the 12 deliveries for each participant and average ball release speed; and (iii) mean coupling angle for the UT vs. P coupling for the best performing trial and corresponding ball release speed for each participant.

Participant	Pearson Product-Moment Correlation Coefficient							
	(P-values in parentheses)							
	0-24%	25-49%	50-74%	75-99%				
1	-0.117 (0.716)	-0.084 (0.794)	0.082 (0.799)	-0.365 (0.243)				
2	-0.298 (0.347)	-0.031 (0.924)	0.177 (0.582)	-0.088 (0.785)				
3	-0.517 (0.052)	-0.333 (0.289)	0.326 (0.301)	0.210 (0.514)				
4	0.589 (0.044)	0.352 (0.262)	-0.127 (0.965)	0.369 (0.238)				
5	-0.601 (0.039)	0.031 (0.924)	-0.126 (0.696)	-0.360 (0.250)				
6	0.482 (0.113)	0.310 (0.326)	0.196 (0.524)	0.137 (0.672)				
7	-0.070 (0.830)	0.116 (0.720)	-0.673 (0.016)	-0.278 (0.382)				
8	0.108 (0.739)	0.375 (0.229)	0.515 (0.087)	0.241 (0.452)				
Average Trial	-0.135 (0.750)	0.264 (0.528)	-0.257 (0.538)	-0.301 (0.469)				
Best Trial	-0.178 (0.673)	-0.241 (0.565)	-0.153 (0.717)	-0.604 (0.113)				

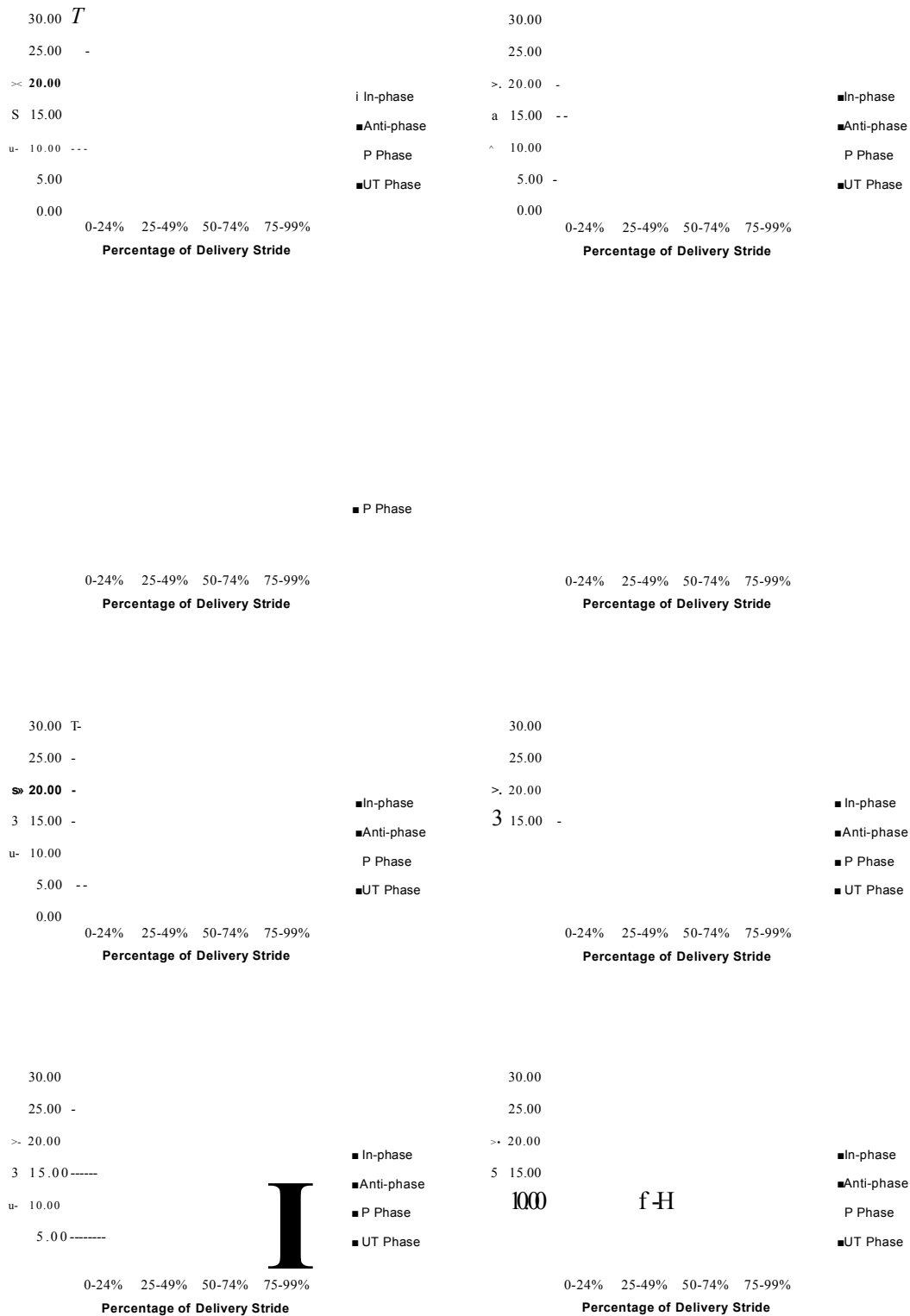

Figure 7.6. Histograms (mean \pm SD) of the types of coordination exhibited over the 12 performance trials for the UT vs. P coupling during the four phases (0-24%, 25-49%, 50-74% and 75-99%) of the delivery stride for participant 1 (top left) to 8 (bottom right).

7.3 Discussion

The aims of this study were to: (i) demonstrate the utility and application of various ‘complex’ analytical techniques to cricket fast bowling by using them to quantify intersegmental coupling relationships between various upper and lower extremity body segments; (ii) identify whether any systematic differences in these coupling relationships existed between individual fast bowlers; and (iii), establish whether there was any association between these coupling relationships and ball release speed both within and between fast bowlers.

The ‘complex’ analytical techniques selected for use in this study were cross-correlation functions and vector coding. Cross-correlation functions were used because they had been applied, albeit infrequently, to analyses of throwing (e.g., McDonald, van Emmerik & Newell, 1989), hitting (e.g., Temprado *et al.*, 1997) and kicking (e.g., Chow, Davids, Button & Koh, 2008) skills that have been shown to exhibit similar proximal-to-distal sequencing of segmental motion. Vector coding was preferred to other ‘complex’ analytical techniques, such as continuous relative phase, because it is easier to interpret, it makes fewer assumptions (i.e., data do not need to be sinusoidal) and no normalisation is required, thus enabling the true spatial information in the data to be maintained (Wheat & Glazier, 2006). Furthermore, vector coding quantifies relative motion information that has been shown to be used in the subjective evaluation of sports techniques (e.g., Sparrow & Sherman, 2001). Both techniques provided some useful insights into the temporal and spatial characteristics of intersegmental coordination not previously reported in the scientific literature on cricket fast bowling, which are discussed in more detail in sections 7.3.1 and 7.3.2.

7.3.1 Cross-Correlation Analysis

The application of cross-correlation functions enabled the type of coupling relationship, the degree of linkage or strength of the coupling, and the phase relation between the segments comprising each of the 4 segmental couplings (NBA vs. FL, BA vs. NBA, BA vs. FL and UT vs. P) during the period between BFI and BR to be examined. As expected, the NBA vs. FL and UT vs. P couplings exhibited in-phase coupling relationships, whereas the BA vs. NBA and BA vs. FL couplings exhibited anti-phase coupling relationships (see Table 7.4). The segments comprising each of the 4 segment couplings for all participants also exhibited either a moderate (0.5+), strong (0.7+) or very strong (0.9+) coupling relationship. The BA vs. NBA segment coupling

consistently displayed the strongest coupling (0.9+) and the UT vs. P segment coupling the weakest (0.6+) across participants. The NBA vs. FL and BA vs. FL segment couplings exhibited very strong (0.9+) coupling relationships for all participants except for participants 3 and 5 who typically only exhibited moderate (~0.6) coupling relationships (see Table 7.4).

The majority of segments comprising each of the four couplings moved in synchrony except for the UT vs. P coupling (see Appendix H), where it was found that the rotation of the P was consistently initiated prior to the rotation of the UT. This sequencing of segmental motion has previously been shown to be characteristic of many unilateral hitting and throwing actions in sport, where the transfer of energy and momentum along the kinematic chain is typically initiated by a rapid rotation of the pelvis (e.g., Bartlett & Robins, 2008; Elliott *et al.*, 2008). Interestingly, participants 3 and 5 exhibited opposite phase relationships for the NBA vs. FL coupling. For participant 3, it was shown that the NBA moved prior to the FL, whereas the opposite occurred for participant 5. For all other participants, however, the segments comprising this segment coupling were shown to move in synchrony.

Despite the majority of participants exhibiting strong or very strong coupling relationships for the four segment couplings, there was evidence of differences between individual participants. The analysis of pairwise comparisons revealed that, for the four segment couplings, there was a statistically significant difference in the mean Z-transformed cross-correlation coefficient between each participant and at least three of the other participants (see Tables 7.6 to 7.9). Moreover, for the majority of participants there were statistically significant differences with most, if not all, of the other participants across the four segment couplings. For example, participants 3, 4 and 7 exhibited statistically significant differences with all other bowlers for the UT vs. P, NBA vs. FL and BA vs. NBA couplings, respectively (see Figure 7.7). In terms of the magnitudes of the statistically significant mean differences for the unique pairwise comparisons, 15.1% were shown to be large (i.e., >1.20), 39.2% were very large (i.e., >2.0), and 39.2% were extremely large (i.e., >4.0), according to the criteria laid out by Hopkins *et al.* (2008).

Having established that there were statistically significant, and meaningfully large, differences in coupling relationships for the four segment couplings between participants, it was necessary to examine whether there were any associations between coupling relationships and ball release speed within and between participants. However,

no statistically significant associations could be identified between either the coupling relationships for the best performing trial and ball release speed across participants, between the coupling relationships for an average trial and ball release speed across participants, and between the coupling relationships for individual trials and ball release speed within participants.

Participant

Figure 7.7. Histogram of statistically significant pairwise differences in cross-correlation coefficients per participant for the four segment couplings (NBA vs. FL, BA vs. NBA, BA vs. FL and UT vs. P).

7.3.2 *Vector Coding Analysis*

As cross-correlation functions only provided an indication of the temporal similarity between the segments comprising each segment coupling (Pohl & Buckley, 2008), vector coding was applied to examine the relative magnitudes and excursion ratios of the segments comprising the four segmental couplings (NBA vs. FL, BA vs. NBA, BA vs. FL and UT vs. P) during the four phases (0-24%, 25-49%, 50-74% and 75-99%) of the period between BFI and BR.

An analysis of the histograms summarising the different types of coordination exhibited over the 12 performance trials showed that there were clear similarities between participants across the 4 segment couplings. The NBA vs. FL coupling was exhibited in-phase and, more predominantly, NBA phase movement, particularly between 25-74% of the delivery stride. The BA vs. NBA coupling exhibited predominantly anti-phase movement between 0-74% and then BA phase movement during the 75-99% phase. The BA vs. FL coupling exhibited almost exclusively BA phase movement, particularly between 25-99%. Finally, the UT vs. P coupling exhibited predominantly UT phase movement during the 0-24% and 75-99% phases, and a combination of the 4 different types of coordination between 25-74%. This segment coupling exhibited less consistent patterning than the other three couplings, thus

reflecting the more complex motion and interaction of the UT and P segments. All segment couplings produced motions that were broadly consistent with the theory of proximal-to-distal sequencing.

Despite clear similarities in the type of coordination exhibited between individual participants during the delivery stride, a more fine-grained inspection of the mean coupling angle revealed very marked differences between participants. Of the 112 unique pairwise comparisons for the 4 phases of each of the NBA vs. FL, BA vs. NBA, BA vs. FL and UT vs. P couplings, 77, 66, 89 and 75 were shown to be statistically significant. Indeed, statistically significant differences were found between each participant and at least one other participant with the vast majority of participants exhibiting differences with at least four other participants across the four couplings (see Tables 7.8 to 7.11). In terms of the magnitudes of the statistically significant mean differences for the unique pairwise comparisons, it was found that 15.6% were shown to be large (i.e., >1.20), 40.3% were very large (i.e., >2.0), and 44.1% were extremely large (i.e., >4.0) for the NBA vs. FL coupling, 21.2% were shown to be large, 42.4% were very large and 36.4% were extremely large for the BA vs. NBA coupling, 15.7% were shown to be large, 24.7% were very large and 59.6% were extremely large for the BA vs. FL coupling, and 18.7% were shown to be large, 48.0% were very large and 32% were extremely large for the UT vs. P coupling, according to the criteria laid out by Hopkins *et al.* (2008).

These results appear to concur with those of the study reported in Chapter VI where it was found that distinct qualitative differences in the global topology among the 8 participants were reported. However, because the relative motion of all body segments were effectively considered simultaneously, the local differences in relative motion among pairs of body segments that contributed to differences in global topology could not be established. By analysing the motions of pairs of body segments using vector coding, it has been possible to identify where these differences might lie.

Having established that there were statistically significant, and meaningfully large, differences in the average mean coupling angle for the four segment couplings between participants, it was necessary to examine whether there were any associations between mean coupling angle and ball release speed within and between participants. Although there was one statistically significant association, no systematic trends could be identified. Accordingly, there does not appear to be a clear relationship between

Participant

Figure 7.8. Histogram of statistically significant pairwise differences in coupling per participant for the NBA vs. FL coupling.

Participant

Figure 7.9. Histogram of statistically significant pairwise differences in coupling per participant for the BA vs. NBA coupling.

Participant

Figure 7.10. Histogram of statistically significant pairwise differences in coupling per participant for the BA vs. FL coupling.

Participant

Figure 7.11. Histogram of statistically significant pairwise differences in coupling per participant for the UT vs. P coupling.

coordination patterns and ball release speed, which, from a coaching perspective, is problematic.

7.4 Conclusion

The results of this study provide a preliminary insight into the coupling relationships between key upper and lower extremity segments during fast bowling. The implementation of cross-correlation functions showed that moderate to very strong coupling relationships existed between the NBA vs. FL, BA vs. NBA, BA vs. FL and UT vs. P segment couplings and that the segments comprising the majority of these couplings moved in synchrony. The only segment coupling that was consistently asynchronous was the UT vs. P coupling where it was identified that the pelvis rotation was initiated before the rotation of the upper torso. Statistically significant mean differences in both cross-correlation coefficients and mean coupling angle for the NBA vs. FL, BA vs. NBA, BA vs. FL and UT vs. P segment couplings between individual participants were also reported, thus providing further evidence of individual-specific coordination patterns or movement signatures. However, no statistically significant associations between these coupling relationships and ball release speed could be established either within or between individual participants. This study further highlights the difficulties faced by sports biomechanists when attempting to identify associations between technique and outcomes in sports skills. Clearly, this is an important issue that sports biomechanists must address if they are to make a more substantive contribution to the enhancement of sports performance.

Chapter VIII

General Discussion and Recommendations for Future Research

8.0 Introduction

The aims of this thesis, as stated in Chapter I, were to: (i) enhance understanding of the biomechanical and motor control processes that underpin proficient fast bowling performance using dynamical systems theory and ‘complex’ analyses; and (ii), demonstrate the application of dynamical systems theory and the utility of ‘complex’ analyses to performance-oriented sports biomechanics research, more generally, using cricket fast bowling as a representative task vehicle. This chapter summarises the research work undertaken, considers the theoretical and applied contributions it has made, and provides some recommendations for future research.

8.1 Summary of Research

Based on the review of literature and the theoretical development of the biomechanics-motor control nexus provided in Chapters II and III, respectively, the empirical studies reported in this thesis focused on within- and between-bowler differences in coordination patterns at different levels of analysis and their relationship to performance (ball release speed). Prior to these empirical studies, however, a study examining the suitability of manual coordinate digitising for multiple single-participant research designs was conducted and reported in Chapter V. The main findings of this study were:

- Of the 33 time-discrete kinematic variables examined, 31 exhibited between-participant variances and re-digitisation variances that accounted for the largest and smallest portions of total variance, respectively.
- Re-digitisation variance accounted for less than 5% of total variance in 29 out of the 33 time-discrete variables with 15 of these exhibiting less than 1% of total variance.
- For the 45 time-continuous data sets analysed, it was found that measurement error, on average, accounted for 17.2% of movement variability in each data set with the proportion of measurement error ranging from 4.3 to 41.0%.

Considered together, these findings indicate that the operator-digitising system used was sufficiently sensitive to reliably measure differences in kinematics both within and between participants over repeated performance trials.

In Chapter VI, fast bowling techniques at a global, whole-body level were analysed using Kohonen SOMs. Previously, this particular artificial neural network had only featured sparingly in biomechanical investigations of sports techniques and had not

been applied to kinematic analyses of cricket fast bowling techniques. The main findings of this study were:

- Similarities in the shape and path of SOM trajectories existed for participants 1 and 4, participants 2 and 3, and participants 6 and 8.
- However, distinctive qualitative differences were evident between bowlers signifying participant-specific coordination patterns.
- These individualities were likely to be attributable to differences in organismic constraints and, to a lesser extent, the intrinsic dynamics (i.e., preferred states of coordination tendencies that are present at the beginning of the learning process) of each of the bowlers.
- Although not conclusive, these empirical and theoretical findings signify that a common optimal movement pattern for fast bowling is unlikely to exist.

This study also provided further evidence that SOMs are an effective tool for capturing topological differences in sports techniques at a whole-body global level of analysis. However, their utility and practical application might be compromised because:

- Optimal movement solutions for specific individuals and, therefore, the corresponding SOM trajectory cannot currently be determined.
- Identifying features of the SOM trajectory that correspond to specific aspects of technique does not currently appear to be possible.

These two limitations, combined with the conceptual and computational complexities of SOMs, were identified as significant barriers precluding the more widespread application of this artificial neural network in an applied sports context.

In Chapter VII, intersegmental coordination in fast bowling was analysed using cross-correlation functions and vector coding in combination with a multiple single-participant research design. Previously, these ‘complex’ analytical techniques had seldom been applied to human movement beyond studies of locomotion and this was the first time they had been used to investigate coordination among limb and torso segments in cricket fast bowling. The main findings of this study were:

- In-phase coupling relationships were found for the NBA vs. FL and UT vs. P segment couplings and anti-phase coupling relationships were found for the BA vs. NBA and UT vs. P segment couplings.

- Cross-correlation functions showed that moderate (0.5+) to very strong (0.9+) relationships existed for the four segment couplings (NBA vs. FL, BA vs. NBA, BA vs. FL, UT vs. P).
- The BA vs. NBA and UT vs. P segment couplings consistently displayed the strongest relationship (0.9+) and weakest (0.6+) relationships, respectively.
- All segment couplings moved in synchrony except for the UT vs. P coupling where it was found that the rotation of the P segment was consistently initiated prior to the UT segment.
- Statistically significant ($P < 0.05$) and meaningfully large (>1.20) to extremely large (>4.0) differences in mean Z-transformed cross-correlation coefficients existed between each individual bowler and at least three other bowlers for the four segment couplings.
- No associations between cross-correlation coefficients for the four segment couplings during the delivery stride (0-100%) and ball release speed could be identified either within or between bowlers.
- Vector coding showed that: the NBA vs. FL coupling relationship was in-phase and, more predominantly, NBA phase between 25-74% of the delivery stride; the BA vs. NBA coupling relationship was anti-phase between 0-74% and then BA phase during 75-99% of the delivery stride; the BA vs. FL coupling relationship was almost exclusively BA phase between 25-99% of the delivery stride; and the UT vs. P coupling relationship was UT phase during 0-24% and 75-99% of the delivery stride, and a combination of the four different types of coordination between 25-74% of the delivery stride.
- Statistically significant ($P < 0.05$) and meaningfully large (>1.20) to extremely large (>4.0) differences in average mean coupling angle over the four phases of the delivery stride (0-24%, 25-49%, 50-74%, 75-99%) existed between each individual bowler and at least one other bowler with the vast majority of bowlers exhibiting differences with at least four other bowlers across the four segment couplings.
- No systematic relationships could be identified between average mean coupling angle for the four segment couplings and ball release speeds either within or between bowlers.

These findings appear to provide further support for the results reported in Chapter VI and may provide an indication of where differences existed at a local level in that study.

They also provide further evidence of the difficulties in making associations between technique and outcomes.

8.2 Implications for Coaching Cricket Fast Bowling and Other Sports Techniques

An important aspect of coaching cricket fast bowling techniques, or any other sports techniques for that matter, is the identification and elimination of errors with the aim of ultimately improving performance. However, the methods by which coaches and athletes go about diagnosing and remediating technical faults have been criticised by some sports biomechanists for being inefficient and ineffective. For example, Bartlett (1999) claimed that: “Much sports technique training evolves essentially through a process of trial and error. Theories about the best technique develop in an ad hoc fashion, and the participants (coaches, athletes and, sometimes, sports scientists) experiment with aspects of the technique and adopt those changes that improve the performance. However, at the elite level of sport, this trial and error method of establishing an ideal technique is hazardous” (p. 179). He went on to argue that a more objective approach to detecting errors in technique was needed and that sports biomechanics, particularly theory-driven statistical modelling and optimisation modelling, could help to identify theoretically correct, or ideal, techniques in a range of sports.

The theoretical analysis provided in Chapter III of this thesis suggests that sports biomechanists are currently not well-equipped to identify faults in the techniques of individual athletes. Theory-driven statistical modelling based on hierarchical performance models provides little information about underlying movement patterns that define technique and optimisation modelling cannot currently identify optimal movement patterns for specific individuals in the vast majority of sports. The empirical analyses reported in Chapters VI and VII indicate that different movement patterns can be used to produce similar performance outcomes and that there does not appear to be any obvious relationship between technique and ball release speed in cricket fast bowling. These findings signify a potential dilemma for coaches and sports biomechanists: if fast bowlers can adopt different techniques but still perform proficiently, how do we assess technique and identify faults in order to improve it?

It appears that until optimal movement patterns for specific fast bowlers can be identified, the use of a best performing trial as a reference, as recommended in Chapter

VI, might be the best available option. Interestingly, though, several studies in the motor learning literature have indicated that, contrary to the views of Bartlett (1999), the heuristic approach might be a legitimate strategy for improving technique and performance. For example, Vereijken and Whiting (1990) demonstrated that discovery learning produced better performances in a ski simulator task than other types of learning methods, such as knowledge of results and the use of a criterion technique model. From a dynamical systems theoretical perspective, motor learning is considered to be a type of ‘search and refinement process’ whereby learners explore and probe the boundaries of the ‘perceptual-motor workspace’ to find and develop robust movement solutions (e.g., Newell, Kugler, van Emmerik & McDonald, 1989; Newell, McDonald & Kugler, 1991; Newell & McDonald, 1992). It has been suggested that augmented information, including biomechanical feedback, could be used to help channel the search away from dysfunctional movement patterns (i.e., those that lead to poor performances or may predispose to injury) and towards more functional, possibly optimal, movement solutions for specific individuals (e.g., Hodges & Franks, 2002). For sports biomechanists to be an integral part of the skill acquisition process, a research priority must be to identify what movement patterns are, and are not, functional for individual fast bowlers.

8.3 Concluding Remarks and Recommendations for Future Research

Although dynamical systems theory has been criticised over the years for being descriptive rather than explanatory (Rosenbaum, 1998), and that many of the arguments made have been “in principle” in nature (Weeks & Proctor, 1991) in that they have not been subjected to, or have not been readily amenable to, empirical analysis, the theoretical and empirical findings reported in this thesis indicate that it is a theoretical framework that is worth persevering with. As technology improves, specifically with advancements in 3D markerless motion tracking systems, researchers will become better equipped to more accurately measure sports techniques in their natural, dynamic performance environments, thus enabling the emergence of coordination patterns under a variety of different organismic, environmental and task constraints to be investigated. The ‘complex’ analytical tools of dynamical systems theory could have a useful role to play in quantifying the stability and variability of spatio-temporal characteristics of these coordination patterns, especially as coaches and athletes have been shown to rely on relative motion information when assessing sports techniques (e.g., Sparrow &

Sherman, 2001). However, researchers need to be mindful of their underlying assumptions and diligently check the results they produce to avoid arriving at incorrect conclusions.

In terms of recommendations for future research into the biomechanics and motor control of cricket fast bowling performance, an important line of enquiry—as it is in applied sports biomechanics and performance analysis research (e.g., Lees, 2002; McGarry, 2009; Glazier, 2010) more generally—is identifying associations between behaviour or technique and outcome. As demonstrated in this thesis, however, this task appears to be a particularly challenging undertaking but one sports biomechanists must meet if they are to satisfy one of their main aims of enhancing sports performance (Bartlett, 1999). As the information provided here and elsewhere suggests, it is unlikely that a single coupling relationship, when taken in isolation, is capable of predicting fast bowling performance to any satisfactory degree. Indeed, it appears that a complex interaction of limb movements with compensatory mechanisms is likely to be responsible for determining performance outcome. Future research needs to focus on the individual-specific segmental interactions and compensatory mechanisms underpinning fast and accurate bowling if it is to be useful in an applied context. The multiple single-participant research design combined with the analytical tools and concepts of dynamical systems theory advocated in this thesis appears to be appropriate for this investigative endeavour even though the empirical data reported only partially supports this viewpoint. Other methodological techniques, such as inverse dynamics and energetic analyses, may also prove useful in future research, especially if power and energy flows can be associated to coordination patterns to establish which coordination patterns lead to increased transfer of energy and power.

Chapter IX

References

- Abdel-Aziz, Y.I. & Karara, H.M. (1971). Direct linear transformation from comparator coordinates into object space coordinates in close-range photogrammetry. In *American Society of Photogrammetry Symposium on Close Range Photogrammetry*, pp. 1-18. Fall Church, VA: American Society of Photogrammetry.
- Abernethy, B. (1981). Mechanisms of skill in cricket batting. *Australian Journal of Sports Medicine*, **13**, 3-10.
- Adrian, M.J. & Cooper, J.M. (1995). *Biomechanics of Human Movement (2nd Edition)*. Madison, WI: Brown & Benchmark.
- Amblard, B., Assaiante, C., Lekhel, H. & Marchand, A.R. (1994). A statistical approach to sensorimotor strategies: Conjugate cross-correlations. *Journal of Motor Behavior*, **26**, 103-112.
- Arutyunyan, G.H., Gurfinkel, V.S. & Mirskii, M.L. (1968). Investigation of aiming at a target. *Biophysics*, **13**, 536-538.
- Atwater, A.E. (1979). Biomechanics of overarm throwing movements and of throwing injuries. *Exercise and Sport Sciences Reviews*, **7**, 43-85.
- Bartlett, R.M. (1997). Current issues in the mechanics of athletic activities: A position paper. *Journal of Biomechanics*, **30**, 477-486.
- Bartlett, R.M. (1999). *Sports Biomechanics: Reducing Injury and Improving Performance*. London: E & FN Spon.
- Bartlett, R.M. (2006). Artificial intelligence in technique analysis – past, present and future. *International Journal of Performance Analysis in Sport*, **4**, 4-19.
- Bartlett, R.M. (2007). *Introduction to Sports Biomechanics: Analysing Human Movement Patterns (2nd Edition)*. London: Routledge.
- Bartlett, R. (2008). Movement variability and its implications for sports scientists and practitioners: An overview. *International Journal of Sports Science & Coaching*, **3**, 113-124.
- Bartlett, R. & Robins, M. (2008). Biomechanics of throwing. In *Routledge Handbook of Biomechanics and Human Movement Science* (edited by Y. Hong & R. Bartlett), pp. 285-296. London: Routledge.
- Bartlett, R., Bussey, M. & Flyger, N. (2006). Movement variability cannot be determined reliably from no-marker conditions. *Journal of Biomechanics*, **39**, 3076-3079.
- Bartlett, R., Wheat, J. & Robins, M. (2007). Is movement variability important for sports biomechanists? *Sports Biomechanics*, **6**, 224-243.
- Bartlett, R.M., Stockill, N.P., Elliott, B.C. & Burnett, A.F. (1996). The biomechanics of fast bowling in men's cricket: A review. *Journal of Sports Sciences*, **14**, 403-424.
- Barton, G., Lees, A., Lisboa, P. & Attfield, S. (2006). Visualisation of gait data with Kohonen self-organising neural maps. *Gait & Posture*, **24**, 46-53.
- Barton, G., Lisboa, P., Lees, A., Attfield, S. (2007). Gait quality assessment using self-organising artificial neural networks. *Gait & Posture*, **25**, 374-379.
- Barton, G.J., Hawken, M.B., Scott, M.A. & Schwartz, M.H. (2010). Movement Deviation Profile: A measure of distance from normality using a self-organizing neural network. *Human Movement Science*.

- Batschelet, E. (1981). *Circular Statistics in Biology*. London: Academic Press.
- Bates, B.T. (1996). Single-subject methodology: An alternative approach. *Medicine & Science in Sports & Exercise*, **28**, 631-638.
- Bates, B.T., Dufek, J.S. & Davis, H.P. (1992). The effect of trial size on statistical power. *Medicine & Science in Sports & Exercise*, **24**, 1059-1068.
- Bates, B.T., James, C.R. & Dufek, J.S. (2004). Single-subject analysis. In *Innovative Analyses of Human Movement: Analytical Tools for Human Movement Research* (edited by N. Stergiou), pp. 3-28. Champaign, IL: Human Kinetics.
- Bauer, H.U. & Schöllhorn, W. (1997). Self-organizing maps for the analysis of complex movement patterns. *Neural Processing Letters*, **5**, 193-199.
- Baumann, W. (1987). Biomechanics of sports – current problems. In *Biomechanics: Basic and Applied Research* (edited by G. Bergmann, R. Kolbel and A. Rohlmann), pp. 51-58. Lancaster, UK: Academic Publishers.
- Baumann, W. (1992). Perspectives in methodology in biomechanics of sport. *Proceedings of the Xth Symposium of the International Society of Biomechanics in Sports* (edited by R. Rodano, G. Ferrigno and G.C. Santambrogio), pp.97-104. Milan: Edi Ermes.
- Beek, P.J., Dessing, J.C., Peper, C.E. & Bullock, D. (2003). Modelling the control of interceptive actions. *Philosophical Transactions of the Royal Society*, **B358**, 1511-1523.
- Bernstein, N.A. (1967). *The Coordination and Regulation of Movements*. Oxford: Pergamon Press.
- Bingham, G.P. (1988). Task specific devices and the perceptual bottleneck. *Human Movement Science*, **7**, 225-264.
- Boneau, C.A. (1960). The effects of violations of assumptions underlying the *t* test. *Psychological Science*, **57**, 49-64.
- Bradshaw, E.J., Keogh, J.W.L., Hume, P.A., Maulder, P.S., Nortje, J. & Marnewick, M. (2009). The effect of biological movement variability on the performance of the golf swing in high- and low-handicapped players. *Research Quarterly for Exercise and Sport*, **80**, 185-196.
- Brewin, M.A. & Kerwin, D.G. (2003). Accuracy of scaling and DLT reconstruction technique for planar motion analyses. *Journal of Applied Biomechanics*, **19**, 79-88.
- Brisson, T.A. & Alain. C. (1996). Should common optimal movement patterns be identified as the criterion to be achieved? *Journal of Motor Behavior*, **28**, 211-223.
- Burden, A.M. & Bartlett, R.M. (1990a). A kinematic investigation of elite fast and fast medium cricket bowlers. In *Proceedings of the VIIIth International Symposium of the Society of Biomechanics in Sport* (edited by M. Nosek, D. Sojka, W.E. Morrison & P. Susanka), pp.41-46. Prague: Conex.
- Burden, A.M. & Bartlett, R.M. (1990b). A kinematic comparison between elite fast bowlers and college fast medium bowlers. In *Proceedings of the Sports Biomechanics Section of the British Association of Sports Sciences*, No. 15. Leeds: BASS.

- Burden, A.M. & Bartlett, R.M. (1991). An electromyographical analysis of fast-medium bowling in cricket. In *Electromyographical Kinesiology: Proceedings of the VIIIth Congress of the International Society of Electrophysiological Kinesiology* (edited by P.A. Anderson, D.J. Hobart & J.V. Danoff), pp. 457-460. Amsterdam: Elsevier.
- Burnett, A.F., Elliott, B.C. & Marshall, R.N. (1995). The effect of a 12-over spell on fast bowling technique in cricket. *Journal of Sports Science*, **13**, 329-341.
- Burnett, A.F., Barrett, C.J., Marshall, R.N., Elliott, B.C. & Day, R.E. (1998). Three-dimensional measurement of lumbar spine kinematics for fast bowlers in cricket. *Clinical Biomechanics*, **13**, 574-583.
- Buzzi, U.H., Stergiou, N., Kurz, M.J., Hageman, P.A. & Heidel, J. (2003). Nonlinear dynamics indicates aging affects variability during gait. *Clinical Biomechanics*, **18**, 435-443.
- Carson, R.G. & Riek, S. (1998). Moving beyond phenomenology: Neuromuscular-skeletal constraints upon coordination dynamics. In *Motor Behavior and Human Skill: A Multidisciplinary Approach* (edited by J.P. Piek), pp. 209-232. Champaign, IL: Human Kinetics.
- Cavanagh, P.R. & Hinrichs, R. (1981). Biomechanics of sport: The state of the art. In *Perspectives of the Academic Discipline of Physical Education* (edited by G.A. Brooks), pp. 137-157. Champaign, IL: Human Kinetics.
- Challis, J.H. (1999). A procedure for the automatic determination of filter cutoff frequency of the processing of biomechanical data. *Journal of Applied Biomechanics*, **15**, 303-317.
- Challis, J.H. & Kerwin, D.G. (1987). An evaluation of splines in biomechanical data analysis. In *Biomechanics XI-B* (edited by G. De Groot, A.P. Hollander, P.A. Huijing & G.J. van Ingen Schenau), pp.1057-1061. Amsterdam: Free University Press.
- Challis, J.H. & Kerwin, D.G. (1992). Accuracy assessment and control point configuration when using the DLT for photogrammetry. *Journal of Biomechanics*, **25**, 1053-1058.
- Chang, R., van Emmerik, R. & Hamill, J. (2008). Quantifying rearfoot-forefoot coordination in human walking. *Journal of Biomechanics*, **41**, 3101-3105.
- Chen, L., Armstrong, C.W. & Raftopoulos, D.D. (1994). An investigation on the accuracy of three-dimensional space reconstruction using the direct linear transformation technique. *Journal of Biomechanics*, **27**, 493-500.
- Chow, J.Y., Davids, K., Button, C. & Koh, M. (2008). Coordination changes in a discrete multi-articular action as a function of practice. *Acta Psychologica*, **127**, 163-176.
- Clark, J.E. (1995). On becoming skillful: Patterns and constraints. *Research Quarterly for Exercise and Sport*, **66**, 173-183.
- Clark, J.E., & Phillips, S.J. (1993). A longitudinal study of intralimb coordination in the first year of independent walking: A dynamical systems analysis. *Child Development*, **64**, 1143-1157.
- Cohen, J. (1988). *Statistical Power Analysis for the Behavioral Sciences* (2nd Edition). Hillsdale, NJ: Erlbaum.

- Coleman, S. (2002). Biomechanics and its application to coaching practice. In *The Coaching Process: Principles and Practice for Sport* (edited by N. Cross & J. Lyle), pp. 130-151. Oxford: Butterworth: Butterworth-Heinemann.
- Cooley, T. (2003). Individuality – pace bowling by Troy Cooley. *Hitting the Seam: The Official Newsletter of the ECB Coach Education Department*, **12**, 7.
- Cooley, T. (2005). Evolution of fast bowling coaching. *ECB CA Coaches Association – Yearbook 2005*, **4**, 41-44.
- Corbetta, D. & Vereijken, B. (1999). Understanding development and learning of motor coordination in sport: The contribution of dynamic systems theory. *International Journal of Sport Psychology*, **30**, 507-530.
- Cronbach, L.J., Nageswari, R. & Gleser, G.C. (1963). Theory of generalizability: A liberation of reliability theory. *The British Journal of Statistical Psychology*, **16**, 137-163.
- Curtin, F. & Schulz, P. (1998). Multiple correlations and Bonferroni's correction. *Biological Psychiatry*, **44**, 775-777.
- Dauids, K. & Glazier, P.S. (2010). Deconstructing neurobiological coordination: The biomechanics-motor control nexus. *Exercise and Sport Sciences Reviews*, **38**, 86-90.
- Dauids, K., Handford, C. & Williams, M. (1994). The natural physical alternative to cognitive theories of motor behaviour: An invitation for interdisciplinary research in sports science? *Journal of Sports Sciences*, **12**, 495-528.
- Dauids, K., Renshaw, I & Glazier, P. (2005). Movement models from sports reveal fundamental insights into coordination processes. *Exercise & Sport Sciences Reviews*, **33**, 36-42.
- Dauids, K., Button, C. & Bennett, S. (2008). *Dynamics of Skill Acquisition: A Constraints-Led Approach*. Champaign, IL: Human Kinetics.
- Dauids, K., Glazier, P.S., Araújo, D. & Bartlett, R.M. (2003). Movement systems as dynamical systems: The role of functional variability and its implications for sports medicine. *Sports Medicine*, **33**, 245-260.
- Davis, K. & Blanksby, B. (1976a). The segmental components of fast bowling in cricket. *Australian Journal for Health, Physical Education and Recreation*, **71** (suppl.), 6-8.
- Davis, K. & Blanksby, B. (1976b). A cinematographical analysis of fast bowling in cricket. *Australian Journal for Health, Physical Education and Recreation*, **71** (suppl.), 9-15.
- Derrick, T.R. & Thomas, J.M. (2004). Time series analysis: The cross-correlation function. In *Innovative Analyses of Human Movement: Analytical Tools for Human Movement Research* (edited by N. Stergiou), pp. 189-205. Champaign, IL: Human Kinetics.
- Devlin, L.H., Fraser, S.F., Barras, N.S. & Hawley, J.A. (2001). Moderate levels of hydration impairs bowling accuracy but not bowling velocity in skilled cricket players. *Journal of Science & Medicine in Sport*, **4**, 179-187.
- Dixon, S.J. & Kerwin, D.G. (2002). Variations in Achilles tendon loading with heel lift intervention in heel-toe runners. *Journal of Applied Biomechanics*, **18**, 321-331.

- Dufek, J.S. & Zhang, S. (1996). Landing models for volleyball players: A longitudinal evaluation. *Journal of Sports Medicine and Physical Fitness*, **36**, 35-42.
- Dufek, J.S., Bates, B.T. & Davis, H.P. (1995). The effect of trial size and variability on statistical power. *Medicine & Science in Sports & Exercise*, **27**, 288-295.
- Dufek, J.S., Bates, B.T., Stergiou, N. & James, C.R. (1995). Interactive effects between group and single-subject response patterns. *Human Movement Science*, **14**, 301-323.
- Duffield, R., Carney, M. & Karppinen, S. (2009). Physiological responses and bowling performance during repeated spells of medium-fast bowling. *Journal of Sports Sciences*, **27**, 27-35.
- Elliott, B.C. (2000). Back injuries and the fast bowler in cricket. *Journal of Sports Sciences*, **18**, 983-991.
- Elliott, B.C. & Foster, D.H. (1984). A biomechanical analysis of the front-on and side-on fast bowling techniques. *Journal of Human Movement Studies*, **10**, 83-94.
- Elliott, B.C., Foster, D.H. & Gray, S. (1986). Biomechanical and physical factors influencing fast bowling. *Australian Journal of Science and Medicine in Sport*, **18**, 16-21.
- Elliott, B.C., Alderson, J. & Reid, M. (2008). Biomechanics of striking and kicking. In *Routledge Handbook of Biomechanics and Human Movement Science* (edited by Y. Hong & R. Bartlett), pp. 311-322. London: Routledge.
- Elliott, B.C., Hardcastle, P.H., Burnett, A.F. & Foster, D.H. (1992). The influence of fast bowling and physical factors on radiological features in high performance young fast bowlers. *Sports Medicine, Training and Rehabilitation*, **3**, 113-130.
- Elliott, B., Wallis, R., Sakurai, S., Lloyd, D. & Besier, T. (2002). The measurement of shoulder alignment in cricket fast bowling. *Journal of Sports Sciences*, **20**, 507-510.
- Engelbrecht, S.E. (2001). Minimum principles in motor control. *Journal of Mathematical Psychology*, **45**, 497-542.
- Ferdinands, R.E.D., Broughan, K.A. & Round, H. (2002). A time-variant forward solution model of the bowling arm in cricket. In *International Research in Sports Biomechanics* (edited by Y. Hong), pp. 56-65. London: Taylor & Francis.
- Ferdinands, R.E.D. & Marshall, R.N. (2004). Bowling arm mechanics in cricket. In *Proceedings of the XXII International Symposium on Biomechanics* (edited by M. Lamontagne, D.G.E. Robertson & H. Sveistrup), pp. 202-205. Ottawa: University of Ottawa.
- Ferdinands, R.E.D., Marshall, R.N., Round, H. & Broughan, K.A.B. (2003). Ball speed generation by fast bowlers in cricket. In *Proceedings of the International Society of Biomechanics XIXth Congress* (edited by P. Milburn, B. Wilson & T. Yanai), Dunedin, NZ: University of Otago.
- Fisher, R.A. (1921). On the probable error of a coefficient of correlation deduced from a small sample. *Metron*, **1**, 1-32.
- Fitch, H., Tuller, B. & Turvey, M.T. (1982). The Bernstein perspective: III. Tuning of coordinative structures with special reference to perception. In *Human Motor Behavior: An Introduction* (edited by J.A.S. Kelso), pp. 271-281. Hillsdale, NJ: Lawrence Erlbaum Associates Inc.

- Fleisig, G.S., Barrentine, S.W., Escamilla, R.F. & Andrews, J.R. (1996). Biomechanics of overhand throwing and implications for injuries. *Sports Medicine*, **21**, 421-437.
- Foster, D.H., John, D., Elliott, B., Ackland, T. & Fitch, K. (1989). Back injuries to fast bowlers in cricket: a prospective study. *British Journal of Sports Medicine*, **23**, 150-154.
- Freeman, H. (1961). A technique for the classification and recognition of geometric patterns. In *Proceedings of the 3rd International Congress on Cybernetics*. Namur, Belgium.
- Gelfand, I.M., Gurfinkel, V.S., Tsetlin, M.L. & Shik, M.L. (1971). Some problems in the analysis of movements. In *Models of the Structural-Functional Organization of Certain Biological Systems* (edited by I.M. Gelfand, V.S. Gurfinkel, S.V. Fomin & M.L. Tsetlin), pp. 329-345. Cambridge, MA: MIT Press.
- Giakas, G. & Baltzopoulos, V. (1997). A comparison of automatic filtering techniques applied to biomechanical walking data. *Journal of Biomechanics*, **30**, 847-850.
- Gittoes, M.J.R. & Kerwin, D.G. (2006). Component inertia modeling of segmental wobbling and rigid masses. *Journal of Applied Biomechanics*, **22**, 148-154.
- Glazier, P.S. (2010a). Game, set and match? Substantive issues and future directions in performance analysis. *Sports Medicine*, **40**, 625-634.
- Glazier, P.S. (2010b). Is the ‘crunch factor’ an important consideration in the aetiology of lumbar spine pathology in cricket fast bowlers? *Sports Medicine*, **40**, 809-815.
- Glazier, P.S. (2011). Movement variability in the golf swing: Theoretical, methodological, and practical issues. *Research Quarterly for Exercise and Sport*, **82**, 157-161.
- Glazier, P.S. & Davids, K. (2009a). The problem of measurement indeterminacy in complex neurobiological movement systems. *Journal of Biomechanics*, **42**, 2694-2696.
- Glazier, P.S. & Davids, K. (2009b). Constraints on the complete optimization of human motion. *Sports Medicine*, **39**, 15-28.
- Glazier, P.S., Paradisis, G.P. & Cobner, D.M. (1999). Validity of the Speedchek™ Personal Sports Radar device using limits of agreement. *Journal of Sports Sciences*, **17**, 986.
- Glazier, P.S., Paradisis, G.P. & Cooper, S-M. (2000). Anthropometric and kinematic influences on release speed in men’s fast-medium bowling. *Journal of Sports Sciences*, **18**, 1013-1024.
- Glazier, P.S., Davids, K. & Bartlett, R.M. (2003). Dynamical systems theory: A relevant framework for performance-oriented sports biomechanics research. *Sportscience*, **7** (<http://www.sportsci.org/>).
- Glazier, P.S., Wheat, J.S., Pease, D.L. & Bartlett, R.M. (2006). The interface of biomechanics and motor control: Dynamic systems theory and the functional role of movement variability. In *Movement System Variability* (edited by K. Davids, S.J. Bennett & K.M. Newell), pp. 49-69. Champaign, IL: Human Kinetics.
- Goodwin, L.D. (2001). Interrater agreement and reliability. *Measurement in Physical Education and Exercise Science*, **5**, 13-34.

- Greene, P.H. (1972). Problems of organization of motor systems. In *Progress in Theoretical Biology – Volume 2* (edited by R. Rosen & F. Snell), pp. 303-338. New York: Academic Press.
- Gregor, R.J. (1989). Locomotion: A commentary. In *Future Directions in Exercise and Sport Science Research* (edited by J.S. Skinner, C.B. Corbin, D.M. Landers, P.E. Martin & C.L. Wells), pp. 195-199. Champaign, IL: Human Kinetics.
- Gregor, R.J. (2008). Interdisciplinary vertical integration: The future of biomechanics. *Quest*, **60**, 31-44.
- Gregor, R.J., Broker, J.P. & Ryan, M.M. (1992). Performance feedback and new advances in biomechanics. In *Enhancing Human Performance in Sport: New Concepts and Developments* (edited by R.W. Christina & H.M. Eckert), pp. 19-32. Champaign, IL: Human Kinetics.
- Gruber, K., Ruder, H., Denoth, J. & Schneider, K. (1998). A comparative study of impact dynamics: Wobbling mass models versus rigid models. *Journal of Biomechanics*, **31**, 439-444.
- Hamill, J., Haddad, J.M. & McDermott, W.J. (2000). Issues in quantifying variability from a dynamical systems perspective. *Journal of Applied Biomechanics*, **16**, 407-418.
- Hamill, J., Haddad, J.M. & van Emmerik, R.E.A. (2006). Overuse injuries in running: Do complex analyses help our understanding? In *Proceedings of XXIV International Symposium on Biomechanics in Sports* (edited by H. Schwameder, G. Strutzenberger, V. Fastenbauer, S. Lindinger & E. Müller), pp. 27-32, Salzburg, Austria: University of Salzburg.
- Hamill, J., van Emmerik, R.E.A., Heiderscheit, B.C. & Li, L. (1999). A dynamical systems approach to lower extremity running injuries. *Clinical Biomechanics*, **14**, 297-308.
- Hanley, B., Lloyd, R. & Bissas, A. (2005). Relationships between ball release velocity and kinematic variables in fast bowling. *Journal of Sports Sciences*, **23**, 111-112.
- Hatze, H. (1976). The complete optimization of a human motion. *Mathematical Biosciences*, **28**, 99-135.
- Hatze, H. (1981). The use of optimally regularized Fourier series for estimating higher-order derivatives of noisy biomechanical data. *Journal of Biomechanics*, **13**, 13-18.
- Hatze, H. (1986). Motion variability – its definition, quantification, and origin. *Journal of Motor Behavior*, **18**, 5-16.
- Hatze, H. (1990). Data conditioning and differentiation techniques. In *Biomechanics of Human Movement: Applications in Rehabilitation, Sports and Ergonomics* (edited by N. Berme & A. Cappozzo), pp. 237-248. Worthington, OH: Bertec Corporation.
- Hatze, H. (1998). Biomechanics of sports: Selected examples of successful applications and future perspectives. In *Proceedings of the XVI International Symposium on Biomechanics in Sports* (edited by H. Riehle & M. Vieten), pp. 2-22. Germany: University of Konstanz.
- Hatze, H. (2000). The inverse dynamics problem of neuromuscular control. *Biological Cybernetics*, **82**, 133-141.

- Hatze, H. (2002). The fundamental problem of myoskeletal inverse dynamics and its implications. *Journal of Biomechanics*, **35**, 109-115.
- Hay, J.G. (1983). Biomechanics of sport: An overview. In *Collected Papers on Sports Biomechanics* (edited by G. Wood), pp. 1-21. Nedlands, WA: University of Western Australia Press.
- Hay, J.G. (1985). Issues in sports biomechanics. In *Biomechanics: Current Interdisciplinary Research* (edited by S.M. Perren & E. Schneider), pp. 49-60. Dordrecht: Martinus Nijhoff.
- Hay, J.G. & Reid, G. (1988). *Anatomy, Mechanics and Human Motion (2nd Edition)*. Englewood Cliffs, NJ: Prentice-Hall.
- Hay, J.G., Wilson, B.D. & Dapena, J. (1976). Identification of the limiting factors in the performance of a basic human movement. In *Biomechanics V-B* (edited by P.V. Komi), pp. 13-19. Baltimore: University Park Press.
- Hay, J.G., Vaughan, C.L. and Woodworth, G.G. (1981). Technique and performance: Identifying the limiting factors. In *Biomechanics VII-B* (edited by A. Morecki, K. Fidelus & A. Wit), pp. 511-520. Baltimore, MD: University Park Press.
- Heuer, H., Schmidt, R.A. & Ghodsian, D. (1995). Generalized motor programs for rapid bimanual tasks: A two-level multiplicative rate model. *Biological Cybernetics*, **73**, 343-356.
- Higgins, S. (1985). Movement as an emergent form: Its structural limits. *Human Movement Science*, **4**, 119-148.
- Hiley, M.J. & Yeadon, M.R. (2005). The margin for error when releasing the asymmetric bars for dismounts. *Journal of Applied Biomechanics*, **21**, 223-235.
- Hodges, N.J. & Franks, I.M. (2002). Modelling coaching practice: The role of instruction and demonstration. *Journal of Sports Sciences*, **20**, 793-811.
- Hopkins, W.G., Marshall, S.W., Batterham, A.M. & Hanin, J. (2008). Progressive statistics for studies in sports medicine and exercise science. *Medicine & Science in Sports & Exercise*, **41**, 3-12.
- Hook, P. (1990). Fast twitch fibres. *The Cricketer*, **71**, 14-15.
- Hreljac, A. (1998). Individual effects on biomechanical variables during landing in tennis shoes with varying midsole density. *Journal of Sports Sciences*, **16**, 531-537.
- Hurrien, P. & Harmer, J. (2003). The fast-medium bowlers: A sports biomechanics and technical model. In *Science and Medicine in Cricket: A Collection of Papers from the Second World Congress of Science and Medicine in Cricket* (edited by R.A. Stretch, T.D. Noakes & C.L. Vaughan) pp.18-28. Port Elizabeth: University of Port Elizabeth.
- Jackson, K.M. (1979). Fitting of mathematical functions to biomechanical data. *IEEE Transactions on Biomedical Engineering*, **26**, 122-124.
- James, C.R. (2004). Considerations of movement variability in biomechanics research. In *Innovative Analyses of Human Movement: Analytical Tools for Human Movement Research* (edited by N. Stergiou), pp. 29-62. Champaign, IL: Human Kinetics.

- James, C.R. & Bates, B.T. (1997). Experimental and statistical design issues in human movement research. *Measurement in Physical Education & Exercise Science*, **1**, 55-69.
- Janssen, D., Schöllhorn, W., Lubienetzki, J., Fölling, K., Kokenge, H. & Davids, K. (2008). Recognition of emotions in gait patterns by means of artificial neural nets. *Journal of Nonverbal Behavior*, **32**, 79-92.
- Janssen, D., Schöllhorn, W.I., Newell, K.M., Jäger, J.M., Rost, F. & Vehof, K. (2011). Diagnosing fatigue in gait patterns by support vector machines and self-organising maps. *Human Movement Science*, **30**, 966-975.
- Jensen, R.K. (1993). Human morphology: Its role in the mechanics of movement. *Journal of Biomechanics*, **26** (suppl.), 81-94.
- Kaufmann, S.A. (1993). *The Origins of Order: Self-Organization and Selection in Evolution*. New York: Oxford University Press.
- Kay, B.A. (1988). The dimensionality of movement trajectories and the degrees of freedom problem: A tutorial. *Human Movement Science*, **7**, 343-364.
- Keele, S.W. (1968). Movement control in skilled motor performance. *Psychological Bulletin*, **70**, 387-403.
- Kelso, J.A.S. (1995). *Dynamics Patterns: The Self-Organization of Brain and Behavior*. Cambridge, MA: MIT Press.
- Kelso, J.A.S., & Schöner, G. (1988). Self-organization of coordinative movement patterns. *Human Movement Science*, **7**, 27-46.
- Kelso, J.A.S., Schöner, G., Scholz, J.P., & Haken, H. (1987). Phase-locked modes, phase transitions and component oscillators in biological motion. *Physica Scripta*, **35**, 79-87.
- King, M.A. & Yeadon, M.R. (2002). Determining subject-specific torque parameters for use in a torque driven simulation model of dynamic jumping. *Journal of Applied Biomechanics*, **18**, 207-217.
- Knudson, D. & Morrison, C. (2002). *Qualitative Analysis of Human Movement (2nd Edition)*. Champaign, IL: Human Kinetics.
- Kohonen, T. (2001). *Self-Organizing Maps*. Berlin: Springer.
- Kugler, P.N., Kelso, J.A.S. & Turvey, M.T. (1980). On the concept of coordinative structures as dissipative structures: I. Theoretical lines of convergence. In *Tutorials in Motor Behavior* (edited by G.E. Stelmach & J. Requin), pp. 3-48. Amsterdam: North-Holland.
- Kugler, P.N. & Turvey, M.T. (1987). *Information, Natural Law, and the Self-Assembly of Rhythmic Movement*. Hillsdale, NJ: Lawrence Erlbaum Associates.
- Kugler, P.N. (1986). A morphological perspective on the origin and evolution of movement patterns. In *Motor Development in Children: Aspects of Coordination and Control* (edited by M.G. Wade & H.T.A. Whiting), pp. 459-525. Dordrecht: Martinus Nijhoff.
- Kurz, M.J. & Stergiou, N. (2002). Effect of normalization and phase angle calculations on continuous relative phase. *Journal of Biomechanics*, **35**, 369-374.
- Kurz, M.J. & Stergiou, N. (2004). Applied dynamic systems theory for the analysis of movement. In *Innovative Analyses of Human Movement: Analytical Tools for*

- Human Movement Research* (edited by N. Stergiou), pp. 93-119. Champaign, IL: Human Kinetics.
- Lamb, P., Bartlett, R. & Robins, A. (2010). Self-organizing maps: An objective method for clustering complex human movement. *International Journal of Computer Science in Sport*, **9**, 20-29.
- Lamb, P., Bartlett, R., Robins, A. & Kennedy, G. (2008). Self-organizing maps as a tool to analyze movement variability. *International Journal of Computer Science in Sport*, **7**, 28-39.
- Latash, M.L., Scholz, J.P. & Schönér, G. (2002). Motor control strategies revealed in the structure of motor variability. *Exercise and Sport Sciences Reviews*, **30**, 26-31.
- Lees, A. (1992). Biomechanics in teaching and coaching: Systematic approaches to the identification of mechanisms in performance and injury. In *Proceedings of the Xth Symposium of the International Society of Biomechanics in Sports* (edited by R. Rodano, G. Ferrigno & G.C. Santambrogio), pp.171-177. Milan: Edi Ermes.
- Lees, A. (1999). Biomechanical assessment of individual sports for improved performance. *Sports Medicine*, **28**, 299-305.
- Lees, A. (2002). Technique analysis in sports: A critical review. *Journal of Sports Sciences*, **20**, 813-828.
- Lees, A. & Barton, G. (2005). A characterisation of technique in the soccer kick using a Kohonen neural network analysis. In *Science and Football V: The Proceedings of the Fifth World Congress on Science and Football* (edited by T. Reilly, J. Cabri & D. Araujo), pp. 83-88. London: Routledge.
- Li, L. & Caldwell, G.E. (1999). Coefficient of cross correlation and the time domain correspondence. *Journal of Electromyography and Kinesiology*, **9**, 385-389.
- Lillee, D. (1977). *The Art of Fast Bowling*. Sydney: Collins.
- Looney, M.A., Smith, S.L. & Srinivasan, S. (1990). Establishing reliability of biomechanical data using univariate and multivariate approaches. *Research Quarterly for Exercise and Sport*, **61**, 154-160.
- Loram, L.C., McKinnon, W., Wormgoor, S., Rogers, G.G., Nowak, I. & Harden, L.M. (2005). Determinants of ball release speed in schoolboy fast-medium bowlers in cricket. *Journal of Sports Medicine and Physical Fitness*, **45**, 483-490.
- Mason, B.R., Weissenteiner, J.R. & Spence, P.R. (1989). Development of a model for cricket fast bowling. *Excel*, **6** (1), 2-12.
- Mann, R. & Herman, J. (1985). Kinematic analysis of Olympic sprint performance: Men's 200 metres. *International Journal of Sport Biomechanics*, **1**, 151-161.
- Marasso, P. (1981). Spatial control of arm movements. *Experimental Brain Research*, **42**, 223-227.
- Marino, G.W. (1983). Selected mechanical factors associated with acceleration in ice skating. *Research Quarterly for Exercise and Sport*, **54**, 234-238.
- Marteniuk, R.G. (1976). *Information Processing in Motor Skills*. New York: Holt, Rinehart & Winston.
- Martin, A.D., Carter, J.E., Hendy, K.C. & Malina, R.M. (1988). Segment lengths. In *Anthropometric Standardization Reference Manual* (edited by T.G. Lohmann, A.F. Roche and R. Martorell), pp. 9-26. Champaign, IL: Human Kinetics.

- Marylebone Cricket Club (2009). *The Laws of Cricket (2000 Code – 3rd Edition)*. London: Marylebone Cricket Club.
- Marzan, G.T. & Karara, H.M. (1975). A computer program for direct linear transformation solution of the colinearity condition and some applications of it. In *Symposium on Close Range Photogrammetric Systems*, pp. 420-476. Fall Church, VA: American Society of Photogrammetry.
- Maynard Smith, J. (1978). Optimization theory in evolution. *Annual Review of Ecology and Systematics*, **9**, 31-56.
- Mazur, J.E. (1983). Optimization: A result or a mechanism? *Science*, **221**, 977.
- McCaw, S.T., & DeVita, P. (1995). Errors in alignment of center of pressure and foot coordinates affect predicted lower extremity torques. *Journal of Biomechanics*, **28**, 985-988.
- McDonald, P.V., van Emmerik, R.E.A. & Newell, K.M. (1989). The effects of practice on limb kinematics in a throwing task. *Journal of Motor Behavior*, **21**, 245-264.
- McGarry, T. (2009). Applied and theoretical perspectives of performance analysis in sport: Scientific issues and challenges. *International Journal of Performance Analysis of Sport*, **9**, 128-140.
- McLaughlin, T.M., Dillman, C.J. & Lardner, T.J. (1977). Biomechanical analysis with cubic spline functions. *Research Quarterly*, **48**, 569-582.
- McGinnis, P.M. & Newell, K.M. (1982). Topological dynamics: A framework for describing movement and its constraints. *Human Movement Science*, **1**, 289-305.
- Michaels, C.F. & Beek, P.J. (1996). The state of ecological psychology. *Ecological Psychology*, **7**, 259-278.
- Miller, D.I. (1979). Modelling in biomechanics: An overview. *Medicine and Science in Sports*, **11**, 115-122.
- Miller, D.I. (1980). Body segment contributions to sport skill performance: Two contrasting approaches. *Research Quarterly for Exercise and Sport*, **51**, 219-233.
- Millet, G.Y., Divert, C., Banizette, M. & Morin, J-B. (2010). Changes in running pattern due to fatigue and cognitive load in orienteering. *Journal of Sports Sciences*, **28**, 153-160.
- Milner, C.E. (2008). Motion analysis using on-line systems. In *Biomechanical Evaluation of Movement in Sport and Exercise: British Association of Sport and Exercise Sciences Guidelines* (edited by C.J. Payton & R.M. Bartlett), pp. 33-52. London: Routledge.
- Müller, W., Platzer, D. & Schmolzer, B. (1996). Dynamics of human flight on skis: improvements in safety and fairness in ski jumping. *Journal of Biomechanics*, **29**, 1061-1068.
- Mullineaux, D.R., Bartlett, R.M. & Bennett, S.J. (2001). Research design and statistics in biomechanics and motor control. *Journal of Sports Sciences*, **19**, 739-760.
- Newell, K.M. (1985). Coordination, control and skill. In *Differing Perspectives in Motor Learning, Memory and Control* (edited by D. Goodman, R.B. Wilberg & I.M. Franks), pp. 295-317. Amsterdam: North-Holland.
- Newell, K.M. (1986). Constraints on the development of coordination. In *Motor Development in Children: Aspects of Coordination and Control* (edited by M.G. Wade & H.T.A. Whiting), pp. 341-360. Dordrecht: Martinus Nijhoff.

- Newell, K.M. (1996). Change in movement and skill: Learning, retention, and transfer. In *Dexterity and its Development* (edited by M.L. Latash & M.T. Turvey), pp. 393-429. Mahwah, NJ: Erlbaum Associates.
- Newell, K.M. & McDonald, P.V. (1992). Practice: A search for task solutions. In *Enhancing Performance in Sport: New Concepts and Developments* (edited by R.W. Christina & H.M. Eckert), pp. 51-59. Champaign, IL: Human Kinetics.
- Newell, K.M. & Morrison, S. (1996). Frames of reference and normal movement. *Behavioral and Brain Sciences*, **19**, 83-84.
- Newell, K.M. & Slifkin, A.B. (1998). The nature of movement variability. In *Motor Behavior and Human Skill: A Multidisciplinary Approach* (edited by J.P. Piek), pp. 143-160. Champaign, IL: Human Kinetics.
- Newell, K.M. & Jordan, K. (2007). Task constraints and movement organization: A common language. In *Ecological Task Analysis and Movement* (edited by W.E. Davis & G.D. Broadhead), pp. 5-23. Champaign, IL: Human Kinetics.
- Newell, K.M. & Ranganathan, R. (2010). Instructions as constraints in motor skill acquisition. In *Motor Learning in Practice: A Constraints-Led Approach* (edited by I. Renshaw, K. Davids & G.J.P. Savelsbergh), pp. 17-32. London: Routledge.
- Newell, K.M., McDonald, P.V. & Kugler, P.N. (1991). The perceptual-motor workspace and the acquisition of skill. In *Tutorials in Motor Neuroscience* (edited by J. Requin & G.E. Stelmach), pp. 95-108. Dordrecht: Kluwer.
- Newell, K.M., Mayer-Kress, G. & Liu, Y-T. (2001). Time scales in motor learning and development. *Psychological Review*, **108**, 57-82.
- Newell, K.M., van Emmerik, R.E.A. & McDonald, P.V. (1989). Biomechanical constraints and action theory: Reaction to G.J. van Ingen Schenau (1989). *Human Movement Science*, **8**, 403-409.
- Newell, K.M., Kugler, P.N., van Emmerik, R.E.A. & McDonald, P.V. (1989). Search strategies and the acquisition of coordination. In *Perspective on the Coordination of Movement* (edited by S.A. Wallace), pp. 85-122. Amsterdam: North-Holland.
- Norman, R.W. (1989). A barrier to understanding human motion mechanisms: A commentary. In *Future Directions in Exercise and Sport Science Research* (edited by J.S. Skinner, C.B. Corbin, D.M. Landers, P.E. Martin and C.L. Wells), pp. 151-161. Champaign, IL: Human Kinetics.
- Orchard, J., James, T., Alcott, E., Carter, S. & Farhart, P. (2002). Injuries in Australian cricket at first class level 1995/1996 to 2000/2001. *British Journal of Sports Medicine*, **36**, 270-274.
- Payton, C.J. & Bartlett, R.M. (eds.) (2008). *Biomechanical Evaluation of Movement in Sport and Exercise: The British Association of Sport and Exercise Sciences Guidelines*. London: Routledge.
- Penrose, T., Foster, D. & Blanksby, B. (1976). Release velocities of fast bowlers during a cricket test match. *Australian Journal for Health, Physical Education and Recreation*, **71** (suppl.), 2-5.
- Peters, B.T., Haddad, J.M., Heiderscheit, B.C., van Emmerik, R.E.A. & Hamill, J. (2003). Limitations in the use and interpretation of continuous relative phase. *Journal of Biomechanics*, **36**, 271-274.

- Petersen, C.J., Wilson, B.D. & Hopkins, W.G. (2004). Effects of modified-implementation training on fast bowling in cricket. *Journal of Sports Sciences*, **22**, 1035-1039.
- Phillips, E., Davids, K., Renshaw, I. & Portus, M. (2010). Expert performance in sport and the dynamics of talent development. *Sports Medicine*, **40**, 271-283.
- Phillips, E., Portus, M., Davids, K. & Renshaw, I. (2012). Performance accuracy and functional variability in elite and developing fast bowlers. *Journal of Science and Medicine in Sport*, **15**, 182-188.
- Plagenhoef, S. (1971). *Patterns of Human Motion: A Cinematographic Analysis*. Englewood, NJ: Prentice-Hall.
- Pohl, M.B. & Buckley, J.G. (2008). Changes in foot and shank coupling due to alterations in foot strike pattern during running. *Clinical Biomechanics*, **23**, 334-341.
- Pont, I. (2006). *The Fast Bowler's Bible*. Marlborough: Crowood Press.
- Porter, R. (1999). *The Greatest Benefit to Mankind*. London: HarperCollins.
- Portus, M.R., Sinclair, P.J., Burke, S.T., Moore, D.J.A. & Farhart, P.J. (2000). Cricket fast bowling performance and technique and the influence of selected physical factors during an 8-over spell. *Journal of Sports Sciences*, **18**, 999-1011.
- Portus, M.R., Mason, B.R., Elliott, B.C., Pfitzner, M.C. & Done, R.P. (2004). Technique factors related to ball release speed and trunk injuries in high performance cricket fast bowlers. *Sports Biomechanics*, **3**, 263-283.
- Prilutsky, B.I. and Zatsiorsky, V.M. (2002). Optimization-based models of muscle coordination. *Exercise and Sport Sciences Reviews*, **30**, 32-38.
- Ranson, C.A., Burnett, A.F., King, M., Patel, N. & O'Sullivan, P.B. (2008). The relationship between bowling action classification and three-dimensional lower trunk motion in fast bowlers in cricket. *Journal of Sports Sciences*, **26**, 267-276.
- Reboussin, D.M. & Morgan, T.M. (1996). Statistical considerations in the use and analysis of single-subject designs. *Medicine & Science in Sports & Exercise*, **28**, 639-644.
- Richards, J.G. (1999). The measurement of human motion: A comparison of commercially available systems. *Human Movement Science*, **18**, 589-602.
- Riley, M.A. & Turvey, M.T. (2002). Variability and determinism in motor behavior. *Journal of Motor Behavior*, **34**, 99-125.
- Roebroeck, M.E., Harlaar, J. & Lankhorst, G.J. (1993). The application of generalizability theory to reliability assessment: An illustration using isometric force measurements. *Physical Therapy*, **73**, 386-395.
- Rosenbaum, D.A. (1998). Is dynamical systems modeling just curve fitting? *Motor Control*, **2**, 101-104.
- Ross, W.D. & Marfell-Jones, M.J. (1991). Kinanthropometry. In *Physiological Testing of the High Performance Athlete* (edited by J.D. McDougall, H.A. Wenger & H.J. Green), pp. 223-308. Champaign, IL: Human Kinetics.
- Salo, A. & Grimshaw, R.N. (1998). An examination of kinematic variability of motion analysis in sprint hurdles. *Journal of Applied Biomechanics*, **14**, 211-222.

- Salter, C.W., Sinclair, P.J. & Portus, M.R. (2007). The associations between fast bowling technique and ball release speed: A pilot study of the within-bowler and between-bowler approaches. *Journal of Sports Sciences*, **25**, 1279-1285.
- Sanders, R.H. (1999). A model of kinematic variables determining height achieved in water polo boosts. *Journal of Applied Biomechanics*, **15**, 270-283.
- Schmidt, R.A. (1982). Generalized motor programs and schemas for movement. In *Human Motor Behavior: An Introduction* (edited by J.A.S. Kelso), pp. 187-235. Hillsdale, NJ: Lawrence Erlbaum Associates Ltd.
- Schmidt, R.A. (1985). The search for invariance in skilled movement behavior. *Research Quarterly for Exercise and Sport*, **56**, 188-200.
- Schöllhorn, W. (2003). Coordination dynamics and its consequence on sports. *International Journal of Computer Science in Sport*, **2**, 40-46.
- Schöllhorn, W. & Bauer, H.U. (1998). Identifying individual movement styles in high performance sports by means of Self-Organizing Kohonen maps. In *Proceedings of the XVI International Symposium on Biomechanics in Sports* (edited by H. Riehle & M. Vieten), pp. 574-577. Germany: University of Konstanz.
- Schöllhorn, W., Nigg, B.M., Stefanyshyn D.J. & Liu, W. (2002). Identification of individual walking patterns using time discrete and time continuous data sets. *Gait & Posture*, **15**, 180-186.
- Schöllhorn, W.I., Mayer-Kress, G., Newell, K.M. & Michelbrink, M. (2009). Time scales of adaptive behaviour and motor learning in the presence of stochastic perturbations. *Human Movement Science*, **28**, 319-333.
- Schöllhorn, W.I., Beckmann, H., Michelbrink, M., Sechelmann, M., Trockel, M. & Davids, K. (2006). Does noise provide a basis for the unification of motor learning theories? *International Journal of Sport Psychology*, **37**, 186-206.
- Scholz, J.P., & Kelso, J.A.S. (1989). A quantitative approach to understanding the formation and change of coordinated movement patterns. *Journal of Motor Behavior*, **21**, 122-144.
- Shapiro, R. (1978). Direct linear transformation method for three-dimensional cinematography. *Research Quarterly*, **49**, 197-205.
- Shemmell, J., Tresilian, J.R., Riek, S. & Carson, R.G. (2004). Musculoskeletal constraints on the acquisition of motor skills. In *Skill Acquisition in Sport: Research, Theory and Practice* (edited by A.M. Williams & N.J. Hodges), pp. 390-408. London: Routledge.
- Shephard, R.J. (1998). Assumptions inherent in biological research. *Adapted Physical Activity Quarterly*, **15**, 222-235.
- Sidaway, B., Heise, G. & Schoenfelder-Zohdi, B. (1995). Quantifying the variability of angle-angle plots. *Journal of Human Movement Studies*, **29**, 181-197.
- Siefert, M., Kittel, A., Friedrich, R. & Peinke, J. (2003). On a quantitative method to analyze dynamical and measurement noise. *Europhysics Letters*, **61**, 466-472.
- Silver, N.C. & Dunlap, W.P. (1987). Averaging correlation coefficients: Should Fisher's Z transformation be used? *Journal of Applied Psychology*, **72**, 146-148.
- Smith, G. (1989). Padding point extrapolation techniques for the Butterworth digital filter. *Journal of Biomechanics*, **22**, 967-971.

- Snook, G.A. (1978). The father of sports medicine. *American Journal of Sports Medicine*, **6**, 128-131.
- Sparrow, W.A. (1992). Measuring changes in coordination and control. In *Approaches to the Study of Motor Control and Learning* (edited by J.J. Summers), pp. 147-162. Amsterdam: Elsevier.
- Sparrow, W.A. (ed.) (2000). *Energetics of Human Activity*. Champaign, IL: Human Kinetics.
- Sparrow, W.A. & Newell, K.M. (1998). Metabolic energy expenditure and the regulation of movement economy. *Psychonomic Bulletin & Review*, **5**, 173-196.
- Sparrow, W.A. & Sherman, C. (2001). Visual expertise in the perception of action. *Exercise and Sport Sciences Reviews*, **29**, 124-128.
- Sparrow, W.A., Donovan, E., van Emmerik, R.E.A. & Barry, E.B. (1987). Using relative motion plots to measure changes in intra-limb and inter-limb coordination. *Journal of Motor Behavior*, **19**, 115-129.
- Staddon, J.E.R. & Hinson, J.M. (1983). Optimization: A result or a mechanism? *Science*, **221**, 976-977.
- Stamm, C.L. & Moore, J.E. (1980). Application of generalizability theory in estimating the reliability of a motor performance test. *Research Quarterly for Exercise and Sport*, **51**, 382-388.
- Stergiou, N., Jensen, J.L., Bates, B.T., Scholten, S.D. & Tzetzis, G. (2001). A dynamical systems investigation of lower extremity coordination during running over obstacles. *Clinical Biomechanics*, **16**, 213-221.
- Stockill, N.P. & Bartlett, R.M. (1992a). A three-dimensional cinematographical analysis of the techniques of International and English county cricket fast bowlers. In *Proceedings of the Xth Symposium of the International Society of Biomechanics in Sports* (edited by R. Rodano, G. Ferrigno and G.C. Santambrogio), pp.52-55. Milan: Edi Ermes.
- Stockill, N.P. & Bartlett, R.M. (1992b). Progress report on the National Cricket Association sport science support programme fast bowling project. *Cricket Coach*, **22**, 1165-1172.
- Stockill, N.P. & Bartlett, R.M. (1994). An investigation into the important determinants of ball release speed in junior and senior international cricket bowlers. *Journal of Sports Sciences*, **12**, 177-178.
- Stockill, N.P. & Bartlett, R.M. (1996). Possible errors in measurement of shoulder alignment using 3-D cinematography. In *Proceedings of the XIVth International Symposium on Biomechanics in Sports* (edited by J.M.C.S. Abrantes), pp. 209-212. Portugal: Edicoes FMH.
- Stretch, R.A. (2003). Cricket injuries: A longitudinal study of the nature of injuries to South African cricketers. *British Journal of Sports Medicine*, **37**, 250-253.
- Stuelcken, M.C., Ferdinands, R.E.D. & Sinclair, P.J. (2010). Three-dimensional trunk kinematics and low back pain in elite female fast bowlers. *Journal of Applied Biomechanics*, **25**, 52-61.
- Takei, Y. (1998). Three-dimensional analysis of handspring with full turn vault: Deterministic model, coaches' beliefs, and judges' scores. *Journal of Applied Biomechanics*, **14**, 190-210.

- Taliep, M.S., Gray, J., St Clair Gibson, A., Calder, S., Lambert, M.I. & Noakes, T.D. (2003). The effects of a 12-over bowling spell on bowling accuracy and pace in cricket fast bowlers. *Journal of Human Movement Studies*, **45**, 197-217.
- Temprado, J., Della-Graza, M., Farrell, M. & Laurent, M. (1997). A novice-expert comparison of (intra-limb) coordination subserving the volleyball serve. *Human Movement Science*, **16**, 653-676.
- Tepavac, D. & Field-Fote, E.C. (2001). Vector coding: A technique for quantification of intersegmental coupling in multicyclic behaviors. *Journal of Applied Biomechanics*, **17**, 259-270.
- Thelen, E. (1995). Motor development: A new synthesis. *American Psychologist*, **50**, 79-95.
- Thelen, E. & Smith, L.B. (1994). *A Dynamic Systems Approach to the Development of Cognition and Action*. Cambridge, MA: MIT Press.
- Thomas, J.R., Salazar, W. & Landers, D.M. (1991). What is missing in $p < .05$? Effect size. *Research Quarterly for Exercise and Sport*, **62**, 344-348.
- Thomas, J.R., Nelson, J.K., & Silverman, S.J. (2005). *Research Methods in Physical Activity (5th edition)*. Champaign, IL: Human Kinetics.
- Todorov, E. (2004). Optimality principles in sensorimotor control. *Nature Neuroscience*, **7**, 907-915.
- Tolson, H. (1980). An adjunct to statistical significance: ω^2 . *Research Quarterly for Exercise and Sport*, **51**, 580-584.
- Tuller, B., Turvey, M.T. & Fitch, H. (1982). The Bernstein perspective: II. The concept of muscle linkage or coordinative structure. In *Human Motor Behavior: An Introduction* (edited by J.A.S. Kelso), pp. 253-270. Hillsdale, NJ: Lawrence Erlbaum Associates Inc.
- Turvey, M.T. (1977). Preliminaries to a theory of action with reference to vision. In *Perceiving, Acting, and Knowing* (edited by R. Shaw & J. Bransford), pp. 211-265. Hillsdale, NJ: Lawrence Erlbaum Associates Inc.
- Turvey, M.T. (1990). Coordination. *American Psychologist*, **45**, 938-953.
- van Emmerik, R.E.A., Hamill, J. & McDermott, W.J. (2005). Variability and coordinative function in human gait. *Quest*, **57**, 102-123.
- Vaughan, C.L. (1982). Smoothing and differentiation of displacement-time data: An application of splines and digital filtering. *International Journal of Biomedical Computing*, **13**, 375-386.
- Vaughan, C.L. (1996). Are joint torques the Holy Grail of human gait analysis? *Human Movement Science*, **15**, 423-443.
- Vesanto, J., Himberg, J., Alhoniemi, E. & Parhankangas, J. (2000). *SOM Toolbox for Matlab 5*. Espoo: Helsinki University of Technology.
- Vereijken, B. & Whiting, H.T.A. (1990). In defence of discovery learning. *Canadian Journal of Sport Sciences*, **15**, 99-106.
- Vincent, W.J. (2005). *Statistics in Kinesiology (3rd Edition)*. Champaign, IL: Human Kinetics.

- Vint, P.F. & Hinrichs, R.N. (1996). Endpoint error in smoothing and differentiating raw kinematic data: An evaluation of four popular methods. *Journal of Biomechanics*, **29**, 1637-1642.
- Wagenaar, R.C. & van Emmerik, R.E.A. (2000). Resonant frequencies of arms and legs identify different walking patterns. *Journal of Biomechanics*, **33**, 853-861.
- Wallace, S.A. (1996). Dynamic pattern perspective of rhythmic movement: An introduction. In *Advances in Motor Learning and Control* (edited by H.N. Zelaznik), pp. 155-194. Champaign, IL: Human Kinetics.
- Weatherley, C., Hardcastle, P., Foster, D. & Elliott, B. (1996). Cricket. In *The Spine in Sports* (edited by R. Watkins), pp.414-429. St Louis, MO: Mosby.
- Weeks, D.J. & Proctor, R.W. (1991). Ecological and process approaches to skill acquisition. *Journal of Human Movement Studies*, **20**, 291-296.
- Welch, B.L. (1951). On the comparison of several mean values: An alternative approach. *Biometrika*, **38**, 330-336.
- Wheat, J.S. & Glazier, P.S. (2006). Measuring coordination and variability in coordination. In *Movement System Variability* (edited by K. Davids, S.J. Bennett & K.M. Newell), pp. 167-181. Champaign, IL: Human Kinetics.
- Wheat, J.S., Bartlett, R.M., Milner, C.E. & Mullineaux, D.R. (2003). The effect of different surfaces on ground reaction forces during running: A single-individual design approach. *Journal of Human Movement Studies*, **44**, 353-364.
- Whiting, W.C. & Zernicke, R.F. (1982). Correlation of movement patterns via pattern recognition. *Journal of Motor Behavior*, **14**, 135-142.
- Wilcox, R.R. (1987). New designs in analysis of variance. *Annual Review of Psychology*, **38**, 29-60.
- Wilson, C., Yeadon, M.R. & King, M.A. (2007). Considerations that affect simulation in a running jump for height. *Journal of Biomechanics*, **40**, 3155-3161.
- Winter, D.A. (1984). Kinematic and kinetic patterns in human gait: Variability and compensating effects. *Human Movement Sciences*, **3**, 51-76.
- Winter, D.A. (1987). Are hypotheses really necessary in motor control research? *Journal of Motor Behavior*, **19**, 276-279.
- Winter, D.A. (1989). Biomechanics of normal and pathological gait: Implications for understanding human locomotor control. *Journal of Motor Behavior*, **21**, 337-355.
- Winter, D.A. (2005). *Biomechanics and Motor Control of Human Movement (3rd Edition)*. Hoboken, NJ: Wiley.
- Winter, D.A., Sidwall, H.G. & Hobson, D.A. (1974). Measurement and reduction of noise in kinematics of locomotion. *Journal of Biomechanics*, **7**, 157-159.
- Woltring, H.J. (1995). On optimal smoothing and derivative estimation from noisy displacement data in biomechanics. *Human Movement Science*, **4**, 229-245.
- Wood, G.A. (1982). Data smoothing and differentiation procedures in biomechanics. *Exercise and Sports Sciences Reviews*, **10**, 308-362.
- Wood, G.A. & Jennings, L.S. (1979). On the use of spline functions for data smoothing. *Journal of Biomechanics*, **12**, 477-479.

- Wood, G.A. & Marshall, R.N. (1986). The accuracy of DLT extrapolation in three-dimensional film analysis. *Journal of Biomechanics*, **19**, 781-785.
- Wormgoor, S., Harden, L. & McKinon, W. (2008). The determinants of ball release speed in cricket fast bowlers. In *Proceedings of the XXVIth International Symposium on Biomechanics in Sports* (edited by Y-H. Kwon, J. Shim, J.K. Shim & I-S. Shin), pp. 136-139. Seoul, Korea: Seoul National University.
- Wright, I.C., Neptune, R.R., van den Bogert, A.J. & Nigg, B.M. (1998). Passive regulation of impact forces in heel-toe running. *Clinical Biomechanics*, **13**, 521-531.
- Yeadon, M.R. (1990). The simulation of aerial movement II: A mathematical inertia model of the human body. *Journal of Biomechanics*, **23**, 67-74.
- Yeadon, M.R. & Challis, J.H. (1994). The future of performance-related sports biomechanics research. *Journal of Sports Sciences*, **12**, 3-32.
- Yeadon, M.R. & King, M.A. (1999). A method for synchronising digitised video data. *Journal of Biomechanics*, **32**, 983-986.
- Yeadon, M.R., King, M.A. & Wilson, C. (2006). Modelling the maximum voluntary joint torque/angular velocity relationship in human movement. *Journal of Biomechanics*, **39**, 476-482.
- Young, M. & Li, L. (2004). Determination of the critical parameters among elite female shot putters. *Sports Biomechanics*, **4**, 131-148.
- Zajac, F.E., & Gordon, M.E. (1989). Determining muscle's force and action in multiarticular movement. *Exercise & Sports Sciences Reviews*, **17**, 187-230.
- Zatsiorsky, V.M. and Fortney, V.L. (1993). Sport biomechanics 2000. *Journal of Sports Sciences*, **11**, 279-283.
- Zernicke, R.F., Caldwell, G. & Roberts, E.M. (1976). Fitting biomechanical data with cubic spline functions. *Research Quarterly*, **47**, 9-19.

Word Count: circa. 43,600

Appendix A
Informed Consent Proforma

INFORMED CONSENT PROFORMA

I certify that I am fully coherent with the verbal explanation of the testing procedures that I am about to undertake. I believe that my current health status is at a suitable level for me to perform maximally if required. I also understand that I am free to leave the testing environment, at any time, without prejudice. All data gained from the study will be kept in confidence and will be made available to the participants involved post-testing.

Participant Name (printed):

Date of Birth:

Signature:

Height (m):

Mass (kg):

This document has been constructed to the guidelines set out by the British Association of Sport and Exercise Sciences (BASES) and the UWIC Ethics Committee.

Appendix B

User-Defined Spatial Model of the Human Performer

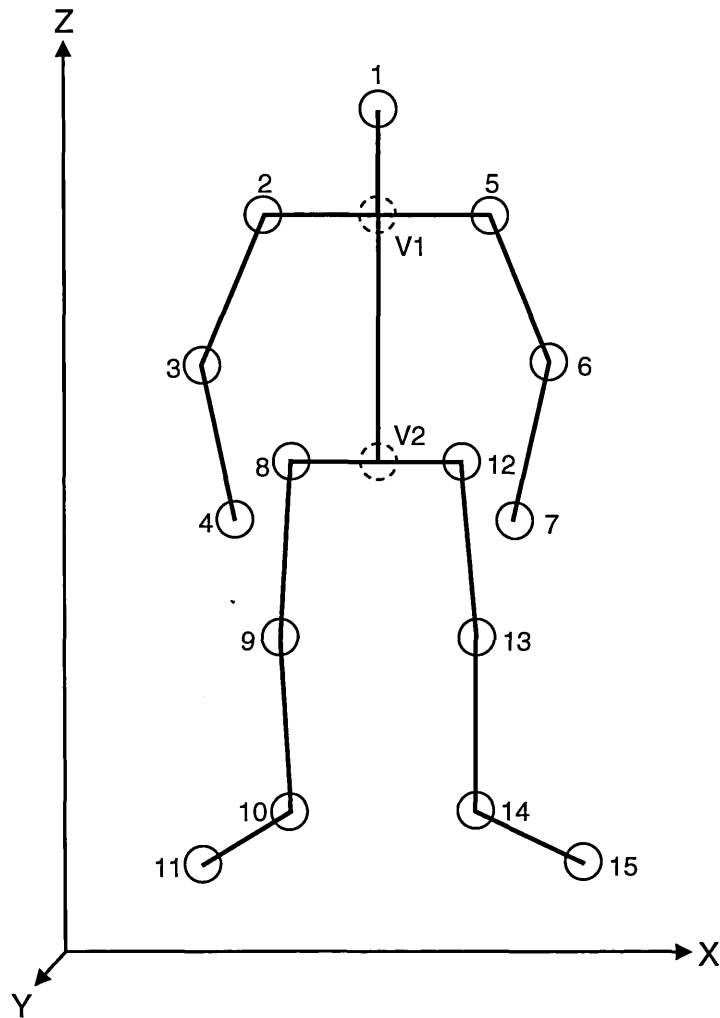

Figure B.1. The user-defined 15-point, 14-segment spatial model used to reconstruct the human performer. \circ and \odot denote a digitised landmark and a virtual marker, respectively. Virtual markers for the upper torso (V1) and pelvis (V2) were defined as the mid-way point between markers 2 and 5 and 8 and 12, respectively.

Table B.1. Body segment definitions.

Marker	Landmark	Vector	Segment
1	Head	V1→1	Head and Neck
2	Right Shoulder	V2→V1	Trunk
3	Right Elbow	5→2	Upper Torso
4	Right Wrist	12→8	Pelvis
5	Left Shoulder	2→3	Right Upper Arm
6	Left Elbow	3→4	Right Lower Arm
7	Left Wrist	5→6	Left Upper Arm
8	Right Hip	6→7	Left Lower Arm
9	Right Knee	8→9	Right Thigh
10	Right Ankle	9→10	Right Shank
11	Right Toe	10→11	Right Foot
12	Left Hip	12→13	Left Thigh
13	Left Knee	13→14	Left Shank
14	Left Ankle	14→15	Left Foot
15	Left Toe		

Appendix C

Root-Mean-Square (RMS) Calibration and Reconstruction Error Estimates

Table C.1. Direct linear transformation RMS error estimates for the individual control points obtained from the DLT residuals

Control Point	X	Y	Z
1	0.001	0.001	0.001
2	0.005	0.000	0.001
3	0.003	0.001	0.001
4	0.002	0.002	0.002
5	0.002	0.002	0.004
6	0.003	0.002	0.001
7	0.003	0.002	0.002
8	0.002	0.000	0.001
9	0.004	0.002	0.001
10	0.001	0.002	0.001
11	0.003	0.000	0.001
12	0.003	0.002	0.001
13	0.001	0.002	0.001
14	0.004	0.002	0.002
15	0.000	0.002	0.001
16	0.001	0.000	0.003
17	0.001	0.003	0.002
18	0.003	0.002	0.001
Average	0.0023	0.0015	0.0018

Table C.2. Average global RMS error estimates obtained from the four direct linear transformation planes over all digitised anatomical landmarks over all video fields. Data obtained from:

(a) 12 re-digitisations of trial 2 performed by participant 7;

Re-digitisation	RMS (m)
1	0.0123
2	0.0113
3	0.0117
4	0.0120
5	0.0115
6	0.0120
7	0.0122
8	0.0123
9	0.0115
10	0.0116
11	0.0116
12	0.0113
Average	0.0118
SD	0.0004

and (b), digitisations of 12 trials from 8 participants.

Trial	Participant							
	1	2	3	4	5	6	7	8
1	0.0107	0.0090	0.0099	0.0090	0.0102	0.0091	0.0123	0.0105
2	0.0107	0.0094	0.0102	0.0073	0.0089	0.0092	0.0112	0.0110
3	0.0101	0.0081	0.0119	0.0077	0.0095	0.0094	0.0116	0.0106
4	0.0092	0.0094	0.0108	0.0083	0.0089	0.0107	0.0110	0.0107
5	0.0093	0.0096	0.0103	0.0083	0.0087	0.0093	0.0109	0.0128
6	0.0092	0.0100	0.0121	0.0076	0.0095	0.0134	0.0111	0.0104
7	0.0103	0.0086	0.0104	0.0083	0.0086	0.0098	0.0118	0.0108
8	0.0104	0.0090	0.0107	0.0085	0.0099	0.0100	0.0116	0.0113
9	0.0098	0.0094	0.0101	0.0077	0.0095	0.0108	0.0110	0.0108
10	0.0099	0.0092	0.0108	0.0074	0.0090	0.0097	0.0117	0.0109
11	0.0105	0.0091	0.0102	0.0082	0.0099	0.0100	0.0126	0.0107
12	0.0104	0.0088	0.0100	0.0081	0.0092	0.0111	0.0190	0.0160
Average	0.0100	0.0091	0.0106	0.0080	0.0092	0.0103	0.0122	0.0115
SD	0.0006	0.0005	0.0007	0.0004	0.0005	0.0012	0.0022	0.0016

Appendix D

Time-Discrete Performance Parameter Definitions

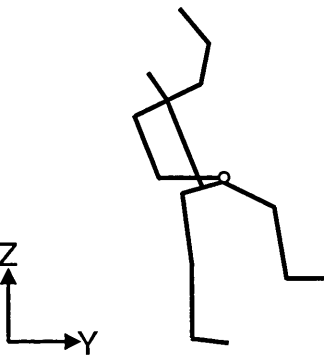
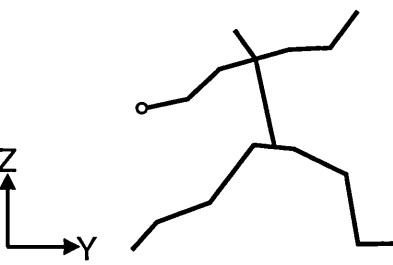
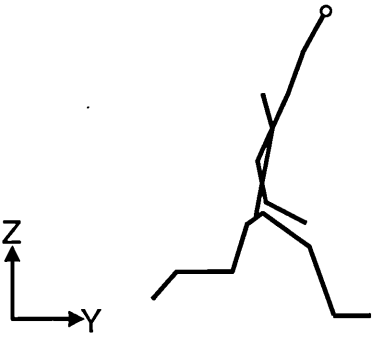
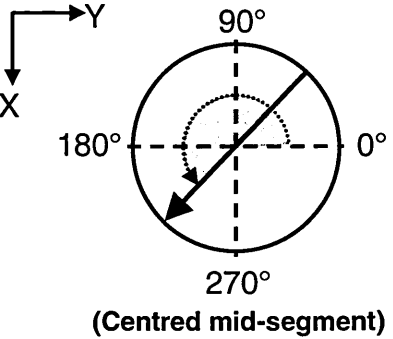
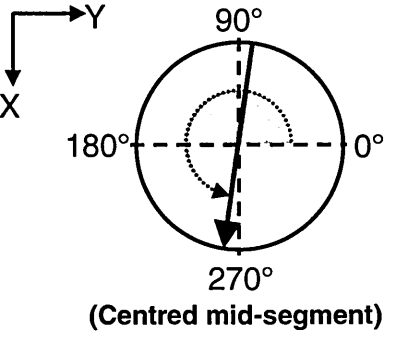
Key moments	
<p>Back foot impact (BFI): The instant when the angle between the vector adjoining the right ankle joint and the distal end of the right foot and the transverse plane defined by the playing surface was minimised.</p>	
<p>Front foot impact (FFI): The instant when the angle between the vector adjoining the left ankle joint and the distal end of the left foot and the transverse plane defined by the playing surface was minimised.</p>	
<p>Ball Release (BR): The instant when the z-y trajectories of the wrist joint centre and the ball centre started to diverge.</p>	
Performance Parameters	
<p>Upper Torso Alignment: The angle between the vector defining the upper torso segment projected onto the transverse plane and the y-axis.</p>	 <p>(Centred mid-segment)</p>
<p>Pelvis Alignment: The angle between the vector defining the pelvis segment projected onto the transverse plane and the y-axis.</p>	 <p>(Centred mid-segment)</p>

Back Foot Alignment: The angle between the vector defining the right foot segment and the sagittal plane.

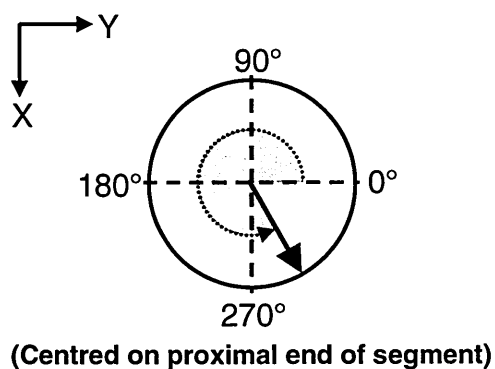

Centre of Mass (COM) Horizontal Velocity: The instantaneous magnitude of the COM along the y-axis.

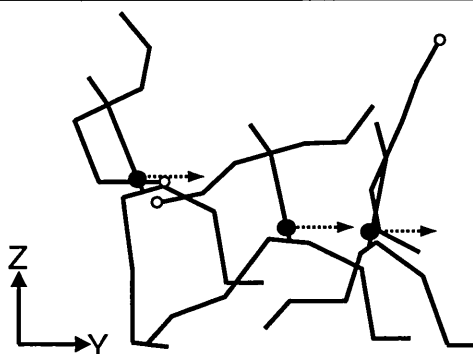

Trunk Flexion-Extension: The angle between the vector defining the trunk segment projected onto the sagittal plane and the y-axis. A negative angle denotes a lean away from the target and a positive angle denotes a lean towards the target.

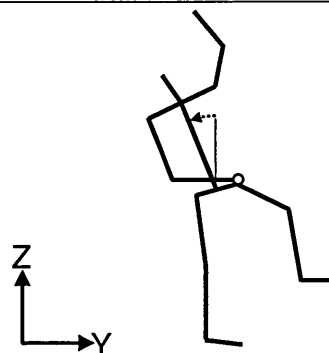

Front Knee Angle: The angle between the vector defining the left thigh segment and the vector defining the left shank segment.

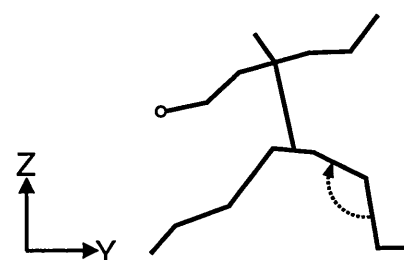

Trunk Lateral Flexion: The angle between the vector defining the trunk projected onto the frontal plane and the x-axis.

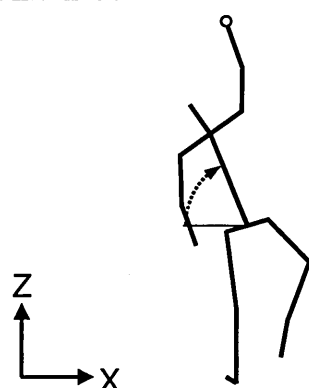

Non-Bowling Arm to Horizontal: The angle between the vector defining the left upper arm and the y-axis.

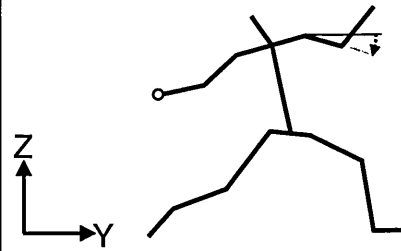

Bowling Arm to Horizontal: The angle between the vector defining the right upper arm and the y-axis.

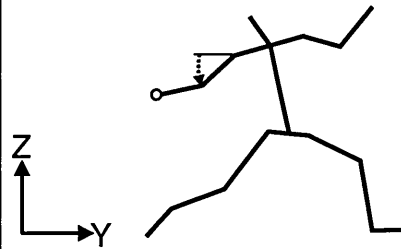

Height of Ball Release: The distance between the centre of the ball and the playing surface at the moment of ball release along the z-axis.

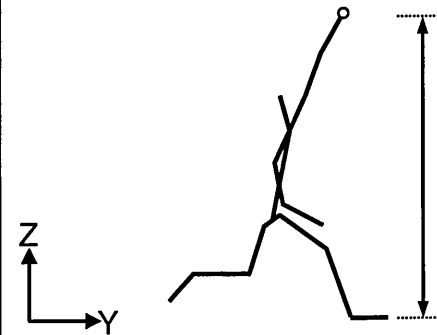

Delivery Stride Length: The distance between the right ankle joint centre at BFI and the left ankle joint centre at FFI along the y-axis.

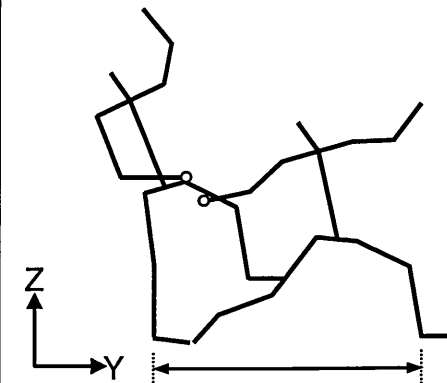

Delivery Stride Alignment: The angle between the vector adjoining the right ankle joint centre at BFI and the left ankle joint centre at FFI and the y-axis.

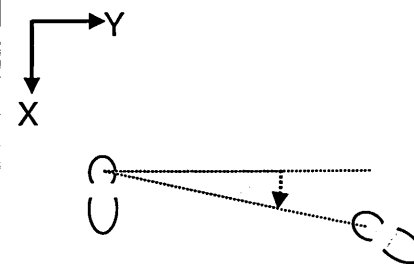

Maximum Right Hip Speed: The maximum speed of the right hip joint centre along the y-axis during the period between BFI and BR.

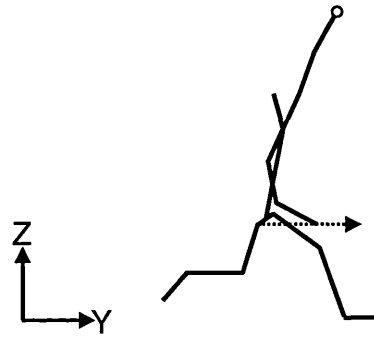

Maximum Right Shoulder Speed: The maximum speed of the right shoulder joint centre along the y-axis during the period between BFI and BR.

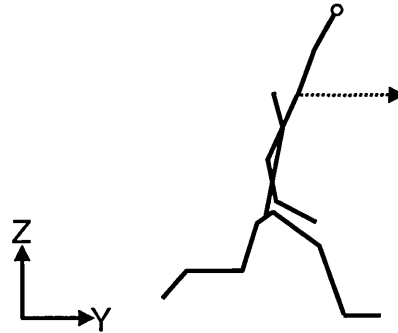

Maximum Right Wrist Speed: The maximum speed of the right wrist joint centre along the y-axis during the period between BFI and BR.



Maximum Pelvis-Upper Torso Separation Angle: The maximum difference between the alignment of the upper torso and pelvis at any moment between BFI and BR.

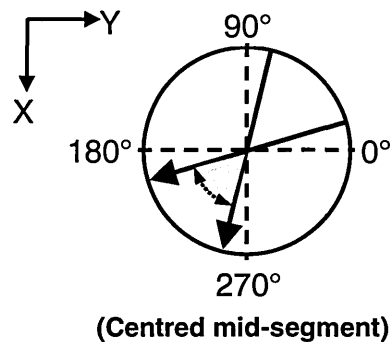

Minimum Upper Torso Alignment: The minimum upper torso alignment angle during the period between BFI and BR.

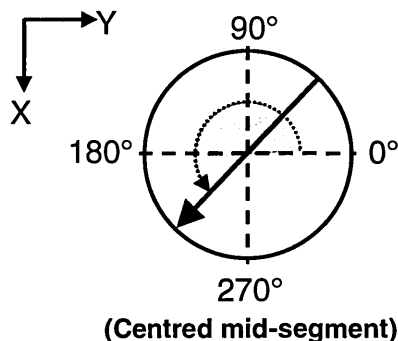

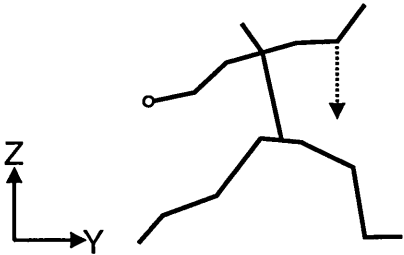
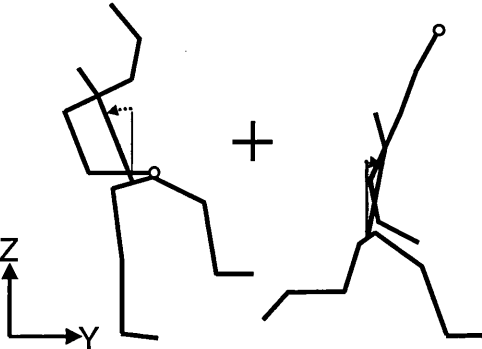
<p>Minimum Pelvis Alignment: The minimum pelvis alignment angle during the period between BFI and BR.</p>	
<p>Maximum Pelvis Angular Velocity: The maximum rate of change of pelvis alignment during the period between BFI and BR.</p>	
<p>Maximum Upper Torso Angular Velocity: The maximum rate of change of upper torso alignment during the period between BFI and BR.</p>	
<p>Maximum Trunk Angular Velocity: The maximum rate of change of the trunk flexion-extension angle during the period between BFI and BR.</p>	
<p>Maximum Vertical Velocity of the Non-Bowling Elbow: The maximum velocity of the elbow joint centre of the non-bowling arm in the z-axis during the period between BFI and BR.</p>	
<p>Trunk Flexion-Extension Range of Motion (ROM): The difference between the minimum trunk flexion-extension angle and the maximum trunk flexion-extension angle during the period between BFI and BR.</p>	
<p>Pelvis Range of Motion (ROM): The maximum pelvis alignment angle minus the minimum pelvis alignment angle during the period between BFI and BR.</p>	

<p>Upper Torso Range of Motion (ROM): The maximum upper torso alignment angle minus the minimum upper torso alignment angle during the period between BFI and BR.</p>	
--	--

Appendix E

Time-Discrete Performance Parameter Data Sets

Measurement Error – Trial 2 from Participant 7

BACK FOOT IMPACT	Re-digitisation	Upper Torso Alignment (°)	Pelvis Alignment (°)	Back Foot Alignment (°)	COM Horizontal Velocity (m.s ⁻¹)	Trunk Flexion-Extension (°)	BACK FOOT IMPACT
	1	249.0	185.0	270.0	3.99	-13.3	
	2	250.0	183.2	273.6	3.99	-13.0	
	3	251.6	186.6	274.8	3.90	-14.0	
	4	247.9	182.5	272.8	4.07	-13.3	
	5	247.5	182.9	274.3	4.09	-13.6	
	6	247.3	185.1	274.2	4.02	-13.8	
	7	248.5	185.1	271.6	4.01	-13.6	
	8	250.1	182.3	272.1	4.01	-12.6	
	9	247.8	182.7	272.3	3.95	-12.7	
	10	250.1	185.4	273.5	3.91	-13.2	
	11	252.1	184.0	273.9	3.94	-13.5	
	12	251.5	184.4	275.0	3.97	-13.8	
	Mean	249.45	184.10	273.18	3.99	-13.37	
SD	1.696	1.377	1.469	0.058	0.438		

E

FRONT FOOT IMPACT	Re-digitisation	Upper Torso Alignment (°)	Pelvis Alignment (°)	Front Knee Angle (°)	COM Horizontal Velocity (m.s ⁻¹)	Trunk Flexion-Extension (°)	Trunk Lateral Flexion (°)	Non-Bowling Arm to Horizontal (°)	Bowling Arm to Horizontal (°)	FRONT FOOT IMPACT
	1	186.2	199.9	175.0	3.06	12.3	68.0	-58.5	-0.6	
	2	187.3	197.9	175.2	3.14	11.2	67.6	-55.3	-0.4	
	3	189.8	203.4	173.1	3.09	10.9	67.2	-54.9	-0.1	
	4	189.1	196.4	178.1	3.30	9.7	65.7	-57.0	-0.1	
	5	188.0	195.6	177.8	3.21	8.9	66.1	-55.6	-0.6	
	6	188.2	197.8	177.9	3.22	9.4	65.7	-56.2	-0.4	
	7	184.9	199.0	174.6	2.96	12.0	68.4	-56.8	-0.8	
	8	187.0	198.5	175.4	3.10	11.8	67.0	-55.2	-2.1	
	9	188.4	198.9	175.7	3.21	11.6	67.2	-57.0	-0.1	
	10	187.7	200.2	175.3	3.15	11.6	67.2	-55.9	-0.2	
	11	190.6	202.6	173.5	3.14	11.0	67.1	-55.8	-0.2	
	12	189.3	201.5	173.1	3.05	10.5	67.6	-54.4	-0.5	
	Mean	188.04	199.31	175.39	3.14	10.91	67.07	-56.05	-0.51	
SD	1.581	2.353	1.769	0.092	1.083	0.850	1.129	0.552		

Measurement Error – Trial 2 from Participant 7 (Cont.)

BALL RELEASE	Re-digitisation	Height of Ball Release (m)	Trunk Flexion-Extension (°)	Front Knee Angle (°)	COM Horizontal Velocity (m.s ⁻¹)	Trunk Lateral Flexion (°)	BALL RELEASE
	1	1.704	41.7	183.6	1.50	51.3	
	2	1.695	42.0	181.5	1.45	51.5	
	3	1.692	42.2	187.0	1.57	48.8	
	4	1.694	41.9	187.0	1.31	49.6	
	5	1.697	41.7	185.3	1.44	49.6	
	6	1.697	42.0	187.6	1.48	49.5	
	7	1.696	41.7	182.0	1.64	51.4	
	8	1.691	41.1	183.6	1.56	52.5	
	9	1.695	41.9	186.5	1.40	49.1	
	10	1.695	42.2	183.6	1.49	51.4	
	11	1.693	42.0	186.5	1.40	49.2	
	12	1.693	41.9	185.0	1.52	49.1	
	Mean	1.70	41.86	184.93	1.48	50.25	
SD	0.003	0.294	2.054	0.089	1.266		

E

OTHER	Re-digitisation	Delivery Stride Length (m)	Delivery Stride Alignment (°)	Maximum Right Hip Speed (m.s ⁻¹)	Maximum Right Shoulder Speed (m.s ⁻¹)	Maximum Right Wrist Speed (m.s ⁻¹)	Maximum Pelvis-Upper Torso Separation Angle (°)	Minimum Upper Torso Alignment (°)	OTHER
	1	1.283	173.9	4.28	6.63	17.88	29.8	183.3	
	2	1.273	174.1	4.35	6.58	17.88	19.8	182.4	
	3	1.279	174.1	4.28	6.65	17.88	17.6	183.0	
	4	1.287	173.6	4.38	6.65	17.93	11.6	183.8	
	5	1.292	173.5	4.43	6.60	17.90	12.0	182.8	
	6	1.294	173.6	4.33	6.65	17.95	12.8	183.2	
	7	1.274	173.8	4.30	6.58	17.85	30.2	182.1	
	8	1.277	174.3	4.20	6.53	17.98	19.5	181.3	
	9	1.280	174.3	4.33	6.63	17.93	19.3	183.5	
	10	1.275	174.2	4.20	6.63	17.95	19.7	182.8	
	11	1.280	174.1	4.33	6.63	17.85	12.0	183.7	
	12	1.278	173.9	4.38	6.58	17.83	17.2	182.5	
	Mean	1.28	173.95	4.32	6.61	17.90	18.46	182.87	
SD	0.007	0.278	0.069	0.038	0.047	6.299	0.719		

Measurement Error – Trial 2 from Participant 7 (Cont.)

OTHER CONT.	Re-digitisation	Minimum Pelvis Alignment (°)	Maximum Pelvis Angular Velocity (rad.s ⁻¹)	Maximum Upper Torso Angular Velocity (rad.s ⁻¹)	Maximum Trunk Angular Velocity (rad.s ⁻¹)	Maximum Vertical Velocity of Non-Bowling Elbow (m.s ⁻¹)	Trunk Flexion-Extension ROM (°)	Pelvis ROM (°)	Upper Torso ROM (°)	OTHER CONT.
	1	174.9	12.72	26.55	5.43	-5.68	51.3	86.6	130.3	
	2	172.0	12.36	25.80	5.62	-5.63	52.7	92.5	128.2	
	3	172.6	10.71	24.86	5.55	-5.70	52.3	86.1	129.5	
	4	174.4	12.33	25.51	5.87	-5.73	52.9	87.2	129.6	
	5	172.2	12.67	25.21	5.92	-5.75	54.0	92.1	128.3	
	6	175.1	11.37	25.41	5.84	-5.73	53.6	84.6	129.1	
	7	172.6	13.12	26.32	5.64	-5.67	52.6	91.2	129.0	
	8	172.3	12.32	25.88	5.04	-5.53	51.6	92.2	130.7	
	9	174.0	11.96	26.08	5.45	-5.65	51.7	87.7	129.8	
	10	175.0	11.11	25.88	5.57	-5.68	52.3	80.0	129.5	
	11	172.0	11.25	24.92	5.55	-5.68	51.4	88.7	129.7	
	12	169.8	11.75	24.65	5.62	-5.68	52.5	93.4	128.8	
	Mean	173.08	11.97	25.59	5.59	-5.68	52.41	88.53	129.38	
SD	1.613	0.741	0.600	0.235	0.057	0.839	3.967	0.742		

Intra-Individual Variability – Participant 1

BACK FOOT IMPACT	Trial	Upper Torso Alignment (°)	Pelvis Alignment (°)	Back Foot Alignment (°)	COM Horizontal Velocity (m.s ⁻¹)	Trunk Flexion-Extension (°)	BACK FOOT IMPACT
	1	212.6	179.4	313.7	5.26	-6.7	
	2	210.9	180.8	321.1	5.25	-4.0	
	3	205.9	179.2	316.8	5.48	-2.1	
	4	217.3	183.1	317.6	5.34	-3.2	
	5	208.6	178.6	304.3	5.62	-5.6	
	6	209.0	180.7	315.1	5.58	-1.5	
	7	210.7	179.7	316.7	5.55	-5.9	
	8	209.7	182.3	315.5	5.70	-4.7	
	9	214.7	180.6	320.6	5.45	-7.2	
	10	205.6	180.9	317.9	5.54	-2.4	
	11	210.6	183.5	326.8	5.43	1.7	
	12	205.4	177.6	307.1	5.70	-6.4	
	Mean	210.08	180.53	316.10	5.49	-4.00	
SD	3.619	1.780	5.981	0.153	2.620		

E

FRONT FOOT IMPACT	Trial	Upper Torso Alignment (°)	Pelvis Alignment (°)	Front Knee Angle (°)	COM Horizontal Velocity (m.s ⁻¹)	Trunk Flexion-Extension (°)	Trunk Lateral Flexion (°)	Non-Bowling Arm to Horizontal (°)	Bowling Arm to Horizontal (°)	FRONT FOOT IMPACT
	1	190.3	211.4	169.9	3.93	9.7	72.5	-53.1	-12.9	
	2	196.5	227.8	171.5	3.83	10.9	69.1	-58.8	-5.1	
	3	193.0	217.3	169.4	4.07	9.2	72.0	-54.1	-13.5	
	4	191.4	227.5	165.9	4.10	10.9	74.0	-52.1	-12.4	
	5	190.8	214.1	168.1	4.27	7.1	74.8	-55.1	-15.8	
	6	193.7	225.9	165.2	4.03	12.1	72.2	-54.3	-10.3	
	7	196.4	229.0	168.2	3.86	11.3	71.5	-59.9	-3.6	
	8	194.4	223.5	167.5	3.97	10.5	72.2	-51.7	-9.6	
	9	189.9	226.1	172.4	4.02	7.5	71.6	-48.4	-11.5	
	10	198.6	225.9	164.4	3.71	11.0	69.8	-65.6	-1.2	
	11	195.7	223.1	168.7	4.11	10.0	73.3	-54.2	-10.7	
	12	192.1	223.7	163.4	4.07	9.0	70.7	-56.5	-13.4	
	Mean	193.57	222.94	167.86	4.00	9.93	71.98	-55.32	-10.00	
SD	2.799	5.662	2.899	0.149	1.517	1.629	4.475	4.442		

Intra-Individual Variability – Participant 1 (Cont.)

BALL RELEASE	Trial	Height of Ball Release (m)	Trunk Flexion-Extension (°)	Front Knee Angle (°)	COM Horizontal Velocity (m.s ⁻¹)	Trunk Lateral Flexion (°)	BALL RELEASE
	1	1.889	37.4	163.3	3.03	52.0	
	2	1.894	35.5	156.4	3.16	48.6	
	3	1.837	35.9	161.3	3.08	49.6	
	4	1.797	36.8	145.9	3.35	50.7	
	5	1.896	34.0	160.2	2.82	52.9	
	6	1.765	41.3	139.6	3.38	48.5	
	7	1.868	36.8	157.0	3.04	51.2	
	8	1.879	35.1	147.3	2.97	51.2	
	9	1.898	36.2	166.5	2.91	50.1	
	10	1.833	33.9	164.5	3.44	52.2	
	11	1.849	42.1	161.4	2.68	51.9	
	12	1.838	38.7	156.3	3.00	47.3	
	Mean	1.85	36.98	156.64	3.07	50.52	
SD	0.042	2.593	8.277	0.229	1.724		

E

OTHER	Trial	Delivery Stride Length (m)	Delivery Stride Alignment (°)	Maximum Right Hip Speed (m.s ⁻¹)	Maximum Right Shoulder Speed (m.s ⁻¹)	Maximum Right Wrist Speed (m.s ⁻¹)	Maximum Pelvis-Upper Torso Separation Angle (°)	Minimum Upper Torso Alignment (°)	OTHER
	1	1.320	170.4	5.45	7.87	19.99	26.3	181.9	
	2	1.350	171.0	5.95	7.90	19.87	32.8	183.1	
	3	1.334	170.2	5.98	8.00	19.87	28.6	181.6	
	4	1.365	170.9	6.00	7.90	19.22	42.7	182.7	
	5	1.250	170.1	5.70	7.92	19.93	28.4	179.7	
	6	1.435	172.9	6.10	8.15	20.02	35.0	182.6	
	7	1.324	170.7	5.78	8.07	20.54	33.3	182.6	
	8	1.352	168.3	5.73	7.83	20.12	34.0	180.0	
	9	1.366	171.7	5.98	7.97	20.29	43.6	182.0	
	10	1.332	170.3	5.93	8.00	20.05	29.6	180.9	
	11	1.407	173.1	6.55	8.22	20.27	27.8	181.3	
	12	1.323	169.4	5.85	7.98	20.32	38.1	178.8	
	Mean	1.347	170.750	5.917	7.984	20.041	33.350	181.433	
SD	0.046	1.349	0.265	0.115	0.330	5.722	1.347		

Intra-Individual Variability – Participant 1 (Cont.)

OTHER CONT.	Trial	Minimum Pelvis Alignment (°)	Maximum Pelvis Angular Velocity (rad.s ⁻¹)	Maximum Upper Torso Angular Velocity (rad.s ⁻¹)	Maximum Trunk Angular Velocity (rad.s ⁻¹)	Maximum Vertical Velocity of Non-Bowling Elbow (m.s ⁻¹)	Trunk Flexion-Extension ROM (°)	Pelvis ROM (°)	Upper Torso ROM (°)
	1	179.4	9.96	23.05	5.57	-6.82	44.1	81.3	123.0
	2	179.7	10.67	24.08	5.04	-6.90	39.5	88.4	128.8
	3	178.3	11.35	22.78	5.12	-6.90	38.2	90.1	126.7
	4	182.8	10.84	23.25	5.04	-6.87	40.0	86.2	127.5
	5	178.5	11.52	21.41	4.90	-6.45	40.3	95.4	121.8
	6	180.6	9.93	22.01	5.60	-6.93	42.8	87.8	123.8
	7	178.8	10.24	23.51	5.09	-6.82	42.6	90.0	127.3
	8	182.3	11.91	24.45	4.81	-6.90	39.8	89.3	133.7
	9	180.0	11.42	24.32	5.58	-6.80	43.5	96.0	126.1
	10	180.9	11.4	21.48	5.05	-6.65	38.5	83.4	124.5
	11	180.3	9.57	21.73	6.02	-6.73	40.8	90.9	123.8
	12	177.6	11.92	24.29	5.40	-6.70	45.1	97.9	133.4
Mean	179.93	10.89	23.03	5.27	-6.79	41.27	89.73	126.70	
SD	1.570	0.812	1.147	0.361	0.139	2.275	4.946	3.802	

OTHER CONT.

Intra-Individual Variability – Participant 2

BACK FOOT IMPACT	Trial	Upper Torso Alignment (°)	Pelvis Alignment (°)	Back Foot Alignment (°)	COM Horizontal Velocity (m.s ⁻¹)	Trunk Flexion-Extension (°)	BACK FOOT IMPACT
	1	218.3	197.6	349.0	5.37	-3.2	
	2	231.5	187.1	338.0	4.89	-0.5	
	3	224.0	187.6	339.6	5.08	-1.0	
	4	233.5	190.6	344.0	5.12	-1.0	
	5	223.9	190.6	332.2	5.11	-1.9	
	6	235.8	191.4	339.2	4.90	-3.1	
	7	233.6	193.0	343.4	5.05	-0.9	
	8	230.8	192.8	342.6	5.08	0.4	
	9	225.7	198.5	341.2	5.02	0.5	
	10	224.7	187.2	328.2	5.30	-0.5	
	11	231.0	191.1	334.5	5.32	1.0	
	12	228.5	188.6	326.4	5.29	-4.2	
	Mean	228.44	191.34	338.19	5.13	-1.20	
SD	5.157	3.731	6.726	0.160	1.611		

E

FRONT FOOT IMPACT	Trial	Upper Torso Alignment (°)	Pelvis Alignment (°)	Front Knee Angle (°)	COM Horizontal Velocity (m.s ⁻¹)	Trunk Flexion-Extension (°)	Trunk Lateral Flexion (°)	Non-Bowling Arm to Horizontal (°)	Bowling Arm to Horizontal (°)	FRONT FOOT IMPACT
	1	223.8	247.3	152.6	4.94	7.3	69.5	-72.6	4.6	
	2	230.9	248.2	158.3	4.68	5.7	67.0	-81.3	12.1	
	3	224.7	247.8	156.0	4.67	10.8	68.4	-87.3	6.4	
	4	226.9	253.8	161.8	4.80	6.3	66.3	-70.1	7.2	
	5	226.6	244.7	162.0	4.63	6.3	67.6	-78.8	17.1	
	6	232.1	246.8	161.6	4.50	9.0	68.1	-82.8	13.2	
	7	228.8	251.6	158.3	4.68	9.5	67.4	-77.7	9.5	
	8	235.4	252.5	158.8	4.49	8.6	64.0	-84.8	17.7	
	9	226.7	247.1	155.4	4.51	9.2	67.6	-75.7	7.1	
	10	226.8	253.1	157.6	4.55	10.2	65.0	-78.1	12.9	
	11	241.3	256.3	157.5	4.48	4.7	66.2	-83.4	23.6	
	12	227.1	245.3	157.5	4.70	8.5	68.7	-75.5	5.9	
Mean	229.258	249.542	158.117	4.636	8.008	67.150	-79.008	11.442		
SD	4.992	3.744	2.774	0.140	1.917	1.568	5.112	5.786		

Intra-Individual Variability – Participant 2 (Cont.)

BALL RELEASE	Trial	Height of Ball Release (m)	Trunk Flexion-Extension (°)	Front Knee Angle (°)	COM Horizontal Velocity (m.s ⁻¹)	Trunk Lateral Flexion (°)	BALL RELEASE
	1	1.885	28.2	123.0	2.61	62.9	
	2	1.953	22.9	133.9	2.89	61.7	
	3	1.928	27.3	129.4	2.98	62.0	
	4	2.007	22.5	136.7	3.01	60.1	
	5	1.956	24.1	138.7	3.22	61.3	
	6	1.968	26.8	138.8	2.86	63.9	
	7	1.918	26.4	133.7	2.96	60.2	
	8	1.907	28.3	136.1	2.76	59.2	
	9	1.882	30.9	134.9	2.49	58.2	
	10	1.907	28.8	136.8	2.86	55.7	
	11	1.928	20.7	134.3	2.98	62.1	
	12	1.924	28.0	131.5	2.77	60.7	
	Mean	1.930	26.24	133.98	2.866	60.67	
SD	0.036	3.035	4.412	0.193	2.219		

E

OTHER	Trial	Delivery Stride Length (m)	Delivery Stride Alignment (°)	Maximum Right Hip Speed (m.s ⁻¹)	Maximum Right Shoulder Speed (m.s ⁻¹)	Maximum Right Wrist Speed (m.s ⁻¹)	Maximum Pelvis-Upper Torso Separation Angle (°)	Minimum Upper Torso Alignment (°)	OTHER
	1	1.656	171.8	6.05	8.20	18.55	28.4	199.7	
	2	1.511	171.5	5.88	8.02	18.68	24.5	200.6	
	3	1.541	172.4	6.00	8.20	18.97	25.8	196.2	
	4	1.464	173.9	6.05	7.98	18.69	31.4	204.8	
	5	1.514	171.2	5.80	8.00	18.70	19.8	199.7	
	6	1.531	172.2	5.80	8.12	18.82	25.4	202.5	
	7	1.583	172.7	5.95	8.02	19.02	27.1	199.0	
	8	1.500	171.8	5.95	8.08	19.01	25.2	200.4	
	9	1.591	171.1	6.50	8.33	19.42	26.4	193.5	
	10	1.567	171.2	6.25	8.25	19.87	32.9	193.6	
	11	1.543	170.8	6.10	8.08	19.05	26.0	202.0	
	12	1.567	171.8	6.25	8.33	19.20	22.1	198.4	
	Mean	1.547	171.87	6.048	8.134	18.998	26.25	199.20	
SD	0.050	0.852	0.205	0.125	0.369	3.569	3.405		

Intra-Individual Variability – Participant 2 (Cont.)

OTHER CONT.	Trial	Minimum Pelvis Alignment (°)	Maximum Pelvis Angular Velocity (rad.s⁻¹)	Maximum Upper Torso Angular Velocity (rad.s⁻¹)	Maximum Trunk Angular Velocity (rad.s⁻¹)	Maximum Vertical Velocity of Non-Bowling Elbow (m.s⁻¹)	Trunk Flexion-Extension ROM (°)	Pelvis ROM (°)	Upper Torso ROM (°)	OTHER CONT.
	1	191.1	7.01	17.78	4.15	-6.70	31.4	77.0	110.7	
	2	186.9	8.66	17.61	3.54	-6.45	23.4	77.8	112.6	
	3	187.5	9.69	18.07	3.15	-6.22	28.3	75.0	115.8	
	4	190.5	8.65	19.73	3.61	-6.65	23.5	78.8	117.6	
	5	190.6	9.13	18.19	3.48	-6.50	25.9	76.6	117.5	
	6	191.3	7.99	17.97	3.74	-6.60	29.9	74.0	110.0	
	7	190.5	8.92	18.81	3.38	-6.57	27.3	75.7	119.6	
	8	192.1	10.30	17.53	4.19	-6.70	27.8	76.4	112.7	
	9	196.5	9.38	20.00	4.30	-6.93	30.4	70.7	128.9	
	10	186.8	9.89	20.80	4.04	-6.70	39.2	76.4	127.6	
	11	191.1	13.12	17.15	3.47	-6.53	20.4	75.5	112.6	
	12	188.6	12.38	18.83	3.78	-6.43	30.2	78.0	121.5	
Mean	190.29	9.593	18.539	3.736	-6.582	28.14	75.99	117.26		
SD	2.674	1.719	1.123	0.363	0.178	4.816	2.136	6.239		

Intra-Individual Variability – Participant 3

BACK FOOT IMPACT	Trial	Upper Torso Alignment (°)	Pelvis Alignment (°)	Back Foot Alignment (°)	COM Horizontal Velocity (m.s ⁻¹)	Trunk Flexion-Extension (°)	BACK FOOT IMPACT
	1	223.9	197.1	341.8	5.69	-13.2	
	2	217.2	195.7	334.6	5.22	-15.0	
	3	228.0	200.5	344.2	5.73	-12.2	
	4	223.6	217.1	349.9	5.83	-12.6	
	5	217.4	197.6	340.1	5.71	-13.4	
	6	223.6	206.5	343.3	5.59	-13.3	
	7	217.3	200.0	338.6	5.61	-13.2	
	8	225.6	197.9	339.5	5.60	-16.2	
	9	215.7	200.2	337.9	5.47	-14.5	
	10	220.0	201.9	337.3	5.78	-12.7	
	11	218.4	202.8	342.0	5.86	-10.6	
	12	222.3	202.4	338.6	5.58	-17.0	
	Mean	221.08	201.64	340.65	5.639	-13.66	
SD	3.939	5.696	3.974	0.174	1.765		

E

FRONT FOOT IMPACT	Trial	Upper Torso Alignment (°)	Pelvis Alignment (°)	Front Knee Angle (°)	COM Horizontal Velocity (m.s ⁻¹)	Trunk Flexion-Extension (°)	Trunk Lateral Flexion (°)	Non-Bowling Arm to Horizontal (°)	Bowling Arm to Horizontal (°)	FRONT FOOT IMPACT
	1	209.9	219.5	150.5	4.51	-3.0	75.1	-75.6	2.60	
	2	215.8	229.1	158.3	4.27	0.2	70.6	-88.9	14.8	
	3	216.4	237.7	158.8	4.57	2.3	70.1	-78.8	9.1	
	4	227.0	236.3	159.2	4.19	1.3	63.2	-90.3	17.2	
	5	221.6	241.7	160.9	4.28	0.3	65.8	-96.6	16.8	
	6	212.6	225.9	152.5	4.65	3.2	73.1	-78.5	3.2	
	7	231.6	246.2	157.9	4.05	3.5	64.6	-98.7	26.1	
	8	214.2	225.1	157.7	4.59	-0.3	72.8	-86.9	5.0	
	9	218.4	234.1	159.6	4.48	-1.3	70.1	-86.6	8.8	
	10	217.8	235.8	159.3	4.71	1.2	68.5	-89.3	-3.9	
	11	208.9	221.0	154.8	5.03	-2.3	73.1	-81.9	9.4	
	12	213.0	231.6	159.9	4.59	-0.8	73.1	-78.7	8.4	
	Mean	217.27	232.00	157.45	4.493	0.36	70.01	-85.90	9.79	
SD	6.722	8.181	3.186	0.264	2.050	3.794	7.378	8.001		

Intra-Individual Variability – Participant 3 (Cont.)

BALL RELEASE	Trial	Height of Ball Release (m)	Trunk Flexion-Extension (°)	Front Knee Angle (°)	COM Horizontal Velocity (m.s ⁻¹)	Trunk Lateral Flexion (°)	BALL RELEASE
	1	1.818	35.2	158.7	2.69	46.3	
	2	1.758	34.1	184.2	2.32	45.8	
	3	1.770	35.8	183.5	2.66	45.1	
	4	1.783	37.0	180.7	2.47	44.0	
	5	1.784	31.6	187.2	2.75	44.0	
	6	1.790	34.9	155.8	2.56	49.1	
	7	1.832	32.7	183.5	2.61	46.8	
	8	1.799	35.7	184.7	2.72	45.9	
	9	1.734	32.3	186.8	2.66	45.2	
	10	1.747	37.7	182.7	2.77	44.3	
	11	1.766	34.1	186.3	2.77	42.3	
	12	1.802	31.1	181.5	2.55	47.9	
	Mean	1.782	34.35	179.63	2.628	45.56	
SD	0.029	2.097	10.659	0.135	1.851		

E

OTHER	Trial	Delivery Stride Length (m)	Delivery Stride Alignment (°)	Maximum Right Hip Speed (m.s ⁻¹)	Maximum Right Shoulder Speed (m.s ⁻¹)	Maximum Right Wrist Speed (m.s ⁻¹)	Maximum Pelvis-Upper Torso Separation Angle (°)	Minimum Upper Torso Alignment (°)	OTHER
	1	1.476	179.3	5.75	8.65	20.67	11.9	190.7	
	2	1.484	179.0	5.68	8.73	20.52	13.5	190.2	
	3	1.574	179.2	6.35	9.05	21.05	21.8	193.1	
	4	1.508	179.4	6.28	8.73	20.57	9.8	191.5	
	5	1.626	179.2	6.28	8.83	20.85	20.2	186.1	
	6	1.614	179.5	6.33	8.98	21.22	13.3	191.2	
	7	1.589	179.5	6.22	9.05	20.75	15.8	191.9	
	8	1.520	179.3	6.00	8.90	20.60	12.5	193.1	
	9	1.600	179.1	6.08	8.83	20.77	15.7	187.8	
	10	1.582	179.1	6.33	9.18	20.92	18.3	193.6	
	11	1.506	177.3	6.28	8.85	20.35	15.5	191.8	
	12	1.562	179.6	5.93	9.05	20.87	18.8	191.6	
	Mean	1.553	179.13	6.126	8.903	20.762	15.59	191.05	
SD	0.052	0.603	0.236	0.161	0.241	3.616	2.187		

Intra-Individual Variability – Participant 3 (Cont.)

OTHER CONT.	Trial	Minimum Pelvis Alignment (°)	Maximum Pelvis Angular Velocity (rad.s ⁻¹)	Maximum Upper Torso Angular Velocity (rad.s ⁻¹)	Maximum Trunk Angular Velocity (rad.s ⁻¹)	Maximum Vertical Velocity of Non-Bowling Elbow (m.s ⁻¹)	Trunk Flexion-Extension ROM (°)	Pelvis ROM (°)	Upper Torso ROM (°)
	1	189.6	10.76	23.69	5.64	-5.95	48.4	84.6	141.3
	2	185.5	10.30	23.23	6.10	-5.85	49.1	94.5	145.2
	3	190.3	10.68	23.91	6.49	-6.55	48.0	87.8	143.2
	4	192.5	9.32	22.83	6.90	-6.90	49.6	86.4	148.7
	5	190.4	11.60	22.25	6.34	-5.98	45.0	91.9	138.5
	6	187.7	10.58	22.52	5.81	-6.28	48.2	86.7	138.4
	7	189.4	10.37	22.65	6.42	-5.95	45.9	89.3	143.1
	8	187.3	11.10	23.20	6.48	-5.90	51.9	92.8	144.2
	9	185.4	10.33	22.84	5.99	-6.20	46.8	97.1	152.5
	10	191.4	9.01	23.24	6.55	-6.20	50.4	90.5	146.0
	11	192.6	11.10	24.07	6.05	-5.78	44.7	91.3	150.5
	12	187.8	10.02	23.89	6.13	-6.20	48.1	92.8	143.7
Mean	189.16	10.431	23.193	6.242	-6.145	48.01	90.48	144.61	
SD	2.451	0.733	0.596	0.353	0.323	2.147	3.662	4.349	

OTHER CONT.

Intra-Individual Variability – Participant 4

BACK FOOT IMPACT	Trial	Upper Torso Alignment (°)	Pelvis Alignment (°)	Back Foot Alignment (°)	COM Horizontal Velocity (m.s ⁻¹)	Trunk Flexion-Extension (°)	BACK FOOT IMPACT
	1	244.5	191.5	346.8	5.36	-6.9	
	2	243.4	209.1	349.8	5.41	-2.3	
	3	235.2	198.4	345.1	5.56	-5.0	
	4	232.7	195.3	340.1	5.36	-7.2	
	5	235.4	185.4	346.1	5.37	-8.2	
	6	235.4	186.4	345.7	5.31	-8.6	
	7	230.6	189.7	347.2	5.64	-6.2	
	8	238.6	199.9	337.3	5.49	-5.8	
	9	238.2	192.4	344.5	5.33	-5.6	
	10	237.2	206.5	342.5	5.71	-2.8	
	11	243.3	189.6	341.4	5.50	-4.9	
	12	234.6	189.8	341.0	5.19	-5.0	
	Mean	237.43	194.50	343.958	5.436	-5.708	
SD	4.394	7.587	3.549	0.149	1.912		

E

FRONT FOOT IMPACT	Trial	Upper Torso Alignment (°)	Pelvis Alignment (°)	Front Knee Angle (°)	COM Horizontal Velocity (m.s ⁻¹)	Trunk Flexion-Extension (°)	Trunk Lateral Flexion (°)	Non-Bowling Arm to Horizontal (°)	Bowling Arm to Horizontal (°)	FRONT FOOT IMPACT
	1	204.2	234.6	162.3	3.57	6.0	66.4	-70.2	-3.9	
	2	202.1	226.9	161.9	4.18	0.6	70.0	-70.6	-15.7	
	3	196.9	211.9	167.7	4.14	0.9	65.5	-71.6	-8.2	
	4	196.8	223.9	157.5	4.04	1.5	68.7	-61.9	-16.7	
	5	197.3	216.7	160.6	3.98	3.1	68.8	-68.0	-10.4	
	6	196.2	218.9	167.6	4.01	0.5	67.2	-64.1	-9.3	
	7	196.8	219.8	163.4	4.37	-0.5	69.6	-71.8	-12.8	
	8	196.3	221.2	159.5	4.14	2.6	67.9	-61.2	-16.1	
	9	197.1	219.3	158.2	3.78	4.2	73.5	-71.8	-0.2	
	10	198.4	217.1	163.5	4.05	1.9	67.2	-68.9	-16.3	
	11	198.2	221.6	164.0	4.06	0.8	68.1	-62.6	-7.8	
	12	199.5	229.2	161.0	3.92	1.4	68.2	-67.3	-9.8	
	Mean	198.32	221.76	162.27	4.020	1.92	68.43	-67.50	-10.60	
SD	2.487	6.136	3.236	0.203	1.810	2.043	4.040	5.221		

Intra-Individual Variability – Participant 4 (Cont.)

BALL RELEASE	Trial	Height of Ball Release (m)	Trunk Flexion-Extension (°)	Front Knee Angle (°)	COM Horizontal Velocity (m.s ⁻¹)	Trunk Lateral Flexion (°)	BALL RELEASE
	1	1.681	42.4	172.6	1.56	47.3	
	2	1.708	35.2	165.7	1.49	50.9	
	3	1.627	41.8	162.4	1.87	43.2	
	4	1.714	42.0	152.1	1.63	46.3	
	5	1.688	41.2	172.2	1.50	47.1	
	6	1.648	37.6	162.3	1.53	46.6	
	7	1.674	39.1	171.0	1.52	45.2	
	8	1.704	43.4	159.5	1.53	44.8	
	9	1.773	34.1	143.6	1.64	56.8	
	10	1.692	44.3	166.4	1.65	41.8	
	11	1.744	37.2	165.1	1.70	49.5	
	12	1.744	38.5	164.7	1.74	44.2	
	Mean	1.700	39.73	163.13	1.613	46.98	
SD	0.041	3.277	8.394	0.115	3.996		

E

OTHER	Trial	Delivery Stride Length (m)	Delivery Stride Alignment (°)	Maximum Right Hip Speed (m.s ⁻¹)	Maximum Right Shoulder Speed (m.s ⁻¹)	Maximum Right Wrist Speed (m.s ⁻¹)	Maximum Pelvis-Upper Torso Separation Angle (°)	Minimum Upper Torso Alignment (°)	OTHER
	1	1.526	182.0	5.58	7.85	20.29	30.6	190.1	
	2	1.473	181.7	5.48	7.68	19.70	25.9	192.0	
	3	1.528	182.3	5.70	7.85	20.25	18.6	196.4	
	4	1.476	179.6	5.58	7.76	20.25	29.8	185.3	
	5	1.474	180.2	5.40	7.90	20.50	21.6	185.5	
	6	1.500	180.6	5.48	7.75	20.35	26.5	186.2	
	7	1.490	180.7	5.80	8.08	20.40	28.1	187.8	
	8	1.489	180.8	5.58	7.78	19.72	29.3	186.2	
	9	1.496	180.6	5.38	7.33	18.92	23.8	187.7	
	10	1.528	182.8	5.73	7.85	20.02	25.8	188.3	
	11	1.489	180.6	5.63	7.88	20.35	27.1	187.6	
	12	1.409	181.2	5.60	7.68	19.85	32.3	187.8	
	Mean	1.490	181.09	5.578	7.783	20.050	26.62	188.41	
SD	0.033	0.933	0.128	0.179	0.446	3.891	3.154		

Intra-Individual Variability – Participant 4 (Cont.)

OTHER CONT.	Trial	Minimum Pelvis Alignment (°)	Maximum Pelvis Angular Velocity (rad.s⁻¹)	Maximum Upper Torso Angular Velocity (rad.s⁻¹)	Maximum Trunk Angular Velocity (rad.s⁻¹)	Maximum Vertical Velocity of Non-Bowling Elbow (m.s⁻¹)	Trunk Flexion-Extension ROM (°)	Pelvis ROM (°)	Upper Torso ROM (°)	OTHER CONT.
	1	190.7	8.95	20.40	7.12	-6.05	49.8	76.6	115.8	
	2	200.7	8.29	17.90	6.31	-5.73	37.5	62.8	104.6	
	3	190.8	10.77	19.62	7.29	-5.98	46.8	71.3	113.6	
	4	194.9	10.27	18.35	7.19	-6.08	49.2	63.5	109.7	
	5	185.1	10.32	19.68	7.09	-6.00	49.4	77.1	113.0	
	6	186.4	10.30	20.56	6.74	-6.15	46.2	76.9	113.8	
	7	188.2	10.94	20.15	7.35	-5.68	45.3	74.9	113.6	
	8	192.7	9.75	21.01	7.10	-6.05	49.1	74.3	119.9	
	9	190.2	10.29	17.77	5.47	-5.55	39.7	68.6	101.2	
	10	194.4	11.70	20.92	7.97	-5.68	47.1	74.7	114.2	
	11	189.4	10.73	20.71	7.09	-5.78	42.1	79.3	110.4	
	12	189.4	11.47	20.63	7.28	-5.75	43.6	78.5	113.1	
	Mean	191.08	10.315	19.808	7.000	-5.873	45.48	73.21	111.91	
SD	4.193	0.968	1.175	0.617	0.198	4.022	5.552	4.967		

Intra-Individual Variability – Participant 5

BACK FOOT IMPACT	Trial	Upper Torso Alignment (°)	Pelvis Alignment (°)	Back Foot Alignment (°)	COM Horizontal Velocity (m.s ⁻¹)	Trunk Flexion-Extension (°)	BACK FOOT IMPACT
	1	249.0	193.3	315.9	5.18	0.6	
	2	225.3	188.4	305.0	5.51	3.0	
	3	245.6	187.3	317.1	5.16	3.9	
	4	232.8	190.4	314.7	5.41	3.8	
	5	237.0	189.6	312.8	5.27	4.7	
	6	237.7	188.2	313.4	5.50	3.0	
	7	237.3	188.4	311.2	5.61	5.6	
	8	233.7	188.8	310.3	5.45	5.3	
	9	242.5	191.1	318.2	5.45	6.9	
	10	244.9	191.6	314.4	5.53	4.4	
	11	239.2	190.8	318.4	5.24	4.2	
	12	238.5	189.9	313.4	5.43	6.9	
	Mean	238.63	189.82	313.73	5.395	4.36	
SD	6.410	1.714	3.750	0.147	1.754		

E

FRONT FOOT IMPACT	Trial	Upper Torso Alignment (°)	Pelvis Alignment (°)	Front Knee Angle (°)	COM Horizontal Velocity (m.s ⁻¹)	Trunk Flexion-Extension (°)	Trunk Lateral Flexion (°)	Non-Bowling Arm to Horizontal (°)	Bowling Arm to Horizontal (°)	FRONT FOOT IMPACT
	1	203.3	238.5	160.8	4.42	2.0	74.1	-52.5	5.7	
	2	201.4	234.8	163.8	4.14	2.0	72.4	-60.2	8.8	
	3	200.6	237.9	165.9	4.19	9.6	76.1	-57.1	6.7	
	4	197.6	236.0	162.4	4.13	5.5	76.1	-55.5	3.2	
	5	199.8	239.6	166.9	4.27	4.5	74.7	-63.9	10.9	
	6	200.3	238.6	164.2	3.89	5.3	73.2	-60.6	10.0	
	7	200.4	237.1	167.2	4.19	5.1	75.8	-55.0	2.7	
	8	200.5	230.6	165.8	4.17	4.8	75.2	-53.6	3.8	
	9	200.9	240.2	164.4	4.21	6.2	72.9	-53.7	3.9	
	10	197.1	238.3	166.7	4.32	7.1	74.1	-57.1	2.7	
	11	201.4	243.3	165.3	4.10	8.9	73.5	-62.9	5.2	
	12	198.8	235.9	163.7	4.30	5.8	74.1	-59.9	2.1	
	Mean	200.18	237.57	164.76	4.194	5.57	74.35	-57.67	5.48	
SD	1.699	3.136	1.924	0.132	2.289	1.251	3.786	3.013		

Intra-Individual Variability – Participant 5 (Cont.)

BALL RELEASE	Trial	Height of Ball Release (m)	Trunk Flexion-Extension (°)	Front Knee Angle (°)	COM Horizontal Velocity (m.s ⁻¹)	Trunk Lateral Flexion (°)	BALL RELEASE
	1	2.003	20.6	130.9	2.94	58.5	
	2	1.996	20.4	136.6	2.74	54.2	
	3	1.975	27.5	130.9	2.96	58.7	
	4	2.002	22.0	129.1	3.04	57.5	
	5	2.016	22.8	135.4	2.91	56.6	
	6	1.965	26.3	132.9	3.04	55.7	
	7	1.991	24.5	136.7	2.81	56.4	
	8	2.033	22.5	127.3	2.85	59.4	
	9	2.019	23.7	133.8	2.78	55.3	
	10	1.984	27.5	135.8	3.00	57.0	
	11	1.994	28.4	137.2	2.86	56.5	
	12	1.963	26.7	136.6	2.94	55.1	
	Mean	1.995	24.41	133.60	2.906	56.74	
SD	0.021	2.812	3.353	0.099	1.571		

F

OTHER	Trial	Delivery Stride Length (m)	Delivery Stride Alignment (°)	Maximum Right Hip Speed (m.s ⁻¹)	Maximum Right Shoulder Speed (m.s ⁻¹)	Maximum Right Wrist Speed (m.s ⁻¹)	Maximum Pelvis-Upper Torso Separation Angle (°)	Minimum Upper Torso Alignment (°)	OTHER
	1	1.295	173.6	6.20	7.80	20.20	37.1	188.4	
	2	1.165	173.3	6.20	7.78	20.20	35.8	188.0	
	3	1.363	174.4	5.93	7.80	20.25	37.4	189.8	
	4	1.278	173.5	5.95	7.80	20.40	40.2	188.8	
	5	1.287	172.7	6.18	8.08	20.02	39.9	187.5	
	6	1.308	173.2	6.00	7.98	20.35	39.3	187.4	
	7	1.287	172.7	6.08	7.93	20.20	37.4	188.6	
	8	1.266	172.5	5.90	7.83	20.25	31.3	186.3	
	9	1.308	175.1	6.20	7.78	20.07	39.7	188.8	
	10	1.306	173.1	6.10	8.08	20.20	42.4	188.4	
	11	1.315	174.5	5.80	7.80	20.03	42.0	189.1	
	12	1.280	173.4	6.08	7.90	19.97	37.1	188.8	
	Mean	1.288	173.50	6.052	7.880	20.178	38.30	188.33	
SD	0.046	0.795	0.135	0.113	0.132	3.006	0.919		

Intra-Individual Variability – Participant 5 (Cont.)

OTHER CONT.	Trial	Minimum Pelvis Alignment (°)	Maximum Pelvis Angular Velocity (rad.s⁻¹)	Maximum Upper Torso Angular Velocity (rad.s⁻¹)	Maximum Trunk Angular Velocity (rad.s⁻¹)	Maximum Vertical Velocity of Non-Bowling Elbow (m.s⁻¹)	Trunk Flexion-Extension ROM (°)	Pelvis ROM (°)	Upper Torso ROM (°)	OTHER CONT.
	1	193.0	7.25	18.70	3.95	-6.95	24.2	74.9	104.1	
	2	197.9	10.93	21.82	4.39	-6.72	23.5	80.4	111.3	
	3	187.3	7.49	21.97	3.80	-6.82	26.7	78.6	110.2	
	4	190.4	9.72	22.97	3.70	-6.70	24.9	79.4	105.4	
	5	189.5	8.87	21.47	4.02	-6.50	25.2	75.2	108.6	
	6	188.2	9.84	22.90	4.18	-6.75	30.6	78.0	114.9	
	7	188.4	8.62	21.07	4.23	-6.73	26.2	78.2	106.4	
	8	188.8	9.97	21.65	4.05	-6.55	24.4	77.4	110.4	
	9	190.9	8.75	21.48	4.19	-6.90	23.9	75.0	103.4	
	10	191.6	9.78	22.15	4.01	-7.03	29.4	75.0	105.9	
	11	190.7	8.79	21.56	3.29	-6.60	28.3	72.0	109.2	
	12	190.0	8.32	21.11	4.50	-6.33	27.6	78.7	113.2	
Mean	190.56	9.028	21.571	4.026	-6.715	26.24	76.90	108.58		
SD	2.804	1.069	1.088	0.324	0.199	2.310	2.448	3.618		

Intra-Individual Variability – Participant 6

BACK FOOT IMPACT	Trial	Upper Torso Alignment (°)	Pelvis Alignment (°)	Back Foot Alignment (°)	COM Horizontal Velocity (m.s ⁻¹)	Trunk Flexion-Extension (°)	BACK FOOT IMPACT
	1	232.2	188.8	342.1	4.80	-14.1	
	2	241.3	205.3	344.2	4.76	-15.2	
	3	238.0	188.1	340.4	4.96	-14.0	
	4	230.7	189.3	348.5	5.20	-13.3	
	5	229.4	188.9	336.8	5.14	-12.7	
	6	242.6	191.0	344.6	4.99	-11.4	
	7	233.5	189.4	342.1	5.20	-15.6	
	8	239.7	190.6	336.3	5.10	-14.6	
	9	229.0	185.0	343.6	5.20	-12.8	
	10	234.4	183.8	341.7	5.14	-11.8	
	11	238.1	184.8	336.8	5.19	-11.9	
	12	236.2	184.7	333.7	5.32	-12.2	
	Mean	235.43	189.14	340.90	5.083	-13.30	
SD	4.610	5.659	4.264	0.172	1.393		

E

FRONT FOOT IMPACT	Trial	Upper Torso Alignment (°)	Pelvis Alignment (°)	Front Knee Angle (°)	COM Horizontal Velocity (m.s ⁻¹)	Trunk Flexion-Extension (°)	Trunk Lateral Flexion (°)	Non-Bowling Arm to Horizontal (°)	Bowling Arm to Horizontal (°)	FRONT FOOT IMPACT
	1	207.8	233.3	158.3	3.42	14.6	72.3	-97.5	15.5	
	2	203.6	233.5	160.2	3.57	14.2	75.5	-84.2	7.0	
	3	200.2	223.7	158.9	3.85	13.4	74.8	-85.8	4.2	
	4	196.8	226.1	157.2	3.72	10.5	76.5	-81.6	1.6	
	5	202.7	235.2	161.0	3.76	16.1	74.5	-85.8	6.9	
	6	208.8	236.2	158.7	4.13	14.4	72.0	-82.7	7.9	
	7	201.5	231.2	158.8	3.72	11.2	74.7	-89.8	4.7	
	8	195.7	224.8	159.8	3.65	10.8	74.3	-90.8	3.5	
	9	204.3	232.4	158.5	3.73	11.3	74.5	-86.6	9.0	
	10	203.7	229.4	156.1	3.70	11.8	74.1	-87.8	6.1	
	11	199.5	229.0	160.2	3.78	14.9	76.1	-77.8	5.0	
	12	201.0	226.4	162.9	3.88	15.6	73.8	-84.6	9.9	
	Mean	202.13	230.10	159.22	3.743	13.23	74.43	-86.25	6.78	
SD	3.912	4.177	1.776	0.173	2.002	1.328	5.003	3.621		

Intra-Individual Variability – Participant 6 (Cont.)

BALL RELEASE	Trial	Height of Ball Release (m)	Trunk Flexion-Extension (°)	Front Knee Angle (°)	COM Horizontal Velocity (m.s ⁻¹)	Trunk Lateral Flexion (°)	BALL RELEASE
	1	1.696	42.1	178.9	1.61	53.3	
	2	1.731	40.3	181.6	1.56	58.0	
	3	1.678	43.9	181.2	1.74	52.0	
	4	1.658	44.1	181.7	1.54	53.5	
	5	1.669	46.9	181.9	1.80	52.0	
	6	1.705	44.9	182.4	1.68	52.8	
	7	1.707	41.0	183.9	1.81	54.6	
	8	1.696	43.4	183.4	1.90	53.2	
	9	1.647	42.9	185.7	1.77	53.5	
	10	1.676	45.2	182.3	1.80	52.0	
	11	1.697	32.9	184.6	1.95	57.0	
	12	1.684	44.8	184.1	1.69	60.4	
	Mean	1.687	42.70	182.64	1.738	54.36	
SD	0.023	3.594	1.815	0.127	2.694		

E

OTHER	Trial	Delivery Stride Length (m)	Delivery Stride Alignment (°)	Maximum Right Hip Speed (m.s ⁻¹)	Maximum Right Shoulder Speed (m.s ⁻¹)	Maximum Right Wrist Speed (m.s ⁻¹)	Maximum Pelvis-Upper Torso Separation Angle (°)	Minimum Upper Torso Alignment (°)	OTHER
	1	1.270	172.2	4.80	7.98	20.90	26.5	185.1	
	2	1.403	175.0	5.03	7.95	20.52	30.1	187.0	
	3	1.373	173.8	4.90	8.20	20.82	24.0	182.6	
	4	1.354	175.8	5.10	8.20	21.12	29.9	182.6	
	5	1.328	173.1	5.22	8.43	21.42	33.4	186.6	
	6	1.386	175.2	5.55	8.58	20.90	27.4	189.0	
	7	1.325	172.8	5.00	8.53	21.74	29.8	182.9	
	8	1.292	174.8	5.03	8.40	21.42	30.9	183.6	
	9	1.301	172.7	5.10	8.43	21.47	28.2	183.5	
	10	1.313	174.4	5.25	8.55	21.67	26.0	185.2	
	11	1.379	173.9	5.10	8.40	21.05	30.0	182.7	
	12	1.415	175.4	5.48	8.57	21.66	25.4	184.9	
	Mean	1.345	174.09	5.130	8.352	21.224	28.47	184.64	
SD	0.047	1.190	0.218	0.220	0.393	2.690	2.056		

Intra-Individual Variability – Participant 6 (Cont.)

OTHER CONT.	Trial	Minimum Pelvis Alignment (°)	Maximum Pelvis Angular Velocity (rad.s⁻¹)	Maximum Upper Torso Angular Velocity (rad.s⁻¹)	Maximum Trunk Angular Velocity (rad.s⁻¹)	Maximum Vertical Velocity of Non-Bowling Elbow (m.s⁻¹)	Trunk Flexion-Extension ROM (°)	Pelvis ROM (°)	Upper Torso ROM (°)	OTHER CONT.
	1	187.1	10.59	22.72	6.40	-5.50	56.2	85.6	123.6	
	2	186.5	9.70	21.37	5.82	-6.33	55.5	81.0	113.3	
	3	184.5	8.47	24.74	6.35	-5.80	57.9	83.8	132.9	
	4	187.9	10.69	25.01	6.77	-5.83	57.4	82.0	134.6	
	5	188.6	9.48	24.58	6.72	-6.03	59.6	79.5	125.6	
	6	182.3	11.10	23.49	7.18	-6.67	56.3	88.9	122.3	
	7	187.4	10.27	24.92	6.89	-5.63	56.6	81.7	129.1	
	8	186.0	10.94	25.92	6.86	-5.83	58.0	83.7	129.9	
	9	185.0	10.81	24.15	6.92	-5.58	55.7	90.4	133.2	
	10	182.9	11.68	24.89	7.19	-6.00	57.0	94.7	134.0	
	11	183.8	11.05	23.42	6.31	-6.08	54.5	89.2	122.8	
	12	184.7	11.80	22.30	6.71	-6.55	56.9	84.1	112.6	
Mean	185.56	10.548	23.959	6.677	-5.986	56.80	85.38	126.16		
SD	2.012	0.949	1.324	0.395	0.372	1.340	4.520	7.584		

Intra-Individual Variability – Participant 7

BACK FOOT IMPACT	Trial	Upper Torso Alignment (°)	Pelvis Alignment (°)	Back Foot Alignment (°)	COM Horizontal Velocity (m.s ⁻¹)	Trunk Flexion-Extension (°)	BACK FOOT IMPACT
	1	242.0	177.1	247.1	3.86	-8.2	
	2	241.5	176.3	241.6	3.86	-10.2	
	3	241.4	177.6	244.5	3.79	-9.1	
	4	235.0	172.9	241.1	3.90	-10.9	
	5	239.0	170.7	243.6	4.10	-10.2	
	6	241.4	171.7	244.5	4.19	-12.7	
	7	240.5	173.8	242.3	4.01	-11.2	
	8	248.0	172.7	240.1	4.05	-10.6	
	9	249.6	175.5	246.1	4.15	-12.3	
	10	247.7	168.6	245.1	4.32	-11.0	
	11	241.2	174.6	241.1	4.14	-11.7	
	12	237.6	170.3	236.4	4.24	-13.2	
Mean	242.075	173.483	242.792	4.051	-10.942		
SD	4.342	2.848	2.967	0.169	1.440		

E

FRONT FOOT IMPACT	Trial	Upper Torso Alignment (°)	Pelvis Alignment (°)	Front Knee Angle (°)	COM Horizontal Velocity (m.s ⁻¹)	Trunk Flexion-Extension (°)	Trunk Lateral Flexion (°)	Non-Bowling Arm to Horizontal (°)	Bowling Arm to Horizontal (°)	FRONT FOOT IMPACT
	1	187.2	202.4	175.2	2.93	14.6	65.9	-58.7	7.7	
	2	189.6	203.0	173.0	3.11	10.8	67.4	-54.3	-1.3	
	3	187.2	206.7	172.1	3.00	15.8	65.1	-56.5	7.7	
	4	189.4	202.8	169.8	3.28	9.3	63.9	-50.0	0.3	
	5	190.3	205.9	175.9	3.17	13.7	65.8	-59.6	6.2	
	6	193.2	209.8	172.1	2.98	11.3	63.7	-58.6	6.0	
	7	186.9	203.7	176.1	3.02	12.7	64.8	-57.9	4.2	
	8	184.6	202.6	180.5	3.04	14.0	65.2	-59.9	4.8	
	9	189.3	206.4	173.9	3.18	11.5	63.6	-57.9	2.3	
	10	188.0	208.9	170.1	3.15	12.5	64.4	-63.1	6.7	
	11	185.2	201.0	175.9	3.32	12.8	65.1	-55.7	0.5	
	12	190.9	217.0	174.4	2.91	13.9	62.6	-61.0	7.8	
Mean	188.48	205.85	174.08	3.09	12.74	64.79	-57.77	4.41		
SD	2.45	4.45	2.96	0.13	1.81	1.27	3.39	3.21		

Intra-Individual Variability – Participant 7 (Cont.)

BALL RELEASE	Trial	Height of Ball Release (m)	Trunk Flexion-Extension (°)	Front Knee Angle (°)	COM Horizontal Velocity (m.s ⁻¹)	Trunk Lateral Flexion (°)	BALL RELEASE
	1	1.574	43.9	180.0	1.60	40.4	
	2	1.689	42.2	187.1	1.57	48.8	
	3	1.590	43.2	186.7	1.78	46.2	
	4	1.692	40.4	177.0	1.48	44.7	
	5	1.724	37.4	186.4	1.46	51.2	
	6	1.729	37.4	183.2	1.59	48.4	
	7	1.742	38.5	181.6	1.42	49.1	
	8	1.761	39.9	185.0	1.38	49.7	
	9	1.684	40.0	186.1	1.53	47.6	
	10	1.698	39.0	181.5	1.39	48.2	
	11	1.605	42.3	191.1	1.66	49.1	
	12	1.637	43.2	184.5	1.69	45.8	
Mean	1.68	40.62	184.18	1.55	47.43		
SD	0.06	2.30	3.77	0.13	2.85		

E

OTHER	Trial	Delivery Stride Length (m)	Delivery Stride Alignment (°)	Maximum Right Hip Speed (m.s ⁻¹)	Maximum Right Shoulder Speed (m.s ⁻¹)	Maximum Right Wrist Speed (m.s ⁻¹)	Maximum Pelvis-Upper Torso Separation Angle (°)	Minimum Upper Torso Alignment (°)	OTHER
	1	1.352	172.3	4.50	6.68	18.20	28.2	180.1	
	2	1.326	174.2	4.28	6.65	17.88	17.6	183.1	
	3	1.334	173.2	4.74	6.68	18.52	27.3	178.6	
	4	1.310	174.9	4.50	6.70	18.35	19.5	180.0	
	5	1.314	174.0	4.45	6.75	18.77	23.5	179.9	
	6	1.300	175.7	4.38	6.85	18.80	20.1	179.5	
	7	1.323	173.9	4.42	6.90	18.91	25.6	181.2	
	8	1.327	174.4	4.58	6.95	18.99	28.3	179.3	
	9	1.363	176.4	4.65	7.07	18.96	24.9	180.4	
	10	1.386	176.6	4.50	7.08	19.12	29.6	182.3	
	11	1.355	174.3	4.58	7.10	19.02	24.6	179.1	
	12	1.362	175.9	4.56	7.10	19.29	32.1	180.0	
Mean	1.338	174.65	4.512	6.876	18.734	25.11	180.29		
SD	0.026	1.300	0.123	0.181	0.416	4.366	1.315		

Intra-Individual Variability – Participant 7 (Cont.)

OTHER CONT.	Trial	Minimum Pelvis Alignment (°)	Maximum Pelvis Angular Velocity (rad.s⁻¹)	Maximum Upper Torso Angular Velocity (rad.s⁻¹)	Maximum Trunk Angular Velocity (rad.s⁻¹)	Maximum Vertical Velocity of Non-Bowling Elbow (m.s⁻¹)	Trunk Flexion-Extension ROM (°)	Pelvis ROM (°)	Upper Torso ROM (°)
	1	176.2	13.68	27.25	5.57	-5.82	52.1	88.7	137.6
	2	172.7	10.71	24.86	5.55	-5.70	52.5	86.0	129.3
	3	177.6	12.71	26.62	5.24	-5.98	57.2	86.8	136.2
	4	172.6	12.29	26.36	6.10	-5.75	52.9	89.6	130.2
	5	166.7	12.86	26.10	5.18	-5.87	47.5	92.3	117.9
	6	171.3	12.53	24.66	5.64	-5.75	50.4	91.5	123.8
	7	172.1	12.89	26.35	5.87	-5.88	51.2	88.7	117.9
	8	171.5	13.16	29.24	6.08	-5.93	50.6	85.1	115.1
	9	171.5	12.29	26.51	6.08	-5.85	52.2	90.2	121.5
	10	168.4	11.48	28.72	5.70	-6.20	50.0	88.3	127.7
	11	173.3	12.15	27.29	5.49	-6.10	54.0	85.3	135.8
	12	168.8	12.74	26.40	6.19	-6.00	56.5	89.2	133.0
Mean	171.89	12.458	26.697	5.724	-5.903	52.26	88.48	127.17	
SD	3.070	0.777	1.330	0.341	0.148	2.714	2.318	7.827	

OTHER CONT.

Intra-Individual Variability – Participant 8

BACK FOOT IMPACT	Trial	Upper Torso Alignment (°)	Pelvis Alignment (°)	Back Foot Alignment (°)	COM Horizontal Velocity (m.s ⁻¹)	Trunk Flexion-Extension (°)	BACK FOOT IMPACT
	1	237.3	176.1	282.1	3.53	-16.3	
	2	234.7	181.4	291.3	3.30	-16.1	
	3	238.8	177.8	292.6	3.49	-15.5	
	4	238.9	178.4	290.1	3.43	-17.0	
	5	235.7	179.1	292.2	3.45	-16.0	
	6	238.9	177.8	289.0	3.31	-17.3	
	7	223.8	175.1	287.0	3.26	-15.4	
	8	238.8	177.8	289.1	3.52	-15.0	
	9	233.4	174.3	284.9	3.42	-15.0	
	10	239.7	175.8	286.0	3.42	-17.0	
	11	229.3	174.8	284.7	3.65	-16.9	
	12	238.5	173.9	277.9	3.94	-21.6	
	Mean	235.65	176.86	287.24	3.477	-16.59	
SD	4.814	2.236	4.387	0.182	1.768		

E

FRONT FOOT IMPACT	Trial	Upper Torso Alignment (°)	Pelvis Alignment (°)	Front Knee Angle (°)	COM Horizontal Velocity (m.s ⁻¹)	Trunk Flexion-Extension (°)	Trunk Lateral Flexion (°)	Non-Bowling Arm to Horizontal (°)	Bowling Arm to Horizontal (°)	FRONT FOOT IMPACT
	1	193.9	214.1	155.6	2.33	9.8	72.8	-78.4	-0.1	
	2	195.9	209.9	160.0	2.62	7.5	73.4	-74.2	-2.9	
	3	202.9	222.5	158.5	2.49	8.1	71.3	-76.0	4.8	
	4	203.5	220.2	160.6	2.17	8.6	70.2	-80.8	2.3	
	5	202.8	208.3	159.3	2.42	8.9	72.2	-76.3	3.3	
	6	204.4	220.2	159.8	2.14	9.9	69.2	-84.1	12.5	
	7	201.4	208.1	152.7	2.10	11.4	67.9	-81.8	10.7	
	8	203.1	222.0	156.9	2.36	10.4	70.3	-81.9	5.5	
	9	198.7	211.0	162.1	2.26	8.7	69.1	-77.2	3.8	
	10	199.4	211.6	162.8	2.22	7.9	68.0	-82.1	7.5	
	11	202.4	217.3	161.5	2.28	8.7	68.4	-76.5	3.8	
	12	197.8	218.8	160.3	2.73	4.6	70.8	-72.4	-6.3	
	Mean	200.52	215.33	159.18	2.343	8.71	70.30	-78.48	3.74	
SD	3.343	5.432	2.889	0.193	1.709	1.860	3.625	5.270		

Intra-Individual Variability – Participant 8 (Cont.)

BALL RELEASE	Trial	Height of Ball Release (m)	Trunk Flexion-Extension (°)	Front Knee Angle (°)	COM Horizontal Velocity (m.s ⁻¹)	Trunk Lateral Flexion (°)	BALL RELEASE
	1	1.803	40.2	162.0	1.26	56.7	
	2	1.822	36.1	156.8	1.23	59.3	
	3	1.821	38.6	166.2	1.29	57.9	
	4	1.783	38.7	165.7	1.38	56.7	
	5	1.797	37.2	168.6	1.19	58.2	
	6	1.791	37.9	167.5	1.15	56.2	
	7	1.832	38.6	171.6	1.14	55.7	
	8	1.790	39.3	169.3	1.17	58.6	
	9	1.821	38.8	172.4	1.30	57.4	
	10	1.761	40.0	175.9	1.13	56.6	
	11	1.766	39.6	171.7	1.37	56.9	
	12	1.821	38.5	170.7	1.12	57.9	
	Mean	1.801	38.63	168.20	1.228	57.34	
SD	0.023	1.158	5.112	0.092	1.060		

E

OTHER	Trial	Delivery Stride Length (m)	Delivery Stride Alignment (°)	Maximum Right Hip Speed (m.s ⁻¹)	Maximum Right Shoulder Speed (m.s ⁻¹)	Maximum Right Wrist Speed (m.s ⁻¹)	Maximum Pelvis-Upper Torso Separation Angle (°)	Minimum Upper Torso Alignment (°)	OTHER
	1	1.289	167.6	3.63	6.98	19.05	20.6	185.8	
	2	1.339	169.7	3.60	6.95	18.33	14.8	185.6	
	3	1.357	168.8	3.83	7.00	18.85	20.6	186.7	
	4	1.334	167.8	3.65	6.95	19.37	16.6	185.8	
	5	1.360	167.4	3.50	6.60	18.65	6.4	187.7	
	6	1.357	168.6	3.63	7.00	18.95	16.4	182.9	
	7	1.320	167.8	3.40	6.83	19.00	7.6	184.5	
	8	1.331	165.8	3.85	7.10	19.27	19.0	185.3	
	9	1.324	166.9	3.68	7.03	18.82	12.3	184.0	
	10	1.377	169.1	3.73	7.15	19.60	12.2	182.6	
	11	1.380	168.3	3.87	7.15	19.38	14.8	186.1	
	12	1.324	167.0	3.83	7.20	19.05	21.9	185.5	
	Mean	1.341	167.90	3.683	6.995	19.027	15.27	185.21	
SD	0.026	1.075	0.146	0.162	0.349	4.990	1.485		

Intra-Individual Variability – Participant 8 (Cont.)

OTHER CONT.	Trial	Minimum Pelvis Alignment (°)	Maximum Pelvis Angular Velocity (rad.s⁻¹)	Maximum Upper Torso Angular Velocity (rad.s⁻¹)	Maximum Trunk Angular Velocity (rad.s⁻¹)	Maximum Vertical Velocity of Non-Bowling Elbow (m.s⁻¹)	Trunk Flexion-Extension ROM (°)	Pelvis ROM (°)	Upper Torso ROM (°)	OTHER CONT.
	1	175.4	9.25	22.16	6.00	-7.07	56.5	65.9	112.9	
	2	179.1	9.08	20.23	5.67	-6.98	53.0	69.2	104.1	
	3	176.6	10.38	20.19	6.24	-7.08	54.2	79.1	112.1	
	4	176.0	10.80	20.31	6.15	-7.12	56.3	81.9	116.6	
	5	176.0	10.19	20.61	5.79	-6.82	53.2	77.1	111.0	
	6	176.6	9.68	20.65	6.15	-6.95	55.7	75.1	116.8	
	7	175.1	9.85	22.69	6.06	-7.08	54.0	65.3	113.6	
	8	177.1	9.75	20.78	5.94	-7.47	54.6	79.9	117.8	
	9	174.3	9.73	21.88	6.38	-7.10	54.1	78.1	114.2	
	10	175.5	10.54	22.33	6.29	-6.90	57.2	76.4	124.9	
	11	174.0	10.96	20.86	6.28	-7.27	56.5	82.1	121.3	
	12	177.6	6.22	20.25	6.69	-6.98	60.2	60.2	109.4	
Mean	176.11	9.703	21.078	6.137	-7.068	55.46	74.19	114.56		
SD	1.423	1.241	0.920	0.273	0.172	2.042	7.240	5.482		

Appendix F
ANOVA Minitab Printouts

BACK FOOT IMPACT

UPPER TORSO ALIGNMENT One-way Analysis of Variance

Analysis of Variance

Source	DF	SS	MS	F	P
Factor	7	9667.1	1381.0	61.76	0.000
Error	88	1967.7	22.4		
Total	95	11634.8			

Level	N	Mean	StDev
1	12	210.08	3.62
2	12	228.44	5.16
3	12	221.08	3.94
4	12	237.42	4.39
5	12	238.62	6.41
6	12	235.42	4.61
7	12	242.07	4.34
8	12	235.65	4.81

Pooled StDev = 4.73

Individual 95% CIs For Mean
Based on Pooled StDev

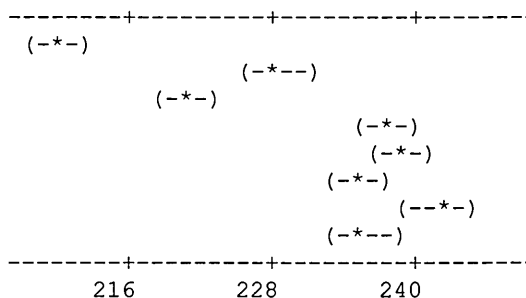

PELVIS ALIGNMENT One-way Analysis of Variance

Analysis of Variance

Source	DF	SS	MS	F	P
Factor	7	7549.8	1078.5	55.61	0.000
Error	88	1706.8	19.4		
Total	95	9256.7			

Level	N	Mean	StDev
1	12	180.53	1.78
2	12	191.34	3.73
3	12	201.64	5.70
4	12	194.50	7.59
5	12	189.82	1.71
6	12	189.14	5.66
7	12	173.48	2.85
8	12	176.86	2.24

Pooled StDev = 4.40

Individual 95% CIs For Mean
Based on Pooled StDev

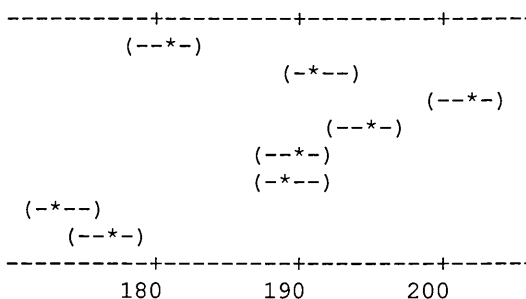

BACK FOOT ALIGNMENT One-way Analysis of Variance

Analysis of Variance

Source	DF	SS	MS	F	P
Factor	7	104291.6	14898.8	702.38	0.000
Error	88	1866.6	21.2		
Total	95	106158.2			

Level	N	Mean	StDev
1	12	316.10	5.98
2	12	338.19	6.73
3	12	340.65	3.97
4	12	343.96	3.55
5	12	313.73	3.75
6	12	340.90	4.26
7	12	242.79	2.97
8	12	287.24	4.39

Pooled StDev = 4.61

Individual 95% CIs For Mean
Based on Pooled StDev

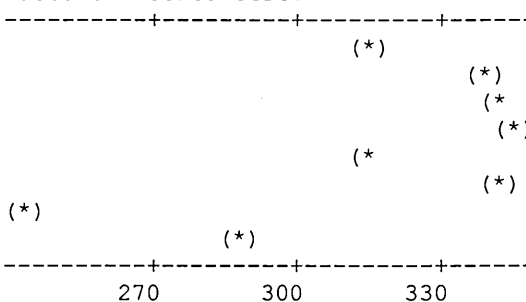

CENTRE OF MASS (COM) HORIZONTAL VELOCITY
One-way Analysis of Variance

Analysis of Variance

Source	DF	SS	MS	F	P
Factor	7	50.7559	7.2508	270.84	0.000
Error	88	2.3559	0.0268		
Total	95	53.1118			

Individual 95% CIs For Mean
Based on Pooled StDev

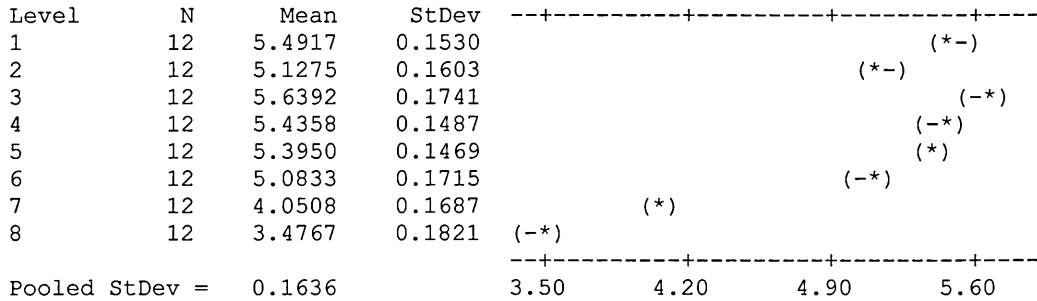

TRUNK FLEXION-EXTENSION
One-way Analysis of Variance

Analysis of Variance

Source	DF	SS	MS	F	P
Factor	7	4340.44	620.06	187.58	0.000
Error	88	290.89	3.31		
Total	95	4631.32			

Individual 95% CIs For Mean
Based on Pooled StDev

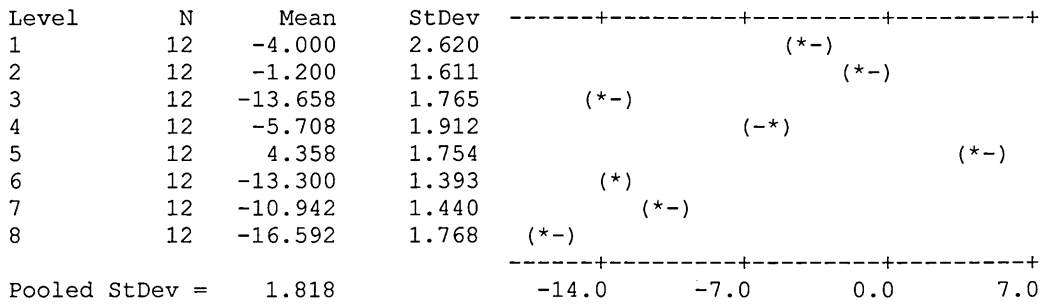

FRONT FOOT IMPACT

UPPER TORSO ALIGNMENT
One-way Analysis of Variance

Analysis of Variance

Source	DF	SS	MS	F	P
Factor	7	14706.1	2100.9	140.65	0.000
Error	88	1314.5	14.9		
Total	95	16020.6			

Individual 95% CIs For Mean
Based on Pooled StDev

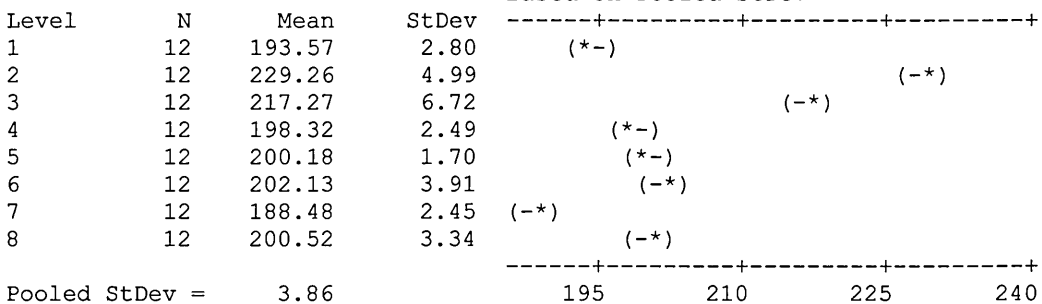

PELVIS ALIGNMENT
One-way Analysis of Variance

Analysis of Variance

Source	DF	SS	MS	F	P
Factor	7	15380.0	2197.1	77.33	0.000
Error	88	2500.3	28.4		
Total	95	17880.3			

Individual 95% CIs For Mean
Based on Pooled StDev

Level	N	Mean	StDev	CI
1	12	222.94	5.66	(-*-)
2	12	249.54	3.74	(-*-)
3	12	232.00	8.18	(-*-)
4	12	221.76	6.14	(-*-)
5	12	237.57	3.14	(-*-)
6	12	230.10	4.18	(-*-)
7	12	205.85	4.45	(-*-)
8	12	215.33	5.43	(-*-)

Pooled StDev = 5.33

210 225 240 255

FRONT KNEE ANGLE
One-way Analysis of Variance

Analysis of Variance

Source	DF	SS	MS	F	P
Factor	7	2805.27	400.75	53.48	0.000
Error	88	659.38	7.49		
Total	95	3464.65			

Individual 95% CIs For Mean
Based on Pooled StDev

Level	N	Mean	StDev	CI
1	12	167.88	2.77	(--*-)
2	12	158.12	2.77	(--*-)
3	12	157.45	3.19	(-***)
4	12	162.27	3.24	(-***)
5	12	164.76	1.92	(--*-)
6	12	159.22	1.78	(-***)
7	12	174.08	2.96	(-***)
8	12	159.17	2.89	(-***)

Pooled StDev = 2.74

156.0 162.0 168.0 174.0

CENTRE OF MASS (COM) HORIZONTAL VELOCITY
One-way Analysis of Variance

Analysis of Variance

Source	DF	SS	MS	F	P
Factor	7	48.5817	6.9402	217.74	0.000
Error	88	2.8049	0.0319		
Total	95	51.3866			

Individual 95% CIs For Mean
Based on Pooled StDev

Level	N	Mean	StDev	CI
1	12	3.9975	0.1491	(*-)
2	12	4.6358	0.1401	(*-)
3	12	4.4933	0.2643	(*-)
4	12	4.0200	0.2026	(*-)
5	12	4.1942	0.1325	(*-)
6	12	3.7425	0.1726	(*-)
7	12	3.0908	0.1325	(*-)
8	12	2.3433	0.1932	(*-)

Pooled StDev = 0.1785

2.80 3.50 4.20

TRUNK PLEXION-EXTENSION
One-way Analysis of Variance

Analysis of Variance

Source	DF	SS	MS	F	P
Factor	7	1846.48	263.78	73.03	0.000
Error	88	317.83	3.61		
Total	95	2164.31			

Individual 95% CIs For Mean
Based on Pooled StDev

Level	N	Mean	StDev	CI
1	12	9.933	1.517	(--*)
2	12	8.008	1.917	(--*)
3	12	0.358	2.050	(--*)
4	12	1.917	1.810	(--*)
5	12	5.567	2.289	(--*)
6	12	13.233	2.002	(*--)
7	12	12.742	1.808	(*--)
8	12	8.708	1.709	(*--)

Pooled StDev = 1.900

TRUNK LATERAL FLEXION
One-way Analysis of Variance

Analysis of Variance

Source	DF	SS	MS	F	P
Factor	7	959.64	137.09	34.18	0.000
Error	88	352.95	4.01		
Total	95	1312.58			

Individual 95% CIs For Mean
Based on Pooled StDev

Level	N	Mean	StDev	CI
1	12	71.975	1.629	(---*--)
2	12	67.150	1.568	(---*--)
3	12	70.008	3.794	(---*--)
4	12	68.425	2.043	(---*--)
5	12	74.350	1.251	(---*--)
6	12	74.425	1.328	(---*--)
7	12	64.792	1.271	(---*--)
8	12	70.300	1.860	(---*--)

Pooled StDev = 2.003

NON-BOWLING ARM TO HORIZONTAL
One-way Analysis of Variance

Analysis of Variance

Source	DF	SS	MS	F	P
Factor	7	14228.3	2032.6	89.87	0.000
Error	88	1990.3	22.6		
Total	95	16218.7			

Individual 95% CIs For Mean
Based on Pooled StDev

Level	N	Mean	StDev	CI
1	12	-55.317	4.475	(---*--)
2	12	-79.008	5.112	(---*--)
3	12	-85.900	7.378	(---*--)
4	12	-67.500	4.040	(---*--)
5	12	-57.667	3.786	(---*--)
6	12	-86.250	5.003	(---*--)
7	12	-57.767	3.393	(---*--)
8	12	-78.475	3.625	(---*--)

Pooled StDev = 4.756

BOWLING ARM TO HORIZONTAL
One-way Analysis of Variance

Analysis of Variance

Source	DF	SS	MS	F	P
Factor	7	5917.9	845.4	33.03	0.000
Error	88	2252.3	25.6		
Total	95	8170.2			

Individual 95% CIs For Mean
Based on Pooled StDev

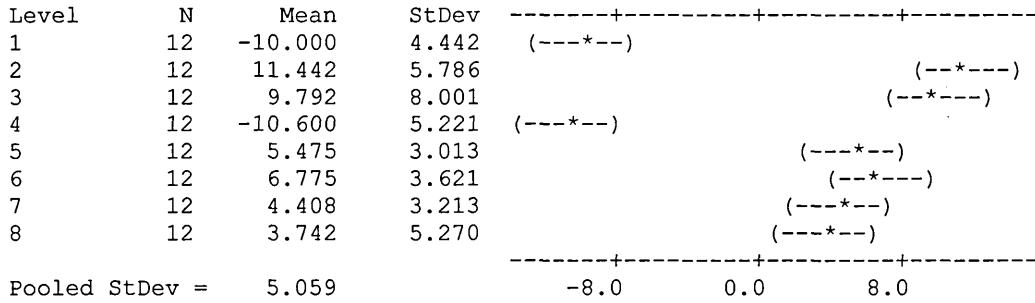

BALL RELEASE

HEIGHT OF BALL RELEASE
One-way Analysis of Variance

Analysis of Variance

Source	DF	SS	MS	F	P
Factor	7	1.15282	0.16469	120.34	0.000
Error	88	0.12043	0.00137		
Total	95	1.27325			

Individual 95% CIs For Mean
Based on Pooled StDev

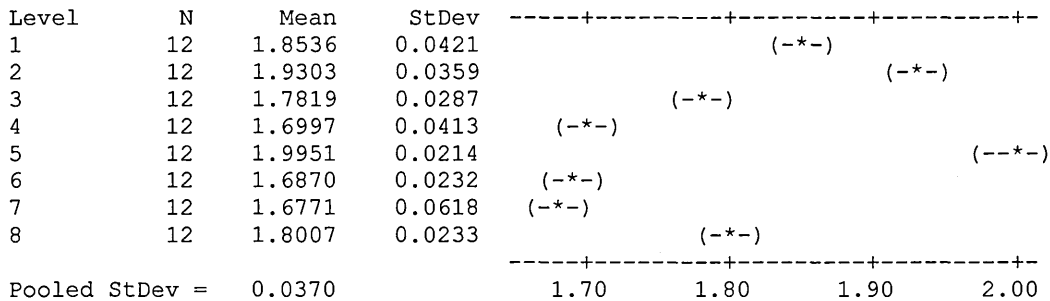

TRUNK FLEXION-EXTENSION
One-way Analysis of Variance

Analysis of Variance

Source	DF	SS	MS	F	P
Factor	7	3815.18	545.03	74.49	0.000
Error	88	643.86	7.32		
Total	95	4459.04			

Individual 95% CIs For Mean
Based on Pooled StDev

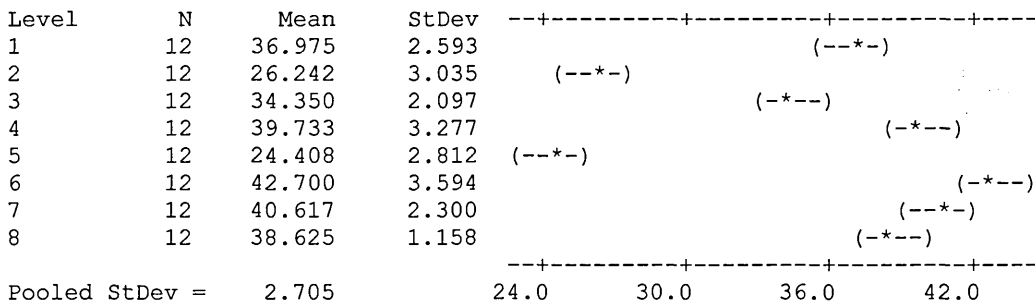

FRONT KNEE ANGLE
One-way Analysis of Variance

Analysis of Variance

Source	DF	SS	MS	F	P
Factor	7	34614.2	4944.9	121.01	0.000
Error	88	3595.9	40.9		
Total	95	38210.1			

Individual 95% CIs For Mean
Based on Pooled StDev

Level	N	Mean	StDev	CI
1	12	156.64	8.28	(--*)
2	12	133.98	4.41	(--*)
3	12	179.63	10.66	(--*)
4	12	163.13	8.39	(--*)
5	12	133.60	3.35	(--*)
6	12	182.64	1.82	(--*)
7	12	184.18	3.77	(--*)
8	12	168.20	5.11	(--*)

Pooled StDev = 6.39

144 160 176

CENTRE OF MASS (COM) HORIZONTAL VELOCITY
One-way Analysis of Variance

Analysis of Variance

Source	DF	SS	MS	F	P
Factor	7	45.7904	6.5415	305.45	0.000
Error	88	1.8846	0.0214		
Total	95	47.6750			

Individual 95% CIs For Mean
Based on Pooled StDev

Level	N	Mean	StDev	CI
1	12	3.0717	0.2291	(*-)
2	12	2.8658	0.1928	(*-)
3	12	2.6275	0.1350	(*-)
4	12	1.6133	0.1149	(*-)
5	12	2.9058	0.0990	(*-)
6	12	1.7375	0.1272	(*)
7	12	1.5458	0.1257	(*-)
8	12	1.2275	0.0921	(*-)

Pooled StDev = 0.1463

1.20 1.80 2.40 3.00

TRUNK LATERAL FLEXION
One-way Analysis of Variance

Analysis of Variance

Source	DF	SS	MS	F	P
Factor	7	2638.53	376.93	65.17	0.000
Error	88	508.99	5.78		
Total	95	3147.52			

Individual 95% CIs For Mean
Based on Pooled StDev

Level	N	Mean	StDev	CI
1	12	50.517	1.724	(--*--)
2	12	60.667	2.219	(--*--)
3	12	45.558	1.851	(--*--)
4	12	46.975	3.996	(--*--)
5	12	56.742	1.571	(--*--)
6	12	54.358	2.694	(--*--)
7	12	47.433	2.851	(--*--)
8	12	57.342	1.060	(--*--)

Pooled StDev = 2.405

45.0 50.0 55.0 60.0

OTHER

DELIVERY STRIDE LENGTH One-way Analysis of Variance

Analysis of Variance

Source	DF	SS	MS	F	P
Factor	7	0.94542	0.13506	76.59	0.000
Error	88	0.15517	0.00176		
Total	95	1.10059			

Individual 95% CIs For Mean Based on Pooled StDev

Level	N	Mean	StDev	CI
1	12	1.3465	0.0464	(--*-)
2	12	1.5473	0.0502	(--*-)
3	12	1.5534	0.0522	(-***)
4	12	1.4898	0.0325	(-**-)
5	12	1.2882	0.0460	(--*-)
6	12	1.3449	0.0468	(-***)
7	12	1.3377	0.0258	(--*-)
8	12	1.3410	0.0262	(-***)

Pooled StDev = 0.0420

DELIVERY STRIDE ALIGNMENT One-way Analysis of Variance

Analysis of Variance

Source	DF	SS	MS	F	P
Factor	7	1553.32	221.90	204.67	0.000
Error	88	95.41	1.08		
Total	95	1648.72			

Individual 95% CIs For Mean Based on Pooled StDev

Level	N	Mean	StDev	CI
1	12	170.75	1.35	(-*)
2	12	171.87	0.85	(-*)
3	12	179.12	0.60	(-*)
4	12	181.09	0.93	(-*)
5	12	173.50	0.80	(-*)
6	12	174.09	1.19	(*-)
7	12	174.65	1.30	(-*)
8	12	167.90	1.08	(-*)

Pooled StDev = 1.04

MAXIMUM RIGHT HIP SPEED One-way Analysis of Variance

Analysis of Variance

Source	DF	SS	MS	F	P
Factor	7	65.7192	9.3885	262.19	0.000
Error	88	3.1511	0.0358		
Total	95	68.8702			

Individual 95% CIs For Mean Based on Pooled StDev

Level	N	Mean	StDev	CI
1	12	5.9167	0.2652	(*)
2	12	6.0483	0.2048	(-*)
3	12	6.1258	0.2355	(-*)
4	12	5.5783	0.1281	(-*)
5	12	6.0517	0.1350	(-*)
6	12	5.1300	0.2180	(*)
7	12	4.5117	0.1231	(*-)
8	12	3.6833	0.1463	(*)

Pooled StDev = 0.1892

MAXIMUM RIGHT SHOULDER SPEED
One-way Analysis of Variance

Analysis of Variance

Source	DF	SS	MS	F	P
Factor	7	37.7071	5.3867	207.73	0.000
Error	88	2.2820	0.0259		
Total	95	39.9891			

Individual 95% CIs For Mean
Based on Pooled StDev

Level	N	Mean	StDev	CI
1	12	7.9842	0.1153	(*-)
2	12	8.1342	0.1253	(-*)
3	12	8.9025	0.1609	(*-)
4	12	7.7825	0.1791	(-*)
5	12	7.8800	0.1132	(*-)
6	12	8.3517	0.2202	(*-)
7	12	6.8758	0.1812	(-*)
8	12	6.9950	0.1623	(-*)

Pooled StDev = 0.1610

7.20 7.80 8.40

MAXIMUM RIGHT WRIST SPEED
One-way Analysis of Variance

Analysis of Variance

Source	DF	SS	MS	F	P
Factor	7	66.555	9.508	78.48	0.000
Error	88	10.661	0.121		
Total	95	77.216			

Individual 95% CIs For Mean
Based on Pooled StDev

Level	N	Mean	StDev	CI
1	12	20.041	0.330	(--*-)
2	12	18.998	0.369	(-***)
3	12	20.762	0.241	(--*-)
4	12	20.050	0.446	(--*-)
5	12	20.178	0.132	(-***)
6	12	21.224	0.393	(-***)
7	12	18.734	0.416	(-***)
8	12	19.027	0.349	(-***)

Pooled StDev = 0.348

19.20 20.00 20.80

MAXIMUM PELVIS-UPPER TORSO SEPARATION ANGLE
One-way Analysis of Variance

Analysis of Variance

Source	DF	SS	MS	F	P
Factor	7	5232.7	747.5	44.66	0.000
Error	88	1473.1	16.7		
Total	95	6705.8			

Individual 95% CIs For Mean
Based on Pooled StDev

Level	N	Mean	StDev	CI
1	12	33.350	5.722	(--*-)
2	12	26.250	3.569	(-***)
3	12	15.592	3.616	(-***)
4	12	26.617	3.891	(-***)
5	12	38.300	3.006	(-***)
6	12	28.467	2.690	(-***)
7	12	25.108	4.366	(-***)
8	12	15.267	4.990	(-***)

Pooled StDev = 4.091

16.0 24.0 32.0 40.0

MINIMUM UPPER TORSO ALIGNMENT
One-way Analysis of Variance

Analysis of Variance

Source	DF	SS	MS	F	P
Factor	7	3035.10	433.59	93.38	0.000
Error	88	408.60	4.64		
Total	95	3443.69			

Individual 95% CIs For Mean
Based on Pooled StDev

Level	N	Mean	StDev	CI
1	12	181.43	1.35	(--*)
2	12	199.20	3.40	(--*)
3	12	191.05	2.19	(--*)
4	12	188.41	3.15	(--*)
5	12	188.33	0.92	(--*)
6	12	184.64	2.06	(--*)
7	12	180.29	1.31	(--*)
8	12	185.21	1.49	(--*)

Pooled StDev = 2.15

180.0 186.0 192.0 198.0

MINIMUM PELVIS ALIGNMENT
One-way Analysis of Variance

Analysis of Variance

Source	DF	SS	MS	F	P
Factor	7	4635.46	662.21	93.66	0.000
Error	88	622.20	7.07		
Total	95	5257.66			

Individual 95% CIs For Mean
Based on Pooled StDev

Level	N	Mean	StDev	CI
1	12	179.93	1.57	(--*)
2	12	190.29	2.67	(--*)
3	12	189.16	2.45	(--*)
4	12	191.08	4.19	(--*)
5	12	190.56	2.80	(--*)
6	12	185.56	2.01	(--*)
7	12	171.89	3.07	(--*)
8	12	176.11	1.42	(--*)

Pooled StDev = 2.66

175.0 182.0 189.0

MAXIMUM PELVIS ANGULAR VELOCITY
One-way Analysis of Variance

Analysis of Variance

Source	DF	SS	MS	F	P
Factor	7	90.26	12.89	11.12	0.000
Error	88	102.03	1.16		
Total	95	192.29			

Individual 95% CIs For Mean
Based on Pooled StDev

Level	N	Mean	StDev	CI
1	12	10.894	0.812	(---*---)
2	12	9.593	1.719	(---*---)
3	12	10.431	0.733	(---*---)
4	12	10.315	0.968	(---*---)
5	12	9.028	1.069	(---*---)
6	12	10.548	0.949	(---*---)
7	12	12.458	0.777	(---*---)
8	12	9.703	1.241	(---*---)

Pooled StDev = 1.077

9.0 10.5 12.0 13.5

MAXIMUM UPPER TORSO ANGULAR VELOCITY
One-way Analysis of Variance

Analysis of Variance

Source	DF	SS	MS	F	P
Factor	7	549.08	78.44	63.63	0.000
Error	88	108.48	1.23		
Total	95	657.56			

Individual 95% CIs For Mean
Based on Pooled StDev

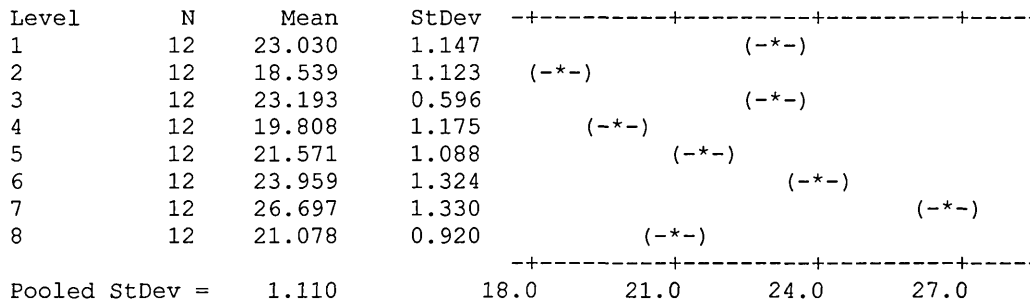

MAXIMUM TRUNK ANGULAR VELOCITY
One-way Analysis of Variance

Analysis of Variance

Source	DF	SS	MS	F	P
Factor	7	118.770	16.967	111.31	0.000
Error	88	13.414	0.152		
Total	95	132.184			

Individual 95% CIs For Mean
Based on Pooled StDev

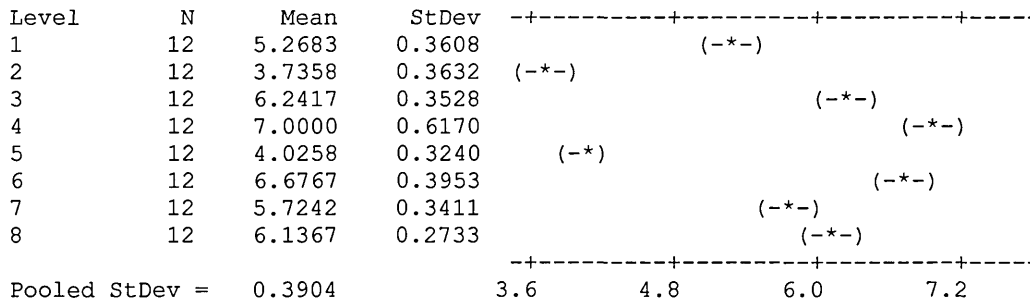

MAXIMUM VERTICAL SPEED OF THE NON-BOWLING ARM
One-way Analysis of Variance

Analysis of Variance

Source	DF	SS	MS	F	P
Factor	7	17.8724	2.5532	48.13	0.000
Error	88	4.6684	0.0531		
Total	95	22.5408			

Individual 95% CIs For Mean
Based on Pooled StDev

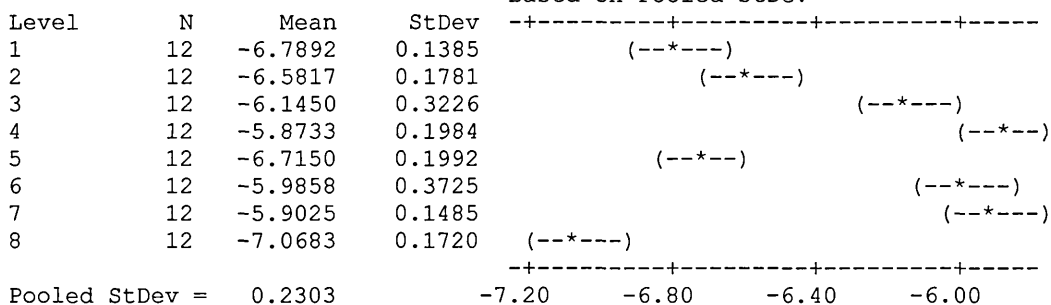

TRUNK FLEXION-EXTENSION RANGE OF MOTION (ROM)

One-way Analysis of Variance

Analysis of Variance

Source	DF	SS	MS	F	P
Factor	7	11466.88	1638.13	193.22	0.000
Error	88	746.07	8.48		
Total	95	12212.94			

Individual 95% CIs For Mean
Based on Pooled StDev

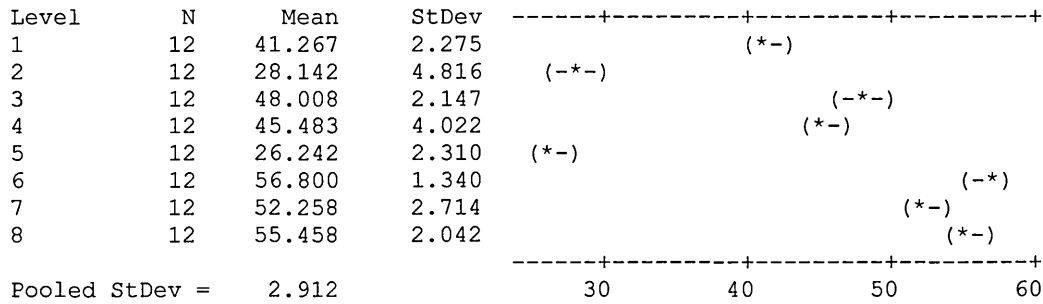

PELVIS RANGE OF MOTION (ROM)

One-way Analysis of Variance

Analysis of Variance

Source	DF	SS	MS	F	P
Factor	7	4618.9	659.8	33.52	0.000
Error	88	1732.2	19.7		
Total	95	6351.1			

Individual 95% CIs For Mean
Based on Pooled StDev

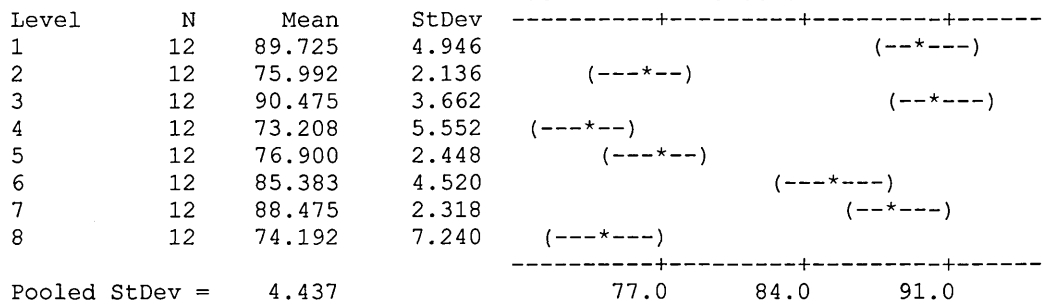

UPPER TORSO RANGE OF MOTION (ROM)

One-way Analysis of Variance

Analysis of Variance

Source	DF	SS	MS	F	P
Factor	7	11241.8	1606.0	49.63	0.000
Error	88	2847.6	32.4		
Total	95	14089.4			

Individual 95% CIs For Mean
Based on Pooled StDev

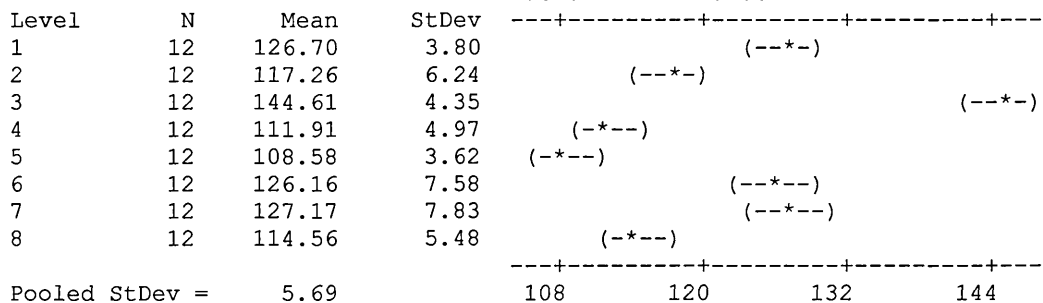

Appendix G

Kohonen Self-Organising Map Matlab Code

```
% %INTRA-INDIVIDUAL VARIABILITY
```

```
newData1 = importdata('C:\Users\Paul\Desktop\SOM_data\AB\AB02.txt')  
data = getTripledData(newData1.data);
```

```
newData1 = importdata('C:\Users\Paul\Desktop\SOM_data\AB\AB03.txt')  
data = [data;getTripledData(newData1.data)];
```

```
newData1 = importdata('C:\Users\Paul\Desktop\SOM_data\AB\AB04.txt')  
data = [data;getTripledData(newData1.data)];
```

```
newData1 = importdata('C:\Users\Paul\Desktop\SOM_data\AB\AB05.txt')  
data = [data;getTripledData(newData1.data)];
```

```
newData1 = importdata('C:\Users\Paul\Desktop\SOM_data\AB\AB06.txt')  
data = [data;getTripledData(newData1.data)];
```

```
newData1 = importdata('C:\Users\Paul\Desktop\SOM_data\AB\AB07.txt')  
data = [data;getTripledData(newData1.data)];
```

```
newData1 = importdata('C:\Users\Paul\Desktop\SOM_data\AB\AB08.txt')  
data = [data;getTripledData(newData1.data)];
```

```
newData1 = importdata('C:\Users\Paul\Desktop\SOM_data\AB\AB09.txt')  
data = [data;getTripledData(newData1.data)];
```

```
newData1 = importdata('C:\Users\Paul\Desktop\SOM_data\AB\AB10.txt')  
data = [data;getTripledData(newData1.data)];
```

```
newData1 = importdata('C:\Users\Paul\Desktop\SOM_data\AB\AB11.txt')  
data = [data;getTripledData(newData1.data)];
```

```
newData1 = importdata('C:\Users\Paul\Desktop\SOM_data\AB\AB12.txt')  
data = [data;getTripledData(newData1.data)];
```

```
newData1 = importdata('C:\Users\Paul\Desktop\SOM_data\AB\AB13.txt')  
data = [data;getTripledData(newData1.data)];
```

```
% Bowler AB (1-12)
```

```
newData1 = importdata('C:\Users\Paul\Desktop\SOM_data\AS\AS01.txt1')  
data = [data;getTripledData(newData1.data)];
```

```
newData1 = importdata('C:\Users\Paul\Desktop\SOM_data\AS\AS02.txt')  
data = [data;getTripledData(newData1.data)];
```

```
newData1 = importdata('C:\Users\Paul\Desktop\SOM_data\AS\AS03.txt')  
data = [data;getTripledData(newData1.data)];
```

```
newData1 = importdata('C:\Users\Paul\Desktop\SOM_data\AS\AS04.txt')  
data = [data;getTripledData(newData1.data)];
```

```
newData1 = importdata('C:\Users\Paul\Desktop\SOM_data\AS\AS05.txt')  
data = [data;getTripledData(newData1.data)];
```

```
newData1 = importdata('C:\Users\Paul\Desktop\SOM_data\AS\AS06.txt')  
data = [data;getTripledData(newData1.data)];
```

```
newData1 = importdata('C:\Users\Paul\Desktop\SOM_data\AS\AS07.txt')  
data = [data;getTripledData(newData1.data)];
```

```
newData1 = importdata('C:\Users\Paul\Desktop\SOM_data\AS\AS08.txt')  
data = [data;getTripledData(newData1.data)];
```

```
newData1 = importdata('C:\Users\Paul\Desktop\SOM_data\AS\AS09.txt')  
data = [data;getTripledData(newData1.data)];
```

```
newData1 = importdata('C:\Users\Paul\Desktop\SOM_data\AS\AS10.txt')  
data = [data;getTripledData(newData1.data)];
```

```
newData1 = importdata('C:\Users\Paul\Desktop\SOM_data\AS\AS11.txt')
```

```

data = [data;getTripledData(newData1.data)];

newData1 = importdata('C:\Users\Paul\Desktop\SOM_data\AS\AS12.txt'
data = [data;getTripledData(newData1.data)];

% Bowler AS (13-24)

newData1 = importdata('C:\Users\Paul\Desktop\SOM_data\CY\CY01.txt'
data = [data;getTripledData(newData1.data)];

newData1 = importdata('C:\Users\Paul\Desktop\SOM_data\CY\CY02.txt'
data = [data;getTripledData(newData1.data)];

newData1 = importdata('C:\Users\Paul\Desktop\SOM_data\CY\CY03.txt'
data = [data;getTripledData(newData1.data)];

newData1 = importdata('C:\Users\Paul\Desktop\SOM_data\CY\CY04.txt'
data = [data;getTripledData(newData1.data)];

newData1 = importdata('C:\Users\Paul\Desktop\SOM_data\CY\CY05.txt'
data = [data;getTripledData(newData1.data)];

newData1 = importdata('C:\Users\Paul\Desktop\SOM_data\CY\CY06.txt'
data = [data;getTripledData(newData1.data)];

newData1 = importdata('C:\Users\Paul\Desktop\SOM_data\CY\CY07.txt'
data = [data;getTripledData(newData1.data)];

newData1 = importdata('C:\Users\Paul\Desktop\SOM_data\CY\CY08.txt'
data = [data;getTripledData(newData1.data)];

newData1 = importdata('C:\Users\Paul\Desktop\SOM_data\CY\CY09.txt'
data = [data;getTripledData(newData1.data)];

newData1 = importdata('C:\Users\Paul\Desktop\SOM_data\CY\CY10.txt'
data = [data;getTripledData(newData1.data)];

newData1 = importdata('C:\Users\Paul\Desktop\SOM_data\CY\CY11.txt'
data = [data;getTripledData(newData1.data)];

newData1 = importdata('C:\Users\Paul\Desktop\SOM_data\CY\CY12.txt'
data = [data;getTripledData(newData1.data)];

% Bowler CY (25-36)

newData1 = importdata('C:\Users\Paul\Desktop\SOM_data\GH\GH01.txt'
data = [data;getTripledData(newData1.data)];

newData1 = importdata('C:\Users\Paul\Desktop\SOM_data\GH\GH02.txt'
data = [data;getTripledData(newData1.data)];

newData1 = importdata('C:\Users\Paul\Desktop\SOM_data\GH\GH03.txt'
data = [data;getTripledData(newData1.data)];

newData1 = importdata('C:\Users\Paul\Desktop\SOM_data\GH\GH04.txt'
data = [data;getTripledData(newData1.data)];

newData1 = importdata('C:\Users\Paul\Desktop\SOM_data\GH\GH05.txt'
data = [data;getTripledData(newData1.data)];

newData1 = importdata('C:\Users\Paul\Desktop\SOM_data\GH\GH06.txt'
data = [data;getTripledData(newData1.data)];

newData1 = importdata('C:\Users\Paul\Desktop\SOM_data\GH\GH07.txt'
data = [data;getTripledData(newData1.data)];

newData1 = importdata('C:\Users\Paul\Desktop\SOM_data\GH\GH08.txt'
data = [data;getTripledData(newData1.data)];

newData1 = importdata('C:\Users\Paul\Desktop\SOM_data\GH\GH09.txt'
data = [data;getTripledData(newData1.data)];

```

```

newData1 = importdata('C:\Users\Paul\Desktop\SOM_data\GH\GH10.txt'
data = [data;getTripledData(newData1.data)];

newData1 = importdata('C:\Users\Paul\Desktop\SOM_data\GH\GH11.txt'
data = [data;getTripledData(newData1.data)];

newData1 = importdata('C:\Users\Paul\Desktop\SOM_data\GH\GH12.txt1
data = [data;getTripledData(newData1.data)];

% Bowler GH (37-48)

newData1 = importdata('C:\Users\Paul\Desktop\SOM_data\NB\NB01.txt'
data = [data;getTripledData(newData1.data)];

newData1 = importdata('C:\Users\Paul\Desktop\SOM_data\NB\NB02.txt'
data = [data;getTripledData(newData1.data)];

newData1 = importdata('C:\Users\Paul\Desktop\SOM_data\NB\NB03.txt1
data = [data;getTripledData(newData1.data)];

newData1 = importdata('C:\Users\Paul\Desktop\SOM_data\NB\NB04.txt1
data = [data;getTripledData(newData1.data)];

newData1 = importdata('C:\Users\Paul\Desktop\SOM_data\NB\NB05.txt'
data = [data;getTripledData(newData1.data)];

newData1 = importdata('C:\Users\Paul\Desktop\SOM_data\NB\NB06.txt'
data = [data;getTripledData(newData1.data)];

newData1 = importdata('C:\Users\Paul\Desktop\SOM_data\NB\NB07.txt'
data = [data;getTripledData(newData1.data)];

newData1 = importdata('C:\Users\Paul\Desktop\SOM_data\NB\NB08.txt'
data = [data;getTripledData(newData1.data)];

newData1 = importdata('C:\Users\Paul\Desktop\SOM_data\NB\NB09.txt'
data = [data;getTripledData(newData1.data)];

newData1 = importdata('C:\Users\Paul\Desktop\SOM_data\NB\NB10.txt'
data = [data;getTripledData(newData1.data)];

newData1 = importdata('C:\Users\Paul\Desktop\SOM_data\NB\NB11.txt'
data = [data;getTripledData(newData1.data)];

newData1 = importdata('C:\Users\Paul\Desktop\SOM_data\NB\NB12.txt'
data = [data;getTripledData(newData1.data)];

% Bowler NB (49-60)

newData1 = importdata('C:\Users\Paul\Desktop\SOM_data\NS\NS01.txt'
data = [data;getTripledData(newData1.data)];

newData1 = importdata('C:\Users\Paul\Desktop\SOM_data\NS\NS02.txt'
data = [data;getTripledData(newData1.data)];

newData1 = importdata('C:\Users\Paul\Desktop\SOM_data\NS\NS03.txt'
data = [data;getTripledData(newData1.data)];

newData1 = importdata('C:\Users\Paul\Desktop\SOM_data\NS\NS04.txt'
data = [data;getTripledData(newData1.data)];

newData1 = importdata('C:\Users\Paul\Desktop\SOM_data\NS\NS05.txt'
data = [data;getTripledData(newData1.data)];

newData1 = importdata('C:\Users\Paul\Desktop\SOM_data\NS\NS06.txt'
data = [data;getTripledData(newData1.data)];

newData1 = importdata('C:\Users\Paul\Desktop\SOM_data\NS\NS07.txt'
data = [data;getTripledData(newData1.data)];

```

```

newData1 = importdata('C:\Users\Paul\Desktop\SOM_data\NS\NS08.txt'
data = [data;getTripledData(newData1.data)];

newData1 = importdata('C:\Users\Paul\Desktop\SOM_data\NS\NS09.txt'
data = [data;getTripledData(newData1.data)];

newData1 = importdata('C:\Users\Paul\Desktop\SOM_data\NS\NS10.txt'
data = [data;getTripledData(newData1.data)];

newData1 = importdata('C:\Users\Paul\Desktop\SOM_data\NS\NS11.txt'
data = [data;getTripledData(newData1.data)];

newData1 = importdata('C:\Users\Paul\Desktop\SOM_data\NS\NS12.txt'
data = [data;getTripledData(newData1.data)];

% Bowler NS (61-72)

newData1 = importdata('C:\Users\Paul\Desktop\SOM_data\RG\RG01.txt'
data = [data;getTripledData(newData1.data)];

newData1 = importdata('C:\Users\Paul\Desktop\SOM_data\RG\RG02.txt'
data = [data;getTripledData(newData1.data)];

newData1 = importdata('C:\Users\Paul\Desktop\SOM_data\RG\RG03.txt'
data = [data;getTripledData(newData1.data)];

newData1 = importdata('C:\Users\Paul\Desktop\SOM_data\RG\RG04.txt'
data = [data;getTripledData(newData1.data)];

newData1 = importdata('C:\Users\Paul\Desktop\SOM_data\RG\RG05.txt'
data = [data;getTripledData(newData1.data)];

newData1 = importdata('C:\Users\Paul\Desktop\SOM_data\RG\RG06.txt'
data = [data;getTripledData(newData1.data)];

newData1 = importdata('C:\Users\Paul\Desktop\SOM_data\RG\RG07.txt'
data = [data;getTripledData(newData1.data)];

newData1 = importdata('C:\Users\Paul\Desktop\SOM_data\RG\RG08.txt'
data = [data;getTripledData(newData1.data)];

newData1 = importdata('C:\Users\Paul\Desktop\SOM_data\RG\RG09.txt'
data = [data;getTripledData(newData1.data)];

newData1 = importdata('C:\Users\Paul\Desktop\SOM_data\RG\RG10.txt'
data = [data;getTripledData(newData1.data)];

newData1 = importdata('C:\Users\Paul\Desktop\SOM_data\RG\RG11.txt'
data = [data;getTripledData(newData1.data)];

newData1 = importdata('C:\Users\Paul\Desktop\SOM_data\RG\RG12.txt'
data = [data;getTripledData(newData1.data)];

% Bowler RG (73-84)

newData1 = importdata('C:\Users\Paul\Desktop\SOM_data\RW\RW01.txt'
data = [data;getTripledData(newData1.data)];

newData1 = importdata('C:\Users\Paul\Desktop\SOM_data\RW\RW02.txt'
data = [data;getTripledData(newData1.data)];

newData1 = importdata('C:\Users\Paul\Desktop\SOM_data\RW\RW03.txt'
data = [data;getTripledData(newData1.data)];

newData1 = importdata('C:\Users\Paul\Desktop\SOM_data\RW\RW04.txt'
data = [data;getTripledData(newData1.data)];

newData1 = importdata('C:\Users\Paul\Desktop\SOM_data\RW\RW05.txt'
data = [data;getTripledData(newData1.data)];

newData1 = importdata('C:\Users\Paul\Desktop\SOM_data\RW\RW06.txt'

```

```

data = [data;getTripledData(newData1.data)];

newData1 = importdata('C:\Users\Paul\Desktop\SOM_data\RW\RW07.txt');
data = [data;getTripledData(newData1.data)];

newData1 = importdata('C:\Users\Paul\Desktop\SOM_data\RW\RW08.txt');
data = [data;getTripledData(newData1.data)];

newData1 = importdata('C:\Users\Paul\Desktop\SOM_data\RW\RW09.txt');
data = [data;getTripledData(newData1.data)];

newData1 = importdata('C:\Users\Paul\Desktop\SOM_data\RW\RW10.txt');
data = [data;getTripledData(newData1.data)];

newData1 = importdata('C:\Users\Paul\Desktop\SOM_data\RW\RW11.txt');
data = [data;getTripledData(newData1.data)];

newData1 = importdata('C:\Users\Paul\Desktop\SOM_data\RW\RW12.txt');
data = [data;getTripledData(newData1.data)];

% Bowler RW (85-96)

%create a structure to use with the SOM
som_data = som_data_struct(data);
som_data = som_normalize(som_data, 'var');

% create the SOM
som = som_make(som_data);
map_rows = som.topol.msize(1);
map_cols = som.topol.msize(2);
som_show(som, 'umati', 'all')

counter = 1;
for i=85:96
    DataForMean(:, :, counter)=som_data.data(((i-1)*90)+1:((i-1)*90)+90, :);
    counter=counter+1;
end

[x,y,z] = size(DataForMean);

for j = 1:z
    som_show_add('traj', som_bmus(som, DataForMean(:, :, j)), 'TrajWidth', 1);
end

MeanData = mean(DataForMean, 3);
som_show_add('traj', som_bmus(som, MeanData), 'TrajWidth', 3);

```

Appendix H

Cross-Correlation Data Sets

Table H.1. Peak phase-lagged cross-correlation coefficients for each of the 4 segment couplings for 12 trials performed by participant 1. Pearson product-moment correlation coefficients (r) calculated between Z-transformed analogues and ball release speed.

Cross-Correlation Coefficients (+/- Lag)					
Trial	Ball Release Speed (m.s ⁻¹)	NBA vs. FL	BA vs. NBA	BA vs. FL	UT vs. P
1	33.06	0.996 (0)	-0.959 (0)	-0.952 (0)	0.788 (0)
2	34.00	0.991 (0)	-0.960 (0)	-0.935 (0)	0.786 (-2)
3	33.53	0.991 (0)	-0.953 (0)	-0.941 (0)	0.848 (0)
4	33.14	0.979 (0)	-0.955 (0)	-0.914 (0)	0.760 (-7)
5	33.47	0.996 (0)	-0.951 (0)	-0.954 (0)	0.852 (0)
6	34.00	0.977 (0)	-0.946 (0)	-0.883 (0)	0.796 (-2)
7	34.00	0.997 (0)	-0.959 (0)	-0.955 (0)	0.775 (0)
8	34.00	0.978 (0)	-0.959 (0)	-0.902 (0)	0.825 (-1)
9	34.11	0.994 (0)	-0.969 (0)	-0.959 (0)	0.720 (-5)
10	32.31	0.964 (0)	-0.952 (0)	-0.871 (0)	0.847 (-1)
11	34.53	0.998 (0)	-0.951 (0)	-0.944 (0)	0.814 (0)
12	34.53	0.979 (0)	-0.947 (0)	-0.944 (0)	0.818 (0)
M ± SD	33.72 ± 0.649	0.991 ± 0.445	-0.956 ± 0.078	-0.934 ± 0.200	0.806 ± 0.109
Range	32.31 / 34.53	0.964 / 0.998	-0.946 / -0.969	-0.871 / -0.959	0.720 / 0.852
r-value	-	0.323	-0.033	-0.386	-0.266
P-value	-	0.306	0.921	0.215	0.407

NB. Mean and SD are backtransformed values.

Table H.2. Peak phase-lagged cross-correlation coefficients for each of the 4 segment couplings for 12 trials performed by participant 2. Pearson product-moment correlation coefficients (r) calculated between Z-transformed analogues and ball release speed.

Cross-Correlation Coefficients (+/- Lag)					
Trial	Ball Release Speed (m.s ⁻¹)	NBA vs. FL	BA vs. NBA	BA vs. FL	UT vs. P
1	29.61	0.778 (0)	-0.980 (0)	-0.749 (0)	0.747 (-9)
2	30.64	0.978 (0)	-0.978 (0)	-0.950 (0)	0.777 (-8)
3	29.06	0.919 (0)	-0.974 (0)	-0.880 (0)	0.814 (-7)
4	29.58	0.995 (0)	-0.978 (0)	-0.968 (0)	0.745 (-10)
5	29.78	0.987 (0)	-0.979 (0)	-0.959 (0)	0.846 (-2)
6	29.33	0.991 (0)	-0.980 (0)	-0.959 (0)	0.740 (-8)
7	30.14	0.982 (0)	-0.985 (0)	-0.959 (0)	0.779 (-9)
8	30.33	0.980 (0)	-0.976 (0)	-0.953 (0)	0.815 (-5)
9	31.61	0.956 (0)	-0.979 (0)	-0.940 (0)	0.828 (-2)
10	31.22	0.974 (0)	-0.979 (0)	-0.951 (0)	0.785 (-9)
11	29.69	0.964 (0)	-0.966 (0)	-0.941 (0)	0.801 (-8)
12	31.14	0.936 (0)	-0.981 (0)	-0.891 (0)	0.803 (-5)
M ± SD	30.18 ± 0.817	0.972 ± 0.483	-0.978 ± 0.098	-0.938 ± 0.302	0.792 ± 0.091
Range	29.06 / 31.61	0.778 / 0.995	-0.966 / -0.985	-0.749 / -0.968	0.740 / 0.846
r-value	-	-0.104	-0.272	-0.095	0.297
P-value	-	0.747	0.396	0.770	0.347

NB. Mean and SD are backtransformed values.

Table H.3. Peak phase-lagged cross-correlation coefficients for each of the 4 segment couplings for 12 trials performed by participant 3. Pearson product-moment correlation coefficients (r) calculated between Z-transformed analogues and ball release speed.

Cross-Correlation Coefficients (+/- Lag)					
Trial	Ball Release Speed (m.s ⁻¹)	NBA vs. FL	BA vs. NBA	BA vs. FL	UT vs. P
1	30.11	0.254 (+19)	-0.982 (0)	-0.309 (0)	0.921 (0)
2	31.75	0.769 (+4)	-0.972 (0)	-0.875 (0)	0.932 (0)
3	33.06	0.554 (+15)	-0.984 (0)	-0.579 (0)	0.872 (0)
4	33.11	0.839 (+2)	-0.976 (0)	-0.921 (0)	0.945 (0)
5	31.31	0.696 (+12)	-0.974 (0)	-0.754 (0)	0.903 (0)
6	31.92	0.415 (+15)	-0.971 (0)	-0.432 (+10)	0.932 (0)
7	32.64	0.599 (+17)	-0.977 (0)	-0.603 (+2)	0.925 (0)
8	32.44	0.753 (+2)	-0.971 (0)	-0.861 (0)	0.920 (0)
9	32.17	0.669 (+13)	-0.969 (0)	-0.710 (0)	0.936 (0)
10	32.78	0.717 (+7)	-0.965 (0)	-0.840 (0)	0.914 (0)
11	30.22	0.606 (+14)	-0.960 (0)	-0.687 (0)	0.942 (0)
12	33.03	0.629 (+7)	-0.982 (0)	-0.712 (0)	0.903 (0)
M ± SD	32.05 ± 1.041	0.647 ± 0.253	-0.974 ± 0.140	-0.733 ± 0.361	0.922 ± 0.125
Range	30.11 / 33.11	0.254 / 0.839	-0.960 / -0.984	-0.309 / -0.921	0.872 / 0.945
r-value	-	0.490	-0.263	-0.427	-0.289
P-value	-	0.106	0.409	0.166	0.362

NB. Mean and SD are backtransformed values.

Table H.4. Peak phase-lagged cross-correlation coefficients for each of the 4 segment couplings for 12 trials performed by participant 4. Pearson product-moment correlation coefficients (r) calculated between Z-transformed analogues and ball release speed.

Cross-Correlation Coefficients (+/- Lag)					
Trial	Ball Release Speed (m.s ⁻¹)	NBA vs. FL	BA vs. NBA	BA vs. FL	UT vs. P
1	30.56	0.911 (0)	-0.965 (0)	-0.975 (0)	0.672 (-10)
2	30.33	0.907 (0)	-0.960 (0)	-0.958 (0)	0.743 (-4)
3	30.22	0.960 (0)	-0.959 (0)	-0.923 (0)	0.801 (0)
4	31.72	0.937 (0)	-0.956 (0)	-0.937 (0)	0.760 (-7)
5	31.56	0.932 (0)	-0.962 (0)	-0.976 (0)	0.707 (-4)
6	31.31	0.975 (0)	-0.957 (0)	-0.932 (0)	0.711 (-5)
7	31.14	0.908 (0)	-0.950 (0)	-0.966 (0)	0.771 (-5)
8	30.64	0.904 (0)	-0.964 (0)	-0.921 (0)	0.714 (-5)
9	30.28	0.763 (0)	-0.966 (0)	-0.644 (0)	0.668 (-5)
10	30.50	0.774 (0)	-0.958 (0)	-0.806 (0)	0.819 (-1)
11	31.11	0.958 (0)	-0.967 (0)	-0.947 (0)	0.667 (-6)
12	31.00	0.918 (0)	-0.960 (0)	-0.960 (0)	0.737 (-8)
M ± SD	30.86 ± 0.512	0.920 ± 0.330	-0.961 ± 0.061	-0.937 ± 0.398	0.735 ± 0.113
Range	30.22 / 31.72	0.763 / 0.975	-0.950 / -0.967	-0.644 / -0.976	0.667 / 0.819
r-value	-	0.458	0.321	-0.453	-0.141
P-value	-	0.134	0.308	0.139	0.662

NB. Mean and SD are backtransformed values.

Table H.5. Peak phase-lagged cross-correlation coefficients for each of the 4 segment couplings for 12 trials performed by participant 5. Pearson product-moment correlation coefficients (r) calculated between Z-transformed analogues and ball release speed.

Cross-Correlation Coefficients (+/- Lag)					
Trial	Ball Release Speed (m.s ⁻¹)	NBA vs. FL	BA vs. NBA	BA vs. FL	UT vs. P
1	31.47	0.767 (0)	-0.987 (0)	-0.705 (-17)	0.621 (-17)
2	31.06	0.433 (-20)	-0.963 (0)	-0.290 (-20)	0.782 (-8)
3	30.50	0.640 (-20)	-0.980 (0)	-0.579 (-20)	0.616 (-16)
4	31.39	0.479 (-20)	-0.980 (0)	-0.375 (-20)	0.653 (-14)
5	31.39	0.705 (-9)	-0.973 (0)	-0.655 (-20)	0.693 (-14)
6	31.39	0.578 (-20)	-0.976 (0)	-0.497 (-20)	0.716 (-12)
7	31.39	0.595 (-20)	-0.979 (0)	-0.532 (-20)	0.690 (-12)
8	30.81	0.536 (-20)	-0.979 (0)	-0.462 (-20)	0.748 (-8)
9	30.92	0.580 (-20)	-0.983 (0)	-0.520 (-20)	0.668 (-16)
10	30.64	0.633 (-19)	-0.983 (0)	-0.593 (-20)	0.671 (-15)
11	30.36	0.748 (0)	-0.970 (0)	-0.620 (-20)	0.693 (-15)
12	29.78	0.533 (-19)	-0.968 (0)	-0.461 (-20)	0.696 (-11)
M ± SD	30.93 ± 0.530	0.612 ± 0.168	-0.978 ± 0.150	-0.533 ± 0.162	0.690 ± 0.094
Range	29.78 / 31.47	0.433 / 0.767	-0.963 / -0.987	-0.290 / -0.705	0.616 / 0.782
r-value	-	0.057	-0.361	-0.083	-0.017
P-value	-	0.861	0.249	0.798	0.958

NB. Mean and SD are backtransformed values.

Table H.6. Peak phase-lagged cross-correlation coefficients for each of the 4 segment couplings for 12 trials performed by participant 6. Pearson product-moment correlation coefficients (r) calculated between Z-transformed analogues and ball release speed.

Cross-Correlation Coefficients (+/- Lag)					
Trial	Ball Release Speed (m.s ⁻¹)	NBA vs. FL	BA vs. NBA	BA vs. FL	UT vs. P
1	30.75	0.985 (0)	-0.968 (0)	-0.976 (0)	0.749 (-1)
2	30.83	0.993 (0)	-0.984 (0)	-0.979 (0)	0.680 (-7)
3	31.19	0.990 (0)	-0.970 (0)	-0.982 (0)	0.747 (0)
4	31.44	0.987 (0)	-0.976 (0)	-0.980 (0)	0.747 (0)
5	31.53	0.989 (0)	-0.978 (0)	-0.988 (0)	0.716 (-4)
6	31.69	0.990 (0)	-0.977 (0)	-0.976 (0)	0.717 (-6)
7	31.56	0.990 (0)	-0.976 (0)	-0.986 (0)	0.726 (-3)
8	31.33	0.989 (0)	-0.969 (0)	-0.990 (0)	0.709 (-4)
9	31.56	0.988 (0)	-0.973 (0)	-0.987 (0)	0.795 (0)
10	31.56	0.986 (0)	-0.966 (0)	-0.985 (0)	0.769 (-1)
11	31.33	0.992 (0)	-0.978 (0)	-0.989 (0)	0.700 (-4)
12	31.67	0.995 (0)	-0.983 (0)	-0.984 (0)	0.719 (-3)
M ± SD	31.37 ± 0.308	0.990 ± 0.154	-0.975 ± 0.120	-0.984 ± 0.149	0.733 ± 0.070
Range	30.75 / 31.67	0.985 / 0.995	-0.966 / -0.984	-0.976 / -0.990	0.680 / 0.795
r-value	-	0.123	-0.061	-0.316	0.219
P-value	-	0.704	0.851	0.25	0.493

NB. Mean and SD are backtransformed values.

Table H.7. Peak phase-lagged cross-correlation coefficients for each of the 4 segment couplings for 12 trials performed by participant 7. Pearson product-moment correlation coefficients (r) calculated between Z-transformed analogues and ball release speed.

Cross-Correlation Coefficients (+/- Lag)					
Trial	Ball Release Speed (m.s ⁻¹)	NBA vs. FL	BA vs. NBA	BA vs. FL	UT vs. P
1	31.39	0.996 (0)	-0.939 (0)	-0.964 (0)	0.732 (-3)
2	31.44	0.969 (0)	-0.939 (0)	-0.991 (0)	0.683 (-4)
3	31.75	0.968 (0)	-0.943 (0)	-0.986 (0)	0.746 (-2)
4	31.31	0.998 (0)	-0.937 (0)	-0.949 (0)	0.726 (-2)
5	32.06	0.983 (0)	-0.946 (0)	-0.983 (0)	0.618 (-6)
6	32.67	0.988 (0)	-0.944 (0)	-0.981 (0)	0.668 (-3)
7	32.39	0.979 (0)	-0.927 (0)	-0.967 (0)	0.711 (-2)
8	32.53	0.967 (0)	-0.923 (0)	-0.983 (0)	0.714 (-3)
9	33.28	0.992 (0)	-0.952 (0)	-0.982 (0)	0.714 (-3)
10	33.22	0.986 (0)	-0.946 (0)	-0.987 (0)	0.509 (-11)
11	32.75	0.941 (0)	-0.937 (0)	-0.977 (0)	0.689 (-4)
12	33.25	0.970 (0)	-0.921 (0)	-0.983 (0)	0.692 (-12)
M ± SD	32.34 ± 0.739	0.984 ± 0.455	-0.938 ± 0.078	-0.980 ± 0.238	0.688 ± 0.109
Range	31.31 / 33.28	0.941 / 0.998	-0.921 / -0.952	-0.949 / -0.991	0.509 / 0.746
r-value	-	-0.357	-0.013	-0.294	-0.433
P-value	-	0.255	0.969	0.353	0.160

NB. Mean and SD are backtransformed values.

Table H.8. Peak phase-lagged cross-correlation coefficients for each of the 4 segment couplings for 12 trials performed by participant 8. Pearson product-moment correlation coefficients (r) calculated between Z-transformed analogues and ball release speed.

Cross-Correlation Coefficients (+/- Lag)					
Trial	Ball Release Speed (m.s ⁻¹)	NBA vs. FL	BA vs. NBA	BA vs. FL	UT vs. P
1	29.94	0.936 (0)	-0.971 (0)	-0.880 (0)	0.660 (-8)
2	28.53	0.957 (0)	-0.975 (0)	-0.893 (0)	0.700 (-4)
3	29.72	0.971 (0)	-0.976 (0)	-0.930 (0)	0.701 (-8)
4	29.39	0.980 (0)	-0.969 (0)	-0.926 (0)	0.736 (-5)
5	29.69	0.987 (0)	-0.974 (0)	-0.963 (0)	0.732 (-1)
6	29.31	0.981 (0)	-0.973 (0)	-0.941 (0)	0.682 (-7)
7	29.97	0.997 (0)	-0.974 (0)	-0.966 (0)	0.819 (0)
8	30.78	0.979 (0)	-0.973 (0)	-0.960 (0)	0.707 (-6)
9	30.64	0.985 (0)	-0.973 (0)	-0.947 (0)	0.707 (-2)
10	30.61	0.978 (0)	-0.972 (0)	-0.935 (0)	0.732 (-3)
11	30.83	0.978 (0)	-0.972 (0)	-0.935 (0)	0.772 (-4)
12	31.25	0.985 (0)	-0.977 (0)	-0.966 (0)	0.602 (-14)
M ± SD	30.06 ± 0.786	0.981 ± 0.357	-0.973 ± 0.041	-0.942 ± 0.214	0.717 ± 0.114
Range	28.53 / 31.25	0.936 / 0.997	-0.969 / -0.977	-0.880 / -0.966	0.602 / 0.819
r-value	-	0.223	-0.096	-0.511	-0.093
P-value	-	0.486	0.766	0.090	0.774

NB. Mean and SD are backtransformed values.

Appendix I
Vector Coding Data Sets

Table I.1. Mean coupling angle for the 4 couplings (NBA vs. FL, BA vs. NBA, BA vs. FL and UT vs. P) during the 4 phases (0-24%, 25-49%, 50-74% and 75-99%) of the delivery stride for participant 1.

Trial	Ball Release Speed (m.s ⁻¹)	Mean Coupling Angle (°)															
		NBA vs. FL				BA vs. NBA				BA vs. FL				UT vs. P			
		0-24%	25-49%	50-74%	75-99%	0-24%	25-49%	50-74%	75-99%	0-24%	25-49%	50-74%	75-99%	0-24%	25-49%	50-74%	75-99%
1	33.06	228.7	257.6	258.1	238.8	123.2	142.9	134.5	99.8	113.8	106.0	102.9	94.2	278.8	330.9	28.0	71.8
2	34.00	230.1	257.2	261.4	244.2	123.8	142.9	132.6	99.6	115.0	106.7	99.0	93.1	275.6	341.9	31.3	76.0
3	33.53	244.1	257.7	263.5	238.5	139.5	143.5	130.9	100.2	116.8	106.4	96.7	95.3	289.6	347.9	33.6	74.3
4	33.14	241.5	258.7	266.0	241.3	137.7	140.8	132.1	98.3	117.4	103.7	94.6	93.7	273.6	338.1	29.0	79.7
5	33.47	248.9	257.6	261.6	228.3	138.6	143.3	133.6	97.3	110.4	106.4	98.8	94.2	280.0	347.6	32.8	69.3
6	34.00	246.9	259.6	266.5	251.8	137.6	144.7	130.7	98.8	110.4	104.6	94.2	92.0	281.4	349.3	33.7	75.7
7	34.00	240.4	258.9	260.8	241.6	131.2	141.1	130.8	99.7	112.1	103.5	98.7	93.7	275.5	342.0	32.2	74.8
8	34.00	243.4	257.7	265.1	251.6	132.1	142.4	133.0	100.7	110.8	105.8	95.7	92.1	274.1	342.9	31.1	75.3
9	34.11	221.3	258.0	258.9	242.1	114.1	140.6	136.4	101.9	114.6	104.4	102.4	93.6	274.5	331.8	21.4	72.0
10	32.31	248.1	257.9	266.9	229.6	143.8	140.7	134.0	96.3	116.5	104.6	94.2	91.7	274.7	352.5	33.2	78.2
11	34.53	239.6	257.5	257.7	253.8	136.7	145.8	132.2	102.2	116.8	108.0	101.8	93.0	269.0	338.7	38.4	70.8
12	34.53	239.6	258.9	265.6	227.6	134.5	143.1	131.0	98.5	116.6	104.7	94.6	96.6	280.2	351.7	30.7	74.8
M	33.72	239.4	258.1	262.7	240.8	132.7	142.6	132.7	99.4	114.2	105.4	97.8	93.6	277.3	343.0	31.3	74.4
SD	0.649	8.49	0.74	3.39	8.97	8.47	1.64	1.77	1.73	2.70	1.35	3.28	1.40	5.21	7.19	4.09	3.00
r-value	-	-0.256	0.180	-0.292	0.437	-0.317	0.483	-0.307	0.644	-0.133	0.214	0.213	0.272	-0.117	-0.084	0.082	-0.365
P-value	-	0.423	0.577	0.357	0.156	0.315	0.112	0.332	0.024	0.680	0.505	0.507	0.393	0.716	0.794	0.799	0.243

Table I.2. Mean coupling angle for the 4 couplings (NBA vs. FL, BA vs. NBA, BA vs. FL and UT vs. P) during the 4 phases (0-24%, 25-49%, 50-74% and 75-99%) of the delivery stride for participant 2.

Trial	Ball Release Speed (m.s ⁻¹)	Mean Coupling Angle (°)															
		NBA vs. FL				BA vs. NBA				BA vs. FL				UT vs. P			
		0-24%	25-49%	50-74%	75-99%	0-24%	25-49%	50-74%	75-99%	0-24%	25-49%	50-74%	75-99%	0-24%	25-49%	50-74%	75-99%
1	29.61	247.1	267.1	270.6	253.7	109.7	132.3	127.6	99.9	97.0	92.6	90.0	91.8	267.4	345.7	46.9	76.6
2	30.64	266.7	264.6	264.2	258.4	126.8	134.1	125.9	99.9	91.9	95.2	94.8	91.0	286.5	356.5	52.9	78.7
3	29.06	247.3	265.0	270.0	225.8	118.6	134.2	127.2	96.5	98.6	94.9	90.4	92.6	280.3	359.3	47.4	81.5
4	29.58	260.4	263.2	264.4	252.6	124.2	133.6	124.4	100.8	96.2	96.5	94.5	92.8	294.6	348.9	50.5	83.6
5	29.78	267.0	262.0	265.5	248.0	127.4	134.8	126.0	101.1	92.4	98.0	94.0	93.5	283.5	0.3	46.1	81.4
6	29.33	264.7	264.9	264.3	259.1	120.6	135.1	126.8	102.1	92.7	95.2	94.9	91.3	281.1	342.8	52.9	75.7
7	30.14	257.2	264.6	266.4	254.7	117.6	132.4	129.4	103.7	95.6	94.9	93.4	92.4	272.5	339.5	44.0	83.1
8	30.33	269.2	263.8	264.1	255.0	128.8	135.0	127.4	100.2	90.6	96.3	95.2	91.5	268.4	350.8	48.8	77.0
9	31.61	261.0	265.6	269.6	246.3	117.5	134.5	125.7	101.4	93.7	94.3	90.7	93.6	266.4	350.3	50.6	77.3
10	31.22	262.7	265.2	268.7	243.7	125.8	131.3	126.3	98.7	94.8	94.2	91.4	92.9	285.2	2.8	50.0	85.8
11	29.69	269.1	265.3	264.4	242.3	127.3	134.0	123.0	95.3	90.5	94.5	94.5	91.2	290.5	1.6	54.0	84.9
12	31.14	261.3	264.4	269.8	246.6	125.8	132.3	129.1	99.4	95.9	95.1	90.4	91.6	277.0	357.1	51.1	77.2
M	30.18	261.1	264.6	266.8	248.9	122.5	133.6	126.5	99.9	94.1	95.1	92.8	92.2	279.4	353.0	49.6	80.2
SD	0.817	7.48	1.27	2.67*	9.14	5.74	1.27	1.80	2.29	2.60	1.34	2.08*	0.90	9.26	7.74	3.04	3.56
r-value	-	0.301	0.104	0.281	0.117	0.205	-0.319	0.147	0.168	-0.169	-0.163	-0.276	0.201	-0.298	-0.031	0.177	-0.088
P-value	-	0.342	0.746	0.377	0.718	0.524	0.312	0.648	0.602	0.599	0.611	0.385	0.529	0.347	0.924	0.582	0.785

* Not normally distributed

Table I.3. Mean coupling angle for the 4 couplings (NBA vs. FL, BA vs. FL, BA vs. NBA, BA vs. FL and UT vs. P) during the 4 phases (0-24%, 25-49%, 50-74% and 75-99%) of the delivery stride for participant 3.

Trial	Ball Release Speed (m.s ⁻¹)	Mean Coupling Angle (°)															
		NBA vs. FL				BA vs. NBA				BA vs. FL				UT vs. P			
		0-24%	25-49%	50-74%	75-99%	0-24%	25-49%	50-74%	75-99%	0-24%	25-49%	50-74%	75-99%	0-24%	25-49%	50-74%	75-99%
1	30.11	276.6	267.8	276.5	236.5	116.8	137.5	128.2	107.9	86.28	92.5	85.0	102.6	257.6	318.6	37.6	69.8
2	31.75	288.9	264.9	266.1	217.6	123.4	137.1	127.9	101.5	81.34	95.5	92.5	104.7	247.0	357.9	40.3	67.2
3	33.06	306.6	269.2	270.1	227.6	110.8	137.3	128.9	108.1	81.85	90.9	89.6	106.6	252.7	331.4	35.8	73.5
4	33.11	287.3	263.0	265.0	220.6	124.7	136.2	128.9	102.4	81.22	97.3	93.9	103.9	231.5	5.0	46.0	70.6
5	31.31	290.4	267.7	266.0	222.7	125.6	138.1	129.2	102.6	79.15	92.5	92.5	103.5	246.6	341.1	35.3	72.8
6	31.92	308.5	265.3	275.9	216.2	112.0	137.4	128.6	98.0	78.49	95.1	85.7	101.1	239.6	318.8	37.5	71.0
7	32.64	289.2	269.8	268.0	217.2	124.5	138.5	131.3	102.8	80.23	90.2	91.3	106.6	245.8	43.3	37.9	71.8
8	32.44	295.0	262.8	270.4	214.2	121.9	139.3	130.1	101.4	79.70	98.5	89.4	107.7	250.7	340.8	37.8	70.7
9	32.17	298.0	267.7	267.1	216.5	124.7	139.4	129.3	101.8	75.54	92.6	91.8	105.6	239.4	4.4	42.3	70.3
10	32.78	291.1	266.7	266.1	212.7	122.1	141.0	126.4	100.0	81.95	94.1	92.5	105.5	246.4	350.4	44.7	68.4
11	30.22	285.3	267.7	269.1	202.7	129.8	140.3	128.0	96.7	79.91	92.9	89.8	106.2	249.6	343.5	38.1	69.9
12	33.03	295.9	266.2	271.1	227.1	121.7	137.2	131.8	106.7	78.65	94.2	88.7	105.3	241.1	329.9	37.2	70.5
M	32.05	292.7	266.6	269.3	219.3	121.5	138.3	129.1	102.5	80.4	93.8	90.2	104.9	245.7	347.1	39.2	70.6
SD	1.041	8.86	2.23	3.78	8.58	5.61	1.43	1.48	3.59	2.58	2.45	2.75	1.88	6.97	23.65	3.43*	1.73
r-value	-	0.544	-0.212	-0.371	0.046	-0.201	-0.191	0.360	0.204	-0.299	0.194	0.412	0.335	-0.517	-0.333	0.326	0.210
P-value	-	0.067	0.509	0.234	0.887	0.532	0.553	0.250	0.523	0.346	0.546	0.183	0.286	0.085	0.289	0.301	0.514

Table I.4. Mean coupling angle for the 4 couplings (NBA vs. FL, BA vs. NBA, BA vs. FL and UT vs. P) during the 4 phases (0-24%, 25-49%, 50-74% and 75-99%) of the delivery stride for participant 4.

Trial	Ball Release Speed (m.s ⁻¹)	Mean Coupling Angle (°)															
		NBA vs. FL				BA vs. NBA				BA vs. FL				UT vs. P			
		0-24%	25-49%	50-74%	75-99%	0-24%	25-49%	50-74%	75-99%	0-24%	25-49%	50-74%	75-99%	0-24%	25-49%	50-74%	75-99%
1	30.56	248.6	268.4	263.8	239.4	125.2	139.3	119.9	103.0	99.9	91.3	93.7	274.2	296.3	28.6	74.2	
2	30.33	250.7	268.5	265.5	239.6	126.2	140.3	120.7	100.7	99.7	91.2	93.0	262.3	275.1	29.5	73.0	
3	30.22	247.9	267.4	264.6	256.8	127.4	141.7	122.1	102.1	101.6	92.7	94.1	263.6	263.3	28.0	69.4	
4	31.72	241.2	267.5	268.1	251.0	122.6	146.8	122.4	103.8	101.7	93.4	91.4	272.3	282.9	29.2	77.9	
5	31.56	238.6	268.4	263.8	241.2	120.6	142.2	123.5	103.1	102.9	91.7	94.5	279.0	282.0	25.7	69.7	
6	31.31	241.0	266.1	261.7	257.9	123.5	143.2	121.6	101.6	102.5	94.3	95.6	281.5	277.2	23.3	71.2	
7	31.14	260.8	267.4	265.5	240.1	136.6	142.3	122.1	100.9	96.7	92.6	93.3	275.3	276.8	24.0	74.5	
8	30.64	232.3	268.5	267.5	247.2	117.0	144.1	121.2	104.8	106.1	91.7	91.8	256.3	284.8	26.2	72.4	
9	30.28	247.8	266.8	271.7	257.2	126.3	139.8	121.4	102.6	102.7	93.7	89.5	275.5	272.7	22.2	70.3	
10	30.50	256.5	268.2	271.3	239.7	131.9	141.0	123.2	101.0	98.5	92.1	89.6	260.2	257.4	26.3	69.3	
11	31.11	244.3	267.1	265.6	250.6	124.6	140.9	118.8	105.2	103.2	93.4	92.9	276.8	281.8	22.9	69.1	
12	31.00	257.5	268.4	266.2	242.0	134.4	139.3	120.3	102.0	99.9	91.7	92.4	270.0	304.7	26.9	74.7	
M	30.86	247.3	267.7	266.2	246.9	126.3	141.7	121.4	102.6	101.3	92.5	92.6	270.6	279.6	26.1	72.1	
SD	0.512	8.38	0.79	2.98	7.49*	5.63	2.19	1.37	1.49	2.49	1.02	1.85	8.10	12.77	2.50	2.79	
r-value	-	-0.266	-0.177	-0.337	-0.020	-0.162	0.597	0.204	0.275	0.087	0.295	0.330	0.589	0.352	-0.127	0.369	
P-value	-	0.403	0.586	0.283	0.952	0.403	0.586	0.283	0.952	0.786	0.353	0.295	0.044	0.262	0.695	0.238	

* Not normally distributed

Table I.5. Mean coupling angle for the 4 couplings (NBA vs. FL, BA vs. NBA, BA vs. FL and UT vs. P) during the 4 phases (0-24%, 25-49%, 50-74% and 75-99%) of the delivery stride for participant 5.

Trial	Ball Release Speed (m.s ⁻¹)	Mean Coupling Angle (°)															
		NBA vs. FL				BA vs. NBA				BA vs. FL				UT vs. P			
		0-24%	25-49%	50-74%	75-99%	0-24%	25-49%	50-74%	75-99%	0-24%	25-49%	50-74%	75-99%	0-24%	25-49%	50-74%	75-99%
1	31.47	269.1	261.9	271.4	266.6	127.5	130.2	121.0	106.5	91.6	96.9	89.5	89.3	274.5	325.0	45.5	74.4
2	31.06	260.1	265.6	283.3	220.8	133.4	128.1	117.9	92.8	99.3	93.5	83.6	93.3	279.9	356.9	38.3	79.1
3	30.50	262.9	261.9	275.8	251.3	129.0	128.2	124.7	96.4	95.4	96.6	86.3	89.4	283.4	330.0	37.4	77.2
4	31.39	260.4	263.1	278.9	238.6	127.3	126.5	124.2	96.0	97.5	95.3	84.3	90.5	275.7	330.7	30.2	74.9
5	31.39	262.0	260.9	275.4	242.6	131.7	128.9	122.4	93.7	97.4	97.5	87.4	89.5	279.0	337.1	39.2	79.2
6	31.39	260.6	260.7	279.6	229.5	132.3	126.3	123.9	93.4	98.7	97.0	84.2	90.6	280.9	338.6	33.8	80.3
7	31.39	259.4	262.0	277.3	240.0	130.8	128.0	123.3	96.9	99.4	96.5	85.5	91.7	282.7	341.1	39.3	77.4
8	30.81	260.1	261.3	280.9	262.2	131.0	126.4	121.8	97.3	98.8	96.7	83.7	88.5	277.0	341.9	37.2	75.5
9	30.92	258.6	262.9	276.7	246.0	130.3	126.6	124.3	98.6	99.8	95.5	85.8	91.1	277.0	335.0	38.1	77.8
10	30.64	260.0	261.9	275.4	246.7	130.8	128.8	124.9	98.9	98.8	96.8	86.5	91.1	274.6	330.7	31.3	78.5
11	30.36	261.6	261.5	275.1	235.0	132.8	130.6	121.8	95.0	98.1	97.5	87.6	91.8	283.9	333.1	38.4	82.8
12	29.78	259.3	263.2	278.4	209.5	132.4	127.9	120.1	92.4	99.9	95.6	85.6	94.3	288.0	337.7	42.3	78.8
M	30.93	261.2	262.2	277.3	240.7	130.5	128.0	122.5	96.5	97.9	96.3	85.8	90.9	279.7	336.5	37.6	78.0
SD	0.530	2.76	1.33	3.11	16.10	2.54	1.44	2.12	3.82	2.35*	1.13	1.73	1.68	4.22	8.13	4.26	2.38
r-value	-	0.294	-0.145	-0.040	0.384	-0.164	-0.153	0.159	0.315	-0.318	0.048	0.006	-0.475	-0.601	0.031	-0.126	-0.360
P-value	-	0.353	0.651	0.901	0.217	0.611	0.634	0.620	0.319	0.314	0.884	0.983	0.118	0.039	0.924	0.696	0.250

* Not normally distributed

Table I.6. Mean coupling angle for the 4 couplings (NBA vs. FL, BA vs. NBA, BA vs. FL and UT vs. P) during the 4 phases (0-24%, 25-49%, 50-74% and 75-99%) of the delivery stride for participant 6.

Trial	Ball Release Speed (m.s ⁻¹)	Mean Coupling Angle (°)															
		NBA vs. FL				BA vs. NBA				BA vs. FL				UT vs. P			
		0-24%	25-49%	50-74%	75-99%	0-24%	25-49%	50-74%	75-99%	0-24%	25-49%	50-74%	75-99%	0-24%	25-49%	50-74%	75-99%
1	30.75	238.8	252.4	255.2	200.5	132.3	134.0	128.2	95.4	118.6	107.2	101.6	100.3	268.9	312.9	31.1	69.4
2	30.83	233.2	248.0	252.1	232.5	123.7	134.4	127.8	104.8	116.0	111.6	104.2	100.1	236.0	294.9	21.4	70.9
3	31.19	242.8	251.8	253.8	209.3	131.6	134.5	125.0	97.4	114.5	108.0	101.4	100.8	266.3	299.0	30.1	69.8
4	31.44	241.8	251.7	257.2	216.3	129.8	133.6	126.4	100.1	113.8	107.5	99.6	101.0	268.3	301.9	27.1	72.4
5	31.53	245.5	254.2	255.9	218.5	134.0	132.3	127.2	100.4	113.6	104.5	100.7	100.8	271.4	326.7	31.1	74.3
6	31.69	237.6	253.0	253.6	230.1	132.8	136.2	123.3	105.3	120.1	107.9	100.8	101.9	257.5	308.6	27.6	72.1
7	31.56	244.0	252.2	255.2	211.4	134.1	134.8	129.9	99.9	115.2	107.7	102.5	101.4	267.6	305.6	28.5	71.0
8	31.33	245.8	252.4	252.6	195.4	134.2	134.0	128.5	94.6	113.5	107.1	103.7	100.8	263.3	305.3	24.2	70.7
9	31.56	244.3	251.6	254.5	205.9	134.2	132.7	126.8	98.0	115.0	107.2	101.6	102.1	272.4	324.3	34.8	71.2
10	31.56	245.7	253.7	254.9	205.5	133.7	136.4	124.7	96.9	113.3	107.2	100.4	101.2	269.8	318.9	31.0	69.6
11	31.33	243.8	251.7	252.8	222.7	132.7	132.7	126.2	102.2	114.3	107.1	102.7	101.6	268.5	308.0	27.3	68.8
12	31.67	245.2	251.0	254.9	236.0	132.9	133.2	126.8	106.5	113.2	108.0	101.5	100.5	270.4	299.4	23.9	67.0
M	31.37	242.4	252.0	254.4	215.3	132.2	134.1	126.7	100.1	115.1	107.6	101.7	101.0	265.0	308.8	28.2	70.6
SD	0.308	3.93*	1.54	1.47	12.99	2.97*	1.30	1.81	3.91	2.17*	1.57*	1.36	0.61	9.98*	10.12	3.76	1.88
r-value	-	0.604	0.495	0.314	0.194	0.604	0.055	-0.341	0.270	-0.289	-0.446	-0.467	0.646	0.482	0.310	0.196	0.137
P-value	-	0.037	0.103	0.322	0.545	0.038	0.866	0.277	0.396	0.363	0.146	0.126	0.023	0.113	0.326	0.542	0.672

* Not normally distributed

Table I.7. Mean coupling angle for the 4 couplings (NBA vs. FL, BA vs. NBA, BA vs. FL and UT vs. P) during the 4 phases (0-24%, 25-49%, 50-74% and 75-99%) of the delivery stride for participant 7.

Trial	Ball Release Speed (m.s ⁻¹)	Mean Coupling Angle (°)															
		NBA vs. FL				BA vs. NBA				BA vs. FL				UT vs. P			
		0-24%	25-49%	50-74%	75-99%	0-24%	25-49%	50-74%	75-99%	0-24%	25-49%	50-74%	75-99%	0-24%	25-49%	50-74%	75-99%
1	31.39	261.7	259.5	257.8	242.9	130.4	142.7	121.2	97.1	98.3	103.7	97.8	275.9	278.6	19.5	67.0	
2	31.44	267.6	260.3	245.6	232.1	124.0	144.5	119.8	98.4	96.9	103.6	102.7	266.4	296.5	19.9	68.0	
3	31.75	272.9	260.0	253.8	238.6	131.1	142.7	120.1	100.3	90.2	103.0	99.5	272.7	288.6	21.4	68.8	
4	31.31	253.3	256.9	255.0	240.5	132.1	141.4	117.6	96.1	105.1	106.4	98.4	273.2	305.9	26.9	66.8	
5	32.06	265.4	258.0	251.2	234.6	129.6	143.9	124.5	98.4	95.5	106.2	102.7	265.0	308.0	19.3	60.9	
6	32.67	259.0	258.2	251.1	234.8	129.4	144.7	123.3	98.2	100.3	106.5	102.4	269.7	299.5	22.7	63.8	
7	32.39	267.2	256.9	248.7	230.3	136.4	142.8	120.9	94.5	95.4	106.8	102.8	273.7	302.0	16.1	66.1	
8	32.53	263.9	258.4	248.1	207.9	135.1	142.3	119.7	93.3	96.6	104.6	102.3	268.2	296.5	20.4	66.6	
9	33.28	249.0	258.7	254.4	214.9	116.8	145.0	127.6	96.0	97.7	105.9	102.3	264.5	291.9	14.5	60.5	
10	33.22	237.8	260.4	255.2	202.8	115.4	145.1	127.0	93.8	100.1	103.7	101.0	275.1	293.2	8.9	61.2	
11	32.75	277.6	260.0	248.2	229.9	128.0	144.0	121.6	97.7	86.9	103.0	103.2	268.6	295.4	17.8	68.4	
12	33.25	262.0	259.2	249.1	206.8	131.9	143.1	121.3	93.4	97.5	104.1	102.2	275.5	302.3	17.8	71.5	
M	32.34	261.4	258.9	251.5	226.4	128.3	143.5	122.0	96.4	96.7	104.8	101.4	270.7	296.5	18.8	65.8	
SD	0.739	10.74	1.22	3.71	14.25*	6.53	1.18	3.02	2.29	4.69	1.45	1.84*	4.15	8.04	4.47	3.48	
r-value	-	-0.352	0.127	-0.135	-0.806	-0.395	0.536	0.676	-0.532	-0.117	0.039	0.572	-0.070	0.116	-0.673	-0.278	
P-value	-	0.261	0.693	0.676	0.002**	0.204	0.073	0.016	0.075	0.718	0.906	0.052	0.830	0.720	0.016	0.382	

* Not normally distributed, ** adj. $P < 0.003$

Table I.8. Mean coupling angle for the 4 couplings (NBA vs. FL, BA vs. NBA, BA vs. FL and UT vs. P) during the 4 phases (0-24%, 25-49%, 50-74% and 75-99%) of the delivery stride for participant 8.

Trial	Ball Release Speed (m.s ⁻¹)	Mean Coupling Angle (°)															
		NBA vs. FL				BA vs. NBA				BA vs. FL				UT vs. P			
		0-24%	25-49%	50-74%	75-99%	0-24%	25-49%	50-74%	75-99%	0-24%	25-49%	50-74%	75-99%	0-24%	25-49%	50-74%	75-99%
1	29.94	247.3	259.9	267.8	242.9	133.6	142.3	131.3	103.4	111.9	103.3	92.3	270.5	303.4	20.5	73.6	
2	28.53	248.6	260.8	264.4	262.5	133.4	146.6	132.4	109.0	111.0	104.3	95.4	265.9	294.8	23.9	70.5	
3	29.72	251.2	262.2	265.1	251.8	131.8	143.1	129.9	106.8	107.1	100.5	94.3	268.6	304.4	25.9	73.4	
4	29.39	253.4	261.3	264.3	250.9	134.4	144.6	130.6	103.9	106.6	102.4	95.2	266.3	304.2	28.6	72.3	
5	29.69	260.1	261.8	265.2	249.4	130.7	144.5	131.2	106.7	99.8	101.7	94.3	265.7	304.7	31.1	65.2	
6	29.31	251.9	261.5	263.8	250.2	132.8	146.7	132.9	106.7	107.4	103.1	96.0	269.4	297.2	28.0	72.3	
7	29.97	255.9	262.1	262.0	254.6	141.6	142.0	132.4	106.7	107.0	100.0	97.5	273.1	308.2	30.8	66.9	
8	30.78	253.5	263.2	265.3	245.1	131.8	145.6	132.4	105.7	104.8	100.0	94.4	269.6	306.3	29.8	72.6	
9	30.64	252.1	261.8	263.2	253.3	134.4	144.8	131.4	107.5	107.8	102.0	96.2	276.5	298.3	29.1	68.6	
10	30.61	248.8	259.3	263.9	248.4	130.4	143.0	130.5	104.6	108.4	104.2	95.5	271.6	287.8	27.9	71.4	
11	30.83	253.2	261.3	265.4	249.1	136.4	143.8	129.6	106.9	107.5	102.1	94.1	273.0	307.0	28.4	72.5	
12	31.25	248.0	263.8	262.4	254.6	126.7	146.6	133.3	108.2	105.9	99.5	97.2	258.8	315.0	34.6	74.7	
M	30.06	252.0	261.6	264.4	251.1	133.1	144.5	131.5	106.3	107.1	101.9	95.2	269.1	302.6	28.2	71.2	
SD	0.786	3.65	1.24	1.54	5.04	3.62	1.69	1.20	1.68	3.02	1.64	1.45	4.59	7.11	3.61	2.87	
r-value	-	-0.083	0.344	-0.152	-0.403	-0.238	-0.126	-0.063	-0.056	-0.204	-0.497	0.118	0.108	0.375	0.515	0.241	
P-value	-	0.798	0.275	0.637	0.194	0.457	0.697	0.849	0.864	0.525	0.101	0.716	0.739	0.229	0.087	0.452	