

Novel strategies and techniques for performing elemental speciation.

WATSON, Robert P.

Available from Sheffield Hallam University Research Archive (SHURA) at:

<http://shura.shu.ac.uk/20505/>

This document is the author deposited version. You are advised to consult the publisher's version if you wish to cite from it.

Published version

WATSON, Robert P. (1998). Novel strategies and techniques for performing elemental speciation. Doctoral, Sheffield Hallam University (United Kingdom)..

Copyright and re-use policy

See <http://shura.shu.ac.uk/information.html>

REFERENCE

Fines are charged at 50p per hour

^fo k|o < o fS&vv,,

ProQuest Number: 10701152

All rights reserved

INFORMATION TO ALL USERS

The quality of this reproduction is dependent upon the quality of the copy submitted.

In the unlikely event that the author did not send a complete manuscript and there are missing pages, these will be noted. Also, if material had to be removed, a note will indicate the deletion.

uest

ProQuest 10701152

Published by ProQuest LLC(2017). Copyright of the Dissertation is held by the Author.

All rights reserved.

This work is protected against unauthorized copying under Title 17, United States Code
Microform Edition © ProQuest LLC.

ProQuest LLC.
789 East Eisenhower Parkway
P.O. Box 1346
Ann Arbor, MI 48106- 1346

**NOVEL STRATEGIES AND TECHNIQUES FOR
PERFORMING ELEMENTAL SPECIATION**

Robert Paul Watson

A thesis submitted in partial fulfilment of the requirements of

Sheffield Hallam University

for the degree of Doctor of Philosophy

March 1998

Collaborating Organisation: Spectro Analytical

Kleve

Germany.

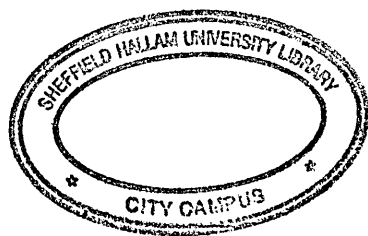

Acknowledgements

I would like to extend thanks to Professor Cameron McLeod, and to Mr Collin D'Silva for their patience and support while waiting for me to write this thesis. I would also like to thank all the technicians and post graduate students who worked in Professor McLeod's research group, with a special mention to Dr Mariluz Mena for preparing the sulphhydryl cotton. I would also like to acknowledge the help and support of Professor Heinz Falk and the staff at SpectroAnalytical during my time in Kleve. I would also like to thank my work colleagues for their regular and frequent encouragement to me to finish my thesis. Finally, a special thanks to all my friends and family who have helped me with a special mention to Sarah.

ABSTRACT

Novel Strategies and Techniques for Performing Elemental Speciation.

Robert Paul Watson

This thesis reports on the hyphenation of well known individual techniques into novel combinations which allow the creation of new strategies and techniques for performing speciation analysis. Speciation analysis is a relatively new and exciting area of analytical chemistry which gives the analyst a greater understanding of the impact of elemental species on the environment.

The use of microcolumns filled with either acidic alumina or sulphhydryl cotton to preconcentrate and separate selenium(IV) and selenium(VI) species is reported. The microcolumns were incorporated into flow analysis systems using inductively coupled plasma - mass spectrometry (ICP-MS) for detection of the selenium-82 isotope. With optimised conditions the limits of detection for selenium(VI) using the alumina microcolumn was 8 ng/l while selenium(IV) was separated from selenium(VI) using the sulphhydryl cotton microcolumn and gave a detection limit of 15 ng/l.

Preliminary results from the combination of gel electrophoresis with laser ablation ICP-MS are reported. This novel combination of the separation technique of gel electrophoresis with the localised solid analysis of laser ablation, gave us the ability to identify and quantify cobalt-protein complexes. The limit of detection for cobalt in the electrophoretic gel was 8 µg/l. The resolution for mapping a crossed immunoelectrophoretic gel was 1 mm.

Preliminary studies into the novel combination of electrothermal vaporisation with time-of-flight mass spectrometry are reported. This system gave the ability to perform multielement elemental analysis on small volumes (10 μl) of sample giving detection limits in the $\mu\text{g/l}$ range. Then by changing the instrumental parameters the instrument performed speciation analysis on different chromium complexes and identified the chromium and copper species in a simple standard mixture.

CONTENTS	PAGE
1. INTRODUCTION.	2
1.1. Trace Analysis and Chemical Speciation	3
1.2. Strategies for Chemical Speciation.	8
1.2.1. Atomic Spectroscopy.	8
1.2.2. Chromatography.	17
1.2.3. Flow Injection.	20
1.2.4. Separation in the Solid State	27
1.3. Conclusions.	31
1.4. Aims and Objectives of This Work.	31
1.5. References	33
2. SPECIATION VIA FLOW ANALYSIS.	38
2.1. Introduction.	39
2.2. Experimental	51
2.3. Results and Discussion.	61
2.3.1. Deposition/Elution of Selenium IV and VI on Acidic Alumina.	61
2.3.2. Analytical Performance.	66
2.3.3. Deposition/Elution of Selenium Species on Sulphydryl Cotton Fibre.	72
2.3.4. Analytical Performance.	75
2.4. Conclusions and Further Work.	77
2.5. References.	81
3. SPECIATION VIA LASER ABLATION-ICP-MASS SPECTROMETRY.	86
3.1. Introduction.	87
3.2. Experimental	96
3.2.1. Laser Focusing.	98
3.3. Results and Discussion.	100
3.3.1. Optimisation of Laser Ablation.	100
3.3.2. One-Dimensional Electrophoretograms	103
3.3.3. Mapping.	109
3.3. Conclusions.	113
3.4. References.	115

4. SPECIATION VIA ELECTROTHERMAL VAPORISATION - TIME OF FLIGHT - MASS SPECTROMETRY.	118
4.1. Introduction	119
4.2. Experimental.	123
4.2.1. Sample Introduction.	124
4.2.2. Ion Source.	124
4.3. Results and Discussion	126
4.3.1. Ionisation and Fragmentation	126
4.3.2. Reproducibility of the Coils.	129
4.3.3. Calibration Curves for Ag, Cu, Mg and Pb	129
4.3.4. Vaporisation profiles.	132
4.3. Speciation.	139
4.3.1. Chromium.	139
4.3.2. Chromium - Copper mixtures	147
4.4. Conclusion and Future Work.	150
4.5. References.	152
5. CONCLUSIONS AND FUTURE WORK.	153

1. INTRODUCTION.	2
1.1. Trace Analysis and Chemical Speciation	3
1.2. Strategies for Chemical Speciation.	8
1.2.1. Atomic Spectroscopy.	8
1.2.2. Separation Techniques.	17
1.2.3. Flow Injection.	20
1.2.4. Separation in the Solid State	27
1.3. Conclusions.	31
1.4. Aims and Objectives of This Work.	31
1.5. References	33

Speciation analysis is a relatively new and exciting area of analytical chemistry. The analyst is no longer only interested in the total concentration of an analyte present in a sample, but in what form the analyte is present as. This gives the analyst a greater understanding of the impact of elemental species on the environment, and allows for greater controls to be taken to protect the environment from harmful levels of these species.

The species can be defined either functionally, operationally, or as specific chemical compounds. Functionally defined species are those species known as 'biologically active' or 'mobile' forms. In operationally defined speciation, the chemical or physical process applied to the sample defines the species, i.e. 'water/acid soluble', 'reducible', etc. The third form of speciation, in which the precise chemical form of the element present is defined or measured, is the hardest to achieve and requires analytical techniques of great selectivity and sensitivity. It is this form of speciation which will be covered in this thesis.

1.1. Trace Analysis and Chemical Speciation

It is now realised that distribution, mobility and the bioavailability of elements depends not only on their concentration in the environment but also on the form in which they are present. This has resulted in the field of elemental speciation being the focus of considerable recent research. Speciation has been defined in many ways, most recently by Ure *et al.*^[1,2] as either (a) "the process of identifying and quantifying the different, defined species, forms or phases present in a material"; or (b) "the description of the amounts and kinds of these species, forms or phases present".

Unlike most other potential toxic compounds released into the environment, metals are not biodegradable, and therefore, remain a constant potential threat to life. Some elements however are essential to life, these are shown in Table I.

Elements Essential to Life	Suspected to be Essential to Life
Fe, I, Cu, Mn, Zn, Co, Mo, Se, Cr, Sn, V, F, Si, Ni.	As, Cd, Pb, W.

Table I Elements essential to life.

However, most of these elements in excess can be extremely toxic. The potential toxicity of such metals is very much dependent on their physio-chemical form.^[3]

There is great interest in the speciation of arsenic due to the varying levels of toxicity of each species. The major arsenic species in the environment are arsenite (As III), arsenate (As V), dimethylarsinate (DMA), monomethylarsonate (MMA), arsenobetaine (AsBet) and arsenocholine (AsChol). Arsenite and arsenate are extremely toxic, arsenite being more toxic than arsenate as it interacts with sulphhydryl groups in cells and so inhibits sulphhydryl containing enzyme systems, essential to cellular metabolism. Dimethylarsinate and MMA are moderately toxic, while AsBet and AsChol are virtually non-toxic. A variety of techniques have been used to determine the various species of arsenic, the most common being the formation of volatile hydrides of several species, with separation by gas chromatography and detection by atomic absorption spectrometry. High performance liquid chromatography (HPLC) has been interfaced with a variety of detectors including atomic absorption spectrometry (AAS), inductively coupled plasma atomic emission spectrometry (ICP-AES) and inductively coupled plasma mass spectrometry (ICP-MS).

High performance liquid chromatography was used by Le *et al.*^[4] to separate As(III), As(V), MMA, DMA and AsBet using microwave heating to aid the hydride generation of all of the species prior to AAS detection. Violante *et al.*^[5] and Rubio *et al.*^[6] both used u.v. photo-oxidation to aid the hydride generation of the species separated by HPLC. High performance liquid chromatography coupled to ICP-MS was also used by

Branch *et al.*^[7] to determine the organo-arsenic species concentrations in fish, inorganic-arsenic was calculated by difference from a separate total arsenic determination. A column of chromaton N-AW-HMDS was used by Russeva *et al.*^[8] to selectively retain As(V), while arsenite was not retained; arsenate was subsequently eluted with dilute HCl and detection was by graphite furnace-AAS. Graphite furnace-AAS was also used by Han *et al.*^[9] to determine the arsenic species concentration in 40 fractions of eluate collected from an anion exchange column.

Chromium in its trivalent state is essential to life, forming an essential link in the normal glucose tolerance factor (GTF) of man.^[10] Chromium(III) is considered to be non-toxic to man. Hexavalent chromium on the other hand is extremely toxic, forming chromium-DNA adducts to produce genetic damage.^[11] Various workers have preconcentrated the chromium species using columns of various materials to increase detection limits. Cox and McLeod^[12] used microcolumns of acidic alumina to retain and preconcentrate Cr(VI) and basic alumina to retain and preconcentrate Cr(III) prior to elution into an ICP-AES. Horvath *et al.*^[13] used columns of iminodiacetic acid ethylcellulose to retain Cr(III) and a diethylamine ethylcellulose column to retain Cr(VI) in rain water, the elutions were measured using GF-AAS. Others, have tried to enhance ICP systems by using efficient nebulisation systems, Gjerde *et al.*^[14] used a direct injection nebuliser and Roychowdhury and Koropchak^[15] used a thermospray nebuliser to enhance the coupling of HPLC to ICP-AES. Jakubowski *et al.*^[16] used a hydraulic high pressure nebuliser to increase the sensitivity of HPLC-ICP-MS.

Inorganic tin is relatively non-toxic, while tributyltin is a very effective biocide and is used as an anti-fouling agent for marine structures. However, it has been shown that tributyltin, even at extremely low concentrations seriously affects other marine organisms such as oysters, crabs and fish. Consequently, the determination of tributyltin and dibutyltin, a less toxic degradation product, has become very important. Gas chromatographic methods have been widely utilised, but require derivatisation of the organo-tin compounds, generally using a Grignard reaction to form volatile, stable

compounds. High performance liquid chromatography does not require the preparation of volatile derivatives and has been used directly coupled to AAS and ICP-MS.

Ceulemans *et al.*^[17] used GC-AED to separate organo-tin compounds after preconcentration on a C-18 column. Szpunar-Lobinski *et al.*^[18] used flow injection to preconcentrate organo-tin compounds prior to analysis by GC-microwave induced plasma atomic emission spectrometry. Ebdon *et al.*^[19] used HPLC to separate tin species with UV irradiation to decompose the organo-tin species prior to hydride generation and detection by AAS. Suyani *et al.*^[20] combined HPLC and ICP-MS to speciate and determine organo-tins, while Jewett *et al.*^[21] combined HPLC with GF-AAS.

Interest in selenium in the environment stems from the dual role of selenium as an essential nutrient at low concentrations and as a toxic substance at higher concentrations. Selenium can be present in the environment as selenite (Se IV), selenate (Se VI), elemental selenium (Se⁰), selenide (Se²⁻), dimethylselenide, dimethyldiselenide and dimethyldiselenone. Hydride generation in combination with AAS is the most commonly used technique for selenium species determinations. Selenium hydride is formed essentially only from Se IV. This selectivity for Se IV has resulted in various chemical preparation steps to determine the sum of Se IV and Se VI and the total selenium content of samples. selenium (VI) concentration levels are determined by the difference between the Se IV + Se VI and Se IV determinations. The difference between the Se IV + Se VI and the total selenium concentration determinations gives the concentration of Se⁰ + Se²⁻.

Cutter^[22] used selective hydride generation with AAS to determine selenium species levels in waters. However, Shum and Houk^[23] used a direct injection nebuliser to enhance the sensitivity of ICP-MS to determine selenium species after separation by anion-exchange chromatography. Laborda *et al.*^[24] also used chromatography to separate the selenium species, but off-line, with the fractions being collected and determined by GF-AAS.

The speciation of aluminium in water and in soil, is related primarily to the effects of acid rain. Species of particular concern are Al^{3+} , $\text{Al}(\text{OH})^{2+}$ and $\text{Al}(\text{OH})_4^-$, due to the toxicity of these species to fish and plant life. There has been interest in trying to establish a relationship between aluminium species and toxicity and in developing methods for the determination of aluminium species that would constitute a 'toxic fraction' of the total aluminium concentration.

Both Canizares and Luque de Castro,^[25] and Fairman and Sanz-Medel^[26] have used flow injection analysis (FIA) to determine the various aluminium species. Ion chromatography has been used to determine aluminium species in waters by both Jones and Paull^[27] and Bertsch and Anderson^[28]. Capillary electrophoresis was used to separate the aluminium species prior to u.v. detection by Wu *et al.*^[29].

There is very little information on the environmental species chemistry of antimony, due mainly to the low concentration levels of antimony in the environment. The toxicity and physiological behaviour of antimony depends upon its oxidation state, with Sb III being more biologically active than Sb V. Most analytical procedures utilise the selective hydride generation of Sb III and total antimony with Sb V being calculated by difference. De La Calle Guntinas *et al.*^[30] used selective hydride generation to determine the concentration of each species, while Castillo *et al.*^[31] separated the Sb III and Sb V into organic and inorganic phases, respectively, and generated the hydrides of both species prior to detection by AAS.

Tetra-alkyl lead compounds are emitted into the atmosphere due to their use as gasoline additives. They decompose and form tri-alkyllead, di-alkyllead and inorganic-lead aerosol. These compounds all vary in their degree of toxicity, with the organo-lead species being up to 20 times more toxic than the inorganic lead compounds. The volatile alkyllead compounds are readily separated using gas chromatography.

Lobinski *et al.*^[32] used GC-MIP to determine organo-lead compounds in wine after preconcentration by solvent extraction. Dirkx *et al.*^[33] used cryogenic trapping and GC-GFAAS to determine tetra-alkyllead compounds in dust, while Kim *et al.*^[34] constructed

a transfer line to allow the coupling of GC with ICP-MS to determine alkyllead compounds in fuel. Al-Rashdan *et al.*^[35] coupled HPLC with ICP-MS to allow the speciation of inorganic lead and various organo-lead compounds. A flow injection manifold was used by Borja *et al.*^[36] to perform a determination for total lead and an inorganic lead fraction in samples.

Inorganic mercury is relatively non-toxic in comparison to the organo-mercury compounds. A column of C-18 was used by Aizpun *et al.*^[37] to preconcentrate Hg(II) and MeHg, the eluate was then separated using HPLC, coupled to cold vapour AAS. Emteborg *et al.*^[38] used GC-MIP to determine mercury species levels in natural waters after they were preconcentrated on a dithiocarbamate resin microcolumn and derivatised. Jian and McLeod^[39] used a microcolumn of sulphhydryl cotton fibre to retain organo-mercury from inorganic mercury prior to analysis by CV-AFS.

As can be seen in virtually all of the above studies, the ability to determine individual species levels, which can be much lower than the total level, requires a means of separation and detection with extremely sensitive instruments. The novel “hyphenation” of different techniques to produce a very powerful tools for the analysis of elemental species in the environment will be covered in this thesis.

1.2. Strategies for Chemical Speciation.

Strategies for chemical speciation, therefore, require the hyphenation of a separation technique with a sensitive detection technique. Separation techniques are commonly based on a form of chromatography, while the most commonly used technique for the detection of elements are based on atomic spectroscopy.

1.2.1. Atomic Spectroscopy.

When an atom becomes excited, an electron is promoted from its ground state orbital into an orbital further from the nucleus and with a higher energy level. Such an atom is

said to be in an excited state. An atom is less stable in its excited state and will decay back to the ground state by losing energy through a collision with another particle or by emission of a 'particle' of electromagnetic radiation, known as a photon. As a result of this energy loss, the electron returns to an orbital closer to the nucleus.

If the energy absorbed by an atom is high enough, an electron may be completely dissociated from the atom, leaving an ion of net positive charge. The energy required for this process, known as ionisation, is called the ionisation potential and is different for each element. Ions also have ground and excited states through which they can absorb and emit energy by the same processes as an atom.

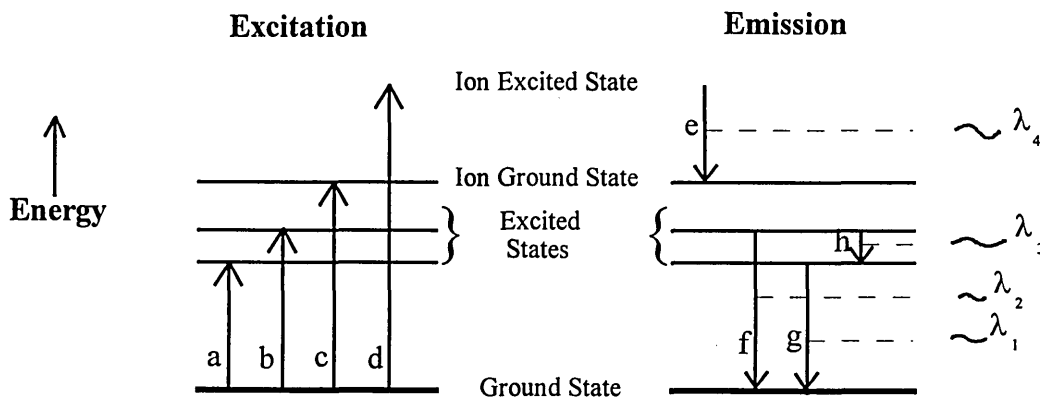

Fig. 1 Energy level diagram depicting energy transitions where a and b represent excitation, c is ionisation, d is ionisation/excitation, e is ion emission, and f, g and h are atom emission.

The difference in energy between the upper and lower energy levels defines the wavelength of the radiation that is involved in that transition. The relationship between this energy difference and wavelength can be derived through Planck's equation, Equation 1.

$$E = h\nu \quad \text{Equation 1}$$

where E is the energy difference between two levels, h is Planck's constant, and ν is the frequency of the radiation. Substituting c/λ for ν , where c is the speed of light and λ is wavelength, we get

$$E = \frac{hc}{\lambda} \quad \text{Equation 2}$$

Equation 2 shows that energy and wavelength are inversely related. Every element has its own characteristic set of energy levels and thus its own unique set of absorption and emission wavelengths. It is this property that makes atomic spectrometry useful for element-specific analytical techniques. A summary of techniques used in trace analysis which are based on atomic spectrometry is given in Table II.

In the atomic spectrometric techniques most commonly used for trace element analysis, the sample is decomposed and atomised by intense heat into a cloud of hot gases containing free elements of interest. Fig. 2 shows the instrumental set-ups for three different techniques used to detect these atoms.

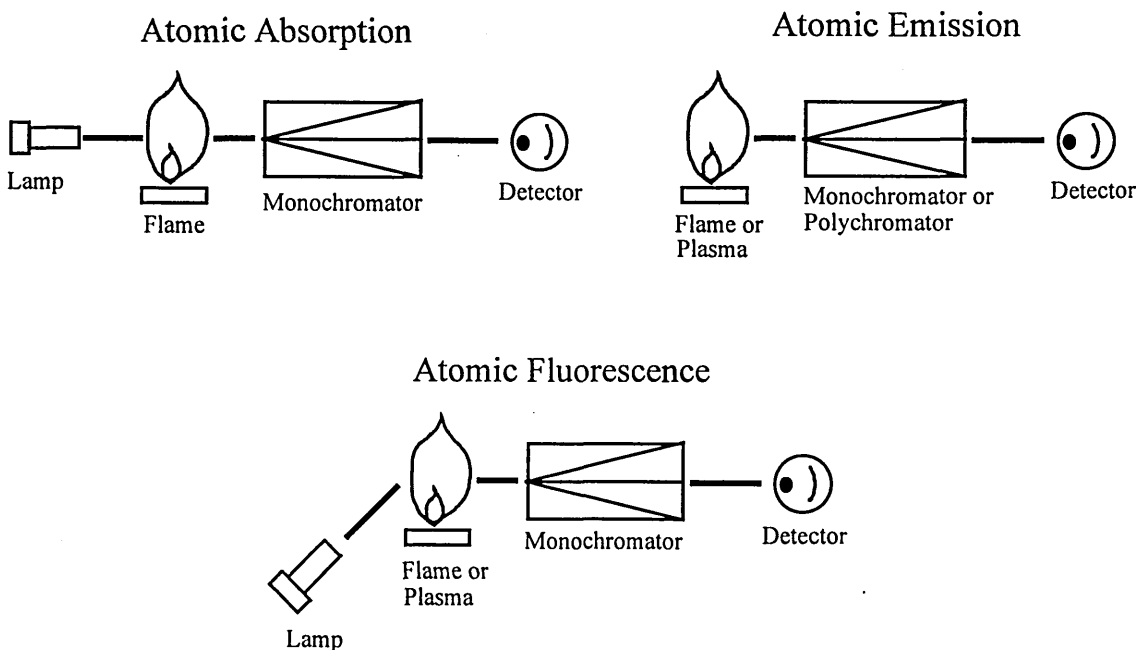

Fig. 2 Atomic spectrometry systems

Spectrometric Technique	Radiation Process	Means of Excitation	Sample Container/Medium	Monochromator	Detector
arc/spark emission	emission	electric arc/spark	carbon or graphite electrode	diffraction grating or prism	photomultiplier or photographic plate
plasma emission	emission	electromagnetic induction	gas plasma	diffraction grating	photomultiplier
atomic absorption	absorption	uv/visible radiation	flame or heated rod/furnace	diffraction grating or prism	photomultiplier
atomic fluorescence	fluorescence emission	uv/visible radiation	flame or heated rod/furnace	filter	photomultiplier
flame atomic emission	emission	flame	flame	diffraction grating, prism or filter	photomultiplier
X-ray fluorescence	fluorescence emission	X-radiation	cell	single crystal diffractor	gas ionisation, crystal scintillation or semiconductor

Table I. Techniques based on atomic spectrometry.

In atomic absorption spectrometry (AAS), light of a wavelength characteristic of the element of interest is passed through the atomic vapour. Some of the light is absorbed by the atoms of the element of interest, the amount of light absorbed is measured and used to determine the concentration of the element.

In atomic emission spectrometry (AES), the sample is subjected to temperatures high enough to cause significant amounts of collisional excitation (and ionisation) to take place. Once the atoms are in an excited state, they decay to lower excitation states emitting light at specific wavelengths. This emitted light is measured and used to determine the concentrations of the elements of interest. One of the most important advantages of AES is the potential to measure more than one element at a time, as more than one element is excited by the high temperatures. This gives us a simultaneous multielement capability.

In atomic fluorescence spectrometry (AFS), a light source such as that used in AAS, is used to excite the atoms of the element of interest. When these excited atoms decay, their emitted radiation is measured and used to determine the concentration of the element of interest, as in AES.

There are three main types of thermal sources used in atomic spectroscopy, these are flames, furnaces and electrical discharges. Lasers have been used as excitation sources, but tend to find uses in other areas of analytical chemistry.

Flames and furnaces, at 3000-4000K, although hot enough to be used to excite many elements for emission spectrometry, tend to be used for atomic absorption spectroscopy as most of the free atoms are present in their ground state.

Electrical discharges, for many years were dominated by ac arcs and dc sparks. More recently, plasmas have been used as atomisation/excitation sources for AES. The electrical plasmas used in analytical atomic spectrometry are highly energetic, ionised gases. These plasma discharges, at 6000K, are much hotter than flames and furnaces. The present state of art in plasma sources for analytical atomic emission spectrometry is

the inductively coupled plasma (ICP). Other plasmas currently being used include the direct current plasma (DCP) and the microwave induced plasma (MIP).

Atomic emission spectrometry has a long history and has been used as an analytical technique for over one hundred years. From early observations by Agricola in the 16th century, through to studies by Bunsen and Kirchoff in the 19th century, to the creation of commercial instruments developed over the last 80 years.

Arc and spark spectroscopy was the best tool available for determining trace concentrations of a wide range of elements. However, sample preparation techniques were difficult and time consuming for many samples. The quality of the data, with precision of 5-10% rsd, was not very good. Matrix effects are often very large and require the use of standards which closely match samples.

While arc/spark emission techniques enjoyed widespread popularity for the determination of metals, flame emission spectrometry was used for the determination of the alkalis and other easily excited elements. While the atomic spectra emitted by flames is simpler than that emitted from arcs and sparks, the main limitation of flames is that they are not hot enough to cause emission for many elements.

In the 1960's and 1970's both flame and arc/spark atomic emission spectrometry declined in popularity. Atomic absorption spectrometry began to dominate the area of trace element analysis. Since the absorption of light by atoms in their ground state was the mode of detection, the need for very high temperatures was no longer a limitation.

At its height, flame atomic absorption spectrometry, was used exclusively in the analysis of solutions for trace metals. Flame atomic absorption offers the analyst high precision and moderate detection limits. Electrothermal atomisation (graphite furnace) atomic absorption spectrometry offers high sensitivity and low detection limits.

Both the flame and graphite furnace AAS techniques are used today and provide an excellent means of performing trace elemental analysis. However, AAS instruments are limited in that they tend to be able to analyse only one element at a time. Also, the poor

dynamic range of AAS techniques, tends to require greater dilution than atomic emission techniques.

Stanley Greenfield of Birmingham, England is credited with the first published report (1964) on the use of an atmospheric pressure inductively coupled plasma (ICP) for elemental analysis via atomic emission spectrometry (AES)^[40]. Along with Greenfield, Velmer Fassel and his colleagues at Iowa State University are generally credited with the early refinements of the technique allowing the analysis of nebulised solutions. By 1973, the low detection limits, freedom from interferences, and a long linear working range proved that the ICP was clearly a superior emission source to those previously used. The ICP is now the established emission source for trace elemental analysis instrumentation^[41].

To obtain the plasma source, a stream of argon gas is directed through a torch of concentric quartz tubes. A water-cooled copper coil, called the load coil, surrounds the top of the torch and is connected to a radio frequency (RF) generator. The RF sets up electric and magnetic fields around the top of the torch. A seed of electrons is provided by a tesla coil, which are then caught up in the magnetic and electric fields and accelerated by them, this is known as inductive coupling. These high energy electrons then collide with argon atoms, stripping off more electrons. This collisional ionisation of the argon atoms continues in a chain reaction, forming a plasma consisting of argon atoms, electrons and argon ions. This is known as an inductively coupled plasma (ICP) discharge, see Fig. 3.

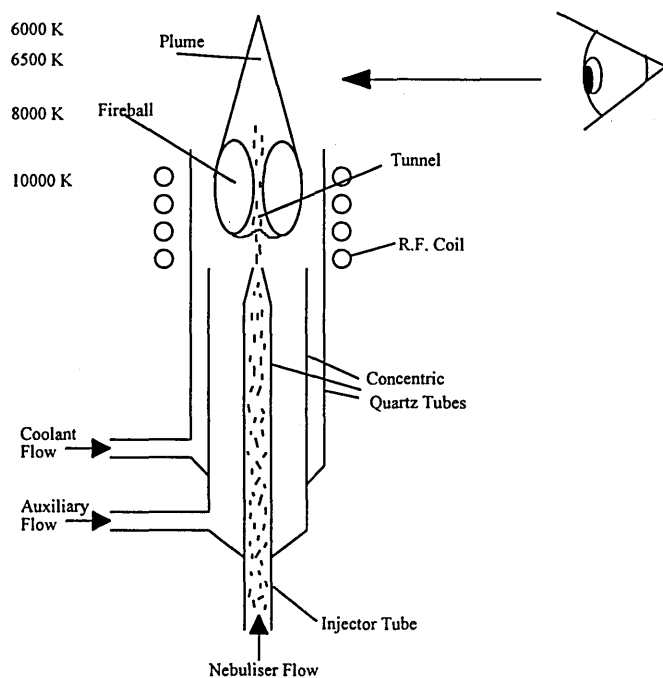

Fig. 3. ICP torch with Plasma source.

The liquid sample is converted into a very fine mist of aerosol droplets generally via a nebulisation device, and are then introduced into the plasma core. The plasma then performs several processes to allow the emission of characteristic radiation from the analyte. Firstly the removal of solvent (usually water) from the analyte, this process is known as desolvation. Secondly the solid analyte is then vaporised to a gas. Thirdly, the analyte molecules are then dissociated into atoms and these atoms are then excited or ionised. For an atom or ion to emit its characteristic radiation, one of its electrons must be promoted to a higher energy level through an excitation process. The analytical advantages of the ICP over other emission sources are derived from its ability to vaporise, atomise, excite, and ionise efficiently. The processes that take place in the plasma are depicted in Fig. 4.

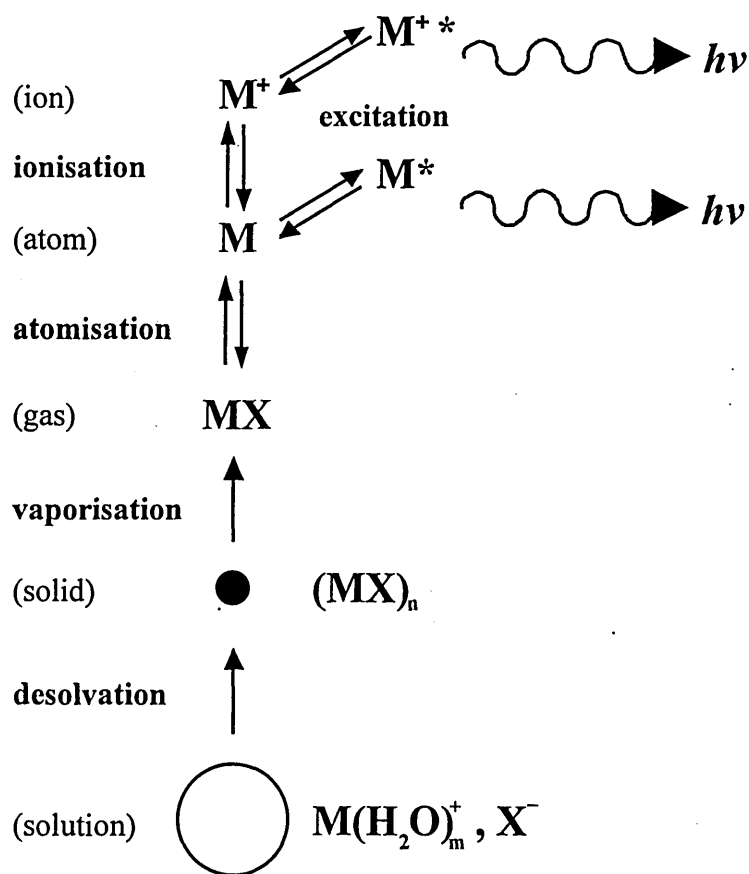

Fig. 4. Processes which occur in the Plasma discharge.

The ICP has a relatively long sample residence time at high temperature and so gives very efficient sample volatilisation, dissociation, and excitation. This gives the ICP considerable powers of detection, which provide solution detection limits at levels

between 1 ng/ml and 1 μ g/ml for most elements. The ICP also offers the analyst very simple sample preparation and introduction methods and high sample throughput rates of 1 sample per minute.

The ICP owes many of its advantages of being an emission source to the very efficient excitation of analyte ionic species within the plasma. The ions formed by the plasma are present at high concentrations and tend to be singly charged, positive ions. This indicated the possibility of the ICP to being an atmospheric pressure ion source for mass spectrometry. In the early 1980's Gray in the UK, Houk in the USA and Douglas in

Canada interfaced an ICP with a quadrupole mass spectrometer, which led to the development of commercial instruments^[42-47] with detection limits at 5-0.01 ng/ml^[48] levels. However, in ICP spectrometry, the sample spends a relatively long time in a high temperature environment, hence speciation information in the sample would therefore be lost. It is therefore necessary to separate the species before they reach the high temperature plasma.

1.2.2. Separation Techniques.

A form of separation is therefore required in order to obtain species information. This separation procedure normally involves a form of chromatography. The word chromatography was first used in 1903 by Tswett^[49] to describe the separation of plant pigments by percolating a petroleum-ether extract through a glass column packed with powdered calcium carbonate. There are many forms of chromatography in use today, e.g.

Thin layer chromatography

Ion chromatography

Gas chromatography

High Performance Liquid Chromatography

etc.

All the techniques depend upon the same basic principle, i.e. variation in the rate at which different components of a mixture migrate through a stationary phase under the influence of a mobile phase. During a chromatographic process, solute molecules are continuously moving back and forth between the stationary and mobile phases. While they are in the mobile phase, they are carried forward with it but remain virtually stationary during the time they spend in the stationary phase. The rate of migration of each solute is therefore determined by the proportion of time it spends in the mobile phase.

Thin layer chromatography involves the separation of mixtures in microgram quantities by movement of a solvent across a flat surface. The components migrate at different rates due to differences in solubility, adsorption, size or charge. Elution is halted before the solvent front reaches the opposite side of the surface and the components examined *in situ* or removed for further analysis. The stationary phase is usually a thin layer of cellulose, silica gel, alumina, ion-exchange or gel permeation material supported on glass plates or aluminium foil.

Ion chromatography, using a conductivity detector, requires two columns. The first column separates the analytes while the second (suppressor) column suppresses the eluent electrolyte by converting its ions to water. For anions, the separation column is generally packed with pellicular strong anion exchange resin in hydrogen carbonate form.

Gas chromatography, so called because the mobile phase is a gas, comprises gas-liquid chromatography (GLC) and gas-solid chromatography (GSC). For GLC the stationary phase is a high-boiling liquid and the sorption process is predominantly one of partition. For GSC the stationary phase is a solid and adsorption plays the major role. Components, which must be volatile and thermally stable at the operating temperature, migrate at different rates due to differences in boiling point, solubility or adsorption.

In high performance liquid chromatography, mixtures in microgram quantities are separated by passage of the sample through a column containing a stationary solid by means of a pressurised flow of a liquid mobile phase. Components migrate through the column at different rates due to differences in solubility, adsorption, size or charge. In normal phase operation, the stationary phase is generally silica or alumina, and the eluent is a volatile non-polar solvent. In reversed-phase operation, the stationary phase is a non-polar material and the eluent is a polar solvent.

Electrophoresis is the separation of charged materials by differential migration across a surface or through a column in an applied potential gradient. Migration rates depend on size, shape and charge of species. Paper, cellulose acetate or polymeric gels are used as

supporting mediums for the electrolyte solution. Application of a d.c. potential across the solution for a fixed period of time results in the components of a mixture, originally placed at the centre, separating into individual bands or spots. Detection techniques such as spraying with a chromatogenic reagent or staining with a dyestuff are then used to visualise the developed electrophoretogram. This technique differs from chromatography in that only a single phase is involved, i.e. the electrolyte solution which essentially remains stationary on the supporting medium.

Traditional separation techniques such as solvent extraction and column chromatography can be performed off-line, the fractions collected being analysed independently to give the concentrations of the separated species. Solvent extraction can also be used to preconcentrate analytes by extracting a large volume of sample into a smaller volume and back extracting. These techniques however, greatly increase the analysis time of each sample.

Modern hyphenated techniques based on combinations of high performance liquid chromatography (HPLC) or gas chromatography (GC) with ICP are powerful combinations for performing speciation studies. To be successful, gas chromatographic separations require that the species be volatile and thermally stable under the temperature programmes designed for the analysis. This often means that derivatives of the analytes must be prepared prior to separation. Liquid chromatography is more amenable to separation of non-volatile compounds, particularly those of high molecular weight, provided that suitable column packing and eluents compatible with sample components can be found. Many improvements in speciation analyses have been achieved by coupling a gas or liquid chromatograph to a spectrometric detector.

The use of an ICP as a detector for GC was first reported in the late 1970's. Sommer and Ohls used a GC-ICP technique for the determination of tetraalkyllead^[50] compounds and nickel and zinc diethyldithiocarbamates^[51]. Fry *et al.*^[52] utilised the fluorine atomic emission lines for the selective detection of various fluorine-containing organic compounds. Despite these early studies, the ICP has never been widely adapted as a GC

detector and there have been very few papers on the subject since the early 1980's. This is in marked contrast to the use of the microwave induced plasmas for GC analysis^[53]. Although the ICP can withstand organic solvents more readily than the MIP and does not require the addition of oxygen and nitrogen to reduce deposits, these advantages are far outweighed by the fact that the sensitivities for non-metals are much inferior to those using an MIP.

The technique of HPLC-ICP has however found more widespread use due to the compatibility of liquid carrier used in HPLC with the common introduction systems of ICPs. When used as a detector for HPLC, the ICP offers good sensitivity, a wide dynamic range and multi-element detection capabilities. The conventional coupling of HPLC to ICP, where the end of the column is connected to the nebuliser, results in poor detection limits due to the ineffective conversion of effluent flow into aerosol and its transport to the plasma. Such couplings also demonstrate the poor tolerance of the ICP for common mobile phases used in HPLC. The poor detection limits obtained for many elements have been of marginal use for element speciation at levels of environmental significance. Current developments suggest that substantial enhancements in working sensitivities are occurring. A promising development is the direct injection nebuliser (DIN)^[54], a total injection microconcentric nebuliser which gives close to 100% nebulisation and transport efficiency. The use of HPLC-ICP with DIN has been effective for the determination and speciation of metalloids and has been used for the speciation of arsenic^[55].

1.2.3. Flow Injection.

Flow injection^[56] is a versatile sample processing technique that permits rapid on-line separation of species. The term flow injection was recently described by Fang^[57] as “a non-chromatographic flow analysis technique for quantitative analysis, performed by reproducibly manipulating sample and reagent zones in a flow stream under thermodynamically non-equilibrated conditions”. The technique was invented by

Ruzika and Hansen, and had a dramatic effect on analytical chemistry. The simplest single line FI system (see Fig. 5) consists of thin bore, chemically resistant tubing, connecting a reservoir of carrier with a flow-through detector. The carrier stream is propelled through the tubing by means of a peristaltic pump (piston pumps or gas pressure have also been used). A well defined volume of sample is injected into the carrier stream by means of a valve. From the point of injection, the sample plug moves along the tubing and disperses on its way to the detector. The detector senses the concentration gradient, formed by the dispersion of the sample and carrier as a transient signal, (a peak).

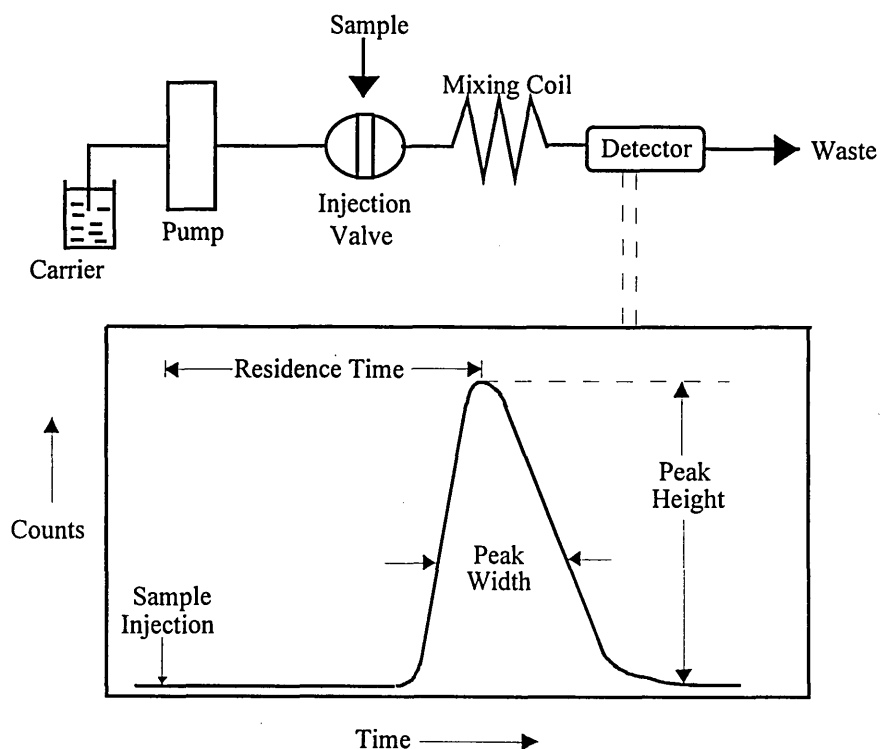

Fig. 5. Schematic diagram of a single line FIA manifold with corresponding FIA peak.

Greenfield^[58] gave a detailed account of the advantages of the use of transient signals achieved in FIA. The wash-in/wash-out time of a steady state signal was 45 seconds compared to a wash-in/wash-out time of 33 seconds for a peak of slightly less than steady-state magnitude. Also, as the next sample can be injected before the previous sample has returned to baseline the sample turnaround time can be reduced even further.

Chemical processes such as dilution, standard addition, preconcentration, reduction, oxidation, solvent extraction, separation and the removal of interferences can be carried out on-line as indicated in Fig. 6.

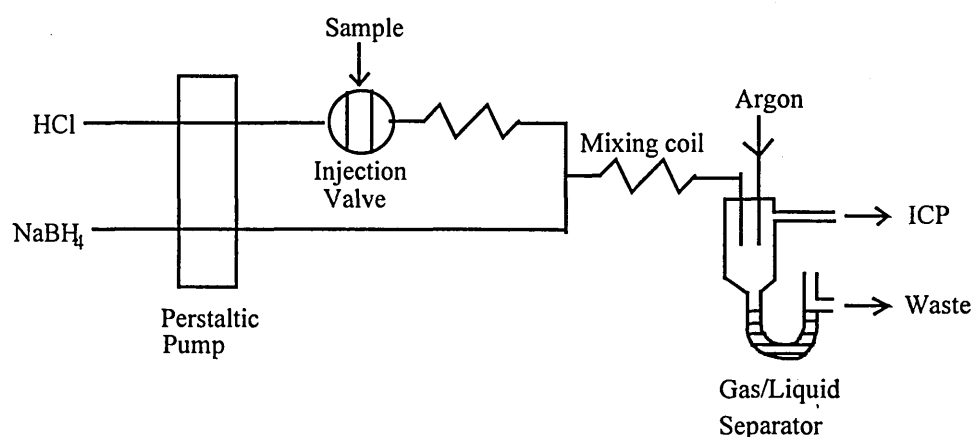
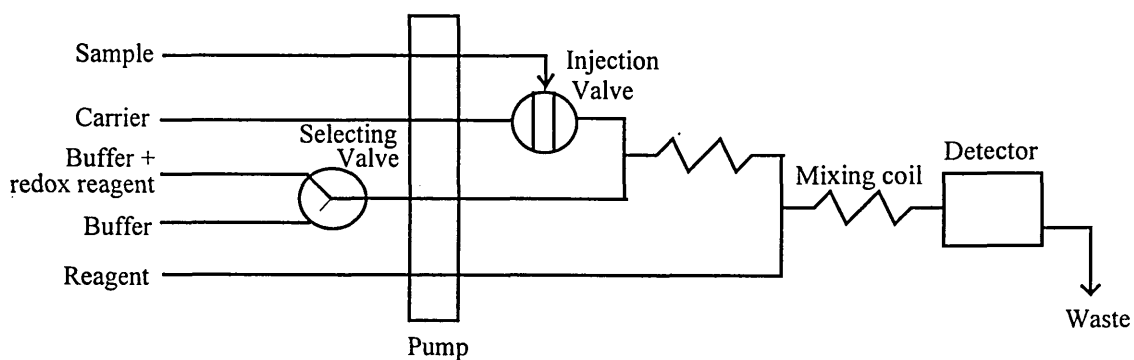
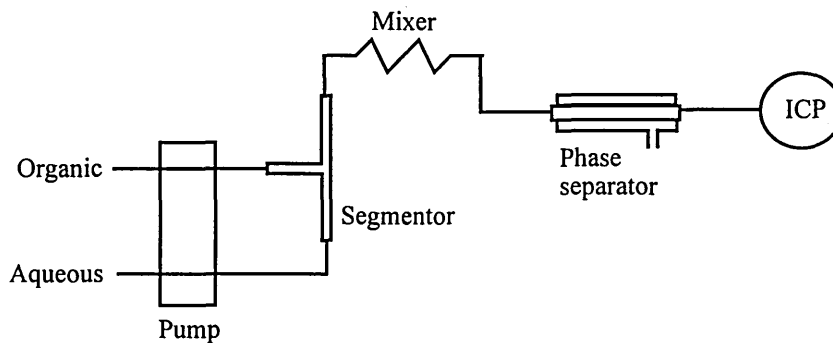

Fig. 6 (a) FI manifold to perform hydride generation^[59].



(b) FI manifold to perform redox reactions^[60].



(c) FI manifold to perform solvent extraction^[61].

Manifold (a) is used for selective hydride generation of elemental species such as selenium; only selenium(IV) undergoes hydride generation and hence, this manifold can be used as a means for speciating Se(IV) from Se(VI). Manifold (b) utilises a redox reagent which can be switched on or off and allows the sequential determination of the oxidation states of an element. Manifold (c) uses on-line solvent extraction to permit determination of the organic and inorganic forms of an element present in a sample.

An extremely powerful use of flow injection methodologies is in combination with microcolumns of various resins. Microcolumns are capable of performing a wide range of analytical techniques, such as, preconcentration, separations and matrix removal.

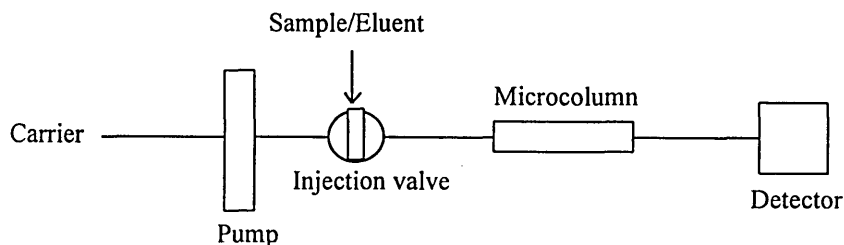

(d) Flow injection manifold incorporating a microcolumn

Flow injection ICP-AES suffers in the same way as HPLC-ICP-AES in that the conversion of the carrier flow into aerosol is very poor. That is, most samples generally have to be introduced to the ICP in liquid form and the main interface for introducing liquids to an ICP is pneumatic nebulisation. This is where the sample, via a peristaltic pump is introduced, generally, to either a concentric, V-groove or cross flow nebuliser attached to a spray chamber where a gas/liquid aerosol is formed. Pneumatic nebulisers use a high speed gas flow to break up a liquid to create an aerosol. This process is known as nebulisation and is one of if not the most critical steps in ICP spectrometry. Because only small droplets are useful in the ICP, the ability to produce small droplets for a wide variety of samples largely determines the utility of a nebuliser for ICP-AES. Sample introduction has been described as the Achilles' heel of atomic spectroscopy^[62].

In concentric nebulisers, the solution is introduced through a capillary tube to a low pressure region created by a gas flowing rapidly past the end of the capillary. The low pressure and high-speed gas combine to break up the solution into an aerosol. However, the small orifices of concentric nebulisers make them prone to blockages.

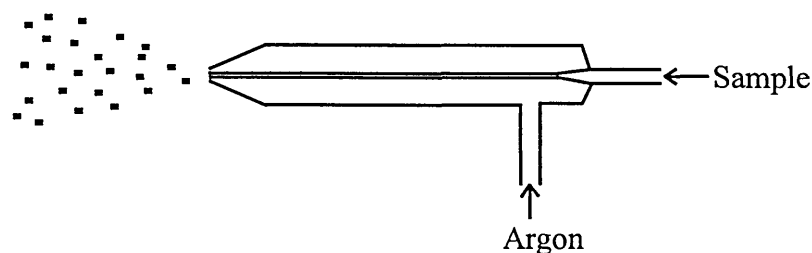

Fig. 10. Concentric (Meinhard) nebuliser

Cross-flow nebulisers^[63], in which a high speed stream of gas is directed perpendicular to the tip of the sample capillary tube, are less prone to blockages. Cross-flow nebulisers are generally not as efficient as concentric nebulisers at creating the small droplets

needed for ICP analyses. However, they are generally more rugged and corrosion resistant than glass concentric nebulisers.

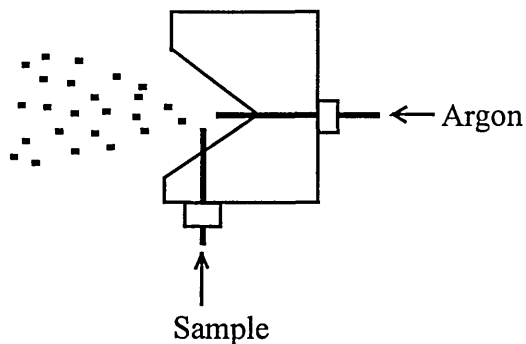

Fig. 11. Cross-flow Nebuliser

The third type of pneumatic nebuliser used for ICP-AES is the V-groove nebuliser^[64]. The sample flows down a groove which has a small hole in the centre of it. High speed gas emanating from the hole shears the sheet of liquid into small drops. This nebuliser is the least susceptible to clogging and is used to nebulise very viscous liquids.

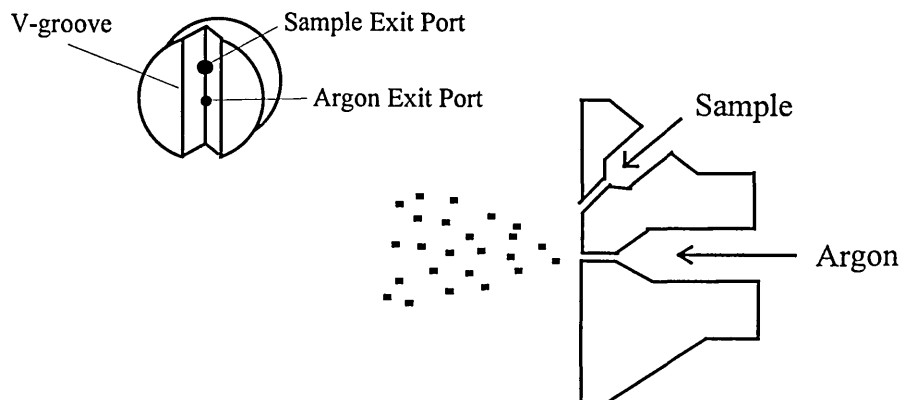

Fig. 12. V-groove nebuliser

However, in all these systems, the nebulisation process is very inefficient and only about 1-3% of the sample reaches the plasma. The benefits from achieving an improved sample introduction efficiency are clear.

Several alternatives to pneumatic nebulisers with spray chambers have been proposed as sample introduction systems for ICP spectrometry. One approach for improved sample nebulisation efficiency is the use of ultrasonic nebulisation^[65]. Ultrasonic nebulisers use high-frequency ($\sim 1.3\text{MHz}$) mechanical waves to generate an aerosol very efficiently. The nebulisation efficiency is so great that a desolvation unit must be added to remove the solvent from the sample to prevent overloading the plasma^[66]. Even though ultrasonic nebulisers can give the best sensitivity for ICP-AES they are not routinely used^[67].

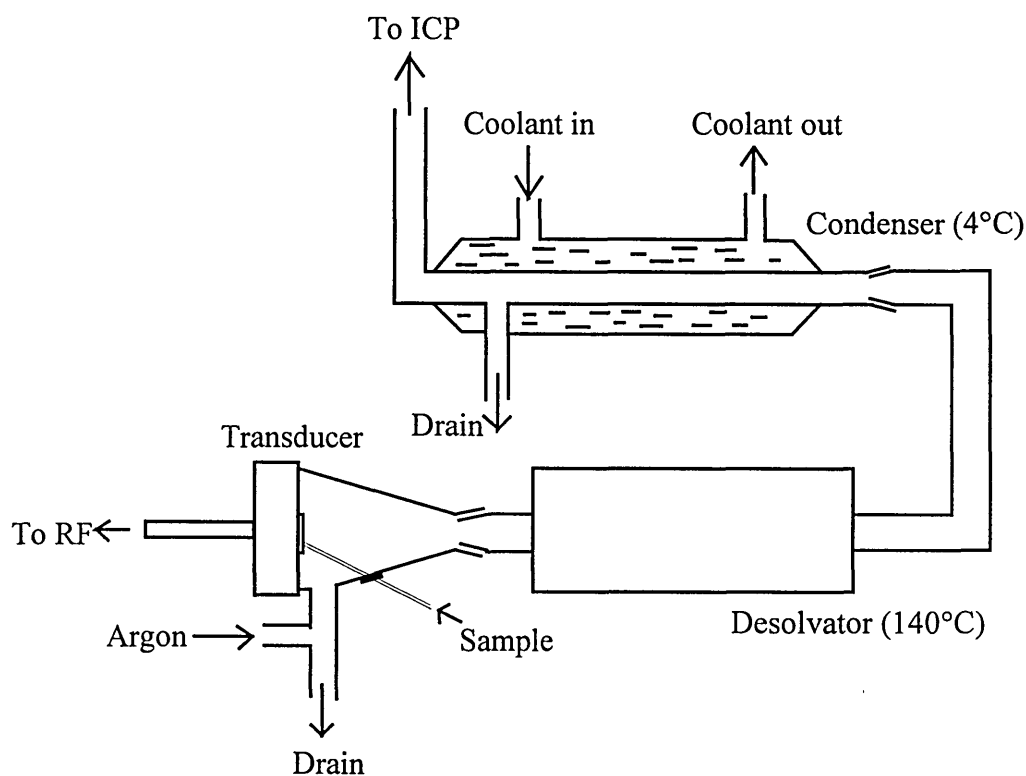

Fig. 13. Ultrasonic Nebulisation set-up.

One of the most widely used alternative sample introduction to pneumatic nebulisation is hydride generation^[68]. The sample, in dilute acid, is mixed with a reducing agent,

generally a solution of sodium borohydride in dilute sodium hydroxide. The reaction of the sodium borohydride with the acid produces hydrogen. The hydrogen reacts with the Hg, Sb, As, Bi, Ge, Pb, Se, Te and Sn in the sample to form volatile hydrides of these elements. These gaseous compounds are separated from the rest of the reaction mixture and transported to the plasma. Improvements in detection limits by a factor of up to 1000^[69] have been reported for the above elements. However, hydride generation is very prone to interferences and generally requires the elements to be in a specific oxidation state.

Another technique, direct injection nebulisation^[70], involves injecting a liquid sample directly into the plasma using a torch that has a nebuliser like nozzle at the tip of the injector. This technique is most successful when used for element specific detection of liquid chromatography effluents. The main advantages of the direct injection technique are that the sample transport efficiency to the plasma is 100% and very small samples can be analysed. All of these introduction systems, however, require the sample to be in liquid form. There is however a requirement to be able to introduce solid samples to the ICP, to obtain species information.

1.2.4. Separation in the Solid State

There is also interest in performing *in situ* speciation in the solid state, e.g. element speciation in atmospheric aerosols. Digestion procedures on solid samples, to produce liquid samples, are often very harsh and often destroy the natural speciation states. There are three main techniques for introducing solid samples to ICP systems, laser ablation (LA)^[72,73], arc/spark sources^[74,75] and electrothermal vaporisation (ETV)^[76,77].

Laser ablation techniques, in which a high powered laser is used to vaporise a small portion of a sample, which is then transported in a stream of argon to the ICP, find uses in geological analysis. This is because of the very localised sampling of the laser. However, because of the destructive nature of laser ablation, it does not generally find use in the determination of species data. As already stated though, thin layer

chromatography and electrophoresis, separate components on a solid medium. These components then have to be removed, before further quantitative analysis can be carried out. Laser ablation, because of its very localised sampling, gives us the opportunity to analyse these separated component *in-situ*. This would greatly speed up analysis times.

Electrothermal vaporisation is much easier to perform than electrothermal atomisation, this is because the aim of the procedure is not to produce atoms, but to produce molecular species. This means that the atomisation step in ETA is not as critical as for ETV. Since the aim of ETV is to produce molecular species, this form of sample introduction could be utilised for speciation work. Electrothermal vaporisation greatly increases the efficiency of sample introduction, with approximately 50-80% of the sample reaching the plasma. By carefully controlling the ETV parameters it is possible to vaporise the different species of an element selectively. It would however be easier if all the species of an element were vaporised at a similar time and the detector could measure the different molecular species, for this a mass spectrometer could be utilised.

There are three main types of mass spectrometer, quadrupole based systems, magnetic sector based and time-of-flight mass spectrometers. The time-of-flight mass spectrometer (ToF-MS) offers many advantages over the other two, one of which is simultaneous detection of all masses. Time-of-flight mass spectrometry^[78] transports virtually 100% of the ions and detects them all on a simultaneous basis. This compares to the sequential detection of the quadrupole mass spectrometers generally used in ICP-MS, which results in a loss in sensitivity of $1/n$ where n = number of masses of interest.

	Quadrupole	Magnetic sector	Time-of-flight
Resolution	10^2 - 10^3	10^4	$>10^3$
Mass range	$\sim 10^3$	$>10^4$	infinity
Transmission	0.01-0.1	0.1-0.5	0.5-1.0
Mass Detection	sequential	sequential	parallel
Relative sensitivity	1	10	10^4

Table III Comparison of the different mass spectrometers

Advantages of ToF-MS

1. Complete mass spectrum for each ionisation event - spectra can be obtained for very small amounts of sample (approaching attomole).
2. Ideal where ionisation is pulsed or spatially confined.
3. High transmission
4. Unlimited mass range.
5. Fastest scanning mass spectrometer; repetition rates up to 100 kHz.
6. Performance dependant on electronics rather than mechanical alignment.

The principle behind Time-of-Flight Mass Spectrometry (ToF-MS) is that if a packet of ions of differing mass/charge, (m/z), ratios are acted upon by the same electric impulse and are rapidly accelerated through a constant energy electric field, K , then they will acquire individual velocities, u , inversely proportional to the square root of their m/z ratios:

$$u = \left\langle \frac{2zK}{m} \right\rangle^{1/2} \quad \text{Equation 3}$$

If the ions are then caused to traverse a fixed distance, l , to the detector, then they separate in time according to their m/z ratios, the lightest ions having the highest velocities reaching the detector first and vice-versa.

$$T. o. F. = \left\langle \frac{l}{u} \right\rangle = \left\langle \frac{m}{2Kz} \right\rangle^{\frac{1}{2}} l = \left\langle \frac{l^2}{2K} \right\rangle^{\frac{1}{2}} \left\langle \frac{m}{z} \right\rangle^{\frac{1}{2}} \quad \text{Equation 4}$$

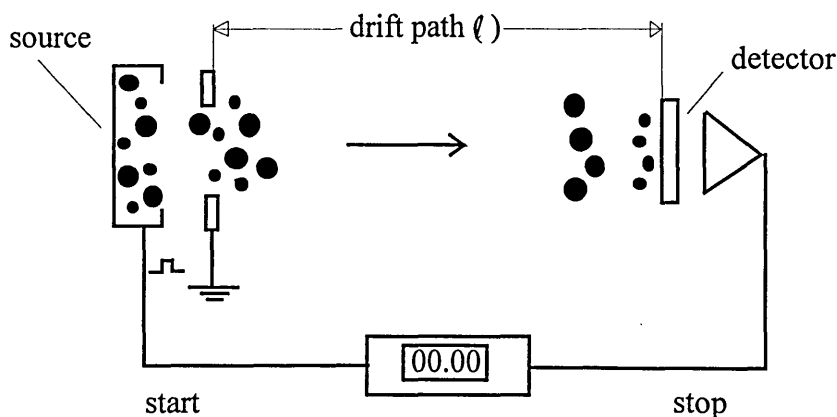

Fig. 14. Schematic of basic time of flight mass spectrometer.

The first instance of a velocity filter being employed was the determination of the velocity of cathode rays by Wiechert (1899). The first ToF instruments were built in the late 1940's and the resolving power has slowly increased from below 100 to above 10000^[79] as the electronic methods of the pulse techniques have improved.

There has recently been an increase in interest in ToF due to the development of new ionisation techniques such as plasma and laser desorption. As a result, ToF-MS is now beginning to make a significant impact on the world of mass spectrometry. This is because of its unique advantages of being capable of providing a complete mass spectrum per event combined with unlimited mass range.

An instrument based on the combination of ETV, allowing the vaporisation of all molecular species and a ToF-MS which will also allow controlled dissociation of the sample via an electron impact ion source in the mass spectrometer, would be a new hybrid system which would offer extreme detection sensitivity on a simultaneous basis. In addition, it could offer element speciation capability for direct measurement in the solid state.

1.3. Conclusions.

The field of chemical speciation is growing rapidly, the greater the understanding of speciation in the environment, the greater the need becomes to understand more. Modern techniques, such as inductively coupled plasma atomic emission spectrometry and inductively coupled plasma mass spectrometry, allow the determination of trace element concentrations, at levels of environmental significance. However, the analysis of the various elemental species present, which can be much lower than the total element concentration, requires a considerable enhancement in sensitivity. Therefore, to determine element species at levels which they occur in the environment, requires either sample preconcentration or an improvement in the sample introduction efficiency of atomic spectroscopy. Also, as species exist in a dynamic equilibrium in a sample, it is necessary that procedures developed to analyse species are capable of being performed rapidly, to minimise any species interconversion or that species are collected and stored in a stable form.

Chemical speciation data is currently impossible to obtain from solid samples, typical sampling procedures generally destroy the natural species. New techniques are required which will allow the direct analysis of solids to obtain both total elemental and species concentrations in a sample.

1.4. Aims and Objectives of This Work.

The aim of this research is to further the understanding of speciation analysis through the study of new strategies and techniques. The objectives are to create rapid and simple techniques to perform speciation on both liquid and solid samples.

The main area of research is to extend the capability of atomic spectroscopy to perform speciation studies by combining developments in sample introduction with sample presentation procedures. Specifically, novel flow injection manifolds are to be designed to perform on-line chemical reactions to allow the separation and preconcentration of selenium(IV) and selenium(VI). The flow injection manifolds will be combined with

alternate nebulisation systems, to permit speciation measurements of selenium at naturally occurring concentrations. Microcolumns of various materials will be the main media for preconcentrating and separating these selenium species.

A further area of research will be an assessment on the potential use of laser ablation to determine cobalt-protein components separated by electrophoresis. The current state of the art, autoradiography, requires the use of radioactive Co-57, followed by two weeks of radiotracer experiments to observe where cobalt-protein components are present. The use of laser ablation coupled to ICP mass spectrometry to map the cobalt concentration across an electrophoresis plate, will hopefully remove the requirement to use radioactive materials and dramatically speed up analysis times. The assessment will cover the detection and resolution capabilities of the system.

A further area of research work will be to assess and characterise the potential of the novel electrothermal vaporisation - time of flight - mass spectrometer, under development at the research labs of SpectroAnalytical, in Kleve, Germany, for determining species in the solid state.

1.5. References

- [1] A. M. Ure, P. Quevauviller, H. Muntau and B. Griepink, *Int. J. Environ. Anal. Chem.*, 1993, **51**, 135.
- [2] A. M. Ure, P. Quevauviller, H. Muntau and B. Griepink, EUR Report 14763 EN, Commission of the European Communities, Luxemborg, 1993.
- [3] K. Schwarz, *Clinical Chemistry and Chemical Toxicology of Metals*, S. S. Brown (ed.), Elsevier, New York, 1978.
- [4] X. E. Le, W. R. Cullen and K. J. Reimer, *Talanta*, 1994, **41**, 495.
- [5] N. Violante, F. Petrucci, F. LaTorre and S. Caroli, *Spectroscopy (Eugene, Oreg.)*, 1992, **7**, 36.
- [6] R. Rubio, A. Padro, J. Alberti and G. Rauret, *Anal. Chim. Acta*, 1993, **283**, 160.
- [7] S. Branch, L. Ebdon and P. O'Neil, *J. Anal. At. Spectrom.*, 1994, **9**, 33.
- [8] E. Russeva, I. Havezov and A. Detcheva, *Fres' J. Anal. Chem.*, 1993, **347**, 320.
- [9] H. B. Han, Y. B. Liu, S. F. Mou and Z. M. Ni, *J. Anal. At. Spectrom.*, 1993, **8**, 1085.
- [10] W. M. Mertz, *Physiol. Rev.*, 1969, **49**, 163.
- [11] S. De Flora, M. Bagnasco, D. Serra and P. Zanicchi, *Mutation Research*, 1990, **19**, 238.
- [12] A. G. Cox and C. W. McLeod, *Mikrochim. Acta*, 1992, **109**, 161.
- [13] Z. Horvath, A. Lasztity, I. Varga, E. Meszaros and A. Molnar, *Talanta*, 1994, **41**, 1165.
- [14] D. T. Gjerde, D. R. Wiederin, F. G. Smith and B. M. Mattson, *J. Chromatogr.*, 1993, **640**, 73.
- [15] S. B. Roychowdhury and J. A. Koropchak, *Anal. Chem.*, 1990, **62**, 484.
- [16] N. Jakubowski, B. Jepkens, D. Stuewer and H. Berndt, *J. Anal. At. Spectrom.*, 1994, **9**, 193.
- [17] M. Ceulemans, J. Szpunar-Lobinski, W. M. R. Dirkx, R. Lobinski and F. C. Adams, *Int. J. Environ. Anal. Chem.*, 1993, **52**, 113.
- [18] J. Szpunar-Lobinski, M. Ceulemans, R. Lobinski and F. C. Adams, *Anal. Chim. Acta.*, 1993, **278**, 99.
- [19] L. Ebdon, S. J. Hill and P. Jones, *Talanta*, 1991, **38**, 607.

- [20] H. Suyani, D. Heitkemper, J. Creed and J. Caruso, *Appl. Spectrosc.*, 1989, **43**, 962.
- [21] K. L. Jewett and F. E. Brinckman, *J. Chromatogr. Sci.*, 1981, **19**, 583.
- [22] G. A. Cutter, *Electr. Power Res. Inst.*, (Rep.) EPRI EA (Palo Alto, Calif.), EPRI EA 4642, 1986, pp. 79.
- [23] S. C. K. Shum and R. S. Houk, *Anal. Chem.*, 1993, **65**, 2972.
- [24] F. Laborda, D. Chakraborti, J. M. Mir and J. R. Castillo, *J. Anal. At. Spectrom.*, 1993, **8**, 643.
- [25] P. Canizares and M. D. Luque de Castro, *Anal. Chim. Acta*, 1994, **1-2**, 59.
- [26] B. Fairman and A. Sanz-Medel, *Int. J. Environ. Anal. Chem.*, 1993, **50**, 161.
- [27] P. Jones and B. Paull, *Anal. Proc.*, 1992, **29**, 402.
- [28] P. M. Bertsch and M. A. Anderson, *Anal. Chem.*, 1989, **61**, 535.
- [29] N. Wu, W. J. Horvath, P. Sun and C. W. Huie, *J. Chromatogr.*, 1993, **635**, 307.
- [30] M. B. De La Calle Guntinas, Y. Madrid and C. Camara, *Fres'. J. Anal. Chem.*, 1992, **343**, 597.
- [31] J. R. Castillo, C. Martinez, P. Chamorro and J. M. Mir, *Mikrochim. Acta*, 1986, **1-2**, 95.
- [32] R. Lobinski, J. Szpunar-Lobinski, F. C. Adams, P. L. Teissedre and J. C. Cabanis, *J. AOAC Int.*, 1993, **76**, 1262.
- [33] W. M. R. Dirkx, R. J. A. Van Cleuvenbergen and F. C. Adams, *Mikrochim. Acta*, 1992, **109**, 133.
- [34] A. W. Kim, M. E. Foulkes, L. Ebdon, S. J. Hill, R. L. Patience, A. G. Barwise and S. J. Rowland, *J. Anal. At. Spectrom.*, 1992, **7**, 1147.
- [35] A. Al Rashdan, N. P. Vela, J. A. Caruso and D. T. Heitkemper, *J. Anal. At. Spectrom.*, 1992, **7**, 551.
- [36] R. Borja, M. De La Guardia, A. Salvador, J. L. Burguera and M. Burguera, *Fres'. J. Anal. Chem.*, 1990, **338**, 9.
- [37] B. Aizpun, M. L. Fernandez, E. Blanco and A. Sanz-Medel, *J. Anal. At. Spectrom.*, 1994, **9**, 1279.
- [38] H. Emteborg, D. C. Baxter and W. French, *Analyst (London)*, 1993, **118**, 1007.
- [39] W. Jian and C. W. McLeod, *Anal. Proc. (London)*, 1991, **28**, 293.
- [40] S. Greenfield, I. L. I. Jones and C. T. Berry, *Analyst*, 1964, **89**, 713.

- [41] A. Montaser and D. W. Golightly, in *Inductively Coupled Plasmas in Analytical Spectrometry*, A. Montaser and D. W. Golightly, Ed., VCH Publishers, New York, 1987, pp. 1-15.
- [42] R. S. Houk, V. A. Fassel, G. D. Flesch, H. J. Svec, A. L. Gray and C. E. Taylor, *Anal. Chem.*, 1980, **52**, 2283.
- [43] A. R. Date and A. L. Gray, *Analyst*, 1981, **106**, 1255.
- [44] D. J. Douglas, G. Rosenblatt and E. S. K. Quan, *Trace Subst. Environ. Health*, 1983, **17**, 385.
- [45] A. L. Gray, *Spectrochim. Acta*, 1985, **40B**, 1525.
- [46] A. L. Gray, *J. Anal. At. Spectrom.*, 1986, **1**, 403.
- [47] A. L. Gray, in *Applications of Inductively Coupled Plasma Mass Spectrometry*, eds. A. R. Date and A. L. Gray, A. L. Blackie, Glasgow, pp. 1-42.
- [48] A. L. Gray, in *Inorganic Mass Spectrometry*, Chemical Analysis Vol. 95, ed. Adams, pp. 257-300, Wiley, New York, 1988.
- [49] M. Tswett, *Warsaw Soc. Nat. Sci., Biol. Sec.*, 1903, **14**, No. 6.
- [50] D. Sommer and K. Ohls, *Fres. Z. Anal. Chem.*, 1979, **95**, 37.
- [51] K. Ohls and D. Sommer, in *Developments in Atomic Plasma Spectrochemical Analysis*, ed. R. M. Barnes, Heyden, London, 1981, pp. 321-326.
- [52] R. C. Fry, S. J. Northway, R. M. Brown and S. K. Hughes, *Anal. Chem.*, 1980, **52**, 1716.
- [53] P. Uden, in *Environmental Analysis Using Chromatography Interfaced With Atomic Spectroscopy*. ed. R. M. Harrison and S. Rapsomanikis, Ellis Horwood, Chichester, 1989, ch. 4.
- [54] K. E. Le Freniere, V. A. Fassel and D. E. Eckels, *Anal. Chem.*, 1987, **59**, 879.
- [55] K. J. Irgolic, R. A. Stockton, D. Chakraborti and W. Beyer, *Spectrochim. Acta*, 1983, **38B**, 437.
- [56] J. Ruzicka and E. H. Hansen, *Anal. Chim. Acta*, 1975, **78**, 145.
- [57] Z. Fang, *Microchem. J.*, 1992, **45**, 137.
- [58] S. Greenfield, *Ind. Res. Dev.*, 1981, **21**, 140.
- [59] K. McLaughlin, D. Dadgar, M. R. Smyth and D. McMaster, *Analyst*, 1990, **115**, 275.

- [60] M. D. Luque de Catro, *Talanta*, 1986, **33**, 45.
- [61] S. Vijayakshimi, R. Krishna Prabhu, T. R. Mahalingham and C. K. Matthews, *J. Anal. At. Spectrom.*, 1992, **7**, 565.
- [62] R. F. Browner and A. W. Boorn, *Anal. Chem.*, 1984, **56**, 787A.
- [63] J. W. Novak, D. E. Lillie, A. W. Boorn and R. F. Browner, *Anal. Chem.*, 1980, **52**, 579.
- [64] R. F. Suddendorf and K. W. Boyer, *Anal. Chem.*, 1978, **50**, 1769.
- [65] K. W. Olson, W. J. Haas Jr. and V. A. Fassel, *Anal. Chem.*, 1977, **49**, 632.
- [66] P. W. J. M. Boumans and F. J. de Boer, *Spectrochim. Acta Part B*, 1975, **30**, 309.
- [67] P. W. J. M. Boumans and F. J. de Boer, *Spectrochim. Acta Part B*, 1976, **31**, 355.
- [68] M. H. Hahn, K. A. Wolnik, F. L. Fricke and J. A. Caruso, *Anal. Chem.*, 1982, **54**, 1048.
- [69] T. Nakahara, *Prog. Anal. At. Spectrosc.*, 1983, **6**, 163.
- [70] K. E. Lawrence, G. W. Rice and V. A. Fassel, *Anal. Chem.*, 1984, **56**, 289.
- [71] K. E. LaFreniere, V. A. Fassel and D. E. Eckels, *Anal. Chem.*, 1987, **59**, 879.
- [72] J. W. Carr and G. Horlick, *Spectrochim. Acta, Part B*, 1982, **37**, 1.
- [73] M. Thompson, J. E. Coulter and F. Sieper, *Analyst (London)*, 1981, **106**, 32.
- [74] H. G. C. Human, R. H. Scott, A. R. Oakes and C. D. West, *Analyst (London)*, 1976, **101**, 265.
- [75] J. Y. Marks, D. E. Fornwalt and R. E. Yungk, *Spectrochim. Acta, Part B*, 1983, **38**, 107.
- [76] D. L. Millard, H. C. Shan and G. F. Kirkbright, *Analyst (London)*, 1980, **105**, 502.
- [77] A. Aziz, J. A. C. Broekaert and F. Leis, *Spectrochim. Acta, Part B*, 1982, **37**, 369.
- [78] W. C. Wiley and I. H. McLaren, *Rev. Sci. Instrum.*, 1955, **26**, 1150.
- [79] T. Bergman, T. P. Martin and H. Schaber, *Rev. Sci. Instrum.*, 1989, **60**, 347.

2. SPECIATION VIA FLOW ANALYSIS.	38
2.1. Introduction.	39
2.2. Experimental	51
2.3. Results and Discussion.	61
2.3.1. Deposition/Elution of Selenium IV and VI on Acidic Alumina.	61
2.3.2. Analytical Performance.	66
2.3.3. Deposition/Elution of Selenium Species on Sulphydryl Cotton Fibre.	72
2.3.4. Analytical Performance.	75
2.4. Conclusions and Further Work.	77
2.5. References.	81

2.1. Introduction.

This research covers the use of flow analysis techniques to perform speciation on selenium. The flow injection manifolds incorporate microcolumns of acidic activated alumina and sulphhydryl cotton fibre to perform both the separation of selenium(IV) / selenium(VI), and preconcentration. Because the element specific detection systems used, ICP-AES and ICP-MS were not sensitive enough to measure selenium at environmental levels, preconcentration was required. As well as preconcentration, further increases in sensitivity were required. The easiest way to achieve this is to improve the sample introduction to the ICP. This was achieved by incorporating an ultrasonic nebuliser in the system set-up.

Initial studies were performed on the ICP-AES system, even though this system is far less sensitive than ICP-MS, it is a much more robust system. This allows development of the methods to be performed without the concerns of damaging expensive instrumentation. However, it is not possible to simply transfer methods from one technique to the other. Further concerns over the total dissolved solids in a sample and different interferences have to be taken into consideration. This is why further development work is required during the switch from ICP-AES to ICP-MS.

This work will firstly characterise the interaction of both selenium species on an acidic activated alumina microcolumn, then on a microcolumn of sulphhydryl cotton fibre, and finally a combination of both systems.

After the discovery of selenium by Berzilius in 1817, the element rapidly became known as one of the most toxic elements to mammals^[1-4]. There are varying degrees of selenosis, ranging from “alkali disease”, a chronic mild form, to “blind staggers”, an acute state that can result in death^[5].

Chronic selenium poisoning results in hair loss, soreness of joints and sloughing of hooves, animals become lame and stiff. Other findings include liver cirrhosis and anaemia. Chronic selenosis was observed in copper refinery workers where symptoms were a strong garlic odour of breath, sore throats, coryza and gastrointestinal irritation^[6]. The occurrence of dermatitis and a red staining of fingers, teeth and hair have also been reported^[7].

In acute selenosis, animals suffer from blindness, abdominal pain and some degree of paralysis. Salivation, disturbed respiration and grating of teeth is observed, with death resulting from respiratory failure.

However, in 1957, Schwarz and Foltz^[8] found that selenium was essential in normal metabolism when they prevented liver necrosis in diet-deficient rats. Selenium is an essential component of the enzyme glutathione peroxidase (GSH-Px)^[9]. This enzyme prevents oxidative damage to a variety of biological structures and forms an important role along with vitamin E in the cellular defence against free radical attack^[10].

Selenium has been found to have a relationship with many diseases and has been shown in many studies to reduce the incidence of many different cancers in animals. Sodium selenide when added to the backs of mice treated with 7,12-dimethylbenzanthracene (DMBA), significantly reduced the number of skin lesions^[11]. The incidence of liver tumours induced by dimethylaminobenzene (DAB) was reduced in rats by adding selenium to drinking water^[12]. This also reduced the incidence of 1,2-dimethylhydrazine (DMH) induced colon tumours by more than 50%^[13]. Schrauser and Ishmael^[14] added sodium selenite to the drinking water of mice and observed a reduced incidence of breast tumours caused by the Bittner milk virus from 82% to 10%. In humans, different studies have shown an inverse relationship between environmental selenium concentrations and the incidence of cancer^[15, 16].

Studies have shown that there is also an inverse relationship between selenium levels in the environment and coronary heart disease^[17]. In severely selenium deficient areas of China a severe congestive heart disease called Keshan disease is found. Mortality from Keshan disease is high, but this was dramatically reduced when treatment with sodium selenite was administered^[18]. A comprehensive study by Burke *et al.* showed how

Kwashiorkor, a syndrome produced by a severe protein deficiency in the diet, could be treated by the administration of selenium in the diet^[19]. There are many other diseases for which there is evidence of a relationship with selenium, these include cystic fibrosis, multiple sclerosis, cataracts, Keshan-Beck disease and infertility. However, these fields need to be more extensively researched.

Although the levels at which selenium is essential or toxic are not fully understood, it is believed that these levels are very close to each other. The USA and Canadian regulations for total selenium levels establish maximum permissible levels of 0.1-0.2 $\mu\text{g/l}$ in air^[20] and 8-10 $\mu\text{g/l}$ in drinking water^[21]. It is therefore essential that selenium levels in the environment are fully investigated.

In the environment, elemental selenium is generally associated with sulphur and is found in metal-sulphur deposits. Total selenium levels in the environment range from 0.1-400 $\mu\text{g/l}$ in natural waters^[22] to 1 ng/l in the atmosphere^[23] and 0-360 $\mu\text{g/l}$ in soils^[3]. Individual species concentrations, however, can be at the ng/l level^[24]. Selenium is released into the environment by weathering processes and by the many industrial processes it is involved in. Selenium compounds are widely used in glass manufacture, electronic applications, photocopying machines, inorganic pigments, rubbers, ceramics, plastics, lubricants, etc. These applications are summarised in Table I.

For an accurate assessment of the environmental impact of selenium not only does the availability and mobility of the total selenium concentration need to be known, but further information about the chemical forms in which selenium exists is required. Selenium can exist in a variety of forms and oxidation states viz. selenide (SeII), elemental selenium, selenite (Se IV), selenate (Se VI), dimethylselenide (DMSe), dimethyldiselenide (DMDS₂) and inorganic compounds. The principle selenium species in the environment are selenite and selenate.

The toxicology of selenium is very much dependent on its chemical form^[25]. For instance, unicellular marine algae did not survive in a medium containing 10 ppm selenium in the form selenate, however, selenite was tolerated at concentrations as high as 100 ppm^[26]. It is therefore essential to be able to determine not only total selenium concentrations, but also, species concentrations.

Current methods for the determination of selenium have been reviewed^[24,27,28]. Many methods have been developed to determine selenium species in various matrices, and these are summarised in Table II.

Compound	Use
Selenium	Rectifiers, photoelectric cells, blasting caps, in xerography, stainless steel; dehydrogenation catalyst.
Sodium Selenate Na ₂ SeO ₄	As insecticide; in glass manufacture; in medicines to control animal diseases.
Sodium Selenite Na ₂ SeO ₃	In glass manufacture; as soil additive for selenium deficient areas.
Sodium Diethyldithiocarbamate	Fungicide; vulcanising agent.
Sodium Disulphide SeS ₂	In veterinary medicine.
Selenium Dioxide SeO ₂	Catalyst for oxidation, hydrogenation or dehydrogenation of organic compounds.
Selenium Monosulphide SeS	In veterinary medicine.
Selenium Hexafluoride SeF ₆	As gaseous electric insulator.
Selenium Oxychloride SeOCl ₂	Solvent for sulphur, selenium, tellurium rubber, bakelite, gums, resins, glue, asphalt and other materials.
Aluminium Selenide Al ₂ Se ₃	Preparation of hydrogen selenide for semiconductors.
Ammonium Selenite (NH ₄) ₂ SeO ₃	Manufacture of red glass.
Cadmium Selenide	Photoconductors, photoelectric cells, rectifiers.
Cupric Selenate CuSeO ₄	In colouring copper and copper alloys.
Tungsten Diselenide WSe ₂	In lubricants.

Table I. Some selenium compounds and their uses (*L. Fishbein, Int. J. Environ. and Anal. Chem., 1984, Vol. 17, pp. 113-170*).

Species	Matrix	Analytical Method	Detection limit.	Ref.
Se(IV), Se(VI)	Natural waters	MFS	5 ng/l	[29]
Se(IV), Se(VI)	Vegetable crops, soils	GLC-ECD	2 ng/l	[30] [31]
Se(IV)	Soil extracts	LC-CD	110 µg/l	[32]
Se(VI)			60 µg/l	
Se(IV), Se(VI)	Natural waters	HG-QFAAS	3 ng/l	[33]
Se(IV), Se(VI)	Ground Waters	IC-HG-AAS	10 ng/l	[34]
Se(IV), Se(VI)	Sediments, biogenic particles	HG-AAS	10 ng/l	[35]
Se(IV), Se(VI)	Milli-Q water	LC-ICP-AES	54 ng/l	[36]
TMSe			14 ng/l	
DMSe, DMDS	Synthetic air samples	GC-AAS	0.2 ng/l	[37]
DMSe, DMDS	Oil Fuel	GC-MIP-AED		[38]
DMSe, DMDS	Breath of mice	GC-GFAAS	0.2 ng/l	[39]
DMSe	Air	GC-GFAAS	0.1 ng/l	[32]
DMDS			0.2 ng/l	
DESe			0.1 ng/l	
SeME, SeCYS	Erythrocytes	LC-MS		[40] [41]
Elemental Se(0)	Milli-Q water	HG-ICP-AES	0.6 µg/l	[42]
Total inorganic Se	Milli-Q water	HG-UV	1 mg/l	[43]
Total Se	Natural water	ID-MS	10 ng/l	[44]
Total Se	Biological material	HG-ICP-MS	1.3 ng/g	[45]

Table II. Summary of techniques used to determine selenium compounds

The limits of detection of ICP-AES and ICP-MS for selenium using conventional sample introduction techniques are typically 30 and 4 µg/l, respectively. The relatively poor detection capability of selenium by ICP mass spectrometry is a direct consequence of the poor ionisation of selenium by the ICP and having to use isotopes of relatively low abundance (⁷⁶Se, ⁸²Se) due to the fact that the major isotopes ⁸⁰Se and ⁷⁸Se, are compromised by the argon dimers ⁴⁰Ar₂ and ⁴⁰Ar³⁸Ar.

Selenium is polyisotopic, i.e. it has more than one isotope, these are listed in Table III.

Atomic Mass Unit	74	76	77	78	80	82
% Abundance	0.9	9.0	7.6	23.6	49.7	9.2

Table III. Isotopic abundance of selenium

Although the isotope at mass 80 accounts for nearly 50% of the selenium, this mass is not used in conventional ICP-mass spectrometry to determine selenium, as it is severely interfered by the background species ⁴⁰Ar₂⁺. Many of the other selenium isotopes are also interfered by background species, as shown in Fig. 1.

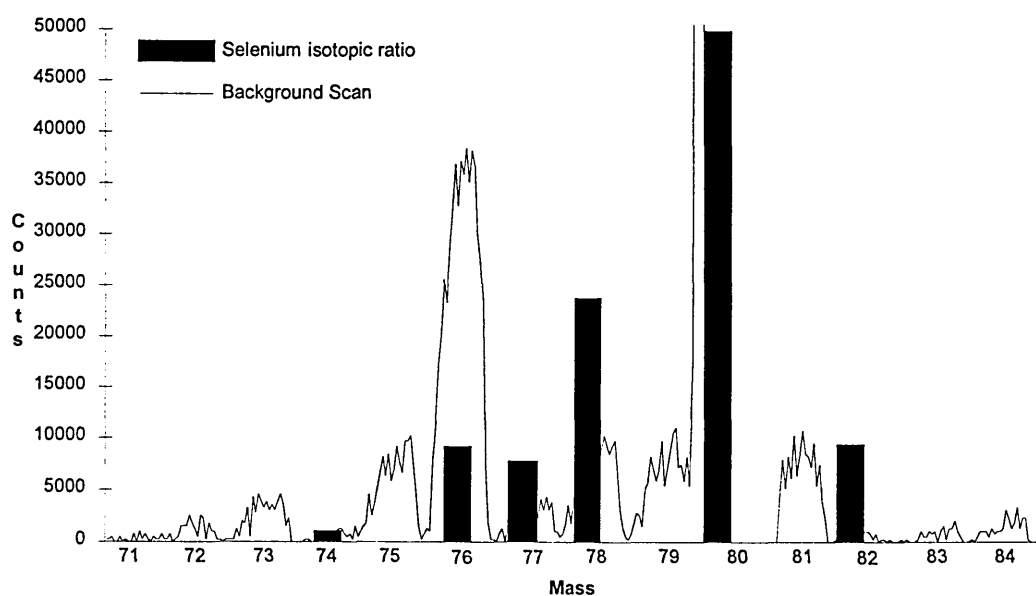

Fig. 1. Scan of masses 71-84 (Skipping mass 80) while aspirating distilled water. Overlay of the isotopic abundance of selenium

Although the selenium isotope at mass 78 is the next most abundant isotope, it too has a severe background interference, $^{38}\text{Ar}^{40}\text{Ar}^+$. The selenium isotope with the best signal to background ratio is the selenium-82 isotope, this however, only accounts for 9.2% of the total selenium present. The small background signal at this mass is due to krypton-82, which is present as a contaminant in the argon gas used for the plasma.

Hydride generation in combination with electrothermal atomic absorption spectrometry is the most commonly used method for the determination of selenium in environmental waters, giving detection limits of 3 ng/l, when combined with cryogenic trapping^[33]. Hydride generation when combined with ICP emission spectrometry yields a detection limit of 1.3 $\mu\text{g/l}$ ^[46], while with ICP mass spectrometry detection limits are approximately 10 fold lower^[47]. Hydride generation, however, is plagued by numerous interferences^[48-50] and the analyte must be present as the selenium(IV) species prior to the evolution step. Reduction of selenium(VI) to selenium(IV) allows the determination of total selenium with selenium(VI) concentrations being determined by difference. Lack of control in the reduction is thought to explain some of the literature discrepancies concerning selenium concentration levels in environmental waters.

Flow analysis systems have been used to determine both total selenium levels and species levels^[51-54]. Some of the flow injection manifolds used are shown in Figs. 2, 3, 4 and 5. The flow injection systems in Figs. 2 and 3, both use hydride generation in combination with atomic absorption spectrometry. Flow injection is used to speed up analysis times. The manifold in Fig. 2 can process 50 samples per hour compared to 25 samples per hour using continuous flow systems. The manifold in Fig. 4 uses a column of resin loaded with bismuthiol-II sulphonate potassium salt, this retains selenium(IV) allowing preconcentration. The selenium(IV) is eluted from the column using penicillamine, and is then used to catalyse the reduction of 3-(4,5-Dimethyl-2-thiazolyl)-2,5-diphenyl-2H tetrazolium bromide (MTT) by dithiothreitol (DTT) to formazan, which is detected at 565 nm. Detection limits lower than 0.1 $\mu\text{g/l}$ can be achieved by this manifold preconcentration scheme. The chemistry utilised by the manifold in Fig. 5 is a colorimetric procedure, where selenium(IV) catalyses the reaction between chlorate and hydrazine, the coloured oxidation product of *o*-tolidine is

observed at 440 nm. All of the procedures determine the selenium(IV) species only. Selenium(VI) levels can be determined by difference after a total selenium concentration is obtained by off-line sample pretreatment to ensure that all of the selenium species are present as selenium(IV). Analytical systems are still required which determine selenium(IV) and selenium(VI) independently.

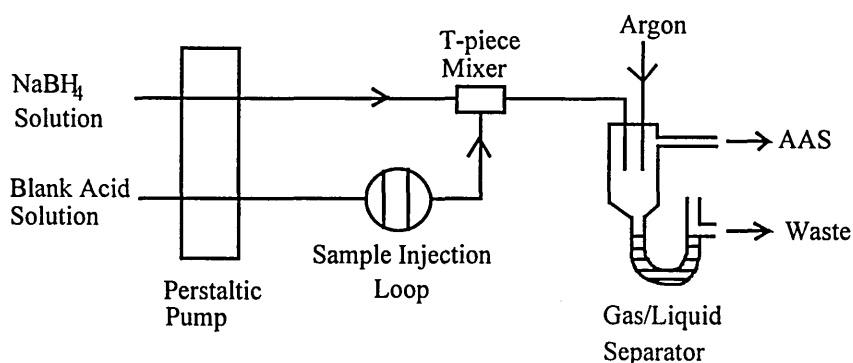

Fig. 2. Schematic diagram of an FI hydride generation system for selenium analysis. (K. McLaughlin et al., *Analyst*, 1990, 115, 276)

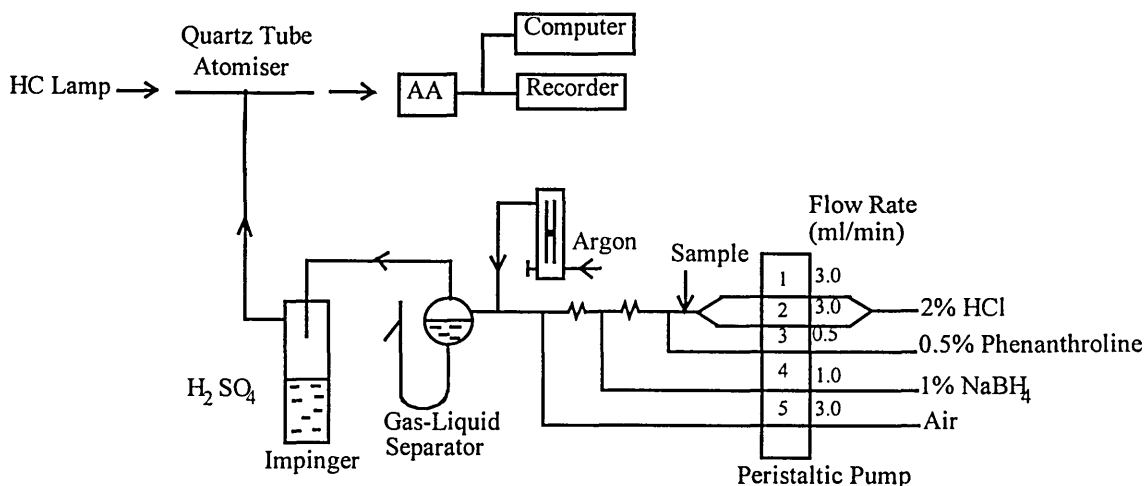

Fig. 3. Analytical system for determination of selenium hydride by automated FIA and hydride AAS. (C. C. Y. Chan and R. S. Sadana, *Anal. Chim. Acta*, 1992, 270, 231.)

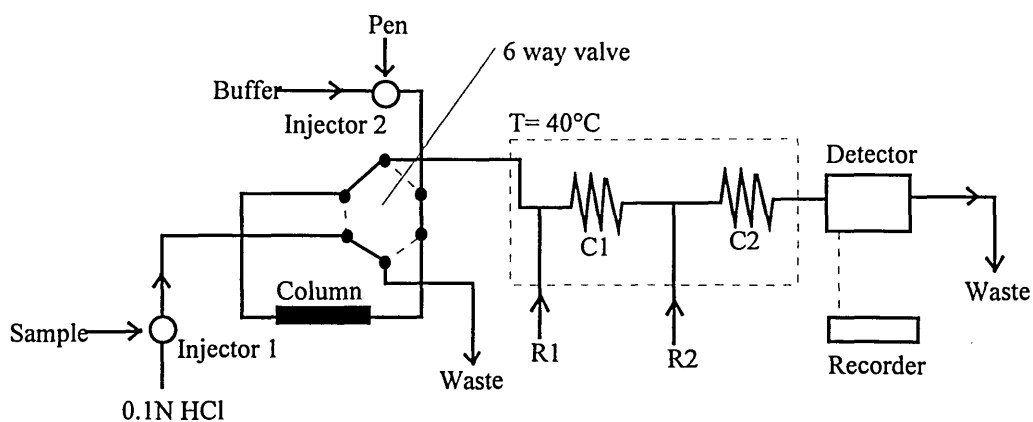

Fig. 4. FIA system with on-line pre-concentration of Se(IV). (*E. Aoyama et al., Anal. Sci., 1991, 7, 617.*)

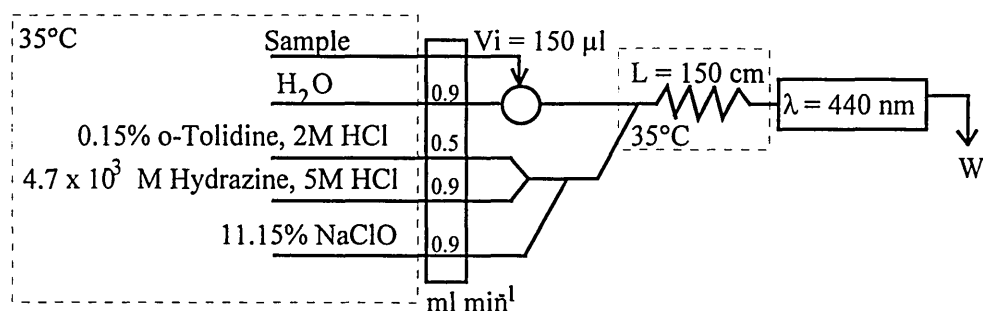

Fig. 5. FIA manifold used for selenium speciation using a colorimetric procedure. (*P. Linares et al., Analyst, 1986, 111, 1405.*)

In this research microcolumns were utilised in combination with flow injection to both pre-concentrate and separate the selenium species. Two column packing materials were characterised for their ability to perform these tasks. These packing materials were activated alumina, utilised because earlier studies have shown that acidic alumina has an affinity for oxyanions, and sulphhydryl cotton, as selenium acts on sulphhydryl sites in the body.

Activated alumina is the common name for gamma aluminium oxide ($\gamma\text{-Al}_2\text{O}_3$). The basic method of preparation is low temperature dehydration of hydrous aluminium oxides at 300-700 °C. It differs from high temperature alumina ($\alpha\text{-Al}_2\text{O}_3$) in that it readily takes up water and dissolves in acids. Both forms are soluble in strong alkalis.

Activated alumina has many uses in the field of adsorption, where its high surface area, pore structure, physical characteristics and chemical inertness are factors favouring its

applications. The earliest known use of activated alumina was in the chromatographic purification of liver extracts^[55]. Alumina has been a common column packing material for chromatographic separations from its beginnings in the 1930's. Alumina has a very complex surface that is dependent upon pretreatment and chemical environment, it is amphoteric in nature, and so its ion exchange properties are very pH dependent.

Umland^[56] described the "precipitation adsorption" of cations by untreated basic aluminas containing hydroxides and carbonates. These methods have been used to separate and preconcentrate Fe^{3+} , Cu^{2+} , Co^{2+} , Ni^{2+} , Ag^+ , Pb^{2+} , and other cations. He also presented data indicating that the common anions are preferred in the following order by acidic activated alumina:

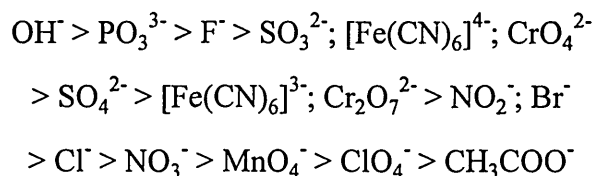

The anion exchange procedure given above is basically that of the solubility of aluminium salts. The more preferred ions can be used to displace lesser preferred ions. Thus activated alumina is seen to be an inorganic ion exchanger with an anion selectivity sequence different from that of typical weak-base synthetic organic anion exchange resins to which it is functionally similar.

A greatly simplified representation of the adsorption/elution cycle for fluoride on activated alumina can be visualised as follows:

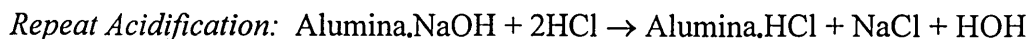
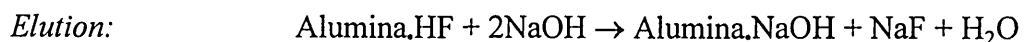

As well as acting as an anion exchange material, covalent bonds can form between the alumina and species with lone pairs of electrons.

The use of activated alumina in microcolumns for on-line trace enrichment in flow injection-ICP-spectrometry has been well documented^[57-69]. In an early study^[59], it was

reported that acidic alumina exhibits a high affinity for oxyanions and as a result highly sensitive methods were developed for the determination of phosphorus in steel^[57] and sulphate in waters^[60] and high purity iron^[64].

Although both selenium species undergo deposition on the acidic activated alumina, as is typical for alumina's anion exchange properties. When the selenium species pass through the alumina microcolumn, the selenium(IV) species forms a covalent bond with the alumina. It is able to do this because its chemical structure leaves it with a lone pair of electrons. Selenium(VI) does not possess a lone pair of electrons and so does not form a covalent bond with the alumina. This difference in bonding is exploited to separate the two selenium species, with eluents of different strengths being used to selectively remove each selenium species.

Initial characterisation studies and basic performance are reported for ICP emission spectrometry. The microcolumn enrichment technique was also successfully combined with ICP mass spectrometry, incorporating ultrasonic nebulisation to increase the sample introduction efficiency, in order to quantify selenate in natural waters at the ng/l level.

Procedures cannot, however, simply be transferred from ICP-emission spectrometry to ICP-mass spectrometry. Problems occur when the procedure to separate selenium species using activated alumina is applied to ICP-mass spectrometry. This procedure requires the use of potassium hydroxide (2.0M) to elute the selenium(IV) species from the activated alumina. Potassium interferes at mass 82, this is due to the formation of $^{41}\text{K}_2^+$ in the plasma. A comparison of the signals for aspirating distilled water and potassium hydroxide (0.5M) can be seen in Fig. 6, along with a close-up of the background shift at mass 82 when aspirating potassium hydroxide (0.5M).

A second problem, which prevents us from simply replacing potassium hydroxide with sodium hydroxide, is the total dissolved solids content. The interface of the ICP-MS restricts the type of sample which may be aspirated into the plasma. To prevent the sampling orifice from becoming blocked, a total dissolved solids content of around 0.2% is recommended. Therefore, the determination of selenium(IV) was precluded, and

only the determination of selenium(VI) could be carried out using the activated alumina manifold system when attached to ICP-mass spectrometry.

(a)

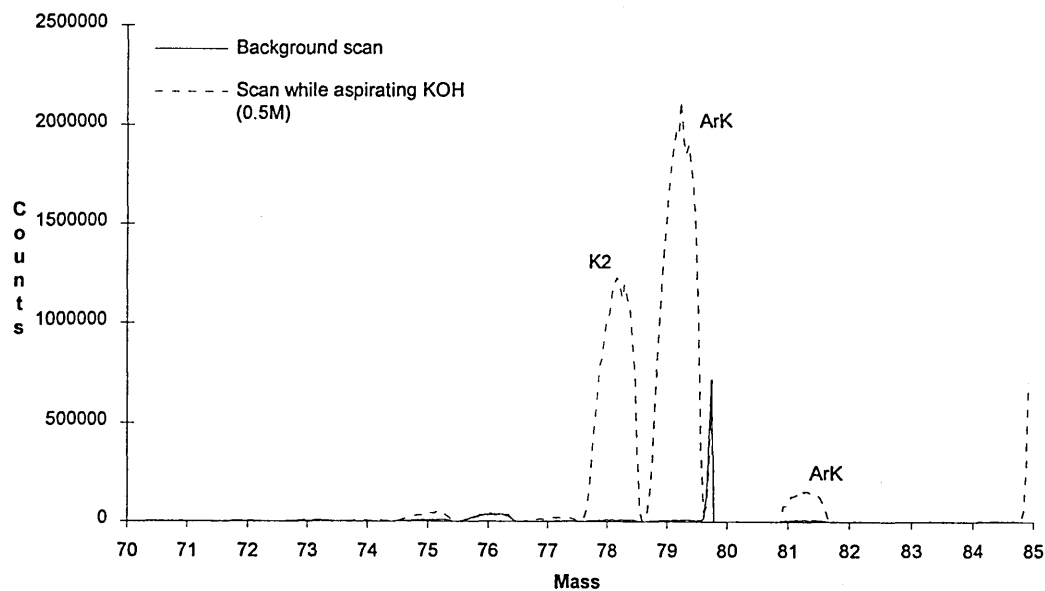

(b)

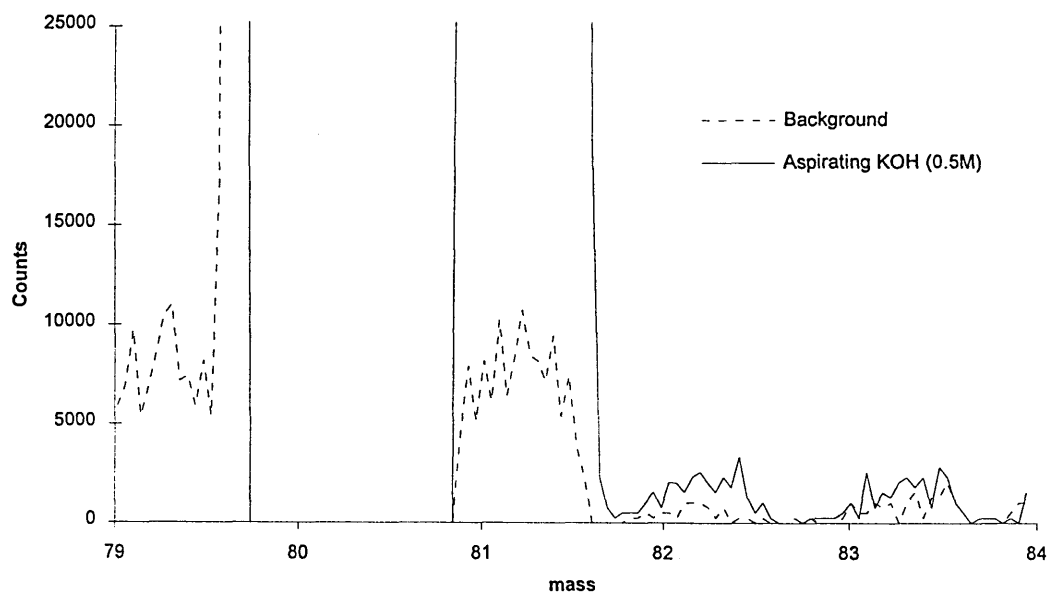

Fig. 6. Mass Scan (a) 71-84 showing peaks due to polyatomic ions containing potassium. (b) close-up of mass 79-84 showing the rise in background due to $^{41}\text{K}_2^+$.

These problems excluded the analysis of selenium(IV) using acidic activated alumina in combination with ICP mass spectrometry. Therefore, a separate means of performing selenium(IV) analysis was required.

It is believed that selenium induces its toxicity by the inactivation of sulphhydryl-containing enzymes. It is therefore of interest to see whether microcolumns of sulphhydryl cotton fibre could retain and preconcentrate selenium species. Dai and Zhou^[70], Yi^[71], and Yao and Li^[72] have all used sulphhydryl cotton fibre to preconcentrate selenium prior to its reaction with hydride generating reagents. These methods were performed off-line and require the destruction of the cotton fibre to release the selenium for analysis. These methods determine either total selenium or selenium(IV) levels. However, microcolumns of sulphhydryl cotton fibre have been used to preconcentrate and speciate inorganic and organic mercury^[73,74] in flow injection manifolds on-line prior to detection by atomic fluorescence spectrometry.

During the preparation of sulphhydryl cotton fibre, sulphur-sulphur bonds are formed (disulphides). The disulphide bond is susceptible to cleavage by nucleophilic attack:



The nucleophile can be the selenium(IV) species, as it has a lone pair of electrons. The selenium(IV) species is therefore deposited onto the sulphhydryl cotton fibre. The selenium(VI) species does not have a lone pair of electrons and so is not retained by the sulphhydryl cotton fibre as it cannot perform the nucleophilic attack. This difference in bonding can be exploited to perform the separation of selenium(IV) and selenium(VI).

A combination of the acidic alumina and sulphhydryl cotton columns will allow the preconcentration and separation of selenium(IV) and selenium(VI) by flow injection - ICP - mass spectrometry.

2.2. Experimental

The flow injection (FI) system illustrated in Fig. 7, was designed to provide rapid separation of selenium(IV) and selenium(VI) species. The main components of the FI system was a peristaltic pump (Gilson), a rotary injection valve (Omnifit) and a microcolumn of either alumina or sulphhydryl cotton fibre. The end of the FI system was connected directly to the inlet tubing of a nebuliser attached to either an ICP emission spectrometer or an ICP mass spectrometer.

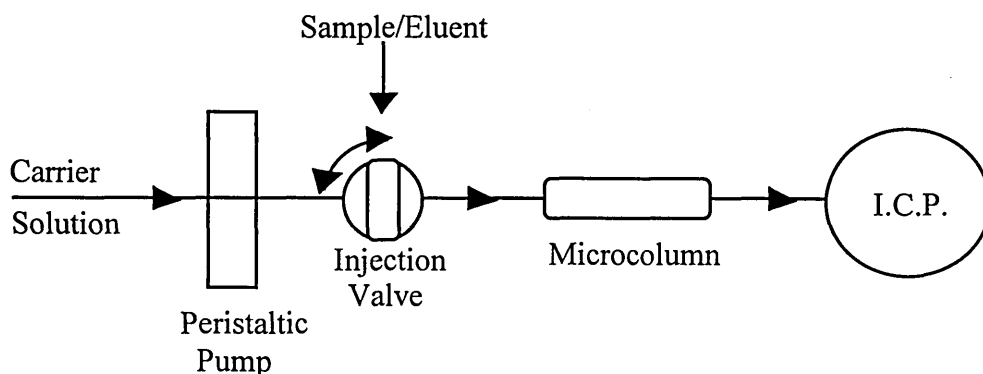

Fig. 7 Schematic of FI manifold.

The rotary injection valve allows a known, fixed volume of liquid to be injected into the carrier stream reproducibly. The valve is operated in either an inject or load position, as shown in Fig. 8. In the load position, the loop is filled with sample while carrier solution passes to the ICP. The valve is then switched to the inject position, the loop containing the sample is brought on-line and the sample injected into the carrier stream to the ICP.

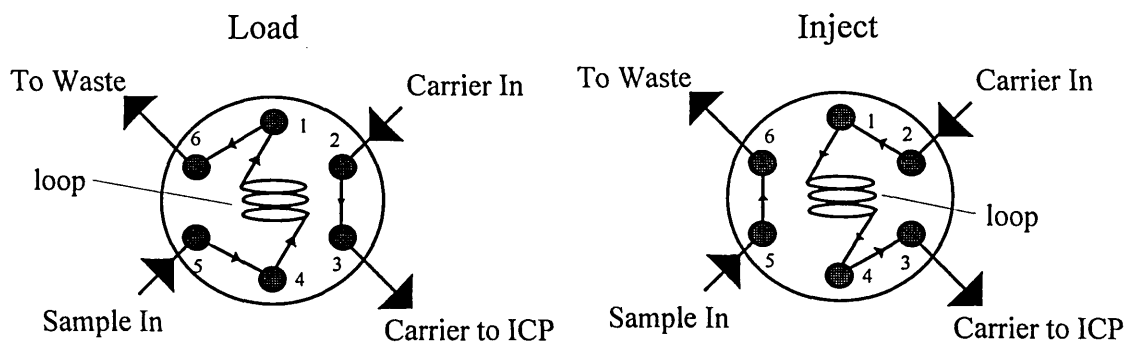

Fig. 8 Load/Inject positions of a rotary injection valve.

The microcolumns packed with either activated alumina or sulphhydryl cotton fibre were of a similar design, see Fig. 9.

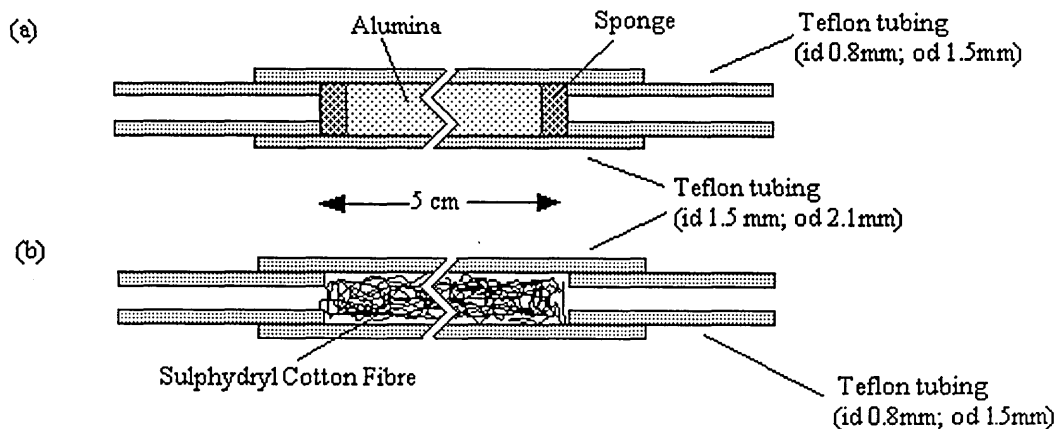

Fig. 9. Representations of (a) activated alumina microcolumn and (b) sulphhydryl cotton fibre microcolumn.

The activated alumina microcolumn was constructed from Teflon tubing (id 1.5 mm, 5 cm). A small piece of sponge was inserted in one end of the microcolumn. The activated alumina (Brockmann Grade 1, Acidic Form, BDH) was sieved and particle size 150-180 μ m was used to fill the microcolumn. This particle size was previously determined

to prevent 'clogging' of the microcolumn, while still giving optimum sites for analyte deposition. A second piece of sponge was then inserted in the other end of the microcolumn to contain the alumina.

The sulphhydryl cotton fibre microcolumn was similar in construction to the alumina microcolumn. Again, Teflon tubing (id. 1.5 mm, 5 cm) was used, but, this time no sponge was required, as the sulphhydryl cotton fibre was self-containing. The sulphhydryl cotton fibre was prepared as follows, thioglycollic acid (50 ml, 97% m/m, GPR, BDH), acetic anhydride (30 ml, 36% m/m, GPR, BDH), acetic acid (20 ml, 30% m/m, BDH) and sulphuric acid (0.15 ml, 96%, GPR, BDH) were mixed thoroughly. The mixture was cooled to room temperature and absorbent cotton (15 g), was added and left to soak. The stoppered flask was then placed in an oven at 40°C and left for 4 days. Thereafter, the cotton fibre was washed with water until the washings were between pH 6-7 and the material dried at 40 °C. The dried cotton was then transferred to a sealed light free container for storage and used for column packing. Small portions of the cotton were pushed down gently, to fill the microcolumn using a paper clip.

The procedure to separate selenium(IV) and selenium(VI) was;

Alumina;

Sample solutions were passed through the microcolumn for specified time periods at a flow-rate of 1 ml/min to effect deposition of the analyte on the alumina. An injection of ammonium hydroxide (250 µl, 0.1M) was used to elute selenium(VI) species into the ICP. After 60 seconds, an injection of potassium hydroxide (250 µl, 2.0M) was used to

elute selenium(IV) species into the ICP. Residual selenium is removed by four further injections (250 µl) of potassium hydroxide before further samples were processed. A carrier stream of nitric acid (0.001M) was used to maintain the acidity of the activated alumina.

Sulphydryl cotton fibre;

Sample solutions were passed through the microcolumn for specified time periods at a flow rate of 1 ml/min to effect the deposition of selenium(IV) on the sulphydryl cotton fibre. Selenium(VI) was not retained by the sulphydryl cotton fibre and so passed straight through to the ICP. An injection of ammonium hydroxide (250 µl, 0.1M) was used to elute the selenium(IV) to the ICP. Residual selenium(IV) was removed by an injection (250 µl) of ammonium hydroxide before further samples were processed. A carrier stream of nitric acid (0.01M), was required to effect the deposition of selenium(IV) on sulphydryl cotton fibre.

2.1.3. ICP-Emission Spectrometry

Inductively coupled plasma - atomic emission spectrometry (ICP-AES) instruments consists of a sample introduction system, an inductively coupled plasma emission source and a spectrometer to analyse the light emitted by the plasma. A representation of the layout of an ICP-AES instrument is shown in Fig. 10

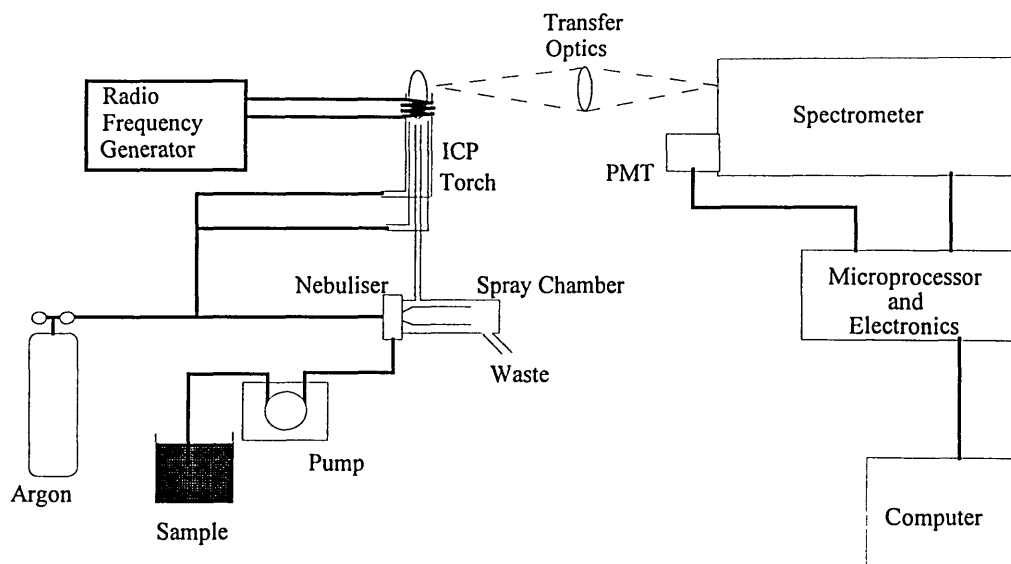

Fig. 10 Representation of an ICP-AES system.

In this work two ICP-emission spectrometers were used, a Thermo Jarrel ICAP 9000 and a SpectroAnalytical Spectroflame D. The work was carried out on two systems as the Spectroflame D became unavailable for use during the research.

Selenium has many emission lines, as shown in Table IV. By far the most sensitive line is the emission line at 196.020 nm, which was used by both ICP systems to determine the selenium content of a sample.

Line (nm)	Relative Sensitivity
162.940	170
167.120	200
167.530	170
169.070	100
185.520	3000
185.880	450
196.020	13500
203.985	9
206.279	3
207.479	1

Table IV. Emission lines of selenium.

The radiation emitted by selenium is separated from all the other radiation emitted by the plasma using a spectrometer, it is here that the two instruments differ. The function of a spectrometer is to focus the light from the plasma into a well-defined beam, direct it to a grating which disperses the light into its component wavelengths, and focuses the component wavelengths on a circle. An exit slit on the circle then allows only the 196.020 nm wavelength to pass to the detector while blocking out other wavelengths.

Both ICP systems used a Paschen-Runge mount type of spectrometer, see Fig. 11. However, in the Spectroflame D it was a monochromator, while in the ICAP 9000 it was a polychromator. The Spectroflame D changed the position of the exit slit to allow it to measure the 196.020 nm wavelength, while the ICAP 9000 spectrometer was fixed, with an exit slit and detector specifically for the 196.020 nm wavelength.

Both ICP systems used a similar detection system to measure the intensity of the emission line, a photomultiplier tube. The photomultiplier tube is a vacuum tube which contains a photosensitive material (photocathode), that ejects an electron when it is struck by light. These electrons are directed towards a dynode which ejects 2 to 5 electrons for every electron which strikes its surface. These secondary electrons then strike another dynode which ejects more secondary electrons, causing an electron cascade. As many as 10^6 electrons can be produced for every photon striking the photocathode. These electrons are collected on the anode, the electric current measured is used as a relative measurement of the intensity of light reaching the detector.

(a)

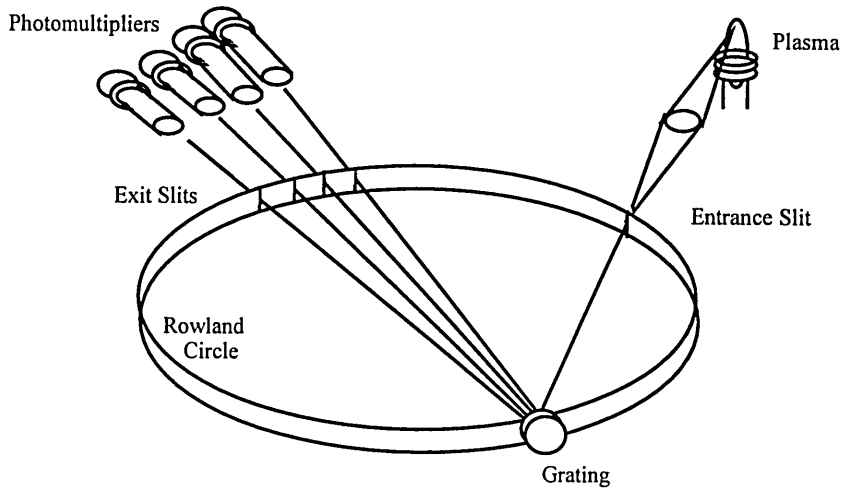

(b)

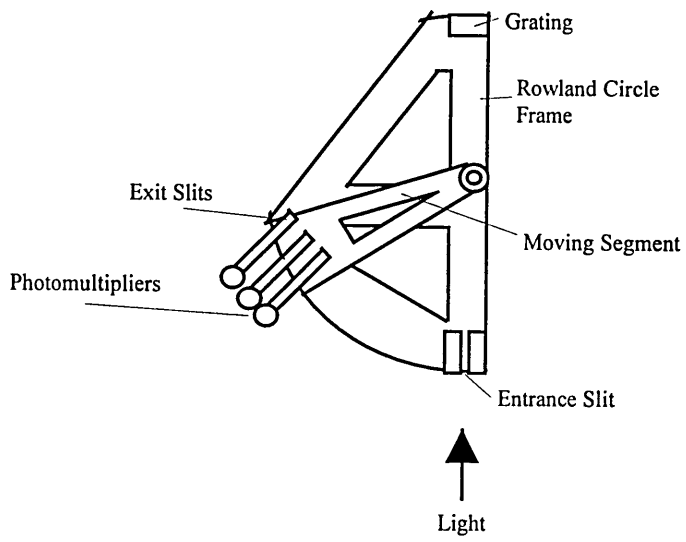

Fig. 11 Schematic of the spectrometers used in (a) ICAP 9000, and (b) Spectroflame D.

Typical operating conditions were;

Forward power	1100 W
Reflected power	< 10 W
Coolant gas flow	15 L/min
Auxiliary gas flow	1.0 L/min
Carrier gas flow	1.0 L/min
Sample uptake	1.0 ml/min
Observation height	Optimised
Wavelength	196.02 nm

2.1.4. ICP-Mass Spectrometry.

To increase sensitivity an ICP-mass spectrometer (PlasmaQuad II+, Fisons Instruments) was used, see Fig. 12. The ICP is an extremely efficient producer of ions. Instead of measuring the intensity of the light emitted by the analyte, the ICP-mass spectrometer measures the ions produced.

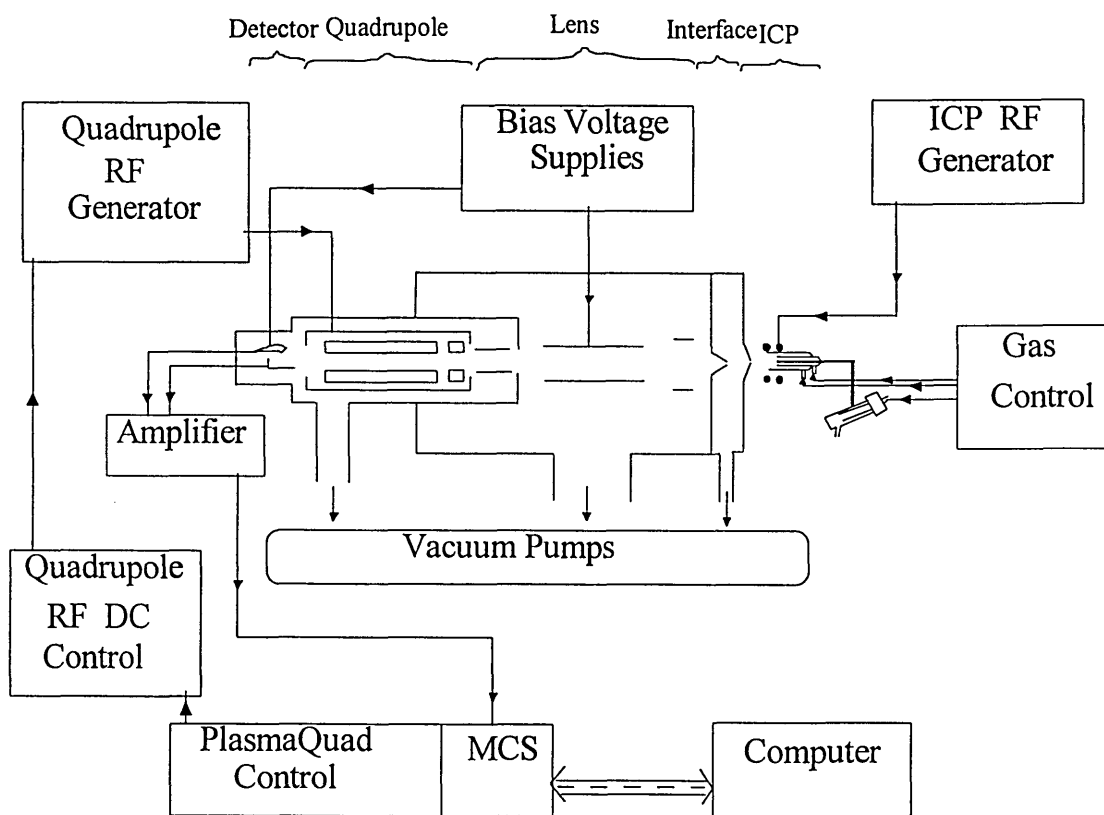

Fig. 12 Schematic of the PlasmaQuad II+.

The ICP, operates at atmospheric pressure, while the quadrupole mass filter used in the PlasmaQuad II+ operates at extremely low pressures ($\sim 10^{-6}$ mbar). Therefore, the interface between the ICP and the mass spectrometer is extremely critical. Ions produced in the plasma are extracted using a sampling cone and a skimmer cone. Ions flow through the sampling orifice into a area of lower pressure, where a supersonic jet forms. The central section of the jet then flows through the skimmer orifice.

Once the ions leave the skimmer, they enter an intermediate region at a lower pressure. Here ion lenses are situated to direct and confine the ions on their way to the quadrupole.

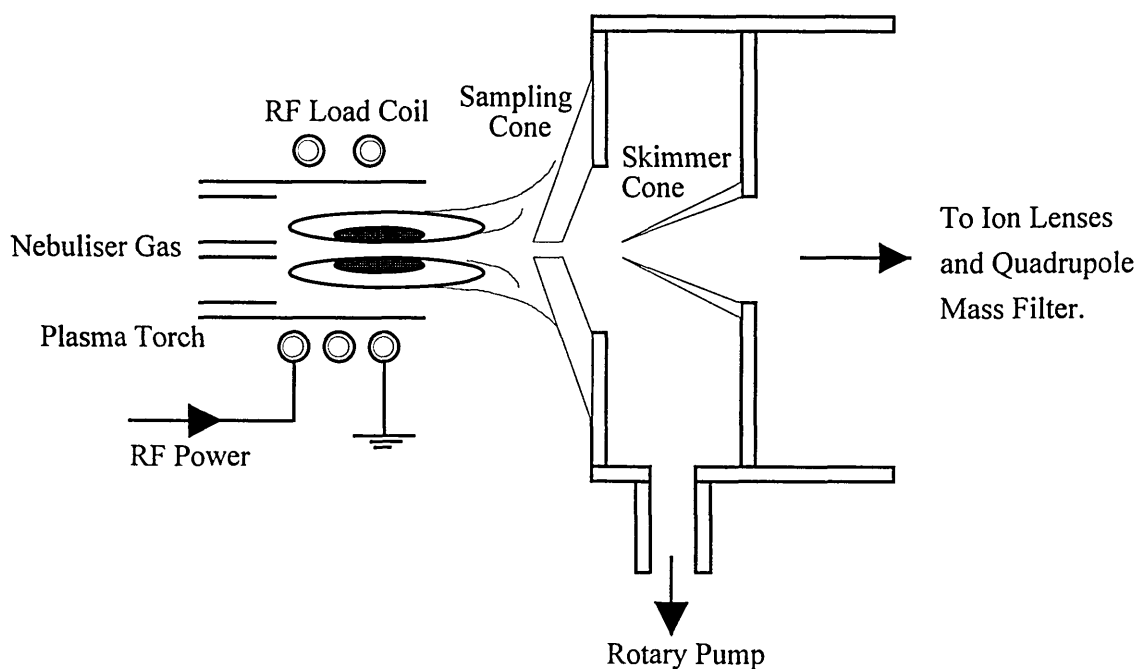

Fig. 13 Representation of the Interface on the PlasmaQuad II+.

The quadrupole consists of four metal rods, parallel to, and equidistant from each other, see Fig. 14.

A positive DC voltage and RF voltages of amplitude U and V , are applied to one pair, while a negative DC voltage and RF voltages of amplitude U and V , but 180° out of phase to the first pair, are applied to the other pair.

The ions are introduced along the axis of the quadrupole at one end at a velocity determined by their mass and energy. The ions are caused to oscillate through the rods

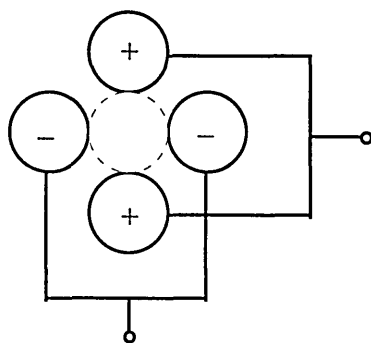

Fig. 14 End-on view of the Quadrupole mass filter.

by the applied RF voltages. By controlling the DC and RF voltages, only ions of a given m/z ratio, will maintain a stable trajectory through the rods. Ions of other m/z ratios, form unstable oscillating projectories, strike the rods and are lost.

The ions leaving the quadrupole are detected using a channeltron electron multiplier. A channeltron electron multiplier is an open glass tube, with a cone at one end. The interior of the tube is coated with a lead oxide semi-conducting material. The ions strike

this material, which results in the ejection of one or more secondary electrons. These electrons, strike the coating, resulting in more secondary electrons being ejected. This continues until as many as 10^8 electrons can be produced by a single ion striking at the entrance to the detector.

Operating conditions were;

Forward power	1350 W
Reflected power	< 10 W
Coolant gas flow	15 L/min
Auxiliary gas flow	1.0 L/min
Carrier gas flow	1.2 L/min
Mass, single ion monitoring	82
Detector mode	Pulse counting
Dwell time	0.5 s

To improve the sensitivity of both the ICP-emission spectrometer and the ICP-mass spectrometer, both systems were coupled to an ultrasonic nebuliser (USN-100, Spectro Analytical). Typical operating conditions were;

Heater temperature	140 °C
Cooler temperature	4 °C
Transducer frequency	1.3 MHz

2.3. Results and Discussion.

2.3.1. Deposition/Elution of Selenium IV and VI on Acidic Alumina.

Initial experiments were concerned with studying the basic deposition/elution of both selenium IV and selenium VI on activated alumina with a view to devising new FI based ICP emission methodology for selenium speciation. Fig. 15 gives the transient

signals obtained for processing standard solutions of selenium(IV) and selenium(VI) (10 mg/L, 250 μ L). It can be seen that, for the two experiments, on injection of sample there was no rise in the plasma background confirming that deposition for both species is essentially quantitative. Significant differences in signal intensity for the elution step were, however, noted, i.e. whereas selenium(VI) was efficiently eluted with a single injection of potassium hydroxide (250 μ l, 2M), a second injection showed no further rise in the plasma background. There was an impaired elution efficiency in the case of selenium(IV), further injections of the KOH showed a rise in the plasma background. The fifth injection of the eluent, KOH, achieved a signal which was 5% above the background signal. The reduced signal strength on elution suggested an increased binding in the case of the selenite species with the alumina as discussed in Chapter 1.

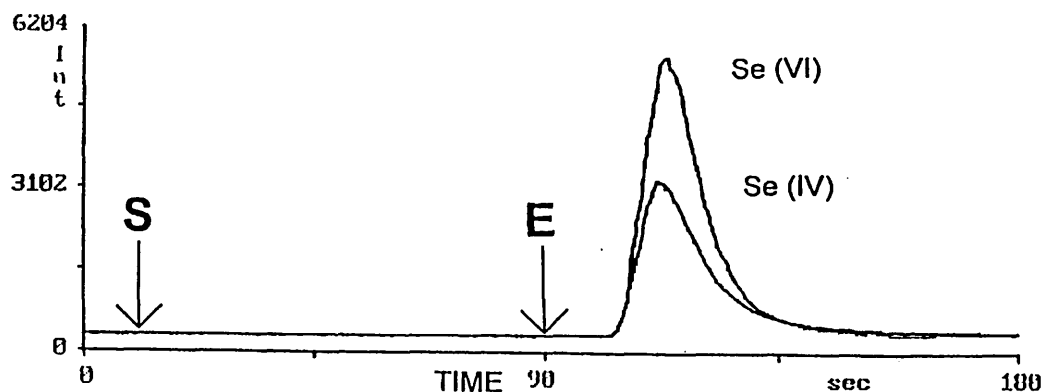

Fig. 15. Separate adsorption/desorption cycles for sequential processing of selenium IV and VI standard solutions by FI-ICP-AES (TJA ICAP 9000). Selenium standard solution, (10 mg/l, 250 μ l). Eluent, KOH (2M, 250 μ l).

In an attempt to exploit differences in elution behaviour, signal response for respective selenium species was studied as a function of eluent strength for both ammonium hydroxide and potassium hydroxide. It was suspected that the possibility may exist whereby relatively weak eluent (NH_4OH) may remove selenium(VI), whereas for selenium(IV) high base strength (KOH) would be necessary. Therefore, using nitric acid (0.01M) as carrier stream, selenium(VI) (10 mg/l, 250 μ l) was deposited on the

microcolumn and subjected to elution with ammonium hydroxide at various concentrations; the experiment was repeated for selenium(IV). The results, shown in Fig. 16, indicate that an ammonium hydroxide concentration of 0.1M was sufficient for elution of the selenium(VI) species. In contrast, selenium(IV) was not effectively eluted with ammonium hydroxide (0.1M).

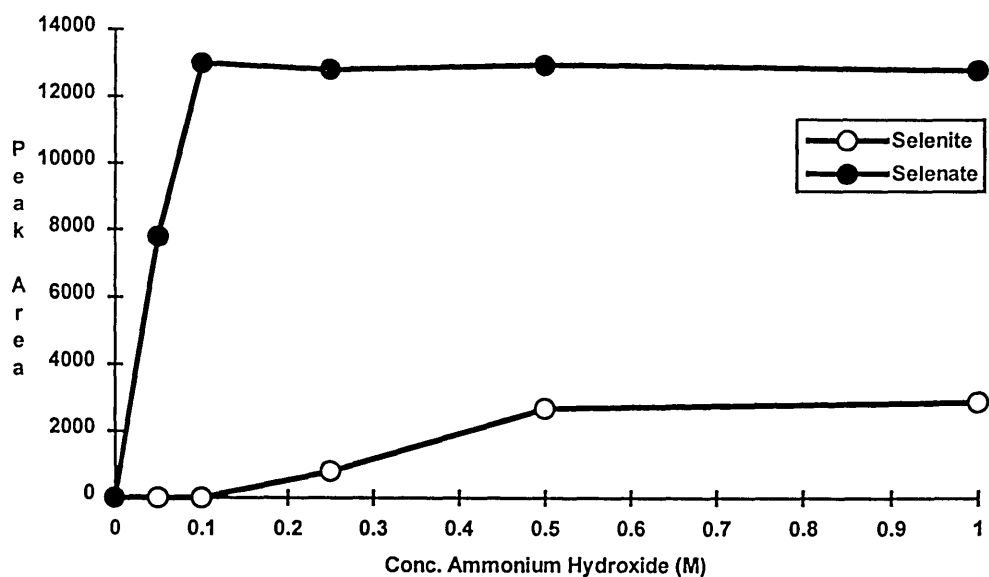

Fig. 16. Raw counts obtained for the elution of selenium IV and VI species with various concentrations of ammonium hydroxide. Selenium species (10 mg/l, 250 μ l).

Experiments were repeated, this time using potassium hydroxide as eluent. A maximum working concentration of 2.0M hydroxide was decided upon, as the alumina undergoes considerable degradation at high alkaline concentrations. Selenium(VI) was removed readily by all concentrations of potassium hydroxide. However, only ~50% of

selenium(IV) was removed with a single injection of eluent. This indicated that there was a relatively high binding strength between the alumina and selenium(IV).

In order, therefore, to provide a speciation measurement capability (see Fig. 17) the following sequence for elution was proposed: injection of ammonium hydroxide (0.1M) followed 90 seconds later by injection of potassium hydroxide (2.0M). Due to the poor elution of selenium(IV) all standards have to be processed in exactly the same way as the samples to achieve a quantitative method. Before further samples can be processed the microcolumn has to be cleaned of any residual selenium(IV), this is achieved by performing five replicate injections of the KOH eluent.

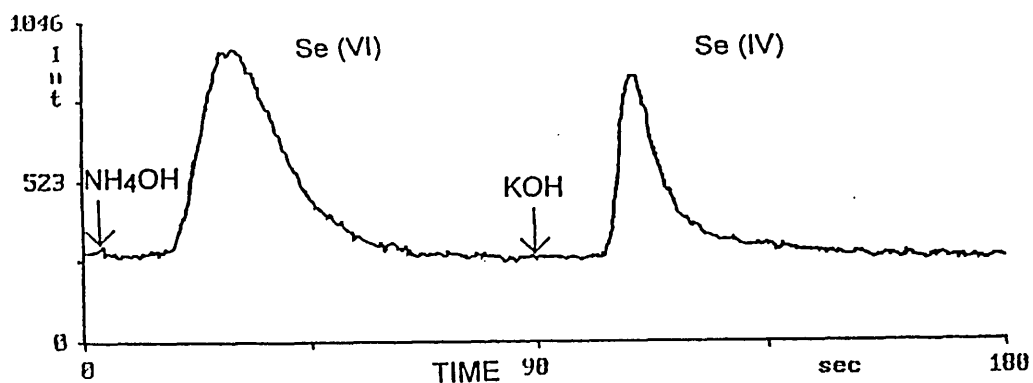

Fig. 17. Signal - time response for sequential elution of Se(VI) and Se(IV) (10 mg/l, 250 μ l) by FI-ICP-AES (TJA ICAP 9000). Eluents, NH₄OH (0.1M, 250 μ l) and KOH (2M, 250 μ l).

To effect preconcentration, samples of increasing volume were processed on the FI system. As shown in Fig. 18, signal intensity increases linearly with sample volume for selenium(VI), the same also applying for selenium(IV). Fig. 19, shows the relative signals for processing selenium(VI) (1.0 mg/l, 1.0 ml) by conventional nebulisation and the flow injection manifold. This shows that a 10 fold increase in maximum signal

intensity for the FI system over steady state signal levels can be observed. Use of a sample volume of 10.0 ml yields a preconcentration factor of ~100 in the case of selenium(VI) and ~50 in the case of selenium(IV). The lower preconcentration factor achieved for selenium(IV) is a direct consequence of the reduced elution efficiency for that species as already discussed.

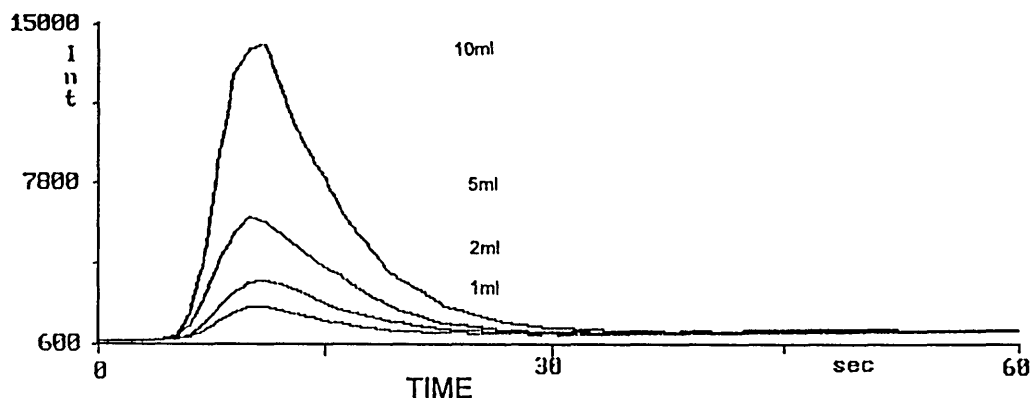

Fig. 18. Sensitivity enhancement for processing increasing volumes of a Se(VI) standard solution by FI-ICP-AES (Spectro, Spectroflame D). Standard solution, Se(VI) (100 $\mu\text{g/l}$). Eluent NH_4OH (2M, 250 μl).

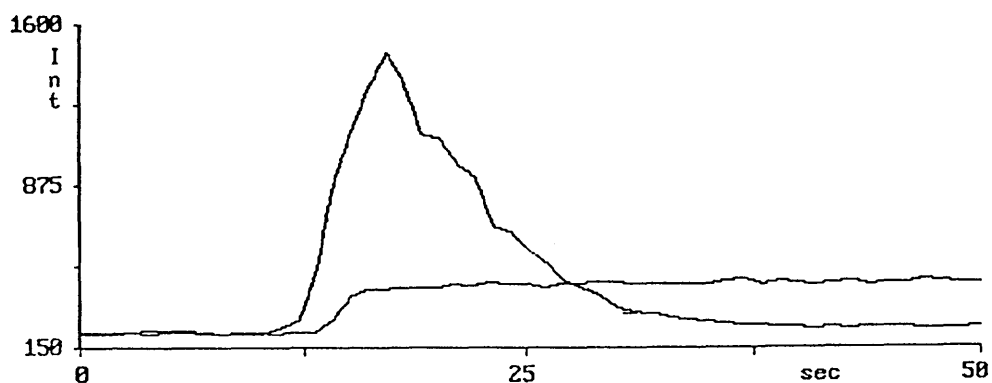

Fig. 19. Signal - time for processing Se(VI) standard solution (1.0 mg/l, 1.0 ml) by (a) conventional nebulisation, and (b) using the alumina microcolumn, eluent NH_4OH (0.1M, 250 μl).

2.3.2. Analytical Performance.

In the next series of experiments, the ability to use the alumina microcolumn separation technique to analyse real mineral water samples is assessed. The effectiveness of the microcolumn to retain selenium species in the presence of other counter ions as well as the system detection limits are calculated.

To perform a calibration study, standard solutions were processed in the FI system and the respective calibration graphs were linear [Se(IV) $y = 98.6x + 126$, regression coefficient = 0.996; Se(VI) $y = 183.8x + 126$, regression coefficient = 0.999] over the range examined (0 - 100 $\mu\text{g/l}$), based on processing 10 ml of sample (see Fig. 20). The limits of detection, calculated as 3 times the standard deviation of the blank, were 1.0 and 4.0 $\mu\text{g/l}$ for selenium(VI) and selenium(IV), respectively.

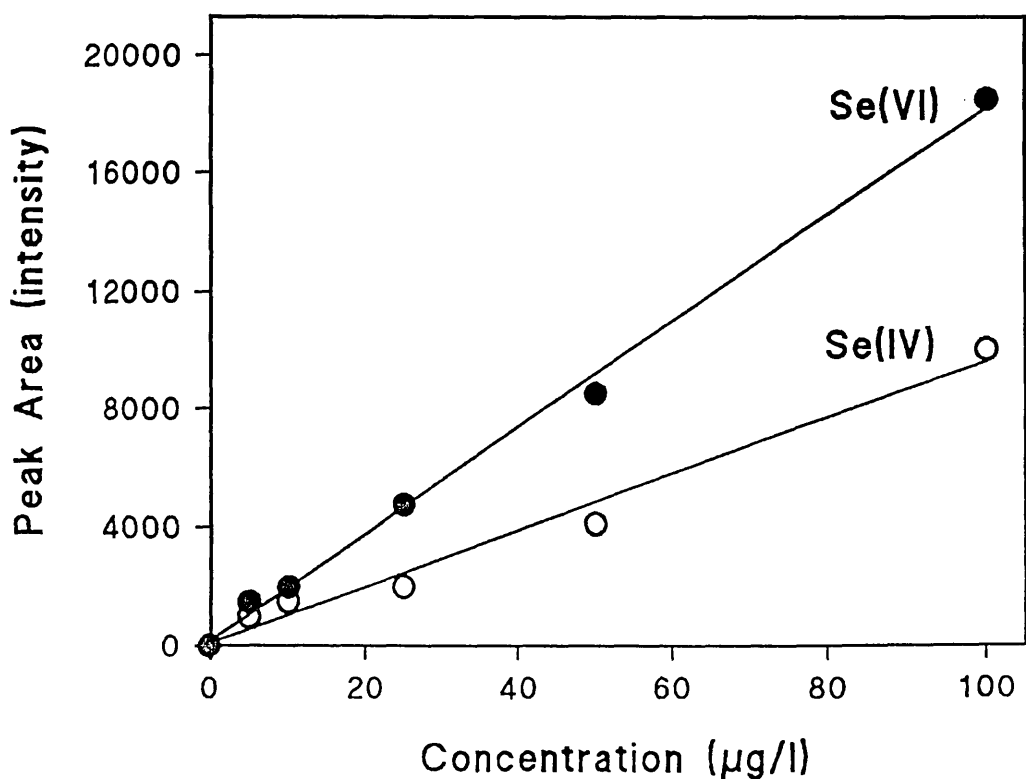

Fig. 20. Calibration graphs for selenium(VI) and selenium(IV), based on processing 10 ml of sample.

To assess the recovery of both selenium species in the presence of other anions, a mineral water was spiked with both selenium species and injected on the microcolumn (100 µg/l, 10ml). Signals were referenced to a mixed standard solution (100 µg/l, 10ml) and the results are shown in Table V.

	Se(VI)		Se(IV)	
	Counts	Recovery	Counts	Recovery
	5534	100	3087	93.3
	5384	97.3	3142	95.0
	4940	89.3	3179	96.1
	4928	89.1	3098	93.7
mean	5197	93.9	3126	94.5
rsd %	5.1		1.17	

Table V. Spike recovery of selenium species (100 µg/l, 10 ml) from mineral water.

As recovery from the mineral water is approximately 100% for both selenium species, this shows that there are no apparent matrix effects from other counter ions such as sulphate, sulphite and phosphate at natural levels. However, a further experiment using aqueous solutions containing a known amount of selenium(VI) (10mg/l) and varying levels of sulphate showed that recovery could be suppressed (see Fig. 21).

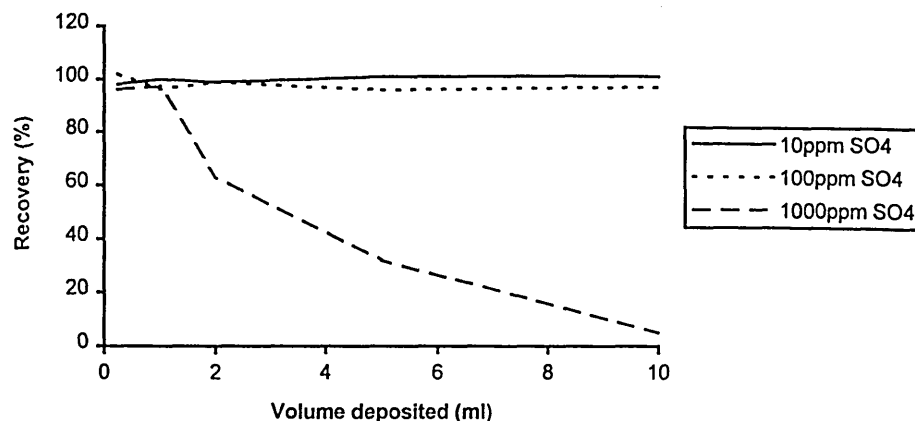

Fig. 21 Suppression caused by elevated levels of marix anions.

Method sensitivity with ICP emission detection being at the $\mu\text{g/l}$ is not sufficient to quantify selenium in the environment which is present at the sub $\mu\text{g/l}$ level, further work was performed with ICP mass spectrometry.

The microcolumn enrichment technique was transferred to ICP mass spectrometry in an attempt to improve method sensitivity and provide measurement capability at the ng/l level. Limits of detection for selenium by ICP mass spectrometry (conventional nebulisation) are in the low $\mu\text{g/l}$ level, being some 100x better than ICP emission spectroscopy, sensitivity improvement of at least 1000 fold is required for application to natural waters. By combining the alumina microcolumn enrichment technique (~100 fold preconcentration) with ultrasonic nebulisation (~10 fold improvement relative to pneumatic nebulisation) measurement at the ng/l level becomes feasible.

An indication of the sensitivity improvement is shown in Fig. 22. The transient signal response corresponds to processing 1 ml selenium(VI) standard solution ($1.0 \mu\text{g/l}$), whereas the steady-state response is for conventional ICP-MS measurement of selenium(VI) ($100 \mu\text{g/l}$). It is clear that almost 100 fold enhancement in signal intensity has been realised (based on matching respective peak height responses and from consideration of respective concentration levels).

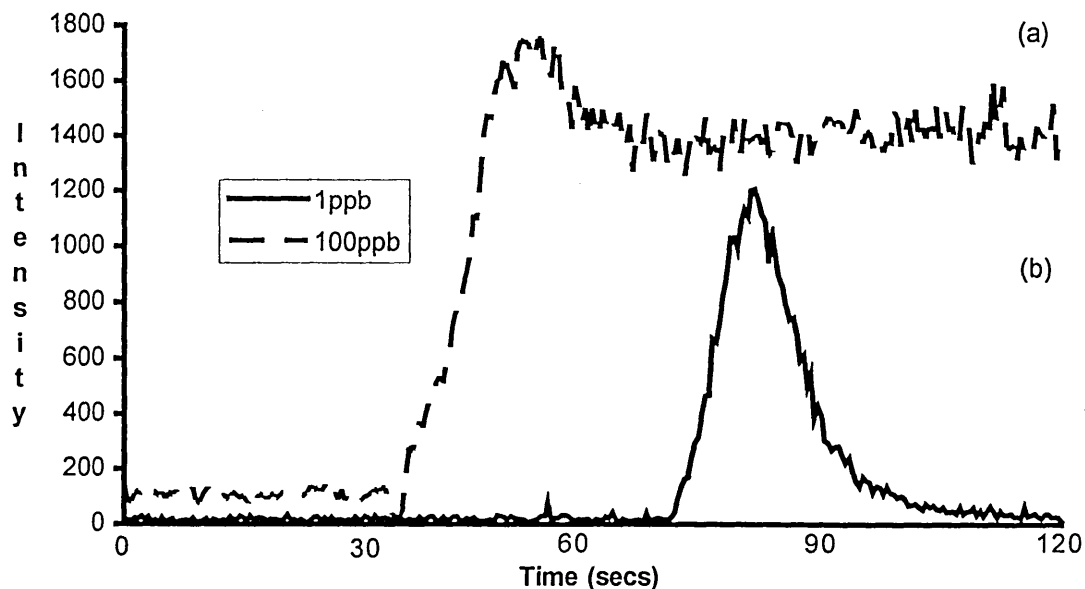

Fig. 22 Signal - time response for (a) conventional sample introduction, 100 $\mu\text{g/l}$ Se(VI) and (b) alumina microcolumn preconcentration with ultrasonic nebulisation of Se(VI), 1 ml of 1 $\mu\text{g/l}$ by FI-ICP-MS. Eluent 2M NH_4OH (250 μl).

Unfortunately, application to selenium(IV) was precluded due to problems associated with the use of potassium hydroxide as eluent. Due to the high eluent concentration (potassium hydroxide, 2.0M) and the high efficiency of the ultrasonic nebuliser, sample loading of the plasma became too high, and resulted in an unstable plasma. A second problem with using high concentrations of potassium hydroxide as eluent, is the formation of the dimer $^{41}\text{K}_2$ in the plasma, which interferes with the selenium isotope at mass 82, see Chapter 1. It was, therefore, decided to proceed only with the determination of selenium(VI) in natural waters, as the ammonium hydroxide eluent produced minimal plasma loading/ interference effects.

Standard solutions of selenium(VI) were processed in the FI system and the calibration graph exhibited linearity [$\text{Se(VI)} y = 96.7x + 121$, regression coefficient = 0.996] over the range examined (0 - 50 ng/l), based on 10 ml sample loading (see Fig. 23). The limit of detection, calculated as 3 times the standard deviation of the blank, was 8 ng/l. The method sensitivity was now considered to be sufficient to quantify selenite in natural waters.

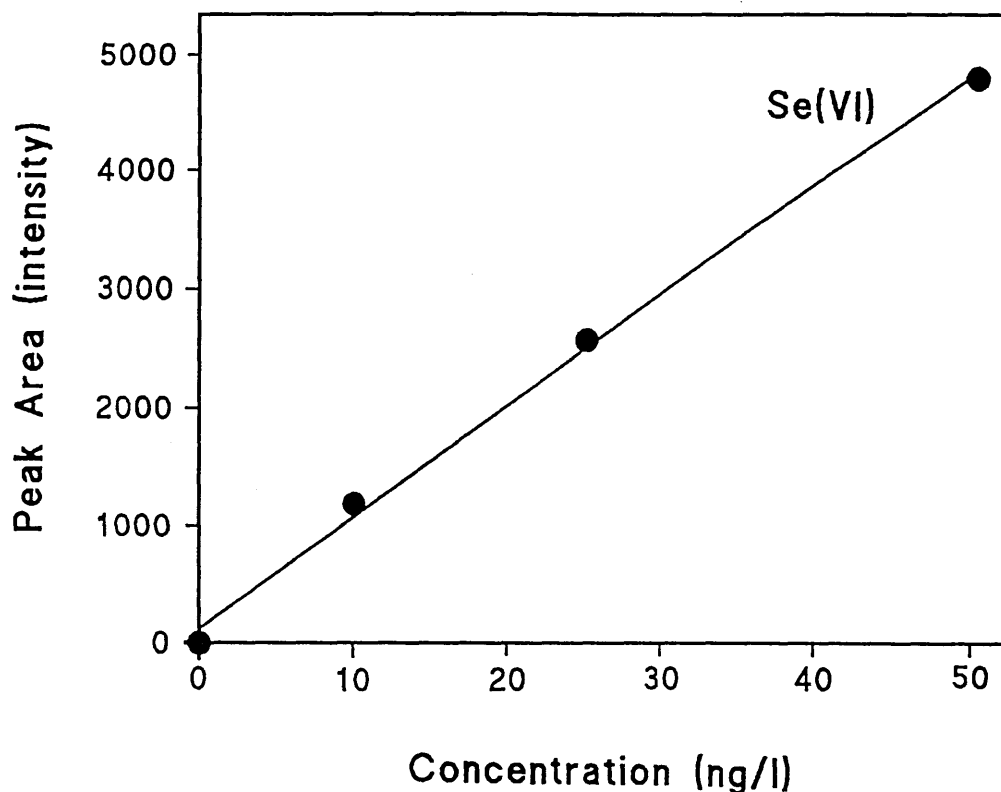

Fig. 23. Calibration graph for Selenium(VI) based on processing 10 ml of sample.

Two bottled mineral waters (10 ml) were processed in the FI system and an injection of ammonium hydroxide (0.1M, 250 μ l) was made to effect elution of selenium(VI). Comparison of the transient response signals for the Buxton and Perrier mineral waters and selenium(VI) standard solutions (25 ng/l, 10 ml) and (500 ng/l, 10 ml) respectively as shown in Fig. 24 and Fig. 25, enables a concentration of 22.6 ± 2.4 ng/l to be calculated for the Buxton mineral water and 402 ± 27 ng/l for the Perrier mineral water. These results shows that the FI system in combination with ICP-MS and ultrasonic nebulisation has the sensitivity required to determine selenium(VI) at natural levels in the ng/l region.

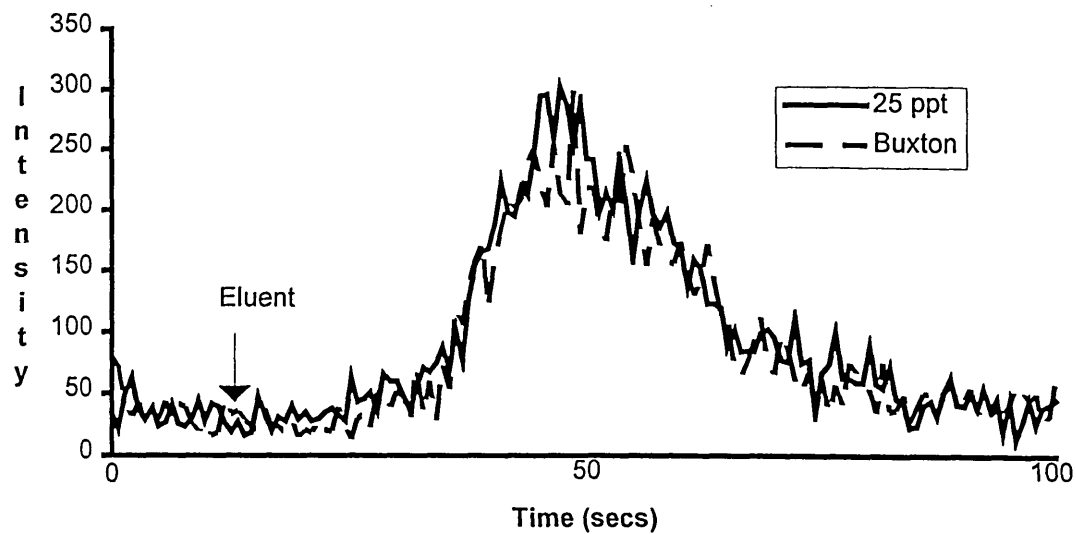

Fig. 24. Signal - time response for selenium(VI) standard solution (25 ng/l) and Buxton mineral water by FI-ICP-MS. Sample volumes, 10ml.

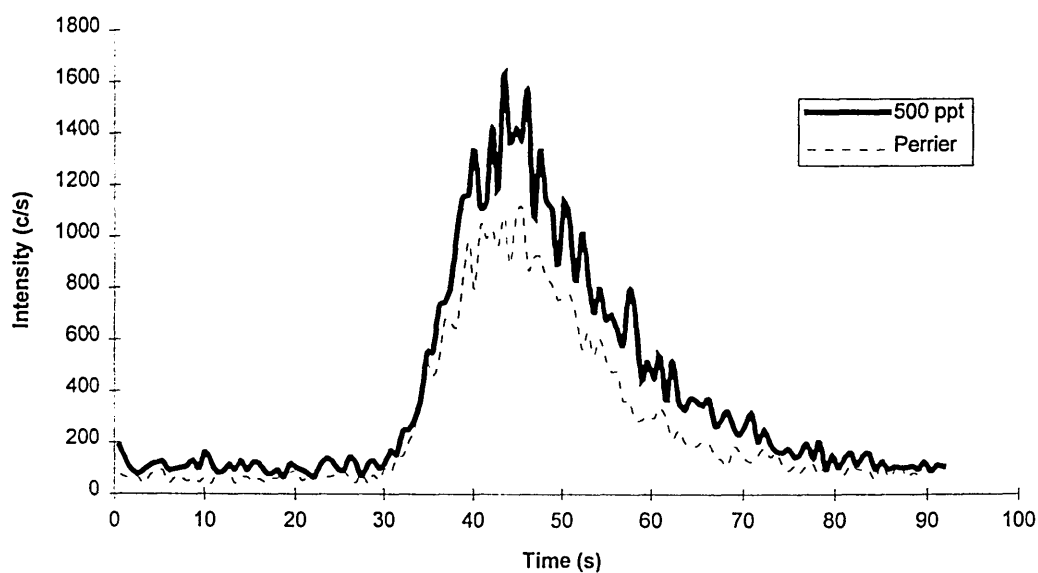

Fig. 25 Signal - time response for selenium(VI) standard solution (500 ng/l) and Perrier mineral water by FI-ICP-MS. Sample volumes, 10ml.

These two samples show the extremely low and differing levels that selenium(VI) can be found in environmental waters.

2.3.3. Deposition/Elution of Selenium Species on Sulphydryl Cotton Fibre.

As the determination of selenium(IV) is precluded because of problems associated with the use of KOH as an eluent. A method is still therefore required to allow the analysis of selenium(IV) at the ng/l level. A study on the interaction of the selenium species with a microcolumn of sulphydryl cotton fibre was made. Initial experiments were therefore concerned with studying the deposition/elution behaviour of selenium IV and VI on sulphydryl cotton fibre. The effect of the carrier pH on the deposition of both selenium species was first undertaken.

Ammonium hydroxide (0.01M) was used as a basic carrier solution, MilliQ water was used as a neutral carrier and nitric acid (0.01M) was used as an acidic carrier. Selenium(IV) (10 mg/l, 250 μ l) was injected into the various carrier solutions onto the microcolumn of sulphydryl cotton fibre. This was followed 60 seconds later by an injection of nitric acid (2M, 250 μ l) as an eluent for the basic and neutral carriers and injection of ammonium hydroxide (2M, 250 μ l) as eluent for the acidic carrier. The peak areas for breakthrough and elution, were compared to those obtained by direct injection of the selenium(IV) species (10 mg/l, 250 μ l) without a microcolumn present in the manifold. The experiments were repeated for selenium(VI) and a comparison of the results can be seen in Table VI.

	Carrier Solution					
	pH > 7		pH ~ 7		pH < 7	
	Breakthrough	Elution	Breakthrough	Elution	Breakthrough	Elution
Selenite	~ 100 %	~ 0 %	~ 100 %	~ 0 %	~ 0 %	~ 100 %
Selenate	~ 100 %	~ 0 %	~ 100 %	~ 0 %	~ 100 %	~ 0 %

Table VI Summary of the deposition/elution data, using sulphydryl cotton fibre.

From the data in Table VI it can be seen that when the carrier is acidic, there are considerable differences in the behaviour of the two selenium species. Selenium(IV) undergoes quantitative deposition onto the sulphydryl cotton fibre (Fig. 26). The selenium(IV) can then be eluted from the microcolumn by injection of ammonium

hydroxide. Selenium(VI) meanwhile is not retained by the sulphhydryl cotton fibre, and passes through the microcolumn. The acidic carrier is required to produce the disulphide bonds necessary for selenium(IV) to bind with the microcolumn material. The disulphide bonds are not produced by the basic or neutral carriers.



However, considerable degradation of the sulphhydryl cotton fibre occurred when using ammonium hydroxide (2.0M), preventing further samples from being processed. The ammonium hydroxide was therefore diluted. An ammonium hydroxide concentration of 0.1M was observed to elute the selenium(IV) efficiently from the microcolumn, while causing minimal damage to the sulphhydryl cotton fibre.

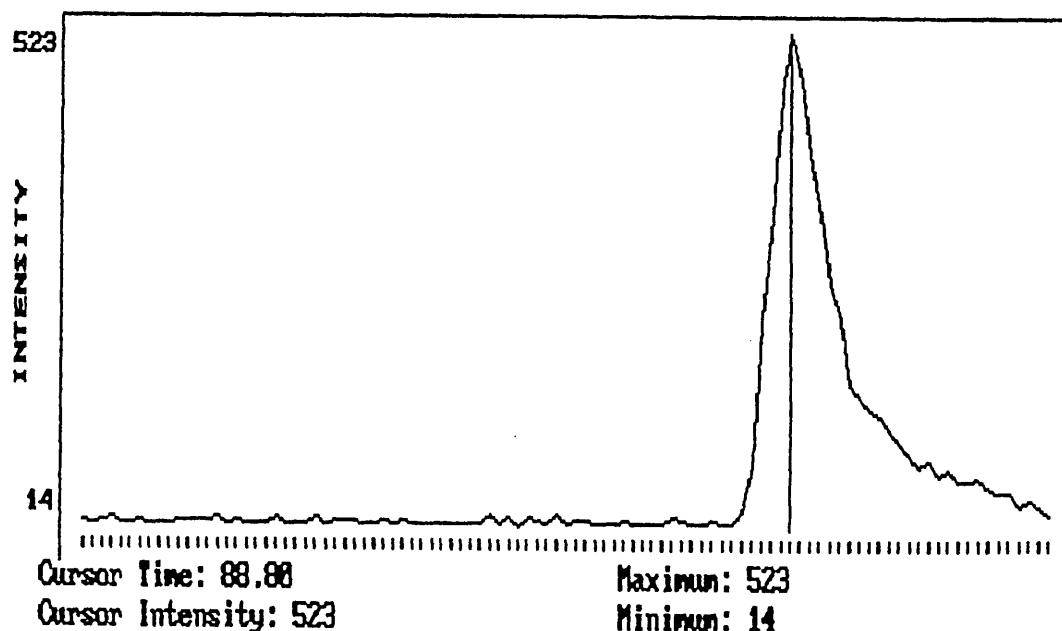

Fig. 26. Adsorption/desorption cycle for processing Se(IV) standard solution (10 mg/l, 250 μ l). Eluent, NH_4OH (0.1M, 250 μ l).

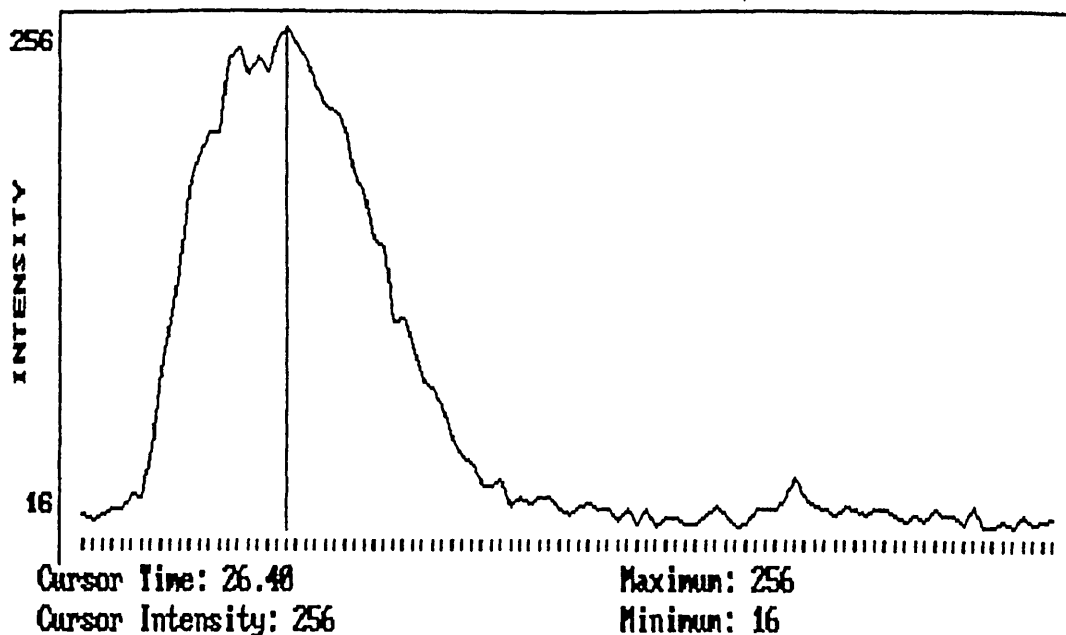

Fig. 27. Adsorption/desorption cycle for processing Se(VI) standard solution, (10 mg/l, 250 μ l). Eluent, NH₄OH (0.1M, 250 μ l).

In order to provide a speciation capability for selenium(IV) and selenium(VI) (see Fig. 28), the following procedure is proposed: injection of sample followed 60 seconds later by injection of ammonium hydroxide (0.1M).

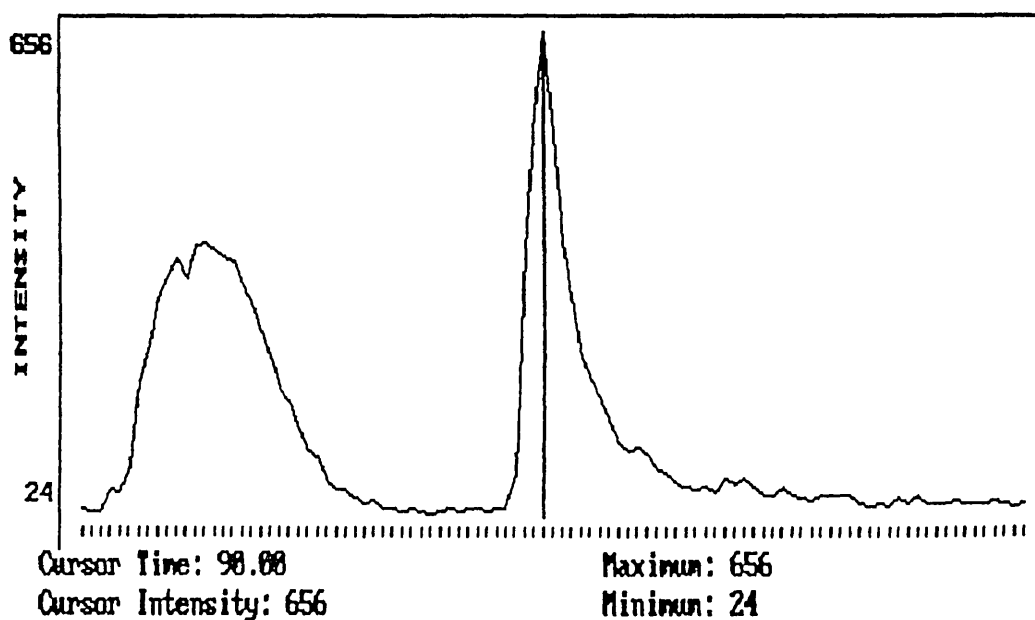

Fig. 28. Signal - time response for sequential injection and elution of Se(VI) and Se(IV). Selenium concentrations, 10 mg/l. Eluent NH₄OH (0.1M, 250 μ l).

The optimum conditions for separating selenium(IV) and selenium(VI) by sulphhydryl cotton fibre are the same as those for determining selenium(VI) by acidic alumina, i.e. carrier solution 0.01M HNO₃ and eluent 0.01M NH₄OH.

2.3.4. Analytical Performance.

The reproducibility for the injection and elution of selenium(IV) from the sulphhydryl cotton fibre, using an ultrasonic nebuliser connected to an ICP-mass spectrometer, is shown in Fig. 29. This indicates that selenium(IV) undergoes quantitative deposition and elution with sulphhydryl cotton fibre. On-line pre-concentration of selenium(IV) was effected by processing increasing sample volumes. As shown in Fig. 30, a seven fold increase in signal intensity for selenium(IV) over selenium(VI) can be achieved by injection of 1 ml of sample. Considerable increases in sensitivity can, therefore, be achieved for selenium(IV) by processing larger volumes of sample.

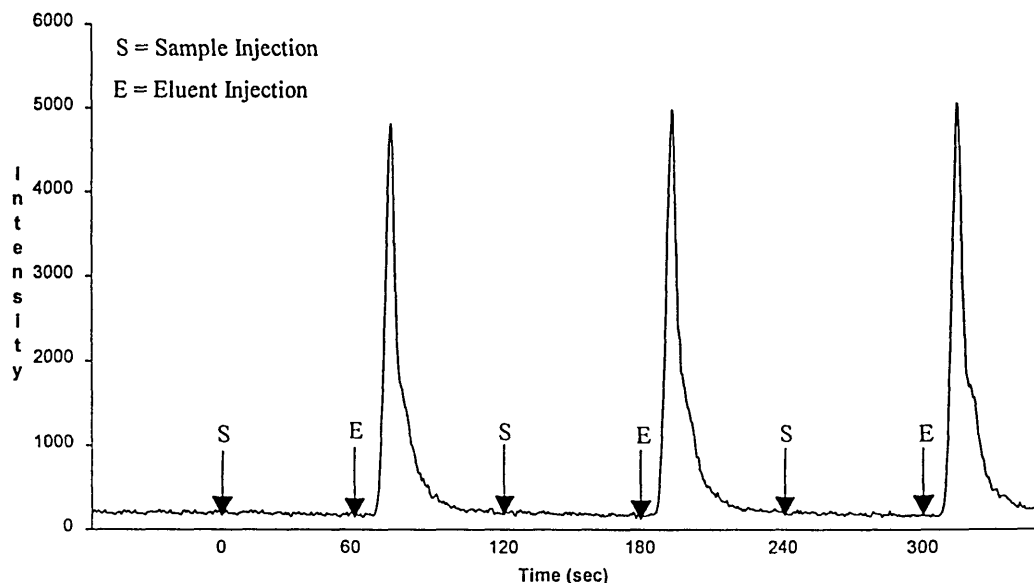

Fig. 29. Repeated sample injections and elutions of selenium(IV) (250 μ l, 50 μ g/l).

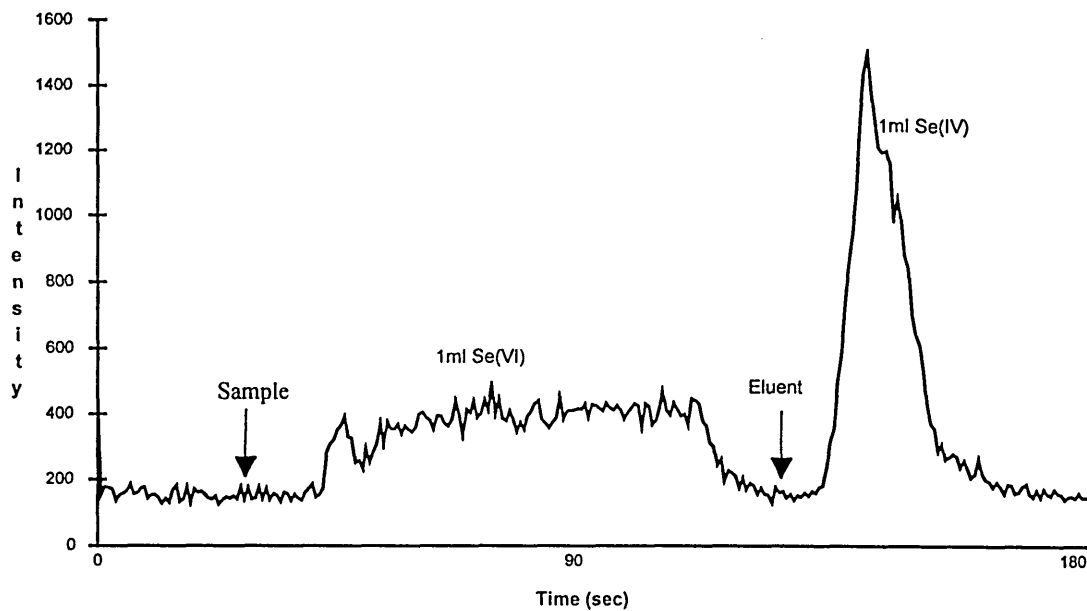

Fig. 30. Signal - time response for injection of mixed selenium standard solution (5 $\mu\text{g/l}$, 1.0 ml). Eluent NH_4OH (0.1M, 250 μl).

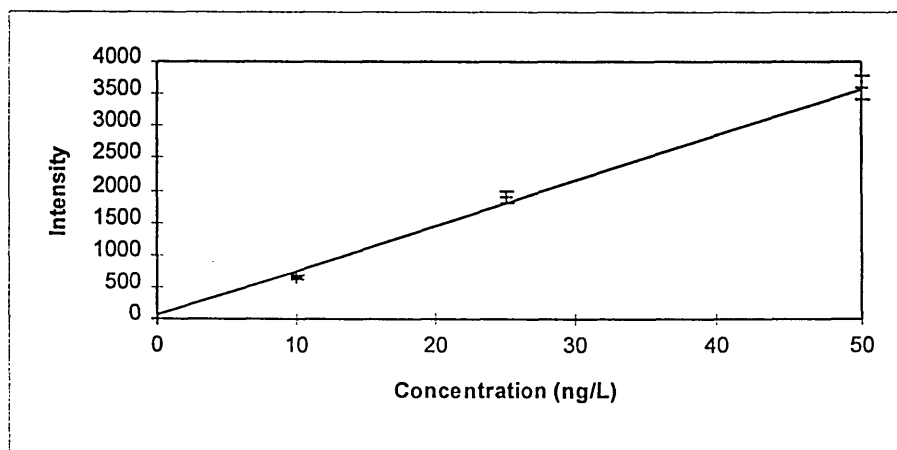

Fig. 31 Calibration graph for selenium(IV) based on processing 10 ml of sample by FI-ICP-MS.

Standard solutions of selenium(IV) were processed in the FI system and the calibration graph exhibited linearity [$\text{Se(IV)} y = 69.1x + 55$, regression coefficient = 0.997] over the

range examined (0 - 50 ng/l), based on 10 ml sample loading. The limit of detection, calculated as 3 times the standard deviation of the blank, was 15 ng/l.

The sulphhydryl cotton fibre microcolumn gave a detection limit for selenium(IV) in the same range as the activated alumina microcolumn gave for selenium(VI). Unfortunately no real samples were analysed using the sulphhydryl microcolumns. This was due to time limitations.

2.4. Conclusions and Further Work.

Flow analysis systems incorporating microcolumns were successfully used for the speciation of selenium in environmental waters. Activated alumina displayed a high affinity for selenium (IV) and (VI) species. Differences in bonding between the two selenium species and the acidic activated alumina allowed the quantitative, selective removal of each species. Detection limits for selenium(IV) and selenium(VI) species were 1 and 4 µg/l, respectively, using ICP emission spectrometry. The poorer detection limit of selenium(IV) is due directly to the reduced elution efficiency for that species.

By combining the activated alumina microcolumn with an ICP mass spectrometer and using ultrasonic nebulisation for sample introduction, the detection limit for selenium(VI) was increased to 8 ng/l. However, analysis for selenium(IV) was precluded due to problems associated with using potassium hydroxide as eluent. The high concentration of KOH used produced plasma loading problems along with an isotopic interference on ^{82}Se due to the formation of $^{41}\text{K}_2$ in the plasma. An eluent is therefore, required for selenium(IV), which does not possess the problems associated with potassium hydroxide. The eluent needs to be of low concentration, to prevent

plasma problems and also contain no elements that can produce an isotopic interference at mass 82.

Lithium hydroxide was used as a possible replacement for potassium hydroxide, for as it has a lower molecular mass, less is required to be dissolved to give equivalent molarity solutions. However, no benefit was seen using lithium hydroxide (0.5M) compared to using ammonium hydroxide (2M). Microwave energy was also used to heat the eluent, in an attempt to aid the elution of the selenium(IV) species. A slight increase in signal was noted, but this was not due to an increase in the amount of selenium(IV) being eluted from the microcolumn, but to an enhancement effect from using microwave energy prior to solution nebulisation.

One way to avoid having to elute selenium(IV) from activated alumina, was to prevent it from undergoing deposition initially. Sulphydryl cotton fibre has shown its ability to be a species selective reagent, retaining only selenium(IV). The research has shown the possibility of using a combination of a microcolumn of sulphydryl cotton fibre with a microcolumn of activated alumina, to preconcentrate and speciate selenium(IV) and selenium(VI).

If the microcolumns were placed in series, the sulphydryl cotton fibre would retain the selenium(IV), preventing its deposition on activated alumina, and so removing the problems associated with the elution of selenium(IV) from activated alumina. The selenium(VI) would pass through the sulphydryl cotton fibre, but, be retained by the activated alumina allowing its preconcentration.

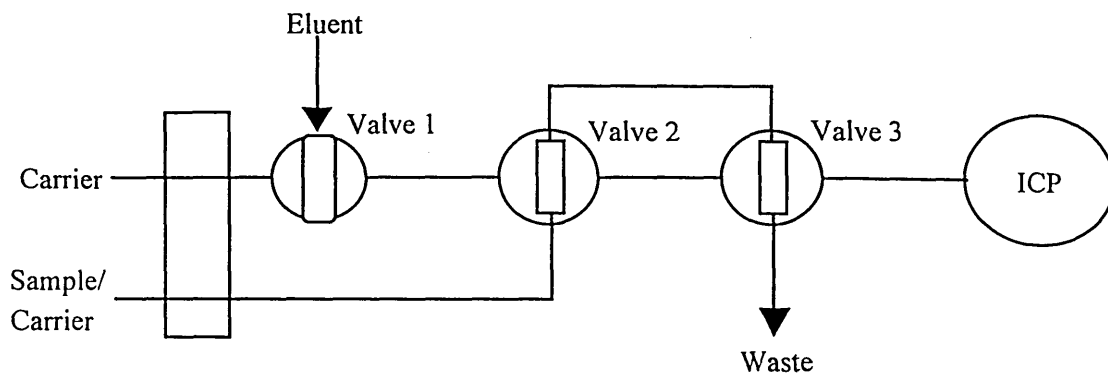

Fig. 32. FI manifold using two columns to selectively retain selenium(IV) and selenium(VI). Valve 1 contains a 250 μ l loop, valve 2 contains a microcolumn of sulphhydryl cotton fibre and valve 3 contains a microcolumn of activated alumina.

In operation, both valves 2 and 3, containing the microcolumns are placed in the load position and sample solutions passed through the microcolumns for specified time periods at a specified flow-rate. This would effect the deposition of selenium(IV) on the sulphhydryl cotton fibre and selenium(VI) on the acidic activated alumina. The sample probe is then placed in the carrier solution. Valve 2, containing the microcolumn of sulphhydryl cotton fibre is then switched to the inject position and an injection of ammonium hydroxide (0.1M) in valve 1, is used to elute the selenium(IV) to the ICP. Valve 2, is then switched back to the load position and valve 3, containing the microcolumn of acidic alumina is then switched to the inject position and a further injection of ammonium hydroxide (0.1M) in valve 1, is used to elute the selenium(VI) to the ICP. A carrier stream of nitric acid (0.01M) is used to maintain the acidity of both columns.

Unfortunately at this time, difficulties were observed in the analysis of selenium(IV) at low ppt levels. The selenium(IV) species was absorbed by the Teflon tubing, while selenium(VI) behaved as would be expected. These problems were not overcome before the research period ended, and so the dual manifold system was not fully characterised.

This problem, due to the absorption effects of Teflon tubing will it is believed become very important in studies at the low ng/l level.

There is still a great deal of work to do to fully understand the effects of selenium on the environment. The ICP-MS technique has shown itself to be a versatile and sensitive detection system for determining selenium species in the environment. However, the high cost of the instrumentation, and the relatively long analysis time for performing speciation analysis makes the cost per sample analysis far too great. For speciation to become a more routine analysis and not remain in the realms of the research laboratory, cheaper and simpler means of performing speciation analysis need to be found. The microcolumn systems are sufficiently cheap to be used to preconcentrate and separate selenium species. They can also be incorporated into automated instruments for handling microcolumns to speed up analysis times. However, cheap and sensitive detection systems based on either molecular fluorescence, atomic fluorescence or electrochemistry will have to be incorporated into a routine speciation analytical instrument.

2.5. References.

- [1] I. Rosenfeld and O. A. Beath, Selenium, Academic Press, New York, 1964.
- [2] S. G. Knott and C. W. R. McKay, *Austral. Vet. J.*, 1959, **35**, 161.
- [3] G. A. Fleming, *Soil Sci.*, 1962, **94**, 28.
- [4] K. H. Schutte, The Biology of Trace Elements, Crosby Lockwood, London, 1964.
- [5] E. J. Underwood, Trace Elements in Human and Animal Nutrition, Academic Press, New York, 1971.
- [6] A. Hamilton and H. L. Hardy, Industrial Toxicology, Publishing Sciences Group, Acton, Mass, 1974.
- [7] P. Pringle, *Brit. J. Derm.*, 1942, **54**, 54.
- [8] K. Schwarz and C. M. Foltz, *J. Amer. Chem. Soc.*, 1957, **79**, 3293.
- [9] J. T. Rotruck *et al.*, *Science*, 1973, **179**, 588.
- [10] M. Mihailovic, *Period. Biol.*, 1984, **86**, 203.
- [11] R. J. Shamberger, *J. Nat. Cancer. Inst.*, 1970, **44**, 931.
- [12] A. C. Griffin and M. M. Jacobs, *Cancer Lett.*, 1977, **3**, 177.
- [13] M. M. Jacobs, B. Jansson and A. C. Griffin, *Cancer Lett.*, 1977, **2**, 133.
- [14] G. N. Schrauzer and D. Ishmael, *Ann. Clin. Lab. Sci.*, 1974, **7**, 411.
- [15] R. J. Shamberger and C. E. Willis, *CRC Crit. Rev. Clin. Lab. Sci.*, 1971, **2**, 211.
- [16] G. N. Schrauzer, D. A. White and C. J. Schneider, *Bioinorg. Chem.*, 1977, **7**, 23.
- [17] R. J. Shamberger, S. A. Tytko and C. E. Willis, *Hemphill D. D. (ed) University of Missouri Press, Columbia 9: 1975*, pp. 15-22.
- [18] X. Chen, G. Yang, J. Chen, X. Chen, Z. Wen and K. Ge, *Biol. Trace. Elem. Res.*, 1980, **2**, 91.
- [19] R. F. Burke, W. N. Pearson, R. J. Wood and F. Viteri, *Amer. J. Clin. Nutr.*, 1967, **20**, 723.
- [20] C. G. Wilber, *Chem. Toxicol.*, 1980, **17**, 171.
- [21] S. E. Raptis, G. Kaiser and G. Tölg, *Fres. J. Anal. Chem.*, 1983, **316**, 105.
- [22] L. Fishbein, *Int. J. Environ. and Anal. Chem.*, 1984, **17**, 113.
- [23] J. M. Harkin, A. Dong and G. Chesters, *Nature*, 1976, **259**, 204.
- [24] H. J. Robberecht and H. A. Deelstra, *Talanta*, 1984, **31**, 497.

- [25] M. Hidiroglou, *Can. J. Animal Sci.*, 1965, **35**, 197.
- [26] A.E. Wheeler, R. A. Zingaro, K. J. Irgolic and N. R. Bottino, *J. Exper. Mar. Bio. Ecol.*, 1982, **57**, 181.
- [27] H. J. Robberecht and R. van Grieken, *Talanta*, 1982, **29**, 823.
- [28] R. Muñoz Olivas, O. F. X. Donard, C. Cámara and P. Quevauviller, *Anal. Chim. Acta*, 1994, **286**, 357.
- [29] K. Takayanagi and G. T. F. Wong, *Anal. Chim. Acta*, 1983, **148**, 262.
- [30] C. J. Cappon, *Water Air Soil Pollut.*, 1987, **60**, 465.
- [31] C. J. Cappon and J. C. Smith, *J. Anal. Toxicol.*, 1978, **2**, 114.
- [32] S. Jiang, W. DeJonghe and F. Adams, *Anal. Chem.*, 1975, **47**, 2279.
- [33] S. C. Apte and A. G. Howard, *J. Anal. At. Spectrosc.*, 1986, **1**, 379.
- [34] D. R. Roden and D. E. Tallman, *Anal. Chem.*, 1982, **54**, 2951.
- [35] G. A. Cutter, *Anal. Chem.*, 1985, **57**, 2951.
- [36] F. Laborda, M. T. C. de Loos-Vollebregt and L. de Galen, *Spectrochim. Acta, Part B*, 1992, **46**, 1089.
- [37] Y. K. Chau, P. T. S. Wong and P. D. Goulden, *Anal. Chem.*, 1975, **47**, 2279.
- [38] K. B. Olsen, D. S. Sklarew and J. C. Evans, *Spectrochim. Acta, Part B*, 1985, **40**, 357.
- [39] S. Jiang, H. Robberecht, F. Adams and D. Van der Berghe, *Toxicol. Environ. Chem.*, 1983, **6**, 191.
- [40] R. J. Kraus, S. J. Foster and H. E. Gauthier, *Biochemistry*, 1983, **22**, 5853.
- [41] H. E. Gauthier, R. J. Kraus and S. J. Foster, *Methods Enzymol.*, 1984, **107**, 582.
- [42] T. Nakahara and N. Kikni, *Spectrochim. Acta, Part B*, 1985, **40**, 21.
- [43] J. Sanz, F. Gallarta, J. Galbán and J. R. Castillo, *Analyst*, 1988, **113**, 1387.
- [44] D. Tanzer and K. G. Heumann, *Anal. Chem.*, 1991, **63**, 1984.
- [45] W. T. Buckley, J. J. Budac, D. V. Godfrey and K. M. Koenig, *Anal. Chem.*, 1992, **64**, 724.
- [46] G. S. Pygen and A. G. Browner, *Appl. Spectrosc.*, 1988, **42**, 508.
- [47] M. J. Powell, D. W. Boomer and R. J. McVicars, *Anal. Chem.*, 1986, **58**, 2864.
- [48] M. McDaniel, A. D. Shendrikar, K. D. Reiszner and P. W. West, *Anal. Chem.*, 1976, **48**, 2240.

- [49] D. H. Cox and A. E. Bibb, *J. Assoc. Off. Anal. Chem.*, 1981, **64**, 265.
- [50] A. D. Meyer, C. Hofer, G. Tölg and G. Knapp, *ibid.*, 1979, **296**, 337.
- [51] K. McLaughlin, D. Dadgar, M. R. Smyth and D. McMaster, *Analyst*, 1990, **115**, 276.
- [52] C. C. Y. Chan and R. S. Sadana, *Anal. Chim. Acta*, 1992, **270**, 231.
- [53] E. Aoyama, K. Akamatsu, T. Nakagawa and H. Tanaka, *Anal. Sci.*, 1991, **7**, 617.
- [54] P. Linares, M. Dolores Luque de Castro and M. Varcargel, *Analyst*, 1986, **111**, 1405.
- [55] K. Folkers and J. Shovel, U. S. Patent 2 573 702, 1901.
- [56] F. Umland, *Zeitschrift für Electrochemie*, 1956, **60**, 711.
- [57] I. G. Cook, C. W. McLeod, P. J. Worsfold, J. E. Davies and J. Queay, *Spectrochim. Acta, Part B*, 1985, **40**, 57.
- [58] A. G. Cox, I. G. Cook and C. W. McLeod, *Analyst*, 1985, **110**, 331.
- [59] I. G. Cook, C. W. McLeod and P. J. Worsfold, *Anal. Proc.*, 1986, **23**, 5.
- [60] A. G. Cox, C. W. McLeod, D. L. Miles and J. M. Cook, *J. Anal. At. Spectrom.*, 1987, **2**, 553.
- [61] C. W. McLeod, Y. Zhang, I. G. Cook, A. G. Cox, A. R. Date and Y. Y. Cheung, *J. of Res. of the Nat. Bureau of Stand.*, 1988, **93**, 462.
- [62] S. Ahmad, R. C. Murthy and S. V. Chandra, *Analyst*, 1990, **115**, 287.
- [63] P. P. Coetzee, I. Talijaard and H. De Beer, *Fres. J. Anal. Chem.*, 1990, **336**, 201.
- [64] A. G. Cox and C. W. McLeod, *Mikrochim. Acta*, 1992, **109**, 161.
- [65] K. Yamada, C. W. McLeod, O. Kujirai and H. Okochi, *J. Anal. At. Spectrom.*, 1992, **7**, 661.
- [66] M. Sperling, S. Xu and B. Welz, *Anal. Chem.*, 1992, **64**, 3101.
- [67] P. Smichowski, M. Beatriz de la Calle Guntinas and C. Cámara, *Fres. J. Anal. Chem.*, 1994, **348**, 380.
- [68] S. Dadfarnia and C. W. McLeod, *Appl. Spectrosc.*, 1994, **48**, 1331.
- [69] Y. Zhang, A. G. Cox and C. W. McLeod, *Unpublished Work*.
- [70] J. Dai and C. Zhou, *Lihua Jianyan, Huaxue Fence*, 1991, **27**, 232.
- [71] B. Yi, *Fenxi Huaxue*, 1987, **15**, 637.
- [72] J. Yao and F. Li, *Fenxi Huaxue*, 1987, **15**, 1114.

[73] W. Jian and C. W. McLeod, *Anal. Proc.*, 1991, **28**, 293.

[74] W. Jian, M. L. Mena, C. W. McLeod and J. Rollins, *Fres. J. Anal. Chem.*, In Press.

3. SPECIATION VIA LASER ABLATION-ICP-MASS SPECTROMETRY.	86
3.1. Introduction.	87
3.2. Experimental	96
3.2.1. Laser Focusing.	98
3.3. Results and Discussion.	100
3.3.1. Optimisation of Laser Ablation.	100
3.3.2. One-Dimensional Electrophoretograms	103
3.3.3. Mapping.	109
3.3. Conclusions.	113
3.4. References.	115

3.1. Introduction.

The ability to analyse samples directly in the solid is an extremely powerful tool for the analyst. Lasers facilitate the analysis of micro-features on a sample and additionally the ability to perform bulk analysis. The main question mark with the direct analysis of solids is the ability to obtain quantitative results, this is due to the limited number of solid standards available. Although many standards are available for the analysis of metals such as steels, this analysis is normally carried out by spark-ablation spectrometry. The areas of analytical chemistry where laser ablation excels is the analysis of rocks and minerals. However as few standards are available, this severely limits applied laser ablation development.

Agarose gels are by their very nature homogeneous, and can easily be doped with known concentrations of an analyte. This makes them an ideal medium for use as external calibrants for the analysis of gel electrophoretograms.

Cross immunoelectrophoresis is an extremely powerful technique for the separation of proteins. To determine analytes bound to the proteins, currently requires the use of radioactive isotopes of the element of interest. This technique, autoradiography, can take up to 2 weeks per gel. By using laser ablation for the in situ analysis of the gels, the need to use radioactive isotopes is removed, dramatically improving safety and applicability. The turnaround time for the analysis of a gel is also dramatically improved with a gel being 'mapped' in 8 hours compared to 2 weeks by autoradiography.

The combination of gel electrophoresis with laser ablation - ICP-MS, is potentially an extremely powerful technique for performing speciation studies on metallo-protein compounds. Initial studies will centre around optimising laser conditions for the ablation of the gel, these studies will then progress onto one-dimensional electrophoretograms. These initial studies were used to characterise the system and to calculate the detection levels achievable. Such studies concluded that it would be necessary to use spiked serums in the crossed immunoelectrophoresis, to be able to detect any analyte.

Trace metallo-enzyme complexes play an essential role in biological systems, with the metal either as an active component or in a structural role. At elevated concentrations however, these metals can become toxic^[1]. To identify and quantify the biological compound to which a trace metal is bound, as well as quantifying the amount of trace element bound, entails first the separation, identification and quantification of the biological components, followed by the quantitative determination of the trace metal in each biological component. Crossed immunoelectrophoresis can be used to separate biological proteins allowing their identification and quantification^[2]. The use of radioactive isotopes of the analyte in question allows the quantification of the bound trace metal to be calculated^[3]. These experiments, however, cannot be carried out *in vitro*, they require the use of radioactive sources and analysis can take up to two weeks. There is therefore, a need to reduce analysis times and remove the use of radioactive sources for safety reasons.

Laser ablation offers an excellent means of performing localised analysis on solid materials. If the analyte species present in a sample have been separated on a solid medium, laser ablation offers the perfect means of analysing the separated species *in situ*. Electrophoresis being a separation technique which separates analyte species on a solid medium, is thus compatible with laser ablation.

Electrophoresis was first developed as an analytical technique by Arne Tiseleius in 1930's^[4], and for this pioneering work, he received the Nobel prize in 1948. Electrophoresis involves the separation of charged species on the basis of their movement under the influence of an applied electric field. The species under study move in a liquid medium supported by an inert solid substance, such as paper or a gel. The liquid serves as the conducting medium for the electric current generated by the application of an external voltage to the system. The parameters which control the migration of the species through the gel are, the viscosity of the medium, the strength of the applied voltage, the net charge of the species, and the size and shape of the species, as shown in Fig. 1.

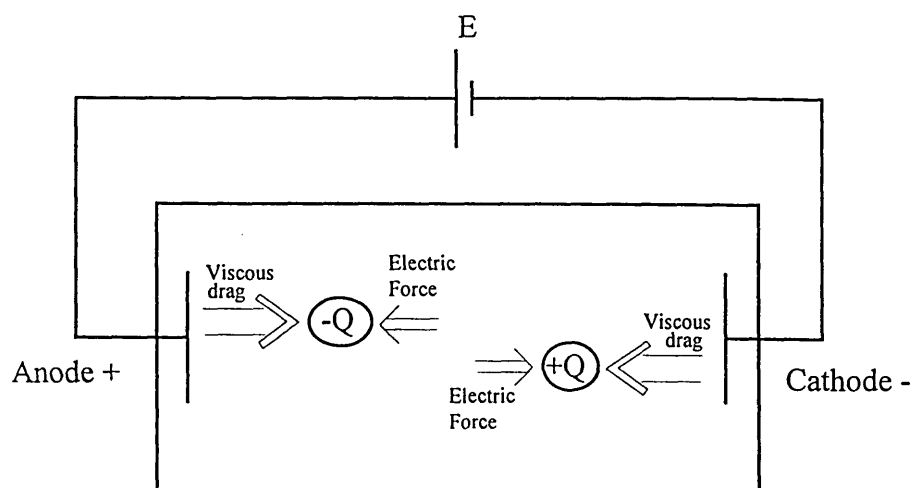

Fig. 1. Forces acting on molecules of charge, Q , in an electric field, E .

A protein consists of one or more polypeptide chains twisted, wound, and folded upon themselves to form a macromolecule with a definite three-dimensional shape or conformation. A protein's function depends on its unique conformation, which is a consequence of the specific linear sequence of the amino acids that make up the polypeptide chain. Many proteins are globular (roughly spherical), while others are fibrous in shape. In the complex conformation of a protein, three levels of architecture, known as primary, secondary and tertiary structure can be seen. The primary structure of a protein is its unique sequence of amino acids. The secondary structure is a result of hydrogen bonds at regular intervals along the polypeptide backbone. This causes the segments of the polypeptide chain to be repeatedly coiled or folded in patterns that contribute to the protein's overall conformation. Superimposed onto the secondary structure, is a protein's tertiary structure, consisting of irregular contortions from bonding between the side chains of the various amino acids.

Fig. 2. Diagram showing an amino acid, how they join together to form proteins, and the dependence of charge on the pH.

The proteins are separated from one another, into discrete zones. These zones are stabilised by the use of a gel supporting medium. The sample is applied to the gel, in a well made in the gel. During the run the components are separated by the applied current, and are kept separated by the gel. Agarose gel is generally used as the support medium for protein analysis, as its pore size is determined by the concentration of agarose present. The higher the concentration of the agarose the smaller the pore size. As proteins can be very large molecules, a large pore size is required, so a low concentration of agarose is used. The pore size of a dilute agarose gel is relatively large compared to the pore size of other gels, such as of polyacrylamide gel, making agarose gel a suitable support material for proteins.

Immunoelectrophoresis^[5], is a combination of electrophoresis and immunology. These methods are based on the ability of the protein of interest to elicit the production of an antibody, i.e. to behave as an antigen. This antibody will react only with the protein which elicited it. In crossed immunoelectrophoresis, the proteins (antigens) are first separated by zone electrophoresis. The separated proteins are cut from the first gel and placed along the bottom of a second gel containing a known amount of antibody. Electrophoresis is again performed. For the antigen-antibody system, there is an optimum point at which a precipitate will be observed, called precipitin. The precipitin appears as curved peaks. When the precipitin formation is complete, the gel is washed to remove non-precipitated materials. Precipitin can be determined simply by looking at the electrophoretogram under good light, however, the sensitivity of detection can be poor.

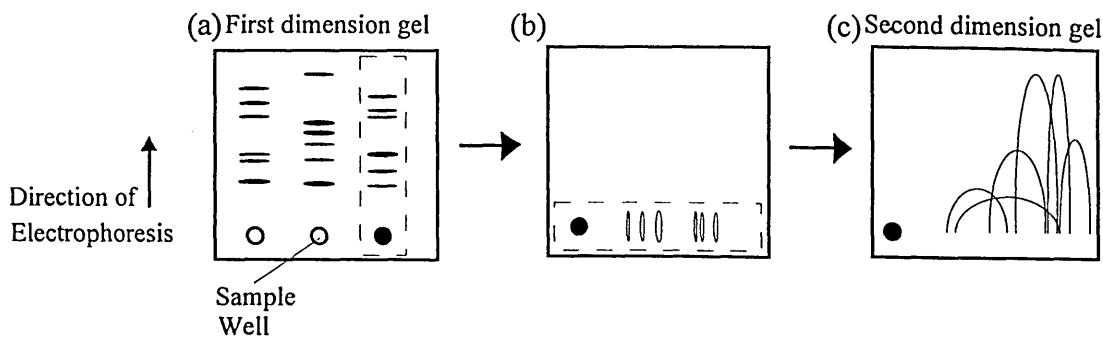

Fig. 3. Processes involved in crossed immunoelectrophoresis, (a) Proteins separated in normal zone electrophoresis, (b) one of the separations is cut from gel (a) and placed on gel (b) which contains the antibodies for many proteins, (c) a potential is again applied resulting in peaks of precipitin.

There are various conventional systems for determining the separated components of a sample. Initially, electrophoretograms were photographed under UV light, with the zones showing as dark bands. Changes in the refractive index also allows the visualisation of the separated components. The most popular detection system however, is to stain or dye the separated components, then to detect their positions by absorption or fluorescence. The most common stain for the determination of proteins is Coomassie Brilliant Blue, which binds to basic groups on proteins.

As well as optical methods of detection, radiochemical methods of detection are widely used. Before electrophoresis, the analyte is labelled with a radioactive isotope. After electrophoresis, the support media, is cut into pieces and the radioactivity of each piece measured by liquid scintillation. Alternatively, the technique of autoradiography can be used. This permits the detection of the radiation in each of the separated components, without the need to cut the support media. Autoradiography is extremely useful for gels of large pore size, such as dilute agarose gels, as these cannot often be cut easily for liquid scintillation counting. The electrophoretogram is dried and placed in a photographic cassette against a piece of X-ray film. The electrophoretogram is left for

up to two weeks. When the film is developed, the distribution of radioactivity in the sample shows up as black areas on a light background. Although this system is applied successfully, it is very time consuming, and also assumes that the radioactive analyte behaves in the same way as the non-radioactive analyte.

Laser ablation offers the capability to measure the local concentration of analyte on the gel substrate. In combination with ICP-mass spectrometry it offers a rapid and sensitive system, removing the need to use radioactive sources, and reducing analysis times from 2 weeks to one day.

When lasers were first introduced in 1960^[6], it was soon realised by analytical chemists that they could provide an excellent means of sampling small amounts of solid material. Initially, the plasma induced by the laser shot was measured directly by optical and mass spectrometric systems^[7,8]. However, more recently, the laser sampling has been separated from the spectrometric detection.

Laser ablation offers the capability to sample most materials, regardless of whether they are conducting, non-conducting, organic, inorganic, solid or powdered. Laser ablation also offers the capability to perform localised analysis, allowing microanalysis and spatially resolved studies to be performed.

Many different types of laser have been utilised to perform laser ablation studies. The first laser to be used was the ruby laser^[9], which showed the ability of laser ablation as a sampling technique to perform qualitative and semi-quantitative analysis with spectrometric methods. The ruby laser, however, has a poor shot to shot reproducibility, can only be operated at repetition rates less than 1 Hz and does not interact with some glasses and polymers. The Nd:YAG laser, which radiates at 1064 nm, is absorbed by most materials. They can also be run at medium (1-10 Hz) to high (1-5 kHz) repetition rates and can produce good shot to shot reproducibility. The Nd:YAG laser is the most common laser used in connection with ICP spectroscopy^[10,11]. Other lasers, such as gaseous carbon dioxide lasers^[12] and excimer lasers, such as the xenon chloride laser^[13] have been used to sample materials for ICP. But these lasers, along with the nitrogen

laser, tended to be used for microprobe analysis, because of the small spot sizes possible^[14,15], recently however, microprobe analysis has been taken over by frequency quadrupled Nd:YAG systems.

The principle of laser action (light amplification by stimulated emission of radiation) is depicted in Fig. 4.

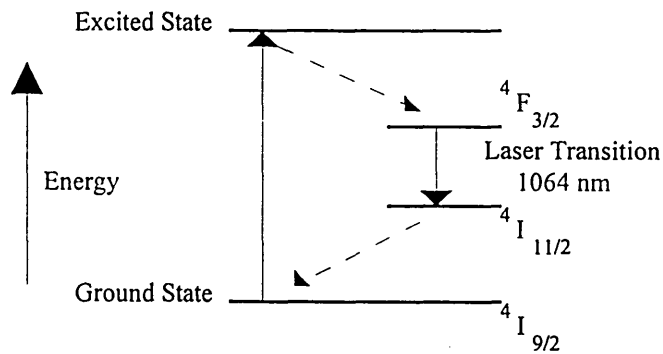

Fig. 4. Transition levels of the lasing energy.

Electrons in the excitation medium are optically excited by a pulsed flashlamp to high energy levels. The excited electrons rapidly decay to the upper lasing transition level, $4F_{3/2}$, where they can remain for a relatively long period ($\sim 230 \mu\text{s}$). Photons, produced by random, spontaneous emission at 1064 nm, impinge on these excited electrons and result in the release of two photons of the same energy travelling in the same direction and in phase. The mirrors at either end of a resonant cavity, pass the light back and forth, causing further stimulated emission. A Q-switch acts as a high speed shutter, it is closed initially, to allow the build-up of a large population of excited electrons at the $4F_{3/2}$ level. When the maximum population is achieved, $\sim 220 \mu\text{s}$ from the start of the flash lamp, the Q-switch is opened and the energy is released as a single giant pulse. The pulse width is less than 10 ns, and the peak optical power is of the order of megawatts. Laser radiation is monochromatic, unidirectional, intense, and coherent (same phase and polarisation).

The lasing energy is directed to the sample by a mirror and focused with a lens. The lasing energy is focused onto the surface of the gel. The gel in the vicinity of the laser spot is heated very rapidly. The lasing energy is absorbed by the gel, which causes the gel to be vaporised. The heated gel leaves the surface as vapour, droplets or as superheated streams. These are swept to the ICP-mass spectrometer by a stream of argon gas, to the injector tube of the ICP torch.

Although an advantage of laser ablation is the capability to perform localised analysis, a disadvantage is that bulk analysis is not easily performed on non-homogenous samples. Samples can be homogenised prior to laser ablation, but this detracts from the premise that one of the major advantages of laser ablation is that it requires minimal sample pretreatment. The lack of suitable solid standards, restricts the use of laser ablation for bulk, quantitative analysis. Laser ablation currently also suffers from poor relative standard deviations of between 5 to 10%. This is commonly due to variation in shot to shot laser output power, but may also be due to variations in coupling efficiency. Standards are therefore required, whose matrix closely matches the sample matrix. The standard is also required to be homogenous, even on the microscale.

There have been recent indications of the damaging effects of nickel on the body^[16], with many cases of allergenic behaviour to nickel being associated with the wearing of costume jewellery, and the effects of prosthesis made from a nickel alloy^[17]. It was, therefore, initially hoped to analyse nickel-protein complexes by the combination of crossed immunoelectrophoresis with laser ablation ICP-mass spectrometry. This, however, proved unfeasible. The ICP-mass spectrometer interface uses nickel cones, making the background for nickel relatively high, leading to poor limits of detection. Platinum cones can be used instead of nickel, but these are very expensive and could not be obtained. It was therefore decided to carry out the feasibility studies of crossed immunoelectrophoresis in combination with laser ablation ICP-mass spectrometry on cobalt-protein complexes. Cobalt was chosen as it is mono-isotopic, and as such is a very sensitive system.

Cobalt is an essential trace element, forming an integral part of vitamin B12, but it is also a known allergenic and possible carcinogen at elevated concentrations^[18]. Cobalt is used in the manufacture of alloys. Skin contact with the powders or effluents of industrial processes involving cobalt can cause dermatitis^[19]. Ingestion of cobalt salts results in nausea and vomiting because of local irritation to gastric walls. The acetate, carbonate and chloride of cobalt were used in the brewing of beer as foam stabilisers. However, in the 1960's in Quebec City, Canada, the occurrence of cardiomyopathy was suddenly seen in over fifty patients. This was traced to beers being drunk that contained ten times more cobalt than was usual^[20,21]. Cobalt was observed as an essential element over sixty years ago, when it was shown that giving cobalt to sheep and cattle prevented two debilitating diseases^[22]. In 1948, it was discovered that the antipernicious anaemia factor in liver was a compound containing 4% cobalt^[23,24]. This compound is now known as vitamin B12.

The crossed immunoelectrophoresis discussed herein was performed by Jeanet Nielsen, from the National Institute of Occupational Health, in Denmark. After the electrophoresis was performed, the gels were cut into 3 pieces and transferred to glass plates (3 cm x 4 cm). The glass plates with the gels were then pressed, washed and dried. The dried gels were transferred from Denmark to Sheffield, where the laser ablation studies were then performed. Before the crossed immunoelectrophoresis gels were analysed, initial studies were carried out on both gels containing known amounts of analyte and one dimensional electrophoresis gels to optimise the sensitivity of the system.

3.2. Experimental

Gels through which cobalt-protein complexes had been separated using crossed immunoelectrophoresis were obtained from J. Neilson from the Institute for Occupational Health in Denmark. Agarose (Indubiose A37) was from L'Industrie Biologique, France. Rabbit antibodies against human serum proteins were supplied by Dakopatts A/S (Glostrup, Denmark). Monospecific rabbit antibodies against human α -2-macroglobin, α -1-antitrypsin, haptoglobin, prealbumin and albumin were from

Dakopatts A/S. A stock solution of Co (CoCl_2 in water) supplied by Merck (Darmstadt, Germany) was used for spiking serum samples and preparing enriched gels for calibration.

Pooled human serum (approximately 1500 individuals) was received from Bisperjæg Hospital, (Copenhagen, Denmark) and aliquots were enriched with Co at the level of 700mg/L. MilliQ water was used in all sample dilutions. Unless stated otherwise, spiking of samples was performed immediately before application to the agarose gels.

The electrophoresis equipment used was from Procon Aps (Uldum, Denmark; model PP3 89) in combination with a Hetofrig Thermostat (Heto Lab Equipment A/S, Birkerød, Denmark).

The gels were cut into three pieces and placed onto glass plates (3 cm x 4 cm). The local cobalt concentration in the gel was then determined using laser-ablation inductively coupled plasma mass spectrometry. A schematic of the system set-up is shown in Fig. 5.

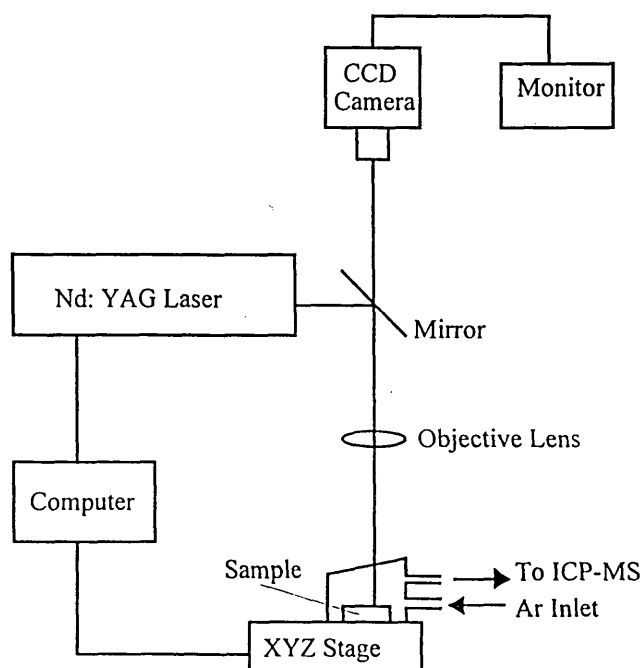

Fig. 5 Schematic of the LaserLab II.

A VG Elemental LaserLab 2 (VG Elemental, UK) Nd:YAG laser was used in this study. It is a pulsed, solid state laser with an output of 1064 nm, a variable repetition rate up to 10 Hz, and is Q-switched. The key components of the laser are a Neodymium doped Yttrium Aluminium Garnet (Nd:YAG) excitation medium, a xenon flashlamp, a Q-switch and a resonant cavity, see Fig. 6.

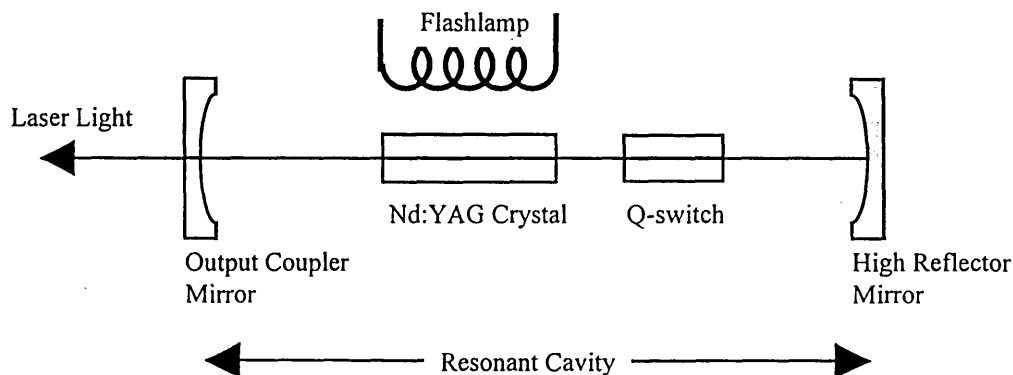

Fig. 6 Schematic of the Spectron Nd:YAG laser.

3.2.1. Laser Focusing.

The glass plates holding the electrophoresis gels are placed onto a sample holder on top of an XYZ stage. As the gels are transparent, they do not absorb the laser energy efficiently. Movement of the sample in the Z direction allowed the laser light to be focused or defocused onto the sample. Therefore to increase the amount of sample being ablated, the sample was moved 8 mm upwards, out of focus. This results in a larger spot size, reducing the resolution of the system, but increasing the sensitivity, since more analyte is ablated, see Fig. 7.

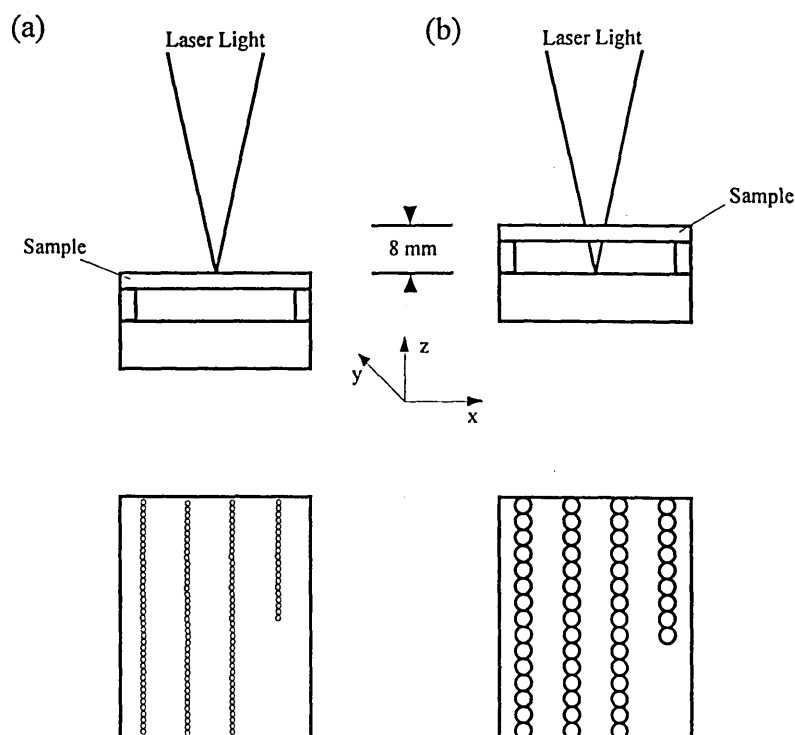

Fig. 7 Representation of ablation patterns when (a) laser light in focus, (b) laser light 8 mm out of focus.

The X-Y positions to be ablated were entered into the computer, the computer then controlled the laser shot, the position, and the data collection. Cobalt is monoisotopic, therefore the ICP-mass spectrometer, described in section 2.1.2. monitored the atomic mass unit 59 Daltons. The raw data obtained for cobalt for each shot was entered into a spreadsheet (Microsoft Excel 3.0) to create a 'map' of the cobalt concentration on the gel. This was compared to a radiogram of a similar electrophoretogram.

Typical laser operating conditions were;

Laser mode	Q Switched
Flash lamp voltage	800 V
Beam focus position	8 mm de-focused
Laser energy	300 mJ per pulse
Number of shots per location	3
Shot frequency	10 Hz
Carrier gas flow	0.8 L/min

The laser was coupled to an ICP-mass spectrometer, PlasmaQuad II+ (VG Elemental, Winsford UK), typical operating parameters were;

Forward power	1350 W
Reflected power	< 10 W
Coolant gas flow	15 L/min
Auxiliary gas flow	1.0 L/min
Carrier gas flow	0.8 L/min
Mass, single ion monitoring	59
Detector mode	pulse counting
Dwell time	0.5 s

3.3. Results and Discussion.

3.3.1. Optimisation of Laser Ablation.

Preliminary studies were carried out to assess the possible sensitivity of laser ablation ICP-mass spectrometry of electrophoretic gels. The dried gel can virtually be thought of as being 2 dimensional, i.e. having no depth. Therefore the volume of sample being ablated is not important, the area of sample ablated, controls the amount of sample transported to the ICP. Therefore, for small spot sizes, i.e. at the focal point of the laser, the maximum amount of sample capable of being ablated is small. To improve the sensitivity of the system, a greater area of sample needs to be ablated. By defocusing the laser energy, it is possible to increase the spot size, and therefore, ablate a larger area of gel. Due to the poor interaction of the i.r. energy with the gel, the laser power was set at its maximum level and fired at a gel prepared containing a known amount of cobalt. The xyz-stage was then moved in the z-direction (upwards), and in the x-direction, and the laser was fired again. This process was repeated and the results are shown in Fig. 8.

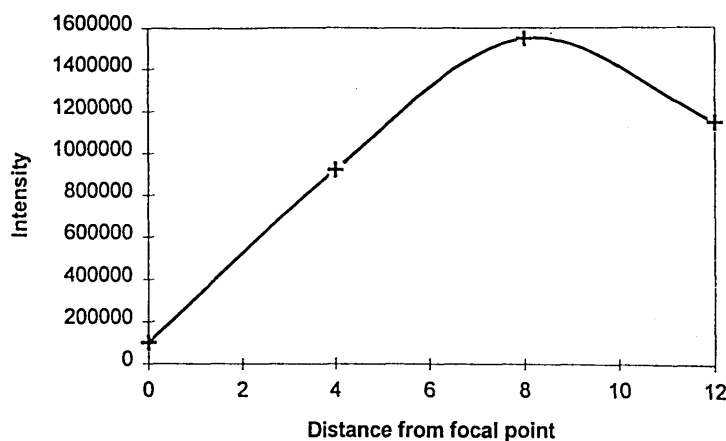

Fig. 8. Effect of laser focus on sensitivity (Agarose gel spiked with 700 mg/L Co).

The results showed that a sample position 8 mm above the focal point of the laser is the optimum position for ablating the gels. When the laser is defocused, the amount of energy acting on the gel is reduced. The energy is further reduced as the gel is transparent, and so the interaction of the laser energy and the gel is poor. Therefore, above 8 mm, the laser energy acting on the gel is too low to cause efficient ablation. Although defocusing the laser gives a dramatic improvement in sensitivity, the larger ablation areas lead to a reduction in the resolution of the system. The ablation spot is approximately 0.75 mm in diameter, compared to an ablation spot of ~0.2 mm diameter when the laser is in focus.

A major weakness of laser ablation is the poor shot to shot precision usually achieved when ablating samples. This is often due not only to changes in the laser output power, but also the non-homogeneity of samples on the microscale, however very homogenous gels can be prepared. A gel was prepared with MilliQ water containing cobalt (700 mg/L). This gel was placed in the ablation chamber and ablated. The *xyz*-stage was randomly moved in the *xy*-directions and the laser fired again. This was repeated a further 3 times to check the shot to shot reproducibility. The entire process was repeated again, this time firing the laser twice at each ablation point at a frequency of 10 Hz. The

process was repeated again, firing the laser three times at each ablation point at a frequency of 10 Hz, the results from this experiment are shown in Fig. 9.

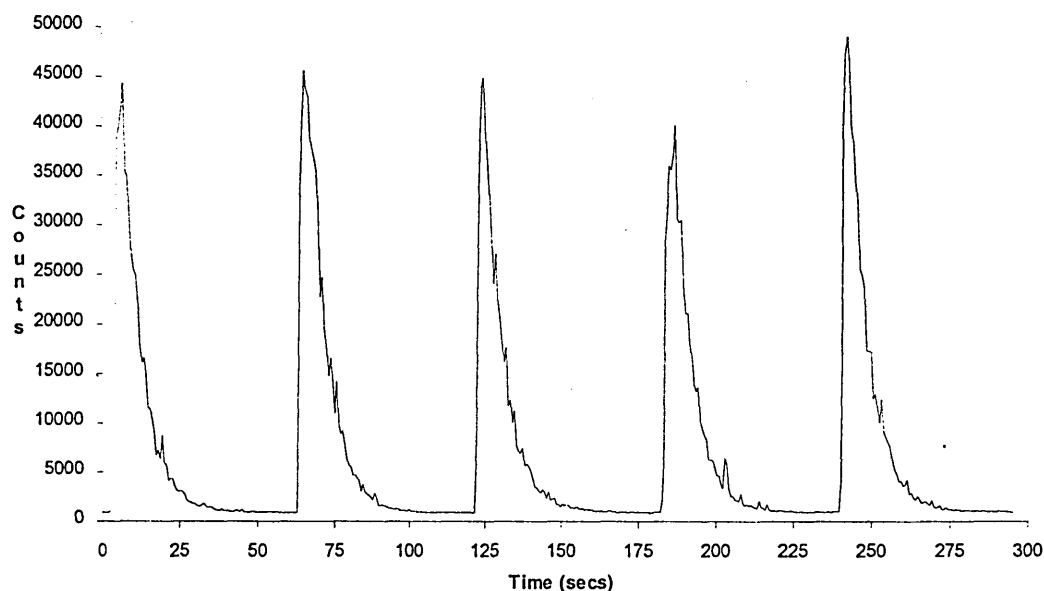

Fig. 9. Diagram indicates the shot to shot reproducibility of the laser, firing 3x per point at random points on the gel. Monitoring the Co-69 mass.

One transient signal is observed for each ablation point. This is because the total firing time, 0.3 seconds, is very small compared to the residence time of the signal. Firing the laser 3 times at each ablation spot gave extremely good shot to shot reproducibility (% rsd 6.1). This removed the variability caused by changes in the laser output power. Therefore the laser was fired 3 times at maximum power at a frequency of 10 Hz in all the further studies.

The gels used in the previous studies were prepared in exactly the same way as the gel on which the crossed immunoelectrophoresis was performed. These gels, therefore, have the same matrix as the electrophoretic gels. As they can be prepared containing a known amount of cobalt, they can be used as standards to give an indication of the cobalt

concentration in the electrophoretograms. Therefore, three gels were prepared with MilliQ water containing a known concentration of cobalt (7, 70, 700 mg/l). These gels were ablated at five random points and the peak areas used to create a calibration graph.

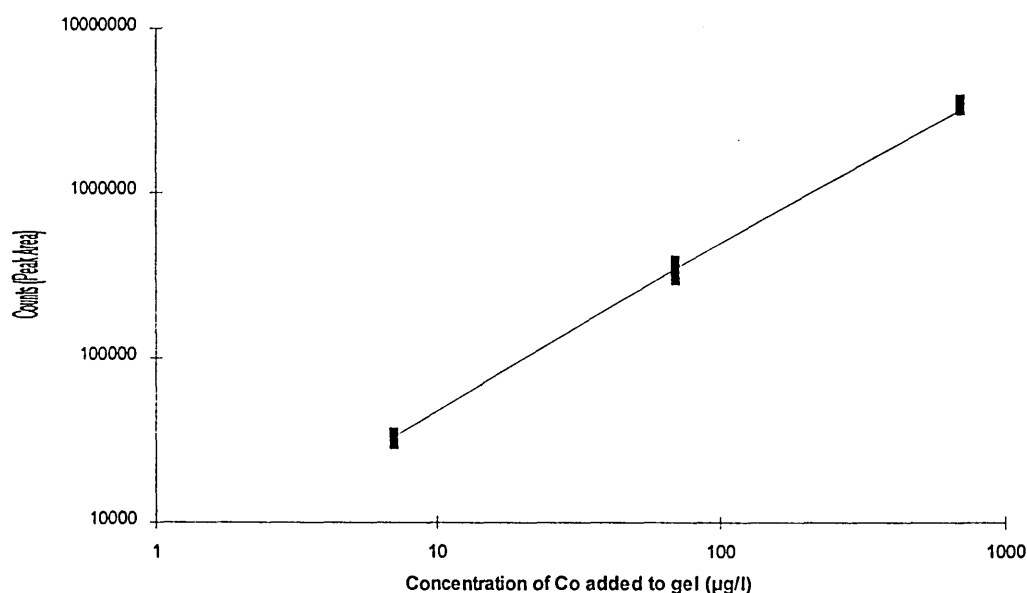

Fig. 10. Calibration graph showing counts obtained from ablating gels containing a known amount of cobalt. (n=5)

The response achieved for the gels, shows the possibility of using these gels as standards for the electrophoretograms. The limit of detection for cobalt, taken as 3 times the standard deviation of a gel prepared with MilliQ water containing no added cobalt was 8.2 µg/ml (equivalent to 0.075 µg/cm²). In absolute terms, this corresponds to a mass of 0.29 ng Co.

3.3.2. One-Dimensional Electrophoretograms

The next stage of the work was to analyse the first dimension electrophoretograms. The cobalt concentration in the first dimension gels is higher than in the second dimension gels. Although the total amount of cobalt present is the same, the area over which it is spread is much greater in the second dimension gel, diluting the cobalt concentration. It

was therefore necessary to discover if the cobalt could be detected in the first dimension gel before proceeding.

Five samples were prepared to characterise the system. These samples were:

Sample 1 a blank gel, prepared with MilliQ water containing no cobalt. This sample was used as the reagent blank. This would indicate if the agarose gel contributed to the signal obtained for cobalt. No electrophoresis was performed on this sample.

Sample 2 a standard gel prepared with MilliQ water containing a 700 mg/L of cobalt. This sample was to be used as a standard to give an indication of the amount of cobalt in the electrophoretograms-. No electrophoresis was performed on this sample.

Sample 3 a blank gel prepared with MilliQ water containing no added cobalt. A well was punched at one end to receive samples. An aliquot (6 μ l) of human serum was added to the well. Electrophoresis was then performed on this sample. This sample was used to see if cobalt could be detected in a non enriched serum sample.

Sample 4 a blank gel with a well punched at one end. An aliquot (6 μ l) of human serum spiked with cobalt to give a final cobalt concentration of 12 mmol/l serum was added to the well. Electrophoresis was then performed on this sample.

Sample 5 a blank gel with a well punched at one end. An aliquot (6 μ l) of cobalt (12 mmol/l) was added to the well. Electrophoresis was then performed on this sample. This was to observe what happens to any free cobalt during the electrophoresis procedure. Any free cobalt may contribute to the signal from the ablations.

The gels were received on glass plates (3 cm x 2 cm). Each glass plate was placed in the ablation chamber individually. Sample 1 was ablated first using the optimised conditions from the preliminary studies. Each ablation spot was chosen by moving the xyz-stage randomly in the x- and y-directions. This was repeated for sample 2.

For sample 3, the sample was moved until the sample well was directly under the laser. After the first ablation, the sample was moved 1 mm in the x-direction. This was repeated until the opposite edge of the glass plate was reached. The sample was then moved back 1.5 cm in the x-direction and then in the y-direction until the edge of the glass plate was under the laser. The laser was fired and the sample then moved 1 mm in the y-direction. This was repeated until the opposite edge of the glass plate was reached. The ablation pattern produced is represented in Fig. 11.

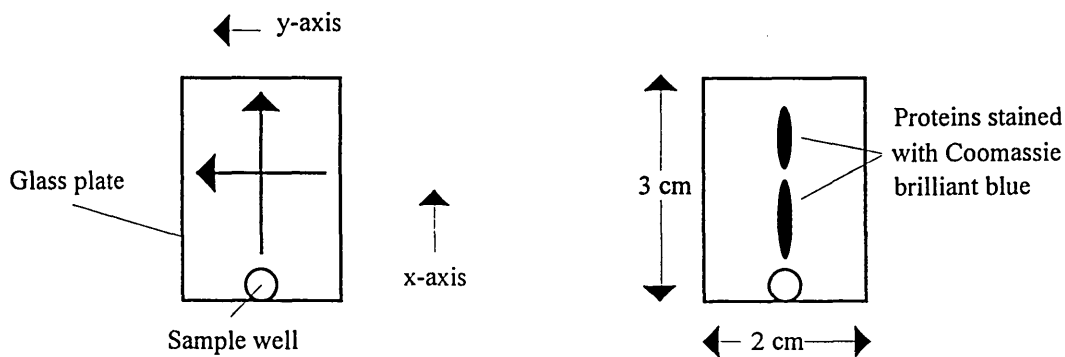

Fig. 11. Diagram indicating the lines and direction of the ablations on samples 3, 4 and 5 and a representation of the electrophoretogram for sample 3 stained with Coomassie Brilliant Blue.

The ablations were performed in these positions as Coomassie Brilliant Blue staining of an electrophoretogram prepared in the same way as sample 3, had shown that the

proteins were situated in a narrow band above the sample well. Typical signals for these 5 samples are shown in Fig. 12.

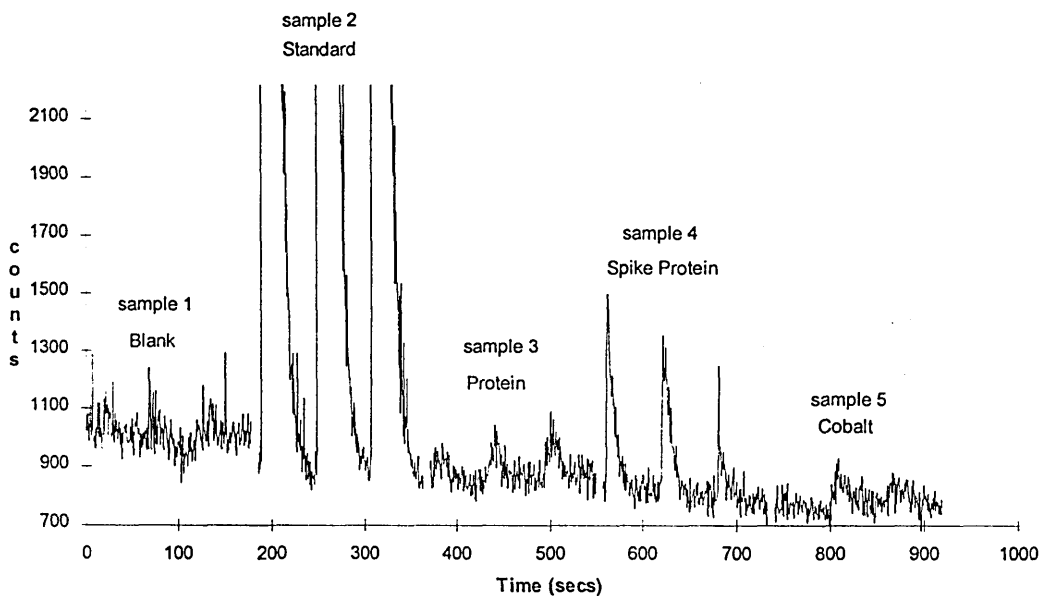

Fig. 12. Typical signals from each sample for 3 ablations.

A gradual reduction in the background level can be observed for ablation of the samples 1 to 5. The time scale on the x -axis however, is for comparison of the signals only. The samples were placed in the ablation cell and analysed one at a time. The time between samples is approximately 1 hour. During this time the sensitivity of the ICP-mass spectrometer has drifted downwards. This was common for ICP-mass spectrometers which have to be either frequently reoptimised or used with an internal standard to compensate for the drift. However, the ICP-mass spectrometer was not optimised between samples to prevent any risk of contamination to the samples. Therefore, the reduction in signal must be taken into consideration when comparing the signal from one sample to another sample. A commonly used practise in laser ablation ICP-MS is the monitoring of a matrix ion, such as $^{12}\text{C}^+$, however, in this case this was not possible as the data was collected in single ion monitoring mode.

The signals obtained from sample 1, showed little or no rise in the plasma background for each ablation. This indicates that there is very little or no cobalt present in the agarose gel. The ablation of sample 2 resulted in very large and precise peaks. These however were not used as a standard due to their relatively large size compared to the small signals obtained for the electrophoretograms. Very small signals can be seen for the ablation of the proteins separated by electrophoresis in sample 3. This indicates that the cobalt present in the proteins can be detected in the first dimension gel. However, the signals are so small that it is unlikely that the system will be sensitive enough to detect the cobalt present in proteins on the second dimension gel. The signals for sample 4 of the proteins spiked with extra cobalt and separated by electrophoresis, are, as would be expected, larger than the signals obtained from sample 3. The cobalt concentration present in the second dimension gel of sample 4, may be sufficient to be used for crossed immunoelectrophoresis. Although sample 5 contained the same amount of cobalt as sample 4, only extremely small or no changes in the plasma background were observed. This indicates that most of the free cobalt ions, pass straight through the agarose gel to the cathode and are 'lost'.

The peak areas from the full ablation pattern of samples 3, 4 and 5 were entered into a spreadsheet and graphs created to show the location of cobalt on the glass plate. These results given in Fig. 13.

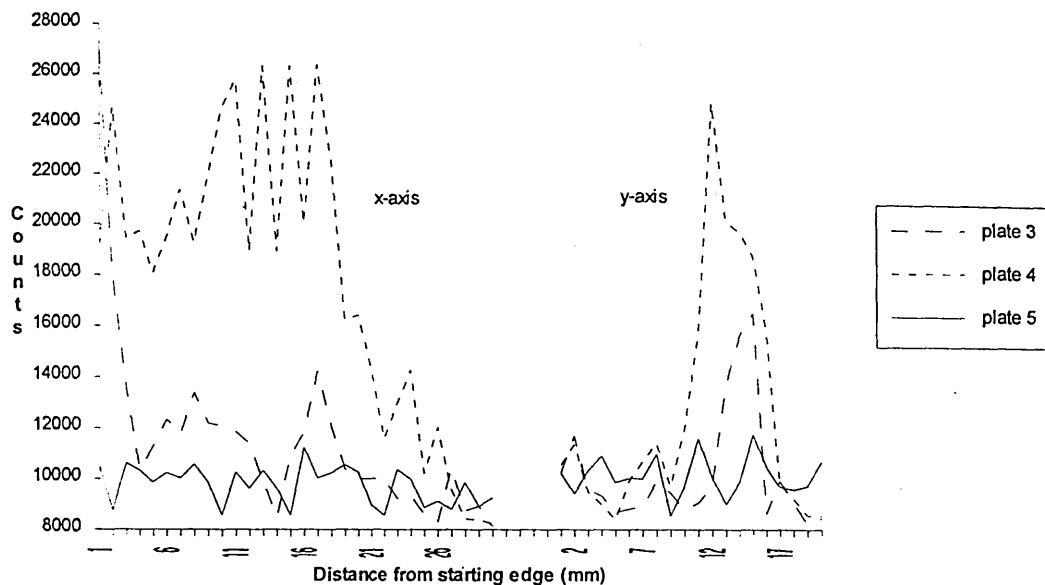

Fig. 13. Results from the ablation of sample 3, 4 and 5.

The results for sample 3 along the *x*-axis indicate two areas of cobalt, which agree closely with the two areas of protein observed on the Coomassie Brilliant Blue stained electrophoretogram (see Fig 11). When the results along the *y*-axis are reviewed, it is seen that the cobalt is detected in a narrow band across the gel, again this agrees with the Coomassie stained electrophoretogram. The laser ablation ICP-mass spectrometry system is therefore, capable of measuring the cobalt concentration in one-dimensional electrophoretograms. However, individual bands of proteins cannot be distinguished, due to either the low concentration of cobalt present or the poor resolution of the system.

For sample 4, large cobalt signals were observed along most of the *x*-axis. The 'fingers' that appear along the *x*-axis could be due to the cobalt associated in individual separated proteins. The two areas of cobalt, observed in the ablation of sample 3, are not observed in sample 4. However, these are not the same sample, as sample 4 has a higher cobalt concentration, the overall charge on the proteins could be vastly different. This would effect the separation of the proteins in sample 4, making it different to sample 3.

Unfortunately no Coomassie stained electrophoretogram was available for this sample. The results for the *y*-axis ablations, again show that the cobalt is situated in a narrow band in the centre of the electrophoretogram.

The results for sample 5 indicate that the cobalt has been 'lost' to the cathode. It is not observed as a band in the centre of the electrophoretogram, as was the cobalt present in samples 3 and 4. Therefore, any 'free' cobalt will not contribute to the signal obtained from the ablations. Only cobalt bound to protein is determined by laser ablation ICP-mass spectrometry.

3.3.3. Mapping.

The results for the one dimension electrophoretograms indicated that the proteins would need to be spiked with cobalt. This would allow the detection of cobalt by laser ablation ICP-mass spectrometry. Human serum was therefore spiked to give a final cobalt concentration of 12 mmol/l serum. The electrophoretogram was cut into 3 pieces (3 cm x 4 cm). Each piece was placed individually in the ablation chamber. The ablation pattern used to map the electrophoretogram is shown in Fig. 14. Each ablation point was 1 mm from the next ablation point in the *x*-axis, and ~0.7 cm from the next ablation point in the *y*-axis. Thirty four ablations were performed in each line, with four lines on each glass plate. The total number of ablations per glass plate was therefore 136. The total analysis time for each plate was approximately 2.5 hours, making the total analysis time for the crossed immunoelectrophoretogram ~8 hours.

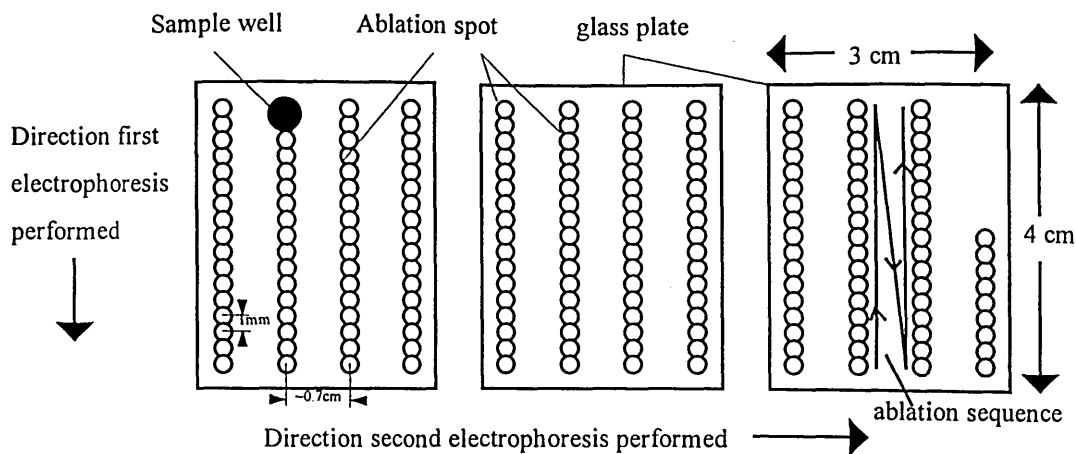

Fig. 14. Representation of the ablation pattern on the 3 glass plates containing the crossed immunoelectrophoretogram.

The areas of the peaks created by each ablation, were entered into a computer spreadsheet. A "map" Figure 15 was created which showed the areas where the cobalt concentration was significantly greater than the background signal. These areas of cobalt appear as shaded regions. The map created by the laser ablation ICP-mass spectrometry of the crossed immunoelectrophoretogram was compared to a similar electrophoretogram which had undergone autoradiography, see Fig. 16. Similarities between the two electrophoretograms can clearly be seen. The most obvious features, similar to both electrophoretograms are the sides of the albumin peak. The tops of the precipitin peaks, which contain the most of the cobalt, can also be seen for haptoglobin, alpha-1-lipoprotein, alpha-1-antitrysin, alpha-2-macroglobin and beta-1-lipoprotein. The laser ablation ICP-mass spectrometry map, overlaid with these peaks is shown in Fig. 17. Also, significantly, no cobalt is detected in the areas where the autoradiography indicates there should be no cobalt.

Although the precipitin peaks are not very well defined, this is a direct consequence of only ablating a small portion of the electrophoretograms. A fuller picture would have been created if the entire electrophoretogram had been ablated.

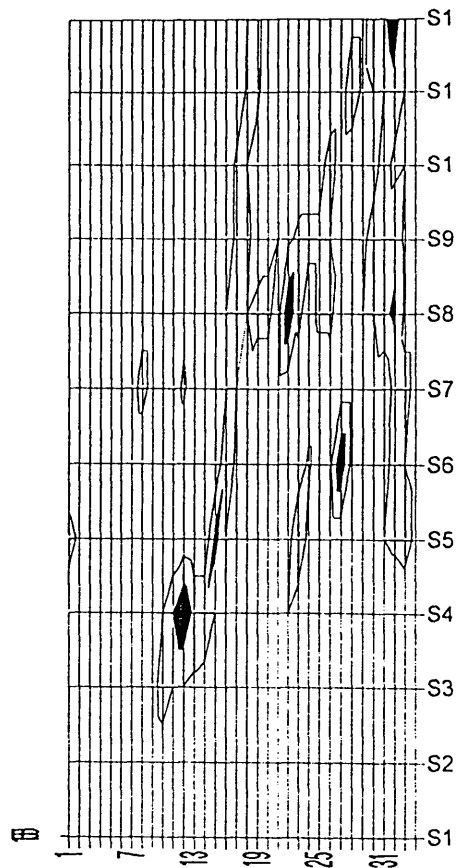

Fig. 15. Map created by laser ablation ICP-mass spectrometry of a crossed immunoelectrophoretogram of mixed human serum spiked with cobalt.

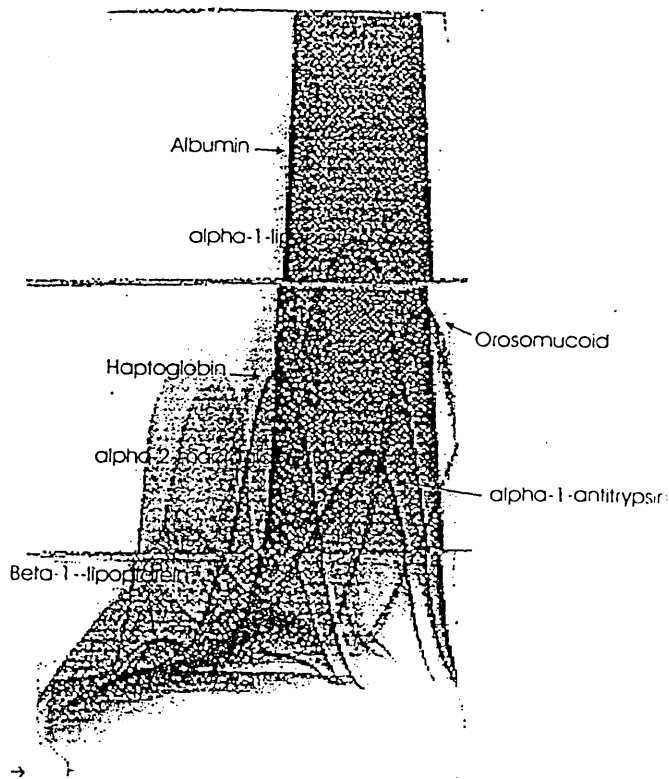

Fig. 16. Autoradiography of a crossed immunoelectrophoretogram of human serum.

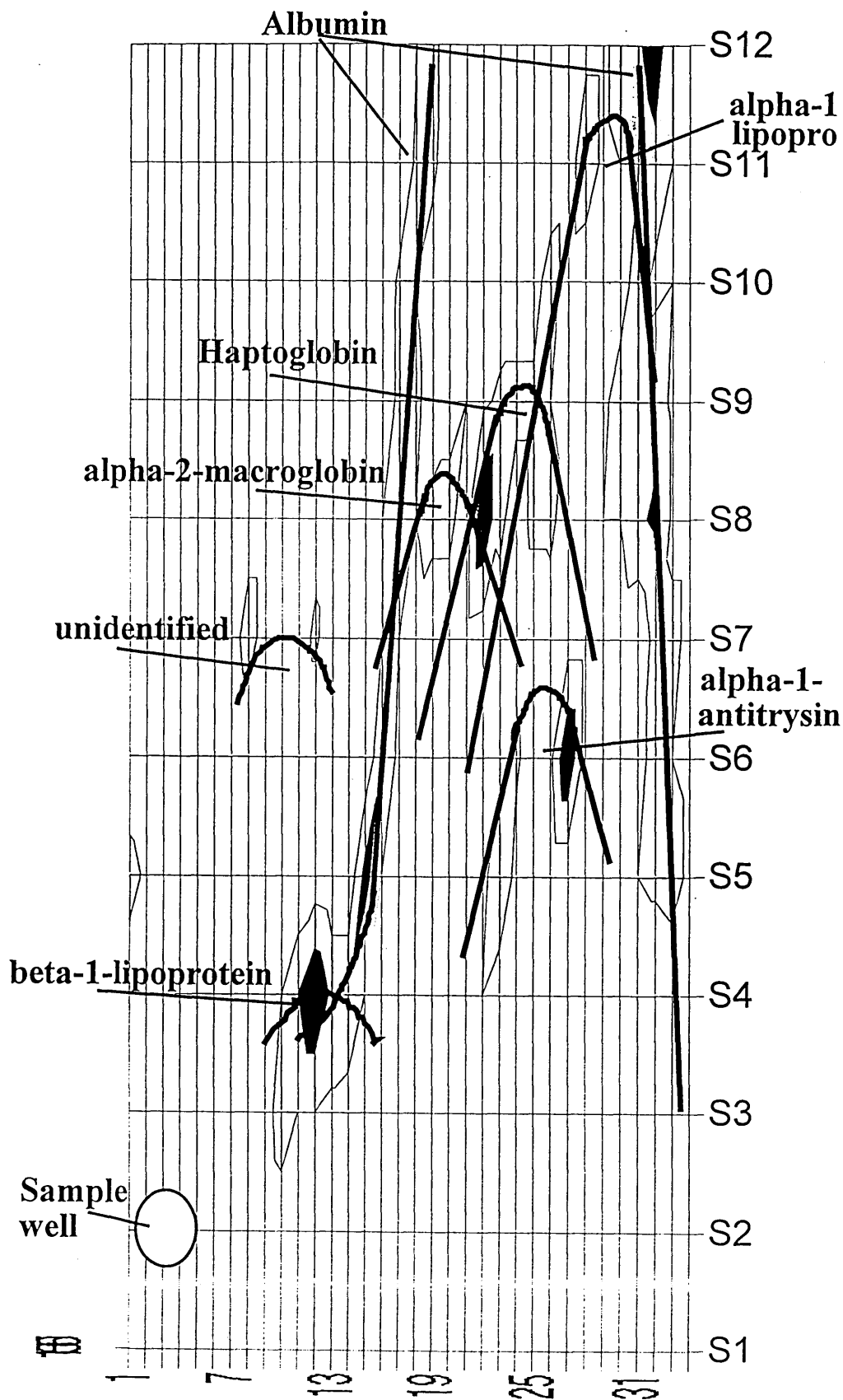

Fig. 17. Map of a crossed immunoelectrophoretogram created by laser ablation ICP-MS overlaid with the corresponding peaks.

3.3. Conclusions.

This study has shown the feasibility of analysing electrophoretograms by laser ablation ICP-mass spectrometry. The proteins can be separated, identified and quantified by the established technique of crossed immunoelectrophoresis. Using the ability of laser ablation to perform localised analysis, allows the quantification of any metals bound to the proteins. A frequent weakness of laser ablation is the inability to perform quantitative analysis because of lack of standards. However, gels can be prepared, containing a known amount of analyte, spread homogeneously throughout the gel. Firing the laser three times at the same ablation point, removes the variability in signal due to changes in the laser output power. This makes it possible to perform fully quantitative analysis, compared to the usual semi-quantitative analysis performed by laser ablation techniques. The analysis of gels prepared with a known concentration of analyte, has shown that a linear response is obtained over a wide dynamic range.

The sensitivity of the system is still poor and needs to be improved by at least two of orders of magnitude. Recent developments in ICP-mass spectrometers have made them more sensitive than the PlasmaQuad II+ used in these studies. These new systems would make it possible to analyse crossed immunoelectrophoretograms of proteins without the need to spike with analyte. An improvement in sensitivity would also allow the area ablated by each laser shot to be reduced. This would improve the resolution of the system.

The use of a larger ablation chamber, would remove the need to cut the electrophoretograms into 3 pieces. This would speed up analysis times as everything apart from changing the sample can be controlled by computer. A full mapping could be created in one day, this is dramatic reduction in analysis time when compared to the two weeks to perform autoradiography.

As the ICP-mass spectrometer is a multi-element instrument, the system would allow multi-element analysis to be performed on a single electrophoretogram. This would be

of interest in observing what effect an excess of one trace metal has on other trace metals.

3.4. References.

- [1] J. Versieck and R. Cornelis, *Trace Elements in Human Plasma or Serum*, CRC Press, Boca Raton, FL 1989.
- [2] T. C. Bøg-Hansen in *Gel Electrophoresis of Proteins - A Practical Approach*, D. H. Hames and D. Rickwood (eds.), IRL-Press, Oxford, 1990, pp. 273-300.
- [3] B. J. Scott and A. R. Bradwell, *Clin. Chem.*, 1983, **117**, 629.
- [4] A. Tiselius, *Transactions of the Faraday Society*, 1937, **33**, 524.
- [5] J. Uriel in *Immuno-electrophoretic analysis*, P. Grabar and P. Burton (eds.), Elsevier, Amsterdam, 1964, pp. 30-57.
- [6] T. H. Maiman, *Nature*, 1960, **187**, 493.
- [7] L. Moenke-Blankenburg, *Laser Micro-Analysis*, Wiley, New York, 1989.
- [8] *Laser-Induced Plasmas and Applications*, L. J. Radziemski and D. A. Cremers (eds.), Marcel Dekker, New York, 1989.
- [9] V. G. Mossotti, K. Laqua and W. D. Hagenah, *Spectrochim. Acta, Part B*, 1967, **23**, 197.
- [10] T. Ishizuka and Y. Uwamino, *Spectrochim. Acta, Part B*, 1983, **38**, 519.
- [11] P. K. Booth and C. W. McLeod, *Mikrochim. Acta*, 1989, **III**, 283.
- [12] M. Thompson, J. E. Goulter and F. Sieper, *Analyst*, 1981, **106**, 32.
- [13] H. Pang, D. R. Wiederin, R. S. Houk and E. S. Yeung, *Anal. Chem.*, 1991, **63**, 390.
- [14] R. C. Burnier, T. J. Carlin, W. D. Reents Jr., R. B. Cody, R. K. Lengel and B. S. Freiser, *J. Am. Chem. Soc.*, 1979, **101**, 7127.
- [15] R. Stoll and F. W. Roellgen, *Org. Mass Spectrom.*, 1979, **14**, 642.
- [16] T. Nosbeth in *Handbook on the Toxicology of Metals*, Elsevier, Amsterdam, 1986, pp. 462-481.
- [17] H. I. Maibach and T. Menné, *Nickel and the Skin: Immunology and Toxicology*, CRC Press, Boca Raton, FL 1989.
- [18] International Agency for Research on Cancer, World Health Organisation, *IARC Monographs on the evaluation of carcinogenic risks to humans. Chlorinated drinking-water; chlorinated by-products; some other halogenated compounds; cobalt and cobalt compounds.*, 1991, **52**, 363.

- [19] S. Fregert, B. Grewberger and A. Heijer, *Acta Derm. Venerol. (Stockh.)*, 1972, **52**, 221.
- [20] Y. Morin and P. Daniel, *Canad. Med. Assoc. J.* 1967, **97**, 976.
- [21] E. J. Underwood, *Nutri. Rev.*, 1975, **33**, 65.
- [22] E. J. Underwood and J. F. Filmer, *Austral. Vet. J.*, 1935, **11**, 84.
- [23] E. L. Rickes, N. G. Brink, F. R. Koniusky, T. R. Wood and K. Folkers, *Science*, 1948, **108**, 134.
- [24] E. L. Smith, *Nature (London)*, 1948, **162**, 144.

4. SPECIATION VIA ELECTROTHERMAL VAPORISATION - TIME OF FLIGHT - MASS SPECTROMETRY.	118
4.1. Introduction	119
4.2. Experimental.	123
4.2.1. Sample Introduction.	124
4.2.2. Ion Source.	124
4.3. Results and Discussion	126
4.3.1. Ionisation and Fragmentation	126
4.3.2. Reproducibility of the Coils.	129
4.3.3. Calibration Curves for Ag, Cu, Mg and Pb	129
4.3.4. Vaporisation profiles.	132
4.3. Speciation.	139
4.3.1. Chromium.	139
4.3.2. Chromium - Copper mixtures	147
4.4. Conclusion and Future Work.	150
4.5. References.	152

**4. Speciation Via Electrothermal Vaporisation - Time of Flight -
Mass Spectrometry.**

4.1. Introduction

The ability to measure the molecular species directly in a solid sample, without performing any separation chemistry, would be a great advantage to speciation analysis. The use of electrothermal vaporisation to generate the molecular species in combination with a time-of-flight mass spectrometer, to measure all of the species simultaneously makes this feasible.

This research will first characterise a prototype instrument, which in theory should be able on the one hand to provide an extremely sensitive multielement analysis technique, and by slightly changing instrument parameters, to be utilised as an extremely powerful tool for speciation.

Initial studies will look into the effect of instrumental parameters on ionisation and fragmentation. Later studies indicate the feasibility of this technique to identify molecular species present in a simple standard solution.

Electrothermal vaporisation (ETV) provides a means to introduce solid samples to analytical instrumentation. However, to achieve the full benefits of ETV a highly efficient multielement detection system is required. The inductively coupled plasma - mass spectrometer (ICP-MS) has shown itself to be a powerful tool for analytical mass spectrometry of the elements despite low efficiencies of sample introduction and sequential detection using quadrupole mass filters. However, since in ICP-MS the sample is ionised by an high temperature plasma, information on the molecular constitution is lost. Therefore a means to directly analyse solid species samples is required. A new proposal for this comes from Spectro Analytical and is based on a novel combination of an electrothermal vaporiser, an electron impact ion source with storage capabilities and a time-of-flight (ToF) mass spectrometer. Because of their

inherent mode of operation, ToF mass spectrometers represent truly simultaneous measurement for ions of all masses without any loss in sensitivity.

This concept for a new generation of elemental mass spectrometer is directed toward achieving high efficiencies of sample introduction and detection on the one hand, and controlled dissociation of the molecular species of the sample on the other hand. As a result, the new instrument will have high detection sensitivity as well as speciation capability.

Time-of-flight mass spectrometry finds many applications in the field of analytical chemistry today, these include:

Laser Microprobe Mass Spectrometry

Resonance Ionisation

Spark-Source Mass Spectrometry

Particle Impact Analyser

Secondary Ion Mass Spectrometry

Plasma Desorption Mass Spectrometry

Matrix Assisted Laser Desorption Ionisation

Soon after their development in the early 1960's, lasers were applied in mass spectrometry. Currently, the LAMMA-500 (laser microprobe mass alyser) has been available for applied research for some years^[1].

Application of the LAMMA-500 is limited to microscopic samples thin enough to be perforated by the laser beam: histological sections, films and powdered materials on a thin supporting foil. To extend the utility of the instrument for chemical microanalysis of bulk specimens, the LAMMA-1000 has recently been developed; its sample and source are modified to have the laser irradiation and ion extraction on the same side of the sample (reflection geometry).

Recently, a laser-induced ion mass analyser called the LIMA-2A^[2,3] has been manufactured; it is capable of performing microanalysis in either the transmission mode for thin samples or using reflection geometry for thick specimens. A high vacuum can be maintained in the main analysis chamber to provide compatible conditions for physio-chemical studies of surfaces.

The combination of resonance ionisation and time-of-flight mass analysis has recently been proposed as a powerful analytical tool for monitoring trace pollutants^[4,5]. This technique consists of selectively exciting and ionising atoms of the chosen elemental impurity from an unionised gaseous sample by means of tuned laser radiation. After a certain time delay the resulting ions are analysed by a ToF-MS. Only the neutral atoms are thus used for the resonance ionisation process. In a similar way the direct action of a vaporising laser pulse on solid matter may yield the involved neutrals as well.

At the present time there is a need for characterising a variety of new materials for the microelectronics industry, based on high-purity gallium, arsenic, selenium, tellurium, indium, and so on, and this need can be expected to persist for some time to come. Although other analytical techniques may be suitable for determining selected impurities at the ppb level, SSMS is unsurpassed when it comes to obtaining a general view of the entire periodic table.

The development of simple, small, relatively cheap, and at the same time highly automated instruments to carry out survey quantitative elemental analysis of natural objects and technical materials is important to the success of SSMS. It requires the construction of spark ion sources with reduced energy spread. The first experiments to combine the spark ion source and a ToF analyser with ion reflector were promising. For some applications, this development could be of interest because it makes possible the detection of the entire mass spectrum from one single spark.

In 1986 the comet Halley entered the inner solar system, the European Space Agency's GIOTTO mission spacecraft carried several instruments for analysing the composition of the dust forming the comet's tail^[6]. One of these instruments was a particle impact analyser (PIA) whose operation was based on the instantaneous ejection of atomic and molecular ions from a surface of a solid material during an impact of a fast dust particle. These ions can be detected and analysed by a specially designed ToF-MS. The start signal for each mass spectrum can be achieved either by the light flash which accompanies the impact or by the charge pulse at the target. The flight path incorporates a reflector to enhance resolution.

Secondary Ion Mass Spectrometry (SIMS)^[7,8] is the mass spectrometry of ionised particles which are emitted when a surface, usually a solid, though sometimes a liquid, is bombarded by energetic primary particles. The emitted (“secondary”) particles will be electrons; neutral species, atoms, and molecules; atomic and cluster ions. It is the secondary ions which are detected and analysed by a mass spectrometer. It is this process which provides a mass spectrum of a surface and enables a detailed chemical analysis of a surface or a solid to be performed.

In ToF instruments the secondary ions must be produced at a definite point in time, which is best achieved by pulsing the primary ion into a short burst of <10ns - the time scale of secondary ion emission after impact is negligible (<10⁻¹²s).

An interesting feature of linear ToF systems is that once the ions have completed the initial extraction-acceleration stage (<1 ms), the ions are in a field free drift region. If the ion is metastable and dissociates in the flight tube (usually giving one charged and one neutral daughter to conserve charge), the principle of conservation of momentum means that the centre of mass of the pair has the same velocity as the parent ion. In the absence of any external fields, the daughters will therefore strike the detector with the same time as would the original ion had no dissociation occurred, and thus appear as a peak at the original mass. The observed spectrum is then that of secondary ion distribution ~1 ms after emission. In comparison, ions must survive intact until after mass analysis (>100 ms) is completed to be detected in a magnetic sector or quadrupole system, and so metastable ions are effectively lost from the spectrum.

A major stimulus for the resurgence of ToF-MS was the development of the ²⁵²Cf plasma desorption mass spectrometry (PDMS)^[9,10]. The technique exploits high energy fission fragments from a ²⁵²Cf source to bombard solid samples. Secondary ions ejected from the sample are analysed using ToF-MS

Electrothermal vaporisation is a system by which a tungsten coil is heated electrically to a very high temperature causing the sample to vaporise into a gaseous form.

Electrothermal vaporisation offers the following well known advantages:

- low sample volume requirement
- high transport efficiency (20-80%), thus increasing the sensitivity

- the ability to handle samples containing organic, high acid and high solid matrices
- thermal separation of the analyte from the sample matrix using a temperature gradient, thus potentially eliminating the interferences associated with background polyatomic species and matrix-induced effects
- the potential to minimise or avoid sample pre-treatment.

The combination of ETV with ToF-MS will allow molecular species in the solid state to be vaporised by the ETV process and be analysed by the ToF-MS.

The work during this research will show the potential of new and novel approaches for utilising analytical techniques to perform speciation studies.

4.2. Experimental.

The instrument consisted of two chambers separated by a sliding gate valve, see Fig. 1. One chamber contains the time of flight mass spectrometer, while the second chamber is for the loading and drying of the sample.

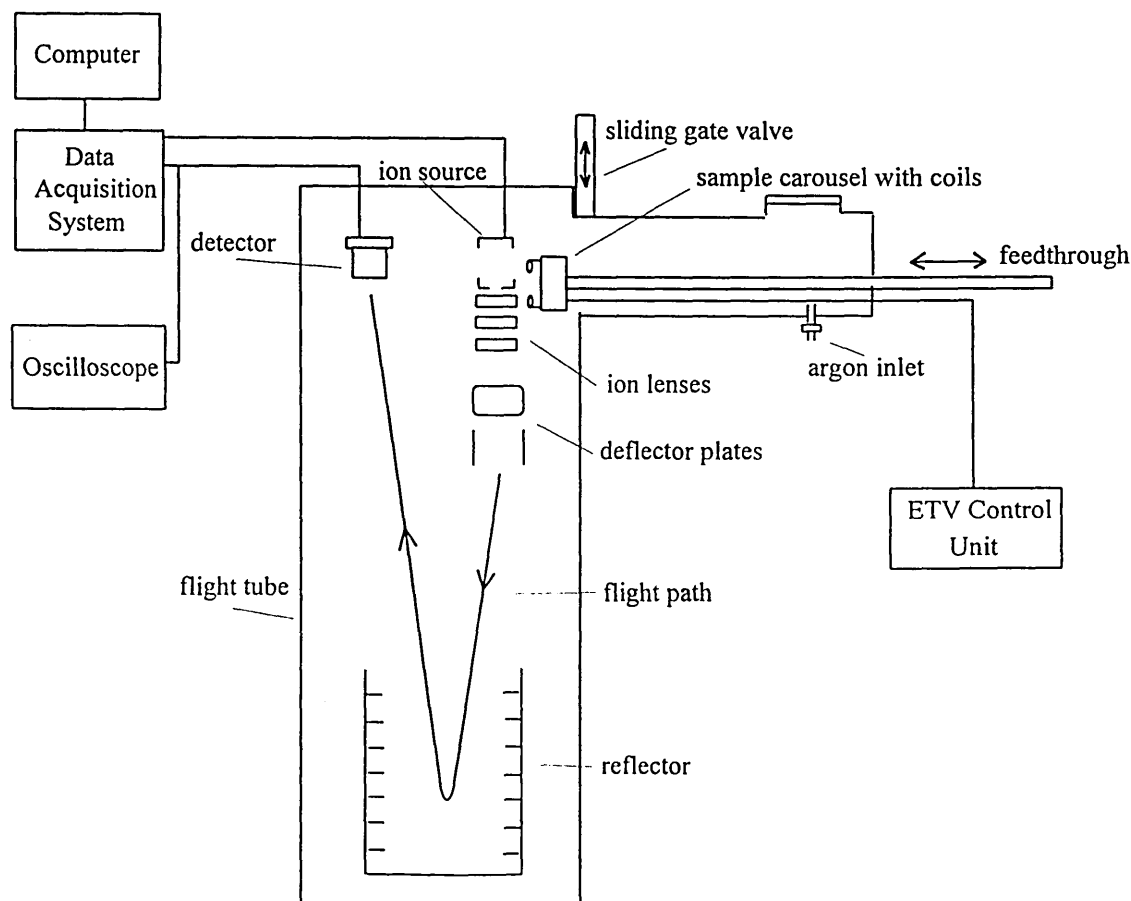

Fig. 1 Schematic of the SpectroAnalytical ETV-ToF-MS.

4.2.1. Sample Introduction.

Sample introduction was accomplished in the following manner. A tungsten coil is positioned at the top of a manual linear feedthrough arm. When the feedthrough arm is in the drawn back position, the tungsten coil is located in the sample chamber and the sliding gate valve is closed. The sample chamber is filled with argon gas and opened. A 10 μl volume of sample is manually loaded onto the tungsten coil with the use of a microlitre pipette, under a carrier stream of argon gas. An electric current is then passed through the tungsten coil, heating the coil, and evaporating the water from the sample. The argon gas transports the evaporated water out of the sampling chamber and prevents atmospheric moisture from entering the sample chamber. When the water has been removed from the tungsten coil, the electric current is switched off and the sample chamber is sealed. The argon flow is then stopped and the sample chamber evacuated by a turbomolecular pump. When the required vacuum has been obtained in the sample chamber, the sliding gate valve is opened. The feedthrough arm is then pushed in, to position the tungsten coil in front of the ion source. An electric current is then passed through the tungsten coil, causing the vaporisation of the sample into the ion source. However, it is calculated that a transport efficiency of only 3% is achieved using this system.

4.2.2. Ion Source.

The sample once vaporised, enters the ion source. The atoms and molecules from the sample are ionised and/or fragmented by high energy electrons being emitted from the cathode to the anode.

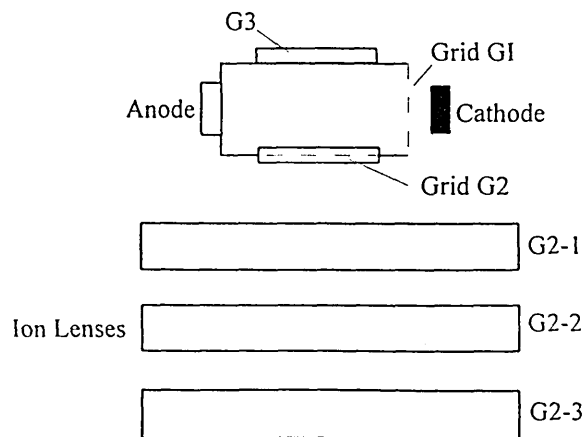

Fig. 2 Schematic of the ion source.

The energy of these electrons is determined by the potential difference between the cathode and the grid G1. The continuously produced ions are stored in the source, for a variable time period (0.001-0.1 s), by the potentials applied to G1 and G2. The ions are extracted from the ion source via an electrical pulse. The pulse can be either a large positive pulse on G3, or a large negative pulse on the grid G2.

The ions are accelerated down the flight tube by gradient potentials applied to the ion lenses G2-1, G2-2 and G2-3. The ion lenses, along with the deflectors and the reflector improve the resolution of the time of flight mass spectrometer.

The normally poor resolution of time of flight mass spectrometers is due to ions taking different paths to the detector, and to the fact that not all the ions receive the same amount of kinetic energy from the large pulse applied to extract the ions. This is because the ion source has a finite volume. The deflectors and ion lenses, force the ions down the same flight path. While the reflector compensates for an energy spread of up to 10%, as ions with higher kinetic energy go deeper into the reflector than those with low kinetic energy. So ions of the same m/z ratio, but different kinetic energies will reach the detector at the same time. The final pulse width at the detector is comparable to the starting pulse width. For the time resolved detection, two micro-channel plates (MCP) in a Chevron configuration are used.

The signal from the MCP is sent to either an oscilloscope or a data acquisition system (DAS). The data acquisition system, however, works in a sequential mode, measuring only one channel of each mass for every pulse. As each peak has 10 channels, to scan the mass range 101-200 amu, at a pulse rate of 1000 Hz requires one second. This severely limits the sensitivity of the instruments, and negates the fact that the time of flight mass spectrometer is a simultaneous instrument.

The ability to minimise fragmentation in the ion source is assessed, along with instrument characteristics such as mass bias, detection limits, linearity, etc.

4.3. Results and Discussion

4.3.1. Ionisation and Fragmentation

The sample once it has been vaporised from the tungsten coil, enters the ion source. The ion source, not only produces the ions, but also stores them prior to pulsing the ions down the flight tube. The vaporised sample is ionised by a stream of high energy electrons being emitted by a cathode situated in the ion source. The energy of these electrons are determined by the potential difference between the cathode potential and the potential on the grid GI. The effect of electron energy on the ionisation of the sample can be seen in Fig. 3.

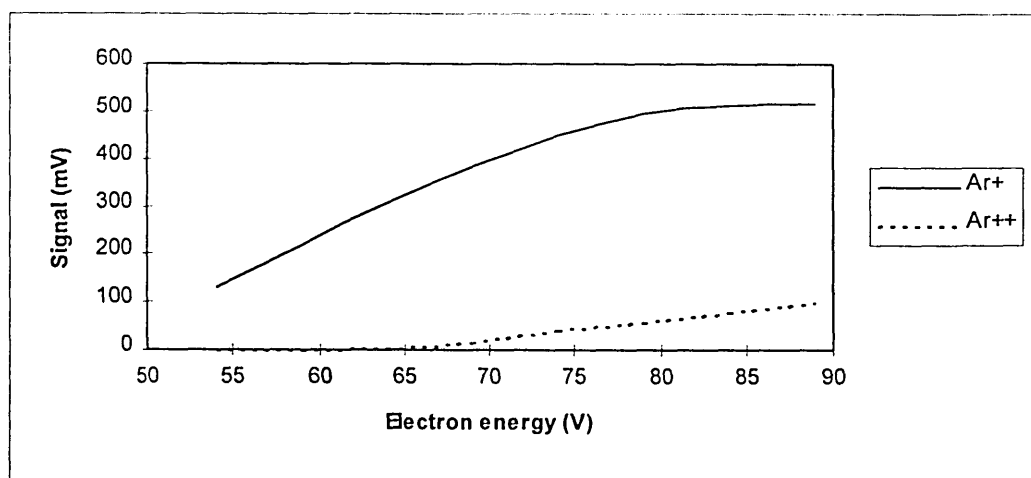

Fig. 3 Effect of electron energy on the ionisation and double ionisation of argon.

The signal increases linearly with an increase in electron energy, until an electron energy of 80V is reached. At this point it can be assumed that all of the argon is present as argon ions. The high electron energy levels also cause a considerable amount of double ionisation. To ensure that spectra are simple, it will be necessary to reduce the amount of double ionisation, although this is at the expense of sensitivity.

As well as controlling the energy of the electrons, it is also possible to control the number of electrons by controlling the current applied to the cathode. As is shown in Fig. 4, again there is a linear response between the number of electrons produced and the signal observed. However, the amount of double ionisation does not increase in the

same way. This indicates that it is the energy of the electrons and not the number of electrons present that greatly controls the amount of double ionisation.

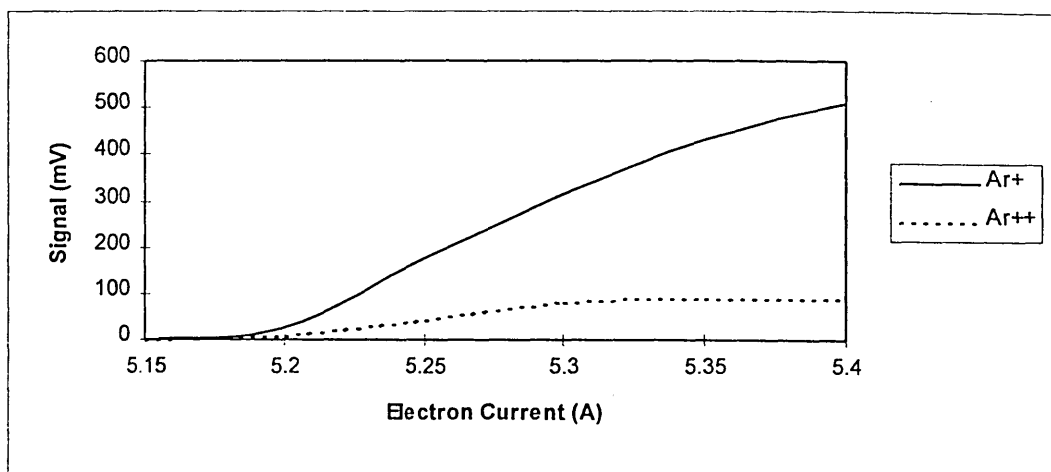

Fig. 4 Effect of electron current on ionisation. (Electron energy at maximum potential)

With speciation analysis we are interested in molecular species rather than elemental concentrations. It is therefore, necessary to prevent fragmentation from occurring in the ion source. In Fig. 5 it can be seen that an high electron energy causes greater fragmentation. It will therefore be necessary to work at low electron energy levels. Although this will reduce the amount of fragmentation and double ionisation, the signal intensity will be greatly reduced.

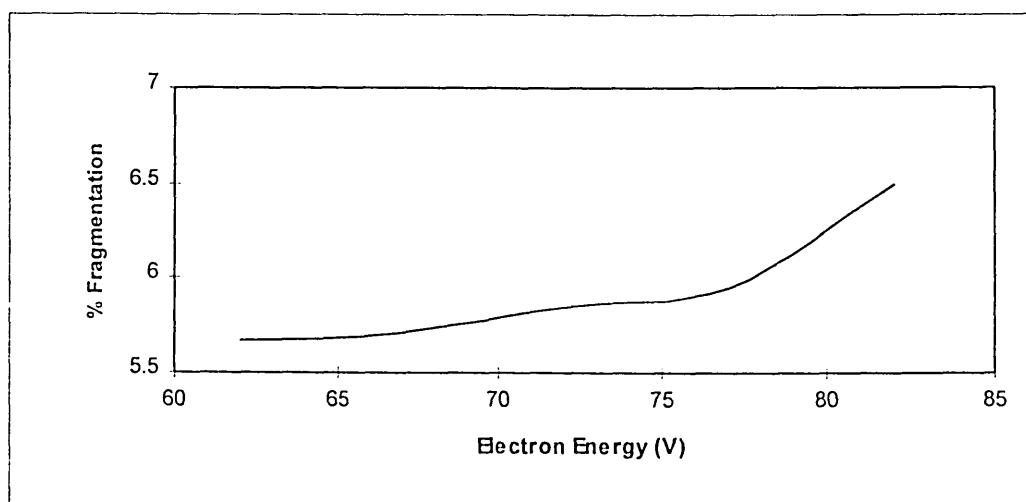

Fig. 5 Effect of electron energy on the fragmentation of $N_2^+ \rightarrow N^+$.

Once the ions have been created in the ion source, they are contained in the ion source by the potentials G2 and G3. These potentials bunch ions of equal mass into 10 ns groups in the ion source. The effect of these potentials on the signal can be seen in Fig. 6.

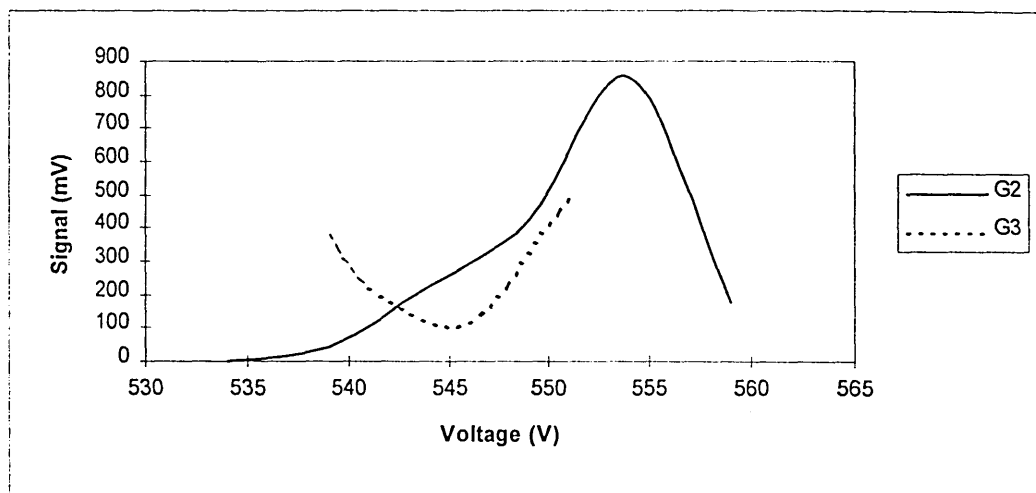

Fig. 6. Effect of storage potentials, G2 and G3, on the signal for Ar^+ .

The potential G2, situated at the top of the ion source has a dramatic effect on the signal. The longer the ions are stored before pulsing the ions down the flight tube the larger the signals. There is an inverse linear relationship between pulse frequency and signal intensity, i.e. the higher the pulse frequency, the lower the observed signal. However, the data acquisition system works in a sequential mode, recording one channel for each pulse. It is necessary, therefore, to have an high pulse frequency if large mass scans are to be performed.

The next stage in the basic operation experiments were performed using the electrothermal vaporisation unit for sample introduction.

4.3.2. Reproducibility of the Coils.

The coils were each loaded with 10 μl of 100 $\mu\text{g/l}$ magnesium solution. The samples were dried and the coils introduced to the ion source and vaporised sequentially. This was repeated, and the areas of the transient signals produced at mass 24 were calculated. The results are shown in Fig. 7.

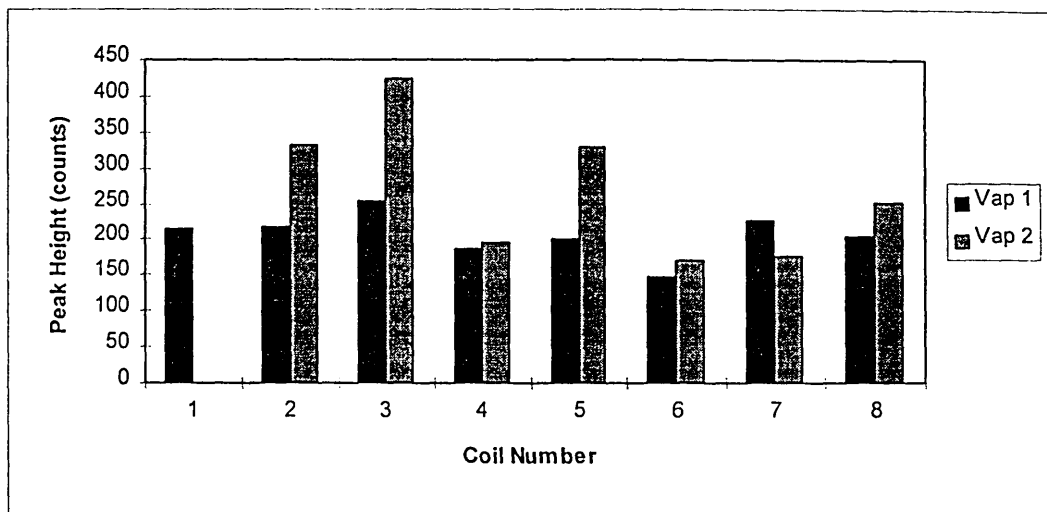

Fig. 7 Results from the vaporisation of magnesium from the tungsten coils.

The means and the standard deviations for vaporisations 1 and 2 were 207 ± 31 and 269 ± 96 , respectively. Although these results appear to be very poor, the ETV system was of a very simple design. This leads to possible deviations in the heating ramp speed and the final temperature. Slight differences in the heating profiles could lead to differences in the evaporation profiles, and so to the peak height. An improved ETV system would improve these results.

4.3.3. Calibration Curves for Ag, Cu, Mg and Pb

To assess the linearity and relative response of the ToF-MS, four elements were analysed from across the mass range. These were;

Element	Mass
Magnesium	24
Copper	65
Silver	107
Lead	208

Table I Elements and isotopes chosen to check response of the ToF-MS.

The tungsten coils were loaded with mixed standard solutions (10 μ l). The solutions were dried and then introduced to the ion source and vaporised sequentially. The experiment was repeated and the corresponding calibration graphs are shown below:

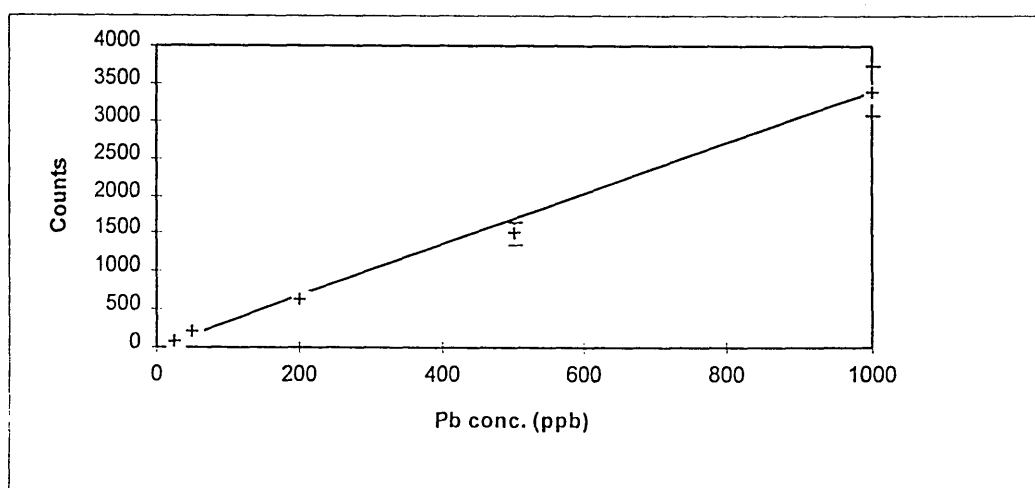

Fig. 8 Calibration graph for lead (10 μ l sample volume)

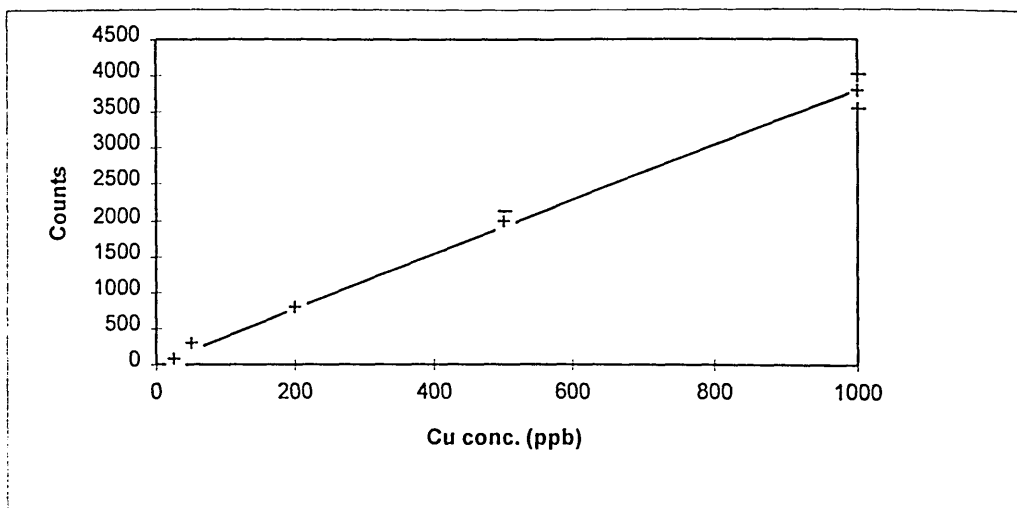

Fig. 9 Calibration graph for copper (10 μ l sample volume)

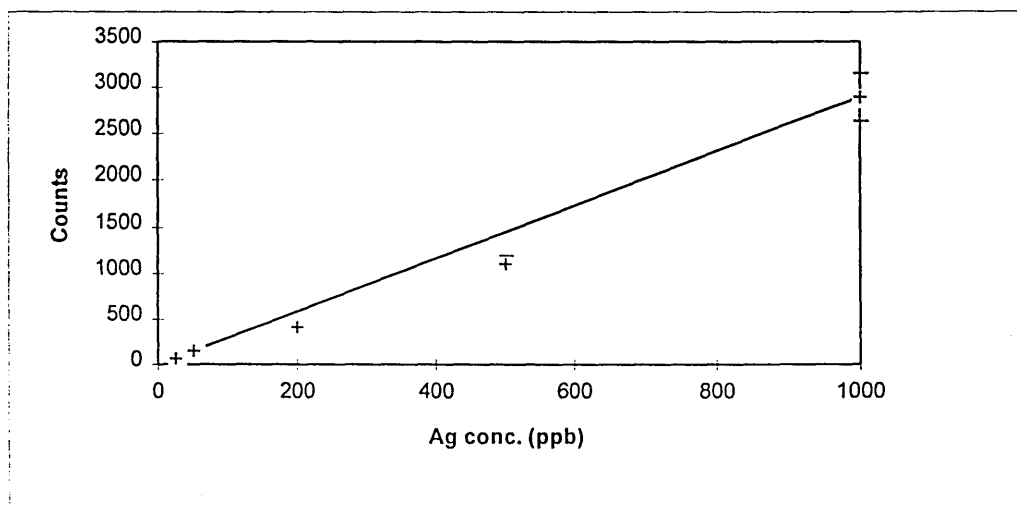

Fig. 10 Calibration graph for silver (10 μ l sample volume)

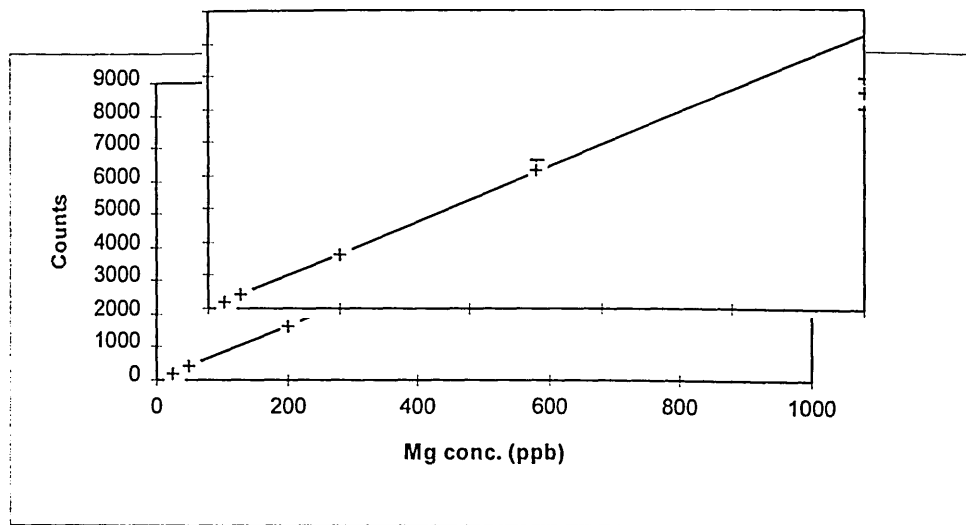

Fig. 11 Calibration graph for magnesium (10 μ l sample volume)

The intensity of the signals across the mass range are very similar, with the possible exception of magnesium. This is due to the relative ease in which magnesium is ionised compared to the other elements. However, the similar response observed for the other elements, which have similar ionisation potentials, show that the ToF-MS shows very little mass bias effects. This response would allow rapid semi-quantitative data to be obtained across the entire elemental mass range.

4.3.4. Vaporisation profiles.

It is essential to obtain a set of vaporisation parameters which will vaporise all of the elements at the same time. The vaporisation profiles for three elements (magnesium, copper and silver) are shown in Fig. 12. The peak widths and hence the vaporisation, are different for all three elements, the greatest difference being observed for magnesium.

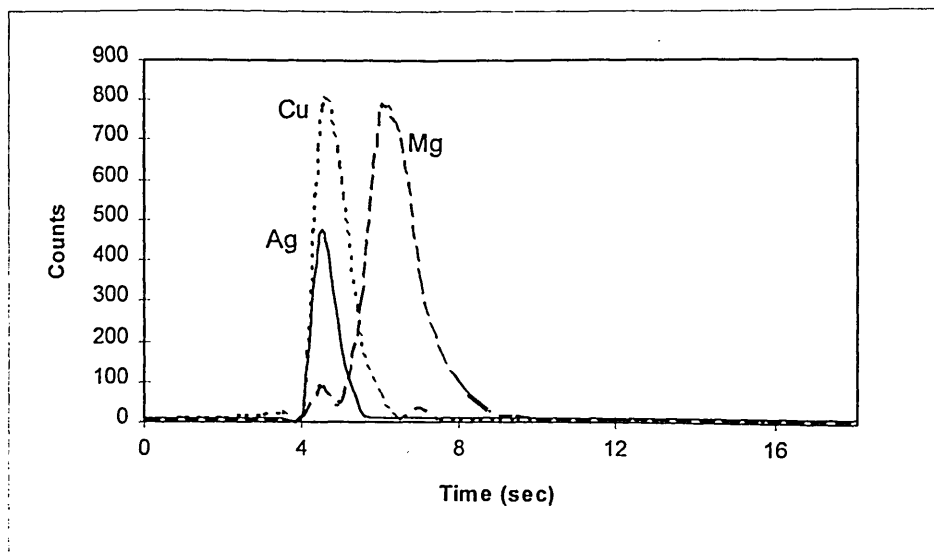

Fig. 12 Vaporisation profiles for various elements.

A set of vaporisation parameters is required which will not only vaporise a single element or molecular species efficiently, but will vaporise all analytes at the same time. From Fig. 12 it can be seen that magnesium vaporises considerably later than the other two elements. This longer time period requires a greater amount of processing power for the computer.

To assess the ability of the system to determine which species of a compound is present, initial studies concentrated on simple standard solutions of magnesium, copper and nickel. The ETV parameters were:

Stage	Voltage (volts)	Time (secs)
Ashing	0.2	5
Vaporisation	1.5	7
Cleaning	2.0	5

Table II Stage times and voltages during the ETV program

As the acquisition system collected data in a sequential mode, instead of observing the entire mass range, assumptions were made on which species would be present. The masses of the suspected species and various fragments were observed. For magnesium, if it were assumed that the species present would be $\text{Mg}(\text{NO}_3)_2$ then the amu of $\text{Mg}(\text{NO}_3)_2$ and various fragments would be observed. However although the peak representing Mg^+ rose significantly as expected, no signals were observed for the various fragments being observed. This suggested that the species present was not $\text{Mg}(\text{NO}_3)_2$. Therefore if it were assumed that the species present was MgSO_4 , then the amu of MgSO_4 and various fragments would be observed. This time, significant signals were observed, which indicated that MgSO_4 was used to produce the magnesium standard. However, no signal was observed for MgSO_4^+ , The results seemed to indicate that the magnesium and the sulphate were vaporised as separate components. This can be seen in Fig. 13.

A similar observation was made during the determination of the copper species. The copper species present was $\text{Cu}(\text{NO}_3)_2$, however, again no signal was observed for $\text{Cu}(\text{NO}_3)_2^+$. Time profiles for Cu^+ and NO_3^+ (see Fig. 14) show that the nitrate is evaporated during the ashing stage. A different temperature profile is therefore required to prevent the molecular species from dissociating during the vaporisation.

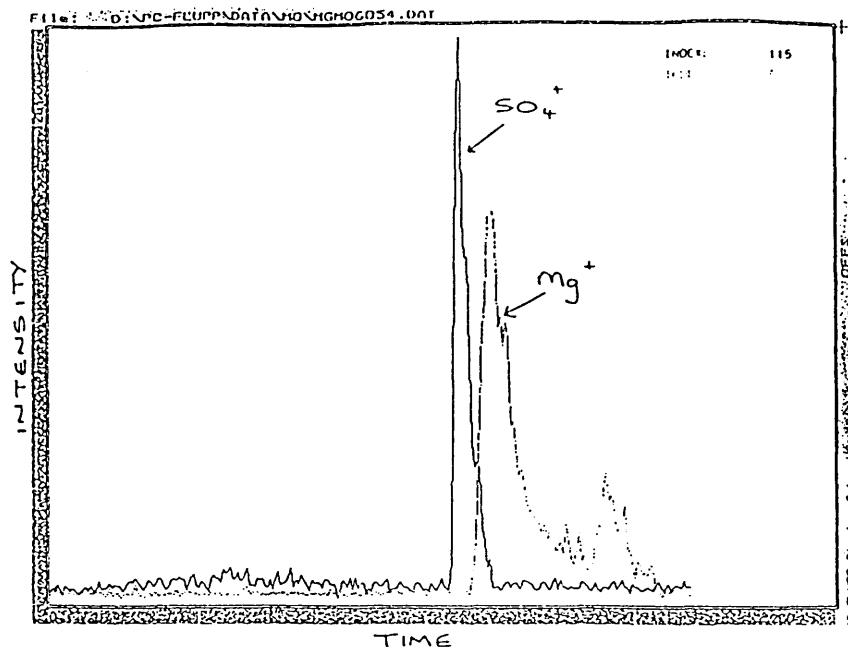

Fig. 13 Vaporisation profile of magnesium sulphate, showing the dissociation of the compound during vaporisation

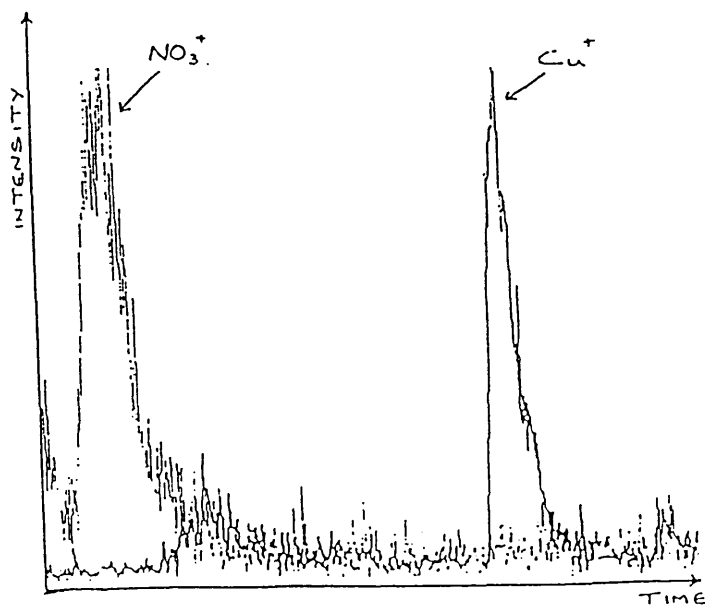

Fig. 14 Vaporisation profile of copper nitrate showing the dissociation of the compound during the ashing stage.

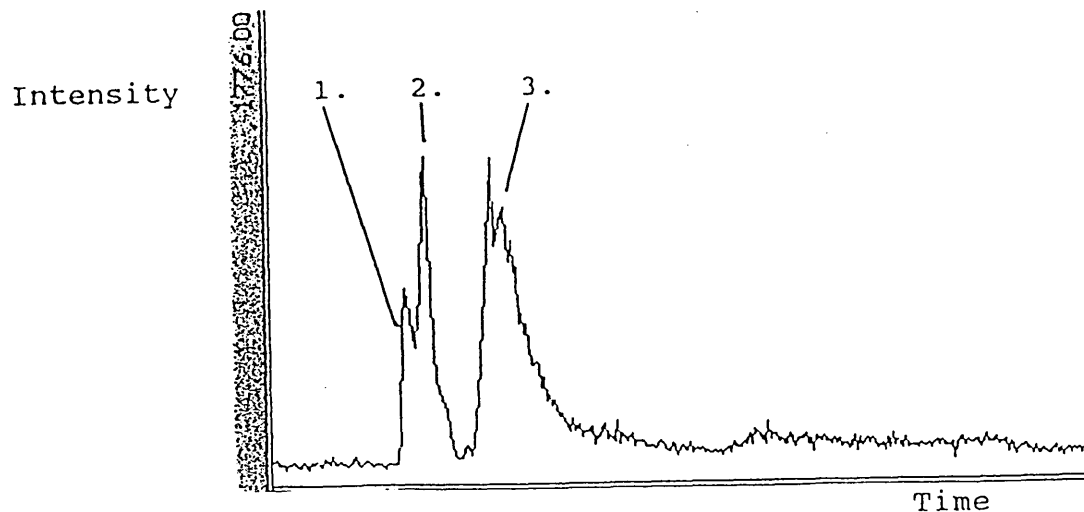

Fig. 15 Vaporisation of nickel chloride.

During the vaporisation of nickel, monitoring mass 58, three distinct peaks can be observed (see fig. 15). The first of these signals is due to a rise in the background spectra during the ashing stage. Shortly after the background rise, a second peak appears during the ashing stage followed by a third signal during the vaporisation stage. The nickel standard was prepared in HCl, therefore mass 35 was observed to see what happens to the chloride. A signal for Cl^+ is observed at the same time as the second signal at mass 58, no signal was observed for Cl^+ during the vaporisation stage. Reference books show that NiCl_2 sublimates at a lower temperature than Ni. It is therefore assumed that the second peak appearing at mass 58 is due to the fragmentation of Ni vaporised as NiCl_2 then fragmented to Ni^+ . This is established by observing masses 93 and 128, which correspond to NiCl and NiCl_2 , respectively. Signals at these two masses are observed during the ashing stage. The signal for NiCl_2 could be increased in respect to NiCl and Ni by lowering the electron energy and so preventing the fragmentation of NiCl_2 to NiCl, Ni and Cl. As no signal is observed for NiCl_2 or Cl during the

vaporisation stage, the chloride is being dissociated from the nickel during the ashing stage.

To prevent the dissociation which was observed for all three systems at different points and to different degrees, the temperature profile needs to be changed dramatically. For the determination of chromium species present, the following temperature profile was utilised;

Stage	Voltage (volts)	Time (secs)
Ashing	3.5	1
Vaporisation	1.8	7
Cleaning	1.8	3

Table III Vaporisation voltages and times to perform speciation analysis.

For the speciation of chromium, the ashing stage has been removed to reduce the possibility of sample dissociation from the coil. Instead, a high temperature, rapidly ramping stage has been inserted, to “shock” the compounds from the coil before they can dissociate. The electron energy has also been reduced from 61 eV to 30 eV to reduce the amount of fragmentation which occurs in the ion source/trap after the sample has been vaporised. The data collection parameters have also been changed, to cover a much larger mass range. However, due to the sequentially nature of the data collection system, much of the data will be lost. The different parameters used for elemental analysis and molecular analysis are shown in Table IV.

	Chromium Speciation	Elemental Analysis	
ETV parameters:			
Drying voltage (2 coils)	0.3	0.3	volts
Ashing voltage	3.5	0.2	volts
Vaporisation voltage	1.8	1.5	volts
Cleaning voltage	1.8	2.0	volts
Drying time (2 coils)	90	90	secs
Ashing time	1	5	secs
Vaporisation time	7	7	secs
Cleaning time	3	5	secs
Source potentials:			
G3	552	545	volts
G2	554	550	volts
GI	560	560	volts
Cathode	530	499	volts
Anode	560	560	volts
G2-1	351	350	volts
Others:			
Pulse frequency	10	2	kHz
Sample size	10	10	μl
No. of Spectra	30	750	
No. of Channels	1500	50	
No. of Integrations	1	1	
Time per spectra	0.15	0.025	secs

Table IV Comparison of instrument parameters for speciation and elemental analysis.

4.3. Speciation.

The ashing stage is replaced by a short high temperature vaporisation stage, to help prevent sample dissociation, and hence to allow molecular information to be obtained. The electron energy, i.e. the potential difference between the cathode and GI, is reduced to prevent fragmentation of the compounds in the ion source. Unfortunately this also reduces the amount of ionisation and therefore the sensitivity of the system is dramatically reduced. As it is not known which fragments to expect, a large number of channels had to be measured, this takes a longer time period and so the pulse frequency, (one channel is measured for every pulse from the ion source), had to be greatly increased. Both of these factors reduce the sensitivity of the system.

4.3.1. Chromium.

When scanning the mass range 30-280 amu for the vaporisation of the compounds $K_2Cr_2O_7$, $CrCl_3$, $Cr(NO_3)_3$ and CrO_3 , different spectra can be observed (see figs. 16,17,18,19. However, due to the large number of channels being monitored between the mass range 30-280 amu, these spectra were not always reproducible due to the scanning nature of the data acquisition system. The only compound which is not totally dissociated or fragmented was that of $CrCl_3$. Therefore spectra were obtained looking at only certain fragments of the compounds. The CrO_3 , $Cr(NO_3)_3$ and $K_2Cr_2O_7$ solutions were made up in water, the $CrCl_3$ solution was made up in dilute HCl, however only water was used to prepare the blanks for ease. Differences between the blanks and the various chromium spectra can be seen (see figs. 20, 21, 22, 23), however these spectra, particularly for $K_2Cr_2O_7$ and $Cr(NO_3)_3$, were not always reproducible. These spectra show how complicated a mass spectrum would be for a "real" sample. These results do seem to show that it is necessary to obtain an improved introduction system than the one currently used and a simultaneous data acquisition system is essential.

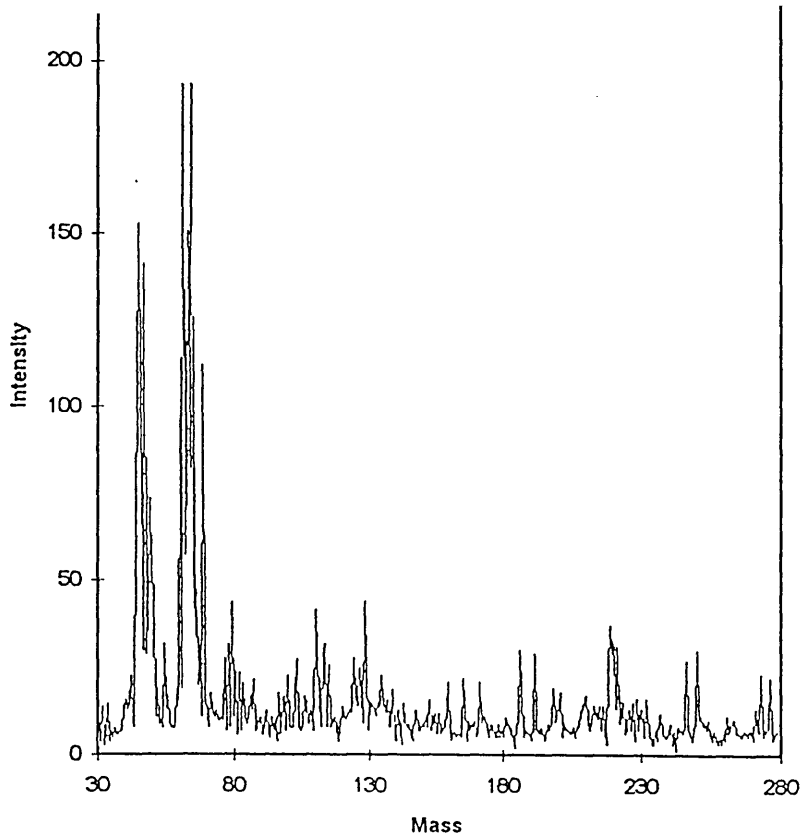

Fig. 16 Mass spectrum over the range 30-280 amu for $K_2Cr_2O_7$ (10 μ l, 10ppm), taken a few seconds after the vaporisation step.

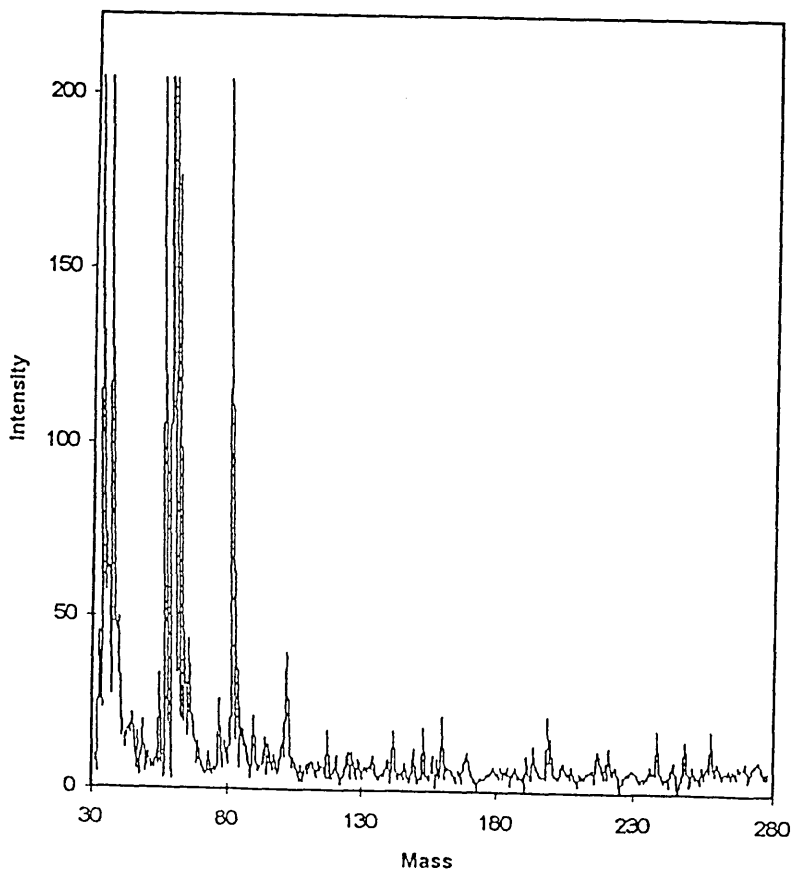

Fig. 17 Mass spectrum over the range 30-280 amu for $CrCl_3$ (10 μ l, 10ppm), taken a few seconds after the vaporisation step.

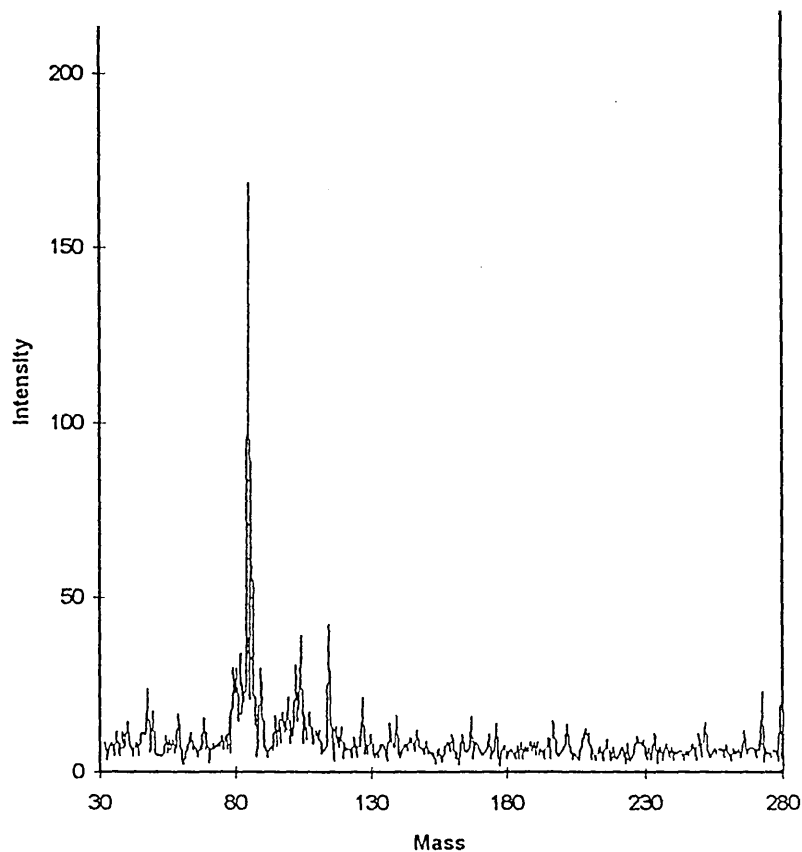

Fig. 18 Mass spectrum over the range 30-280 amu for $\text{Cr}(\text{NO}_3)_3$ ($10\mu\text{l}$, 10ppm), taken a few seconds after the vaporisation step.

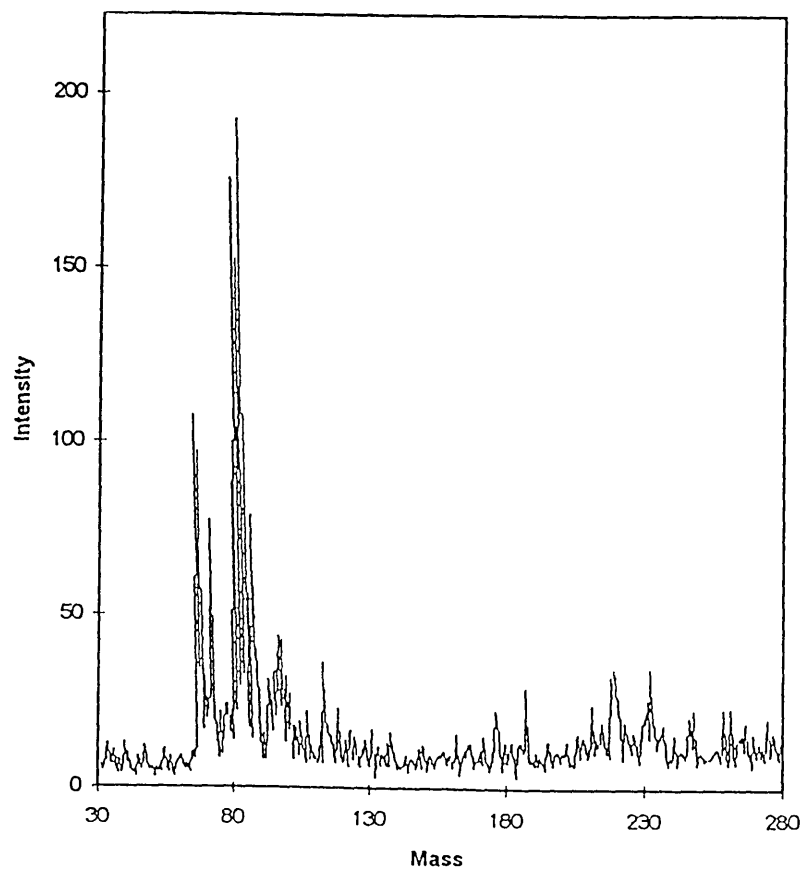

Fig. 19 Mass spectrum over the range 30-280 amu for CrO_3 ($10\mu\text{l}$, 10ppm), taken a few seconds after the vaporisation step.

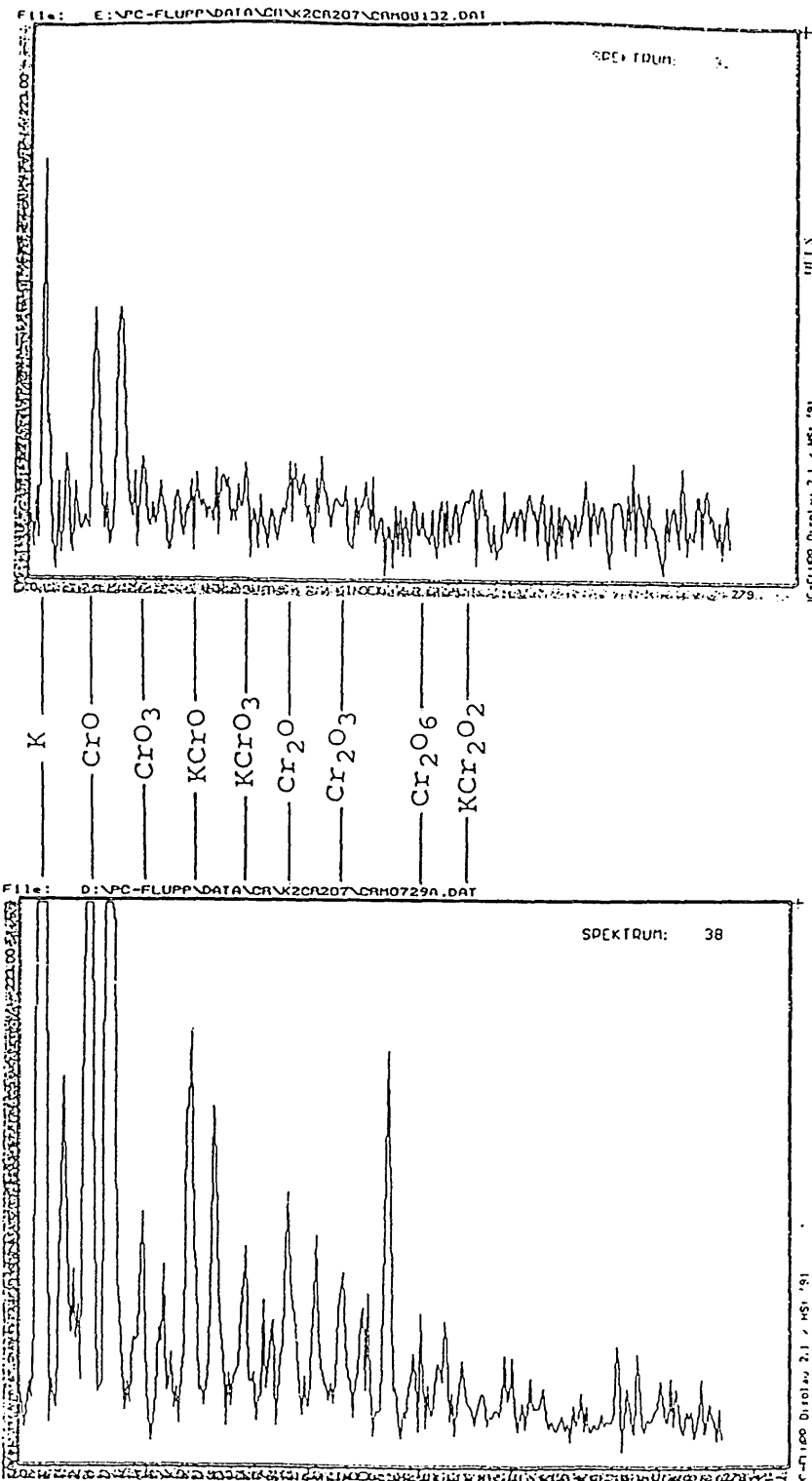

Fig. 20 Comparison of the spectra of dionised water (10 µl) with K₂Cr₂O₇ (10 µl, 10 ppm), a few seconds after the vaporisation step.

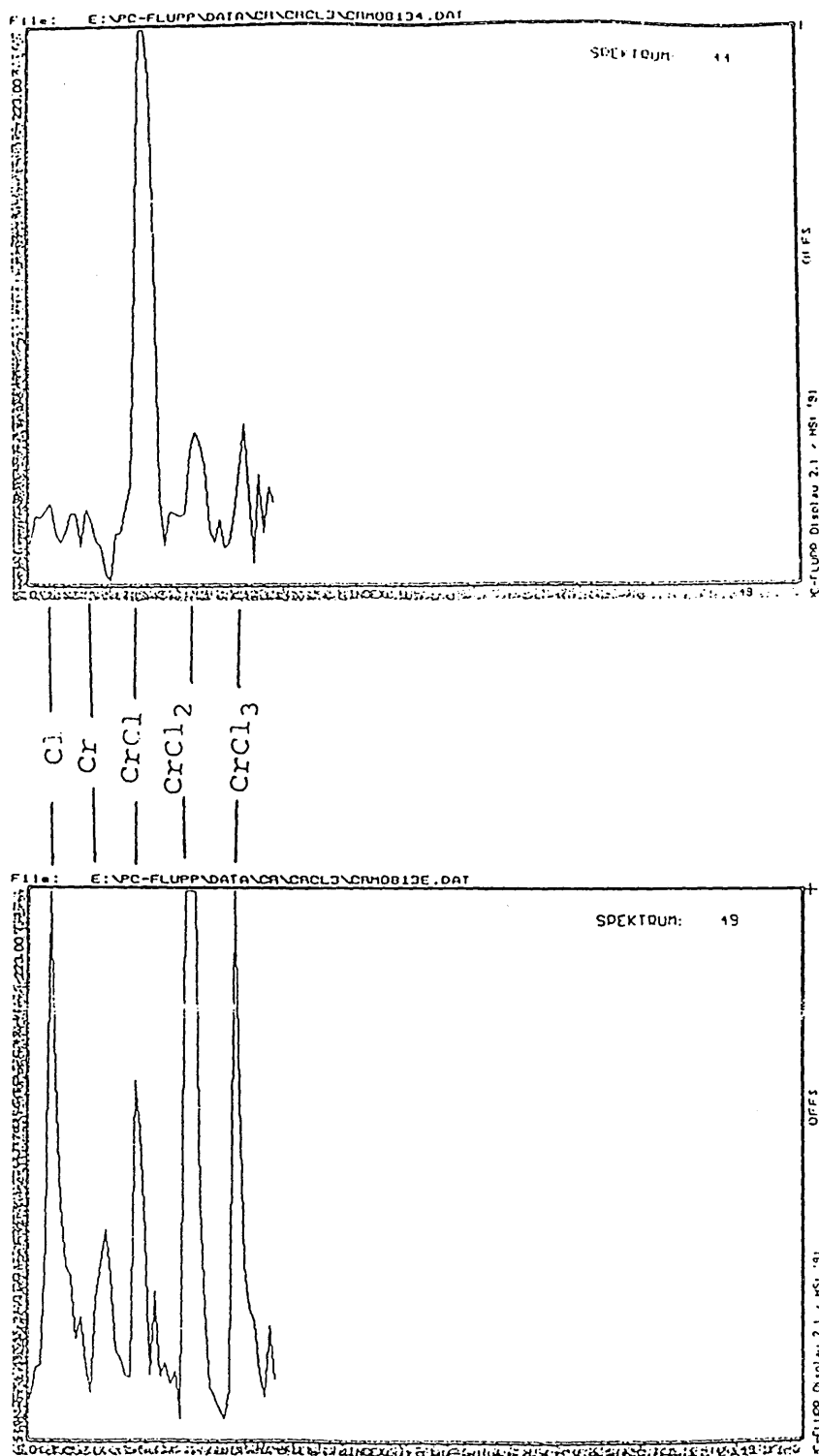

Fig. 21 Comparison of the spectra of dionised water (10 μ l) with CrCl_3 (10 μ l, 10 ppm), a few seconds after the vaporisation step.

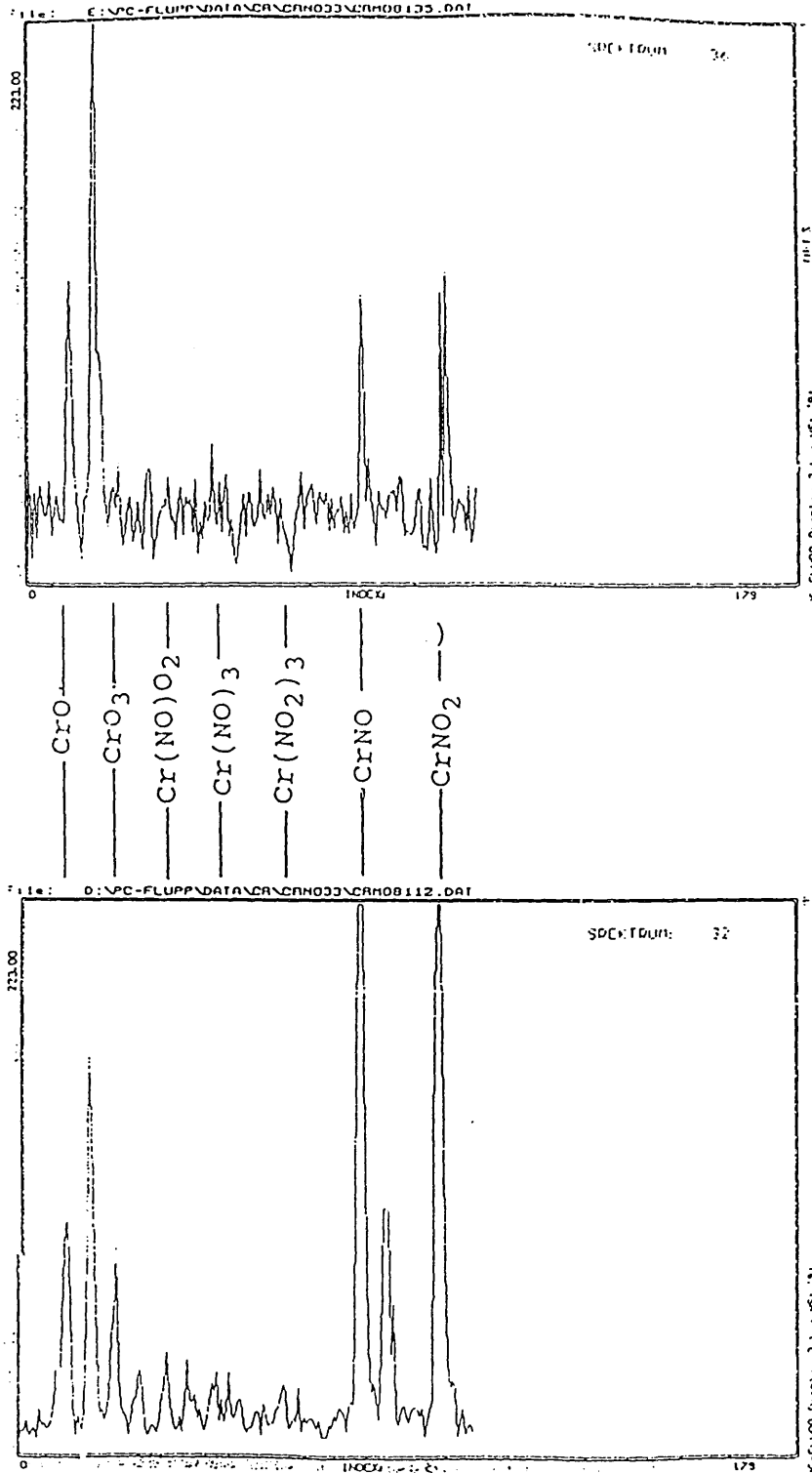

Fig. 22 Comparison of the spectra of dionised water (10 μ l) with Cr(NO₃)₃ (10 μ l, 10 ppm), a few seconds after the vaporisation step.

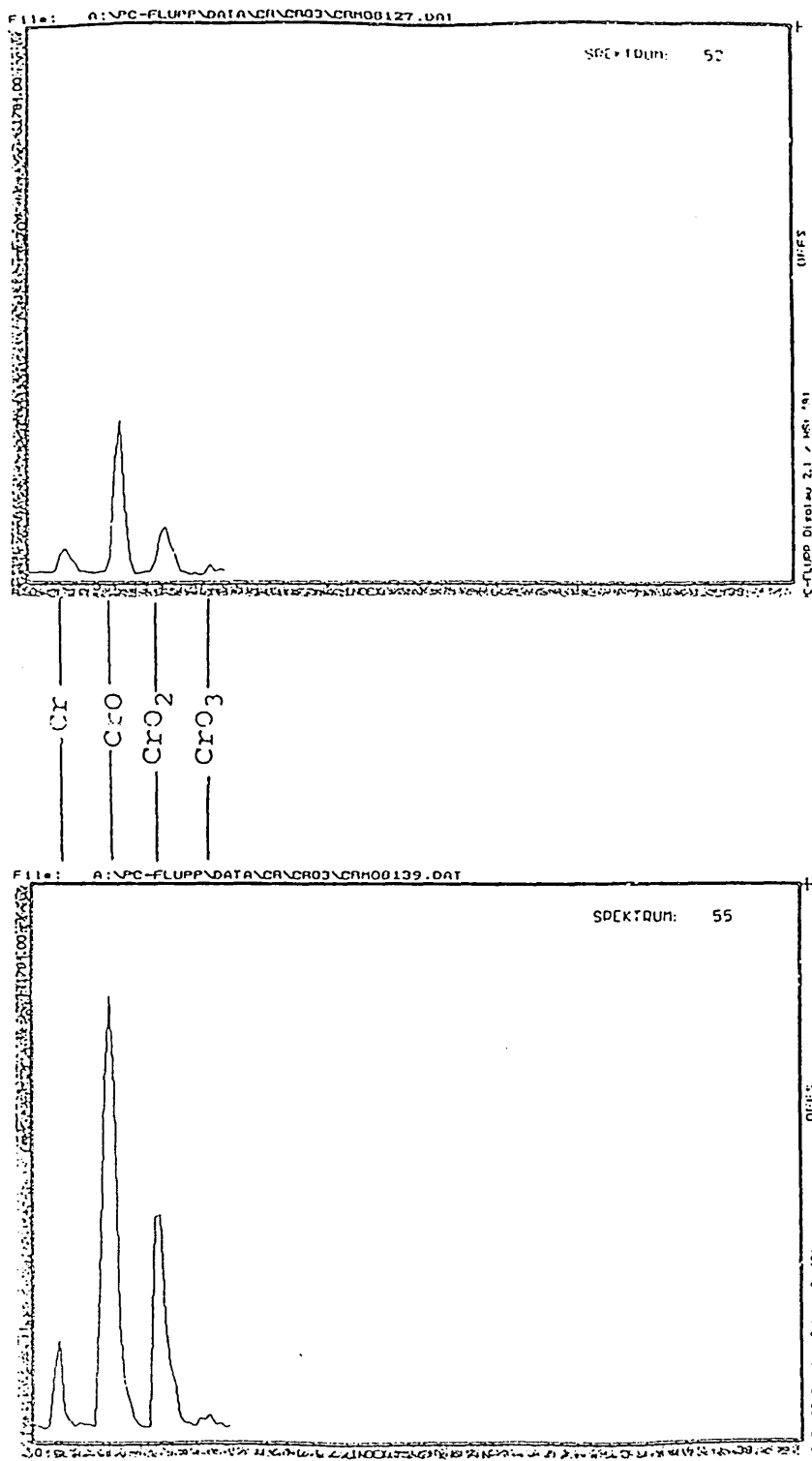
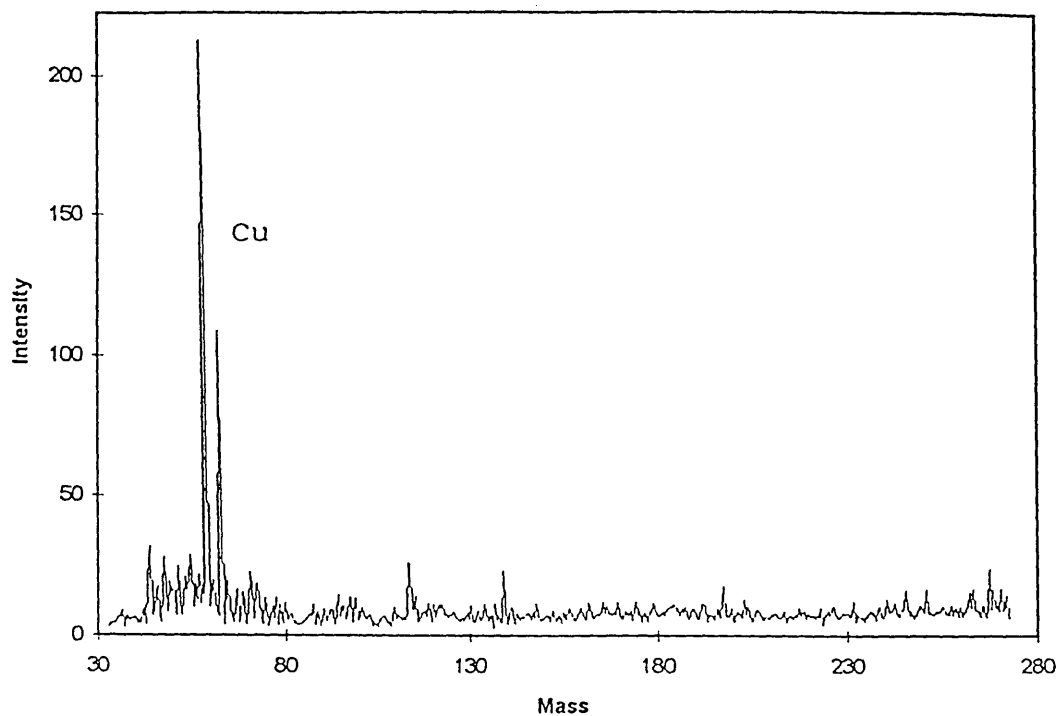

Fig. 23 Comparison of the spectra of dionised water (10 μ l) with CrO₃ (10 μ l, 10 ppm), a few seconds after the vapourisation step.

4.3.2. Chromium - Copper mixtures

To test the instrument when more than one compound is present, a simple solution was prepared containing two known compounds. The mass spectra were taken for a 10 ppm solution of chromium (III) chloride and a solution of 10 ppm copper (II) nitrate (fig. 24). The two solutions were mixed together and a 10 μ l aliquot of the resulting mixture was measured on the ETV-ToF-MS to see if the original two molecular species could be observed during the vaporisation process (fig. 25). Molecular species could be seen, but quite different from the starting spectra, these suggested the presence of copper (I) chloride and a different chromium species, obviously the two compounds have reacted and the chromium has reduced the copper. These spectra show the possibility the ToF-MS to show what compounds are present in a solution, it also indicates the very complicated spectra that would be obtained from an unknown sample.

(a)



(b)

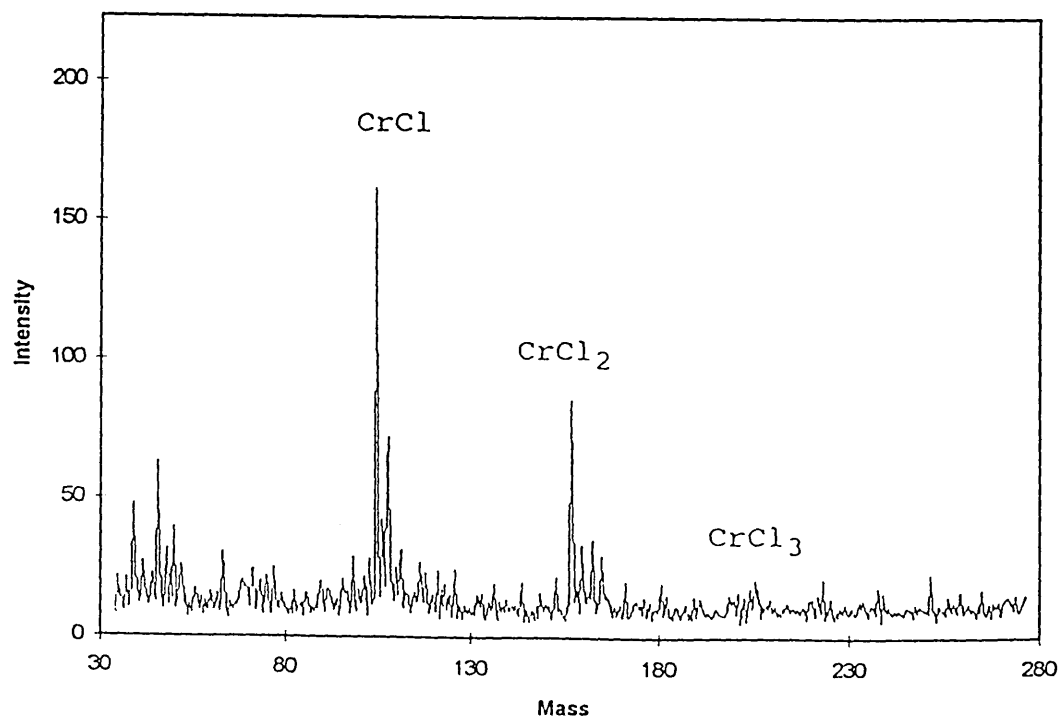

Fig. 24 Scan of the mass range 30-280 amu while vaporising (a) Copper (II) Nitrate (10ppm, 10 μl) and (b) Chromium (III) Chloride (10ppm, 10 μl).

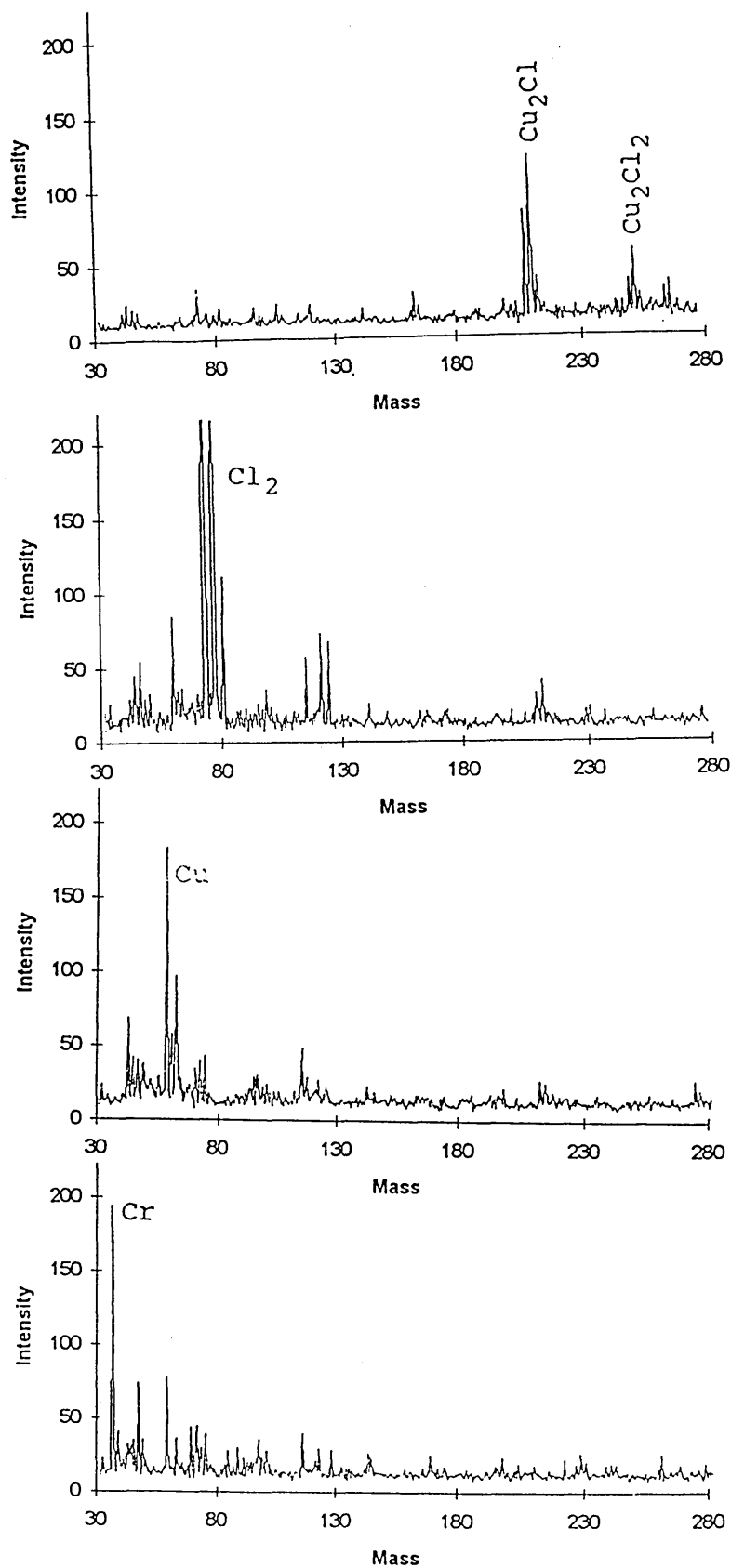

Fig. 25 Mass scans of the range 30-280 amu taken during the vaporisation of the mixture of copper nitrate and chromium chloride (10 μl). Each spectra has a 0.15 seconds difference.

4.4. Conclusion and Future Work.

Studies using the Spectro M.S. time-of-flight mass spectrometer have shown that this instrument can provide a very useful service to analytical chemistry. It will have the power to analyse very small amounts of sample with very low levels of detection and has been proposed as a means of single atom detection. Further work still has to be carried out to improve its limit of detection, mainly by a better means of sample introduction and also by a simultaneous data acquisition system. The inductively heated graphite cup seems to be the best means for increasing the amount of sample introduced into the source, this would however require a lot more shielding to prevent the r.f. from interfering with the MCP detector and a better means of connecting the cup into the system to prevent any vacuum lost. The design of the source may have to be improved to prevent source saturation and so improve the dynamic range of the system and prevent the spectrum from disappearing, this would also be true for when solids are analysed due to the high number of atoms that would be created during vaporisation and subsequent lost in vacuum pressure, more efficient pumping systems are required. If the analysis of heavy atoms or molecules is to be performed, a means of post detection acceleration will be required to ensure that the atom or molecule has enough energy to cause amplification in the microchannel plate detector.

There are many samples which are difficult to analyse by conventional methods since most sample preparation procedures can destroy species information - that could benefit from this instrument i.e. Cr(VI) in glass where all speciation data would be lost in sample preparation. Therefore more work needs to be carried out to see how much molecular information can be acquired by careful manipulation of the instrument parameters.

With current legislation requiring the measurement of heavy metals and toxic elements at even lower levels, there is a need to ensure that blank values are as low as possible, the current problem with this ToF instrument is the underlying blank spectrum caused by fragments of the rotary vacuum pump oil. This could however easily be improved by

means of a cold trap then the limits of detection for the ToF would then improve markedly.

The work on chromium-copper mixtures has shown that it is possible to see where possible contaminants are coming from by observing the molecular species present. More work does have to be performed on this form of analysis, the use of a graphite cup may allow more sample to be used and better heating programmes to be utilised in the hope of preventing dissociation of the molecules during vaporisation. This dissociation of the molecules during the heating stage and the poor transport efficiency of the tungsten coils are the major setbacks while trying to obtain molecular information.

4.5. References.

- [1] Leybold-Heraeus GmbH and Co., Cologne, Germany.
- [2] Cambridge Mass Spectrometry Ltd., East Bridge House, Saxon Way, Bar Hill, Cambridge, CB3 8SH, UK.
- [3] F. Adams and T. Manney, *Adv. Mass Spectrom., Part A*, 1986, **10**, 507.
- [4] D. W. Beekman, T. A. Callcot, S. D. Kramer, E. T. Arakawa, G. S. Hurst and E. Nussun, *Int. J. Mass Spectrom. Ion. Phys.*, 1980, **34**, 89.
- [5] T. Signal and K. Ledingham, *New Sci.*, 1987, **26**, 52.
- [6] J. Kissel, *Adv. Mass Spectrom., Part A*, 1986, **10**, 175.
- [7] B. T. Chait and K. G. Standing, *Int. J. Mass Spectrom. Ion. Phys.*, 1981, **40**, 185.
- [8] K. G. Standing, R. Beavis, G. Bolbach, W. Eng, F. Lafortune, D. Main, B. Schueler, X. Tang and J. B. Westmore, *Anal. Instrum.*, 1987, **16**, 173.
- [9] R. D. Macfarlane and D. F. Torgerson, *Int. J. Mass Spectrom. Ion. Phys.*, 1976, **21**, 81.
- [10] R. D. Macfarlane, *Anal. Chem.*, 1983, **55**, 1247A.

A variety of novel strategies and techniques have been used to perform speciation studies. Flow analysis systems were devised which allowed the speciation of selenium to be performed. The combination of laser ablation with crossed immunoelectrophoresis provided the capability to both identify and quantify protein-metal complexes. Finally, the new technique of electrothermal vaporisation - time of flight - mass spectrometry, provided the opportunity to perform either trace elemental analysis or speciation analysis by alternating instrument parameters.

Flow analysis studies indicated that the selenium(IV) and selenium(VI) species interact differently with activated alumina and sulphhydryl cotton fibre. Differences in the binding strength of the two selenium species with acidic activated alumina were thus exploited to perform speciation analysis. Unfortunately, the extremely high binding strength between selenium(IV) and acidic activated alumina makes it very difficult to elute. This extra binding strength is caused by covalent bonding between the selenium and the alumina. Selenium(VI), having no lone pairs of electrons, does not form this covalent bond but only undergoes an adsorption/exchange mechanism with the alumina. Further studies are required to discover an eluent which is capable of breaking the strong covalent bond formed between the alumina and selenium(IV) while not damaging the microcolumn or the instrumentation used. However, the use of a microcolumn of activated alumina improved sensitivity for selenium(VI) by ICP-MS from 4 µg/l to 8 ng/l, a 500 fold improvement.

Sulphhydryl cotton fibre, under acidic conditions showed its selective affinity for the selenium(IV) species. This is due to the thiol bonds being susceptible to nucleophilic attack. Again it is the lone pair of electrons on selenium(IV) which causes the difference in bonding. Selenium(VI) is not a nucleophile and therefore, cannot form a bond with

the sulphur groups on the sulphhydryl cotton fibre. Selenium(VI), therefore, passes straight through the microcolumn to the detector while the selenium(IV) reacts with the sulphur groups and is bound to the microcolumn. Injection of OH^- in the form of ammonium hydroxide breaks the bond thus releasing the selenium(IV) into the carrier stream where it passes to the detector. This system can be used to preconcentrate selenium(IV) in the same way as the alumina microcolumn is used to preconcentrate selenium(VI). This system gives an improvement in the detection limit of selenium(IV) to 15 ng/l.

As both the alumina microcolumn manifold and the sulphhydryl cotton fibre manifold are run under the same conditions, i.e. carrier 0.01M HNO_3 , eluent 0.1M NH_4OH , this allows us to combine the two columns to preconcentrate and speciate both selenium species. This in theory should allow the analysis of both species in the ng/l range using microcolumn preconcentration with ICP-MS incorporating ultrasonic nebulisation for sample introduction.

The use of two microcolumns may provide speciation schemes for other elements. Both inorganic arsenic species, As(III) and As(V), are retained on acidic activated alumina. However, it proved very difficult to remove the As(III) species from the alumina. Early studies with sulphhydryl cotton fibre microcolumns have shown that under neutral conditions, As(III) is retained on the microcolumn while As(V) passes through the microcolumn. A flow injection manifold with a neutral sulphhydryl cotton fibre microcolumn and an acidic alumina microcolumn will allow the preconcentration/separation of both arsenic species.

Early studies using laser ablation - ICP - mass spectrometry in combination with crossed immunoelectrophoresis to determine trace element levels in proteins have shown the

technique to be very promising. As the gels can be prepared containing known amounts of trace elements, perfectly matrix matched standards can be prepared for calibration. The localised analysis of laser ablation, is well suited to determining the separated protein peaks on the crossed immunoelectrophoresis gel.

Although these studies have shown that the detection limits achieved were insufficient to determine "real" element levels. Recent advances in ICP-mass spectrometry have improved detection limits by approximately 50 fold over the PlasmaQuad II+ instrument used in these studies. Modern u.v. laser systems are also available, which give a much more controllable interaction between the laser energy and the gel, allowing for a more efficient ablation process. These advances in instrumentation would allow for greater resolution in the mapping. Since mapping using laser ablation can be performed in less than a day, compared to up to 2 weeks for autoradiography, this process shows real promise.

The novel technique of coupling electrothermal vaporisation with time-of-flight mass spectrometry, captures the imagination as a technique for performing not only elemental analysis, but also speciation analysis. However, the full potential of this technique was as yet not fulfilled. The data acquisition system, working in a sequential mode, removed any advantage of using time-of-flight mass spectrometry, which offers us the ability of acquiring a full mass spectrum simultaneously. The use of tungsten coils heated by a poor electrothermal vaporisation device further reduced the capabilities of the system. The tungsten coils only introduced approximately 0.3% of the sample to the ion source compared to the 80-100% that would be desirable. If improvements in these two areas can be made, electrothermal vaporisation time-of-flight mass spectrometry may prove to be a very powerful technique.

The process of identifying and quantifying the different, defined species, forms or phases present in a material is becoming more important. More research time and money is being spent on developing methods and techniques for performing speciation analysis. This in turn will lead to a greater understanding of the effects of the different elemental species on the environment and to legislature demanding the analysis of specific species.