

An integrated TQM approach for the development of medium size organisations.

FIELD, Richard D.

Available from Sheffield Hallam University Research Archive (SHURA) at:

<http://shura.shu.ac.uk/19648/>

This document is the author deposited version. You are advised to consult the publisher's version if you wish to cite from it.

Published version

FIELD, Richard D. (1996). An integrated TQM approach for the development of medium size organisations. Masters, Sheffield Hallam University (United Kingdom)..

Copyright and re-use policy

See <http://shura.shu.ac.uk/information.html>

ProQuest Number: 10694529

All rights reserved

INFORMATION TO ALL USERS

The quality of this reproduction is dependent upon the quality of the copy submitted.

In the unlikely event that the author did not send a complete manuscript and there are missing pages, these will be noted. Also, if material had to be removed, a note will indicate the deletion.

uest

ProQuest 10694529

Published by ProQuest LLC(2017). Copyright of the Dissertation is held by the Author.

All rights reserved.

This work is protected against unauthorized copying under Title 17, United States Code
Microform Edition © ProQuest LLC.

ProQuest LLC.
789 East Eisenhower Parkway
P.O. Box 1346
Ann Arbor, MI 48106- 1346

**AN INTEGRATED T.Q.M. APPROACH
FOR THE DEVELOPMENT OF
MEDIUM SIZE ORGANISATIONS**

RICHARD D. FIELD O.B.E.

A thesis submitted in partial fulfilment of the
requirement of
Sheffield Hallam University
for the degree of Master of Philosophy.

July 1996

	Page
ABSTRACT	4
ACKNOWLEDGEMENTS	5
LIST OF TABLES	6
LIST OF ILLUSTRATIONS	8
CHAPTER	
I. INTRODUCTION	
1.1 Background	10
1.2 Motivation for Research	11
1.3 Problem Description	12
1.4 Objective	13
1.5 Research Methodology	14
II. ROLE OF TRAINING & ENTERPRISE COUNCILS (TECS)	
2.1 What are TECs and why were they set up?	19
2.2 What are TECs responsible for?	21
2.3 Who are the customers of TECs?	22
2.4 How TECs work with Government	23
2.5 The National Education and Training Targets	24
2.6 Why TECs were chosen for this research	25
III. TOTAL QUALITY MANAGEMENT PRINCIPLES AND CORE CONCEPTS	
3.1 Historical development of Quality Management	26
3.2 Total Quality Management Authorities	28
3.3 Comparisons	66
3.4 Principles of TQM	70
IV. CREATION OF THE QUESTIONNAIRE	
4.1 Areas addressed	100
4.2 Structure of Interviews	101

V.	RESULTS OF INTERVIEWS	
5.1	Introduction	105
5.2	Leadership	105
5.3	Loyal Customers	117
5.4	Teamwork	120
5.5	Management by Fact	125
5.6	Continuous Improvement	129
VI.	GENERAL CONCLUSIONS	
6.1	Leadership	133
6.2	Loyal Customers	137
6.3	Teamwork	140
6.4	Management by Fact	142
6.5	Continuous Improvement	146
VII	SPECIFIC CONCLUSIONS AND RECOMMENDATIONS	
7.1	Conclusions	149
7.2	Summary Recommendations	150
VIII	FURTHER RESEARCH NEEDED	
8.1	Update	153
8.2	Customers	153
8.3	Best Practice	153
8.4	TQM Organisation	153
8.5	Motivation	154
	APPENDIX A	155
	APPENDIX B	156
	REFERENCES	159

AN INTEGRATED T.Q.M. APPROACH FOR THE DEVELOPMENT OF MEDIUM SIZE ORGANISATIONS

ABSTRACT

TQM is seen to be a key ingredient in the working of some of the most successful companies in the world. Awards for these companies include 'The Deming Award' in Japan, 'The Baldrige Award' in America, the 'EFQM Award' in Europe, and the UK has also recently launched 'The U.K. Quality Award'. This thesis serves to lay a foundation for investigating quality in medium size organisations; where, with management understanding, there is potential to comprehensively implement such strategies and thereby enhance those organisations.

In this thesis I have considered TECs as medium-size organisations. In order to develop a TQM approach for TECs I have considered a number of TQM authorities and compared their principles with the European Quality Award (EQA) model in order to develop a model suitable for TECs.

In the process of this comparison work it was realised that the EQA model was too complex for this particular application. Hence, I have developed a simpler TQM model which also incorporates all the characteristics of the EQA model.

With the help of this model and personal interviews, data was gathered in order to test the suitability of the model and to identify critical success factors with medium-size organisations.

The results, in general, indicate that there is a high calibre of management and staff, within the organisations visited, but with little understanding of TQM concepts. However, there were examples of 'good practice' and strong processes. Recommendations are set out detailing the kind of quality strategies medium-size organisations could adopt to enhance their effectiveness.

ACKNOWLEDGEMENTS

My sincere thanks and appreciation to all those who contributed to this research effort. In particular: Professor Gopal Kanji for his endless persistence and patience, wisdom, guidance and sense of humour which he has needed in abundance!

Professor Gareth Roberts for inspiring me to start this research, his clarity of vision, his genius at being able to explain, simply, the most complex of matters, and his encouragement when there seemed no end in sight.

Pippa Field who has had the ‘patience of Job’ and the sense of humour to match it, as I spent nights and weekends hidden in my study.

Jenny Parkin for her constant belief that I could really complete this work, often when I didn’t believe it myself. And for her help and advice in making this report look structured and professional.

John Carlisle, Peter Field, Mike Pupius and my other friends whose encouragement, knowledge, wisdom and sense of humour have pulled me through.

Richard D. Field O.B.E.
Research Student
School of Computing &
Management Sciences
Sheffield Hallam University

LIST OF TABLES

Table		Page
1	Comparison of AESOP with the EFQM model	30
2	Comparison of CONWAY with the EFQM model	33
3	Comparison of CROSBY with the EFQM model	37
4	Comparison of DEMING with the EFQM model	44
5	Comparison of FEIGENBAUM with the EFQM model	50
6	Comparison of ISHIKAWA with the EFQM model	54
7	Comparison of JURAN with the EFQM model	58
8	Comparison of KANJI/ASHER with the EFQM model	62
9	Comparison of TAGUCHI with the EFQM model	65
10	Comparison of TQM PRINCIPLES with the EFQM model	67
11	Number of TQM Principles Included	106
12	Knowledge of Organisation's Vision, Mission, Strategic Objectives and Values	107
13	Comparison of Chief Executives and their staff's perceptions of their organisations' values	109
14	Chief Executives perception of the effectiveness of their organisation's Policy and Strategy	111
15	Feeling of ownership of Policy and Strategy by staff	112
16	Effectiveness of Policy and Strategy communication	116
17	Feeling of appreciation	120

LIST OF TABLES

Table		Page
18	Methods of motivation against beliefs of staff upon how they perceive that they are motivated	121
19	Evaluation and improvement of communications effectiveness	123
20	Policy and Strategy reflected in business plans	125
21	Effectiveness and relevance evaluated of Policy and Strategy	127
22	Link between Policy and Strategy, and drive for excellence	129
23	Formal Leadership and Communication/Teamwork training	130

LIST OF ILLUSTRATIONS

Figure		Page
1	Traditional organisation chart	10
2	Production viewed as a system	39
3	Kanji's Pyramid of TQM	61
4	EFQM Model	68
5	Interdependence between 5 TQM principles	71
6	Graphical comparison of the author's TQM principles with the EFQM model	72
7	The Leadership Triangle	75
8	The Maturity Model	79
9	The Quality Circle	82
10	The Shewhart or Deming Cycle	84
11	Combination of figures 2 and 5	85
12	Spheres of Influence	86
13	Organisation Tree	87
14	A Sense of Mission comes from a Values Match	88
15	What a Leader has to do	89
16	A Briefing Sheet	91
17	Speaking Engagement decision-making flow chart	95
18	Ishikawa Diagram	96
19	Review Tool	99
20	Number of TQM Principles Included	106
21	Knowledge of Organisation's Vision, Mission, Strategic Objectives and Values	107

LIST OF ILLUSTRATIONS

Figure		Page
22	Comparison of Chief Executives and their staff's perceptions of their organisations' values	110
23	Chief Executives perception of the effectiveness of their organisation's Policy and Strategy	111
24	Feeling of ownership of Policy and Strategy by staff	113
25	Effectiveness of Policy and Strategy communication	116
26	Feeling of appreciation	120
27	Methods of motivation against beliefs of staff upon how they perceive that they are motivated	122
28	Evaluation and improvement of communications effectiveness	123
29	Policy and Strategy reflected in business plans	125
30	Effectiveness and relevance evaluated of Policy and Strategy	127
31	Link between Policy and Strategy, and drive for excellence	129
32	Formal Leadership and Communication/Teamwork training	131
33	Knowledge model	152

CHAPTER ONE: INTRODUCTION

1.1 BACKGROUND

We are in an era of intense international competition where wealth, technology and knowledge are the three legs, of a three legged table, underpinning the vibrance of economies worldwide (Toffler 1990). Money and technology can be transferred around the world at the touch of a computer button, thus it is only our knowledge which keeps business in a geographical area in the medium/long-term.

Knowledge covers not only knowledge of products and processes; but also knowledge of customers' needs and how to fulfil those needs with the best possible quality, service and cost.

The realisation of these basic facts cannot be achieved with our traditional organisation structures (see Fig. 1, page 10), set up by function, which look after the needs of our superiors.

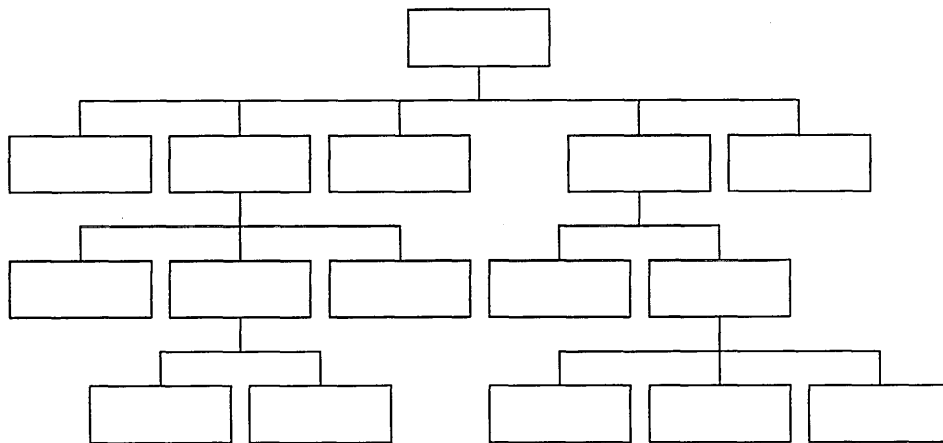

Fig. 1 - A traditional hierarchy chart of organisations (Scholtes 1988).

Structures and processes must be aligned towards our clearly defined customers - (see Fig.2, page 39).

Such fundamental knowledge is all part of an holistic approach to business, known as Total Quality Management (TQM): it is a common sense philosophy, a set of guiding principles combined with some effective tools which, together, can be seen as 'best practice' in organisations.

1.2 MOTIVATION FOR RESEARCH

Bearing the above factors in mind, this research is specifically aimed at identifying the key principles and actions which a leader and his/her team of a medium-size organisation might take, which would create an excellent business with an enhanced probability of survival and growth in this rapidly accelerating world of change in which we live.

TQM cannot be implemented without the involvement of every member of an organisation because it needs to transform the very culture of that organisation: 'patting people on the back' and encouraging them is necessary, but motivation needs more than mere exhortation (Kondo 1989) it needs more than rewards (Kohn 1993) it needs an overall philosophy and implementation strategy.

We, in Britain, need to understand - thoroughly - this philosophy; for Japan's rapid rise to economic dominance is largely credited to the application of TQM: on my visits to Nissan (UK) and Komatsu (UK), both used TQM processes throughout their organisations to enhance production

and reduce costs. They are both simple and highly disciplined, leading to little variation.

Increasing evidence of its effectiveness is now emerging in Western businesses for example, in Shell - where in its Dutch subsidiary, NAM; £25 million a year is being saved in drilling well costs in the North Sea using these processes (Go Ahead 1995).

TQM is, in my opinion, simple formalised common sense, it is used by many of the most successful organisations around the world; for example, Rank Xerox, who won the EFQM Award in 1992 and, as the EFQM Award is based upon key principles and core concepts, there must be some lessons to be learned for medium size organisations.

1.3 PROBLEM DESCRIPTION

Management has grown up in Britain becoming successful through working with systems and within structures which are similar to those that have been in place since the start of the Industrial Revolution - 'so why change a way of working that has been successful in getting us to the position that we are today?' Perhaps because 'you will not solve the significant problems that you have using the same thought processes that you gave those problems in the first place' - Albert Einstein.

The RSA's Inquiry Tomorrow's Company: 'The Role of Business in a Changing World' gives the answer when it states that seventy per cent of UK companies believe that they are world class yet only two point three per cent are! (RSA 1995).

We, British leaders of organisations, have been amateur in our approach, and have had an intrinsic complacency towards business that stretches back into the 1800s according to Correlli Barnett. For example, in the 1940s there was a 'scarcity of well-trained and high quality management' which led to appalling industrial relations (Barnett 1986)

Even now the 'average' British manager reads fewer than one management book a year and just seven days training a year is seen as excellent! On frequent surveys of business audiences, I find that fewer than ten per cent read or listen to any business books at all! The idea of the 'gifted amateur' rather than the 'practical man' is still with us in Britain - only a change in culture will alter this - TQM's philosophy insists upon leadership's education, understanding, permanent commitment and constancy of purpose towards continuous improvement, amongst other principles (Deming 1986).

1.4 OBJECTIVE

There are a great many books on TQM: its philosophy, tools and techniques. Bearing in mind how little British management reads; and also how difficult to read some of these books can be, are there some clear simple processes, which could be shared with fellow managers, that if adopted would considerably enhance a medium size organisations long-term effectiveness?

The objective of this research then has been to:

1. Understand the philosophy, principles, core concepts, tools and techniques of TQM.

2. Clarify the present position of medium size organisations in the use of TQM with special reference to TECs.
3. Draw out 'practical' lessons from this research.
4. Recommend simple key processes that can be adopted by medium size organisations to enhance their operations and help to develop business excellence.

1.5 RESEARCH METHODOLOGY

Introduction

After gaining a basic understanding of TQM through reading, attending presentations and courses, visiting organisations in the USA and UK, and listening to practitioners; ten medium size organisations were selected for further research. These ten organisations consisted of nine Training and Enterprise Councils (TECs) and their Regional Office. These were ideal, for they were newly formed with new, or relatively new, chief executives; selected for their proven leadership qualities. They were all relatively the same size - between 50 and 100 staff - and represented all the TECs in one region of England. Being connected with both the Government and many local organisations, it was of prime importance that these organisations should be and be seen to be encompassing best practice!

The Research Method

Each chief executive agreed to be interviewed by me, either on their own or accompanied by their quality manager. At that meeting, which lasted one and a half to two hours, the questionnaire was completed in full. Also,

in every case the chief executive agreed to allow me to interview three staff picked at random: one member of the 'top team', one 'middle manager' and one 'junior' member of the team. In almost every case, each person was from a different function within the organisation.

These 'staff interviews' were completed on the same day as those of the chief executive and were carried out in private by myself. Every team member co-operated fully in this research.

Use of the EFQM model and adoption of the TQM star model

In order to undertake this quality assessment and to have a touchstone that can be used by medium-size organisations, it has been necessary to find or develop a simple yet comprehensive quality framework.

My approach has been to compare the TQM principles of various experts with the European Quality Award (EQA) criteria which, to many people is an ideal framework for Total Quality Management. This award was designed after a considerable consultation exercise was carried out across Europe, and building upon both the Deming Award of Japan and America's Baldrige Award.

Although this exercise showed the EQA to be comprehensive; for the purpose of assessing medium-size organisations and future use of a model by them, I felt that a simpler model must be made available. - see pages 16 and 71.

Development of the Survey

The survey questionnaire was based upon just one of the five interdependent points of my star model, that of Leadership - see page 71. The Leadership point incorporates two of the nine areas laid out in the European Quality Award model, namely: Leadership, and Policy and Strategy - see page 68.

The reason for focusing on these two areas, and linking back to Section 1.2 Motivation for Research, is because Leadership is the driving force within every organisation and Policy and Strategy is the first step in the process of giving direction and a culture which establishes an effective organisation. It will also uncover the Leader's awareness of TQM principles, tools and techniques.

Coverage of the survey

There are eighty-two TECs in England in ten geographical areas, so eleven per cent of all TECs were surveyed or ten per cent of the regions.

The answers from every one of those surveyed, forty people in total, are included in this report.

Method of survey

Surveys were carried out in the second and third quarters of 1993. This was done by a personal visit to the location of each TEC.

Prior to the visit, a meeting was set up by phone with each chief executive. These were confirmed in writing.

After the visit, 'thank you' letters were written within a day to the forty interviewees.

In the final quarter of 1993, each chief executive was revisited and initial findings shared with him and any of his team that he had invited to the meeting - incidentally all chief executives were male - see Appendix A (page 155)

Response rate

As stated above, because these interviews were 'face to face'; one hundred per cent of the forty interviewees agreed that their answers could be included in this survey.

It was agreed that the identity of both the TECs and team members should be kept confidential.

STRUCTURE OF THESIS

The structure of this work has followed the steps:

Following the introduction in Chapter one, Chapter two discusses a variety of aspects of TECs. Chapter three then looks at the principles and concepts of various TQM authorities and compares these with the European Quality Award model, in order to have a clear understanding of the authorities and the EQA model, also to develop a simple model. The reason for this is that the newly formed TECs and other medium-size organisations would find it very difficult to comprehend the complexities of the EQA model.

Chapter three also develops this simplified model and shows the relationship with the EQA model. It also discusses each of the five principles in detail.

In Chapter four the questionnaire was developed on the basis of the five principles of the star model. Chapter 5 provides the findings of the forty interviews of Chief Executives, Senior and Junior Managers and Junior staff of TECs.

Chapter six sets down the findings and recommendations using the five principles of the star model.

Chapter seven provides specific conclusions and summary of recommendations whereas chapter eight suggest further research needed in this area.

CHAPTER TWO:

TRAINING AND ENTERPRISE COUNCILS

2.1 WHAT ARE TECS AND WHY WERE THEY SET UP?

TECs are independent companies - limited by guarantee - led by the (sixty-seven per-cent) local business people, other than this proviso there are few restrictions upon the make-up of the Board.

The Government's stated intention when they set up the TECs, and this has actually been the case, was that local people should play a greater role in the provision and development of the training, education and enterprise programmes in their respective areas rather than this continuing to remain as another Government department.

The reasons for this fundamental move were threefold, which are given below.

1. Surveys showed that Britain was falling behind its major competitors in the education and training of its workforce (Barnett 1986) - the providers of the wealth upon which our country's standard of living relies. According to Correlli Barnett (1986) in his book 'Audit of War', this downward trend started in the eighteen-nineties!

2. The Government's advice was that local people and organisations would be more in touch with what was needed locally to help the local community fulfil its potential. It was felt that local input would mean that the level of provision would be improved, so that young people and adults would be trained in line with the needs of local companies, to provide a better qualified workforce with the necessary skills to contribute to the growth and development of local businesses. Other services aimed at helping local businesses to set up and develop would also be better targeted with more local input. There was also a desire of the Government to gain more local sponsorship for these initiatives.

3. Chambers of Commerce were the natural choice of bodies to administer this task; they are spread throughout the Great Britain and, just as important, the European model of training uses local Chambers to good effect. However, the Government decided against this route mainly because the quality of our British Chambers of Commerce varies from being excellent to being very weak; there were just too many weak ones for the Government to be willing to take such a significant risk with this major initiative.

2.2 WHAT ARE TECs RESPONSIBLE FOR?

They are responsible, under contract with the Secretary of State, for the achievement of performance-related outputs - and a great deal more!

For they took over the work of delivering training, enterprise and temporary employment programmes which had been delivered by the Government's fifty-two Area Offices of the Employment Department's Training, Enterprise and Education Division (TEED) formerly known as the Manpower Services Commission (MSC) and the Training Agency (TA) - the head office of which was at Moorfoot in Sheffield.

Their joint role was to provide Great Britain with the skilled and enterprising workforce that it needs to sustain growth and prosperity in an increasingly fast-changing world.

In England and Wales, some eighty-two TECs were set up in 1990 - and 1991. In Scotland their counterparts are called Local Enterprise Councils (LECs). Northern Ireland provisions are looked after by the Government's Office for Northern Ireland.

Incidentally, the TECs do not normally provide training and small business assistance directly. They will, however, contract with providers to deliver services to specifications laid down by the TECs. In this way, the role of the TECs is one of ensuring that training, and assistance for local firms, match the needs of their customers and contribute to overall economic growth of their local regions.

2.3 WHO ARE THE CUSTOMERS OF TECS?

The primary customers of TECS, according to the Government, were the businesses that operate in their local areas, and local people.

Stakeholders are a much longer and more complete list:

- Companies and employer organisations

- Industry Training Organisations

- Voluntary sector and Community Groups

- Local Authorities

- Education Interests

- Trade Unions

- Employment Service

- Training providers

- Economic development interests

The TECS were, and are still, accountable to the community as a whole including the area's unemployed.

2.4 HOW TECS WORK WITH GOVERNMENT

The Secretary of State has issued guidance each year on the Government's strategic priorities. The six aims set out as Priorities for Action 1990/91 were:

1. Encouraging training by Business: To help businesses improve by encouraging them to plan and undertake training to achieve clear business aims.
2. Helping young people: To help ensure that young people acquire the skills the economy needs.
3. Helping unemployed people: To help ensure that unemployed people, and particularly the long-term unemployed, acquire the skills, experience and enterprise to help them find and keep jobs.
4. Foster Enterprise: To encourage new businesses to start and existing businesses to grow.
5. Working with Education: To help make the providers of vocational education aware of local labour market needs and to promote links between local education and employers.
6. Improving the training system: To improve the training system by ensuring that there is an effective local, sectoral and national framework. (Training Agency 1989).

2.5 NATIONAL EDUCATION AND TRAINING

TARGETS

Foundation learning

1. By 1997, 80% of young people to reach NVQ level 2 (or equivalent)
2. Training and education to S/NVQ level 3 (or equivalent) available to young people who can benefit.
3. By 2000, 50% of all young people to reach S/NVQ 3 (or equivalent)
4. Education and training provision to develop self-reliance, flexibility and breadth.

Lifetime learning

1. By 1996, all employees should take part in training or development activities.
2. By 1996, 50% of the workforce aiming for S/NVQ or units towards them.
3. By 2000, 50% of the workforce qualified to at least S/NVQ level 3 (or equivalent).
4. By 1996, 50% of medium to larger organisations to be 'Investers in People'

Footnote: Deming would probably have read this list and asked:

By what method? (an aim can only be achieved through a process).

2.6 WHY TECS WERE CHOSEN FOR THIS RESEARCH

The following were the main reasons for choosing TECs: as medium size organisations.

1. Each had been recently created - all since 1990 - and headed by leaders of businesses and organisations in the community on their boards. Thus, it was likely that this was the place to find 'best practice'.

2. Also, staff were either from the Employment Department's Training, Enterprise and Education Division (TEED) - and therefore probably well versed in the pitfalls of running small and medium-sized businesses - or specially recruited because of their expertise within training and/or business development. Again, another reason to expect 'best practice'.

3. Having been the first chairman of one of the TECs, I knew the chief executives with whom I would need to deal and they knew me. As it transpired three were new to their positions by the time a visit was arranged and undertaken.

4. I also wanted to look at how I could have done better when chairman: to share lessons learned with others and also improve my own performance in my present and future roles.

CHAPTER THREE:

TOTAL QUALITY MANAGEMENT PRINCIPLES & CONCEPTS

3.1 DEVELOPMENT OF QUALITY MANAGEMENT

The phrase Total Quality Management is a relatively new name for what is an old and well-established philosophy.

Thinking processes dating back some three thousand years ago can be read in the writings of Sun Tzu's 'Art of War' (Sun Tzu 1963) he uses many principles of TQM: for example: survival, growth and continuous improvement (in a chaotic world!), and Lao Tzu's 'Tao Te Ching' (Lao Tzu 1993), another classic of wisdom, refers to continuous improvement and competition: 'What is his secret? He never competes. So there is no one else but him.'

Systems are set down in the philosophies of Anaxagoras (500-428BC): 'Every cell of the human body carries a blueprint of the way all the other cells are constructed. So there is 'something of everything' in every cell. The whole exists in each tiny part.' (Gaarder 1991). Socrates' (470-399BC) skill in asking questions is used in Rover and Honda today: To get to the root cause use the question 'Why' five times (Brocka 1992).

Plato (428-347/BC) believed that everything flows like a system (Gaader 1991). Shewhart's cycle (Neave 1990) could be said to have come from the 'Empirical method' of observation, experience and experiment, which was developed during the Renaissance (130-150). It was Galileo Galilei who said: 'Measure what is measurable and make measurable what cannot be measured.' Johann Gottfried (1744-1803) saw history as a process. (Gaader 1991). It was only at the turn of this century that total quality was focused on systems within organisations.

The authors that follow did not all write under the heading of TQM, for example, Dr. Edwards Deming disliked the phrase and would not accept the term to cover his own work. (BDA 1991).

I have added Aesop to the list of TQM authorities, for his stories depict the philosophy of TQM, although I have not added Miyamoto Musashi (1584-1645) who was a Samurai and a great warrior, and believed that all things were interdependent, he was a Zen master 'There is no result in Zen practice. That is not the point. It is the effort you make to improve yourself that is measured.' So the philosophy of continuous improvement and systems is within Zen thinking, as it is in most religions (Ridenour 1967). Musashi also shows the power of teamwork; by working together in the fields, the farms survived (Yoshikawa 1971).

The reason, I believe, that the Japanese took to the teachings of Deming and Juran so wholeheartedly was not only that their backs were against the wall after the second world war, but also that the principles within their teachings; that of continuous improvement, for example, was in line with their own traditional Samurai culture.

So to the chosen authorities.....

3.2 TOTAL QUALITY MANAGEMENT AUTHORITIES

3.2.1 AESOP

Here are listed his core principles and a story to illustrate each (Brocka 1992):

1. *INSTITUTE TEAMWORK:*

‘United we stand, divided we all fall.’ (The four oxen and the lion). Shows the important of self-managed teams, quality circles and other uses of teamwork and shared vision.

2. *DEFINE VISION*

‘Please all and you please none.’ (The man, the boy and the donkey.) A clear vision is essential, also the serving of some customers may mean excluding others.

3 *ENSURE CREDIBLE MANAGEMENT.*

‘A liar will not be believed even when he is telling the truth - cry wolf.’ (The Shepherd boy). Trust is the foundation of an effective organisation, and to become trusted one must first become trustworthy.

4. *VALUE ALL WORK*

‘We often despise what is most useful to us.’ (The hart and the hunter). Martin Luther King said: ‘There is dignity in all work.’ Never demean workers on whom we rely or we will suffer consequences including strikes, poor productivity etc.

5 *FAIR REWARDS*

‘You may share the labour of the great but not the spoils.’ (The lion’s share). Rewards need to be fair and seen to be fair, it must also be understood how one can achieve these rewards.

6. *PERSEVERANCE WINS*

‘Perseverance wins the race.’ (The hare and the tortoise). Wisdom and cunning outmatch ambition and excitement every time! The start of the Shewhart or Deming cycle (Neave 1990) for the improvement of processes is that of planning, as it is in the story

A comparison of AESOP’s principles with EFQM model (see Table 1, page 30) shows the vital importance of Leadership, People management and Satisfaction - not only in organisations but also in our own lives. Note the clear Policies and Strategies in these simple and wise stories; although no impact on society is shown, by using these principles, there is bound to be a positive effect.

THE EUROPEAN
FOUNDATION FOR QUALITY
MANAGEMENT

		L E A D E R S H I P	P E O P L E M A N A G E M E N T	P O L I C Y A N D S T R A T E G Y	R E S O U R C E S	P R O C E S S E S	P E O P L E S A T I S F A C T I O N	C U S T O M E R S A T I S F A C T I O N	I M P A C T O N S O C I E T Y	B U S I N E S S R E S U L T S
1	TEAMWORK	/	/	/		/	/			
2	DEFINE VISION	/	/	/			/			
3	CREDIBLE MANAGEMENT	/	/	/			/			
4	VALUE AT WORK	/	/				/	/		
5	REWARDS - FAIR + UNDERSTOOD	/	/		/	/	/			
6	PERSEVERENCE WINS	/	/	/		/	/	/		
	TOTALS	6	6	4	1	3	6	2		

Table 1 - Comparison of AESOP with the EFQM model

Source: Brocka 1992

3.2.2. WILLIAM E. CONWAY.

Conway was the President and Chairman of Nashua before founding Conway Quality Inc. in 1983. His broad definitions of 'quality management' are:

'Development, manufacture, administration and distribution of consistent low cost products and services that customers want and/or need.'

And

'Constant improvement in all areas of operations, including suppliers and distributors, to eliminate waste of material, capital and time.'

What is required, he says, is a new system of management: 'people work in the system, management work on the system.' 'Management wants and needs real help - not destructive criticism.' 'The use of statistics is a common sense way of getting into specifics, statistics don't solve problems. They identify where the problems are and point management and workers towards solutions.' (Gagne 1986)

Conway believes that 85 per cent of company problems can be solved by using the following techniques: 'In less than a year, you ought to be able to perform miracles.'

- Run charts
- Flow charts
- Fishbone charts
- Pareto charts
- Histograms
- Correlation charts
- Surveys of customers

CONWAY'S SIX TOOLS FOR QUALITY IMPROVEMENT ARE:

1. HUMAN RELATIONS SKILLS

The responsibility of management to create at every level, among all employees, the motivation and training to make the necessary improvements in the organisation.

2. STATISTICAL SURVEYS

The gathering of data about customers (internal as well as external), employees, technology and equipment to be used as a measure for future progress and to identify what needs to be done.

3. SIMPLE STATISTICAL TECHNIQUES

Clear charts and diagrams that help identify problems, track work flow, gauge process and indicate solutions.

4. STATISTICAL PROCESS CONTROL

The statistical charting of a process, whether manufacturing or non-manufacturing, to help identify and reduce variation.

5. IMAGINEERING

A key concept of problem-solving, involves the visualisation of a process, procedure or operation with all waste eliminated.

6. INDUSTRIAL ENGINEERING

Common techniques of pacing, work simplification, methods analysis, plant layout and material handling to achieve improvements.

A comparison of Conway's quality management principles with the EFQM model (see Table 2, page 33), indicates the vital importance of Leadership and People management and Satisfaction, not only can this be seen, but also the need for Policies and Strategies, Resources and Customer Satisfaction. Although there is no score for either 'Impact on Society' or 'Business Results'; the EFQM model (see Fig. 4, page 68) shows how all the above achieves 'Impact on Society', and also all the above leads 'ultimately to excellence in business results'.

THE EUROPEAN
FOUNDATION FOR QUALITY
MANAGEMENT

		L E A D E R S H I P	P E O P L E M A N A G E M E N T	P O L I C Y A N D S T R A T E G Y	R E S O U R C E S	P R O C E S S E S	P E O P L E S A T I S F A C T I O N	C U S T O M E R S A T I S F A C T I O N	I M P A C T O N	B U S I N E S S R E S U L T S
		1	2	3	4	5	6	7	8	9
1	HUMAN RELATIONS SKILLS	/	/	/	/	/	/	/		
2	STATISTICAL SURVEYS	/	/	/	/	/	/	/		
3	SIMPLE TECHNIQUES	/	/			/	/			
4	STATISTICAL PROCESS CONTROL	/	/	/		/	/			
5	IMAGINEERING	/	/			/	/	/		
6	INDUSTRIAL ENGINEERING	/	/		/	/	/			
	TOTALS	6	6	3	3	6	6	3		

Table 2 - Comparison of CONWAY with EFQM model

Source: Brocka 1992

3.2.3 PHILIP B. CROSBY

Before setting up Philip Crosby Associates, he was head of the Pershing missile project at Martin Corp., it was here that he developed the concept of zero defects. He was also Director of Quality for ITT.

Crosby defines quality as ‘conformance to requirements, and it can only be measured by the cost of non-conformance.’ Don’t talk about poor quality or high quality. Talk about conformance and non-conformance. This approach means that the only standard of performance is zero defects

He states that ‘there is absolutely no reason for having errors or defects in any product.’

There are three ingredients to the ‘vaccine’ that organisations can use to prevent non-conformance:

- DETERMINATION
- EDUCATION
- IMPLEMENTATION

Crosby says that a committed management can obtain a 40 per cent reduction in error rates very quickly from a committed workforce. Also, at least half of quality problems are caused by not clearly specifying what the requirements are!

To precise his book ‘The Eternally Successful Organisation’ (Crosby 1987) an organisation should have:

- The concern for the long-term that is found in a family organisation with.

- The loyalty-producing characteristics produced in a small college, driving it along with.
- The efficiency of the professionally managed and therefore heartless corporation.

.....with all of the positive attributes and none of the negatives!

CROSBYS 14 STEPS TO QUALITY IMPROVEMENT (Brocka 1992)

1. *COMMIT TO QUALITY*

Make it clear that management is committed to quality.

2. *FORM QUALITY IMPROVEMENT TEAMS*

Form quality improvement teams with representatives from each department.

3. *MEASURE PROBLEMS*

Determine where current and potential problems lie.

4. *IDENTIFY COST*

Evaluate the cost of quality and explain its use as a management tool.

5. *RAISE AWARENESS*

Raise the quality awareness and personal concern of all employees.

6. *TAKE ACTION*

Take actions to correct problems identified through previous steps.

7. *ESTABLISH COMMITTEE*

Establish a committee for the zero defects programme.

8. TRAIN SUPERVISORS

Train supervisors to actively carry out their part of the quality improvement programme.

9. HOLD 'ZERO DEFECTS DAY'

Hold a 'zero defects day' to let employees realise that there has been a change.

10. ESTABLISH OWN GOALS

Encourage individuals to establish improvement goals for themselves and their groups.

11. COMMUNICATE OBSTACLES

Encourage employees to communicate to management the obstacles they face in attaining their improvement goals.

12. GIVE RECOGNITION

Recognise and appreciate those who participate.

13. ESTABLISH COUNCILS

Establish quality councils to communicate on a regular basis.

14. DO IT AGAIN

Do it all over again to emphasise that the quality improvement programme never ends.

A comparison of Crosby's principles with the EFQM model (see Table 3 page 37) shows not only the need for Leadership, People management and Satisfaction, Resources and Processes within effective organisations, but also that once Policies and Strategies, and Customer Satisfaction have been addressed they form an integral part of Crosby's principles and therefore do not have to be addressed by each principle. The final two EFQM principles are addressed in the comments of Table 2, page 33.

PHILIP B. CROSBY

**THE EUROPEAN
FOUNDATION FOR QUALITY
MANAGEMENT**

		L E A D E R S H I P	P E O P L E M A N A G E M E N T	P O L I C Y A N D S T R A T E G Y	R E S O U R C E S	P R O C E S S E S	P E O P L E S A T I S F A C T I O N	C U S T O M E R S A T I S F A C T I O N	I M P A C T O N S O C I E T Y	B U S I N E S R E S U L T S
1	COMMIT TO QUALITY	/	/	/						
2	FORM QTY . IMPRVMT TEAMS	/	/	/	/	/	/	/		
3	MEASURE PROBLEMS	/	/		/	/				
4	IDENTIFY COSTS	/	/		/	/				
5	RAISE AWARENESS	/	/		/	/	/			
6	TAKE ACTION	/	/		/	/	/	/		
7	ESTABLISH COMMITTEE	/	/		/	/	/			
8	TRAIN SUPERVISORS	/	/		/	/	/			
9	HOLD 'ZERO DEFECTS DAY'	/	/		/	/	/			
10	ESTABLISH OWN GOALS	/	/		/	/	/			
11	COMMUNICATE OBSTACLES	/	/		/	/	/			
12	GIVE RECOGNITION	/	/		/	/	/			
13	ESTABLISH COUNCILS	/	/		/	/	/			
14	DO IT AGAIN	/	/		/	/				
	TOTALS	14	14	2	13	13	10	2		

Table 3 - Comparison of CROSBY with EFQM model

Source: Brocka 1992

3.2.4 W. EDWARDS DEMING

Dr. Deming travelled to Japan in 1950 to help the U.S. Secretary of War conduct a population census, and was invited to lecture to top businessmen on statistical quality control. He told his audiences that they could take over the world if they followed his advice; the rest is history!

Quality, to Deming, is ‘whatever the customer needs and wants’ therefore there is a constant need for customer research. ‘Productivity improves as variability decreases. Statistical control does not imply absence of defective items, it is a state of random variation, in which the limits of variation are predictable. It is not enough to meet specification; one has to keep working to reduce the variation as well.’

‘Management’s task is to help people work smarter not harder.’

Deming believed that people who expect quick results are doomed to disappointment, he also believed that the best recognition one can give a supplier is to give that supplier more business!

His system of profound knowledge has four parts:

Systems thinking

A system is a network of interdependent components (processes) that work together to try to accomplish the aim of the system. An organisation, he states, is a system which includes customers and suppliers; it must have an aim which is understood and shared by those within it.

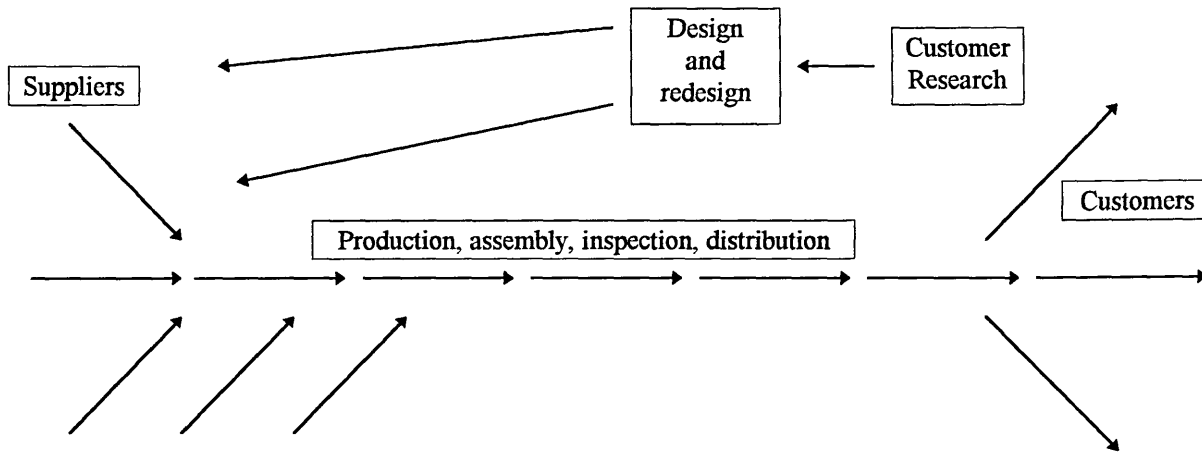

Fig 2 - Production viewed as a system (Deming 1993)

The processes within the system must be managed and improved with the intention of optimising the whole system. To improve the process one must understand the process, it's aim, understand the variations within the process and then work to reduce that variation.

Understanding the process starts with flowcharting that process (Deming 1986).

Variation

Understanding variation in the system is essential to reducing it to a minimum. Deming recommended seven quality tools:

- Data collection
- Run charts
- Histograms
- Control charts
- Cause and Effect
- Pareto
- Scatter diagrams

Deming also advocated the use of just one supplier for each product to reduce costs; this is not a recommendation that is shared by his fellow authorities. He also clearly distinguishes between ‘the voice of the customer’ and ‘the voice of the process’ a distinction that is key to serving the wants and need of the customers. (Scherkenbach 1991)

Theory of knowledge

Here Deming advocates the use of Shewhart’s Plan-Do-Study-Act cycle and operational definitions to ensure clarity. Deming further refined Shewhart’s cycle into eight steps as follows:

Theory - Question - Data - Predication - Knowledge - Action - Wisdom - Theory again.

Deming wrote a great deal in this area including the need for teamwork where teams followed set down procedures, for example, the Shewhart cycle. He also claimed that management are responsible for 94 per cent of quality problems! (Deming 1993). His philosophy advocates that balance should be our aim, balance between.

- Knowledge and action
- Short-term and long-term
- Less waste more value
- Constancy of purpose and continual improvement
- Quantum leap innovation and kaisen improvement
- Individual and team
- Science and philosophy

Deming stresses the need to stay ahead of the customer, to anticipate needs and demands, for his philosophy starts and finishes with the customer.

HIS 14 POINTS FOR MANAGEMENT ARE:

1. CREATE CONSTANCY OF PURPOSE

Towards improvement of product and service.

2. ADOPT THE NEW PHILOSOPHY

We can no long live with commonly accepted levels of delays, mistakes, defective materials and defective workmanship.

3. CEASE DEPENDENCE ON MASS INSPECTION

Require, instead, statistical evidence that quality is built in.

4. END THE PRACTICE OF AWARDING BUSINESS ON THE BASIS OF PRICE TAG

Instead, minimise total cost. Move towards a single supplier for any one item, on a long-term relationship of loyalty and trust.

5. CONTINUOUSLY IMPROVE

Improve quality and productivity, and this constantly decreases costs.

6. TRAIN ON THE JOB

Institute modern methods of training on the job.

7. INSTITUTE LEADERSHIP

Adopt and institute leadership aimed at helping people to do a better job: everybody must accomplish personal transformation to adopt the principle of system.

8. DRIVE OUT FEAR

Create trust, so that everybody may work effectively for the organisation.

9. BREAK DOWN BARRIERS

Between departments and staff. People in research, design, sales and production must work as a team.

10. *ELIMINATE SLOGANS*

Eliminate the use of slogans, posters, targets and exhortations of the workforce asking for zero defects and new levels of productivity.

11. *ELIMINATE QUOTAS*

Eliminate work standards and management by objective that prescribe arbitrary quotas and numerical goals. Substitute leadership.

12. *PERMIT PRIDE OF WORKMANSHIP*

Remove barriers that rob employees of their right to pride and joy in their work.

13. *ENCOURAGE EDUCATION*

Institute a vigorous programme of education and encourage self-improvement for everyone.

14. *EVERYBODY'S COMMITMENT*

Everybody in the company will work to accomplish the transformation. The transformation is everybody's job.

A comparison of the Deming model with the EFQM model (see Table 4, page 44) shows the essential need for Leadership and to regard everything as part of a process. It also shows the need not only for People management and Satisfaction, but also for clear Policies and Strategies and Customer satisfaction processes - which, once in place, will affect all other principles. As the EFQM model shows, through the increasing effectiveness and excellence of the organisations, both impact on society and the business results will be positively affected.

THE EUROPEAN FOUNDATION FOR QUALITY MANAGEMENT		L E A D E R S H I P	P E O P L E M A N A G E M E N T	P O L I C Y A N D S T R A T E G Y	R E S O U R C E S	P R O C E S S E S	P E O P L E S A T I S F A C T I O N	C U S T O M E R S A T I S F A C T I O N	I M P A C T O N S O C I E T Y	B U S I N E S S R E S U L T S
1	CONSTANCY OF PURPOSE	/	/	/	/	/	/	/		
2	ADOPT NEW PHILOSOPHY	/	/	/	/	/	/	/		
3	CEASE INSPECTION	/	/	/	/	/				
4	PARTNER SUPPLIERS	/		/	/	/				
5	IMPROVE CONSTANTLY	/	/	/	/	/				
6	INSTITUTE TRAINING	/	/	/	/	/	/			
7	INSTITUTE LEADERSHIP	/	/	/	/	/	/			
8	DRIVE OUT FEAR	/	/			/	/			
9	BREAK DOWN BARRIERS	/	/	/		/	/	/		
10	ELIMINATE SLOGANS	/	/			/	/			
11	ELIMINATE QUOTAS	/	/		/	/	/			
12	PRIDE OF WORKMANSHIP	/	/			/	/	/		
13	INSTITUTE EDUCATION	/	/	/	/	/	/	/		
14	EVERYBODY'S COMMITMENT	/	/	/		/	/	/		
	TOTALS	14	13	10	9	14	11	6		

Table 4 - Comparison of DEMING with EFQM model

Source: Deming 1986

3.2.5 ARMAND V FEIGENBAUM

Feigenbaum championed 'total quality control' whilst at the Massachusetts Institute of Technology in 1951, much of his working life has been spent with General Electric before in 1968 founding General Systems in Massachusetts. (Brocka 1992).

His definition of quality is: Total quality means being excellence-driven, rather than defect-driven.

He believes that total quality control is the responsibility of all parts of an organisation - from top to bottom; and requires understanding by everyone.

HIS THREE STEPS TO QUALITY ARE:

1. QUALITY LEADERSHIP

A very demanding process which is thoroughly planned and specified, and constantly monitored and improved by management.

2. MODERN QUALITY TECHNOLOGY

Quality is the responsibility of everyone because traditional quality departments can only resolve 10-20 percent of problems. The goal is to achieve performances that are error-free.

3. ORGANISATIONAL COMMITMENT

Training to meet present needs is vital as is the philosophy of quality being seen as part of the strategic planning process.

Feigenbaum also set down four deadly sins and nineteen steps to quality improvement:

THE FOUR DEADLY SINS:

1. HOTHOUSE QUALITY

'Flavour of the month', in other words it is pushed hard until something else is seen as more important.

2. WISHFUL THINKING

Complacency and hoping that the problems will go away is not the answer.

3. PRODUCING OVERSEAS

This will not solve our domestic problems.

4. CONFINING QUALITY TO THE FACTORY

Quality needs to be the responsibility of everyone within the organisation.

THE NINETEEN STEPS TO QUALITY IMPROVEMENTS:

1. TOTAL QUALITY DEFINED

An effective system for integrating the quality development, quality maintenance, and quality improvement efforts of the various groups in an organisation so as to enable marketing, engineering, production, and service at the most economical levels which allow for full - customer satisfaction.

2. *QUALITY VERSUS QUALITY*

Quality does not always mean luxury, and quality standards must be continuously maintained and improved whether it is a luxury product or service or not.

3. *CONTROL*

Control has four steps as a management tool of quality:

1. Setting quality standards
2. Appraising conformance to these standards
3. Acting when the standards are exceeded
4. Planning for improvements in the standards

4. *INTEGRATION*

An organisation is one system whose aim is to ensure customer-driven quality. All facets of the organisation must be integrated to achieve this aim.

5. *QUALITY INCREASES PROFIT*

With total quality control customer satisfaction improves, losses reduce and costs decrease thus both short-term and long-term profits increase.

6. *QUALITY IS EXPECTED, NOT DESIRED*

Quality must also be expected from suppliers: once one embraces quality, others will also.

7. *HUMANS IMPACT QUALITY*

Humans will achieve the greatest quality improvements, not more machines.

8. TQM APPLIES TO ALL PRODUCTS AND SERVICES

Everyone in every department is responsible for supplying quality products and services to their customers.

9. QUALITY IS A TOTAL LIFE-CYCLE CONSIDERATION

Quality control starts with customer specification, includes all areas of the products' raw material purchase, manufacture, delivery, installation and service.

10. CONTROLLING THE PROCESS

There are four areas of control: new design control, incoming material control, product control and special process studies.

11. A TOTAL QUALITY SYSTEM MAY BE DEFINED AS

The agreed companywide and plantwide operating work structure, documented in effective, integrated technical and managerial procedures, for guiding the co-ordinated actions of the people, the machines, and the information of the company and plant in the best and most practical ways to assure customer quality satisfaction and economical costs of quality. The quality system provides integrated and continuous control to all key activities, making it truly organisationwide in scope.

12. BENEFITS

These include reduction of costs and losses, increased customer satisfaction, reduced production bottlenecks and enhanced team morale.

13. COST OF QUALITY

There are four areas to measure costs: prevention costs, appraisal costs, internal failure costs and external failure costs.

14. ORGANISE FOR QUALITY CONTROL

Quality control needs to be done and seen to be done by everyone through for example performance charts at each work station.

15. QUALITY FACILITATORS, NOT QUALITY COPS

These facilitators are for enhancing quality through communicating, training and support. They are not there as quality inspectors.

16. CONTINUOUS COMMITMENT

This is a never-ending process.

17. USE STATISTICAL TOOLS

This is a vital part of total quality control but far from the total picture.

18. AUTOMATION IS NOT A PANACEA

Focus on achieving excellence is the area of human endeavour before deciding that automation is the answer.

19. CONTROL QUALITY AT THE SOURCE

The person who produces the goods or delivers the service must have control of that product or service.

A comparison of Feigenbaum's principles with the EFQM model (see Table 5, page 50) shows that although each of Feigenbaum's principles may reflect just two of the EFQM's principles; it is the continuation of all 19 of his principles which gives an holistic strength to both his model and that of the EFQM model.

THE EUROPEAN
FOUNDATION FOR QUALITY
MANAGEMENT

		L E A D E R S H I P	P E O P L E M A N A G E M E N T	P O L I C Y A N D S T R A T E G Y	R E S O U R C E S	P R O C E S S E S	P E O P L E S A T I S F A C T I O N	C U S T O M E R S A T I S F A C T I O N	I M P A C T O N S O C I E T Y	B U S I N E S S R E S U L T S
1	DEFINE T.Q.C.	/		/						
2	DEFINE QUALITY	/		/						
3	USE QUALITY CIRCLE	/	/			/				
4	INTEGRATE THROUGHOUT	/	/	/	/	/				
5	PROFITS INCREASE	/	/		/	/	/	/		/
6	EXPECT QUALITY	/	/			/	/			
7	IMPROVE PROCESSES	/	/			/	/	/		
8	NO-ONE EXEMPT	/	/			/	/			
9	QUALITY START TO FINISH	/	/	/		/	/	/		
10	CONTROL PROCESS	/	/			/	/	/		
11	PROCESS -ORGANISATIONWIDE	/	/	/		/	/			
12	IDENTIFY BENEFITS	/	/		/	/	/	/		/
13	IDENTIFY COSTS	/	/		/	/	/	/		/
14	QUALITY IS EVERYONE'S JOB	/	/	/	/	/	/	/		
15	FACILITATORS FACILITATE	/	/	/	/	/	/			
16	COMMIT LONG-TERM	/	/	/	/					
17	USE STATISTIC TOOLS	/	/	/		/	/			
18	BE CAUTIOUS OF AUTOMATION	/	/		/	/				
19	CONTROL AT SOURCE	/	/			/	/			
	TOTALS	19	17	9	8	16	13	7		3

Table 5 - Comparison of FEIGENBAUM with EFQM model

Source: Brocka 1992

3.2.6 KAORA ISHIKAWA

Ishikawa was one of the foremost quality leaders in Japan, he was first to coin the expression 'total quality control' and to develop the seven tools of quality.

His definition of quality is: development, design, production and service of a product that is most economical, most useful and always satisfactory to the customer.

Ishikawa's quality philosophy was built upon the strong belief that education was key for all members of the organisation; he developed seven basic tools so that they could be used by everyone:

1. ***PROCESS FLOWCHARTING*** - what is done
2. ***CHECK SHEETS/TALLY CHARTS*** - how often it is done
3. ***HISTOGRAMS*** - what overall variations look like
4. ***PARETO ANALYSIS*** - which are the significant problems
5. ***CAUSE AND EFFECT ANALYSIS*** - what causes the problems and brainstorming
6. ***SCATTER DIAGRAMS*** - what are the relationships between factors
7. ***CONTROL CHARTS*** - which variations to control and how

ISHIKAWA'S QUALITY PHILOSOPHY CAN BE SUMMARISED INTO 11 AREAS:

1. *EDUCATION IS PIVOTAL*

Quality begins with education and ends with education.

2. *KNOW CUSTOMER REQUIREMENTS*

The first step in quality is to know the requirements of customers.

3. *ELIMINATE INSPECTION*

The ideal state of quality control is when inspection is no longer necessary.

4. *REMOVE THE ROOT CAUSE*

Remove the root cause and not the symptoms.

5. *ALL RESPONSIBLE*

Quality control is the responsibility of all workers and all divisions.

6. *AVOID CONFUSION*

Do not confuse the means with the objective.

7. *QUALITY FIRST*

Put quality first and set your sights on long-term profits.

8. *MARKETING IS KEY*

Marketing is the exit and entrance to quality.

9. *AVOID ANGER*

Top management must not show anger when facts are presented by subordinates.

10. *USE SEVEN TOOLS*

Ninety-five per cent of the problems in a company can be solved by the seven tools of quality control.

11. *DATA CAN BE FALACIOUS*

Data without dispersion information (variability) is false data - for example, stating an average without supplying the standard deviation.

A comparison of Ishikawa's principles with the EFQM model (see Table 6, page 54) shows, like the others, that although Customer satisfaction is essential; the organisation must get itself right as well. And that means Policies and Strategies, Processes, Resources and People Management; and from this the results will come for people satisfaction, impact on society and excellence in business results.

THE EUROPEAN
FOUNDATION FOR QUALITY
MANAGEMENT

		L E A D E R S H I P	P E O P L E M A N A G E M E N T	P O L I C Y A N D S T R A T E G Y	R E S O U R C E S	P R O C E S S E S	P E O P L E S A T I S F A C T I O N	C U S T O M E R S A T I S F A C T I O N	I M P A C T O N S O C I E T Y	B U S I N E S S R E S U L T S
1	EDUCATION IS PIVOTAL	/	/	/	/	/	/			
2	KNOW CUSTOMER REQ'MENTS	/	/	/	/	/	/	/		
3	ELININATE INSPECTION	/	/		/	/				
4	REMOVE ROOT CAUSE	/	/			/	/	/		
5	ALL RESPONSIBLE	/	/	/	/	/	/			
6	AVOID CONFUSION	/	/			/	/			
7	QUALITY FIRST	/	/	/		/				/
8	MARKETING IS KEY	/	/	/	/	/	/	/		
9	AVOID ANGER	/	/			/	/			
10	USE SEVEN TOOLS	/	/	/		/	/			
11	DATA CAN BE FALACIOUS	/	/			/	/			
	TOTALS	11	11	6	5	11	9	3		1

Table 6 - Comparison of ISHIKAWA with EFQM model

Source: Brocka 1992

3.2.7 JOSEPH M. JURAN

Like Deming, Juran is credited with part of the quality success story of Japan where he went to lecture in 1954. After being chief of the inspection control division of Western Electric and professor at New York University, he founded the Juran Institute.

Juran believes that there are two kinds of quality: 'fitness for use' and 'conformance to specification'. For example, a dangerous product could meet all specifications but not be fit for use.

'An understanding of the human situations associated with the job will go far to solve the technical problems; in fact such understanding may be a prerequisite of a solution.'

THERE ARE THREE BASIC STEPS TO PROGRESS, HE BELIEVES:

- 1. STRUCTURED ANNUAL IMPROVEMENTS COMBINED WITH DEVOTION AND A SENSE OF URGENCY***
- 2. MASSIVE TRAINING PROGRAMMES***
- 3. UPPER MANAGEMENT LEADERSHIP***

Less than twenty per cent of quality problems are due to workers, with the remainder being caused by management. Just as all managers need some training in finance, all should have training in quality in order to oversee and participate in quality improvement projects.

And top management should be included because 'all major quality problems are interdepartmental.'

He believes that one should assist poor suppliers to improve, he favours quality circles and statistical process control with the proviso that it can lead to a 'tool-oriented' approach. He states that 'there is no such thing as improvement in general. Any improvement in quality is going to come about project by project and no other way.'

When comparing the USA with Japan, he says that the USA are not as effective: 'to predict vendor adequacy US firms studied the suppliers systems - organisation, written procedures, manuals, audits and so on. The Japanese firms looked at process capabilities, process controls, acceptance of team-work relationships, extent of quality control training and quality of prior deliveries'. (Gague 1986)

JURAN'S 10 STEPS TO QUALITY IMPROVEMENT

1. BUILD AWARENESS

Build awareness of the need and opportunity for improvement.

2. SET GOALS

Set goals for improvement.

3. ORGANISE TO ACHIEVE

Organise to reach the goals (establish a quality council, identify problems, select projects, appoint team, designate facilitators).

4. PROVIDE TRAINING

5. SOLVE PROBLEMS

Carry out projects to solve problems.

6. REPORT PROGRESS

7. GIVE RECOGNITION

8. COMMUNICATE RESULTS

9. KEEP SCORE

10. MAINTAIN MOMENTUM

Maintain momentum by making annual improvement part of the regular systems and processes of the company.

A comparison of Juran's principles with the EFQM model (see Table 7, page 58) shows the strength of all the EFQM model principles: either because they have a direct bearing on Juran's principles, (for example, Leadership and People management) or they clearly have to be in place in some of these principles, (for example, Policies and Strategies and Customer satisfaction) or they are the result of the effectiveness of the 'enablers' (like Impact on Society and Business Results).

Similar to the other tables, these principles are indivisible and holistic; and only make up an 'effective whole' when all ten principles are present.

THE EUROPEAN
FOUNDATION FOR QUALITY
MANAGEMENT

		L E A D E R S H I P	P E O P L E M A N A G E M E N T	P O L I C Y A N D S T R A T E G Y	R E S O U R C E S	P R O C E S S E S	P E O P L E S A T I S F A C T I O N	C U S T O M E R S A T I S F A C T I O N	I M P A C T O N S O C I E T Y	B U S I N E S S R E S U L T S
1	BUILD AWARENESS	/	/	/		/	/			
2	SET GOALS	/	/	/	/	/				
3	ORGANISE TO ACHIEVE	/	/	/	/	/	/	/		
4	PROVIDE TRAINING	/	/	/	/	/	/			
5	SOLVE PROBLEMS	/	/		/	/	/	/		
6	REPORT PROGRESS	/	/		/	/	/	/		
7	GIVE RECOGNITION	/	/		/	/	/			
8	COMMUNICATE RESULTS	/	/		/	/	/			
9	KEEP SCORE	/	/		/	/	/	/		
10	MAINTAIN MOMENTUM	/	/	/	/	/	/	/		
	TOTALS	10	10	5	9	10	9	5		

Table 7 - Comparison of JURAN with EFQM model

Source: Brocka 1992

3.2.8 GOPAL K. KANJI/M. ASHER

Kanji & Asher emphasise that TQM is not a 'quick fix', it is a never-ending road of continuous improvement. An organisation is similar to an individual in that it needs to develop from the inside out; so top management must develop a vision, a mission, a set of values and beliefs for the organisation before it can start to service its customers. (Kanji & Asher 1993).

They strongly recommend education throughout the organisation and add that TQM is an excellent middle ground where management and academics can work together for the benefit of the organisation.

Like Taguchi, Kanji & Asher do not see organisations surviving unless they do embrace TQM: 'can we afford not to be a total quality organisation?' Kanji also goes further and says that 'a quality community relates to every aspect of life: Does a priest know what a quality sermon is? - good question!

Kanji & Asher's (1993) quality definition is: 'to satisfy agreed customer requirements.'

Kanji (1994) distilled his thinking into five governing principles four of which have two core concepts:

1. *DELIGHT THE CUSTOMER*

1.1 Customer satisfaction

1.2. Internal customers are real

2. *MANAGEMENT BY FACT*

2.1 All work is a process

2.2 Measurement

3. *PEOPLE-BASED MANAGEMENT*

3.1 Teamwork

3.2 People make quality

4. *CONTINUOUS IMPROVEMENT*

4.1 Continuous improvement cycle

4.2 Prevention

5. *LEADERSHIP*

The fifth principle Leadership, (as can be seen below) is the base upon which quality is built.

A comparison of Kanji/Asher's principles with the EFQM model (see Table 8, page 62) shows that although each of the 13 principles is very strong in its own right; the real power of Kanji/Asher's principles is the combination of all 13.

Note how much can and needs to be achieved within the organisation itself and is not wholly reliant upon outside influence - although that internal transformation must be driven through constant feedback to achieve customer satisfaction leading to people satisfaction, impact on society and excellence in business results.

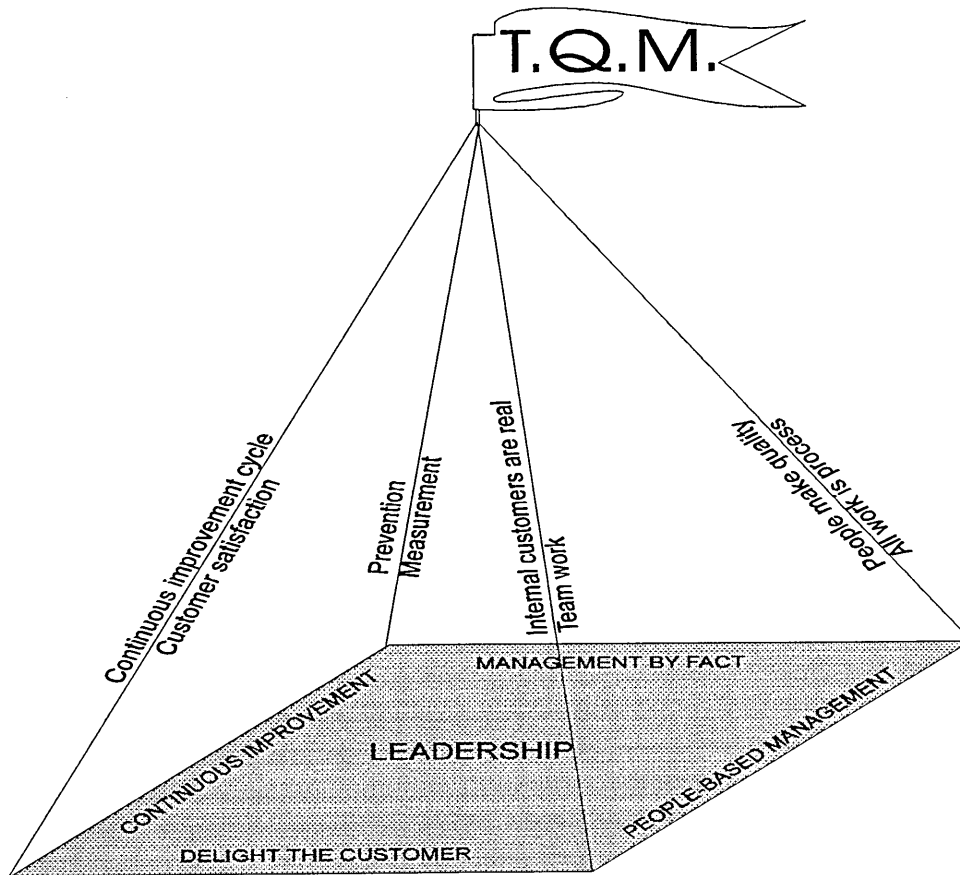

Fig. 3 - Kanji's Pyramid Principles of TQM (Kanji 1994)

THE EUROPEAN
FOUNDATION FOR QUALITY
MANAGEMENT

		L E A D E R S H I P	P E O P L E M A N A G E M E N T	P O L I C Y A N D S T R A T E G Y	R E S O U R C E S	P R O C E S S E S	P E O P L E S A T I S F A C T I O N	C U S T O M E R S A T I S F A C T I O N	I M P A C T O N S O C I E T Y	B U S I N E S S R E S U L T S
1	DELIGHT THE CUSTOMER	/	/	/	/	/	/	/		
2	MANAGEMENT BY FACT	/	/		/	/	/			
3	PEOPLE BASED MANAGEMENT	/	/	/		/	/			
4	CONTINUOUS IMPROVEMENT	/	/	/	/	/	/	/		
5	LEADERSHIP	/	/	/	/	/	/	/		
6	CUSTOMER SATISFACTION	/	/	/	/	/	/	/		
7	INT. CUSTOMERS ARE REAL	/	/	/	/	/	/			
8	ALL WORK IS A PROCESS	/	/		/	/	/	/		
9	MEASUREMENT	/	/	/	/	/	/			
10	TEAMWORK	/	/		/	/	/	/		
11	PEOPLE MAKE QUALITY	/	/			/	/	/		
12	CONTINUOUS IMPVMT CYCLE	/	/	/	/	/	/	/		
13	PREVENTION	/	/	/	/	/	/	/		
	TOTALS	13	13	9	11	13	13	9		

Table 8 - Comparison of KANJI/ASHER with EFQM model

Source: Kanji 1994

Taguchi won the first Deming prize in 1960 and since then has won it three more times. He has been one of the leaders in the quality movement throughout Japan.

His Loss Function is a powerful tool for measuring variation from target specification. It encourages continuous improvement towards the target of zero defects although he disagrees with the concept of zero defects subscribed to by Crosby because perfection is not a practical goal.

His work on the design of products is also innovatory, he believes that by working on design and production variation the 'loss to Society' will have its best opportunity to be reduced.

TAGUCHI'S QUALITY PHILOSOPHY IS ENCAPSULATED IN THESE SEVEN PRINCIPLES BELOW:

1. TOTAL LOSS GENERATED

An important dimension of the quality of a manufactured product is the total loss generated by that product to society.

2. CONTINUOUS IMPROVEMENT

In a competitive economy, continuous quality improvement and cost reduction are necessary to stay in business.

3. REDUCE PRODUCT VARIATION

The continuous quality improvement programme includes incessant reduction in the variation of product performance characteristics about their target values.

4. *USE LOSS FUNCTION*

The customer's loss due to a product performance variation is often approximately proportional to the square of the deviation of the performance characteristics from the target value. Thus, a quality measure quickly degrades with large deviation from the target. (Thus the shape of the bell in the Loss Function).

5. *FOCUS ON DESIGN AND PROCESS*

The final quality and cost of a manufactured product are determined to a large extent by the engineering designs of the product and its manufacturing process.

6. *REDUCE PERFORMANCE VARIATION*

A performance variation can be reduced by exploiting the non-linear affects of the product (or process) parameters on the performance characteristic.

7. *PLAN STATISTICAL EXPERIMENTS*

Statistically planned experiments can be used to identify the settings of product (and process) parameters that reduce performance variation.

A comparison of Taguchi's principles with the EFQM model (see Table 9, page 65), shows that even approaching the EFQM model from a very different direction, his 7 principles fit well into the model. Taguchi differs from the other authorities included in this research because he is very focused, in his 7 principles: on statistics, statistical experimentation and statistical evidence. Yet note the similarity in results and the strength of Taguchi's model.

GENICHI TAGUCHI

THE EUROPEAN FOUNDATION FOR QUALITY MANAGEMENT

		L E A D E R S H I P	P E O P L E M A N A G E M E N T	P O L I C Y A N D S T R A T E G Y	R E S O U R C E S	P R O C E S S E S	P E O P L E S A T I S F A C T I O N	C U S T O M E R S A T I S F A C T I O N	I M P A C T O N S O C I E T Y	B U S I N E S S R E S U L T S
1	TOTAL LOSS GENERATED	/	/	/	/	/	/	/		
2	CONTINUOUS IMPROVEMENT	/	/	/	/	/	/	/		
3	REDUCE PRODUCT VARIATION	/	/	/	/	/	/	/		
4	USE LOSS FUNCTION	/	/		/	/	/			
5	FOCUS ON DESIGN & PROCESS	/	/	/	/	/	/	/		/
6	REDUCE PERFORMANCE VAR'N	/	/		/	/	/	/		
7	PLAN STATISTICAL EXPERIMENTS	/	/		/	/	/			
	TOTALS	7	7	4	7	7	7	5		1

Table 9 - Comparison of TAGUCHI with EFQM model

Source: Brocka 1992

3.3 COMPARISONS

The key principles of each of the authorities set out in the previous section, have been compared - subjectively - with the nine elements of the European Quality Award (see Fig. 4, page 68). The purpose of this elaborate comparison is to help the author to develop his own model for this study.

An example of how these results have been arrived at are as follows: Is leadership essential to implement Aesop's 'Institute Teamwork'?

Yes, so the appropriate box is ticked.

In summary, Table 10, page 67 indicates that leadership, people management, processes and people satisfaction are most important issues regarding TQM. And that policies and strategies, and resources must also be in place for excellence to be seen in the areas of customer satisfaction, impact on society and business results.

Leadership is evident in every principle of each authority and is the driving force within both their models and the EFQM model.

Note also, how in every case, the authorities use their opening principles to set down policy and strategy and, although lower scoring - except for Deming, and Kanji/Asher - is clearly an integral part of every authority's model and, I feel, is a key to the effectiveness of medium size organisations.

Note: 'Customer Satisfaction' applies to external customers in this exercise. Internal customers are catered for under the heading: 'People Satisfaction.'

TQM PRINCIPLES

THE EUROPEAN
FOUNDATION
FOR QUALITY
MANAGEMENT

		P A G E N U M B E R	N U M B E R O F P R I N C I P L E S	L E A D E R S H I P	P E O P L E M A N A G E M E N T	P O L I C Y A N D S T R A T E G Y	R E S O U R C E S	P R O C E S S E S	P E O P L E S A T I S F A C T I O N	C U S T O M E R S A T I S F A C T I O N	I M P A C T O N S O C I E T Y	B U S I N E S S R E S U L T S
1	AESOP	28	6	6	6	4	1	3	6	2		
2	DEMING	42	14	14	13	10	9	14	11	6		
3	CONWAY	31	6	6	6	3	3	6	6	3		
4	CROSBY	35	14	14	14	2	13	13	10	2		
5	FEIGENBAUM	48	19	19	17	9	8	16	13	7		3
6	ISHIKAWA	52	11	11	11	6	5	11	0	3		1
7	JURAN	56	10	10	10	5	9	10	9	5		
8	KANJI & ASHER	60	13	13	13	9	11	13	13	9		1
9	TAGUCHI	63	7	7	7	4	7	7	7	5		1
	TOTALS	-	100	100	97	52	66	93	84	42	0	6

Table 10 - Comparison of TQM principles with EFQM model

THE EFQM MODEL

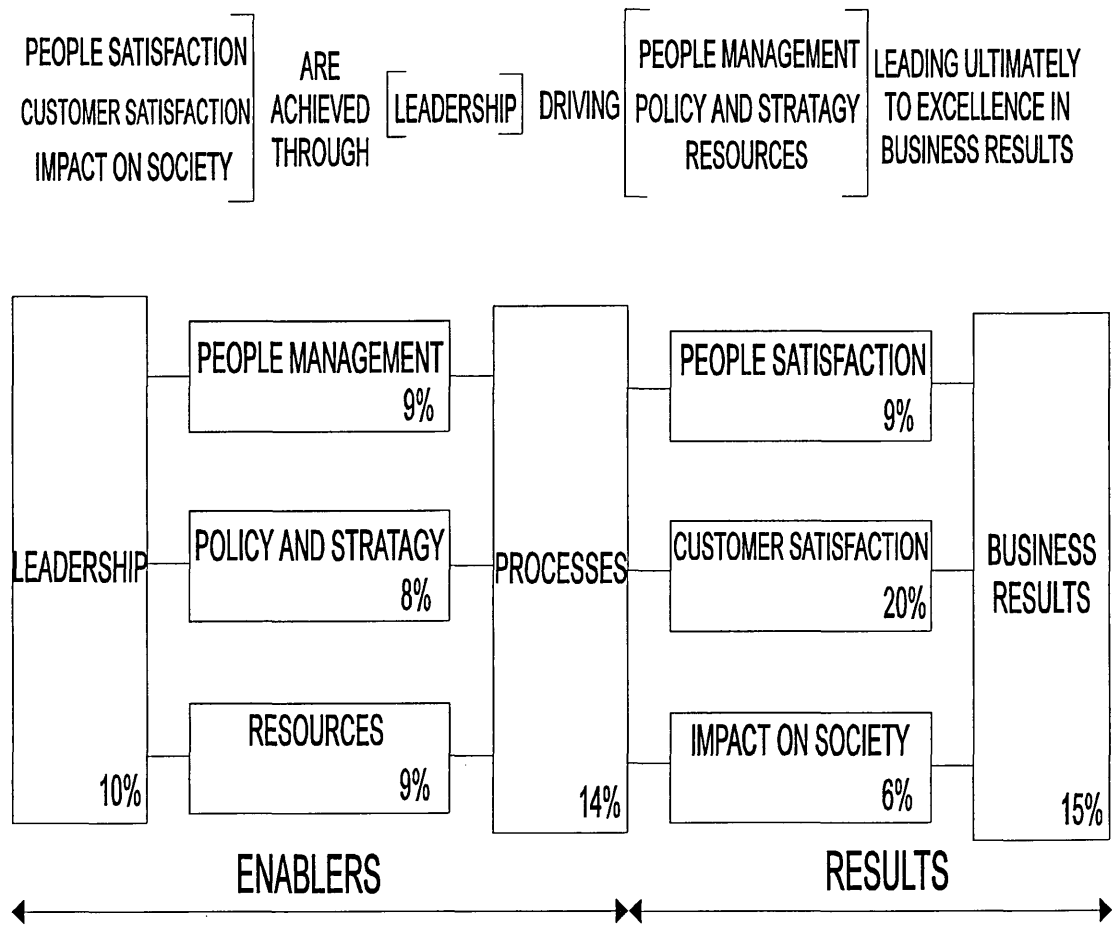

Fig. 4 - The EFQM Model

3.3.1 LEARNING POINTS FROM COMPARISON EXERCISE

- Leadership is the essential ingredient behind all the quality principles.
- Many of the quality principles can be implemented within the organisation without prior reference to outside customer.
- If the principles are going to be effective, processes must be put in place to ensure implementation, consistency, that they are measured to obtain the facts and that the processes are continuously improved.
- The whole team must be involved once the policy decision for implementation has been taken.
- TQM is process not outcome orientated, thus although there is little mention of 'Impact on Society' or Business Results, which are not principles; both elements benefit greatly by the 'enablers' being effective. Incidentally, Deming's philosophy is being used within the community with great effect by Myron Tribus in the City of Erie, also in Wilmington and Edina schools (Tribus 1994).
- Each principle is interdependent upon every other principle.

3.4 PRINCIPLES OF TQM

Introduction

Following the research carried out on the authorities in Chapter 3.2 and lessons learned in Section 3.3.3; I have now adopted the following five principles. They are set out in Figure 5, page 71 as a star to show both their interdependence and their simplicity.

The model incorporates all the facets of the EQA, the comparison set out in Figure 6 has the following logic behind it:

- **Leadership** is the driving force within an organisation and therefore is at the top of my interdependent star. A major part of the leader's job is to give direction and create the culture within which to work, therefore policy and strategy are also included here.
- **Continuous improvement** is the force that underpins the whole process. It is the constant reminder of Shewhart's quality circle, the feedback loop of plan - do - study - act.
- **Loyal Customers** covers external customers in the EQA model. However it can also cover internal and external customers, thus all stakeholders: employees (people satisfaction), customers (customer satisfaction), suppliers, shareholders and the community (impact on society).
- **Management by fact** incorporates both resources and processes.

- **Teamwork** covers people management and satisfaction.

With just these five TQM principles in the star model, all the key areas of a world class organisation are to be found. This gives a simple and easy-to-remember model

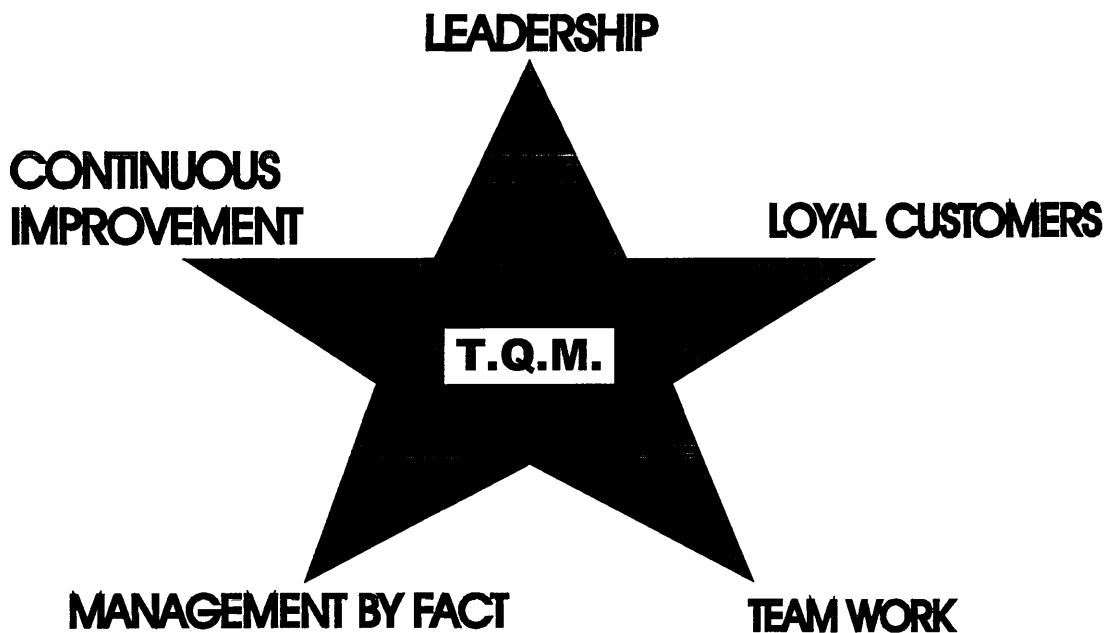

Fig. 5 - Interdependence between the five TQM principles

Another way of showing the same information and comparing it with Fig. 4, page 68, is as follows:

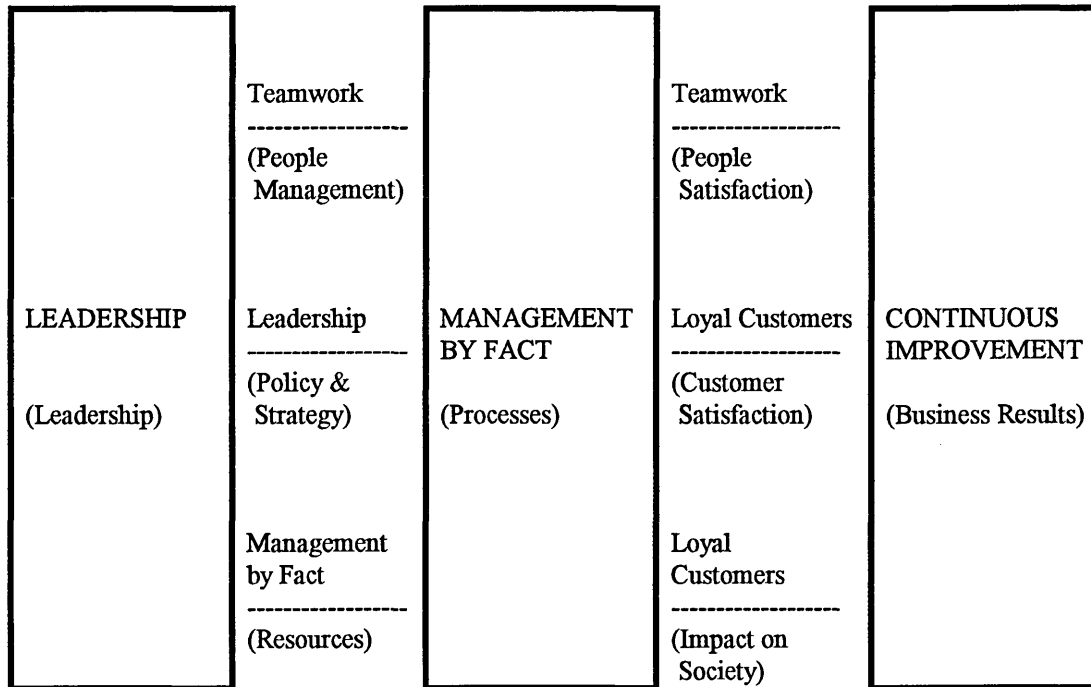

Fig. 6 - Graphical comparison of the author's TOM principles with the EFQM model

Each principle will be set out now in more detail to show its importance and its interrelationship - and interdependence - with the other four principles. They are set out in the following order:

3.4.1 LEADERSHIP

3.4.2 LOYAL CUSTOMERS

3.4.3 TEAMWORK

3.4.4 MANAGEMENT BY FACT

3.4.5 CONTINUOUS IMPROVEMENT

3.4.1 LEADERSHIP

‘The aim of leadership should be to improve the performance of man and machine, to improve quality, to increase output and simultaneously to bring joy of workmanship to people.’ (Deming 1993)

‘Managers do things right and leaders do the right things’ - Peter Drucker and Warren Bennis.

‘A manager can climb life’s ladder most efficiently but its not much use if the ladder is leaning up against the wrong wall! Selection of the right wall or direction is the art of being effective and that is the leader’s job’ (Covey 1989)

David B Luther, Vice President and Director of Quality for Corning Inc (World-wide), said in a speech I attended in Washington in December 1992: “Organisations are changing fast and their future can be summed up as follows:

1. Quality must be ‘perfect’ - this will be the customers’ minimum requirement!
2. Organisations will be shaped to fit its aim; processes not functions; teams not managers; and leadership meaning coaching, facilitating and motivating.
3. There will be more ‘quality’ organisations.
4. Life will get tougher and faster so continuous improvement is essential.”

I agree with all four of these points: the third and fourth are self-explanatory, the first is dealt with under ‘Loyal Customers;’ the second point will be dealt with here using Leadership and Policy & Strategy:

The following model applies just as much to an organisation as it does to an individual, and is based upon the premise that before one can become a coach (leader) and teach anyone anything, there are two prerequisites: (Covey 1989)

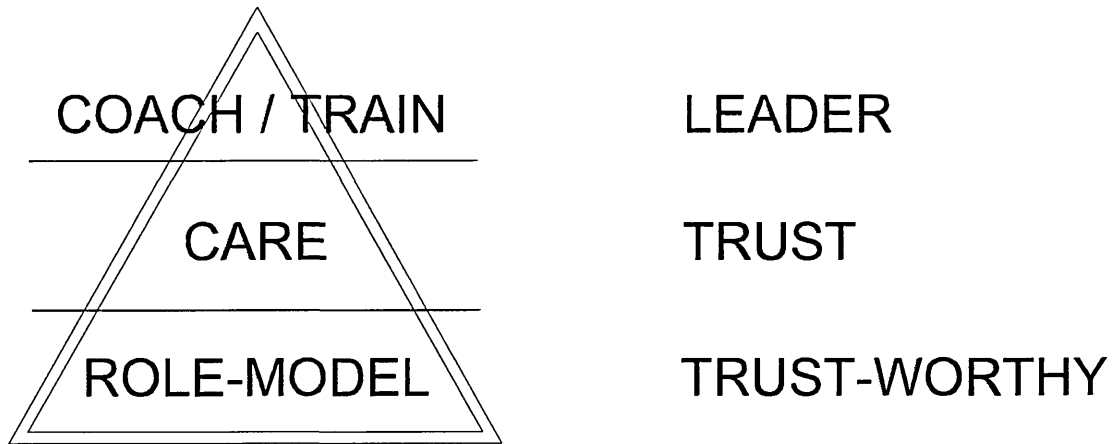

Fig. 7 - The Leadership Triangle

First, one must become a role-model; in that way one becomes 'trust-worthy.' But that is not enough, one must also 'care' and by being a role-model and by caring one becomes trusted.

Then, one becomes worthy of being listened to: a coach, a leader.

So what is a 'Role Model'?

A role model has four facets:

A. Purpose - Direction

B Integrity - Values

C Competence- Education

*D Maturity - Courage
- Consideration*

A. Purpose

'A system without an aim, isn't a system' (Deming 1986).

'Give me a firm place to stand and I will move the earth' (Archimedes)

One of the causes of variation is because the individuals within a team are not clearly aware of what the purpose of their team is - what it is aiming to achieve.

A clear Vision or Mission Statement, regularly communicated, discussed and reviewed is critical to gain ownership by the team. Each process within that organisation must also have a clear aim.

To have 'balance' - reduced variation - one needs a fixed point on which to focus upon.

A metaphor: a boat, out at sea, needs to know what harbour it is making for - in fact, it is essential that all of the crew are aware of that aim. Without it, the boat can be taken in any direction and achieve nothing; if it is clear where they are going, adjustments can bring them back on course after being diverted by the winds and currents of change.

B. Integrity

Integrity means: 'walking the talk'; having a set of values and living them.

The values of Philips, the international electrical giant are; Truth, Accountability, Support, Trust and Excitement.

The values of Mars Inc. are; Quality, Responsibility, Mutuality, Efficiency and Freedom (Mars 1993).

My personal ones are; Absolute Honesty, Purity, Selflessness and love - each day one can strive to improve - and learn from the lessons having failed during the previous day!

An organisation needs values, as does a team, and as does an individual.

Why? Because in this rapidly changing world one needs a touchstone, or a compass, upon which to rely when making decisions. For example; Richard Wells, upon his arrival in his new post as Chief Constable of South Yorkshire Police, sent out a letter to all of his officers. In it he said:

'If your actions are lawful, reasonable and honest, you will not be punished for errors or omissions'.

Officers are now clear upon where they stand and can 'walk the talk'

C Competence

‘Quality begins with education and ends with education’ (Ishakawa’s first principle)

‘Train on the job; Institute modern methods of training on the job’
(Deming’s 6th principle)

‘Encourage Education; Institute a vigorous programme of education and encourage self improvement for everyone’ (Deming’s 13th principle)

It is not enough to have a clear purpose and integrity, one has got to have the competence to achieve the purpose

The education required can be split into two categories; One is to gain the skills needed to do the specific job required to be done. The second is to improve that process. ‘The worker’s job is to work in the process, the manager’s (leader’s) job is to work on the process’ - Deming.

‘Without facts - gathered by the use of TQM tools - management ‘tampers with the system’ to achieve ‘quick fixes’.’ - Deming

A story; At Christmas, I was telling Paul Thompson, who practices Tai Chi with me on Saturday mornings, that I was finding it hard to produce my annual plan for 1995 - something I have done religiously for the past perhaps ten years. ‘Who is your role-model, Richard?’ ‘Ultimately, Christ’ ‘Did he have a five year plan, or did he just prepare - to be ready for whatever was in store for him?’ I didn’t write a business plan, although I did clarify those areas in which to prepare - to continuously improve.

D. *Maturity*

Maturity is the understanding of the interaction between courage - need to achieve one's aim or task - and consideration - for others in that process.

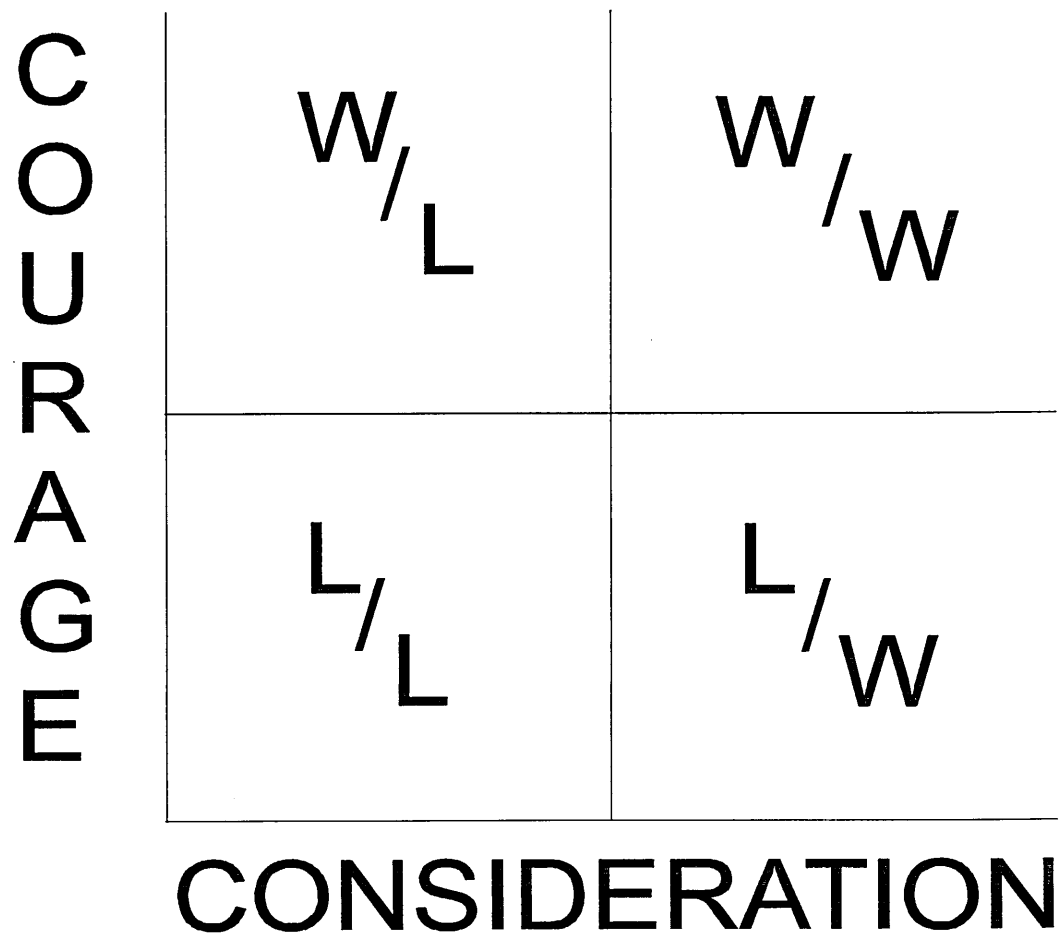

W = Win

L = Lose

Fig. 8 - The Maturity Model (Covey 1989)

This model shows the effects of one's behaviours:

- If I lack courage, to achieve my task, and have little or no consideration for others; we have a lose/lose situation: I lose and so does everyone else.
- If I have great courage and determination to achieve my task but no consideration for others; then we have a win/lose situation: I win and others lose. This is only a short-term win for me, because in the long-term relationship, I lose too.
- If I have little courage but lots of consideration for others; then it is a lose/win situation. I lose and others win - in the short-term. In a long-term relationship we all lose.
- If I have great courage and consideration for others; then we have a win/win situation: we all win.
- There is one more 'level': if I have great courage and consideration for others, yet we cannot come to an agreement - which often happens where perhaps your aims are different to mine - then we have a 'win/win or walk away' situation (Carlisle 1989). This means that although we may not agree, on this specific occasion, we 'trust' each other and have formed a long-term relationship - so that next time we start at the level of win/win.

'Courage' in this model is actually 'moral courage' which means an aim to be achieved through a process based upon one's values.

So what does it mean to 'care'? (see Fig. 7, page 75)

As stated in the introduction, these five principles are integrated and intertwined with each other. 'Caring' is dealt with in depth under

‘Teamwork’ below, although because it is so fundamental it could have been included under any of the five principles.

3.4.2 LOYAL CUSTOMERS

A. Clarify Needs

B. Relationships

C. Feedback Loop

‘The first step in quality is to know the requirements of customers’ - Ishakawa’s second principle.

‘Delight the customers’ - Kanji & Asher’s first principle.

‘Close to customers’ - Tom Peters’ third principle.

As can be seen from Fig. 2 on page 39 the aim of the processes within an organisation is to fulfil its customers needs.

A. Clarify Needs

To do this, one must put systems in place to; ascertain customer needs and agree standards; plan to achieve these needs; decide upon measures needed; train to achieve these standards; produce and measure the products or services; and, finally, analyse, evaluate and improve upon the process.

The more one works with the customer, in each of these areas, the more probable it is that the customers’ needs will be met.

The model below sets out the process - it is used within Royal Mail and the steps can also be seen in Rank Xerox's winning EFQM submission (Rank Xerox 1992)

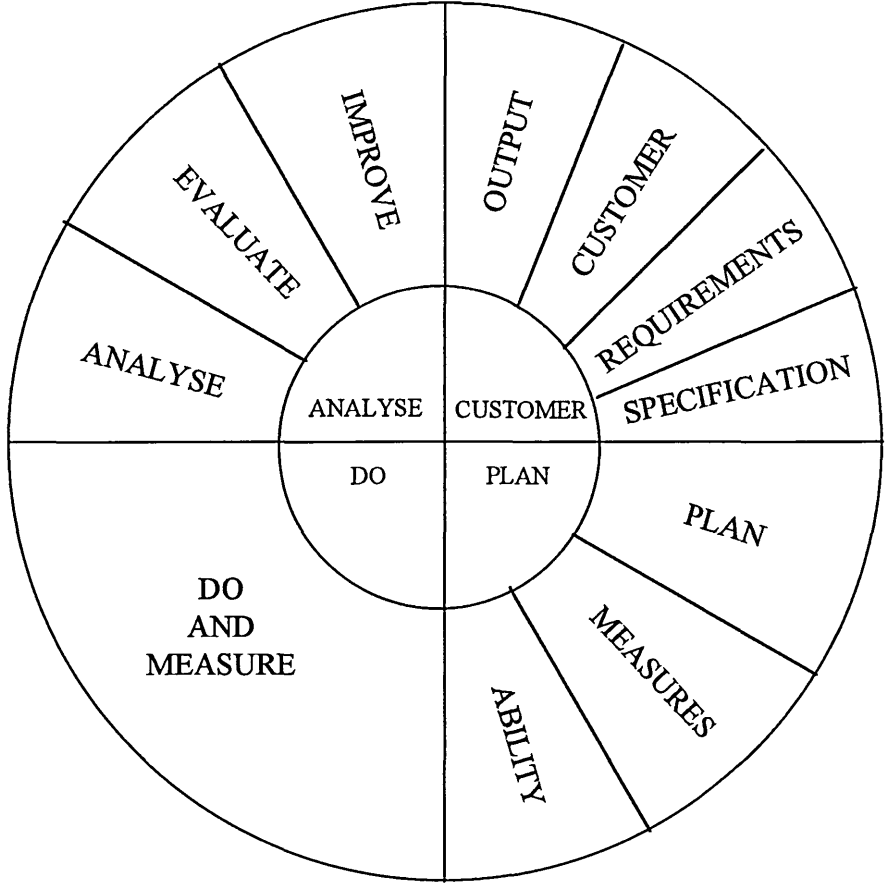

Fig. 9 - The Quality Circle

B. Relationships

The model can be used just as effectively between internal customers too. I have found that by setting down on paper the needs of a team member, and their needs of me - and both signing it and sticking it up on the wall for us to refer to - one has a point of reference, a set of standards to adhere to.

Why not 'Delighted Customers'?

Customers are 'family' and should be treated with the same respect and honesty. One's spouse cannot always be 'delighted' although one strives for 'loyalty'.

A 'loyal' customer is one that works with you in spite of one not being perfect - because we have a long-term relationship. Inevitably, something will go wrong; however, there must be a deep enough trust - see Leadership above - that together the difficulties can be overcome, for the sake of our long-term relationship.

Why not 'Loyal Stakeholders'?

Business is 'holistic' and therefore, just like an individual, one cannot be successful - long-term - in one area and unsuccessful in another. The following is a quote from the 'Principles for Business' produced by the Caux Round Table, a group of Japan's, America's and Europe's largest companies' chief executives:

'The value of a business to society is the wealth and employment it creates and the marketable products and services it provides to consumers at a reasonable price commensurate with quality. To create such value, a business must maintain its own economic health and viability, but survival is not a sufficient goal.' (Now here comes the key part)

'Businesses have a role to play in improving the lives of their customers, employees and shareholders by sharing with them the wealth they have

created. Suppliers and competitors as well should expect businesses to honour their obligations in a spirit of honesty and fairness. As responsible citizens of the local, regional, national and global communities in which they operate, businesses share a part in shaping the future of those communities.'

However, one cannot be 'all things to all people' without losing one's focus, and focus is pivotal to a successful organisation. (Taguchi 1980).

C. Feedback Loop

The Shewhart or Deming cycle, below, shows the key stages in the process that is required between customers and suppliers throughout the organisation's process (Scherkenbach 1991)

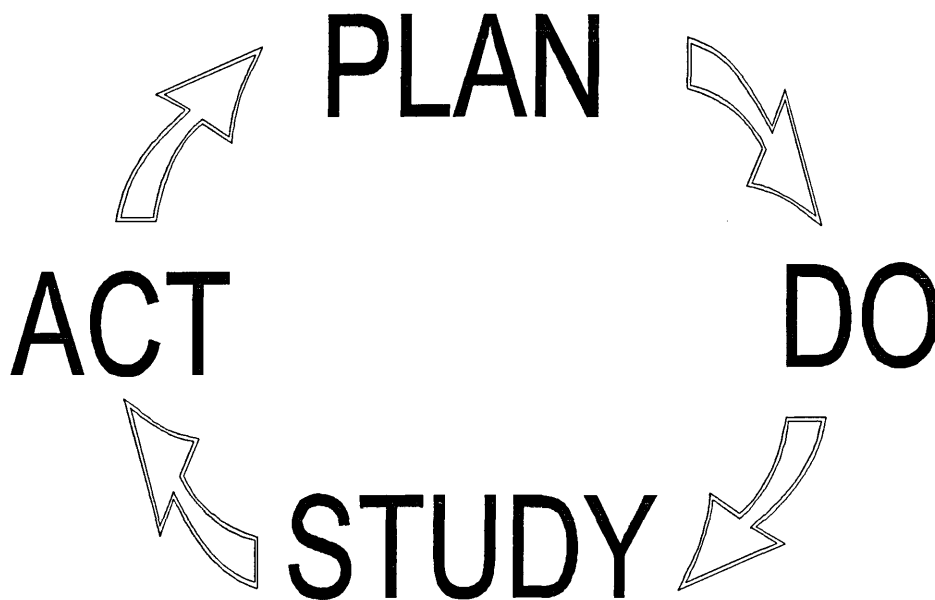

Fig. 10 - The Shewhart or Deming Cycle

So, Deming's process model (see Fig. 2, page 39) in reality works like the following - a series of Shewhart cycles:

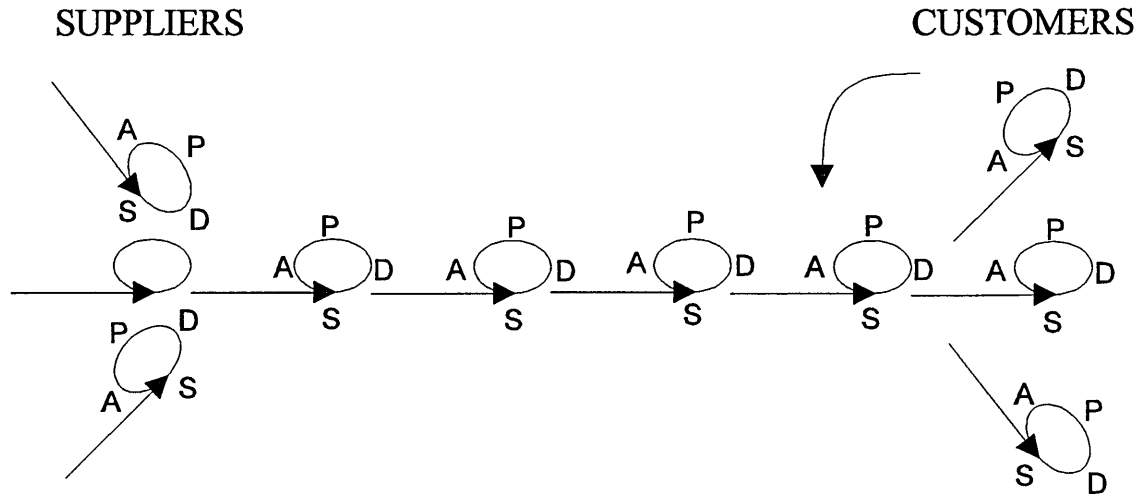

Fig. 11 - Combination of Fig. 2 and Fig. 9

Just one final point, an organisation - in reality - has more than one key process: usually between five and nine - Rover has eight. Holiday Inn has eight.

Also, management needs to work on the processes:

‘Establish a committee for the zero defects programme’ and ‘Establish quality councils to communicate on a regular basis’ - Crosby’s seventh and thirteenth principles.

So a ‘role-model’ organisation is a set of regular, disciplined feedback loops continuously striving for improvement.

3.4.3 TEAMWORK

A. Trust

B. Communication

‘Human Relations Skills’ - Conway’s first principle.

‘Form quality improvement teams’, ‘Raise Awareness’, ‘Establish Committee’, ‘Communicate obstacles’ and ‘Establish Councils’ - Teamwork is included in five of Crosby’s principles.

Communication and teamwork are central cores throughout all the ‘authorities’ principles. For if an organisation has more than one person, the only way to become an effective organisation is through teamwork.



Fig. 12 - Spheres of Influence

A person can influence a team, and a team can influence an organisation, but by themselves an individual cannot influence - as a general rule and in the long-term - an organisation. Teamwork comes through:

- Recognising each other as leaders (see Fig.7, page 75) and understanding that everyone is our coach and teacher if only we become aware of that fact.
- Setting down simple, clear, disciplined processes for communication.



Fig. 13 - Organisation Tree

Trust comes through respect for our colleagues - see Leadership above - they are the 'roots' of an organisation; with communication the organisation becomes strong and grows, the sap feeding the whole tree; with strong trust and communication; the healthy results appear, with strong roots and sap the healthy fruits appear!

A. Trust

Trust is the result of - as we've seen in Leadership above - being a 'role-model' and caring: to be an effective team - a 'role-model team' we must share the same clear purpose, share the same values, be continuously learning and gaining competence, and striving with courage towards our purpose/aim with consideration for others.

Not only should an organisation have a clear purpose and values, but so should each team - produced, agreed and regularly reviewed by the whole of that team; as each process within a system has its own aim.

The 'Cranfield model' shows how vital it is for an organisation or team to share values with each individual - to ensure both the team and each individual are pulling in the same direction.

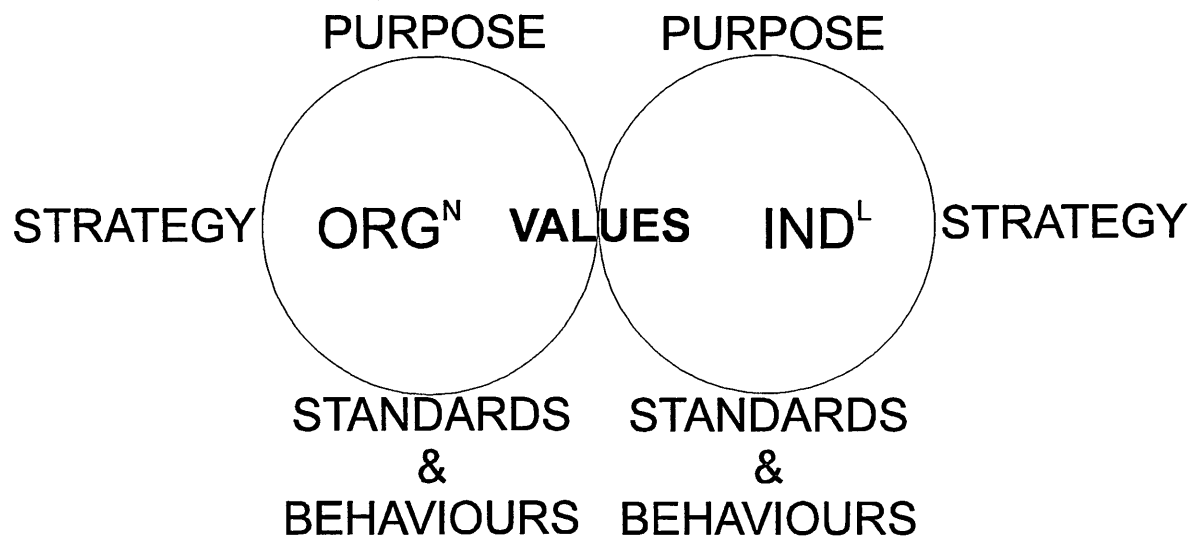

Fig 14 - A Sense of Mission comes from a Values Match
(Adapted from Campbell 1990)

To illustrate this another way. John Adair's Action-Centred Leadership model clearly shows that there are three key areas to focus upon: Achieving the aim, whilst building a team and developing the individuals within that team. The more that these are accomplished, the more the three circles overlap and the more effective the team becomes.

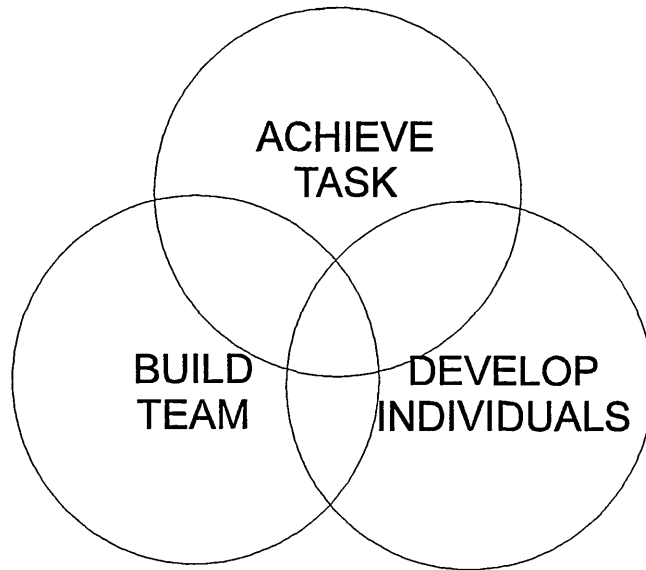

Fig. 15 - What a Leader has to do (Adair 1983)

So, referring back to the leadership model (see Fig.7, page 75) by being a 'role-model' one becomes 'trust-worthy'. But to become trusted one must also 'care'; how does one 'care' for a colleague? For caring is more than just respect, it is a type of love; and how does one 'love' someone at the same time as having to be critical about their decisions and behaviours - in other words, how can one be both courageous and considerate at the same time?

By listening, by listening to the individual - the customer - and understanding - really understanding - their needs one will do two things:

- grow to respect and care for the person
- understand clearly their needs and by understanding their needs one can put one's own needs forward from their perspective, rather than one's own.

So how can one correct another in a caring way?

By separating the individual from the issue. Thus, if a behaviour is below standard: 'I know that you are competent in this job and therefore the 'below standard' work just completed is not something that I would expect from you. What are your thoughts upon this and what action should we take to ensure that this does not reoccur?'

B. Communication

There are a few simple, clear, disciplined processes needed: What is needed is a regular, built-in feedback loop for each process. The more the team members are involved in decision-taking the more motivated they will feel. However, it is not possible in a medium-size organisation to include everyone in every decision so clearly understood communication processes are essential:

- After the organisation's purpose and values have been agreed, involving as many of the team as is practical, it should be clearly and regularly communicated and reviewed. Each team needs also to produce their own purpose and values
- Regular, no less often than monthly, top team meetings should be held and, immediately afterwards, a process of briefing all the teams within the organisation is required to communicate meeting's outcomes.

The Industrial Society's briefing system is ideal:

	ORG ^N INFO	TEAM INFO
POLICY	A TQM training programme is being implemented which will include everyone in the Company	We will commence three-shift working from this weekend - due to our increased order load
PROGRESS	Our turnover for last month was £5.4 million, an increase of 20 per cent over last year	This week we produced 400 tonnes of product - another record, and all orders were delivered on time!
PEOPLE	Bob Smith, senior fork lift truck driver retires at the end of this month - after 35 years service	There will be a leaving party for Bob Smith - all invited - in the dining room at 7.30pm on 31 st
POINTS FOR ACTION	Please ensure new Health & Safety rules (No A12234) are implemented by the end of this month	Geoff Jones & Nigel Fox will be away for all next week, to attend a training course in TQM tools and techniques

Fig. 16 - A Briefing sheet

Team meetings need to be held more often, if practical: Nissan teams meet every morning and cover just four points, which I ascertained on my visit there in 1994:

- What were the results of yesterday's work?
- What were the barriers that stopped us doing even better?
- What action will be taken and by whom to overcome these barriers?
- What are our targets for today?

Another powerful briefing process is as follows:

- These are the facts that I can tell you.
- These are the facts that I can't tell you.
- These are the areas where I don't yet know the facts, but when I do, I'll either tell you or tell you that I can't tell you!

The key to effective communication is the feedback loop - all briefings must have the facility to feed back information as well as receive it.

3.4.4 MANAGEMENT BY FACT

A. Processes

B. Variation

C. Priorities

D. Feedback

E. Problem Solving

Gather data - internal and external, 'simple statistical techniques'

Statistical process control - Conway's second, third and fourth principle.

Measure problems - Crosby's third principle.

To understand variation use the seven quality tools - Deming's profound knowledge.

Use the seven tools - Ishiwaka's tenth principle.

Keep score - Juran's ninth principle.

Management by fact - Kanji's second principle.

Plan statistical experiments - Taguchi's seventh principle.

A Processes

TQM advocates very few tools to work with and they are all simple, or relatively simple to use - see page 40 for the seven quality tools. To these have been added a further seven 'management and planning tools':

- Affinity Diagram
- Interrelationship Diagram
- Systematic Diagram
- Glyph
- Matrix

- Arrow Diagram
- Programme Decision Process Chart

For further understanding of Total Quality methods, see Kanji & Asher (1996)

Shewhart Cycle (Fig. 10, page 84)

What matters is not so much the tool that one uses but the use to which one puts it; for example, the Shewhart Cycle is used on the shop floor in Nissan where it is posted up on the notice board, below is shown a made-up poster similar to one at Nissan:

Team A - Meeting

Plan	- 15 mins	- How can tray 23 be more effectively designed?
Do	- 10 mins	- Make prototype
Study	- 10 mins	- Learn from process
Act	- 5 mins	- Decide on process to implement and action
Total	45 mins	

This same cycle is used to learn how to Juggle! (Finnigan 1993).

Flowcharting

The first tool to put in place is that of a flow chart: to put down on paper - and preferably display on the wall for all the team to see - the key processes used by the team (Scholtes 1988).

Dependent upon whether the process is being set down for the organisation, department or individual would affect the detail of the flow chart: ‘ten thousand feet, one thousand feet and one hundred feet above the process’

Here is a simple flowchart used by my P.A. Jenny Parkin, and myself to decide whether or not to accept a speaking engagement:

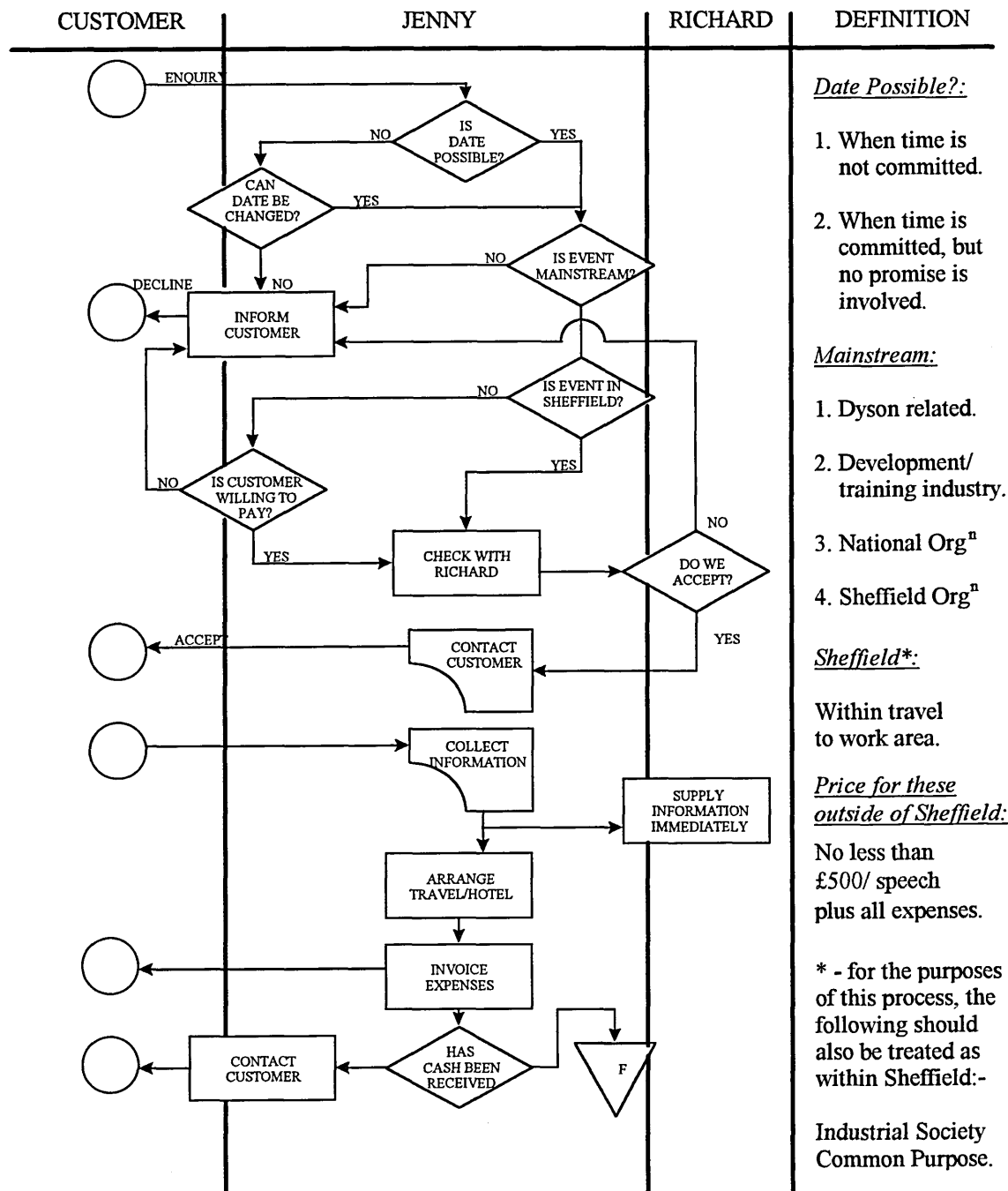

Fig. 17 - Speaking Engagement decision-making flow chart

B Variation

Once processes have been set down using, say, flowcharting and the Shewhart cycle; then monitoring can be achieved through using run charts, histograms, control charts, and/or scatter diagrams. These will set down the facts and identify variation, and through the use of process control charts will separate common causes from special causes. It is the special causes which require work on them by management.

C Priorities

Pareto charts, or even pictures - for example, making the outline of a body marking which part of the body had been injured each time an accident takes place in the factory - clearly identify where the most urgent and important action needs to be taken.

In problem-solving, the Ishikawa diagram (also called the fishbone and cause and effect diagram) is a simple and effective way of brainstorming and prioritising. Komatsu (UK) had a board at each workstation when I visited their factory in 1993. The key issues were already filled in with, I believe: men, money, machines, materials and method

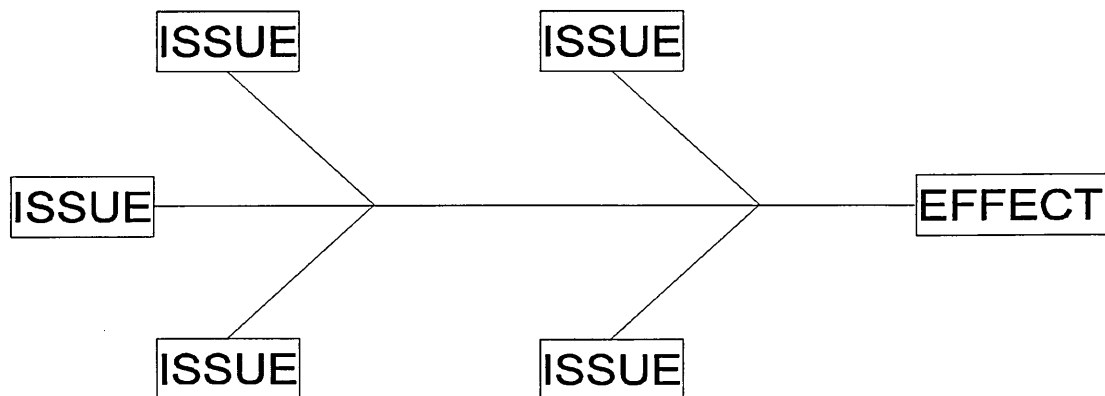

Fig. 18 - Ishikawa Diagram

After brainstorming under each issue, it is a simple task to decide which is the most urgent and important cause to start with; then to produce an action plan of who is going to do what and by when to overcome that barrier/cause. I find this process most effective for working with a team to clarify all the areas to be addressed (causes/issues) in the process of becoming a 'world class team' (effect). This powerful process can be used for an individual, a team and for an organisation.

D Feedback

The key to management by fact is to ensure that not only are measures identified and implemented on key processes; but also that the results are analysed, evaluated - from which lesson are learned - and action is taken to further enhance (continuously improve) this process.

E Problem Solving

It is interesting to note the effect that management commitment and quality tools can make. Here are some of the 'authorities'' comments:

<u>Page</u>		<u>Percentage of Company problems Solved</u>	<u>By using</u>
29	Conway	85	Seven tools (In less than a year you ought to be able to perform miracles)
32	Crosby	40 50	Committed workforce Clearly stating customer requirements
36	Deming	94	Management's responsibility
43	Feigenbaum	80-90	Other people besides the traditional quality departments
49	Ishikawa	95	Seven tools
53	Juran	80	Management's causes

3.4.5 CONTINUOUS IMPROVEMENT

A Circles

B Lessons Learned

'Improve constantly' - Deming's fifth principle

'Improve processes' - Feigenbann's seventh principle

'Continuous Improvement - Kanji's fourth principle and Taguchi's second principle

'Never cease from exploration. And at the end of all your exploring you will arrive at the place where you started and see the place for the first time' - T.S. Elliot

A Circles

Every area in an organisation can be improved, and with the tools set out in 'management by fact' above and using the feedback - and learning from it - the organisation will be continuously enhanced.

The key idea to understand here is that improvement can be: in great leaps, incremental steps or a combination of the two; but the improvement - in whatever form, must be continuous and never-ending - this is the great challenge and excitement!

A simple technique is to use a flip chart at the end of every meeting as shown in Fig. 19, page 99.

What went well?	What could be done better?	What action will be taken, by whom and by when to ensure that it will be done even better next time?

Fig. 19 - Review Tool

B Lessons Learned

In every feedback loop, time is needed to reflect upon the results and understand the lessons learned so that processes can be enhanced, process records updated and actions can be taken.

CREATION OF THE QUESTIONNAIRE

4.1 AREAS ADDRESSED

As stated in 1.2, one of the purposes for this research is aimed at identifying the key principles and actions which a leader and his/her team of a medium-size organisation might take, which would create an excellent business with an enhanced probability of survival and growth in this rapidly accelerating world of change.

Having identified the key principles in chapter three, they are now used in the area of Leadership, along with Policy and Strategy - to identify if these principles are being used and to what effect within the organisations researched.

Like the EFQM model the star model is designed so that customer satisfaction, people employee satisfaction and impact on society are achieved through leadership driving policy and strategy, people management and resources and processes leading ultimately to excellence in business results.

Leadership is the driving force within an organisation, and as explained in 3.4.1, should be intrinsic not only to the organisation but to everyone within the organisation.

Policy and Strategy are the backcloths to the workings of the organisation, and by comparing the perceptions of each chief executive and his staff, the effectiveness of the organisation should be highlighted.

Addressing these two areas actually uncovers fundamental points from every area of the EFQM and star models - as one would expect.

4.2 STRUCTURE OF INTERVIEWS

To find out what the chief executives' perceptions of how their organisations were run, and also how their teams thought their organisations were run the following process was used: Where percentages have been used the interviewees were asked to draw a cross on a line from 0 to 100 - this was then bracketed into blocks of percentages (see for example Table 15, page 112); it was important to interview, without fear of retaliation for any adverse comments, the chief executives and a random sample of team members.

So upon arriving at each TEC and commencing the chief executive interview; the chief executive would, on request, produce an organisation chart and I would select the following who were asked to stand by to be interviewed:

- one top team manager
- one middle manager
- one junior team member

At the 'team member' interview I would commence by giving my word that their comments would be kept anonymous if and when included in this report.

Within one day of the interview I wrote to each interviewee - including the chief executive - thanking them for their time and help and pointing out one of their greatest strengths. They all had many of course.

The questionnaires are set out below:

Questionnaire - Chief Executives

	<i>Page</i>
<i>CE1 Do the following reflect the four other principles of continuous improvement, loyal customers, management by fact and teamwork:</i>	<i>102/103</i>
<ul style="list-style-type: none">• <i>Vision</i>• <i>Mission Statement</i>• <i>Strategic Objectives</i>• <i>Values - and what are they?</i>	<i>106/107</i>
<i>CE2 How does your policy and strategy reflect feedback from/about:</i>	
<ul style="list-style-type: none">• <i>Staff and internal teams</i>• <i>Customers - and who are they?</i>• <i>Suppliers - and who are they?</i>• <i>Other organisations including TECs (through teamwork)</i>	<i>110-112</i> <i>114</i> <i>115</i> <i>129</i>
<i>CE3 How do you communicate your policy and strategy to your staff?</i>	<i>113</i>
<i>How do you evaluate and improve the effectiveness of communication?</i>	<i>120</i>

CE4	<i>How do you ensure that your policy and strategy is reflected in the business plan?</i>	122
CE5	<i>How do you ensure that your policy and strategy is regularly evaluated for it's effectiveness and relevance?</i>	124
CE6	<i>How do you link your policy and strategy with your drive for excellence in the service you provide?</i>	126
CE7	<i>Do your managers use total quality methods to communicate and involve their teams?</i>	125
CE8	<i>How do managers ascertain awareness of total quality within your TEC?</i>	125
CE9	<i>What methods do you use to motivate your people:</i>	118/119
	<ul style="list-style-type: none"> <i>• Salary increases</i> <i>• Job rotation</i> <i>• Management by walking about</i> <i>• Quality improvement teams</i> <i>• Awards</i> <i>• Other</i> 	
CE10	<i>How effective do you believe your organisation's policy and strategy is?</i>	108

Purpose of Questionnaire: To understand how the executive team and all other managers inspire and drive total quality as the organisation's fundamental process for continuous improvement

Questionnaire - Team

	<i>Page</i>
<i>T1</i> <i>What is your organisation's:</i>	<i>102/104</i>
• <i>Vision</i>	
• <i>Mission Statement</i>	
• <i>Strategic Objectives</i>	
• <i>Values</i>	<i>106/107</i>
<i>T2</i> <i>What ownership do you feel for the policies and strategies of your organisation?</i>	<i>109/110</i>
<i>T3</i> <i>How much do you feel appreciated by your management?</i>	<i>117</i>
<i>T4</i> <i>What motivates you?</i>	<i>118/119</i>
<i>T5</i> <i>How could your organisation be even better?</i>	<i>121</i>
<i>T6</i> <i>Whilst with the organisation, have you participated in:</i>	<i>127</i>
• <i>Formal training</i>	
• <i>Leadership training</i>	
• <i>Communication or teambuilding training</i>	

Purpose of Questionnaire: To understand if the team feel and are included in the operations of the organisation.

CHAPTER FIVE: RESULTS OF INTERVIEWS

5.1 INTRODUCTION

The results of the forty interviews are set out below using the five TQM principles of the star model identified in Chapter three. Samples of tables used in the interviews are attached in Appendix B, page ???. They are set out in such a way that a comparison can be done between the perceptions of chief executives and team members.

Findings and recommendations from these comparisons are set out in Chapter Six.

5.2 LEADERSHIP

‘Create constancy of purpose’ - Deming’s first principle

In the leadership triangle - Fig. 7, page 75 - a role-model needs purpose and integrity - defined as ‘walking the talk’ or living one’s values. So the questions asked sought to establish both chief executives’ and teams’ perceptions:

1. Did the Vision, Mission, Strategy objectives and Values reflect the four other principles of continuous improvement, loyal customers, management by fact and teamwork? (see Fig.20, page 106) - CE1 page 102.
2. Did the team know what the Vision, Mission, Strategic Objectives and Values of their organisation were? (see Fig.21, page 107)- T1 page 104.

Table 11 - Number of TQM Principles included - CE1 page 102

No. Of Org'n	Number Of TQM Principles					Total No Of Org'n
	None	One	Two	Three	Four	
Vision	8	0	1	0	1	10
Mission	1	1	1	3	4	10
Strategic Objectives	0	1	0	3	6	10
Values	0	1	1	4	4	10

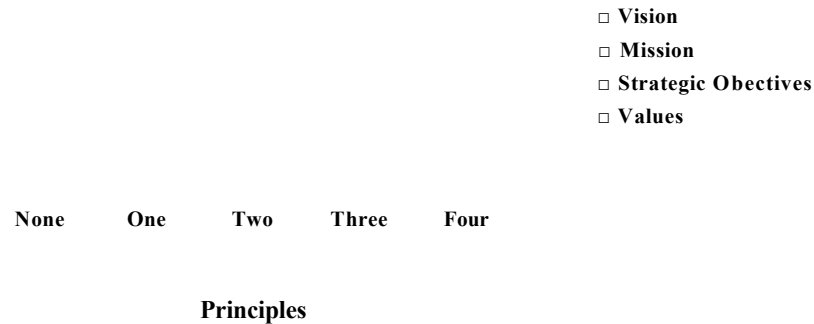

Fig. 20 - Number of TQM Principles included - CE1 page 102

This figure shows:

Vision - as only two TECs had written Visions, eight had not.

Mission & Strategic Objectives - were mainly strong on TQM principles.

Values - Verbal values were again mainly strong, however see also page 108.

Table 12 - Knowledge of organisations' vision, mission, strategic objectives and values - T1 page 104

	SENIOR			MIDDLE			JUNIOR		
	No	A little	Yes	No	A little	Yes	No	A little	Yes
Vision	10	0	0	10	0	0	10	0	0
Mission	1	2	7	3	1	6	4	3	3
Strategic Objectives	1	2	7	5	1	4	3	5	2
Values	4	5	1	2	8	0	5	5	0

- Vision
- Mission
- Strategic Objectives
- Values

N = No
L = A little
Y = Yes

N L Y N L Y N L Y
SENIOR MIDDLE JUNIOR

Fig. 21 - Knowledge of organisations' vision, mission, strategic objectives and values - T1 page 104

This figure shows:

Vision - not one member of the team knew what their organisation's vision was.

Mission & Strategic Objectives - the higher up the organisation the more likely one is to know these.

Values - there is little knowledge of the organisations' values by any of the teams.

Most chief executives could articulate a Vision - a picture of what they wanted their organisation to look like - although none of their teams could. As only two organisations had produced a written Vision, this is not altogether surprising.

Missions were strongly constructed and well articulated by senior and middle management; junior staff were not so clear.

Strategic Objectives were well set out and were well known, in the main, by senior managers; not so for middle and junior staff.

Values only three out of the ten organisations possessed a written record of their Values, although all chief executives volunteered their beliefs of what the organisations' Values were. The table below shows the chief executives' perceptions of what they believed their values were compared with the perceptions of their staff. A multiplier has been used so that a comparison can be made between the ten chief executives and all thirty of the staff questions. There were a higher number of Values articulated by chief executives than by staff.

Table 13 - Comparison of Chief Executives' and their staffs' perceptions of their organisations' Values
 - CE1 page 102 and T1 page 104

		No. of times quoted by	
		Chief Executives	Team Members
1	Customer orientated	160	140
2	Hardworking/objective	168	110
3	Innovative/Continuous Improvement	96	110
4	Professional/Impartial	120	80
5	Partners/Socially Conscious	72	60
6	Leader/Quality	72	50
7	Business Orientated	0	30
8	Empowered	120	20
9	Complex	0	10
10	Shrinking	0	10
11	Keeping Abreast of Issues	0	10
12	Communication Problems	0	10
13	Paper Driven	0	10
14	Openness	148	0
15	Trust	72	0
16	Good Communication	120	0
17	Celebrating Success	24	0

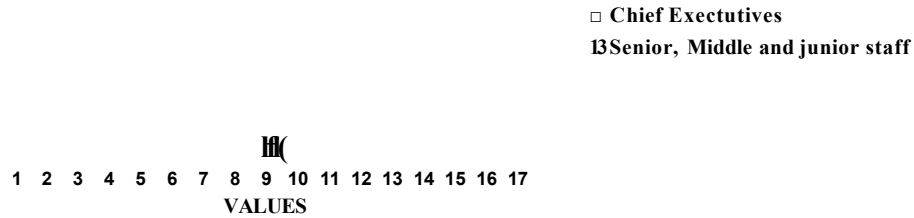

Fig. 22 - Comparison of Chief Executives and their staffs' perceptions of their organisations' Values

This figure shows:

Although 'customer orientated', 'hardworking and objective', 'innovative and continuously improving' and 'professional and impartial' were seen as clear values by both chief executives and staff; 'empowered', 'openness', 'trust, and 'good communications' were values the chief executives felt that their organisations stood for yet almost unnoticed by staff at all levels.

How effective did the Chief Executive believe the organisation's policy and strategy was ? - CE 10 page 103

Table 14 - Chief Executives' perceptions of their organisation's Policy & Strategy

Percentage	No of Org'n
10	0
20	0
30	3
40	0
50	1
60	1
70	2
80	2
90	1
100	0
Total	10



Fig. 23 - Chief Executives' perceptions of their organisation's Policy and Strategy.

This figure shows is that there is a wide variation in the chief executives' perception of the effectiveness (for example: 50% of the chief executives perceive that their organisation's Policy & Strategy is less than 70% effective) of their Policy and Strategy even although the Mission and Strategic Objectives are relatively strong (see Table 12, page 107). The reason for this disparity may be that when this research was carried out TECs were relatively new organisations.

What ownership do you, staff members, feel you have for the policy and strategy of your organisation? - T2 page 104

Table 15 - Feeling of Ownership of Policy & Strategy by staff

Percentages	Senior	Middle	Junior
10	0	0	0
20	0	0	1
30	0	1	1
40	0	1	2
50	0	0	2
60	1	2	0
70	2	4	1
80	1	2	1
90	5	0	1
100	1	0	1
Total	10	10	10

- Senior
- Middle
- Junior

10 20 30 40 50 60 70 80 90 100
 Percentage feeling of ownership of staff

Fig. 24 - Feeling of ownership of Policy and Strategy by staff

- T2 page 104

This figure shows that, in general, the higher one is in the organisation the more ownership is felt for the Policy and Strategy. For example, 70% of junior staff feel less than 80% ownership, whereas for middle management this figure is 80% and for senior management it is only 30%.

Feelings of ownership were, as one might expect, stronger the higher up the organisation one was. The persistent reason for feelings of 'low ownership' was a feeling of 'lack of involvement' - yet substantial energies were expended in this area:

How does our policy and strategy reflect feedback from staff and internal teams? - CE2 page 102

Some twenty-one assorted teams were identified by chief executives:

STRATEGY WORKSHOPS

Some for 'top teams', others for selected staff and some to inform and involve all staff.

STAFF WORKSHOPS

Usually focused on specific issues.

CHIEF EXECUTIVE'S MEETINGS

Usually this was a regular meeting held which included all members of the top team.

MANAGER'S MEETINGS

Sometimes including the chief executive, sometimes not. Mainly used to ensure all managers were kept 'up to speed' on progress.

'CONTACT DAYS'

Regular meeting for all the team.

STAFF/TEAM MEETINGS

Regular team/section meetings usually weekly or monthly.

CROSS-FUNCTIONAL MEETINGS

Staff brought together to deal with specific cross-functional issues.

INFORMAL FEEDBACK

Unscheduled meetings, 'encounters' between manager and team members.

STAFF ATTITUDE SURVEYS

Annual process, just being formulated in a number of TECs.

'ANNUAL CELEBRATION EVENTS'

An 'away from the office' day to calibrate success to date and also to update all staff on progress and challenges ahead.

CORE BRIEFING SYSTEM MEETINGS

'Cascade' briefing from top to bottom of organisation - usually monthly.

WORKING GROUPS

Teams brought together with a specific task to achieve

BOARD MEETINGS

Statutory meetings attended by non-executive directors, chief executive and usually all other members of the top team.

STRATEGY & DEVELOPMENT TEAMS

Team specifically to address compilation of strategic plan.

JOINT CONSULTATION COMMITTEES

Cross-functional team consisting of all levels to address internal issues.

APPRAISAL SYSTEMS

Annual appraisals, initially the same or similar to that used by the Civil Service.

'AWAY DAYS'

Usually used by 'top team' members to take away their team for training, refocusing and action planning.

I.I.P. GROUPS

Brought together to plan and monitor progress towards implementation and achievement of the I.I.P. (Investor in People) Award.

DAILY SENIOR MANAGERS' MEETINGS

Top team meeting to ensure co-ordination within the organisation.

To assess whether communication was uniformly effective across all organisations investigated, the following question was asked:

The following was my assessment, after investigating the number and variety of teams and methods of communication:

Table 16 - Effectiveness of Policy and Strategy communication

No visible sign	0
Weak	0
Less Strong	3
Strongly	7
Total	10

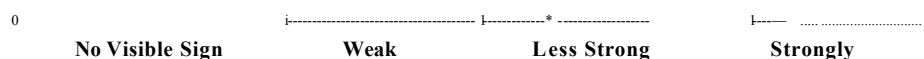

Fig. 25 - Effectiveness of Policy and Strategy communication.

This figure shows that Policy and Strategy is mainly strongly communicated. The question this raises is: As communication is strong, yet the lower one goes in the organisations the less ownership there is for Policy and Strategy, how competent are those who are communicating? (Little training is given in this area; as can be seen in Fig. 32, page 131)

In many teams - see the answer to the previous question - however, there was almost no monitoring of the quality of presentation or content of managers briefing the teams, nor was training provided to enhance presentation skills.

5.3 LOYAL CUSTOMERS

Loyal customers are achieved firstly by identifying who are our customers then agreeing and meeting their needs, consistently.

As can be seen from the following, the TECs' challenge is the volume and variety of customers. For although each organisation has its own definition of who their customers are, all include every individual in their area:

Who are your customers? - CE2 page 102

The following represent the variety of comments received from chief executives:

- Primary: Business, Secondary: Individuals, Thirdly: TEED, etc. (the people who pay)
- Customers are all individuals, companies and training organisations in this area.
- All individuals and businesses. TEED is our banker.
- Providers and businesses in the area.
- TEED and the community. The community is split into unemployed, business, education and individuals at work.
- Unemployed and business can be further divided into those starting up businesses and small businesses.
- Primary: Business in area (these are who I am accountable to). Secondary: Trainees. Thirdly: the general community, in particular 'the great and the good' and 'the decision takers' (the wider community is not consulted).

- Primary: TEED and DTI. Secondary local businesses and people.

To better understand these customers a variety of mechanisms had been put into place, they include:

A number of consultation teams working with business and the community, area advisory committees, consultation and advisory teams, consultation presentations and feedback - including the AGM. Many working parties and advisory groups, associate memberships, questionnaires, research, public meetings, newsletters, newspapers, a business exchange, Investor in People visits, individual discussions, specialist groups, business awareness studies and National TEC groups.

The feeling of chief executives was that 'it is early days' and in time, as the process of TECs is better understood; fewer more effective groups might emerge.

The same difficulty arose with suppliers: When asked:

Who are your suppliers? - CE2 page 102

The following comments were received from chief executives:

- Training providers, consultancies used by the TEC. The key is that they influence our customers.
- Providers of training and services to our TEC;
- Training providers, including universities, colleges, institutions, including schools, and associate consultants who have gone through our quality process.

The methods used to communicate with suppliers are again various, they include: enterprise conferences, training for work days, consultative documents, regular meetings, sporadic meetings, suppliers forum, chief executive visits, consultants' forums, and business advisors forums.

Chief executives said of suppliers:

- We spend a lot of time listening; - they would say we don't consult but we do.
- We are reactive at present.
- TECs are seen as imposing on them.

The conclusion of chief executives was that one could never do enough networking and consultation with customers, either inside or outside of the organisation; they felt that, with the resources they had, they covered a great deal of ground.

5.4 TEAMWORK

The question asked of senior, middle and junior staff was:

How much do you feel appreciated by your organisation? - T3 page 104

Table 17 - Feeling of Appreciation

Percentages	Senior	Middle	Junior
10	0	0	1
20	0	1	1
30	0	0	2
40	0	0	2
50	0	1	1
60	1	2	0
70	2	3	2
80	5	1	0
90	2	2	1
100	0	0	0
Total	10	10	10

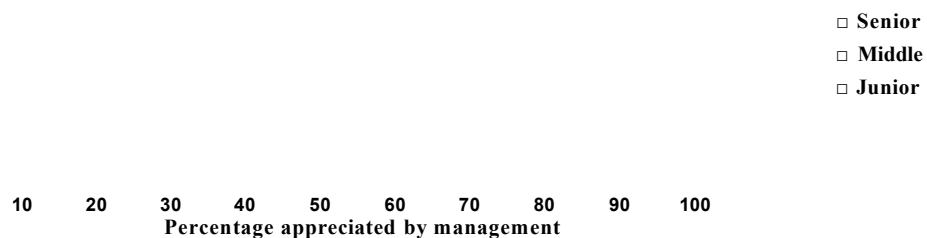

Fig. 26 - Feeling of Appreciation

This figure shows that the higher up the organisation one is generally the more appreciated one feels. For example, 90% of junior staff feel less than 80% appreciated, whereas the equivalent figure for the middle manager is 70% and for senior managers this figure is merely 30%

The major reason given for feeling of lack of appreciation was a feeling of not being involved and recognised.

Chief executives were asked:

What methods do you use to motivate your people? - CE9 page 103

Then staff were asked:

What motivates you? - T4 page 104

The table below captures both answers:

Table 18 - Methods of motivation against staffs' beliefs upon how they perceive that they are motivated.

		What motivates you	
		Ch.Ex. perception	Staff beliefs
1	Praise, Recognition, Managing by walking about	10	5
2	Salary, bonus awards	10	2
3	Teamwork	5	4
4	Appraisals	4	1
5	Job rotation	2	0
6	Training, Development	2	3
7	Successful organisation	2	5
8	Delegated responsibilities	1	2
9	Working Environment	1	0
10	Supportive, Contributing, 'worthy' projects	1	4
11	Open communication	1	0
12	Personal Example	1	0
13	Job satisfaction, Self fulfilment	0	10
14	Loyalty	0	2

□ Chief executives perceptions
○ Staffs' beliefs

3

Fig. 27 - Methods of motivation against staffs' beliefs upon how they perceive that they are motivated.

- CE9 page 103 and T4 page 104

This figure shows that Chief executives believed that praise, recognition and managing by walking around are the primary method of motivation; and also salaries, bonuses and awards.

Team members, at every level, believed that their prime motivation came from job satisfaction and self-fulfilment from a job well done. This begs the questions: 'Is it a priority - that this research shows that it should be - to focus on job design and measures so that individuals can monitor their own job performance?' (This area needs more research work). - see 8.5 page 154

So how do we evaluate and improve effectiveness of communication?

- CE3 page 102

Table 19-Evaluation and improvement of communications effectiveness

No visible sign	0
Weak	1
Less Strong	8
Strongly	1
Total	10

No Visible Sign Weak Less Strong Strongly

Fig. 28 - Evaluation and improvement of communications effectiveness

This figure shows that there is some way to go to tighten this area; however, action is being taken by some TECs.

Answers ranged from ‘evaluation is a National developmental project so it will be done’ to ‘walking about instinctively closes the loop’ to ‘we have faulty performance indicators.’

In answer to the question:

What could your organisation do even better? - T5 page 104

The staff's main area of concern was that of communication:

- Our organisation is split, we need to work more with other departments
- We are still in little boxes
- We must get rid of 'us' and 'them', by having meetings for all levels
- They need to filter down information from senior managers' meetings
- We need more contact by the top with the bottom of the organisation
- Not enough attention paid to junior people - there's a big distance
- We need more bottom up formal communication
- We feel quite isolated in our teams
- The organisation needs to respond to our needs too

5.5 MANAGEMENT BY FACT

Questions then focused upon whether agreed policy and strategy was built into business plans; whether they were evaluated and if managers communicated by the use of TQM methods and whether they monitored awareness of Total Quality in their organisations?

How do you ensure that your policy and strategy is reflected in your business plan? - CE4 page 103

Table 20 - Policy and Strategy reflected in business plan

No visible sign	0
Weak	0
Less Strong	2
Strongly	8
Total	10



Fig. 29 - Policy and Strategy reflected in business plans

This figure shows that as one would expect, these are impressively strong - for this is part of Government's monitoring process. There was an area where concern was being expressed; it is reflected in this observation by a chief executive:

Splitting down the operational plan to each staff member works well. What does not yet work so well is ascertaining that the total of all individual achievements add up to an integrated advance towards our aims and mission. - see 6.4.4 Feedback page 145 and 6.2.3 Feedback loop page 139.

To ensure that not only the business plan has been planned and carried out, this question was asked to ensure it was also 'studied':

How do you ensure that your policy and strate2V is regularly evaluated for its effectiveness and relevance? - CE5 page 103

Table 21- Effectiveness and relevance evaluated of Policy and Strategy.

No visible sign	0
Weak	0
Less Strong	6
Strongly	4
Total	10

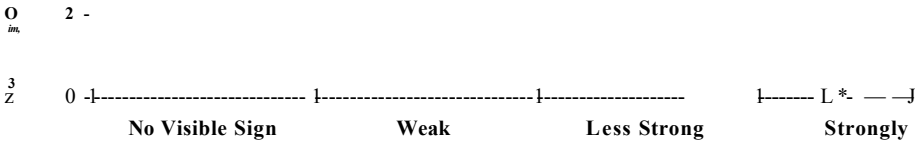

Fig. 30 - Effectiveness and relevance evaluated of Policy and Strategy.

This figure shows this is another area which is of strong interest to Government and thus one would expect strong evaluation processes. However, this strength is not always reflected in the chief executives comments, they range from: ‘Evaluation is considered in depth once a quarter by the executive team’ to ‘It is only happening ad-hoc.’

Do your managers use Total Quality methods to communicate and involve their team? - CE7 page 103

Perhaps this question was not relevant as only one of the ten organisations was training their staff in Total Quality.

Brainstorming was the method most consistently used with histograms coming a close second. There was no consistency of use of tools throughout any of the organisations: Motorola states that 'if a process is not flowcharted it is not understood.' Not one organisation had flowcharted their processes.

Chief executives observed:

- Presently, procedures are being flowcharted
- Some do total quality methods some do not
- Variable
- We are radically changing our appraisal system
- Keep things simple, there is too much bullshit

To the question:

How do managers ascertain awareness of Total Quality within your organisation? - CE8 page 103

The key response was 'T.Q. methods are not taught, thus we can't evaluate awareness.' - see 6.1.3 Education (Competence) page 135.

5.6 CONTINUOUS IMPROVEMENT

TECs had only recently been set up at the time of these questionnaires so there was a great deal of change going on, however, two questions were thought to be relevant; the first to chief executives and the second to team members:

How do you link your policy and strategy with your drive for excellence in the service you provide? - CE6 page 103

Table 22 - Link between Policy & Strategy and drive for excellence

No visible sign	0
Weak	2
Less Strong	7
Strongly	1
Total	10

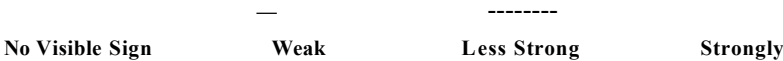

Fig. 31 - Link between Policy and Strategy and drive for excellence

This figure shows that there is still some way to go here as can be seen from comments of chief executives:

- We are still searching for exactly what service we should be providing.
- We know from feedback that our organisation is highly regarded.
- We've got a hell of a lot to do.

A tangible way to improve effectiveness of one's organisation is through training, so this three-part question was asked of all staff:

Whilst with the organisation have you participated in: - T6 page 104

Formal training?

Leadership training?

Communication or teamwork training?

Table 23 - Formal Leadership & Communication/Teamwork training

	Senior	Middle	Junior
Formal - No	1	1	1
- Little	0	2	2
- Yes	9	7	7
Leadership - No	7	10	10
- Little	0	0	0
- Yes	3	0	0
Communication/ Teamwork - No	5	8	8
- Little	0	2	1
- Yes	5	0	1

- Senior
- Middle
- Junior

No	Little	Yes	No	Little	Yes	No	Little	Yes
Formal training			Leadership training			Communication/Teamwork		

Fig. 32 - Formal Leadership and Communication/Teamwork training

This figure shows that considerable formal training took place - mainly in skill areas including health and safety, and computer competence.

Leadership training was confined to just three of the senior executives out of the thirty team members interviewed.

Communication and teamwork training, again was restricted to half of the senior team interviews, see page 130.

Two further questions were added to identify if the organisations 'benchmarked.'

Here are some of the chief executives comments, which shows that a few ad-hoc benchmarks are done:

- The chief executive is a friend and thus we swap notes
- None except via TEED
- What matters is our own measure: the impact on our area
- Future visits will take place, with the chief executive of our local Chamber of Commerce, to our opposite numbers in three other areas
- League tables are taken seriously
- Benchmarks will be produced by the Regional Director
- Not done formally at all
- We don't do this (said by two chief executives)
- No, but we should.

CHAPTER SIX: GENERAL CONCLUSIONS

6.1 LEADERSHIP

6.1.1 DIRECTION (PURPOSE)

Requirement

A shared direction or purpose is the first prerequisite of an excellent organisation (see 3.4.1, page 73) thus, what is needed is a clear vision or mission, understood and shared by all of the team.

Findings

The lower one was in the organisation the less likelihood there was that the direction or purpose of the organisation was known or understood (see 5.2, page 105).

Recommendation

More work is needed, especially with the lower end of the organisation. The purpose should be referred to at each team meeting, it should be known, understood and owned by all staff. Thus, it needs to be 'seen' as pivotal to all staff. At least once a year, with all team members present, the chief executive should explain it and its importance and the team should together commit themselves to its ownership.

6.1.2 VALUES (INTEGRITY)

Requirement

Decisions, within an organisation, need to be made often with no-one to turn to for advice and guidance. Guidelines, 'a compass' or a 'touchstone', are needed to ensure that the decision is 'right' for the organisation. These 'touchstones' are, firstly, the organisation's direction or purpose; and, secondly, its shared values.

Findings

Values were much in evidence within the organisations: and when asked, all had a clear picture of their perception of the values that the organisation stood for. Unfortunately, these did not always coincide throughout the organisation - (see Table 13, page 109 and Fig. 22, page 110).

Recommendation

At a meeting, at which all of the team attend; together they should decide upon their shared values. One of the most straightforward ways of doing this is to brainstorm then to reduce the number to a manageable size (see page 77 - Integrity).

6.1.3 EDUCATION (COMPETENCE)

Requirement

A rolling programme - for all personnel within the organisation, including the board and chief executive - is required in both skills for each specific job being carried out and education in total quality concepts, processes and tools, teamwork and leadership skills. This will ensure a common language amongst the team: 'the way we do things around here.'

Findings

These range from one organisation educating staff in both TQM and teamwork and leadership skills to others where little or none of this is taking place (see Table 23, page 130 and Fig.32, page 131). 'T.Q. methods are not taught thus we can't evaluate awareness.' - page 128.

Recommendation

Not only install this rolling programme but ensure that it is used. For example, the Quality Circle (see Fig.9, page 82) can be used at each project meeting; the Ishikawa diagram (see Fig. 18, page 96) at each team briefing; flow charting (see Fig.17, page 95) the key processes and regularly review and improve them.

6.1.4 COURAGE AND CONSIDERATION (MATURITY)

Requirement

Courage of all team members to achieve their task and consideration for those internal and external customers to feel involved, respected and trusted.

Findings

Many internal and external teams addressing both the organisations' tasks and the involvement of internal and external customers, and yet still there were mixed feelings about ownership: 'the persistent reason for feelings of low ownership was the feeling of lack of involvement' - page 113.

Recommendation

Each team to define:

- What the team's purpose is
- Specifically who their customers are
- What their customers' requirements are
- What their customers' specifications are
- Agree a clear action plan, including who will do what and by when
- Agree clear measures before commencing the work
- Define and carry out training needed for team members
- Carry out the work and measure
- Analyse, evaluate and improve the process

Note that this follows the 'quality circle' process (see Fig.9, page 82) and also gives the team job satisfaction and self-fulfilment (Table 18 - page 121).

6.2 LOYAL CUSTOMERS

6.2.1 CLARIFY

Requirement

The first step to achieving loyal customers is to identify who one's customers are.

Findings

The Governments' definition of TECs' customers was: 'the businesses that operate in their local area, and local people' (see 2.3, page 22). Each organisation did either have a definition or the chief executive was prepared to give one. However, they are not the same as the Government definition or their fellow organisations; in fact, they vary widely (see 5.3, page 117).

Recommendation

The Regional Director to emphasise why the Government's definition needs to be adopted, at an area meeting with chief executives and chairmen. Or, at that meeting, to brainstorm and agree a common definition to give the organisations a clear shared focus.

6.2.2. RELATIONSHIPS/NEEDS

Requirement

Clear understanding of customer needs - and organisations' needs of the customer - agreed, written down and measured against.

Findings

More work is needed to ascertain how teams are co-ordinated, (see 5.2,5.3 and 5.4, pages 105 to 121) whether they identified clearly customer needs, etc (see 6.1.4, page 136). It is likely that, with the large number of teams operating, structures had been put in place but the processes - including feedback loops - needed strengthening.

Recommendation

Agree joint objectives, similar to 6.1.4 on page 136 for each team meeting. There also needs to be a system of monitoring these teams: to evaluate their effectiveness towards the organisation's purpose.

6.2.3 FEEDBACK LOOP

Requirement

Detailed facts from customers to ascertain their perceptions of the effectiveness of the service that they are receiving, and process for analysing, evaluating, improving and updating the written down processes.

Findings

A variety of methods from use of teams (see 5.2 and 5.3, pages 105 to 119); to staff surveys and customer surveys. There is, however, little 'hard data', 'we are reactive at present', '(The senior management) need to respond to our (junior staff) needs too';

Splitting down the operational plan to each staff member works well. What does not yet work so well is ascertaining that the total of all individual achievements add up to an integrated advance towards the aims and mission - page 126.

Recommendation

Each key process to be revisited and the feedback process checked and strengthened if required. Customer and employee surveys to be thought through and used to gain facts, upon which to make decisions. Star model to be used by all organisations to analyse present position, identify gaps and clarify areas which are most urgent and important for improvement.

6.3 TEAMWORK

6.3.1 TRUST

Requirement

With agreed direction, values, competence and maturity - (see 6.1, page 133) we have role-models (see 3.4.1, page 73). What, however, is also needed is to 'care': to agree joint win/win agreements with customers (see 3.4.1, page 73) - to 'seek first to understand before being understood' - in other words to 'listen' (see 3.4.3, page 86) and to appreciate each person for the talents they bring.

Findings

Trust was not a value recognised by the staff in the organisations (see Table 13, page 109). However, it was my perception that staff did not so much lack trust in the organisation as a feeling of appreciation. Without exception, in my perception, the 'top teams' were hard working and committed to their tasks.

Recommendation

Training in teamwork and communication skills (see Fig. 32, page 131) - is needed at all levels (see 6.3.2, page 141).

6.3.2 COMMUNICATION

Requirement

Strong simple regular and disciplined process for communicating with the team.

Findings

A variety of methods, the main observation was that after the ‘top team’ briefing each manager was left to carry out his/her own briefing with no formal briefing notes, no training in briefing, no monitoring of the effects of the briefing and little or no feedback from staff.

Recommendation

Install: formal system of briefing (see Fig, 16, page 91), train managers how to brief and use of simple TQM tools (see 3.4.4, page 93) - to use in team meetings. Formalise processes used throughout organisations including quality cycle, win/win agreements, action planning and meeting review procedures.

6.4 MANAGEMENT BY FACT

6.4.1 PROCESSES

Requirement

Each process to have an aim, the process is towards servicing the customer - the organisation's structure should reflect this. A few simple process tools to be used and standardised throughout the organisation.

Findings

Flow charting either not being used or being commenced, also organisations structured in traditional cascade format. TQM tools not standardised and often not used.

Recommendation

Flowchart key processes; install ongoing training in TQM and formalise tools - effects will be substantial if what the authorities say on page 97 proves correct!.

6.4.2 VARIATION

Requirement

Measure variation on the key processes and standardise processes throughout organisation.

Findings

Great activity in many groups throughout the organisations (see 5.2 and 5.3, pages 105 to 119); there are many variations throughout the processes because of lack of understanding of:

1. The purpose of each organisation (see page 107).
2. The methods of motivation (see page 121).
3. The importance of using TQM tools consistently.
4. The organisations' values.

Recommendation

Install flow charting for all key processes with a formal feedback system (see page 95). Also, install, and standardise throughout the organisation, TQM tools to measure, analyse and evaluate the processes.

6.4.3 PRIORITIES

Requirement

Rather than ‘change the world’ immediately by trying to get everything right now; focus upon getting one thing right at a time. In other words, don’t go for ‘one mile wide and one inch deep, go for one inch wide and one inch deep’ (Saying of Peter Scholtes)

Findings

Lots of activity on all fronts but such activity may have a lasting effect upon their image: ‘fewer more effective teams may emerge’ (see page 118), they say we don’t consult, but we do’ and ‘TECs are seen as imposing on them’ (see page 119).

Recommendation

Using the Ishikawa diagram (Fig 18, page 96), brainstorm each critical success factor - or strategic objective in the case of the organisations researched - see the ‘effect’; and list all the ‘causes’ that will achieve that outcome. Then decide upon which is the most urgent and important ‘cause’, draw up an action plan and follow that through until bottomed - then move on to the next most urgent and important ‘cause.’

6.4.4 FEEDBACK

Requirement

Every process installed has a formal feedback loop both to the team responsible and, from them, to the controlling group.

Findings

‘Walking about instinctively closes the loop’ (see page 123). It was my perception that staff had not been asked ‘how the organisation could do even better’ (see page 124). The TECs had good processes too: ‘we know from feedback that our organisation is highly regarded’ (see page 130).

Recommendation

As with 6.4.2, page 143: install flow charting for all key processes with a formal feedback system (see page 95). Also, install TQM tools to measure, analyse and evaluate the processes.

6.5 CONTINUOUS IMPROVEMENT

6.5.1 CIRCLES

Dealt with under feedback (see 6.4.4, page 145 and 6.5.2, page 146).

6.5.2 FEEDBACK

Requirement

Not only is a feedback loop needed within an organisation and with customers and suppliers, there is a need to have a system of benchmarking with similar and diverse organisations to ensure that one's own processes reflect 'best practice'.

Findings

Some 'ad hoc' benchmarking took place in some of the organisations researched (see page 132).

Recommendation

At national and regional levels, 'best practice' should be gathered and circulated - similar to the RSA's work in Industry Year 1996 (RSA 1995)

Locally a 'best practice group' set up - say with other Investor in People organisations (see page 115); however, for the specific objective of sharing and spreading 'best practice.'

6.5.3 LESSONS LEARNED

Requirement

‘Everything that happens once can never happen again. But everything that happens twice will surely happen a third time!’ (Coelho 1988)

Lessons learned, in a formal feedback system need to be documented, actions taken to improve and improvements documented into new processes. Also, remember to celebrate achievements made!

Findings

My perception was that the organisations had their own momentum, there was a great deal to do and achieve. Time for standing back and thinking through lessons learned was not seen as a priority - there was so much to do.

Recommendation

Build in a half-hour daily team meeting to cover: achieved yesterday; barriers to overcome; actions agreed to overcome barriers and tasks for today (see page 92). Also, build into every team meeting, a review process (see page 84). For the top team, up to half a day a week is needed on their own to carry out this same process that teams are undertaking daily. Further, they require at least a full two days review each quarter to give themselves space to stand back and look at the organisation at arms length.

Finally, as a number of the organisations do; at least once a year, the whole team should take at least a day: - to review; where they were a year ago, what they have achieved in these past twelve months and lessons learned, and where they are now. Then they should celebrate their processes and achievements: the joy of working constantly together towards a common purpose - Deming's first and twelfth points - with integrity, competence and maturity (see 3.4.1, page 73).

CHAPTER SEVEN:

SPECIFIC CONCLUSIONS AND SUMMARY RECOMMENDATIONS

7.1 CONCLUSIONS

In all the organisations researched the individuals were: hard-working, generally good-humoured, committed, wanting to achieve more, goal-orientated and caring.

However, often they were also: unaware of the organisation's clear purpose, did not have shared values, were unaware of their organisation's priorities so worked at the achievement of all their objectives, also were confused as to who specifically their customers were. Each felt part of a team but often not part of the organisation's full team.

In general, the organisation's key processes were not clear - and certainly were not set down (see flowcharting, page 95), and its structure was orientated towards a cascade rather than customer-driven organisation. There were no standardised tools to be used throughout each organisation and, in my perception, no formal feedback systems for each key process; nor were there, generally, formal briefings with a formal feedback system - coupled to this there was no training for managers in briefing and monitoring nor full team training in leadership and teamwork.

Finally, there was little - and no formal - benchmarking with fellow, local or national organisations.

There is no doubt in my mind as to the high calibre and energy of the teams and effectiveness of all the organisations reviewed. However, with just a few simple changes, it is my belief that, these good organisations could achieve a great deal more for their customers and become ‘role models’ that other organisations would look to to benchmark against.

Further, all the lessons learned and recommendations in this Thesis are just as applicable to any medium-size organisation as they are for TECs. In fact, perhaps they have even more incentive than TECs to adopt these findings for, as stated on page 25, Sections 2.6.1 and 2: it is in TECs that one would expect to find ‘best practice’. So other medium-size organisations may make even greater improvements than the TECs will by adopting these recommendations.

7.2 SUMMARY RECOMMENDATIONS

Purpose and values

Gain ownership by preferably producing together an inspiring way forward and certainly briefing regularly. They should be referred to constantly, explained and discussed regularly. (pages 133 and 134)

Competence and caring

All the teams require training: not only in skills for each specific job but also in the use of TQM tools, leadership, communication and teamwork (see page 135).

Structure and processes

To understand the key processes and the structure needed to support those processes, the first step is to flow-chart these processes and identify a clear aim for each process (pages 142 and 143), then to use the 'quality circle' (see page 136) to learn from and enhance the process.

Prioritise and reduce costs

By using three of the seven TQM tools, namely brainstorming and the Ishikawa and Pareto diagrams - clarity of priorities for each team can be focused upon. By using these, plus the other four tools; variation will reduce, speed of process delivery will increase and, thus, costs will inevitably reduce. These tools and quality processes must be part of each team's essential tool kit - so that all of the organisation is using the same simple tools and techniques and using the same simple processes (page 143) - unlike the researched situation where managers are left to run meetings in a variety of ways.

Agree who customers are

At the time of research, the organisations had the unenviable task of trying to be 'all things to all people' and feeling, naturally, inadequate in the task. Further research is needed, before recommendations can be made, to identify who exactly customers of the TEC really are. - see 6.2.1 Clarify page 137 and 8.2 page 153.

CHAPTER EIGHT:

FURTHER RESEARCH NEEDED

A metaphor for what still needs to be done is that of a lit candle in the dark:

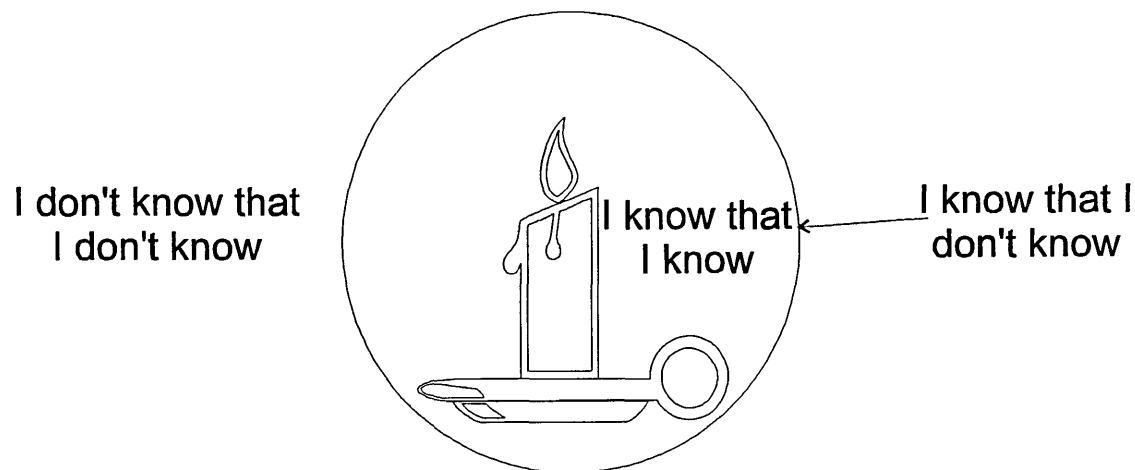

Fig. 33 - Knowledge model.

What this picture shows is the more 'I know that I know' (the brighter the candle), the more 'I know that I don't know' (the larger the circumference). The darkness outside the circle of light represents 'I don't know that I don't know'. Here are a few key areas that need more work - because 'I know that I don't know'!

8.1 UPDATE

This research was completed by the end of 1993, it is therefore already in need of being updated, for at that time none of the organisations had been in existence for more than three years and were still establishing themselves - now they should be fully 'bedded in.'

8.2 CUSTOMERS

At the time of research, there was a wide disparity between the Government's definition of who the organisations' customers were - page 22 - and who the organisations thought they were - page 117.

Work is needed to agree a common definition and also to agree the 'best' feedback mechanisms for measuring customer loyalty. (see also page 137)

8.3 BEST PRACTICE

The gathering together of organisations' best practices and sharing of this information would be a 'gold mine' for hard-worked team members. Research is needed upon how this can be carried out; nationally, regionally and/or locally. (see also page 146)

8.4 TQM ORGANISATION

Research comparing a medium-size organisation with and without a TQM philosophy, processes and tools is needed. For not one of the organisations researched had this TQM philosophy although one - which was researched again in 1994 - was found to be implementing some TQM practices and was making identifiable improvements.

8.5 MOTIVATION

Staff believe that they are motivated by job-satisfaction and self-fulfilment from a job well done - pages 121 and 122. Research is needed to see how both job design and measures can be installed and continuously improved so that individuals can monitor their own performance effectively.

Footnote:

I have learned a great deal, thanks to this degree process, yet as Aristotle used to say; 'I know nothing'!

**VISITS TO ORGANISATIONS
FOR INTERVIEWS AND TO GIVE FEEDBACK ON FINDINGS**

ORGANISATION GIVE	ORIGINAL VISIT	VISIT TO FEEDBACK
<i>A</i>	<i>28.6.93</i>	<i>17.11.93</i>
<i>B</i>	<i>30.6.93</i>	<i>19.11.93</i>
<i>C</i>	<i>22.7.93</i>	<i>16.11.93</i>
<i>D</i>	<i>29.7.93</i>	<i>13.12.93</i>
<i>E</i>	<i>9.8.93</i>	<i>17.12.93</i>
<i>F</i>	<i>19.8.93</i>	<i>24.11.93</i>
<i>G</i>	<i>23.8.93</i>	<i>24.11.93</i>
<i>H</i>	<i>24.8.93</i>	<i>15.12.93</i>
<i>I</i>	<i>24.8.93</i>	<i>15.12.93</i>
<i>J</i>	<i>7.9.93</i>	<i>24.11.93</i>

ORIGINAL VISIT:

Interview of Chief Executive plus three team members

VISIT TO GIVE FEEDBACK:

Presentation to Chief Executive and any of his team that he had invited to the meeting (see page 17)

1. INTERVIEW WITH CHIEF EXECUTIVE

	Continuous Improvement	Management by Fact	Teamwork	Loyal Customers	Total
Vision	0	0	0	0	0
Mission	0	0	0	0	0
Strategic Objectives	1	1	1	1	4
Values	1	1	1	0	3

The above statements (for example Vision) were examined within each TEC to see if they contained each of the principles set out in the star model - see page 71.

If the principle existed within the statement then a score of one was allocated. If the principle was not present then a score of nil was given.

These figures can be confirmed with the help of the report and accounts produced and published by each TEC.

This form provides the information incorporated into Table 11, page 106.

2. INTERVIEWS WITH CHIEF EXECUTIVES AND TEAM MEMBERS

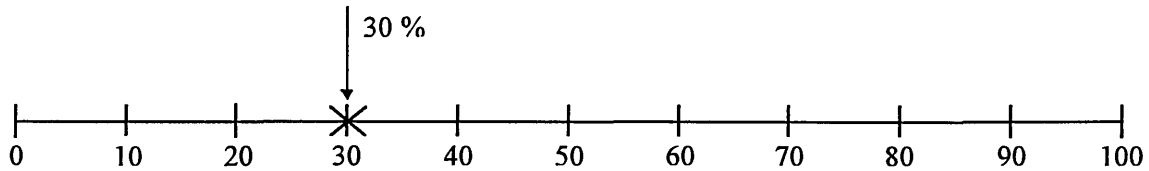

The interviewee was asked to place a cross on this line in answer to the following two questions:

T2 *What ownership do you feel for the policies and strategies of your organisation?* - see Table 15, page 112.

T3 *How much do you feel appreciated by your management?* - see Table 17, page 120.

This process was also used whilst interviewing Chief Executives:

CE10 *How effective do you believe your organisation's policy and strategy is?* - see Table 14, page 111.

The above chart shows that the Chief Executive felt that his organisation's policy and strategy was 30% effective. For fuller explanations see information set out with each table.

3. INTERVIEWS WITH TEAM MEMBERS

What is your orgn's	No	A little	Yes
Vision	1		
Mission		1	
Strategic Objectives			1
Values		1	

A score of one was given in whichever column reflected the interviewee's answer.

Thus, if the interviewee did not know what the vision was then one would be placed in the 'No' box.

The above scores show that the individual interviewee did not know what the vision was, had a little knowledge of both the mission and values of the organisation and did know what the TECs strategic objectives were

The full interview results are given in Table 12, page 107.

4. The data collected in Tables 19 - 23, pages 123 - 130 all follow a similar format to Number 3 in Appendix B.

REFERENCES

ADAIR J (1983)

Effective Leadership: A self-developmental manual

(Gower, England)

BARNETT C (1986)

The Audit of War: The illusion and reality of Britain as a great

Nation (Papermac, London)

BDA (1991)

Quality is people not products: (British Deming Association - Audio cassettes of the National Forum 1991, England)

BROCKA B & M.S (1992)

Quality Management: Implementing the best ideas of the Masters

(Business One Irwin, Illinois)

CAMPBELL A., DEVINE M & YOUNG D (1990)

A Sense of Mission: (Century Business, London)

CARLISLE J. A & PARKER R.C (1989)

Beyond Negotiation: Redeeming customer-supplier relationships

(Wiley, Chichester)

CAUX (1994)

Principles For Business:

(Caux Round Table, Switzerland)

COELHO P (1988)

The Alchemist: A fable about following your dreams

(Thorsons, London)

COVEY S.R (1989)

The Seven Habits of Highly Effective People:

(Simon & Schuster, New York)

CROSBY P.B (1987)

The Eternally Successful Organisation:

(TDM/McGraw-Hill, Fullerton, USA)

DEMING W.E. (1986)

Out of the Crisis:

(MIT, Cambridge, Mass. U.S.A)

DEMING W.E. (1993)

The New Economies: for Industry, Government, Education:

(MIT, Cambridge, Mass. U.S.A)

FINNIGAN D (1993)

The Zen of Juggling:

(Jugglebug, U.S.A)

GAARDER J (1991)

Sophie's World: An adventure in philosophy

(Phoenix House, London)

GAGNE J (1986)

American Quality Coaches: A look at their game plans for turning firms into winners (CPI Purchasing magazine, U.S.A. March 1986)

GO AHEAD (December 1995)

The Newsletter of the GO (Golden Opportunity) partnership - constructing offshore wells for NAM (Nederlandse Aardoli Moatshappij B.V.): (Anton M. Jensen, Denmark)

KANJI G.K. & ASHER M (1993)

Advances in Total Quality Management: Total Quality Management Process - A systematic Approach (Carfax Publishing Abingdon, England)

KANJI G.K (1994)

Total Quality Management & Statistical Understanding: Volume 5 number 3 (Carfax Publishing, Abingdon, England)

KANJI G.K/ M. ASHER (1996)

100 Methods for Total Quality Management: (Sage, England)

KOHN A (1993)

Punished by Rewards: The trouble with Gold Stars, incentive plans, A's, praise and other bribes (Houghton Mifflin, New York)

KONDO Y. (1989)

Human Motivation: A key factor for Management (3A Corporation, Japan)

LAO TZU (1993)

Tao Te Ching: The New Translation
(Element Classic Editions, Dorset, England)

MARS (1993)

The Five Principles: In Practice (Mars, Canada)

MUSASHI M (1982)

The Book of Five Rings: The real art of Japanese management
(Bantam, New York)

NEAVE H.R. (1990)

The Deming Dimension: (SPC Press, Tennessee, U.S.A.)

RANK XEROX (1992)

The Rank Xerox European Quality Award Submission Document
1992 (Rank Xerox, England)

RIDENOUR F (1967)

So What's the Difference: between religions
(Regal Books, U.S.A.)

RSA (1995)

Tomorrow's Company: (RSA, London)

SCHERKENBACH W.W (1991)

Deming's Road to Continual Improvement:
(SPC Press, Tennessee, U.S.A)

SCHOLTES P.R (1988)

The Team Book: (Joiner, Madison, U.S.A)

SUN TZU (1963)

The Art of War (Oxford University Press, England)

TOFFLER A. (1990)

Power Shift: (Bantam, New York)

TRAINING AGENCY (1989)

Guides to Planning: Training and Enterprise Councils
(Employment Department, England)

TRAINING AGENCY (1989)

Training and Enterprise: Priorities for Action 1990/91 - Strategic
Guidance from the Secretary of State for Employment
(Employment Department, England)

TREGOE B.A & ZIMMERMAN J.W (1980)

Top Management Strategy: What it is and how to make it work.
(John Martin Publishing, London)

TRIBUS M (1994)

Quality Management in Schools:
(BDA paper, England)

YOSHIKAWA E (1971)

Musashi: (Kodansha International, Tokyo)