

LEARNING CENTRE
CITY CAMPUS, POND STREET,
SHEFFIELD, S1 1WB.

101 659 917 X



Fines are charged at 50p per hour

13 MAY 2003
8.52.

17 MAR 2004
5.07pm

- 9 DEC 2004

7.25pm

16 MAY 2005
4.04pm

16 FEB 2006
4.24

13 MAR 2006

4.15

28 FEB 2007

4.30pm

ProQuest Number: 10694066

All rights reserved

INFORMATION TO ALL USERS

The quality of this reproduction is dependent upon the quality of the copy submitted.

In the unlikely event that the author did not send a complete manuscript and there are missing pages, these will be noted. Also, if material had to be removed, a note will indicate the deletion.



ProQuest 10694066

Published by ProQuest LLC (2017). Copyright of the Dissertation is held by the Author.

All rights reserved.

This work is protected against unauthorized copying under Title 17, United States Code
Microform Edition © ProQuest LLC.

ProQuest LLC.
789 East Eisenhower Parkway
P.O. Box 1346
Ann Arbor, MI 48106 – 1346

**AN ANALYSIS OF TQM
AND
ORGANISATIONAL LEARNING PROCESSES
USING
MODELLING AND SIMULATION**

A thesis submitted in partial fulfilment of the requirements
of
Sheffield Hallam University
for
the degree of Doctor of Philosophy

Hamdy H. Abdelmeguid

School of Engineering
Sheffield Hallam University
United Kingdom

April 2001



Sheffield Hallam University

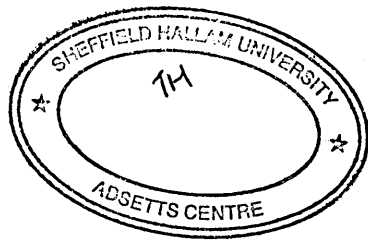

ABSTRACT

The aims of this research are to examine the link between Total Quality Management (TQM) and organisational learning, to develop a conceptual framework for a learning organisation, and to model (Skill Pool Model (SKPM), Pipeline Skill Pool Model (PSKPM), Automated Pipeline Skill Pool Model (APSKPM)) learning processes to facilitate simulation of the effects of key parameters on the skill within an organisation.

This thesis presents an analysis of the fundamental factors and mechanisms of TQM. A comparative study of ten quality Gurus is conducted to establish a link between TQM and organisational learning. This has resulted in the development of a conceptual framework for the learning organisation, using TQM as the baseline. The learning organisation conceptual framework consists of twenty-eight elements (enablers) and nineteen dependent outcomes (results).

The learning organisation conceptual framework is utilised in a questionnaire survey to capture a snapshot of European organisations' efforts to become a learning organisation. Survey results show that the main differentiating factors between TQM and organisational learning are the type of learning tools in use and the information system in place. Further analyses reveal that organisations are experiencing great difficulties in translating organisational learning theory into practice.

The research work uses system causal-loop analysis in conceptualising the three waves of quality, which provide a richer picture of the main variables and their relationships in an organisation context. Detailed causal-loop analysis focuses on the organisation's recruitment, and staff development policy. Adopting the Inventory and Order-Based Production Control System (IOBPCS) model, a SKPM is developed to help understand the dynamics of skill acquisition and retention, particularly during times when an organisation is going through major changes. A PSKPM has shown the significance of the process pipeline policy to improving staff training and the retention rate. By adding a feed-forward path to the PSKPM, an APSKPM shows how new skills can improve the organisation productivity and contribute to the development of new products. The model responds to the training and learning needs as a result of present skill loss rate (feed-forward) as well as skill level and training performance (feedback). The research concludes by identifying learning barriers, describing how knowledge can be created and managed, and analysing how information and knowledge are disseminated over time.

The research has demonstrated the benefits of applying system dynamics in the field of organisational learning. The visual form of the models and the simulation outputs promotes understanding of the problems of retaining and developing the skills base, and the effects of speeding up the learning process within an organisation. The research shows that system thinking tools (such as causal-loop) and system dynamics can provide a greater insight for organisations set to embark on a learning organisation journey.

PREFACE

The following thesis is submitted in partial fulfilment of the requirements of the Sheffield Hallam University for the degree of Doctor of Philosophy entitled “AN ANALYSIS OF TQM AND ORGANISATIONAL LEARNING PROCESSES USING MODELLING AND SIMULATION”.

The overall aim of this research work is to construct a conceptual framework of learning organisation to examine the relationship between the Total Quality Management (TQM) and Organisational Learning (OL), and develop dynamic simulation models of the learning process/loops, via system dynamics.

Overview of the thesis

The thesis is structured into eight distinct but interrelated Chapters. What will be found throughout the Chapters is an attempt to marry theory to practice but overall the study represents a thorough analysis of the TQM and organisational learning. The main deliverables from these Chapters are developing the learning organisation conceptual framework, the validation of the framework through implementation in practice, and a family of system dynamic models are developed for anticipating skill gaps to design recruitment and training policies. The Chapters include: -

Chapter one: introduces the three waves of quality. The mutual dependence of total quality management and organisational learning and the purpose of the organisation transformation are described. The significances of learning process evaluation to organisational learning are explained. The main objectives of the research are outlined and methodology proposed which is used for simulation analysis.

Chapter two: provides an assessment of the meaning of quality and total quality management. A literature review is undertaken to establish whether a generic definition of quality exists. Furthermore, two types of the quality award models, the Malcolm Baldrige National Quality Award (MBNQA) and the European Foundation for Quality Management (EFQM), are presented and discussed. Chapter two concludes by

identifying the gaps and weakness in the total quality management implementation.

Chapter three: conducts a detailed literature review of learning and organisational learning. The difference between organisational learning and learning organisation is illustrated. This Chapter differentiate between the different levels of learning, and takes into account different organisational learning types. Also, organisational learning processes and creating learning organisation are presented. The link between individual learning and organisational learning is discussed. This Chapter concludes by describing the way forward for the learning organisation.

Chapter four: offers a historical account of the evolution of TQM. It has identified eighteen essential factors contributed to total quality management. The relationships between TQM and organisational learning are developed. The most significant linkage is that of combining systems thinking and total quality management. The main deliverable of this Chapter is the conceptual framework for the learning organisation. The framework consists of twenty-eight elements, which are categorized under Technologies and tools (T), Organisation and system (O), and People (P). Nineteen endogenous dependent outcomes have also been identified and grouped under, non-financial and financial performance categories. These elements are enlists, and a description of each factor/variable and potential relationships are provided.

Chapter five: provides a questionnaire survey, which is used to evaluate the conceptual framework for both manufacturing and non-manufacturing organisations. Through analysis of the collected data, some important research findings are summarized and presented. The results of the survey are also used to validate the effectiveness of the framework. Of the 26 organisations considered in detail, only four organisations were found to be in the third wave of quality. Thirteen organisations were found to be in the second wave of quality. Nine organisations had not yet embarked on a journey to become a learning organisation.

Chapter six: discusses the major causal relationships presented in the causal-loop model for the three learning waves. The Skill Pool Model (SKPM) has been used as a datum for the dynamic analysis. Computer simulation was used to find the criteria values for the step input responses of combinations of parameter values for SKPM. This Chapter presents and simulates SKPM, capturing the key elements of skill staff to help understanding the dynamic of skill acquisition and retention, particularly during times when an organisation is going through major changes.

Chapter seven: improves the dynamic behaviour of the Skill Pool Model by adding an extra feedback term. However, for a step change in present skill loss rate this introduces a final value offset in the actual skill level. It is shown how the addition of an extra feed-forward path to PSKPM, representing the pipeline skills in process target value, eliminates the actual level of skill pool offset problem.

Chapter eight: contains a brief summary and contribution to total quality management, organisational learning and system dynamics. Implication for further work on the framework and the dynamic simulation models are discussed.

ACKNOWLEDGEMENTS

I would like to record my appreciation and gratitude to a group of people for their guidance and help provided throughout the duration of this research.

- To Egyptian Higher Minster of Education (Egyptian Cultural and Educational Bureau – London) for providing financial support.
- To Dr. Khalid Hafeez (my Director of Studies) for his guidance, support, friendship, and long commitment in completing this work.
- To Professor Edmund K. Lo (my former Director of Studies) for his guidance and help to bring this to fruition.
- To Professor Terrence Perera (my Supervisor) for his help whenever it was needed.
- To Dr. Mike Hubbard for his guidance and help provided to make the amendments and corrections after the oral examination.
- To my colleagues in the Manufacturing Engineering Research Group who have provided invaluable help on many aspects of the thesis. In particular, I express my appreciation to Mr. Jurgen Hemme for many valuable discussions.
- To my wife and daughters, who have joined with me during my stay in an alien culture and sacrificed many days and nights of family union and social time to support my research work. My sincere thanks are due to my family, especially my mother for her continuing prayers.

To all these, I dedicate this thesis, with the hope that it is worthy of their attention.

LIST OF FIGURES

Chapter 2

Figure 2.1: A summary of quality definitions.....	10
Figure 2.2: Dynamic relationships among the seven categories	16
Figure 2.3: European Foundations for Quality Management	17

Chapter 3

Figure 3.1: Organisation learning levels.....	31
Figure 3.2: Senge's five key disciplines	35

Chapter 4

Figure 4.1: Evolution of quality.....	48
Figure 4.2: Correlation between total quality and organisational learning (Learning Flywheel).	54
Figure 4.3: Evolution of learning organisation	56
Figure 4.4: The conceptual framework for a learning organisation	57

Chapter 5

Figure 5.1: Respondents by industry/sector.....	68
Figure 5.2: Implementation period profile of the respondent organisations.....	69
Figure 5.3: The continuous improvement strategy profile of the respondent organisations	69
Figure 5.4: Employee profile of the respondent organisations.....	69
Figure 5.5: Sales profile of the respondent organisations.....	70
Figure 5.6: A comparison of self-perception against framework analysis	71
Figure 5.7: The values of enablers for the first wave case study.....	74
Figure 5.8: The average values of T, O, and P (enablers) for the first wave case study	75
Figure 5.9: The values of organisational performance (results) for the first wave case study.....	75
Figure 5.10: The average values of financial and non-financial performance for the first wave case study	76
Figure 5.11: The average values of T, O, and P (enablers) and organisational performance (results) for the first wave organisations	77

Figure 5.12: The average values of the enablers for the first wave organisations.....	79
Figure 5.13: The average values of organisational performance for the first wave organisations	80
Figure 5.14: The values of enablers for the second wave case study	81
Figure 5.15: The average values of T, O, and P (enablers) for the second wave case study.....	82
Figure 5.16: The values of organisational performance (results) for the second wave case study	82
Figure 5.17: The average values of financial and non-financial performance for the second wave case study	83
Figure 5.18: The average values of T, O, and P (enablers) and organisational performance (results) for the second wave organisations.....	84
Figure 5.19: The average values of enablers for the second wave organisations	87
Figure 5.20: The average values of organisational performance for the second wave organisations	88
Figure 5.21: The values of enablers for the third wave case study.....	89
Figure 5.22: The average values of T, O, and P (enablers) for the third wave case study	90
Figure 5.23: The values of organisational performance (results) for the third wave case study	90
Figure 5.24: The average values of financial and non-financial performance for the third wave case study	91
Figure 5.25: The values of T, O, and P (enablers) and organisational performance (results) for the third wave organisations	92
Figure 5.26: The average values of enablers for the third wave organisations	93
Figure 5.27: The average values of organisational performance for the third wave organisations	93
Figure 5.28: Average score of the twenty-six sample organisations according to T, O, and P classifications	96
Figure 5.29: Correlation between the T, O, and P enablers for the twenty-six sample organisations	97
Figure 5.30: The overall financial and non-financial performance scores for the twenty-six sample organisations	98
Figure 5.31: Performance matrix for the twenty-six sample organisations	99

Chapter 6

Figure 6.1: Influence diagram of the three quality waves.	106
Figure 6.2: A causal-loop diagram of skill and quality improvement	108
Figure 6.3: Causal-loop diagram of skill level	108
Figure 6.4: Causal-loop diagram of skill level with skill gap correction.	109
Figure 6.5: Causal-loop diagram for skill loss rate.....	110
Figure 6.6: Causal-loop diagram representing first wave of quality.	111
Figure 6.7: Causal-loop diagram illustrating the relationship between knowledge and new ideas	112
Figure 6.8: Causal-loop diagram representing knowledge and learning relationships.....	112
Figure 6.9: Causal-loop diagram representing flow of knowledge within organisation.	113
Figure 6.10: Causal-loop diagram representing knowledge acquisition and erosion	113
Figure 6.11: Causal-loop diagram of second wave of quality	114
Figure 6.12: Causal-loop diagram representing the learning and training relationships.	115
Figure 6.13: Causal-loop diagram representing knowledge/skill development relationships.....	115
Figure 6.14: The effect of competence gap on competence pool	116
Figure 6.15: Causal-loop diagram of competence pool with the effect of the present competence loss	117
Figure 6.16: Causal-loop diagram representing the third wave of quality	118
Figure 6.17: Influence diagram of SKPM.	120
Figure 6.18: A block diagram representation of SKPM.	121
Figure 6.19: Skill level measurements.....	125
Figure 6.20: Training completion rate measurement.....	126
Figure 6.21: Step response of SKPM for varying values of T_i	129
Figure 6.22: Step response of SKPM for varying values of T_a	130
Figure 6.23: Step response of SKPM for varying values of T_p	132

Chapter 7

Figure 7.1: Influence diagram of PSKPM.	139
Figure 7.2: A block diagram representation of PSKPM.....	140

Figure 7.3: Measurement of skill in process criteria.	142
Figure 7.4: Step response of PSKPM for varying values of T_i	145
Figure 7.5: Step response of PSKPM for varying values of T_a	148
Figure 7.6: Step response of PSKPM for varying values of T_w	150
Figure 7.7: Step response of PSKPM for varying values of T_p	153
Figure 7.8: Influence diagram of APSKPM	156
Figure 7.9: A block diagram representation of APSKPM.....	157
Figure 7.10: Step response of APSKPM for varying values of T_i	160
Figure 7.11: Step response of APSKPM for varying values of T_a	163
Figure 7.12: Step response of APSKPM for varying values of T_w	166
Figure 7.13: Step response of APSKPM for varying values of T_c	168
Figure 7.14: Step response of APSKPM for varying values of T_p	172
Figure 7.15: Step response of SKPM, PSKPM, and APSKPM at the optimum design values	175

LIST OF TABLES

Chapter 4

Table 4.1: Comparative study of ten Guru's showing emphasis on various TQM elements.	50
Table 4.2: Comparative study of ten Gurus' showing emphasis on various learning organisation elements	52

Chapter 5

Table 5.1: The correlation between the conceptual framework elements and the relevant questions presented in the questionnaire.....	67
Table 5.2: Correlation between the framework elements and the relevant elements presented analysis	72
Table 5.3: The overall profile and results of the twenty-six sample organisations	100

Chapter 6

Table 6.1: Definitions of learning, knowledge, skill and competence.....	107
Table 6.2: Summary the effect of T_i , T_a , and T_p on the measurement of performance indices.....	134

Chapter 7

Table 7.1: Summary the effect of the optimum design parameters and corresponding performance indices.....	177
---	-----

NOMENCLATURE

ALSKP	Actual level of skill pool
APSKPM	Automatic Pipeline Skill Pool Model
DLSKP	Desired level of skill pool
DSKIP	Desired skills in process
FSKLR	Forecast skill loss rate
PSKLR	Present skills loss rate
PSKPM	Pipeline Skill Pool Model
SKG	Skill gap
SKIP	Skills in process
SKIPA	Skills in process adjustment
SKPM	Skill Pool Model
S	Laplace operator
TCRATE	Training completion rate
TRATE	Training rate
T_i	Recovery time
T_p	Pipe-line lead-time
T_a	Demand average time
T_w	Time to adjust skills in process correction rate
T_c	Estimated pipeline lead-time
ζ	Damping ratio

CHAPTER 1

INTRODUCTION

1.1 Introduction

Since the early 1940's, that is about twenty years after the advent of first production line, studies have revealed that appropriate training and job satisfaction helps to create a productive and effective workforce giving organisations a competitive edge. Results from many recent studies show that in order to improve the working conditions, organisations should adopt a different approach from the Taylorist traditional style of management where workers are seen as cogs, i.e. part of a process towards an end product. They are given little opportunity to take part in any decision-making concerning how to increase the overall productivity of the organisation or how to improve their own working conditions. During the past 50 years, at least within the developed areas of the world, things have moved a long way forward.

This Chapter discusses the significance of the mutual dependence of total quality management and organisational learning through a brief introduction of the concept of the three waves of quality. Also, the significances of learning processes evaluation to organisational learning are explained and the organisation transformation are described. This Chapter presents the research aims and objectives and proposes the research methodologies are used for constructing and developing the conceptual framework and simulation analysis.

1.2 The research background

Recently, increasing efforts have been made to improve the working practices of organisations. These efforts can be described as the three waves of quality (Senge, 1994a). The first wave encompasses TQM elements such as a renewed focus on customers, greater employee involvement and an emphasis on continuous improvement. The second wave of quality concerns the process of designing the work fostering new ways of thinking and interacting conducive to continual learning across the system-wide performance. The third wave involves the institutionalisation of learning.

The purpose of the organisational transformation is to enable the organisation to search for new ideas, new products, and new opportunities for learning from which competitive advantage can be culled in an increasingly competitive world. In other words, organisations must be able to learn and to learn from their learning. Without this ability organisations will not be able to exercise appropriate choice in respect of structure, process, culture, product and, sooner or later, they will fail. A learning organisation cannot be defined in terms of specific structures or cultures, or in terms of normative models of good practice. Processes and values are central. A learning organisation works to create values, practices and procedures in which learning and working are synonymous throughout the organisation. Learning and the learning organisation are frequently mentioned as conducive to successful change. The main characteristics of a learning organisation is how to institutionalise the continual learning process such that it should be manifested in the underlying procedures, practices, code of conducts, routines and even in the products. A learning organisation is defined as “an organisation skilled at creating, acquiring, and transferring knowledge, and modifying its behaviour to reflect new knowledge and insights” (Garvin, 1993). Senge (1994b) describes learning organisation as “a place where people continually expand their capacity to create results they truly desire, where new and expansive patterns of thinking are nurtured, where collective aspiration is set free and where people are continually learning how to learn”.

A learning organisation often seeks to create its own future. It assumes learning is an ongoing and creative process for its members, and it develops, adapts and transforms itself in response to the needs and aspirations of people, both inside and outside itself (Pedler, 1989). Through learning, organisations adapt to change, avoid the repetition of past mistakes, and retain critical knowledge that would otherwise be lost. The amount of learning takes place within an organisation would eventually prove to be a critical factor for its survival and success. In broad terms, a learning organisation can be viewed as a social system whose members have learned conscious, communal processes for continually; generating, retaining and leveraging individual and collective learning to improve the performance of the organisational system in ways important to all stakeholders; and monitoring and improving performance (Drew and Smith, 1995).

The idea of a hierarchical ordering or levels of learning is popular within the learning organisation literature. The idea is described in different ways by several authors:

Argyris and Schon's (1981) notion of single-loop and double-loop learning is perhaps most commonly cited, however, other variations include first-order and second-order learning (Bartunek and Reed, 1992; Watzawick *et al.*, 1974) Zero learning and Learning I, II, III and IV (Batestone, 1972; Palmer, 1979), habit formation learning, adaptive organisation learning and creative proactive learning (Burgoyne, 1995). Many commentators on the learning organisation tend to emphasise learning in the context of the organisation transforming itself in relation to its environment and a reciprocal process of individual learning and development.

A central issue, in the context of notions of the learning organisation is the nature of organisational knowledge. If organisational learning is defined as the development of new knowledge or insights that has potential to influence behaviour (Huber, 1991; Sinkula, 1994), what is knowledge and how does it develop as well as what are the conditions for knowledge to develop? These issues have received limited attention in the learning organisational literature. Huber (1991) thinks that learning occurs in an organisation "if through its processing of information the range of its potential behaviours is changed". He considers the following four constructs as integrally linked to organisational learning: knowledge acquisition, information distribution, information interpretation, and organisational memory. He believes that learning need not be conscious or intentional and learning does not always increase the learner's effectiveness or even potential effectiveness. Moreover, learning need not result in observable changes in behaviour.

A learning organisation should be an organisation skilled at creating, acquiring and transforming knowledge, and at reforming the behaviour patterns of decision makers to reflect new knowledge and insights so as to evaluate total quality management in every process. Organisations failing to grasp the basic truth that TQM requires a commitment to learning is the reason why failed programmes far outnumber successes, and success rates remain distressingly low. For TQM to succeed and to achieve the objectives the entire workforce must acquire new knowledge, skills and abilities.

In Europe some organisations are understood to be in the first wave of quality where front-line workers are given training and development opportunities recognising the importance of their contributions within the organisation. In contrast in Japan most of

the organisations are now in the second wave of quality. Japanese managers have been given the training to hold regular quality circles with the aim of educating their workers how they all fit in the overall system and objectives of their organisation.

The main concern for learning organisation in this study is to develop a conceptual linkage of TQM and organisational learning to improve organisational and people performance and to speed up, the learning processes within an organisation. By discussing the evolution steps of quality movement, this research is to develop and analyse the building blocks of a learning organisation. System dynamics modelling is used to develop a family of conceptual learning models, which describes the relationships and influences between total quality management and organisational learning.

1.3 Research objectives

The overall aim of this research work is: -

1. To identify the characteristics of TQM and organisational learning.
2. To construct the conceptual relationships between TQM and organisational learning.
3. To develop learning organisation framework to evaluate organisational learning practices in the European organisations.
4. To introduce system thinking and causal-loop models for the TQM and organisational learning practices.
5. To introduce system dynamic simulation analysis for modelling learning processes as an aid for human resource policy decisions.

1.4 Research methodology

The methodology of this research adopts four main features: literature review, develop a conceptual framework, validation of the conceptual framework through a questionnaire survey, and to provide a dynamic simulation model.

1.4.1 Literature review

The literature survey is used to identify essential factors that contribute to TQM and learning organisation. They can be generally classified accordingly to technology and tools, organisation and systems, and people. Also this indicates the importance of each

of these elements broadly based on the work of at least 20 well-known authors in this field. The other objective is to study and review the relationships between the total quality management and the organisational learning.

1.4.2 EFQM model and operations management

The enablers-results mechanism of European Foundation for Quality Management (EFQM) (EFQM, 1999) is adapted to construct the learning organisation framework. Also these enablers and results are grouped and evaluated under the standards operations management framework of Technologies and tools (T), Organisation and system (O), and People (P).

1.4.3 Questionnaire survey

The questionnaire survey is used to evaluate the conceptual framework for both manufacturing and non-manufacturing organisations. Through analysis of the collected data, some important research findings are summarised and presented. Data from the questionnaire survey is used to validate the three waves of quality.

1.4.4 System thinking and system dynamics

System thinking is used to develop causal-loops (influence diagrams) for the three waves of quality. Causal-loop diagrams display all the major influences and feedback loops that exist between variables; they provide a qualitative portrayal of the feedback structure of the system. Simulation models are developed to analyse the time-based learning behaviour of an organisation using a system dynamics modelling process. System dynamics is defined as a modelling and simulation methodology used to study the complex dynamics of large, non-linear managerial, socio-economic, human systems (Richardson, 1981). Computer simulation is therefore used to analyse the behaviour of such complex dynamic models. Various software packages exist for system dynamics modelling; in this case, the *ithink* software is used.

1.5 Summary

By introducing the three waves of quality to illustrate the evolution steps of learning organisation, the basic concept of learning organisation is discussed and summarised. After defining the research aims and objectives of this study, a research methodology is

provided. The methodology of this research adopts four main features, literature review, EFQM model and operation management, questionnaire survey, and system thinking and system dynamics.

The literature review has identified essential elements contributed to TQM and learning organisation, to indicate the importance of each of these elements and to study and review the relationships between the total quality management and the organisational learning. EFQM is used to construct the learning organisation framework. To evaluate the conceptual framework for both manufacturing and non-manufacturing organisations the questionnaire survey is developed. System thinking is used to develop causal-loops (influence diagrams) for the three waves of quality. System dynamics is used to develop a simulation model analyse the time-based learning behaviour of an organisation. An overview and more details of these research methodologies are presented in the following Chapters.

1.6 References

- Argyris, C. and Schon, D.A. (1981), "Organisational Learning", Addison-Wesley, Reading, MA
- Bartunek, T.M. and Reed, R.D. (1992), "The role of conflict in a second order change attempt", in Kolb, D.B. and Bartunek, T.M. (Eds), *Hidden Conflict in Organisations*, Sage, London.
- Batestone, G. (1972), "Steps to an Ecology of the Mind", Ballantine, New York, NY
- Burgoyne, J.G. (1995), "Feeding minds to grow the business", *People Management*, 21 September
- Drew, S. and Smith, P. (1995), "The learning organisation: change proofing and strategy", *The Learning Organisation*, Vol. 2 No. 1, pp. 4-14.
- EFQM, (1999), "The EFQM Excellence Model", Public and Voluntary Sector, The European Foundation for Quality Management, Brussels
- Garvin, D.A. (1993), "Building a learning organisation", *Harvard Business Review*, Vol. 71, July/August, pp. 78-91.
- Huber, G.P. (1991) "Organisational learning: the contributing processes and the literatures", *Organisation Science*, Vol. 2, February, pp. 88-115.
- Palmer, B. (1979), "Learning and the group experience", in Lawrence, W.G. (Ed.), *Exploring Individual and Organisational Boundaries*, John Wiley, Chichester.

- Pedler, M., Boydell, T. and Burgoyne, J., (1989), "Towards the learning company",
Management Education and Development, Vol. 20 Part 1
- Richardson G.P. and A.L. Pugh, (1981), "Introduction to system dynamics modelling
with DYNAMO", MIT Press, Cambridge, MA
- Senge, Peter, M., (1994a), "Building learning organisations", H. Costin, editor, Reading
in Total Quality Management (Fort Worth. TX: The Dryden press), pp. 60-67.
- Senge, Peter, M., (1994b), "The Fifth Discipline: The Art and Practice of the Learning
Organisation", Doubleday New, York.
- Sinkula, F.M. (1994), "Market information processing and organisational learning",
Journal of Marketing, Vol. 58, January, pp. 35-65.
- Watzawick, P., Weakland, T.H. and Fisch, R. (1974), "Change: Principles of Problem
Formation and Problem Resolution", W.W. Norton, London.

CHAPTER 2

LITERATURE REVIEW: PART I

TOTAL QUALITY MANAGEMENT

2.1 Introduction

The three waves of quality have been highlighted as a critical movement from total quality management to organisational learning in Chapter 1. The purpose of this Chapter is to present an overview of the literature on total quality management (TQM). The literature review gives an appropriate framing for the matters discussed in this thesis.

The overview in this Chapter covers the fundamentals of total quality management with special emphasis on what are described as the essentials of TQM. It is presented in six parts. The first part provides an assessment of the meaning of quality. The second part looks at the definitions and the characteristics on of the TQM. The third and fourth parts review the TQM philosophies by studying the work of ten quality Gurus' to underpin the fundamental factors and mechanisms of TQM. The fifth part looks at two types of the quality award models, which are the Malcolm Baldrige National Quality Award (MBNQA) and the European Foundation for Quality Management (EFQM). The final part identifies the gaps and weakness in TQM to implemented successfully and concludes by synthesising the information in the literature into a coherent framework in an attempt to portray the key principles and components of TQM.

2.2 Quality definition

In organisations of every kind, quality can be regarded as a means to an end-customer satisfaction in all aspects of the product or service. Deming (1986) defines quality as control of variation “a predictable degree of uniformity and dependability at low cost and suited to the market. Juran (1988a) sees quality from internal customer perspectives and he defines quality as “fitness for purpose” but Juran doesn't state who is specifying the purpose and making the decision as to its fitness. A different definition was given by Crosby (1979) who defined quality as conformance to requirement not elegance. In 1992 Crosby broadened his definition for quality adding an integrated notion to it: “quality meaning getting everyone to do what they have agreed to do and to do it right the first

time is the skeletal structure of an organisation, finance is the nourishment, and relationships are the soul". However, the ISO 8402 (1986) offers an alternative systemic definition of quality, "the totality of features and characteristics of a product or service that bear on its ability to satisfy a given need".

For Garvin (1988) quality can be seen from three views: -

- User-based definition: - Quality is measured by the degree to which the wants and needs of customer are satisfied.
- Product-based definition: - quality refers to the amount of desired attributes contained in the product.
- Manufacturing-based definition: - Quality is measured by the percentage of scrap or rework required during the production process.

Garvin is of the view that these meaning can co-exist within an organisation. He goes on to suggest that it may become necessary to give quality a different meaning in different industries, and also probably change the approach taken towards quality from user-based to product based, as products move through market research to design; and then from product-based to manufacturing based, as they go from design into manufacture. However, the user-based definition is more appropriate in a service organisation because it denotes that those services, which meet customer preferences and expectations, are the central thrust of high quality.

Feigenbaum (1991) states, "quality is a customer determination, not an engineers determination, not a marketing determination, or a general management determination, it is based upon the customer's actual experience with the product or service measured against his or her requirements stated or unstated, conscious or merely sensed". Thus, product and service quality can be defined as: "the total composite product and service characteristics of marketing, engineering, manufacture and maintenance through which the product and service in use will meet the expectations of the customer".

However, TQM writers have failed to provide an adequate definition of quality that can be easily related to the philosophy of TQM. For example, Ishikawa (1990) state "Quality

management is a revolutionary management philosophy characterised by the quality strategic goals”. Taguchi defined quality, as “the quality of product is the minimum loss imparted by the product to the society from the time the product is shipped” (Taguchi, 1996). According to Oakland and Dotchin (1994) the most applicable definitions of quality are: fitness for use, the user perspective, and conformance to specifications (the manufacturing perspective). All are necessary for customer satisfaction.

Quality is meeting the customer requirements. Figure 2.1 gives a summary of what quality means. Quality defined from the viewpoint of different quality professionals and to provide a conceptual scheme for the discussion of TQM. This can be classified under three categories: customer-base, service and manufacturing-base, and value-based definition as shown in Appendix 2.1.



Figure 2.1: A summary of quality definitions

2.3 Total quality management

Total quality management is based on a number of ideas. It means thinking about quality in terms of all functions of the enterprise. In systems terms it implies thinking about the interaction between all the components of the organisation as well as the components themselves. TQM aims to achieve an overall effectiveness higher than the individual outputs from the sub-systems as design, planning, production, distribution, customer focus strategy, quality tools and employee involvement. Customer satisfaction and continuous improvement are the essential beliefs of the TQM philosophy. Therefore one can say that TQM is essentially about changing people’s attitudes about the jobs and functions they perform geared towards providing customer satisfaction.

In spite of the vast amount of work conducted, a literature review suggests that it is difficult to find a standard definition of TQM. This section conducted for this study aims to provide a few definitions for convenience that incorporates the key characteristics and framework of TQM. According to Oakland (1993) "TQM is an approach for improving the competitiveness, effectiveness, and flexibility of an organisation". Essentially it is a way of planning, organising and understanding activities and individuals at each level". For an organisation to be truly effective each part of it must work together towards the same goals, recognising that each person and each activity has a domino impact on the inter-related system. For Crosby (1979) quality management is a systematic way of guaranteeing that organised activities happen the way they are planned. It is a management discipline concerned with preventing problems from occurring by creating the attitudes and controls that make prevention possible. TQM advocates zero defects in the products and services produced by an organisation. It is about driving quality into all aspects of organisation's operation.

However, one major premise of TQM is the definition of quality by Juran (1988b) who describes it as "fitness for use" which may be seen a key to business success in the 1990's against the other established performance indices such as price and delivery. The aim is to have quality built-in rather than inspected-in by quality being the responsibility of all employees, rather than the exclusive presence of a specialist department. This is expected to minimise the overall cost because it brings about a decline in failure rates, warranty costs, returned goods, and reduction in the costs of detection. According to Juran TQM involves a primary focus on the requirements of the external as well as the internal customers within the organisation.

Ishikawa (1985) argues, "Quality management is a revolutionary philosophy characterised by the quality strategic goals those are focussed towards customers preferences, likes, tastes, and applications". He believes that organisational functions should recognise the internal supplier-customer relationships, as each related process being a customer. However, there are some who reject the idea of an internal customer, as there is a danger that it would take away the 'focus' from the end-customer. This is evidenced by Motorola, widely regarded as one of the quality success stories, and firmly rejects the internal customer approach arguing that there is only one customer; the person who pays the bills.

Kanji (1990) notes that the modern concept of quality is defined as conformance to requirements, and requirements are defined as the task to be accomplished in meeting customer needs. According to him quality is to satisfy customer's requirements continually, total quality is to achieve quality at low cost, and TQM is to obtain total quality by involving everyone's daily commitment.

In the present author's view, the essence of quality is do it right first time, and every time satisfy customer requirements by involving everyone in the organisation. TQM is therefore a philosophy of management that strives to make the best use of all available resources and opportunities by continuous improvement. TQM is the key business improvement strategy and the key management issue of the present as well as future because it is essential for improving efficiency and competitiveness.

2.4 TQM philosophies

Constructing a universal definition of TQM is impossible since definitions are affected by a particular managerial situation or problem. W. Edwards Deming, one of the most respected contributors to the quality management movement, claimed he never used the term TQM as it did not carry any meaning (Romano, 1994). Nevertheless, Deming's 14 points have generated the most impact on the TQM evolution and have been studied extensively (Tamimi *et al.*, 1995). Black and Porter (1996) examined the criteria for the Baldrige Award and the published TQM literature and subsequently identified ten critical factors of TQM. However, they have created considerable confusion when the theoretical aspects of TQM are discussed, or attempts to design and implement TQM programs are made. Harai (1993) believed this uncertainty of the nomenclature of TQM is a problem in and of itself; "given the fact that there is a multitude of definitions, theories and programs in the public domain, it is difficult to specify exactly what TQM is". This confusion is compounded by the proliferation of commercialised TQM training programs offered as a package with no attempt to differentiate between industries or organisations (Caudron, 1993). As a result, many different versions of TQM have been developed, delivered, studied and defended by different professionals (Harai, 1993).

The result is that many TQM initiatives have become so ill-defined that the term itself risks becoming a cliché, making it very difficult for many organisations to design and implement effective quality programs. Ultimately, many organisations have rejected

TQM as merely another management fad. However, it would be a mistake to reject TQM at this level, for several important implementation concepts arises directly out of the more general management philosophy perspective. Grant *et al.* (1994) addressed in detail the difference between TQM and conventional management techniques regarding the philosophies and theories that underlie them. For TQM benefits to be fully realised, managers in every level of an organisation need to prepare themselves for change. The philosophical dimension of TQM should also provide a focus for everyone in the organisation by specifying those things that are valued highly by customers, employees, and management.

2.5 TQM Gurus' principles

The literature review indicates that despite quality management being considered a matured field of study it is difficult to define the concepts of TQM. A study of the work associated with ten quality Gurus' (Deming, Juran, Crosby, Ishikawa, Mellor, Kanji, Shingo, Oakland, Feigenbaum and Taguchi) is conducted with the objective to compare and contrast their views, which underpin the fundamental factors and mechanisms of TQM.

Broadly speaking TQM refers to thinking about quality from the perspective of all functions within enterprise. In systems terms it implies thinking about the interaction between all the quality components of the organisation as well as within the components themselves (Oakland, 1993). TQM aims to achieve an overall effectiveness through integrating individual activities in design, planning, production, distribution and customer service (Oakland 1993). It is about changing the mindsets and attitudes of all those involved about the jobs and functions they perform geared towards providing customer satisfaction. TQM advocates zero defects in the products and services through the process of continuous improvement (Crosby, 1979). It is supported by, management by fact, continuous improvement, delight the customer and people based management (Kanji and Asher, 1993).

From the analysis, it could be argued that, the general message is essentially the same:

- Management commitment and employee awareness is essential in TQM. Personnel as all levels need to participate in the improvement process (Feigenbaum, 1991;

Crosby, 1979; Juran, 1993). Deming's (1986) 14 points provide an effective starting-point to encourage the necessary attributes.

- Juran (1988b) emphasises the need to plan and prioritise actions with the quality planning road map. Quality costing can be used to prioritise and monitor improvement, and to measure the progress of improvement. Service quality can be measured once qualitative and quantitative research has defined what matters to the customer.
- Teamwork plays an important part in the process of continuous improvement. Indeed, problem solving and improved communication is extremely difficult to achieve without it. Ishikawa (1985) advocated quality circles, which create greater worker involvement and motivation leading to greater commercial awareness and the aim for ever-increasing goals.
- If all employees are to be involved in the improvement process, then simple tools and techniques need to be taught (Crosby, 1989; Deming, 1986). All levels within an organisation can use Ishikawa's seven tools of quality control (Ishikawa, 1985).
- Taguchi (1996) provide more technical tools to control areas including industrial design and manufacturing. Taguchi's quality loss function includes the costs to the customer resulting from poor product performance and reliability.
- To achieve quality, management tools should be studied. Feigenbaum's concept of total quality control stresses the need for top-to-bottom commitment to quality (Feigenbaum, 1991). Ishikawa (1985) also promotes the concept of organisation-wide quality control.
- In today's competitive markets, "quality as perceived by the customer" has become a key aim for many organisations. Deming's message to "delight your customers" is seen by many as the way to be competitive in today's markets (Deming, 1986).

It is generally argued that a process, which exhibits such features, will lead to increased corporate competitiveness and profit by increasing customer demand.

2.6 Models of quality awards

There has been a quality management framework as part of the Deming Prize in Japan for over four decades. The Deming Prize was instituted in 1951 by the Japanese Union of Science and Engineering (JUSE) in recognition of Deming's contribution to the development of industrial quality control in Japan. The Deming Prize is for enterprises or divisions, which achieve the most distinctive improvement in performance through the implementation of organisation-wide quality control based on statistical quality control. The items, particulars, and further information of the Deming Prize can be obtained from the Secretariat of the Deming Prize Committee (Kanji and Asher, 1993). However, it was not until 1987, when the Malcolm Baldrige National Quality Award (MBNQA) was established, that senior managers in the west started looking at quality award criteria as guiding frameworks to plot the approach for effective TQM implementation

2.6.1 The Malcolm Baldrige National Quality Award

The Malcolm Baldrige National Quality Award (MBNQA) promotes three important characteristics, namely, awareness of quality to increase competitiveness, understanding the requirements for excellence in quality, and sharing the information and benefits derived from successful quality strategies that are employed by the organisations (NIST, 1994). It is offered to organisations in three categories, namely, manufacturing, service and small organisations (NIST, 1994). To win the award, organisation must demonstrate a high degree of quality awareness and commitment, together with evidence of quality results. Among the many benefits to an organisation, which applies for the award is the feedback on its quality efforts, which helps to assess the effectiveness of its implementation. It is claimed many organisations apply to take advantage of this benefit.

Furthermore, to help people to understand the Baldrige award criteria, the MBNQA framework expresses values and concepts in seven categories and four key elements as shown in Figure 2.2. Seven categories of criteria are included in evaluating the organisation's overall strategic and operational strategies employed in implementing quality improvement efforts.

As shown in the dynamic relationships among these criteria in Figure 2.2, the primary focus of the award is on customer focus and quality and operational results. As Reimann

(1989) stated, the award is not given for a specific product or service, nor is it an endorsement of an organisation's product or service. It is given to those organisations that have world-class systems for managing their people and processes. Each system must ensure continuous improvement in its product or service and provide a way of satisfying and responding to its customers.

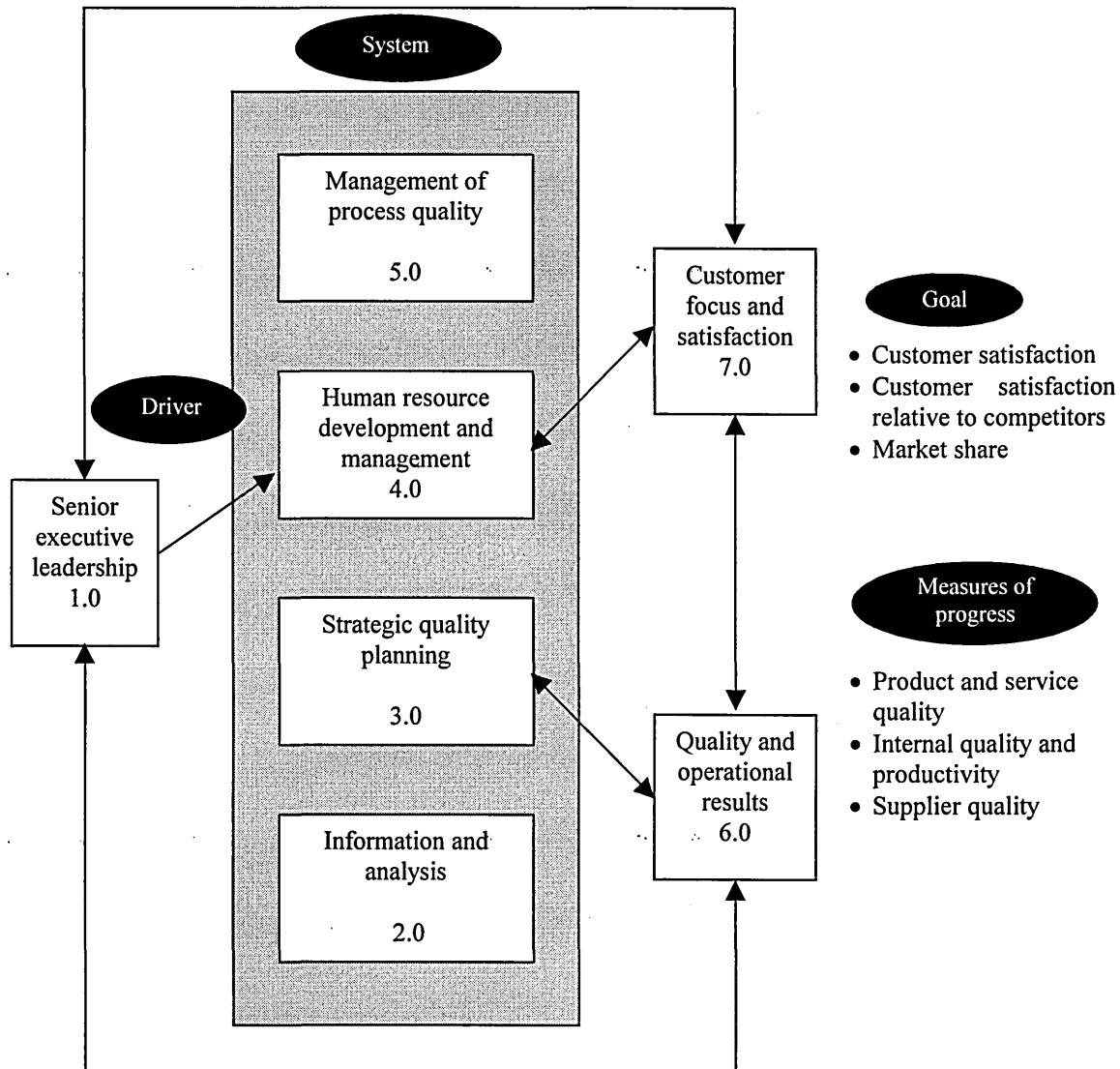

Figure 2.2: Dynamic relationships among the seven categories (NIST, 1994)

Furthermore, the MBNQA, as Garvin (1991) said, not only codifies the principles of quality management in clear and accessible language, but also provides organisations with a comprehensive framework for assessing their progress towards the new paradigm of management and such commonly acknowledged goals as customer satisfaction and increased employee involvement.

Since the introduction of MBNQA, several nations started their own award schemes for similar reasons to those linked to MBNQA. A notable one is the European Quality Award (EQA) established by the European Foundation for Quality Management in 1991.

2.6.2 The European Quality Award

The European Foundation for Quality Management (EFQM) established the European Quality Award (EQA) for the first time in 1992, mainly to accelerate the acceptance of quality as a strategy for global competitive advantage, to stimulate and assess the development of quality improvement activities, and to recognize the organisations in Western Europe that demonstrate excellence in the management of quality as their fundamental process for continuous improvement (EFQM, 1993). The EQA is also supported by the European Committee of the European Organization for Quality. This award consists of nine criteria for evaluation. Figure 2.3 illustrates the EQA framework. The nine elements of the framework, classified as either enablers or results, are seen as influencing one another.

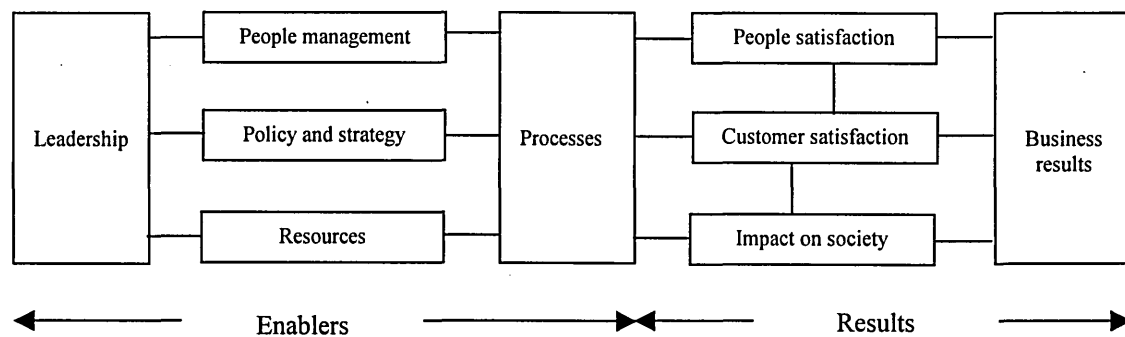

Figure 2.3: European Foundations for Quality Management (EFQM, 1999)

As can be seen from the Figure 2.3, the EQA criteria describe the processes and the people including the leadership, people management, policy and strategy, resources, and processes categories as the enablers that will accomplish the results which include customer satisfaction, people (employee) satisfaction, impact on society and business results.

The two models discussed above give greater attention to defining quality from customer's perspective and on the measurement of results. The EQA and the revised Baldrige criteria also extend the framework for quality to include public responsibility and corporate citizenship, and measurement of employee satisfaction (EFQM, 1993 and NITS, 1994).

It should be noted that the business results criterion includes financial measures such as profits, cash flows, productivity, market share, and quality cost. The MBNQA, on the other hand, does not include them in the quality and operational results criterion, as the award criteria do not cover the organization's financial performance.

In addition to the above, Tummala (1996) summaries the comparison between MBNQA and EFQM models which can conclude as the following: -

- Both the MBNQA and EQA are results oriented awards.
- Both awards give maximum weight to customer satisfaction results. Thus, customer focus and satisfaction is the overall goal of both the awards.
- The MBNQA criteria do not include financial performance whereas it is included in the EQA criteria.
- The EQA, by including the impact on society as one of the nine criteria, covers more aspects such as preservation of global resources in a more detailed fashion than the MBNQA.
- The MBNQA and EQA are neither product nor service excellence awards, nor are they corporate management excellence awards. Both are positioned between these two extremes.
- Because of the inclusion of financial performance in the criteria, the EQA is more broad-based than the MBNQA.

In summary, the EFQM model has merit as a business audit approach but does not prescribe what to do and how to do it, rather it provides a framework to enable

individual organizations to assess themselves and look for opportunities to improve their service.

2.7 Pitfalls of TQM

Even in restricting what TQM means to the work of the ten Gurus of quality, there are still important differences in philosophy, approaches, and methods among these. Total quality management can provide significant cost benefits by improving the use of materials, optimising people's time, reducing the cost of production and employing capital more effectively (Eskildson, 1994). Most organisations emphasise the need for quality, but few can articulate precisely what it is and few organisations have been able to consistently deliver it. The set of gaps/weaknesses in TQM as identified according to Barry (1993) are the following: -

- Consistent, committed support from the top is recognised as crucial for success with total quality management. TQM recognises that this sort of inconsistent behaviour from the top will at least seriously interfere with implementation. TQM itself, as usually practiced, has no methods for dealing with the executive inconsistencies. Argyris and Schon (1978) show that this sort of inconsistent behaviour is very common.
- TQM problem solving tools tend to be reductionist rather than systemic. In particular, TQM lacks both a framework and tools to understand circular causal-loops. System dynamics provides powerful tools for understanding and managing these dynamics. The basic system dynamics framework provides tools for both qualitative analysis and computer simulation of situations where circular causal-loops are important.
- TQM shows how to continuously improve an existing process. What about some totally new product or even a new business or a radical re-structuring of the existing business? TQM does not help the organisation to invent some new and more desirable future for itself.
- Continuous improvement is a cornerstone of TQM. Improvement of any manufacturing or service process may be usefully classified into three different categories as follows: -

- Marginal improvements involve changes (eliminating bottlenecks, increasing efficiency, finding a better technique) that leave the basic process untouched.
- Process improvements involve changes to the basic manufacturing or service process, for example, a new kind of machine or a new method for one step in the manufacturing process.
- New technology involves a fundamental rethinking of the given manufacturing or service process. This level of change involves essentially starting over with a new way of producing the given product or service.

Each of these levels of improvements is critically important for long-range success. TQM usually focuses on the first, can be helpful with the second, and offers little help for the third.

- The question of organisational design is important for TQM for a number of reasons. First, TQM emphasises the importance of all parts of the organisation working in harmony because quality for the customer depends on all parts of the business. Second, as process improvements are made or new technology adopted, organisational structures become outmoded. Finally, as customers or their preferences change, the organisational structure needs to adapt as well. TQM, however, is silent on the question of how to design an organisation.
- TQM is very clear about the need for all areas of the organisation to work together. For instant, one of the main competitive advantages that Japanese auto makers have achieved is in the area of concurrent engineering. By making engineering design teams that include everyone involved in the process from the very beginning, the time required to bring a new model to market has been cut dramatically. The next stage in this evolution is to integrate the data for all parts of the organisation so that everyone has instant, electronic access to all relevant data, no matter where it may originate within the organisation. This vision of the data-integrated corporation is usually termed computer-integrated manufacturing.

- TQM requires the ability to work together across horizontal and vertical boundaries within the corporation. Unfortunately, many corporations are fraught with dissension and internal conflict. TQM is silent on the question of how to achieve collaboration among divisions and commonality of purpose between managers and workers.

In order to prevent failure in the TQM implementation Liberatore (1993) argues that corporate culture must change in order for new ways of thinking and doing business to evolve. TQM fails because, in most organisations, the culture is so ingrained, it resists change and attempting to change the established culture will not work unless it is disabled.

However, Chattergee and Yilmaz (1993) attribute the pitfalls encountered in the implementation of TQM to what they term the contradictory models of implementation devised by the Gurus i.e. Deming, Juran and Crosby. Whilst Juran advocates setting quality objectives and managing the quality plan according to those objectives, Deming is strongly opposed to management by objectives, as this will as to the use of merit ratings and slogans to achieve objectives. Crosby recommends zero defects as a quality objective, whilst Juran and Deming are against it because they argue that the inherent variability in all processes renders such an objective unrealistic. These assertions by the Gurus, argue Chattergee and Yilmaz, have created a quality jungle, because managers are obliged to interpret and implement the Gurus ideas as they see fit. Therefore, the bad name TQM is receiving is a matter of execution, but intent (Goodman, 1994).

The challenge of TQM, like any other organisational programme, is to assure that its full systemic outcomes are achieved. Its effects on the organisation at large, organisational stakeholders, and the organisational context are considered. The implementation and application of TQM must fit with participating organisations policies and procedures (the way work is supposed to be done) and with the organisations' culture (the way works actually accomplished).

TQM is not simply a means of quantifying quality; it is a means of expanding organisational thinking and learning capabilities. In the past, the essence of quality was to make products or deliver services according to fixed organisational standards.

2.8 Summary

The literature review of the TQM field shows that none of the quality Guru's definitions address the management of quality, which encompasses the optimisation of processes that occur within the organisation and beyond. On the other hand the various definitions of TQM in the literature, rely on the hard aspects of quality (production/operations aspects, measurement and control of work.) i.e. tools and techniques, without reference to organisational design and human issues. TQM can be superimposed on existing organisational structures with minimum attention paid to wider issues of organisational structure, worker dignity, process improvement, communication, culture and organisational politics.

TQM embodies a management approach that is committed to satisfying customers by designing, producing, and delivering high quality products. TQM attempts to involve all employees to continuously improve the organisation. TQM is an all-encompassing philosophy about managing a business. Total quality management is concerned with changing attitudes, skills and processes, so that the culture of the organisation becomes one of preventing failure – doing the right things, right first time, every time (Irani and Sharp, 1997). TQM is not just about improving production steps and reducing cycle times, however. It is a thought revolution in management (Ishikawa, 1985).

Two important conclusions are drawn from the TQM literature review. First is that TQM is about changing the mental models of management in order to enhance an organisation's fundamental capability to determine its own future. This change requires more than a one-time shift in thinking; it means continually re-evaluating the way managers think. Sustaining this thought revolution requires not only engaging in the continual improvement activities already accepted by many organisations, but also changing the conventional wisdom and mental models shared within an organisation.

The second conclusion is that for TQM to succeed, management commitment to learning and acquiring new knowledge and skills are required. As Garvin (1993) states "continuous improvement requires a commitment to learning. How after all can an organisation improve without first learning something new?" In other words, the success of TQM is related to an organization's ability to learn, to absorb, to adapt and to apply conceptual changes and integrate them throughout the organization. So, individual,

team, and organizational learning are the subject of discussions in order to test the mutual dependence existing between continuous improvement and continual learning. An overview of this body of the literature is presented in the next Chapter.

2.9 References

- Argyris, C., and Schon, D. A., (1978), "Organisational leaning: A theory of action perspective." Addison Wesley, Reading
- Barry C., (1993), "Total quality management and comprehensive change", Engineering Management Journal, Vol. 5, No. 1, pp. 6-10.
- Black, S.A. and Porter, L.J., (1996), "Identification of the critical factors of TQM", Decision Sciences, Vol. 27 No. 1, pp. 1-21
- Caudron, S., (1993), "Keys to starting a TQM program", Personnel Journal, Vol. 72 No. 2, pp. 28-34
- Chattergee, S. and Yilmaz, M., (1993), "Quality confusion: Too many Gurus, not enough disciples", Business horizons, May-June.
- Crosby, P., (1979), "Quality is free", Mc Graw - Hill, New York
- Crosby, P., (1989), "Let's Talk Quality: 96 Questions that you always wanted to ask Phil Crosby", McGraw-Hill, New York, NY.
- Deming, E., (1986), "Out of the crisis", Cambridge, Massachusetts
- Dotchin, J. A. and Oakland, J. S., (1994), "Theories and Concepts in Total Quality Management", Total Quality Management, Vol. 3, No. 2, pp. 133 -144
- EFQM, (1993), Total Quality Management The European Model for Self-appraisal, The European Foundation for Quality Management (EFQM), Brussels
- EFQM, (1999), "The EFQM Excellence Model", Public and Voluntary Sector, The European Foundation for Quality Management, Brussels
- Eskildson, L., (1994), "Improving the odds of TQM's success", Quality Progress, April
- Feigenbaum, (1991), "Total Quality Control (3rd edition)", Mc Graw-Hill, New York
- Garvin, D. H., (1988), "Managing Quality: The Strategic and Competitive Edge", New York, The Free Press.
- Garvin, D. A., (1993), "Building a learning organisation", Harvard Business Review, July – August, 71, pp.78-91.
- Garvin, D. A., (1991), "How the Baldrige Award really works", Harvard Business Review, November-December, pp. 80-95.

- Goodman, J. A., Bargatze, G. F. and Grimm, C., (1994), "The key problem with TQM", Quality progress, January
- Grant, R.M., Shani, R., and Krishnan, R., (1994), "TQM's challenge to management theory and practice", Sloan Management Review, Vol. 35 No. 2, pp. 25-35
- Harai, O., (1993), "The eleventh reason why TQM doesn't work", Management Review, Vol. 82 No. 5, pp. 31-6
- Irani, Z. and Sharp, J.M., (1997), "Integrating continuous improvement and innovation into a corporate culture: a case study", The International Journal of Technological Innovation and Entrepreneurship (Technovation), Vol. 17 No. 4, pp. 199-206.
- Ishikawa K., (1985), "What is Quality Control ? ", Prentice Hall.
- Ishikawa K., (1990), "Introduction to Quality Control", London, Chapman and Hall.
- ISO 8402, (1986), "Quality Vocabulary, International Standard Organisation", Geneva
- Juran J. M., (1988a), "Juran on Planning for Quality", New York, The Free Press
- Juran J. M., (1988b), "Quality Control Hand book", Mc Graw - Hill
- Juran, J.M., (1993), "Made in USA: a renaissance in quality", Harvard Business Review, Vol. 71 No. 4, pp. 42-50.
- Kanji, G., (1990), " Total Quality Management, The second Industrial Revolution", Total Quality Management, Vol. 1, No. 1, pp. 3-21.
- Kanji, G. and Asher (1993), "Total quality management process: a systematic approach", Journal of Total Quality Management, Vol. 4, Supplement.
- Liberatore, R. L., (1993), "The culture factor and quality", Quality progress, December
- Mellor C., (1987), "Personal quality", TMIALS
- NIST, (1994), The Malcolm Baldrige National Quality Award, US Department of Commerce, Technology Administration, Gaithersburg, MD.
- Oakland, J, S., (1993), "Total quality management - The route to improving performance", Butterworth - Heinemann.
- Reimann, C.W., "The Baldrige Award: leading the way in quality initiatives", Quality Progress, July 1989, pp. 35-9.
- Romano, C., (1994), "Report card on TQM", Management Review, Vol. 83 No. 1, pp. 22-5
- Taguchi, (1996), "The Taguchi approach to parameter design", ASQC quality congress transaction, Anaheim

Tamimi, N., Gershon, M. and Currall, S.C., (1995), "Assessing the psychometric properties of Deming's 14 principles", *Quality Management Journal*, Vol. 2 No. 3, pp. 38-52

Tummala V.M., Tang C.L., (1996), "Strategic quality management, Malcolm Baldrige and European Quality Awards and ISO 9000 certification, core concepts and comparative analysis", *International Journal of Quality and Reliability Management*, Vol. 13, No. 4, pp. 8-38.

CHAPTER 3

LITERATURE REVIEW: PART II

LEARNING ORGANISATION

3.1 Introduction

Recent literature argues that the 1990s and beyond will be a period of major change of organisations and business improvement. The emphasis is to constantly identify learning opportunities for individuals and the organisation (as a collection of individuals), share the learning from these and continuously transform the organisation.

In order to contextualise the work reported in this Chapter, it is useful to break down and understand the meaning of learning, learning organisation, and organisational learning as described in the earlier section. To identify the conceptual elements and understanding the learning organisation, this Chapter must address the link between the organisational learning and learning organisation, differentiate between the different levels of learning, and takes into account different organisational learning types. Also, organisational learning processes and creating learning organisation are presented in sections 3.8 and 3.9 respectively.

Organisations are comprised of individuals and must ultimately learn via their individual members. Hence, theories of individual learning are crucial for understanding organisational learning. The purpose of section 3.10 is to discuss a theory about the process through which individual learning advances organisational learning. Also, models of organisational learning are developed in some detail in section 3.11.

This Chapter concludes by describing the way forward of the learning organisation which presented in the later section. In abroad context, the purpose of this Chapter is to contribute towards building a theory to develop a learning organisation. Once this transfer process is clear understanding, the learning process can be consistent with an organisation's goals, vision, and values.

3.2 Learning

A dictionary definition of the word learning as a noun is “knowledge gained by study; instruction or scholarship, and the act of gaining knowledge” (McLeod, 1982). This implies a rather isolated, mechanistic view of a process, which is essentially integrated and iterative. Fiol and Lyles (1985) define learning as “the process of improving actions through better knowledge and understanding”. Learning itself includes three different activities: thinking, communicating and co-operating. When the organisation capacities to think, communicate and co-operate are enhanced, so is the organisation ability to learn (Fiol and Lyles, 1985).

Learning is as much a task as the production and delivery of goods and services. This doesn't imply that organisations should sacrifice the speed and quality of production in order to learn, but rather, that production systems be viewed as learning systems. While organisations do not usually regard learning as a function of production, learning becomes more integrated into how we work, where does “work” end and “learning” begin? (Argyris & Schon, 1978). Therefore, a learning organisation is one which fosters and enhances these activities for its members and members of the community in which it exists.

3.3 Learning organisation

West (1979) indicates that the learning organisation concept is embedded in the notion that innovative organisations should be designed as participative learning systems, which place an emphasis on information exchange and being open to enquiry and self-criticism. Pedler (1989) elaborate further on the concept of a learning organisation “a learning organisation is one which facilitates the learning of all its members and continuously transforms itself”. The concept of the learning organisation became popular following the writing of Senge (1990a). According to him “it is a place where: people continually expand their capacity to create the results they truly desire, where new and expansive patterns of thinking are nurtured, where collective aspirations are set free, and where people are continually learning how to learn together” (Senge, 1990a).

Garvin (1993) defined a learning organisation as “an organisation skilled at creating acquiring, and transferring knowledge, and modifying its behaviour to reflect new knowledge and insights”. The important component of this definition is the requirement that change occur in the way work gets done. A “learning organisation” is an

organisation that purposefully constructs structures and strategies so as to enhance and maximise organisational learning (Dodgson, 1993). Both of Garvin and Senge definitions imply a new ways of thinking about how people work together and the need of greater emphasis on reviewing current and past experiences.

Hodgetts (1994) similarly indicate that learning organisations are characterised by a strong commitment to generate and transfer new knowledge and that they utilise the external environment as a source of learning. Calvert (1994) maintains that organisations use learning as a means of attaining their goals and create structures and procedures that facilitate and support continuous learning and development. McGill (1994) define the learning organisation as “an organisation that can respond to new information by altering the very programming by which information is processed and evaluated”.

For the purpose of this thesis, a learning organisation is one that seeks to create its own future; that assume learning is an ongoing and creative process for its members and that develops, adapts and transforms itself in response to the needs and aspirations of people, both inside and outside itself. A learning organisation is one in which people at all levels, individually and collectively, are continually increasing their capacity to produce results they really care about. In summary, the learning organisation:

- is customer focused;
- has a high proportion of people learning-to-learn skills;
- continually questions and challenges the norm;
- is creative, prepared to experiment and is action-oriented;
- uses detection and correction activities as a learning experience and as a mechanism to transform the organisation’s accepted values and practices;
- has a vision of how it wants to be, communicates that vision effectively to its people and then works towards a common and shared purpose;
- builds learning opportunities for all into its strategy;
- finds a way of transferring and encoding the individual learning of its people into a cohesive and beneficial whole;
- communicates freely and openly with its customers, its people, its suppliers and all other stakeholders and frequently its competitors.

3.4 Organisational learning

Argyris & Schon (1978) two of the early researchers in this field, defined organisational learning as the process of “detection and correction of errors”. In their view “organisations learn through individuals acting as agents for them”. The individuals’ learning activities, in turn, are facilitated or inhibited by an ecological system of factors that may be called an organisational learning system”. Fiol and Lyles (1985) defined the organisational learning as the process of improving actions through better knowledge and understanding. This action is depends both on the situation of the organisation and the way that its members habitually tend to learn.

Organisational learning is more than the sum of the parts of individual learning (Dodgson, 1993). An organisation does lose out on its learning abilities when members leave the organisation. Organisational learning contributes to organisational memory. Thus, learning systems not only influence immediate members but also future members due to the accumulation of histories, experiences, norms, and stories. Kim (1993) notes that “analogous to individual learning, organisational learning is defined as increasing an organisation’s ability to take effective action”. Dodgson (1993) describes organisational learning as “the way organisations build, supplement, and organise knowledge and routines around their activities and within their cultures and adapt and develop organisational efficiency by improving the use of the broad skills of their workforces”.

Organisational learning involves individual learning, and those who make the shift from traditional organisation thinking to learning organisations develop the ability to think critically and creatively. These skills transfer nicely to the values and assumptions inherent in organisation development. Organisational learning is the outcome of three overlapping spheres of individual, team, and system learning as shown in Figure 3.1. All three kinds of learning take place simultaneously (Dixon, 1993). McGill *et al.* (1994) define organisational learning as the ability of an organisation to gain insight and understanding from experience through experimentation, observation, analysis, and a willingness to examine both successes and failures. Nevis (1995) describes organisation learning as the “capacity or processes within an organisation to maintain or improve performance based on experience”. Beeby and Simpson (1998) suggest new forms of thinking and acting. The present author agrees with descriptions of organisational

learning as where learning takes place that changes behaviour of individuals or groups within the organisation.

3.5 Organisational learning versus learning organisation

Learning at an organisational level is termed organisational learning and one can readily anticipate a certain amount of confusion stemming from the use of the terms “learning organisations” and “organisational learning”. However, as Jones and Hendry (1992) and Calvert *et al.* (1994) have warned about the two terms, even though they are closely inter-related are not one and the same thing. Indeed the two phenomena emphasise differing aspects: organisational learning highlights formal or structural issues such as training and knowledge and skills acquisition that tends to obscure the real issues behind the learning organisation. Participants of the focus groups organised by Calvert *et al.* (1994) also distinguish between the two concepts with the learning organisation described as “an organisation that excels at advanced, systematic collective learning”, whereas “organisational learning” refers to methods of collective learning.

An attempt towards a further clarification is offered by Tjepkema and Wognum (1996) “learning organisation responds to (and anticipates) changes in the environment by proactive organisational learning; moreover, it deliberately aims at improving its ability for learning and in order to learn on an organisational level a learning organisation makes use of the learning of all employees, therefore it strives to create a work environment which stimulates and supports learning”.

Lundberg (1995) proposes that organisational learning refers to certain processes of learning, which occur within organisations whereas the learning organisation refers to a systems level entity with particular characteristics and capabilities. Organisational learning involves individual learning. Those who make a shift from traditional organisation thinking to a learning organisation must be able to develop the ability to think critically and creatively. In this research, learning organisation described as the applied area of organisational learning. The main characteristics of a learning organisation is how to institutionalised the continual learning process such that it should be manifested in the underlying procedures, practices, code of conducts, routines and even in the products.

Based on the above, the present author proposes a working definition, which suggests that organisational learning can take a number of forms from induction training, which produce the individual skills as well as increase the skills recruitment, through the acquisition of knowledge to the dissemination of knowledge and increase the organisational competence pool.

3.6 Organisational learning levels

By making use of the concepts presented by Dixon (1993) learning may be addressed at three levels as shown in Figure 3.1.

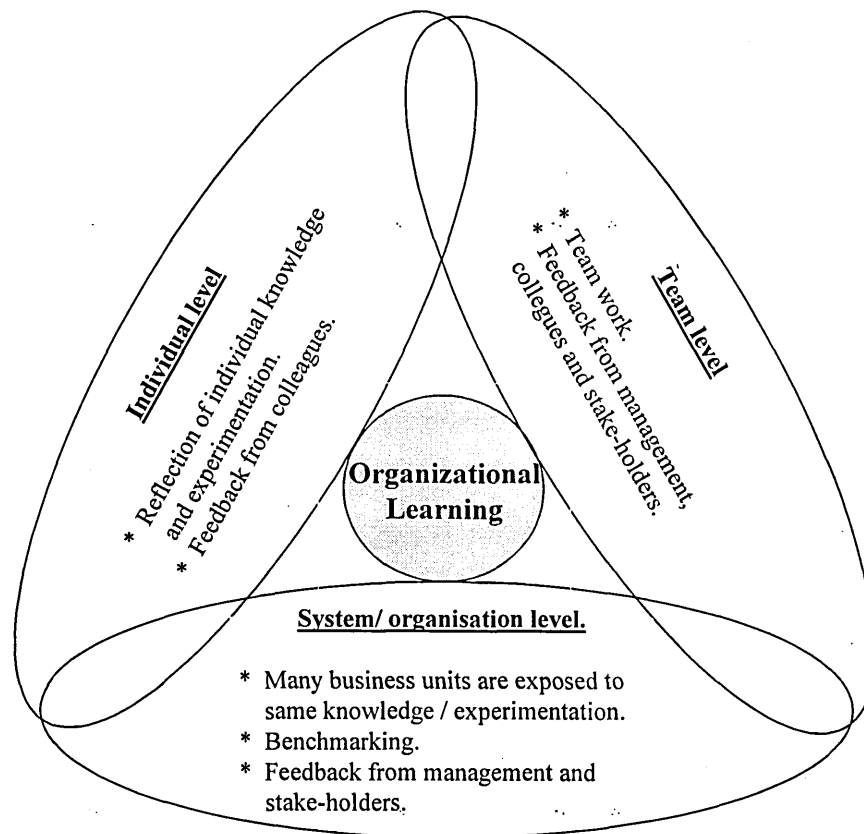

Figure 3.1: Organisation learning levels

(i) At the individual level

Learning takes place each time an individual (worker) reads a book (which could be a technical manual or underlying policies and procedures of the organisation), performs an experiment i.e. some improvisation to the current practices, for example, using a new way of customer service, and gets feedback from customer or colleagues.

(ii) At team level

At the business unit level, learning would take place when two or more workers learn from the same experience or activity. Team learning may involve new ways to address the team's responsibilities, or it may involve some aspect of the interaction between the members of the team themselves. A feedback of any nature from stakeholders, for example, from the line manager, supplier or customer would be considered to be a part of the learning process.

(iii) At the system/organisation level

It would take place when the organisation develops systemic processes to acquire, use, and communicate organisational knowledge. It embodies the individual as well as team level of learning and feedback. The learning has to be addressed at a much higher level such that each participating employee within the organisation understands and practices those systematic processes, for example, quality standards and procedures, database requirements of supplier or customers, stock control procedures etc. At the organisation level, learning is to be addressed through a favourable attitude and atmosphere such that learning becomes the ethics of the organisation.

3.7 Types of organisational learning

It is important to make the distinction between various kinds of learning, for example, “adaptive learning and coping” or what Peter Senge described as “generative learning” or Argyris & Schon (1978) idea of “double-loop learning”.

Argyris and Schon (1978) suggested that organisational learning is a process in which members of an organisation detect error and correct it by restructuring organisational theory of action, embedding the results of their inquiry in organisational maps and images. The key point here is that errors are detected and corrected or organisations cease to survive. The authors suggest three forms of learning, single-loop, double-loop and triple-loop. Single-loop learning is concerned with detecting and correcting errors in the current operating system. This is achieved by changing the ways in which tasks are performed within the same system of operation. Double-loop learning involves detecting errors, but finding solutions outside the current ways of thinking and acting. There is a change in the system itself. Triple-loop learning involves changing the ways of thinking about error detection and solution, a process often referred to as learning to learn.

Following Argyris and Schon (1978) Swieringa and Wierdsma (1992) distinguish between three levels of learning – single-loop learning: questioning how things are done; double-loop learning: questioning underlying purposes and why things are done; and triple-loop learning: questioning essential principles on which the organisation is based, and challenging its mission, vision, market position and culture.

A good description of the work Argyris & Schon (1978) is provided by Ross (1992). He argues that organisational learning involves the detection and correction of error. When such detection and correction enables the organisation to continue with current policies and objectives, the result is single-loop learning. Double-loop learning, on the other hand, is generated by detection-correction activities, which modify and change the organisation's fundamental norms and aims, often through challenging traditional norms and values and resolving subsequent conflict. In essence then, double-loop learning is about raising the learning mechanism of an organisation from the operational to the strategic level. While many organisations can and do achieve single-loop learning, the more valuable learning engendered through questioning and challenging the norm is more difficult to accomplish. The process of continually questioning and challenging the strategic norm is the very nature of a learning organisation. The present author in line with the definition of the three learning loops as, single-loop is linear, it is trying to find a better way to do a process. Double-loop learning bridges the gap between theory and practice. Whereas, triple-loop learning is learning about learning. Double-loop and triple-loop learning are concerned with the why and how to change the organisation while single-loop learning is concerned with accepting change without questioning underlying assumptions and core beliefs. Dodgson (1993) argue that learning can occur within different functions of the organisation such as research, development, design, engineering, manufacturing, marketing, administration, and sales.

3.8 Organisational learning processes

Huber (1991) describes four processes or constructs that contribute to organisational learning. These processes are: -

- knowledge acquisition,
- information distribution,
- information interpretation,
- organisational memory.

Learning occurs when an organisation acquires knowledge. **Knowledge acquisition** or facts and information is achieved by monitoring the environment, using information systems to store, manage, and retrieve information, carrying out research and development, carrying out education and training (Dodgson, 1993).

Information distribution refers to the process by which an organisation shares information among its units and members, thereby promoting learning and producing new knowledge or understanding. In order for information to be shared, such information must be interpreted. Information interpretation is the process by which distributed information is given one or more commonly understood meanings.

Organisational memory refers to the repository where knowledge is stored for future use. It is also called “corporate knowledge” or “corporate genetics” by Hamel and Prahalad (1994). Decision makers store and retrieve not only hard data or information but also “soft” information, that is, information with meaning. This soft or interpreted information can be in the form of tacit know-how, expertise, biases, experiences, lists of contacts, anecdotes, etc. Organisational memory plays a very critical role in organisational learning. Both the demonstratability and usability of learning depend on the effectiveness of the organisation’s memory. The major challenge for organisations exists in interpreting information and creating organisational memory that is easily accessible.

Buckler (1996) examines the processes by which individuals in organisations learn, and develop a learning process model to facilitate continuous improvement and innovation in business processes. The model is designed to be applied and used by managers working in organisations. He discusses: learning as a process that results in changed behaviour and the “how’s” of learning (techniques to help the learning process); the “why’s” of learning – creating an environment which provides meaning and the “what’s” of learning – enabling a focus on organisational goals; a learning process model.

Information interpretation can facilitate this learning process by supporting the processes of knowledge acquisition, information distribution, information interpretation, and organisational memory. With the displacement of people due to decreasing efforts, organisations are discharging vast amounts of organisational knowledge without

realising the long-term implications of such short-term actions. The only way organisations can preserve that knowledge and further promote organisational learning is to use information systems to store and retrieve such collective knowledge.

3.9 Creating learning organisation

Whilst the need to learn and change is indisputable, there is a general agreement that no right model of a learning organisation exists (e.g. Dale, 1994). A learning organisation works to create values, practices and procedures in which learning and working are synonymous throughout the organisation. Senge (1990a) offers a framework for learning organisation founded on five key areas or disciplines. A distinct order of the learning organisation principles is system thinking and personal mastery led to shared vision; team learning and mental models as shown in Figure 3.2. Appendix 3.1 illustrates more details of Senge five disciplines.

In fact, Senge (1990b) refers to the building learning organisations via three waves: -

- The first wave involves the front-line worker (empowerment).
- The second wave changes the way we work (five disciplines).
- The third wave follows on from the first two, and it institutionalises learning for all members of the organisation. It will not occur until the second wave is completed in all areas.

Pedler (1991) identifies some necessary but not sufficient conditions for the creation of a learning organisation. These conditions are:

1. A corporate learning strategy;
2. Participative policy making;
3. Information technology harnessed to inform and empower people to ask questions and take decisions based on available data;
4. Formative accounting, where accounting systems are designed to assist learning from decisions;
5. Internal exchange;
6. Flexibility is rewarded;
7. Front-line workers are expected to be, and are used as, environmental scanners;
8. Inter-organisation learning takes place, where learning is not restricted to the organisation, but extends to organisations which are suppliers, customers, or even competitors;

9. A climate is created which supports learning;
10. Self-development is for all members of the organisation.

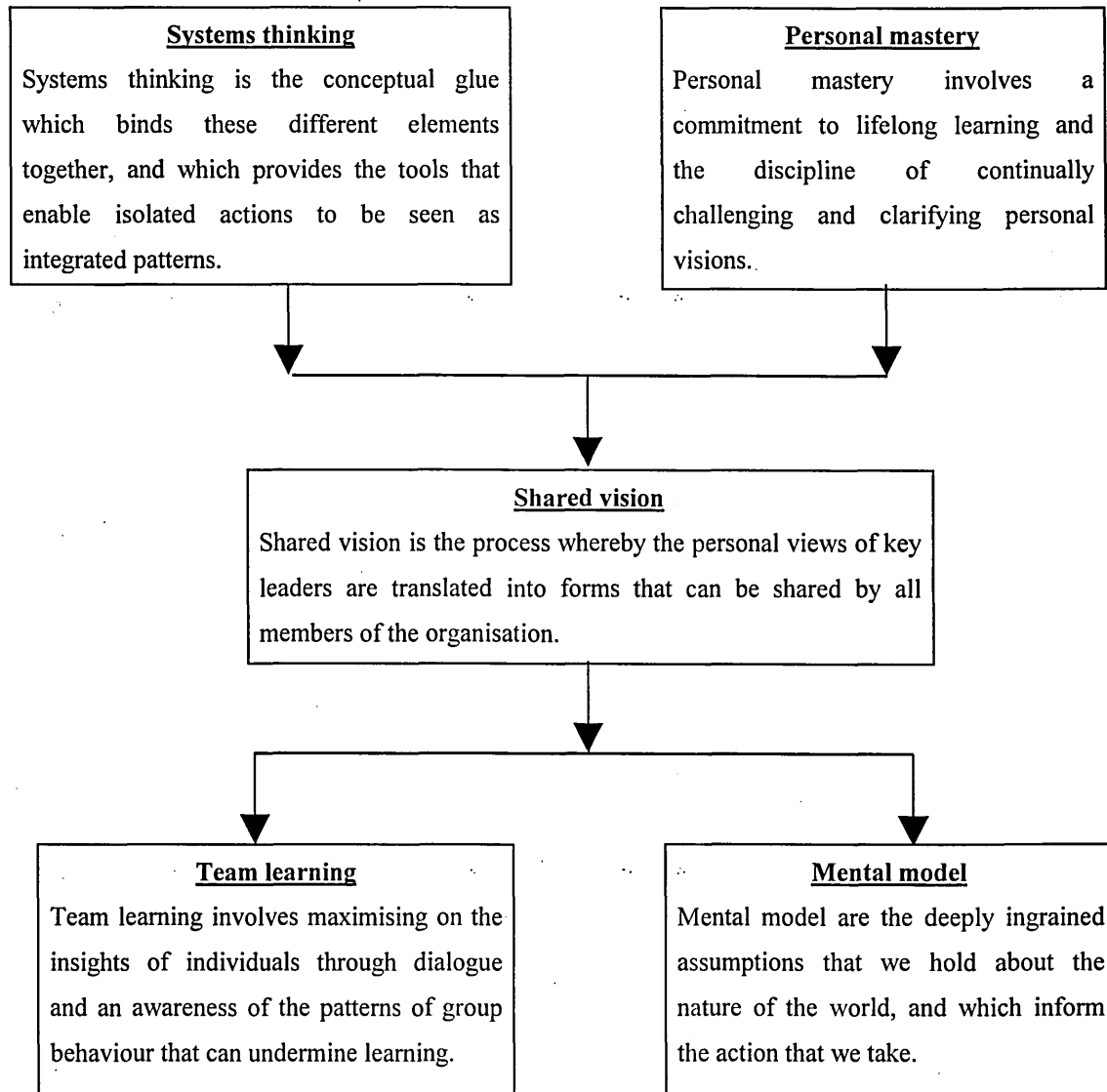

Figure 3.2: Senge's five key disciplines (1990a).

Garvin (1993) suggests that, to become a learning organisation, organisations need to be skilled at the following five activities:

1. Systematic problem solving:

Relates to the philosophy and methods of the quality movement, relying on scientific method rather than guesswork; uses actual data rather than assumptions and simple statistical tools.

2. Experimentation with new approaches:
Systematic searching for and testing new knowledge; motivated by opportunity and new perspectives and not by current difficulties
3. Learning from their experiences and past history:
A review of successes and failures; reflecting and self-analysis
4. Learning from experiences and best practices of others:
Benchmarking; looking outside the immediate environment; openness to the outside world; environmental scanning
5. Transferring knowledge quickly and efficiently throughout the organisation:
Mechanisms in place to facilitate the process; written and oral reports; site visits; tours; rotation programmes; education and training programmes.

Hitt (1995) emphasises the purpose of a learning organisation in his definition “an organisation that is striving for excellence through continual organisation renewal”. He adapts the McKinsey 7-S framework to provide a systems view of the learning organisation.

In summing up, Hitt (1995) observes that the learning organisation is a new paradigm that reflects a process rather than an end state. He observes: embracing and implementing the paradigm of the learning organisation will be no easy task. There will be obstacles, one of the most challenging is to overcome the resistance of those managers who have fully embraced the traditional organisational paradigm – and are successful. Why should they change? There is an important reason why they should change, and that is the quest for excellence. In this quest, managers want to know how to achieve excellence and how to maintain it. The learning organisation points the way: excellence through organisational renewal (Hitt, 1995).

Peters (1996) proposes a syllabus-driven approach for the aspiring learning organisation, interlinking six areas, which can be addressed by designing interventions for individuals, teams and organisational systems. The syllabus areas are:

1. Learning about the participant’s own job in the organisation and how to do it better.
2. Learning how to create alignment between culture and strategy in the organisation so that initiatives “fit” the context from inception to implementation.

3. Learning about the future by exploring the value of techniques for scenario planning and anticipating the likely implications for personal and organisational competency development.
4. Learning about the operating environment and the supply chain – essentially Peter Senge’s “fifth discipline” of systems thinking.
5. Learning how to challenge existing schools of thinking and avoid myopia so that personal and organisational mindsets are open to change and to new ideas.
6. Developing an organisational memory for the purpose of capturing, storing and retrieving knowledge and expertise.

The syllabus is for the organisation as a whole and its members who should participate according to their personal learning agenda and the organisational imperative. However, the sequence of its implementation is of some significance. Peters (1996) suggests that the learner’s own job should be the starting point, as improvements here will yield organisational benefits from the outset. After this, the longer-term debates should be established about the future, future competencies and how to network learning throughout the organisation’s supply chain. The framework also provides a basis for monitoring the kind of organisational adjustments needed to maintain creativity and productivity and for reutilising improvements by creating and drawing on a knowledge base that constitutes the organisation’s bank of knowledge capital. In essence, the learning organisation is one that has found a workable and meaningful way of systemising organisational learning and all its component parts.

In summary, a learning organisation is one in which the learning strategy is more than a human resource or staff development strategy – it is a core component of all operations. This is only achieved by attention to both individual learning and organisational learning.

3.10 Individual learning in a learning organisation

Learning is desirable but requires both individual and team double-loop learning. March and Olsen (1975) identified four learning conditions which would prevent individual knowledge from influencing the organisational mind set and more seriously, teach the organisation to learn wrong things. *First*, “role constrained learning” occurs when the individual who acquires new insight and knowledge is unable to influence behaviour in the organisation because of his or her lowly position. *Second* “audience” learning occurs

when a particular individual is able to affect organisational behaviour and learning in a spurious way. *Third*, superstitious learning occurs when the nature of environmental activity and change is misunderstood, and therefore unrelated to (although not unaffected by) the inferences and activities learned by individuals and the organisation. *Fourth*, ambiguous learning occurs when the individuals concerned are incapable of clearly understanding the causal links between environment and action.

Learning for an organisation only has meaning in the sense that organisational behaviour is modified in the light of what individuals have learned. Argyris & Schon (1978) argue that organisational learning is the collective experience of individuals within the organisation evident only when procedures change in the light of what has been learned.

Mumford (1994) underlines the importance of individual learners in building a learning organisation. The learning organisation depends absolutely on the skills, approaches and commitment of individuals of their own learning. An essential ingredient in the learning organisation is the way that the organisation seeks to improve the capacity of individuals to recognise and take advantage of learning opportunities. It is important to emphasise that all members of the organisation need to participate in individual learning, and that their managers need to view this as a central responsibility.

3.11 Models of organisational learning

Argyris & Schon (1978), Mitroff (1983), and Senge (1994) are among the few who have attempted to integrate strategic, systemic, psychological and sociological perspectives, and relate them to learning at individual, team and organisation levels. For example, Argyris & Schon (1978) discuss ways of changing inhibiting “theories in use” through awareness of their disabling effects, so as to generate valid information, informed choices and internal commitment. Argyris (1990) discusses defensive behaviour in organisations, pointing to such processes as blaming, inertia, upwards communication, and budget games. Senge (1990a) re-emphasises the need for systematic diagnosis and the need to recognise, challenge and confront defensive routines that inhibit learning. The needs for active listening, for balancing inquiry and advocacy, for avoiding premature conclusions and for addressing gaps between expressed theories and theories in use are also stressed, as is the value of “creative tension” between future vision and current analysis. Mitroff (1983) links organisational

forms and strategic orientations with deep-seated personal beliefs and preferences, including learning styles, using a Jungian frame of analysis.

Others have tended to focus on developing models of learning organisations that identify their essential characteristics and attributes. Beckhard and Pritchard (1992) list the following features: a clear picture of both learning and doing; rewards that encourage questioning, challenging and innovation; performance and career reviews that focus both on long-term learning and short-term doing; feedback processes that focus on performance and learning; information systems that focus both on lessons and results; development programmes that support this strategy; communication strategies that focus on learning; and strategic planning processes that involve learning as well as doing.

Attempting to integrate concepts of organisational learning with individual learning in organisations Pedler *et al.* (1991) reject the notion that there is one set formula or right answer. Nevertheless, they propose 11 key attributes; a learning approach to strategy; participative policy making; informing; formative accounting and control; internal exchange; reward flexibility; enabling structures; boundary workers as environmental scanners; inter-organisation learning; a learning climate; and self-development for all.

Jones and Hendry (1992 & 1994) have developed a phase or stage model of learning in organisations. The foundation phase is focused on the basics, laying the basis for future learning. The formation phase encourages and develops skills in self-managed learning and self-development. As the learner makes new learning demands, the organisation needs to make available additional resources. At the continuation phase, both the individual and the organisation are becoming more independent and innovative, providing support for stressed and plateaued employees. With the transformation and transfiguration phases, the organisation is moving from encouraging organisational learning to becoming a learning organisation. At the transformation stage it is concerned with cultural and structural changes, learning to think and act differently, experimentation and ethical issues, individual development and entrepreneurship, coaching and facilitating, and with reflection and support. At the transfiguration stage, the emphasis is on individual as well as social welfare and improvement, concern for values, mission and global integration. There is no prescription as to best practice, and

allowances are made for different parts of the organisation to develop and change at different rates (Mabey and Salaman, 1995).

Buckler (1996) develops a learning process model to facilitate continuous improvement and innovation in business processes. The model is designed to be applied and used by managers working in organisations. He discusses learning as a process that results in changed behaviour and the “how’s” of learning (techniques to help the learning process); the “why’s” of learning – creating an environment which provides meaning and the “what’s” of learning – enabling a focus on organisational goals; a learning process model.

3.12 Learning organisation: the way forward

Through learning organisations adapt to change, avoid the repetition of past mistakes, and retain critical knowledge that would otherwise be lost. Therefore in the present author’s view in 1990’s and beyond the amount of learning, which takes place within an organisation, would make a critical factor for its survival and success. A number of factors are listed in the following to support this view.

(i) Increased pace of change and competitiveness

- The fact is that many organisations have not survived change. A report has suggested that one-third of the Fortune 500 organisations listed in 1970 had vanished by 1983 (Dixon, 1993). Peters and Waterman identified 43 “excellent” organisations in 1982, which had demonstrated superiority on six critical financial yardsticks over a period of 20 years. Five years later, only 14 of them were in the excellent category; some had disappeared entirely and many were in trouble (Dixon, 1993).
- Market forces, such as globalisation, higher customer expectations, greater competitive pressures, shorter cycle times signals a need to work differently. The ability to adapt quickly stems from an ability to learn; i.e. the ability to assimilate new ideas and to transfer those ideas into action faster than a competitor (Ulrich, 1993).

(ii) Workforce competence and the changing work skills

- In this age of information society, knowledge and skills of the workforce becomes the primary means by which organisations compete. As knowledge becomes more central to competitiveness, the ability of individuals and organisations to learn becomes a primary means for winning (Ulrich, 1993).
- With the concept of “life long learning” learning and work have become synonymous terms. Rather than learn in preparation for work, employees must learn their way out of the work problems they address. Learning is not something that requires time out from being engaged in productive activity: learning is the heart of productive activity (Dixon, 1993).

Learning is now so essential for career success, corporate survival, and national prosperity that it no longer makes sense to relegate it to certain institutions or to particular periods in one’s life.

3.13 Summary

The purpose of the organisational transformation, that is achieved through a learning organisation, is to enable the organisation to search for new ideas, new problems and new opportunities for learning from which competitive advantage can be culled in an increasingly competitive world. Learning also increases information sharing, communication, understanding, and the quality of decisions made in organisations.

Senge (1990a, 1990b) provides a valuable contribution to the learning arena through his disciplines of personal mastery, mental models, team learning, and systems thinking. However, he does not acknowledge explicitly the learning output of new knowledge or the distribution of the learning throughout the organisation.

Garvin (1993) has argued that the learning organisation should be meaningful, manageable, and measurable. The three Ms may indicate why it is so difficult to find examples of learning organisations, each M is independent, yet like the learning organisation itself, is interdependent. Thus although many definitions have attempted to capture the essence of the learning organisation it still remains difficult to move the theory to reality without effective measurement tools. Measurements must be taken to

assess the current, in order to determine which actions must be taken to manage the progression towards a learning organisation.

The overview in this Chapter has tended to focus on the learning process; many of the recipes offered by authors in this field are concerned with the social interactions and cultural precedents, which encourage the learning process within teams and between teams in organisations. Rather less attention is paid to the outcome of the learning process. Whilst one of these outcomes will be the ability to continue to learn, the other is the set of skills and knowledge that are created within the organisation, and are accessible to those who might be in a position to use them in contributing towards the vision of the organisation. More recently contributions to the debate have considered the knowing, and knowledge creating, organisation, and the field of knowledge management has encouraged the development of perspectives on how knowledge can be created and managed.

As Block (1995) said, "If we want to create organisations that really work, however, we need to do more than reengineer our process and systems, we need to examine our ideas about power, community, purpose, and privileged and translate them into a whole strategy for our organisations and institutions".

As concluded in this Chapter and Chapter 2, however, learning is required at both the conceptual and operational levels and continuous improvement required continuous learning. Also, total quality management and organisational learning have complementary strength that can greatly enhance an organisation's ability to improve its performance through a more balanced learning process. The integration of the two approaches can play an important role in helping organisations to develop new norms and values, where front line people work in self managed group, managers develop their research skills and leaders become more like philosophers who inspire the human spirit.

In order to establish that link, the essential elements contributed to total quality management and organisational learning are identified in the next Chapter. Also, the next Chapter would examine the relationship between total quality management and organisational learning to developed the conceptual framework of the learning organisation.

3.14 References

- Argyris, C., & Schon, D., (1978), "Organisational learning: A theory of action perspective", Reading: Addison Wesley.
- Argyris, C., (1990), "Overcoming Organisational Defences" Boston: Allyn & Bacon.
- Beckhard, R. and Pritchard, W., (1992), "Changing the Essence: the Art of Creating and Leading Fundamental Change in Organisations", Jossey-Bass, San Francisco, CA.
- Beeby, M. and Simpson, P., (1998), "Barriers, boundaries and leaks in an organisation development dimension", *The Leadership and Organisation Development Journal*, Vol. 19, pp. 353-61.
- Block, P., (1995), "Stewardship; A governance strategy for the learning organisation, key note address", *Int. Conf. Building Organisational Learning Infrastructures*, Boston, MA, September, pp.18-20
- Buckler, B., (1996), "A learning process model to achieve continuous improvement and innovation", *The Learning Organisation*, Vol. 3 No. 3, pp. 31-9
- Calvert, G., Mobley, S. and Marshall, L., (1994), "Grasping the learning organisation", *Training and Development*, Vol. 48 No. 6, pp. 38-43.
- Dale, M., (1994), "Learning organisations", in Mabey, C. and Iles, P. (Eds), *Managing Learning*, Routledge with the Open University, London, New York, NY, pp. 22-3.
- Dixon, Nancy, (1993), "Organisational Learning." Ottawa; Conference Board of Canada Report 111-93.
- Dodgson, M., (1993), "Organisational learning: A review of some literatures. *Organisation Studies*, 14/3: 375-394.
- Fiol, C., & Lyles, M., (1985), "Organisational learning" *Academy of Management Review*, 10, 803-813
- Garvin, D., (1993), "Building a learning organisation", *Harvard Business Review*, July-August, pp. 78-91.
- Hamel, G. and Prahalad, C. K., (1994), "Competing for the Future", Harvard Business School Press, Boston, MA
- Hitt, W. D., (1995), "The learning organisation: some reflections on organisational renewal", *Leadership & Organisation Development Journal*, Vol. 16 No. 8, pp. 17-25.

- Hodgetts, R., Luthans, F. and Lee, S., (1994), "New paradigm organisations: from total quality to learning to world class", *Organisation Dynamics*, Vol. 22 No. 3, Winter.
- Huber, G. P., (1991), "Organisational learning: the contributing processes and the literatures", *Organisation Science*, Vol. 2 No. 1, pp. 88-115.
- Jones, A.M. and Hendry, C., (1992), "The Learning Organisation: A Review of Literature and Practice", HRD Partnership, London.
- Jones, A.M. and Hendry, C., (1994), "The learning organisation: adult learning and organisational transformation", *British Journal of Management*, Vol. 5, pp. 153-62.
- Kim, D. H., (1993), "The link between individual and organisation learning", *Sloan Management Review*, autumn, pp. 37-50
- Lundberg, C.C., (1995), "Learning in and by organisations: three conceptual issues", *International Journal of Organisational Analysis*, Vol. 3, pp. 10-23. pp. 1-4.
- Mabey, C. and Salaman, G., (1995), "Strategic Human Resource Management", Basil Blackwell, Oxford.
- March, J. and Olsen, I., (1975), "The uncertainty of the past: organisational learning under ambiguity", *European Journal of Political Research*, Vol. 3, pp. 141-71.
- McGill, M. E. and Slocum, J. W., (1994), "The Smarter Organisation: How to Build a Business that Learns and Adapts to Marketplace Needs". New York: Wiley.
- McLeod, W. T., (1982), "The New Collins Concise English Dictionary", William Collins Sons & Co. Ltd, Glasgow
- Mitroff, (1983), "Stakeholders of the Organisational Mind: Towards a New View of Organisational Policy Making", Jossey-Bass, San Francisco, CA.
- Mumford, A., (1994), "Individual and organisational learning: the pursuit of change", in Mabey, C. and Iles, P. (Eds), *Managing Learning*, Routledge with the Open University, London, New York, NY., pp. 77-86.
- Nevis, E. C., DiBella, A. J. and Gould, J. M., (1995), "Understanding organisations as learning systems", *Sloan Management Review*, Vol. 36 No. 2, pp. 73-85.
- Pedler, M., Boydell, T. and Burgoyne, J., (1989), "Towards the learning company", *Management Education and Development*, Vol. 20 Part 1
- Pedler, M., Burgoyne, J. and Boydell, T., (1991), "The Learning Company", McGraw-Hill, Maidenhead
- Peters J., (1996), "A learning organisation's syllabus", *The Learning organisation*, Vol. 3, No. 1, pp. 4-10.

- Ross, K., (1992), "The learning company", Training and Development, July
- Senge, P., (1990a), "The Fifth Discipline: the Art and Practice of the Learning Organisation", Doubleday Currency, New York, NY
- Senge, P., (1990b), "The leader's new work: Building learning organisations", Sloan Management Review, Fall: 7-23
- Senge, Peter, M. (1994), "The Fifth Discipline Field book: Strategies and Tools for Building a Learning Organisation", New York: Doubleday.
- Swieringa, J. and Wierdsma, A., (1992), "Becoming a Learning Organisation: Beyond the Learning Curve", Addison-Wesley, London.
- Tjopenkhama, S.W. and Wogrum, I. (1996), "From trainer to consultant? Roles and tasks of HRD professionals in learning orientated organisations", ECLO Conference Proceedings, Copenhagen.
- Ulrich, Dave; Von Glinow, Mary Ann; Jick, Todd., (1993), "High-Impact Learning; Building and Diffusing Learning Capability", Organisational Dynamics, Autumn
- West, C. H., (1979), "The many meanings of research utilisation", Public Administration Review

CONCEPTUAL FRAMEWORK FOR LEARNING ORGANISATION

4.1 Introduction

The present author's understanding is that TQM initiative can only be regarded successful if a new working environment has been created in which people are able to learn. Using the TQM, and organisational learning studies conducted in Chapter 2 and 3 respectively, evolution of TQM is offered and transformation from TQM to learning organisation is described in a step-by-step procedure as shown in the earlier sections of this Chapter. Furthermore, this Chapter discusses the ten most notable authors in total quality management and organisational learning to identify the principal elements of TQM and the organisational learning characteristics.

This Chapter concludes by adapting the enablers & results mechanism of European Foundation for Quality Management (EFQM) to construct the learning organisation framework. Also these enablers and results are grouped and evaluated under the standards operations management framework of Technologies and tools (T), Organisation and system (O), and People (P).

4.2 Quality evolution

Quality movement started with simple *Inspection-based systems* where an organisation would employ specific people to check work visually that had already been produced and sort the good from the bad. This method of inspection was thought to be the only way of ensuring quality. In a manufacturing environment, this checking of conformance to requirements would be applied to incoming goods, manufactured components and assemblies at various points in the process and once again when the goods were finished and ready for shipment to the customer. The basis of these systems was that poor quality product found by the inspectors would be segregated from that of good quality. This would be scrapped, reworked or sold as lower quality (see Figure 4.1). This system can cause dissatisfaction to the customer. Therefore later written specifications,

measurements and standardisation were introduced. This encouraged the development of methods for improving production efficiency in factories (Dague, 1981).

During the Second World War, quality began to be verified by full time inspectors rather than by the workers themselves. Subsequently **Quality Control** was evolved that prescribes a number of pre-requisites such as a drawing control system in place, paper work and procedures control system, raw material and product testing, self inspection by operators and many other ways of ensuring greater process control and reduced non-conformance (Figure 4.1) (Hafeez *et al.*, 1997). However a final visual inspection of the product was still used as a safeguard to customers from receiving product that did not meet the specification.

During the boom of mass-production just after the Second World War, it was widely recognised that the detection type system was unable to eliminate the root cause of the quality problem. The concept of continuous improvement started developing its roots as people realised that quality issues are to be addressed at a wider scale, i.e. by directing organisational efforts towards planning and preventing problems happening at source. This led to the third stage of quality movement, namely, **Quality Assurance**.

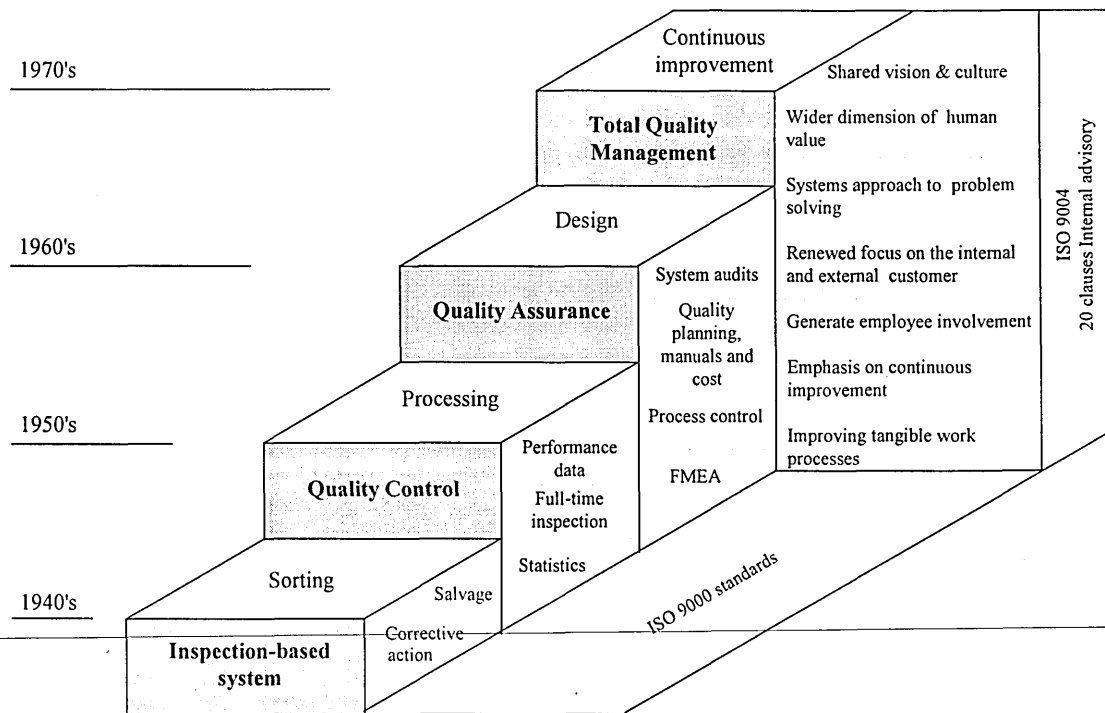

Figure 4.1: Evolution of quality

Quality assurance is a prevention-based system, which aims to improve product and service quality as well as increase productivity by placing the emphasis on product, service and process design. It attempts to prevent non-conforming products being produced in the first place by streamlining the source activities. The quality system, which is set in place, is documented and audited to ensure that it is adequate against defined standards. It also ensures that the organisation is complying with the most effective system for ensuring product and service quality.

Experience in Quality Assurance showed the changing from detection to prevention requires much more than a set of quality management tools and systems. It needs continuous improvement. This requires development of a new operating philosophy that demands a change in management style and way of thinking. Such concepts paved the way towards the realisation of *Total Quality Management* (see Figure 4.1)

4.3 Total quality management elements

On the basis of an extensive literature review, the work of ten authors who the present author's believed have had the major influence in developing the total quality management subject have been selected. Through a careful content analysis the twenty-eight elements have been identified, which in the present author's view contribute to TQM. They can be generally categorised under the well-established operations research dimensions of technologies and tools (T), organisation and system (O), and people (P).

Table 4.1 indicates the importance of each of these elements based on the present author's subjective assessment of the work of the ten well-known authors in the total quality management field. The level of measurement used to identify the element weighting is a five-point scale with no change, low, medium, high and substantially high which are 0.0, 0.25, 0.50, 0.75, and 1.00 respectively. The definition of each element critically identified and gives a linear scale from 0.0 to 1.0. If one Guru doesn't study one element he scores 0.0 (no change). In case a Guru study or emphasis two critical factors he scores 0.5 (medium). Similar rules were developed to identify the elements weighting.

Total Quality Management Elements	Authors										Weighting (total = 10)		
	Deming	Juran	Crosby	Oakland	Ishikawa	Feigenbaum	Kanji	Taguchi	Mellor	Shingo			
Technologies (Tools)	Single-loop learning	●	○	○	○	○	○	○	○	○	○	○	3.50
	Problem solving	●	○	○	○	○	○	○	○	○	○	○	4.75
	Benchmarking	○	○	○	○	○	○	○	○	○	○	○	3.00
	Action learning	○	○	○	○	○	○	○	○	○	○	○	4.75
	Continuous improvement	○	○	○	○	○	○	○	○	○	○	○	6.50
	Learning cycle	○	○	○	○	○	○	○	○	○	○	○	1.75
	Data management	○	○	○	○	○	○	○	○	○	○	○	3.00
Organisation (systems)	Culture	○	○	○	○	○	○	○	○	○	○	○	6.25
	Organisation structure	○	○	○	○	○	○	○	○	○	○	○	3.75
	Communication	○	○	○	○	○	○	○	○	○	○	○	4.25
	Shared vision	○	○	○	○	○	○	○	○	○	○	○	3.00
	Performance management	○	○	○	○	○	○	○	○	○	○	○	4.75
	Leadership	○	○	○	○	○	○	○	○	○	○	○	3.50
People	Management responsibility	○	○	○	○	○	○	○	○	○	○	○	4.00
	Empowerment	○	○	○	○	○	○	○	○	○	○	○	4.75
	Rewards/recognition	○	○	○	○	○	○	○	○	○	○	○	2.50
	Team learning	○	○	○	○	○	○	○	○	○	○	○	5.50
	Training & education	○	○	○	○	○	○	○	○	○	○	○	4.75
	Weighting (total = 18)	11.50	9.50	9.50	8.00	7.50	6.50	6.00	5.25	5.25	4.25		

Key: ○ No change (0.0) ○ low (0.25) ○ Medium (0.5) ○ High (0.75) ● Substantially high (1.0)

Table 4.1: Comparative study of ten Gurus showing emphasis on various TQM elements.

Table 4.1 identifies the minimum and maximum ratings of these elements. The most important element is the continuous improvement (6.50). This matches with the objectives of TQM as a continuous improvement process. For TQM to succeed, and to achieve the objective, requires a commitment to learning and acquiring new knowledge and skills. The learning cycle element scored very low (1.75) provide why TQM implementation success rates remain distressingly low.

4.4 Learning organisation elements

The literature survey conducted in this research has identified twenty-eight factors, which in the present author's view forms the essential building blocks of a learning organisation. The present author's has categorised these under the well-established operations management dimensions of Technology (and tools), Organisation (processes and systems) and People. Under these dimensions he has further categorised the twenty-eight elements as the components of the first wave (TQM) or the second wave (dynamic system wide performance), or the third wave of quality (learning organisation). Table 4.2 indicates the importance of each of these elements based on the present author's subjective assessment of the work of the ten well-known authors in the organisational learning field, which is described in the previous section. Please note that in Table 4.2, dynamic system wide performance entails all the aspects of TQM. Similarly learning organisation elements comprises all the TQM and dynamic system wide performance elements along with the additional elements.

Table 4.2 illustrates that most of the selected authors have emphasised the importance of single-loop, double-loop and triple-loop learning. Therefore on average these have scored relatively high ratings, respectively 75%, 62.5%, and 65% for the single-loop, double-loop and triple-loop learning. However learning orientation, information system, information management, knowledge management, communication, shared vision, establishing learning communities, learning strategy, empowerment, and training and education have scored relatively the medium ratings (50% to 60%).

Learning organisation elements		Authors										Weighting (total = 10)			
		Senge	Garvin	Argyris	Dodgson	Fiol	Nevis	Dixon	Huber	Mason	Morgan				
Technologies (Tools)	Learning organisation	Single-loop learning	●	●	●	●	●	●	●	●	●	●	●	●	7.50
		Problem solving	●	●	●	●	●	●	●	●	●	●	●	●	4.75
	Dynamic system wide performance	Benchmarking	●	●	●	●	●	●	●	●	●	●	●	●	4.00
		Action learning	●	●	●	●	●	●	●	●	●	●	●	●	4.25
	Learning organisation	Continuous improvement	●	●	●	●	●	●	●	●	●	●	●	●	4.50
		Learning cycle	●	●	●	●	●	●	●	●	●	●	●	●	3.75
	Learning organisation	Data management	●	●	●	●	●	●	●	●	●	●	●	●	3.50
		Learning orientation	●	●	●	●	●	●	●	●	●	●	●	●	5.50
	Learning organisation	Information system	●	●	●	●	●	●	●	●	●	●	●	●	6.00
		Double-loop learning	●	●	●	●	●	●	●	●	●	●	●	●	6.25
Organisation (systems)	Learning organisation	Information management	●	●	●	●	●	●	●	●	●	●	●	●	5.00
		Triple-loop learning	●	●	●	●	●	●	●	●	●	●	●	●	6.50
	Learning organisation	Knowledge management	●	●	●	●	●	●	●	●	●	●	●	●	5.75
		Culture	●	●	●	●	●	●	●	●	●	●	●	●	4.00
	Learning organisation	Organisation structure	●	●	●	●	●	●	●	●	●	●	●	●	4.50
		Communication	●	●	●	●	●	●	●	●	●	●	●	●	5.50
	Learning organisation	Shared vision	●	●	●	●	●	●	●	●	●	●	●	●	5.00
		Performance management	●	●	●	●	●	●	●	●	●	●	●	●	3.75
	Learning organisation	Fostering new ways of thinking	●	●	●	●	●	●	●	●	●	●	●	●	4.25
		Organisation's potential behaviours	●	●	●	●	●	●	●	●	●	●	●	●	4.75
People	Learning organisation	Establish learning Communities	●	●	●	●	●	●	●	●	●	●	●	●	5.50
		Learning strategy	●	●	●	●	●	●	●	●	●	●	●	●	5.75
	People	Leadership	●	●	●	●	●	●	●	●	●	●	●	●	4.25
		Management responsibility	●	●	●	●	●	●	●	●	●	●	●	●	3.25
	People	Empowerment	●	●	●	●	●	●	●	●	●	●	●	●	6.00
		Rewards/recognition	●	●	●	●	●	●	●	●	●	●	●	●	4.25
	People	Team learning	●	●	●	●	●	●	●	●	●	●	●	●	4.50
		Training & education	●	●	●	●	●	●	●	●	●	●	●	●	5.00
	Weighting (total = 28)		21.00	18.75	18.25	12.75	12.75	12.50	11.50	11.25	9.25	9.50			

Key: ○ No change (0.00) ● low (0.25) ● Medium (0.50) ● High (0.75) ● Substantially high (1.00)

Table 4.2: Comparative study of ten Gurus' showing emphasis on various learning organisation elements

Whereas problem solving, benchmarking, action learning, continuous improvement, culture, organisation structure, fostering new way of thinking, organisation's potential behaviour, leadership, rewards/recognition and team learning have scored relatively low ratings (40% to 50%). Learning cycle, data management, performance management and management responsibility have scored very low ratings (less than 40%).

To the present author's view, each column of Table 4.2 gives a very compact picture how did one Guru has imagined the importance of these building blocks. By measuring the vertical scores, it is clear that Senge, Garvin, and Argyris have been very influential in shaping the field of organisational learning. The findings above concentrate on the establishing of the learning loops. Learning loops focus the organisation on continuously collecting information and using it to improve actions through better knowledge and understanding

4.5 The link between TQM and learning organisation

TQM's main tenets were the proactive pursuit of continuous improvement, understanding the internal customer concept, denoting quality as each employee's responsibility; and organisation wide training and development. However, some believe the TQM philosophy has its limits. According to Sitkin *et al.* (1994) TQM is in danger of being "oversold", inappropriately implemented and ineffective. The authors argue that the marketing of TQM has become an industry of its own, and the understanding of TQM has been diffused as a result of its blanket application. Luthans *et al.* (1995) state TQM is not able to meet future-oriented challenges, and suggests the time is right to go beyond TQM. Some suggest that the learning organisation is the next logical step in this evolution of change.

The literature reveals several authors strongly believe in the mutual dependence of TQM and learning organisations. The success of TQM is related to an organisation's ability to learn, to absorb, to adapt and to apply conceptual changes and integrate them throughout the organisation. Senge (1994b) states that the corporation without practising the discipline of learning cannot excel. Brian (1990) argued that no organisation could overlook learning because it is a strategic tool to continuous improvement in quality and productivity.

According to Barrow (1993) the connection between TQM and organisational learning is evident in two ways. First, there is a cause and effect relationship; i.e. learning is an intended outcome of TQM. Second, there is a correlation between process improvement and organisational learning: the two operate in a concurrent and integrated manner. Garvin (1993) states that if TQM is practiced as a philosophy (i.e. continuous improvement) as well as a set of techniques, i.e. Plan, Do, Check, Act or PDCA cycle, then it can be a vehicle for organisational learning. Watkins and Golembiewski (1995) state organisational development and TQM have been building learning organisations all along.

In the present author's view, a learning organisation should be an organisation skilled at creating, acquiring and transforming knowledge, and at reforming the behaviour patterns of workers and decision makers to reflect new knowledge and insights so as to evaluate total quality management in every process. Organisation failing to grasp the basic truth that TQM requires a commitment to learning is the reason that failed programme outnumbers successes, and success rates remain distressingly low. In order for TQM to succeed the entire workforce must acquire new knowledge, skills and abilities. One objective of the present study is to develop a conceptual linkage between TQM and organisational learning in order to improve organisational and people performance and to speed up the learning processes within an organisation. Figure 4.2 provides a linkage between systems thinking and total quality management, which raise the present study as "learning flywheel" effect.

Senge (1994b) believes that the TQM philosophy has been founded on the learning concept. In fact his "learning wave" theory encapsulates the feelings of many authors, academics and practitioners who believe that TQM is the first step toward a learning organisation. The first wave focused on frontline workers and managers championed continuous improvement using empowerment of employees, quality training and Deming's (1986) PDCA Cycle, and competitive benchmarking. The second wave focused on how managers foster ways of thinking and interacting conducive to continual learning about the dynamic, complex, and issues that determines system wide performance. The third wave is a synthesis of the first two waves in which learning becomes an inescapable way of life. The third wave involves the institutionalisation of learning.

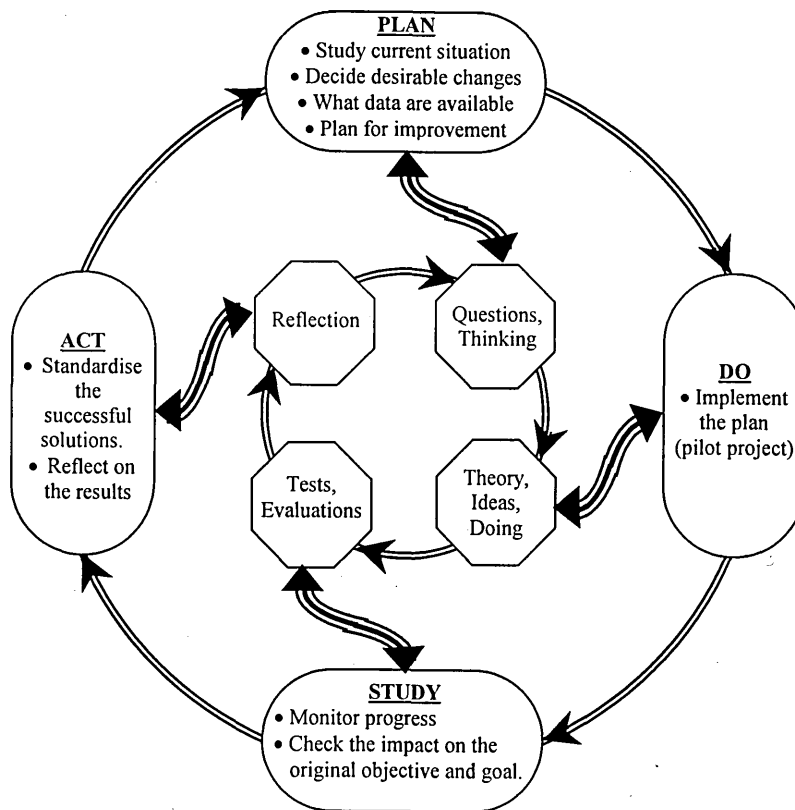

Figure 4.2: Correlation between total quality and organisational learning (Learning Flywheel)

Senge (1995) describes the necessary new approach as the “third wave” after the initial “waves” of total quality management and the organisational learning and points out that the “tools” of this new approach have not yet been developed. Continuous improvement is the cornerstone of TQM. Oakland (1993) claims that the three basic principles of never-ending improvement are to focus on the customer, understand the process, and involve the people. The present author believes that TQM is a vehicle for a learning organisation (Figure 4.3) (Hafeez *et al.*, 1998). Organisations have to translate “continuous improvement” into “continuous learning” through “dynamic system-wide” performance (Senge, 1994a). It involves sharing knowledge across the organisation, adapting a systems approach for problem solving, mastering new ways of thinking, and updating and refreshing the organisation memory.

Amrik (1995) examine three organisations that successfully adopted the TQM philosophy to determine the link between TQM and learning organisations. The three organisations are Toyota Motor Corporation, Ramset Fasteners Limited and W.A. Deutscher Metal Products Group – all located in Melbourne, Australia. The result has

been greater focus on both extensive training and employee involvement. Learning is clearly an output of a successfully implemented TQM programme and a TQM initiative can only be regarded as successful when a new working environment has been created in which people are able to learn, share knowledge and make contributions. Unfortunately, most TQM efforts never reach the stage where people's behaviours have been modified, and new working arrangements and culture are established.

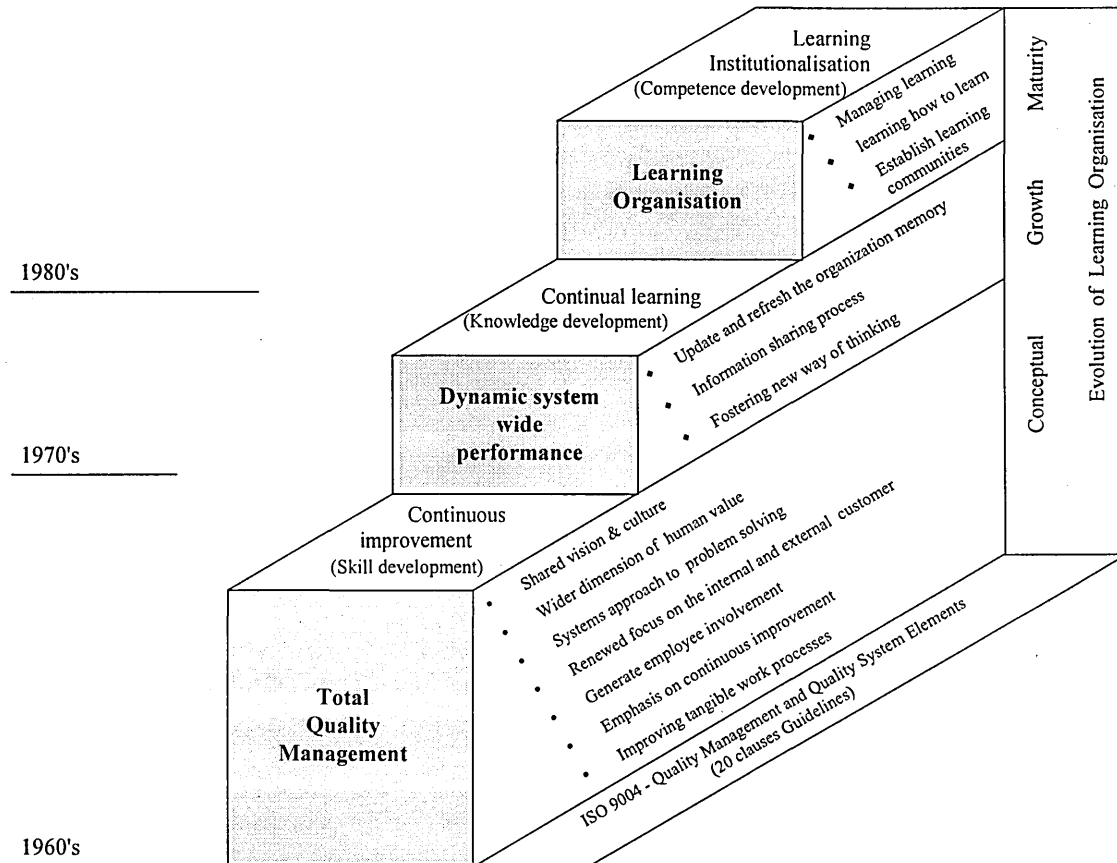

Figure 4.3: Evolution of learning organisation

4.6 Key elements of the framework

The framework consists of twenty-eight elements, which are categorised under the well-established operations research dimensions of technologies and tools, organisation and system, and people. Nineteen endogenous dependent outcomes has also been identified and grouped under, non-financial and financial performance categories. Figure 4.4 enlists these elements, and a description of each factor/ variables and potential relationships is described in the following sections.

In the present author's view, people are an integral element of the all three waves of quality. However these elements would have different weightings for the each wave of quality. This is also true for most of the organisation (system) elements.

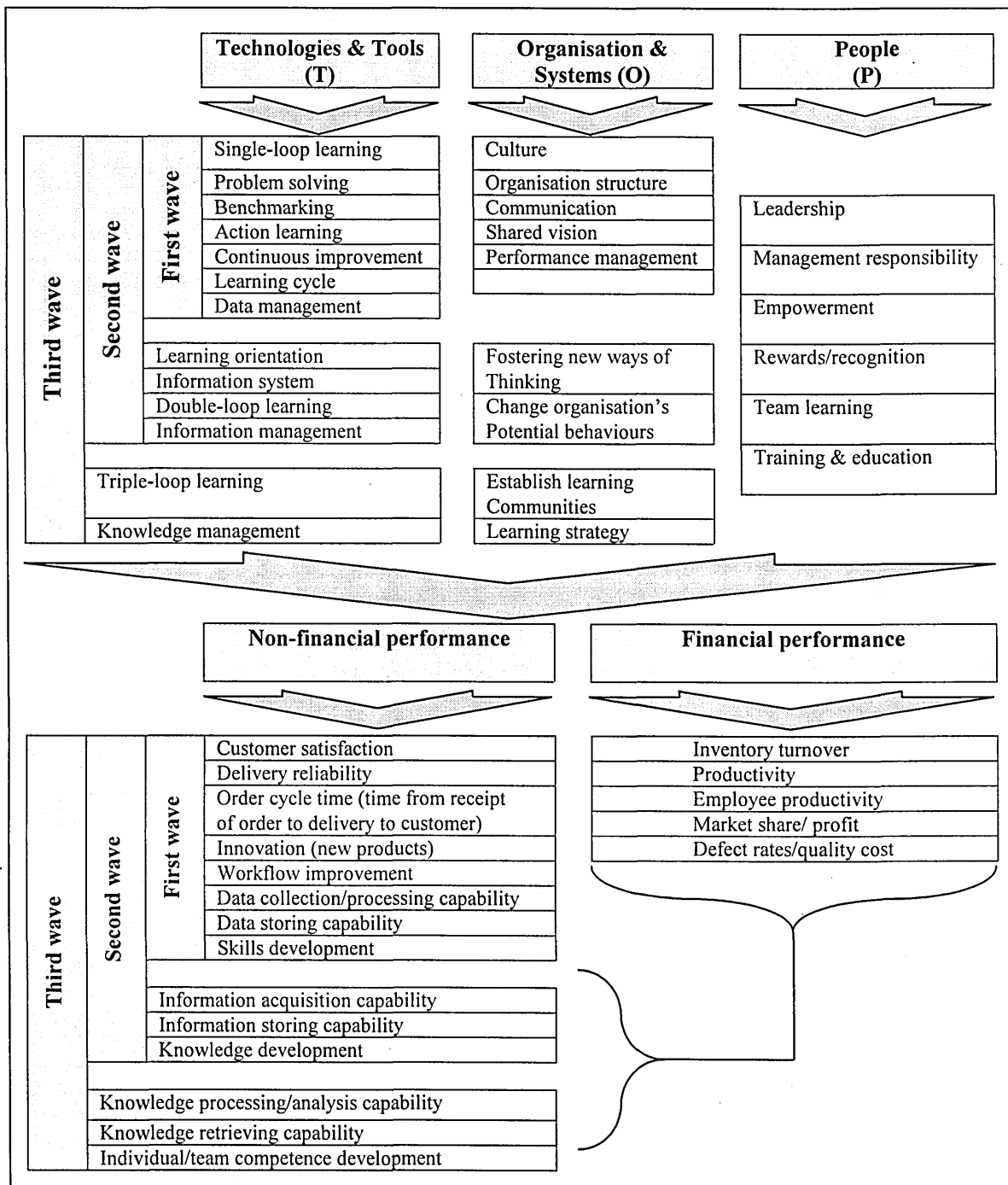

Figure 4.4: The conceptual framework for a learning organisation.

The first wave organisation is an organisation, which uses essential learning tools such as, single-loop learning, problem solving, benchmarking, action learning, continuous improvement and/or learning cycle. The main emphasis here is data collection and analysis and to develop the skill of detecting and correcting the errors. In this situation

learning decisions are largely based on observations. This has the consequence that no renewal is taking place since the goal is to optimise an already established process or method.

A second wave organisation, in addition to detection and correction of error, question and modify the existing procedures, policies, and objectives (i.e. double-loop learning). Second wave involves changing the organisation's knowledge base by challenging the existing norms and routines. This wave is about double-loop learning where the organisation discovers that the identification of a problem or gap in itself depends on learning new ways of perceiving and thinking about the problem itself (Argyris and Schon, 1978).

On the other hand the third wave is about triple-loop learning, that is, how to carry out single-loop and double-loop learning. This wave is a must when the existing knowledge is no longer adequate in order to reach the objectives. This implies a complete change and renewal, requiring the individual to reflect on their mental models and for organisations to induce new culture and structures.

A framework is of little use unless there are clear milestones and measuring procedures. The present author believes that the 21st century organisations cannot solely rely on quantifiable measures such as cost and schedule performance, while ignoring qualitative measures such as customer satisfaction and innovation. Therefore two sets of performance measures are introduced to evaluate the organisation performance. The first set is concerned with non-financial measures. The second set targets financial measures as shown in Figure 4.4. The whole framework may be viewed under enablers and results as often advocated by EFQM (EFQM, 1999).

These measures are linked to the three waves of quality. The main emphasis of the first wave measures concerns data collection and skill development. The second wave measures are concerned with quantifying the organisation memory capacity and knowledge development capability. Whereas, the third wave is about the strategic use of this knowledge for future products and services. The main focus of the measuring process is diverted from skills and knowledge development of individuals to organisation competence development (Prahalad & Hamel, 1990).

4.6.1 Technologies and tools elements

This section explains the technology and tools elements of the framework for the first, second or third wave movements. Technology, by definition is a combination of technical expertise (*technos*) and knowledge bases (*logos*), has become a key element in the modern theory of learning organisation (Guillermo, 1999). This is due to the actual trend to focus on the cognitive component of technology in detriment to its technical parts. Accordingly, innovation processes, which traditionally were tied to technical aspects of new product development and were considered a linear sequence of related activities in the domains of science, technical research and commercialisation, are currently being considered processes that integrate information flows and bases of knowledge created within and externally to the boundaries of the organisation. Since knowledge is the cornerstone of learning organisation, quality innovation and learning process are tightly linked. More details of these elements are to be found in Appendix 4.1.

4.6.2 Organisation and systems elements

The elements under this categories refers to the formal organisational structure, culture, communication, performance management, fostering new ways of thinking, change organisation's potential behaviour, establish learning communities, shared vision and learning strategy. The organisation systems can be defined as the rules, procedures, guidelines and instruments with which the daily functioning of people in the organisation is facilitated. More details of these elements are to be found in Appendix 4.1.

4.6.3 People

As shown in Figure 4.4 the people element is common to all three waves of quality. However the nature and emphasis of these elements would have a different degree of weighting (involvement) for the each wave of quality. More details of these elements are to be found in Appendix 4.1.

4.6.4 Organisational performance

Organisation hoping to become learning organisations cannot rely exclusively on the traditional measures such as cost and schedule performance, while ignoring learning that affects other variables such as quality and new product developments. Hultink and

Robben (1995) concluded that performance measurements impact on an organisation by shaping the behaviour of managers and employees alike. For example, the Apple Computer case, Kaplan and Norton (1993) found that measures which include financial as well as customer, innovation and learning perspectives, had benefited executives more than the pure financial measurement. Therefore two sets of performance measurements are identified to evaluate the output performance. The first set is concerned with quantifying non-financial performance. The other set include a financial factors as shown in Figure 4.4. A description of the financial and non-financial measure specific to the first wave, second wave and third wave are given in appendix 4.1.

4.7 Summary

This Chapter offered a historical account of the evolution of TQM. It has identified eighteen essential factors contributed to total quality management. Also, this Chapter delivered a survey of ten most notable authors in the learning organisation field in a tabular form (Table 4.2), where various subjective weightings are assigned identifying learning characteristics. This is to help organisations see the learning organisation elements and systems benchmarked in a compact format. Further a relationship between TQM and organisation learning is established in the form of learning flywheel (Figure 4.2), and transformation from TQM to learning organisation is described in a step-by-step procedure (Figure 4.3).

The enablers-results mechanism of European Foundation for Quality Management (EFQM) (EFQM, 1999) is adapted to construct the learning organisation framework. The framework consists of twenty-eight elements, which are categorised under the well-established operations research dimensions of Technologies and tools (**T**), Organisation and system (**O**), and People (**P**). Nineteen endogenous dependent outcomes have also been identified and grouped under, non-financial and financial performance categories. These elements are enlists, and a description of each factor/variable and potential relationships are provided. This Chapter lays out the framework for illustrating the link between the total quality management (first wave), dynamic system wide performance (second wave) and organisational learning (third wave). The relationships between training, skills, knowledge and competence developments are the main ingredients in the learning processes, which are equivalent to the three waves of quality.

In the next Chapter the framework is implemented in practice by means of a questionnaire survey for both manufacturing and non-manufacturing organisations and is used to validate the three waves of quality, through analysis of the collected data. Also, in the next Chapter, some important research findings is summarised and presented

4.8 References

- Amrik S. and Michael M., (1995), "Is there a link – total quality management and learning organisations?", *The TQM Magazine*, Vol. 7, No. 3, PP. 41–44
- Argyris, C. and Schon, D., (1978), "Organisational Learning: A Theory of Action Perspective", Addison Wesley, Reading, MA.
- Argyris, C. and Schon, D., (1996), "Organisational Learning II: Theory, Method and Practice", Addison Wesley, Reading, MA.
- Barrow, J. W., (1993), "Does total quality management equal organisational learning?", *Quality Progress*, July, pp.39-43
- Chobadian & Speller, (1994), "Gurus of quality: A framework for comparison", *Journal of total quality management*, Vol. 5, No. 3, pp. 53 - 69.
- Crosby, P., (1979), "Quality is free", Mc Graw - Hill, New York
- Dague, D. C., (1981), "Quality Historical Perspective, Quality Control in Manufacturing", *Proceedings of the Society of Automotive Engineering's*, February
- Deming, W.E., (1986) "Out of the Crisis", MIT Centre for Advanced Engineering Study, Cambridge, MA
- Dixon, Nancy, (1993), "Organisational Learning." Ottawa; Conference Board of Canada Report 111-93.
- Dodgson, M., (1993), "Organisational learning: A review of some literatures". *Organisation Studies*, Vol. 14, No. 3, pp. 375-394.
- EFQM, (1999), "The EFQM Excellence Model", Public and Voluntary Sector, The European Foundation for Quality Management, Brussels
- Feigenbaum, (1991), "Total Quality Control (3rd edition)", Mc Graw-Hill, New York
- Fiol, C., & Lyles, M., (1985), "Organisational learning" *Academy of Management Review*, No. 10, pp. 803-813
- Garvin, D., (1993), "Building a learning organisation", *Harvard Business Review*, July-August, pp. 78-91.

- Guillermo Perez-Bustamante, (1999), "Knowledge management in agile innovative organisations", *Journal of Knowledge Management*, Vol. 3, No. 1, pp. 6-17
- Hafeez K., Abdelmeguid H., and E. K. Lo., (1997), "Learning in virtual supply chains", 3rd Anthropocentric Lean Production Systems (ALPS) Conf. Free University, Belgium.
- Hafeez K., Abdelmeguid H., and E. K. Lo., (1998), "Establishing a learning culture in transnational supply chains", Workshop on International Operations, Aston University, 31st March. 26
- Hultink, E. J. and Robben, H. S. J., (1995), "Measuring new product success: the difference that time perspective makes", *Journal of Product & Innovation Management*, Vol. 12, No. 5, PP. 392-406.
- Huber, G. P., (1991), "Organisational learning: the contributing processes and the literatures", *Organisation Science*, Vol. 2 No. 1, pp. 88-115.
- Ishikawa K., (1990), "Introduction to Quality Control", London, Chapman and Hall.
- Joiner, B. L., (1990), "Continuous improvement: Putting the pieces together", The quality management forum (ASQC's quality management division newsletter), Vol. 14, No. 2, May, pp. 1
- Juran J. M., (1988), "Quality Control Hand book", Mc Graw - Hill
- Kanji, G., (1990), " Total Quality Management, The second Industrial Revolution", *Total Quality Management*, Vol. 1, No. 1, pp. 3-21.
- Kaplan, R. S. and Norton, D. P., (1993), "Putting the balanced scorecard to work", *Harvard Business Review*, Vol. 71, September /October, PP. 134-43.
- Luthans, F., Rubach, M. and Marsnik, P., (1995), "Going beyond total quality: the characteristics, techniques and measures of learning organisations", *International Journal of Organisational Analysis*, Vol. 3 No. 1, January, pp. 24-44.
- Mason, R. M., (1993), "Strategic information systems: Use of information technology in a learning organisation", *Proceedings of the twenty-sixth Hawaii International Conference on System Sciences '93 s 24*, CA: IEEE Press, 840-849.
- Mellor C., (1987), "Personal quality", TMIALS
- Morgan, G., (1986), "Images of organisation", Sage Newbury Park, CA
- Nevis, E. C., DiBella, A. J. and Gould, J. M., (1995), "Understanding organisations as learning systems", *Sloan Management Review*, Vol. 36 No. 2, pp. 73-85
- Oakland, J, S., (1993), "Total quality management - The route to improving performance", Butterworth - Heinemann.

- Prahalad, C.K. and Hamel, Gary, (1990), "The core competence of the corporation", Harvard Business Review, May-June, pp. 79-91
- Senge, Peter, M. (1994a), "The Fifth Discipline Field book: Strategies and Tools for Building a Learning Organisation", New York: Doubleday.
- Senge, P., (1994b), "Building learning organisations", H. Costin, editor, Reading in Total Quality Management (Fort Worth. TX: The Dryden press), pp. 60-67.
- Senge, P. (1995), "The message of the quality movement", Journal of Executive Excellence, Vol. 12 Part 7, pp. 5-6
- Sitkin, S., Sutcliffe, K. and Schroeder, R., (1994), "Distinguishing control from learning in total quality management: a contingency perspective", Academy of Management Review, Vol. 19 No. 3, pp. 537-64.
- Taguchi, (1996), "The Taguchi approach to parameter design", ASQC quality congress transaction, Anaheim
- Watkins, K. and Golembiewski, R., (1995), "Rethinking organisational development for the learning organisation", International Journal of Organisational Analysis, Vol. 3 No. 1, January, pp. 86-101

CHAPTER 5

IMPLEMENTING AN ORGANISATIONAL LEARNING FRAMEWORK THROUGH QUESTIONNAIRE SURVEY

5.1 Introduction

Using the conceptual framework discussed in Chapter 4, a questionnaire survey was conducted to review the state of the total quality movement in the European organisations. The sample consists of manufacturing, service and public sectors organisation. This Chapter presents some important research findings through analysis of the collected data. Three case studies have been used for validating the conceptual framework through studying and analysing the enablers and results. Also, this Chapter reports the impact of the learning activities on the organisational performance by using the combination of case study and questionnaire survey study.

5.2 Survey design

The questionnaire is conducted with the view to be easy to implement. Therefore, the questionnaire is designed in a simple and compact form as far as possible aiming at obtaining high response rate. Based on Chapter 4 the conceptual framework consists of twenty-eight elements (enablers), and nineteen dependent outcomes (results). Therefore, the structure and terminology of the questionnaire are considered carefully aiming to elicit the accurate information from the practitioners.

A weights and scores technique is very often realized using a Likert-style scale. The most often used are five-points or seven-points scales. A 5-points scale is able to elicit sufficient information as well as simplify the process of data collection. In order to discourage the respondents to take a neutral stand, a six-point scale is selected. Therefore, the key capabilities is evaluated on a six-point scale where not applicable = N/A, no progress = 0.00, some progress = 0.25, satisfactory = 0.50, good progress = 0.75 and achieved = 1.00. Since no middle point is involved, the scale could help to reduce the opportunity of taking neutral stance by the respondents, so the response quality would improve.

5.2.1 Pilot study

A group of twenty-organisation sample were conducted to reveal the strengths and weaknesses of the initial questionnaire in terms of its ability to collect the relevant data. The organisations were selected from the CBI-UK Kompass (1998) to represent large and small UK organisations. Ten of the organisations were manufacturing and the others were service organisations. The main purpose taking the equal numbers for the selection was to secure responses from the both manufacturing and non-manufacturing sectors, and to examine the appropriateness of the contents and expression for the both sectors. The following aspects of the questionnaire design were focused during the pilot study: -

- Its overall appearance
- The instructions to respondents
- The contents of questions
- Timescale needed to complete
- Their reservations on the concepts used

The questionnaires were sent to the selected organisations by post and a covering letter was enclosed explaining the purpose. A total of four organisations, three manufacturing and one non-manufacturing, responded and completed the questionnaire. This process was repeated for four times by sending questionnaire to another organisations sample. The number of respondents and completed questionnaire was varying each time. The results from the pilot study were hopeful.

However, some shortcomings of the initial questionnaires were revealed. For example, the words used in some technical terms, e.g., learning loops/process, learning cycle, fostering new ways of thinking, and organisation potential behaviour needed more clarification. Even some basic terms such as problem solving and benchmarking were questioned. Therefore specific explanations were incorporated to main body of the question to enhance understanding. Based on these findings, the questionnaire was modified and finalised. Appendix 5.1 presents the covering letter and the finalised questionnaire for convenience.

5.2.2 Survey structure

The questionnaire comprises four sections. Section one of the questionnaire was to evaluate the technologies and tools elements as the learning organisation characteristics. Section two was to evaluate the support of the organisation structure and processes for the purpose of learning. Section three was aimed to identify the continuous improvement/learning process/advanced technology programme implemented in the organisation and measure the effect of these strategies on the organisation performance. The organisation profiles i.e. number of employees, organisation size, and the estimated annual sales were collected in section four.

Each element of the framework was translated in the form of a Likert-scale/linear scale question (Likert, 1952; Hague, 1993; Denscombe, 1993). Respondents were asked to provide a subjective assessment to these. The correlation between the conceptual framework elements and the relevant questions presented in the questionnaire are shown in Table 5.1.

5.3 Organisations profile and classifications

The questionnaire was sent to over one hundred European organisations that had shown an interest in the research. The questionnaires are self-administered. 65% of the questionnaires were conducted by face-to face contact by attending two workshops, Cambridge (UK) and Bari (Italy). However 35% were postal questionnaires by using the CBI-UK Kompass source. Again, pilot study was conducted to identify the organisations that have an interest, which are implemented or have a business strategy in place more than three years. Furthermore, through case study the major data were collected by interviewing who interested in the results.

For the mail survey, the questionnaire with the covering letter was sent to the R&D department of the selected organisations. The R&D in turn distributes the questionnaires to who interested or the best-suited individual to fill it in. The organisations were asked to return the completed questionnaire using the provided pre-paid envelope. After three weeks time, a revised covering letter and a second copy of the questionnaires were sent to those non-respondents to remind them for completion.

		The framework elements	The relevant questions presented in the questionnaire	
Enablers	Technologies (Tools)	Single-loop learning	The organisation understands the process by which individuals/teams learn.	
		Double-loop learning	Individuals and teams have an easy access to the information relevant to their area of responsibility	
		Triple-loop learning		
		Problem solving	A data collection mechanism for decision-making and problem solving is in place.	
		Benchmarking	The organisation is continuously evaluating the work processes against an industry leader.	
		Action learning	The employee know how to learn from mistakes	
		Continuous improvement	Continuous improvement	
		Learning cycle	The organisation is continuously introducing advanced technologies	
		Learning orientation	The organisation has developed a model to facilitate learning process.	
		Information system	Information system	
		Data management		
		Information management		
		Knowledge management		
		Organisation (systems)	Culture	Culture
	Organisation structure		Organisation structure	
	Communication		Communication	
	Shared vision		Shared vision/strategy	
	Learning strategy			
	Performance management		Performance management	
	Fostering new ways of thinking		The organisation understands the process by which individuals/teams learn.	
	Change organisation's Potential behaviours		The organisation is continuously introducing advanced technologies The organisation understands the process by which individuals/teams learn.	
	Establish learning Communities	Individuals and teams have an easy access to the information relevant to their area of responsibility		
	People	Leadership	Leadership	
		Management responsibility	Management responsibility	
		Empowerment	Empowerment	
		Rewards/recognition	Rewards/recognition	
		Team learning	Individual/team development	
		Training & education	The organisation has developed a model to facilitate learning process. Individual/team development	
	Results	Financial performance	Inventory turnover	Inventory turnover
			Productivity	Productivity
Employee productivity			Employee productivity	
Market share/ profit			Market share	
Defect rates/quality cost			Defect rates	
Non-financial performance		Customer satisfaction	Customer satisfaction	
		Delivery reliability	Delivery reliability	
		Order cycle time (time from receipt of order to delivery to customer)	Order cycle time (time from receipt of order to delivery to customer)	
		Innovation (new products)	Innovation (new products)	
		Workflow improvement	Workflow improvement	
		Data collection/processing capability	Knowledge collection / acquisition capability	
		Data storing capability		
		Information acquisition capability		
		Information storing capability	Knowledge storing capability	
		Knowledge processing/analysis capability	Knowledge processing / analysis capability	
		Knowledge retrieving capability	Knowledge retrieving capability.	
		Skills development	Information sharing process	
		Knowledge development	Individual competence development	
Individual/team competence development				

Table 5.1: The correlation between the conceptual framework elements and the relevant questions presented in the questionnaire

A total of thirty-six questionnaires were completed and returned (36% response rate). In many cases, the responding organisations are in the process of developing or implementing TQM, organisational learning and knowledge management strategies and projects. As such, these organisations are a representative of organisations attempting to transform themselves into learning organisation. Of the businesses surveyed, 47% were manufacturing, 14% were public sector, and 39% classified themselves as service organisations as shown in Figure 5.1.

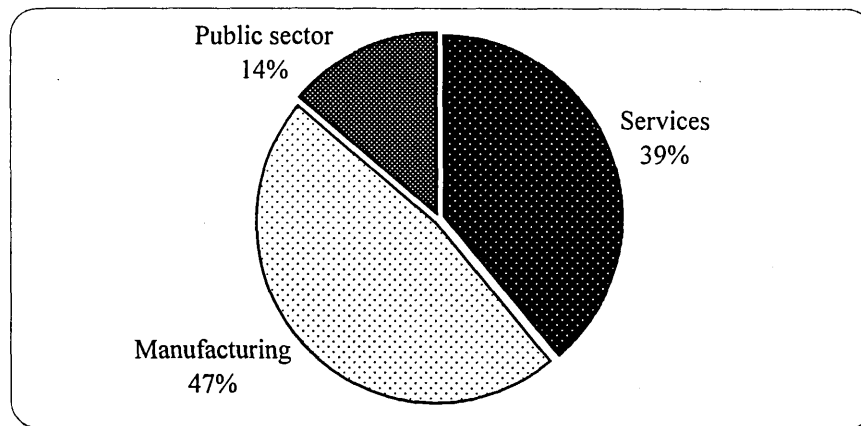

Figure 5.1: Respondents by industry/sector

It should be noted that the selected organisations had some business improvement strategies/programmes in place at least during the last three years as shown in Figure 5.2. The results in Figure 5.3 show that 31% of the respondent organisations were implementing a total quality management programme. 27% of the organisations reported using, a knowledge management programme. A large proportion of organisations were the implementing or planning to implement organisational learning programme (42%). These statistics reflect that a high proportion of the organisations in the survey are using methods attempting to promote a learning culture. As such, these organisations are a representative of organisations attempting to transform themselves into learning organisation.

Figure 5.4 shows that 31% of the sample represents larger organisations (over 500 employee). Organisational size was almost evenly split with 46% of the organisations employing more than 500 people, and 54% with less than 500 employees. The size of the business surveyed was also very wide ranging. For example: 58% of the surveyed organisations had annual revenues/budgets of more than £50 million, 42% revenue annually less than £50 million as shown in Figure 5.5.

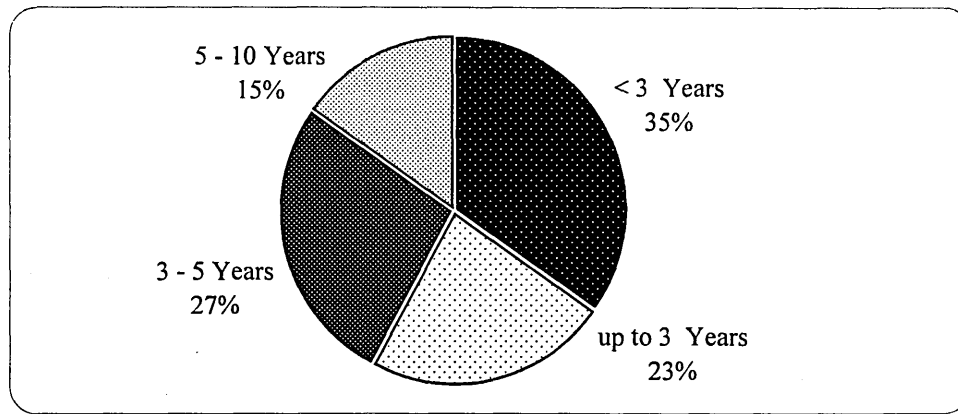

Figure 5.2: Implementation period profile of the respondent organisations

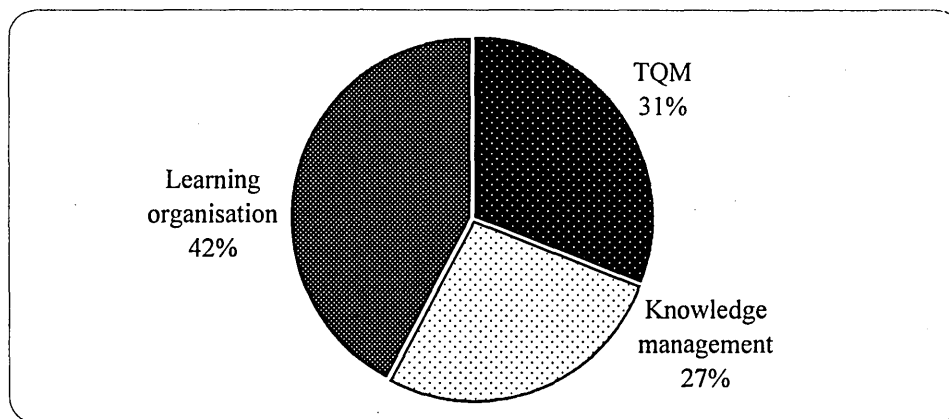

Figure 5.3: The continuous improvement strategy profile of the respondent organisations

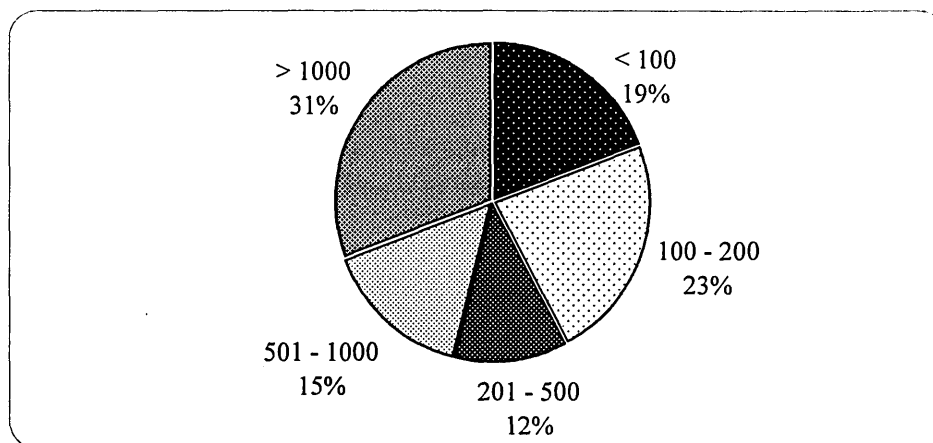

Figure 5.4: Employee profile of the respondent organisations

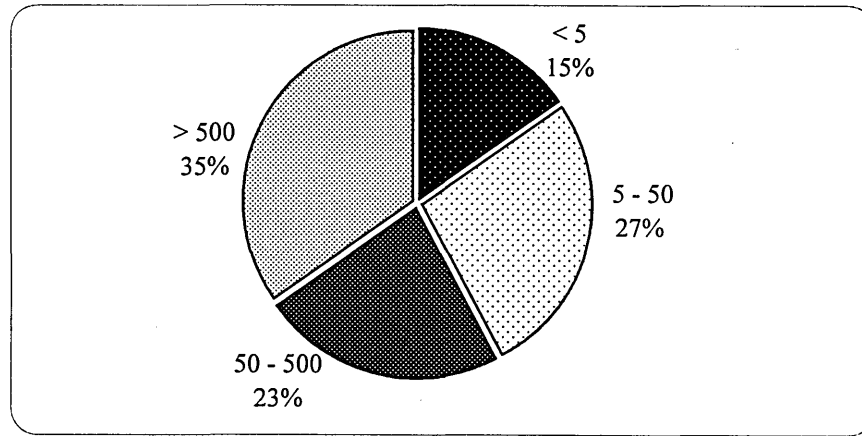

Figure 5.5: Sales profile of the respondent organisations

5.4 Survey analysis

The survey analysis was carried out to identify which milestone a particular organisation has reached in their journey on the route of quality movement. Both enablers as well as the performance measures scores were analysed. The fundamental standpoint for this thesis is that organisational learning is critical to organisation success. There were several questions asked regarding current organisational learning tools and the potential for technologies to assist organisations, in their transformations. To continue this line of enquiry the three waves of quality were explored through a series of questions under the heading of technologies and tools (T), organisation and systems (O), and people (P). The survey was asked how effective of T, O, and P within organisations.

Each sample responses were summed and averaged under T, O, and P category. If respondent gives a value zero to the second wave and third wave elements, obviously that particular organisation belongs to the first wave organisation. In case a respondent gives some weight to the second and third wave elements, however the average score for category T, O, and P, respectively, is ≤ 0.33 , the organisation is categorised as the first wave organisation. Similar rules were developed to identify if an organisation belongs to the second wave or the third wave. For example if the average value for the T, O, and P lies in between 0.33 and 0.66, the organisation is in the second wave. If respectively, the average T, O, and P scores are > 0.66 , the organisation is in the third wave.

Table 5.2 illustrates the correlation between the conceptual framework elements and the relevant enablers and results, which are used in the following analysis. An initial analysis of the questionnaires revealed that ten out of the thirty six returned questionnaires were either not completed or had some contradict information, therefore they were excluded from the analysis. More details of these ten organisations are to be found in Appendix 5.2. A total of twenty-six questionnaires are used in the final analysis. As shown in Figure 5.6, a total of six respondents (23%) stated that their organisations were developing TQM, as a baseline for the organisational learning. However, according to the above rules, nine (35%) organisations were in the first wave. Seventeen (65%) out of twenty organisations (77%) were in the early stages of rolling out programmes and initiatives to support their organisation learning strategies. Of these seventeen organisations, thirteen (50%) were in the second wave of quality where they have implemented a dynamic organisation wide performance system. On the other hand only four organisations (15%), were actively introducing all of the organisational learning activities as listed in the conceptual model. The organisations were classified, as the first wave, second wave and third wave are the bases of the analysis of the questionnaire responses.

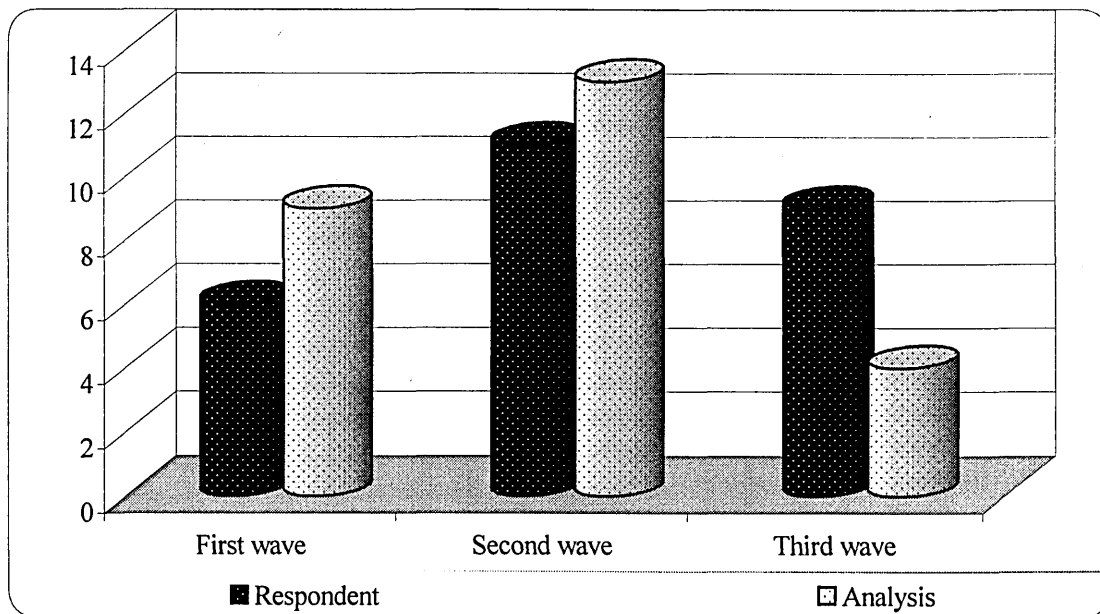

Figure 5.6: A comparison of self-perception against framework analysis

		The framework elements	The relevant elements presented in the analysis
Enablers	Technologies (Tools)	Single-loop learning	Learning loops/process
		Double-loop learning	
		Triple-loop learning	
		Problem solving	Problem solving
		Benchmarking	Benchmarking
		Action learning	Action learning
		Continuous improvement	Continuous improvement
		Learning cycle	Learning cycle
		Learning orientation	Learning orientation
		Information system	Information system
		Data management	
		Information management	
		Knowledge management	
		Organisation (systems)	Culture
	Organisation structure		Organisation structure
	Communication		Communication
	Shared vision		Shared vision/learning Strategy
	Learning strategy		
	Performance management		Performance management
	Fostering new ways of thinking		Fostering new ways of thinking
	Change organisation's Potential behaviours		Potential behaviour
	Establish learning Communities	Learning communities	
	People	Leadership	Leadership
		Management responsibility	Management responsibility
		Empowerment	Empowerment
		Rewards/recognition	Rewards/recognition
		Team learning	Team learning
Training & education		Training and education	
Results	Financial performance	Inventory turnover	Inventory turnover
		Productivity	Productivity
		Employee productivity	Employee productivity
		Market share/ profit	Market share
		Defect rates/quality cost	Reduce defect rates
	Non-financial performance	Customer satisfaction	Customer satisfaction
		Delivery reliability	Delivery reliability
		Order cycle time (time from receipt of order to delivery to customer)	Order cycle time
		Innovation (new products)	Innovation (new products)
		Workflow improvement	Workflow improvement
		Data collection/processing capability	Knowledge acquisition capability
		Data storing capability	
		Information acquisition capability	Knowledge storing capability
		Information storing capability	
		Knowledge processing/analysis capability	Knowledge processing
		Knowledge retrieving capability	Knowledge retrieving capability
		Skills development	Information sharing process
		Knowledge development	Individual competence development
		Individual/team competence development	

Table 5.2: Correlation between the framework elements and the relevant elements presented analysis

5.5 The framework validation

Three organisations were invited to validate the conceptual framework via review and analysis of the enablers and results. The organisations included in this case study analysis were selected on the basis of their relation to quality waves (i.e. organisations A, B and C are first, second and third wave respectively). Representatives from organisations A, B, and C intimated that most organisation failing to grasp the basic truth that TQM requires a commitment to learning, and their competitive advantage lay in the best use of their internal resources to realise this aim. The values of T, O, and P and organisation performance for all respondents are presented individually.

The second level of analysis was to evaluate the impact of these learning activates on the organisational performance. Respondents were asked to indicate which of the financial or non-financial measures they employ to evaluate its success objectives. The pattern of financial and non-financial organisational performance for the three organisations case studies A, B, and C respectively were illustrated.

5.5.1 The first wave organisations

As noted above, 35% of the respondents worked in total quality management (first wave). The framework mentioned in the previous Chapter summaries the questions related to the first wave as single-loop learning, data management and skill development through training to detect and correct the errors.

5.5.1.1 Case organisation A

The organisation A has implemented TQM as a business strategy during last three years. It has less than 500 employees and has the sale turnover in the range of £ 5-50 m/year in the last financial year. As shown in Figure 5.7 organisation A reported that, team learning, management responsibility, learning communities, fostering new ways of thinking, learning cycle, information system, and learning orientation have scored either no ratings or very low with regards to the framework enablers. However, training and education empowerment, communication, continuous improvement, and problem solving have scored relatively high ratings. Rewards/recognition, leadership, performance management, potential behaviours, shared vision/learning strategy, organisation structure, culture, benchmarking and action learning have scored relatively the medium ratings.

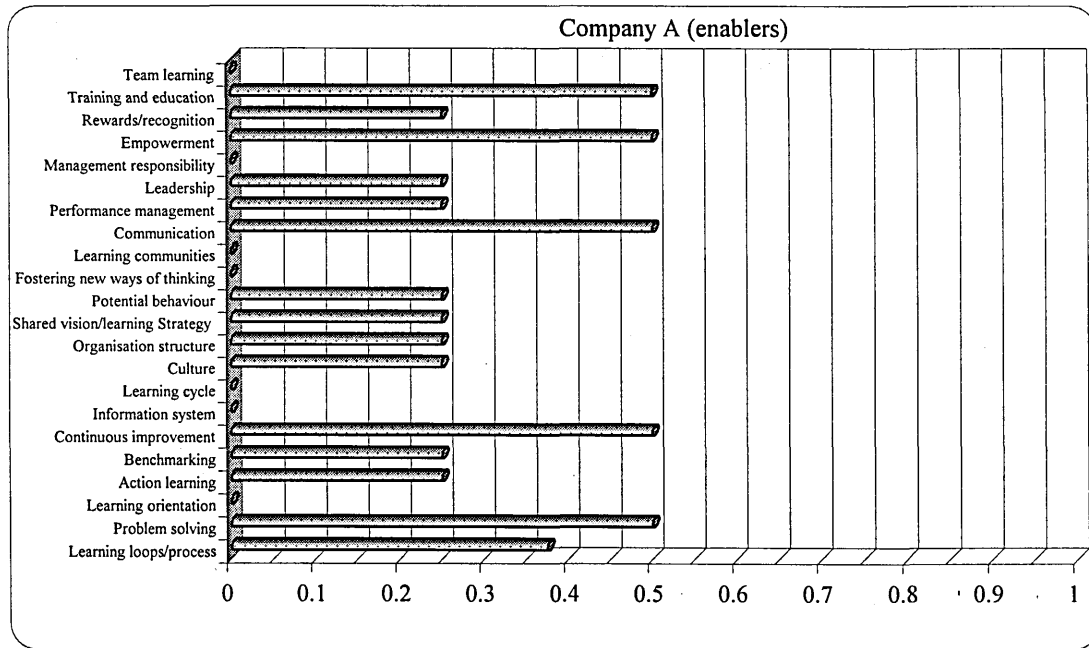

Figure 5.7: The values of enablers for the first wave case study

Where as, leadership (25%) takes responsibility for developing individual training and education, empowerment and continuous improvement are strongly emphasised. The organisation A tendency to organise is also matched by its capacity to facilitate problem solving (50%). In total quality management the focus on analytical tools and systems based methods tends to foster the single-loop learning response. Organisation A should be built in, or inherent, learning loops/processes and the other elements, training and education, should support this and therefore fall into place.

As explained in section 5.4, the framework elements were summed and averaged under the technologies and tools, organisation and systems, and people category. Organisation A scored 0.23, 0.22, and 0.25 respectively for T, O, and P as shown in Figure 5.8. Note that the values of T, O, and P are less than 0.33 and therefore according to the set criteria organisation A is the first wave organisations.

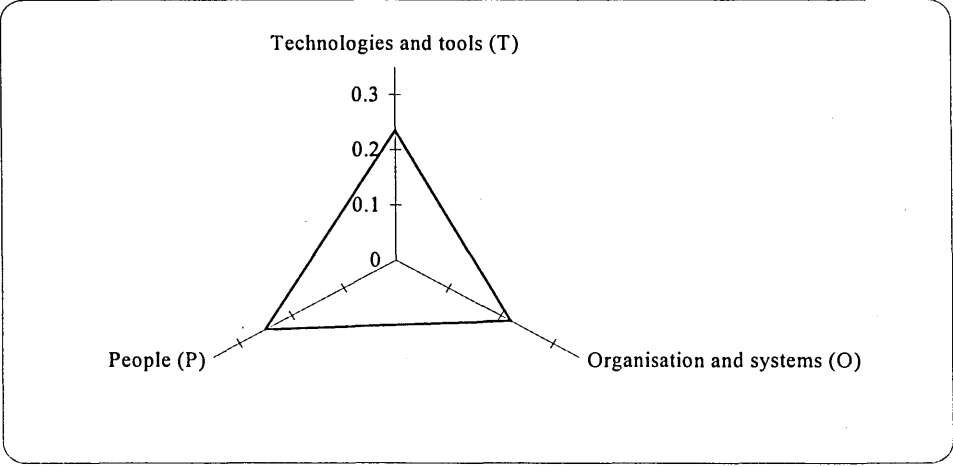

Figure 5.8: The average values of T, O, and P (enablers) for the first wave case study

Figure 5.9 illustrates that the organisation performance with respects to defect rates, productivity, inventory turnover, innovation and delivery reliability each scored about 25%. Also organisation A reported no score for all the information sharing processes and knowledge management elements. This is supported by the enabler’s analysis, as the information systems elements scored a zero value.

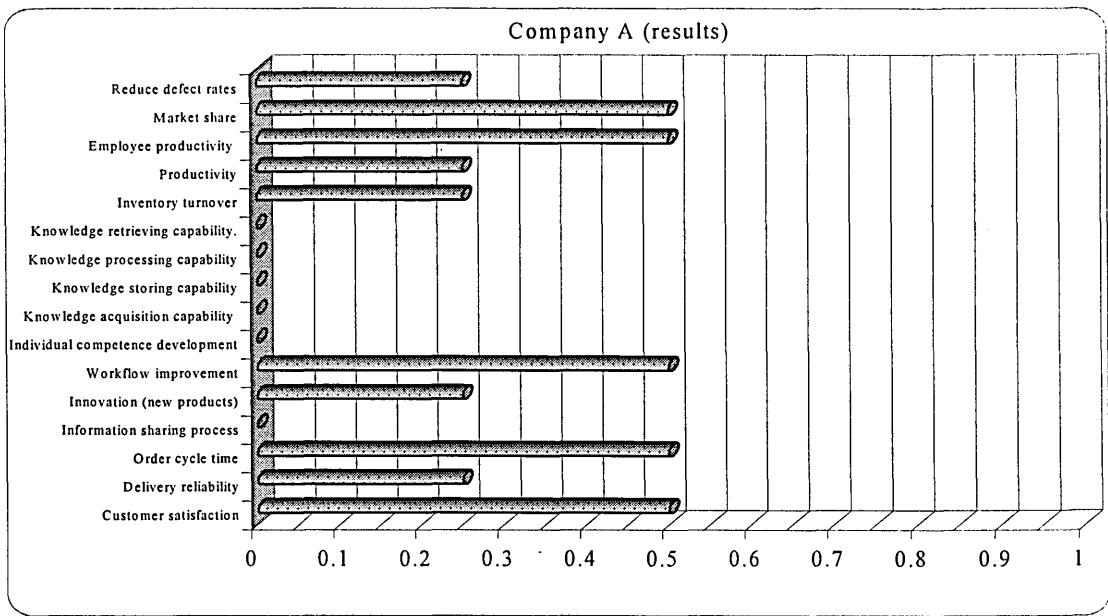

Figure 5.9: The values of organisational performance (results) for the first wave case study

Elements such as Customer satisfaction, order cycle time, workflow improvement, employee productivity and market share scored 50%, which is relatively high at this wave. This support the value that why total quality management emphasises on the customers resources. Clearly the organisation performance measures related to

information sharing processes and knowledge and individual/team competence scored minimum or no ratings at all.

Figure 5.10 illustrates that non-financial and financial performance on average scored 0.18 and 0.35 respectively. This means that organisation A emphasised relatively more on the quantifiable or traditional measures.

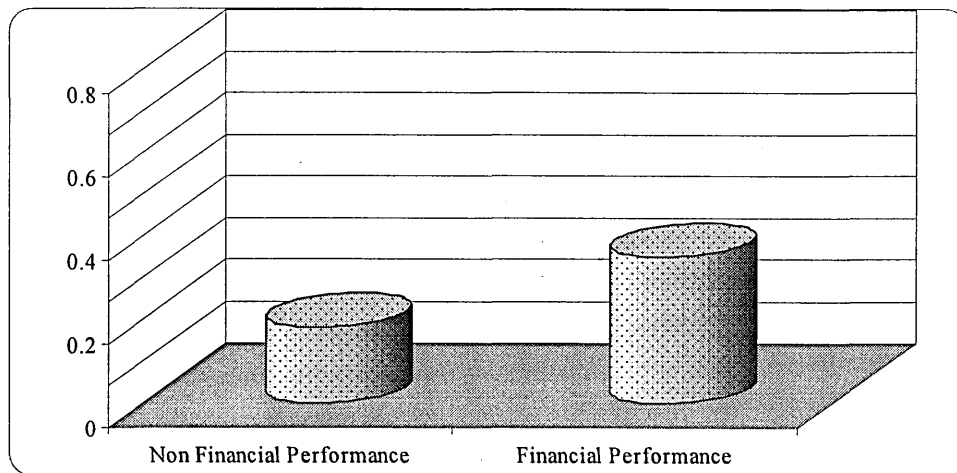

Figure 5.10: The average values of financial and non-financial performance for the first wave case study

5.5.1.2 Survey results for first wave organisations

The method as described in section 5.5.1.1 was adopted for each individual organisation. Using the T, O, and P rules as described above, the first wave organisations were identified. Figure 5.11 illustrated the average sum of T, O, and P elements and corresponding organisation performance averaged under financial and non-financial measures. Figure 5.11 illustrates the individual results of the nine organisations identified as the first wave organisation averaged under T, O, and P enablers with corresponding non-financial and financial performance results. It is clearly demonstrated that T, O, and P dimension has scored under 0.33 in each case. It was not possible to show a direct correlation between the enablers and results. However each radar plot may be viewed as a rough-cut percentage indication of the amount of T, O, and P resources/efforts applied by each organisation. Also for each case in this category financial performance measures clearly outweighs the non-financial measures. As mentioned earlier there are implicit relationships between non-financial and financial performance measures.

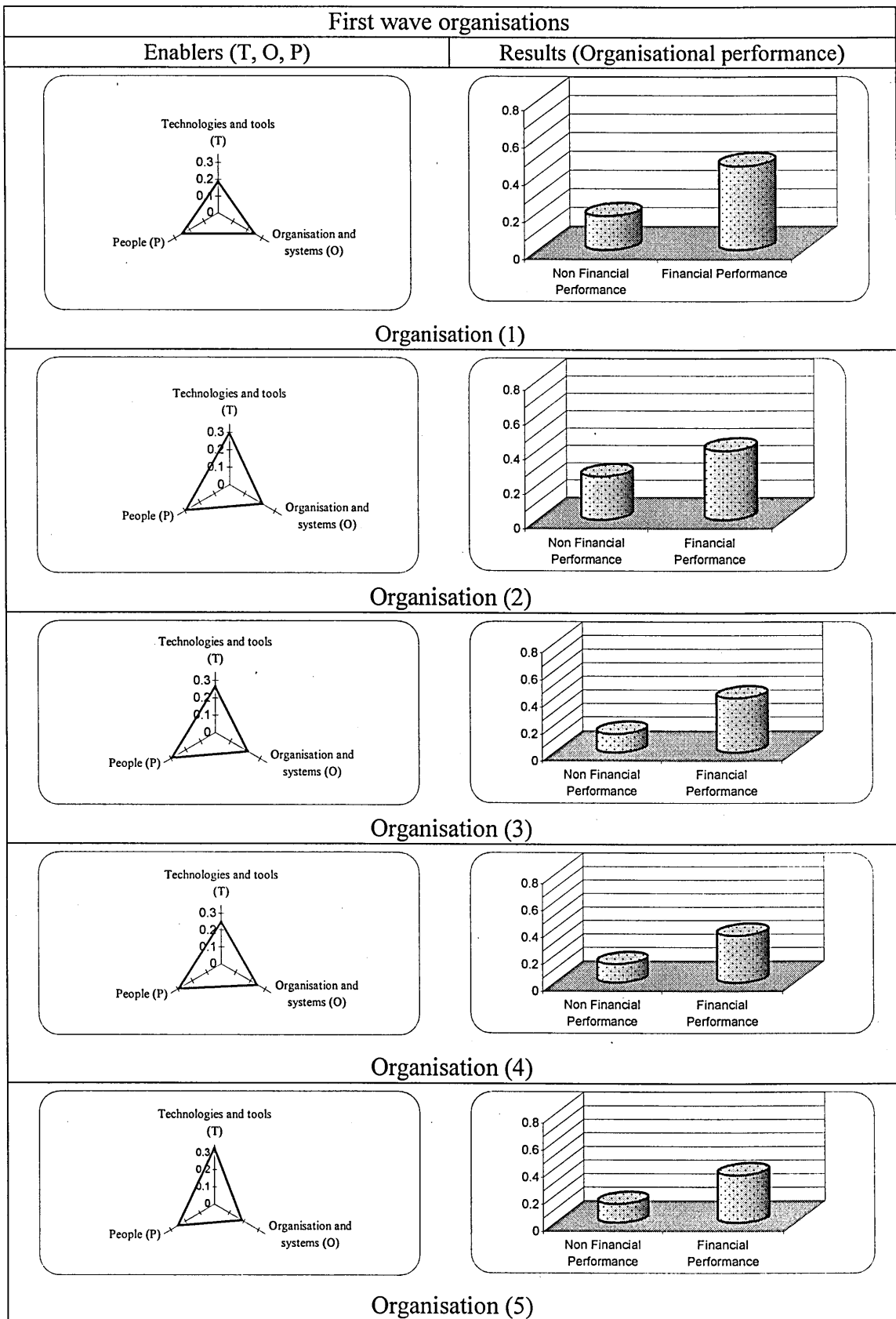

Figure 5.11: The average values of T, O, and P (enablers) and organisational performance (results) for the first wave organisations

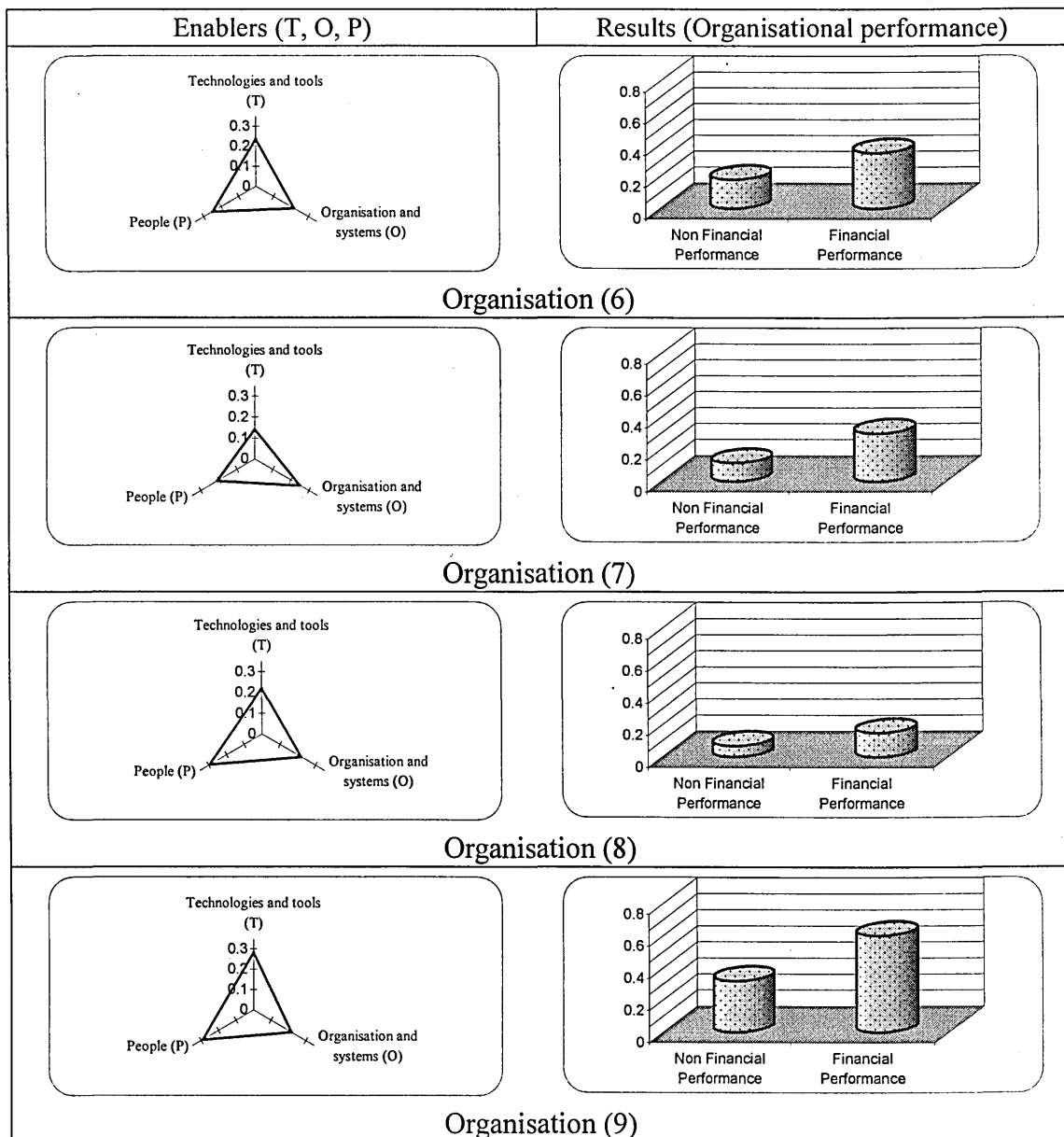

Figure 5.11: (continued)

Figure 5.12 shows the average values of the individual enablers/elements for all the nine first wave organisations. It can be seen from Figure 5.12 that action learning (38.9%) and learning loops/process (31.9%) continuous improvement (35%) training and education (37.5%), organisation potential behaviours (37.5%), organisation structure (37.5%), action learning (37.5%), learning loops/processes (32.5%) and empowerment (30.6%) are the key features for the first wave organisations. Enablers such as, empowerment, performance management, potential behaviours, shared vision/learning strategy, organisation structure, benchmarking, action learning and culture are also considered important in shaping and implementing TQM methods. It is also clear from

the Figure 5.12 that these organisations scored no value or relatively low values against the enablers considered essential for the second wave or third wave organisations. However, a surprising result in this sample was the lack of an appropriate information system within the first wave organisations.

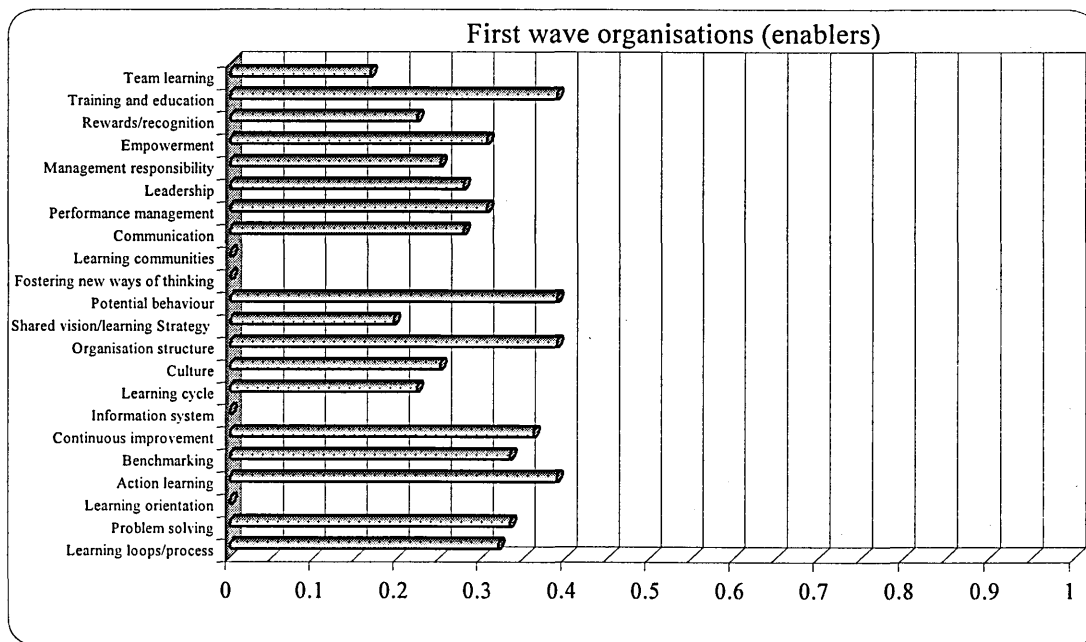

Figure 5.12: The average values of the enablers for the first wave organisations

Figure 5.13 shows the corresponding average values of the performance indicators ranked by the respondents of the nine first wave organisations. Again the average results show that the first wave organisations primarily focus on the financial measurements. Enablers such as, employee productivity (45%) and order cycle time (45%) scored relatively highest overall ratings in comparison to all other indicators. These followed by productivity (37.5%), workflow improvement (35%) and customer satisfaction (35%) indicators. Whereas, knowledge acquisition, storing processing and retrieving, information sharing process and individual competence development scored very low or no ratings at all. These are considered essential indications for the second wave and third wave organisations. In summary, the first wave organisations focuses on developing the employee skills to increase productivity (40%) in order to reduce the order cycle time (40%) as shown in Figure 5.13. Each organisation has adopted a different learning strategy at this level.

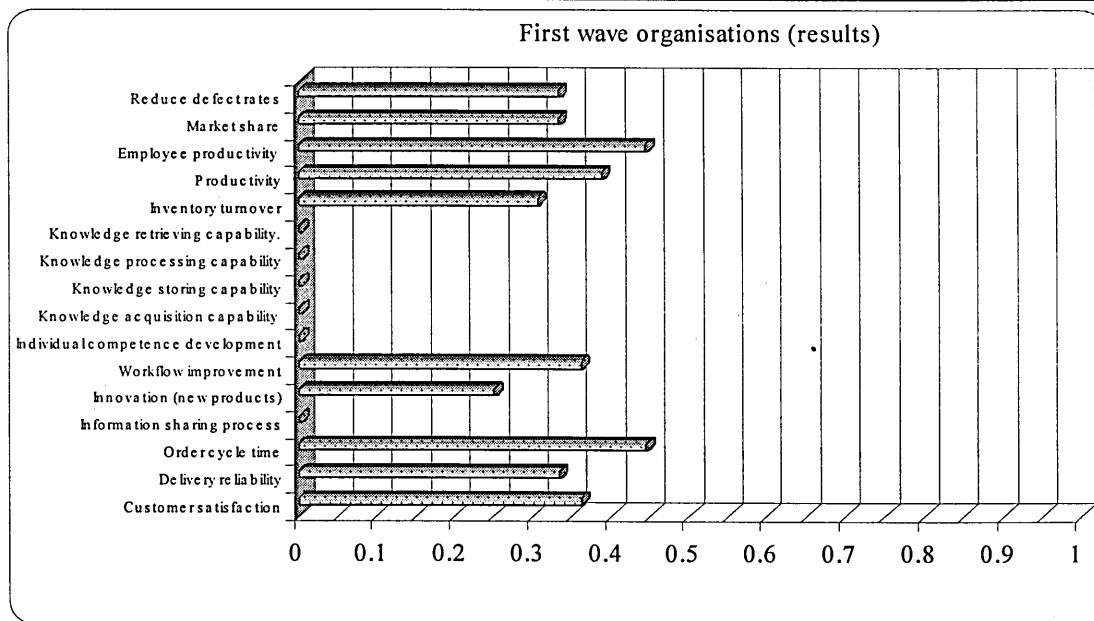

Figure 5.13: The average values of organisational performance for the first wave organisations

5.5.2 The second wave organisations

As illustrated in the framework the enablers associated to the second wave organisation include double-loop learning, information management, and challenge the existing knowledge to develop new norms, as shown in the framework (Chapter 4).

5.5.2.1 Case organisation B

The organisation B, has implemented TQM and information technology during the last three years. The organisation has less than one hundred employees and sales under £5 m/year.

As shown in Figure 5.14 the first wave enabler, for example, team learning (75%), training and education (75%), empowerment (75%), management responsibility (75%), learning cycle (75%) action learning (75%) and learning loops/ process, are the major outperforming elements. Also the second wave enablers such as fostering new ways of thinking (50%), information system (25%) and learning orientation (25%) have been introduced. Dynamic system wide performance was gained in order to fostering new ways of thinking and update and refresh the organisational memory.

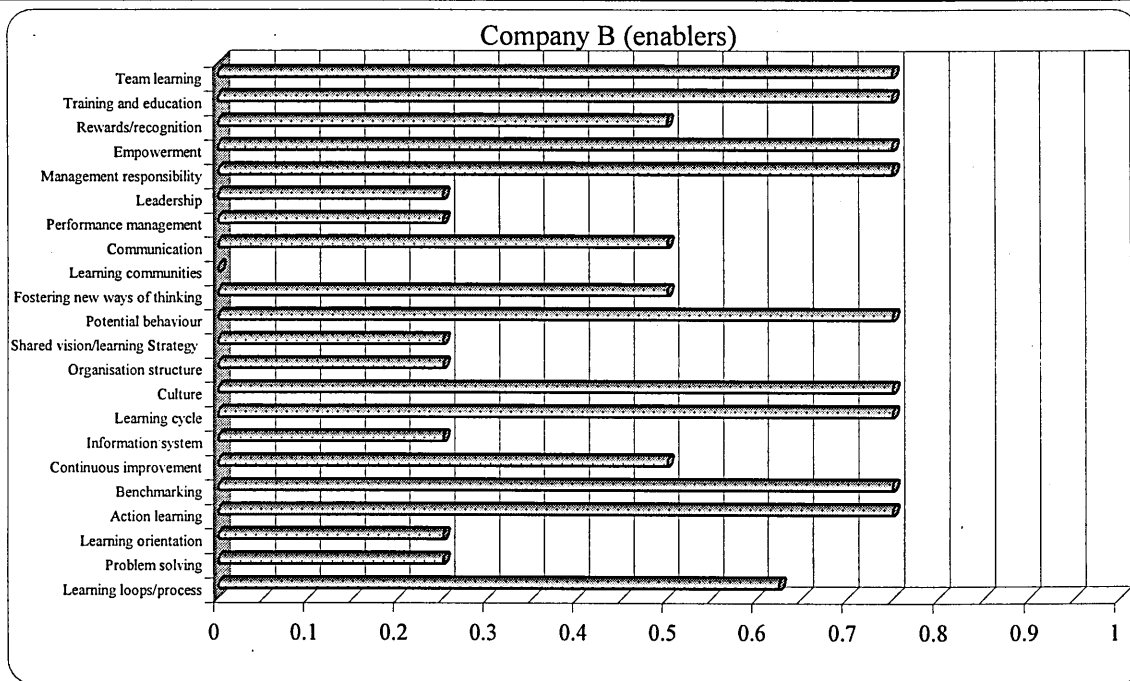

Figure 5.14: The values of enablers for the second wave case study

As with the first wave analysis, elements belonging to the technologies and tools, organisation and systems, and people category were summed and averaged. Organisation B scored 0.52, 0.438, and 0.625 respectively for T, O, and P as shown in Figure 5.15. Since the values of T, O, and P are between 0.33 and 0.66, therefore according to the set criteria organisation B fall into the second wave organisation.

Organisation B reported that the output of the learning activities would provide benefits by improving employee productivity (75%); increasing customer satisfaction (75%); improved information sharing process (75%); knowledge acquisition and storing capability (75%), improved workflow (75%), and improved delivery reliability (75%) as shown in Figure 5.16. But there have been parallel gains achieved financially, such as decreased defect rates (50%), productivity improvement (50%), inventory turnover (50%), innovation up by (50%), and order cycle time reduction by (50%). However individual competence development, knowledge retrieving and processing capability scored no ratings.

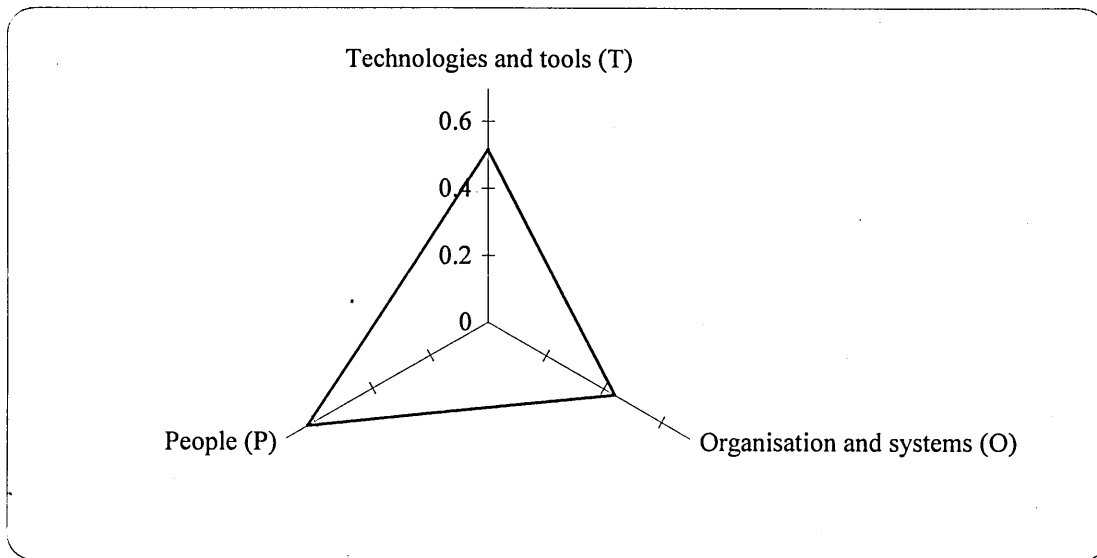

Figure 5.15: The average values of T, O, and P (enablers) for the second wave case study

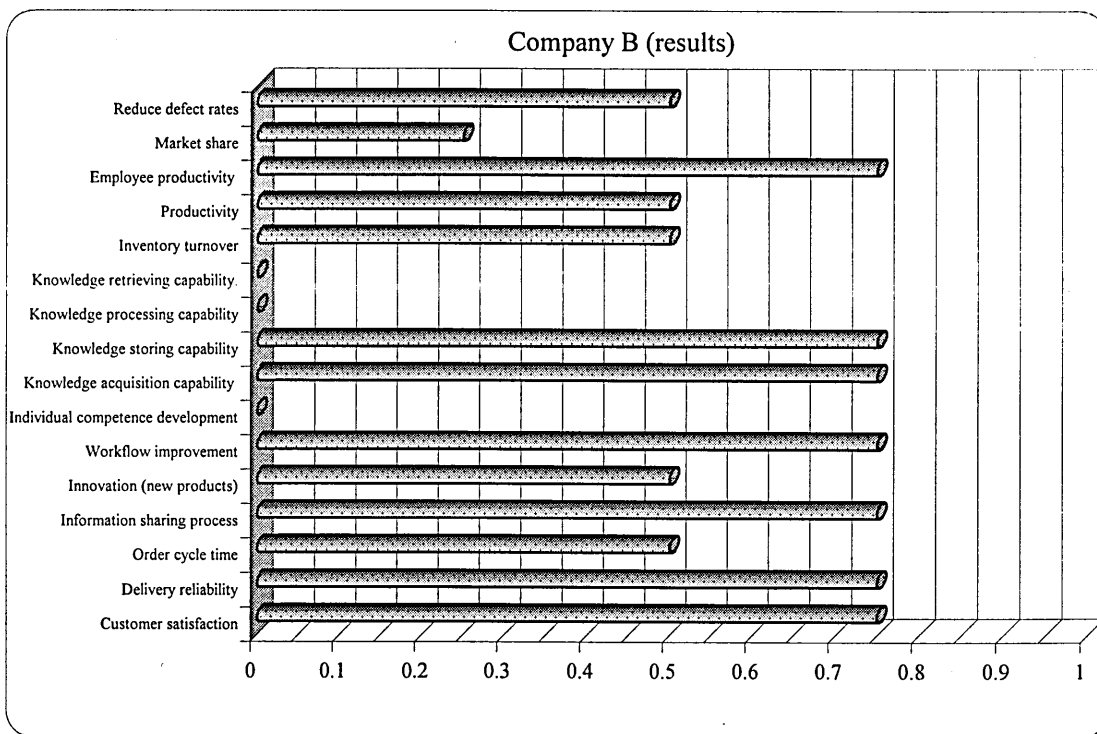

Figure 5.16: The values of organisational performance (results) for the second wave case study

Organisation B, reported that the financial and non-financial performance have improved by an equal values as shown in Figure 5.17. This suggests that the implementation of the double-loop learning elements and processes have enhanced the

Chapter 5
Implementing an organisational learning framework through questionnaire survey

non-financial performance results such as, knowledge acquisition and storing capability, and information sharing process. On the other hand the financial performance elements for example; employee productivity, workflow improvement, delivery reliability and customer satisfaction have been improved as well.

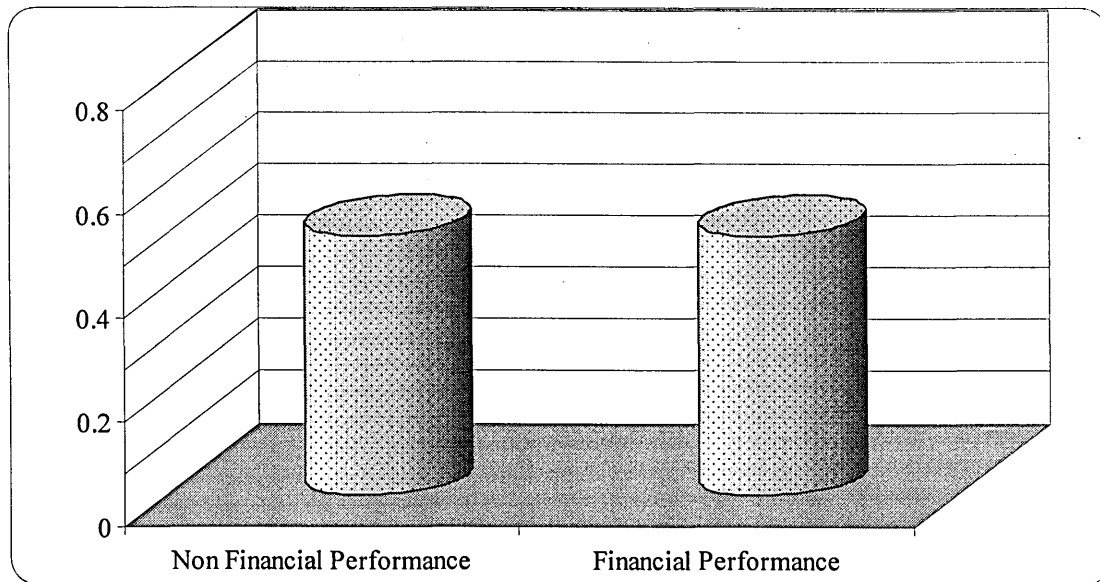

Figure 5.17: The average values of financial and non-financial performance for the second wave case study

5.5.2.2 Survey results for second wave organisations

Figure 5.18 illustrates the average score for the T, O, and P enablers and the corresponding financial and non-financial pattern for the individual second wave organisations. The analysis suggests that a total of thirteen organisations (50% of the sample) met the criteria of the second wave of quality by scoring between 0.33 and 0.66 average scores corresponding to the T, O, and P categorises respectively.

As with the first wave organisations it was difficult to deduce any correlation for the respective T, O, and P enablers and the corresponding result. However, substantial improvements were recorded in the non-financial performance category comparing with the first wave organisations. Actually nine out of the thirteen second wave organisations have scored equal or higher weightings for the non-financial performance comparing with the respective financial performance.

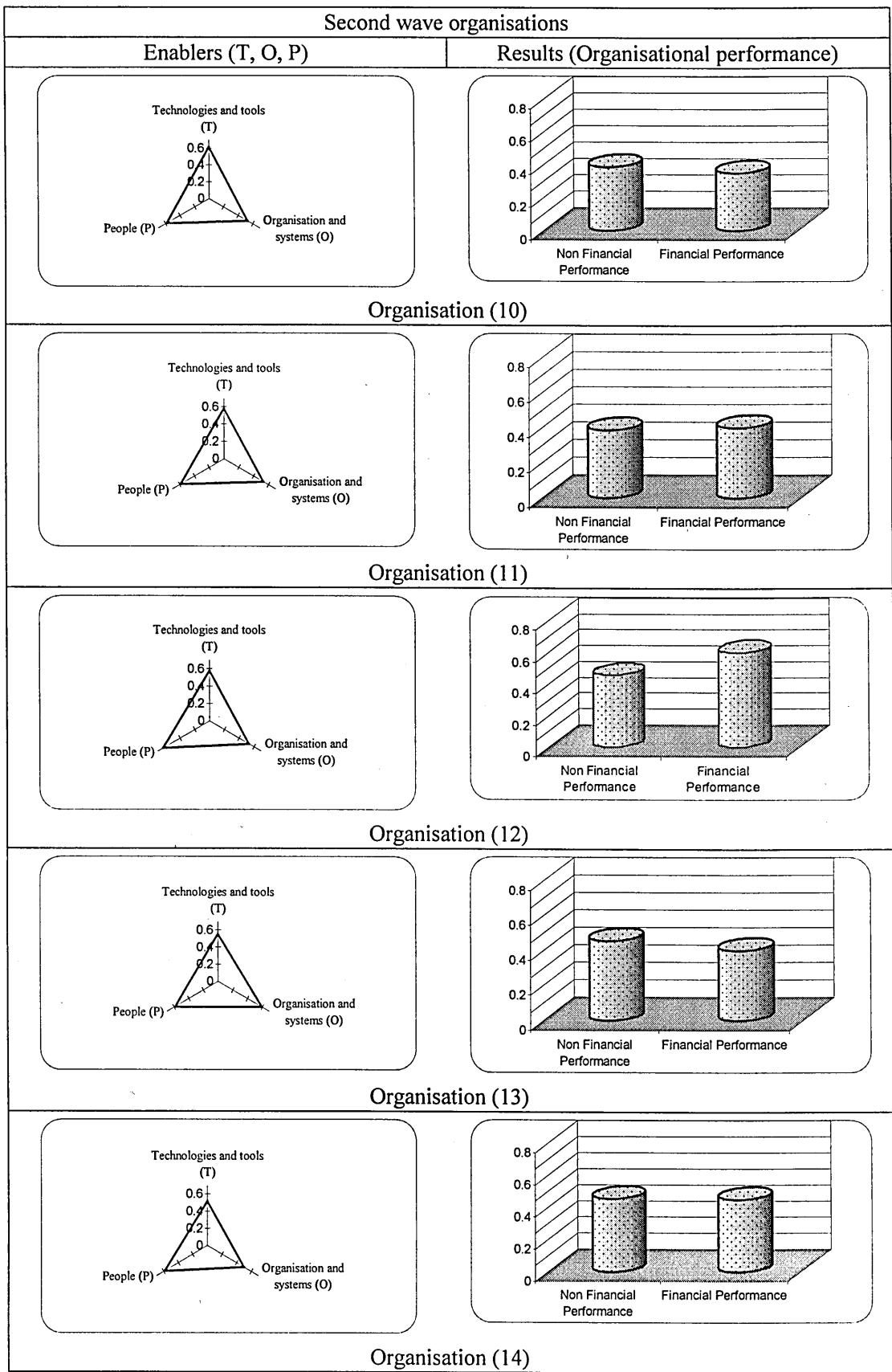

Figure 5.18: The average values of T, O, and P (enablers) and organisational performance (results) for the second wave organisations

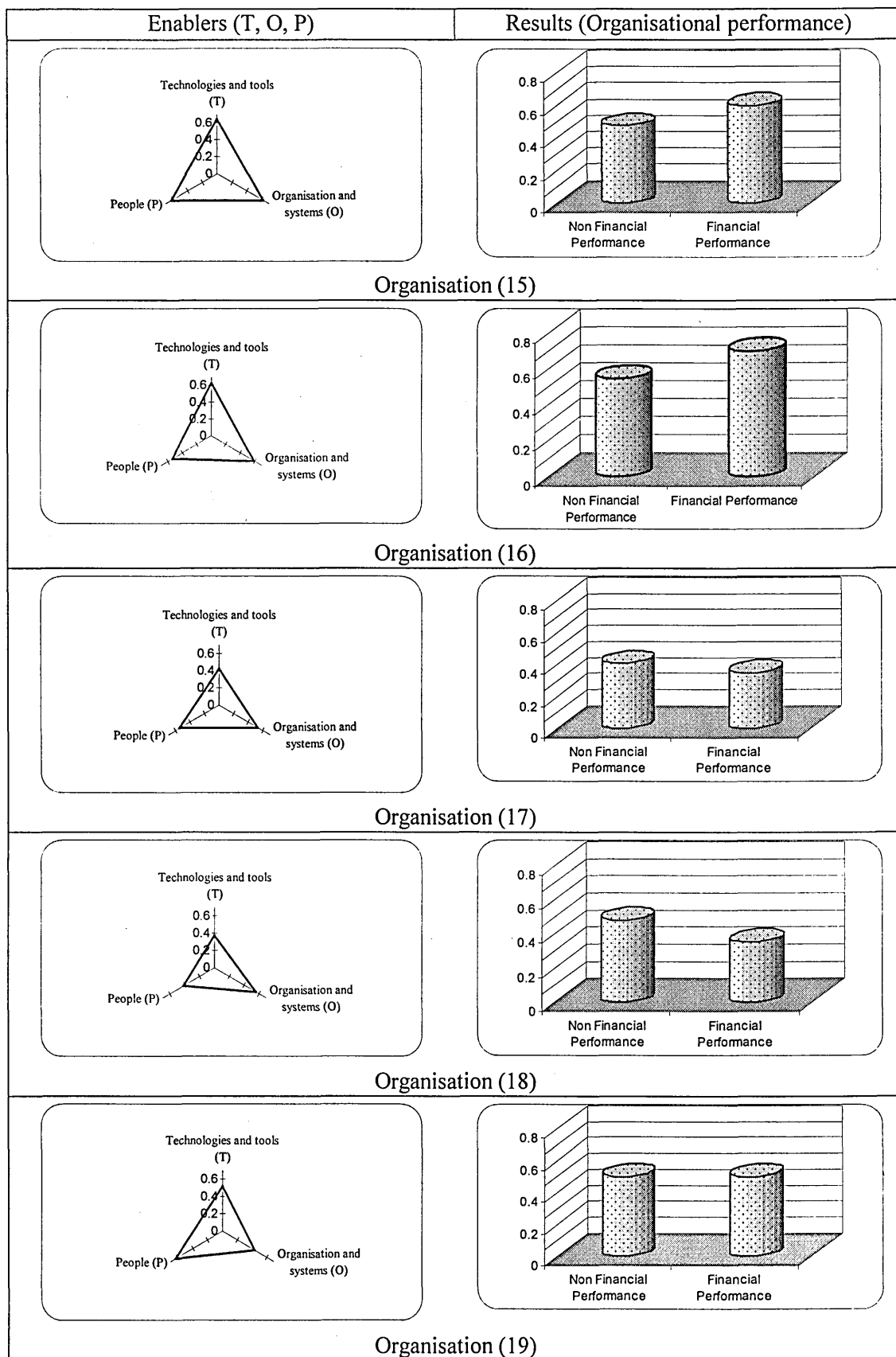

Figure 5.18: (Continued)

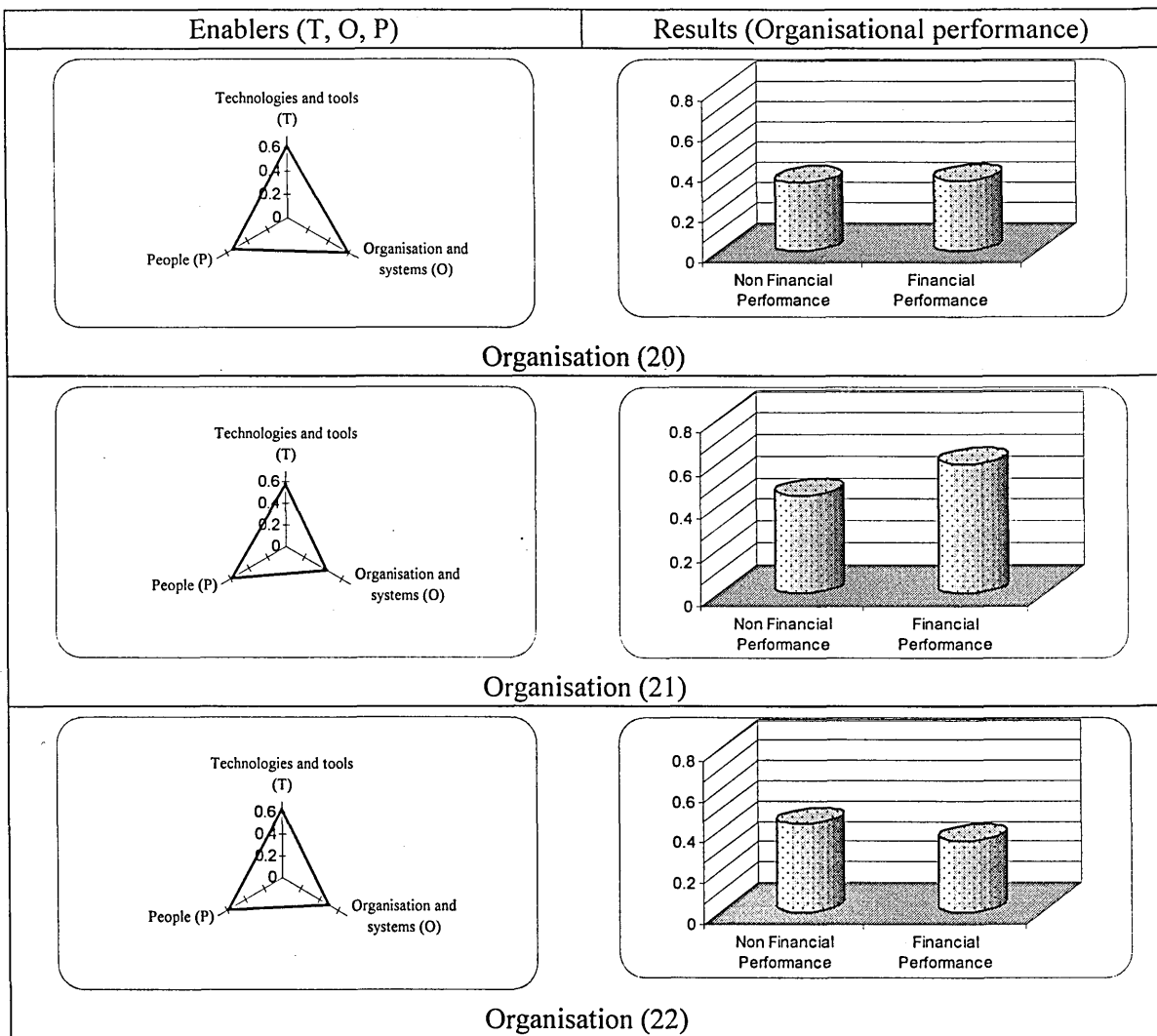

Figure 5.18: (Continued)

The second wave approach encourages organisation/groups to try to understand root causes and challenges them during the implementation processes by capitalising on the double-loop learning that has occurred. Management need to commit to and support a process that enables learning and substantial organisation and cultural changes.

Figure 5.19 shows the average values of the individual enablers/elements for all the thirteen second wave organisations. Collectively these organisations have cited changing organisation potential behaviour (score \cong 75%) as the most important enabler, followed by training and education (score \cong 70%), management responsibility (score \cong 65%), benchmarking (score \cong 62.5%), continuous improvement (score \cong 61%), team learning (score \cong 60%), fostering new ways of thinking (score \cong 60%) and learning loop/process (score \cong 57.5%). Comparing to the first wave, second wave organisations recognise the importance of an appropriate information system in place (score \cong 50%).

Also they are aware of the needs of a proper communication mechanism (score \cong 55%) within the organisation settings. Beneath such mechanisms underlay a qualitative auditing system that helps the process of dynamic learning.

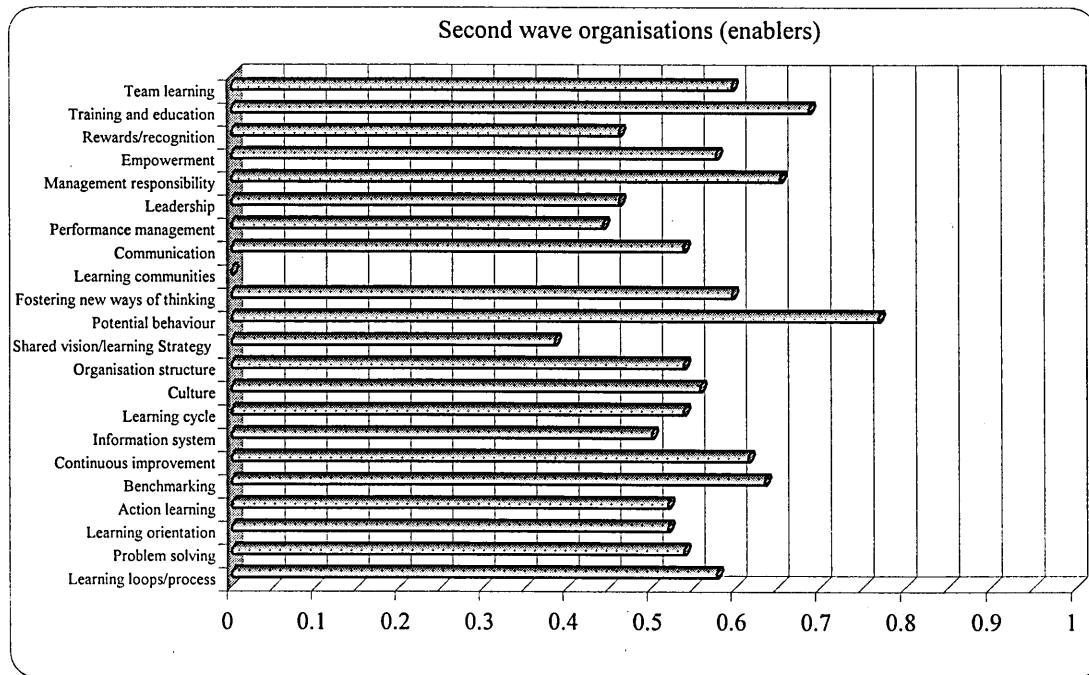

Figure 5.19: The average values of enablers for the second wave organisations

Figure 5.20 shows the average values for the output performance (results) for the thirteen second wave organisations. As compared with the first wave, second wave organisations have made significant advancements in the area of knowledge storing capability (62.5%), knowledge acquisition capability (57.5%), information sharing process (60%), workflow (55%) and employee productivity (52.5%). There are parallel gains achieved financially, such as an increase in market share as (25%) and customer satisfaction (55%). There is some correlation between learning an appropriate information system (enabler) with the increased information sharing process (60%). Knowledge acquisition (57.5%), storing (62.5%) and sharing capability (62.5%) indicators were rated relatively higher than the other indicators as shown in Figure 5.20. This vindicates the relevance of these indicators to the second wave of quality in the framework developed in Chapter 4. This also confirms the present author views that one of the emphases of the second wave of quality is about improving the business processes via information management.

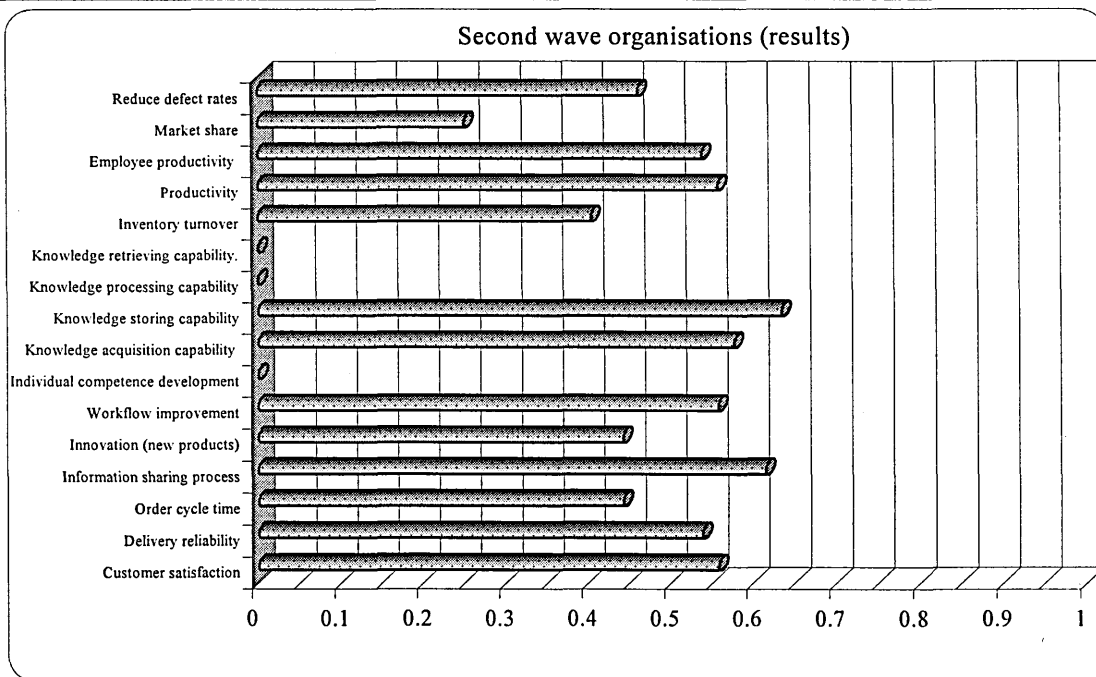

Figure 5.20: The average values of organisational performance for the second wave organisations

5.5.3 Third wave organisations

The third wave of quality was explored by the questions related to knowledge management and whether the organisation is developing individuals/teams competence.

5.5.3.1 Case organisation C

Organisation C has implemented the organisational learning programme five years ago. The organisation has less than 200 employees. The estimated sale for the last financial year was less than £50 m.

In most organisations the organisational learning activities were seen as the responsibility of several functions, usually working independently of each other. On the other hand organisation C challenged the premise that increase individual/team demands for learning, which in turn increased pressure to maintain or exceed an organisation commitment to learning. Figure 5.21 illustrate that the learning communities (75%) has scored high value at this wave of quality.

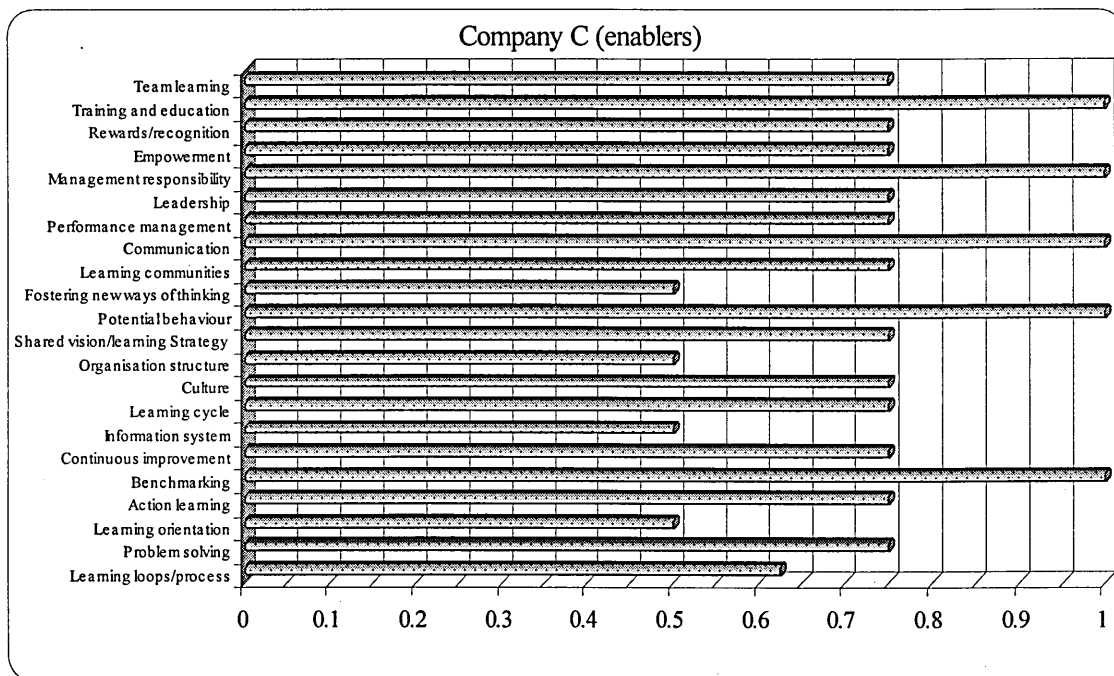

Figure 5.21: The values of enablers for the third wave case study

Figure 5.21 illustrates the pattern of achievement for establishing learning communities (75%) and the change in organisation potential behaviours (100%). Similarly training and education, management responsibility and communication all have scored full ratings (100%). The results obtained through the analysis show that skills development as a result of training and education challenge the organisation existing knowledge and foster new ways of thinking to develop new norms.

According to the criteria discussed above, the data was summed and averaged under the technologies and tools, organisation and systems, and people category. Organisation C scored 0.72, 0.75, and 0.83 respectively for the T, O, and P elements as shown in Figure 5.22. These values of T, O, and P respectively are higher than 0.66, which according to the framework developed in Chapter 4 is the bottom line for an organisation to be considered as the third wave organisation.

Figure 5.23 illustrate the financial and non-financial performance scores for organisation C. As shown in Figure 5.23 organisation C realised gains in employee productivity (75%), reduced order cycle times (100%), and customer satisfaction (50%). Also, organisation C reported an increase in information sharing process by (50%), improved knowledge acquisition by (100%), knowledge storing (50%), knowledge

Chapter 5
Implementing an organisational learning framework through questionnaire survey

processing (75%) and retrieving capabilities by (50%). Organisation C also reports an increase in individual/team competence by (75%). The measures were summed and average as represented in Figure 5.24 as financial and non-financial performance categories. Note that the non-financial values are relatively higher than the financial gains.

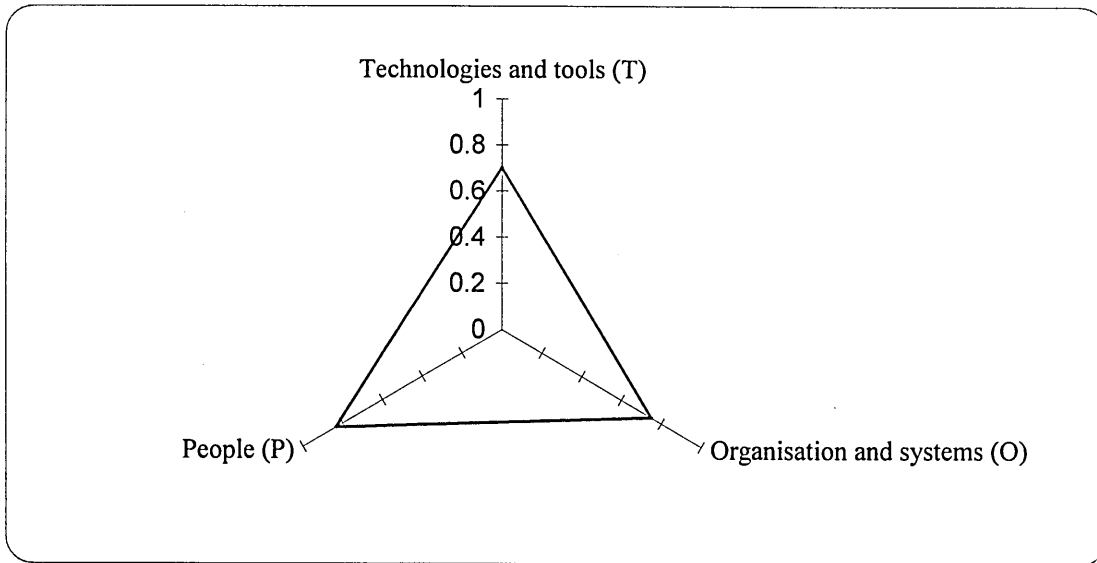

Figure 5.22: The average values of T, O, and P (enablers) for the third wave case study

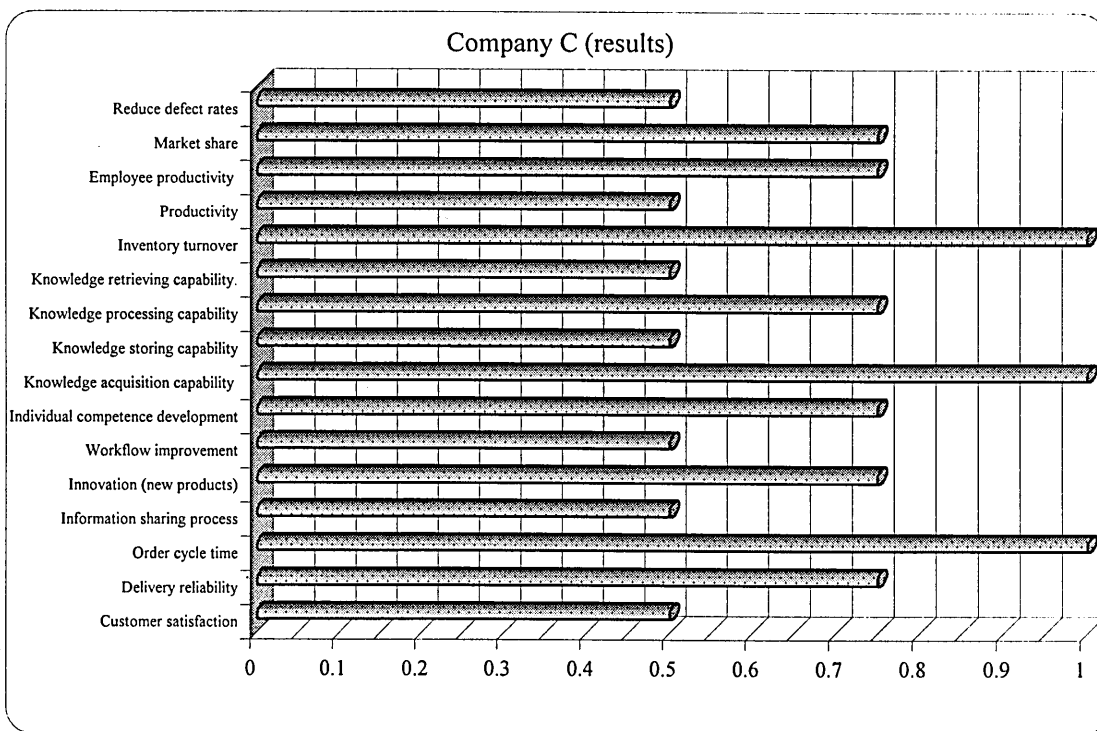

Figure 5.23: The values of organisational performance (results) for the third wave case study

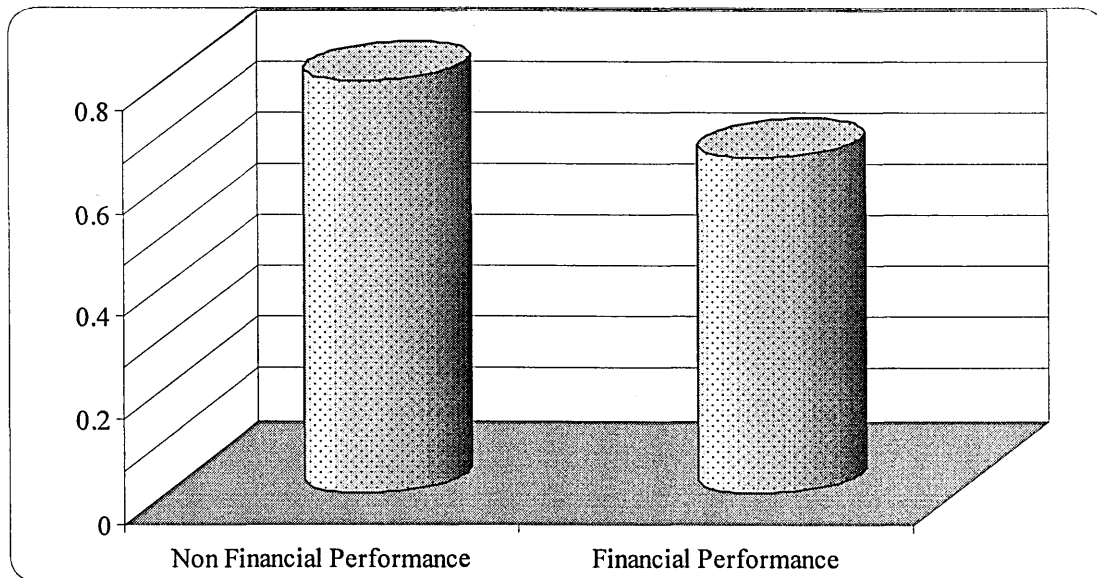

Figure 5.24: The average values of financial and non-financial performance for the third wave case study

5.5.3.2 Survey results for third wave organisations

Through the overall survey analysis, four organisations qualified as the third wave organisation (15% of the sample). As Figure 5.25 illustrates the average scores for T, O, and P elements and the corresponding performance measure for the identified organisations. As shown T, O, and P have respectively scored values higher than 0.66, as well as financial and non-financial performance values are relatively higher than the scores of corresponding first wave and second wave organisations. Also, three out of four cases, averaged non-financial performance has scored higher values compared with the respective weightings of financial measure.

Figure 5.26 shows the score of the individual change values of the enablers for the third wave organisations. The respondents have reported that the improvement in the organisational potential behaviour (scores 100%) as the most important factor, followed by training and education with (87.5%), building learning communities (87.5%) and benchmarking (87.5%). Whereas, team learning, rewards and recognition and communication scored a close second position with a score of 80%. Also establish learning communities (87.5%) and learning strategy (75%) were seen as the effective elements in creating a learning organisation. The organisation structure element on average scored low values (\cong 55%).

In terms of results (Figure 5.27) the third wave organisations have shown a significant emphasis with respect to the knowledge acquisition (80%), innovation and information sharing (80%). This supports the view, how information and knowledge are being disseminated is a critical area for organisational learning. The performance indicators include knowledge retrieving capability, increase in inventory turnover and productivity and reduced defect rates.

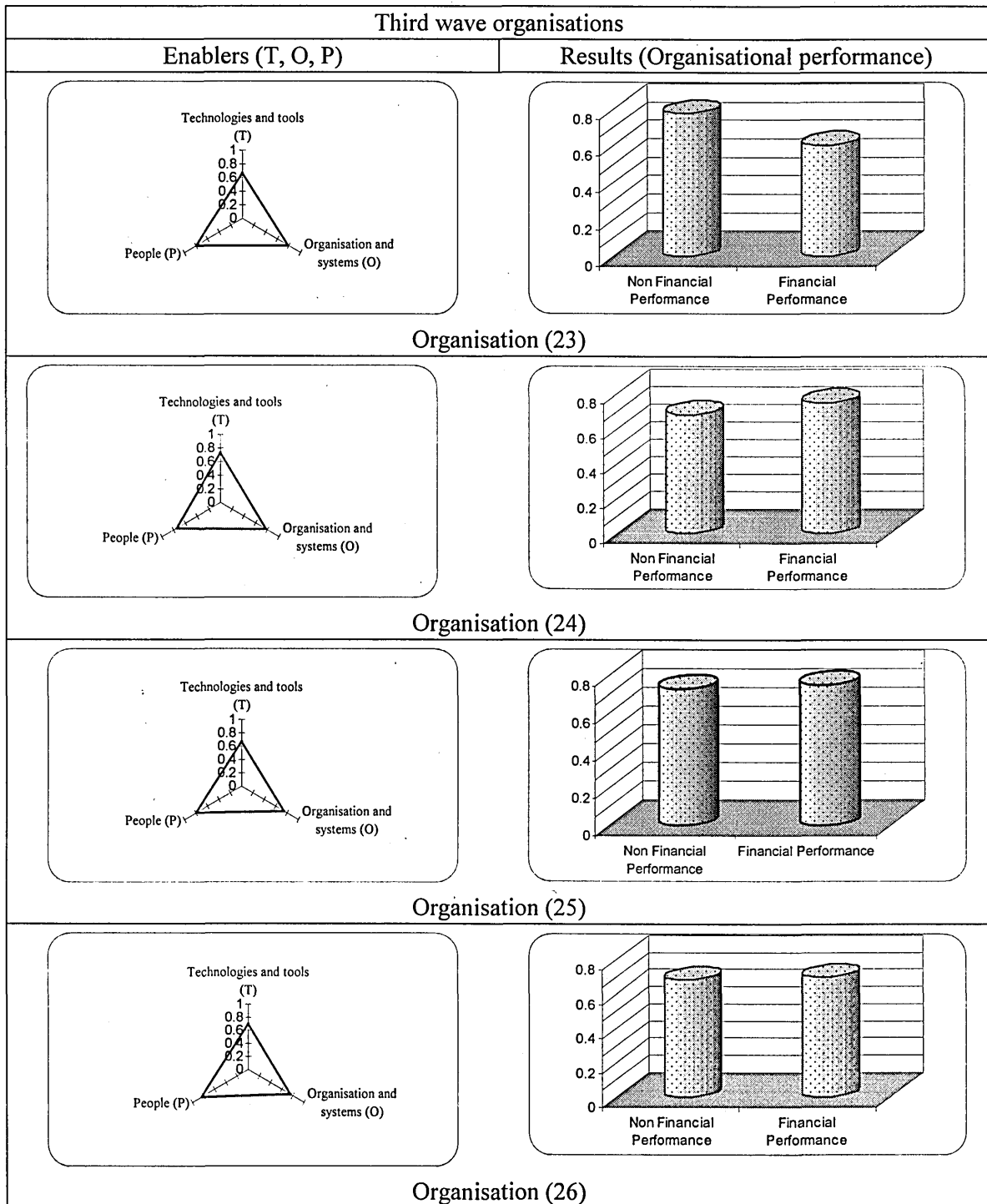

Figure 5.25: The values of T, O, and P (enablers) and organisational performance (results) for the third wave organisations

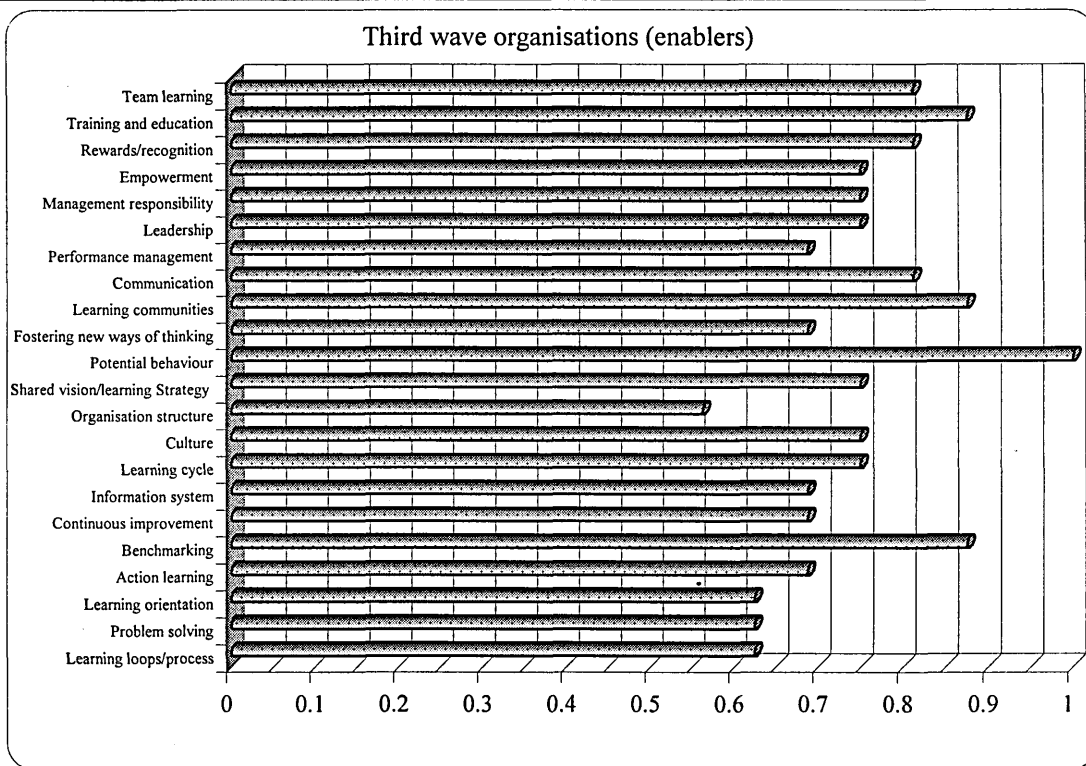

Figure 5.26: The average values of enablers for the third wave organisations

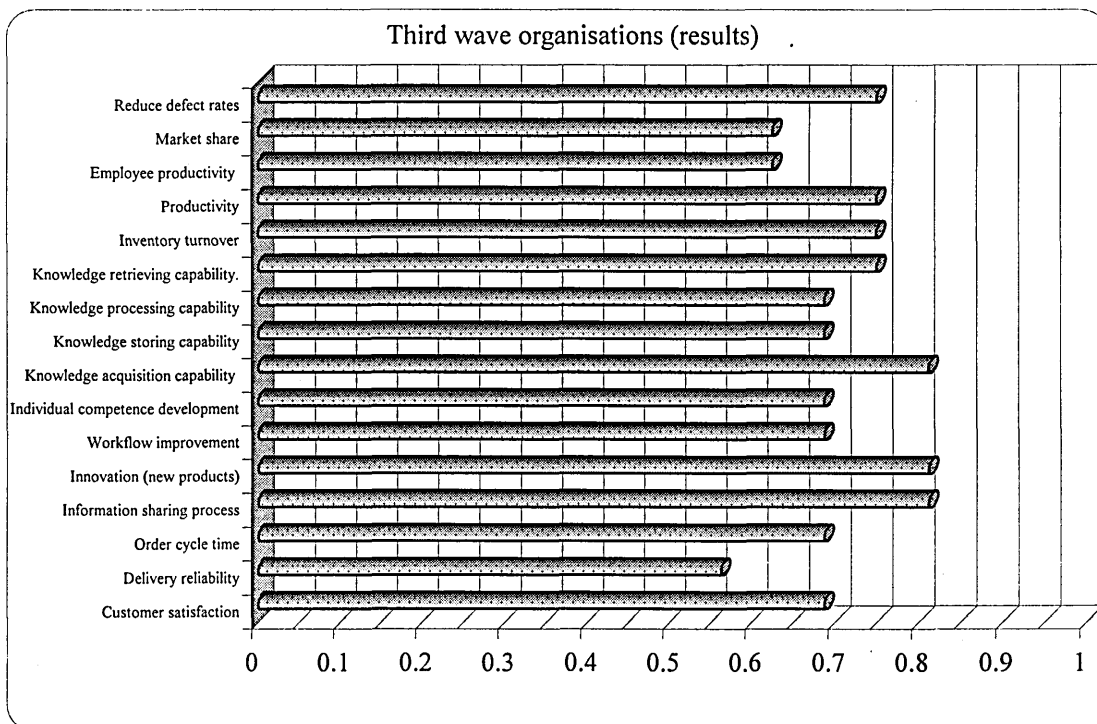

Figure 5.27: The average values of organisational performance for the third wave organisations

In comparison with the second wave organisations elements such as competence development (68%), knowledge retrieving (69%) and knowledge process capability (66%) have scored significant high values. These elements were almost non-existent in the second wave organisations. Only the delivery reliability scored (55%), which is comparable to the second wave organisations (52%). One explanation that delivery reliability is viewed as an external parameter depending upon the supplier performance, and not in the context of a supply chain.

5.6 Overall results and discussion

5.6.1 Enablers

The survey results indicated that about 65% of the respondents reported that individual/team learning is essential factors for organisational learning strategies and programs. This finding was valid across all the industries/sectors. Other soft issues, which were seen as essential organisational learning elements included: -

- Empowerment, management responsibility and leadership (75%)
- Team learning and rewards and recognition (81%)
- Performance management (68.5%)
- Training and education (87.5%)
- Culture and learning cycle (75%)
- Benchmarking (85%)
- Problem solving (62.5%)
- Communication (80%)

Beyond soft issues, information technology (67.5%) is cited by 43% of the respondents as a tool of organisational learning. The importance of learning processes was recognised by all to organisations surveyed. Most of the organisation focused on empowerment team learning and rewards/recognition. Figures 5.7, 5.14 and 5.21 show empowerment as one of the important element through the three quality waves. All organisations agreed that their learning initiatives have the highest impact on employee involvement and training. As shown in Figure 5.21 organisation C scored 75% for establishing learning communities. It indicates that the major learning initiative is to break down the barriers for employees in order to participate and commit more fully to the learning communities. However, responses for organisation A suggest that

Chapter 5
Implementing an organisational learning framework through questionnaire survey

inadequate training and the absence of learning loops/process are the reason why higher employee productivity is not achieved. This shows that employees need to be better trained to understand what quality means and how learning impacts in the organisation. However organisation B, score value of 25% more as the training aspect as a result of implementing learning process.

The three organisations A, B and C agreed that employee involvement does increase motivation levels, which in turns impacts on productivity. Organisation A, reported customer satisfaction increased by 30%; for organisation B defects reduced by 25%. Organisation C reports that defects rate gone down to 50%. Organisation C indicated that the knowledge management improvement and development of individual/team competence were more likely to have an impact on building a learning organisation.

Enquiring further into the T, O, and P model the average values of the three waves were analysed. Figure 5.28 gives the average score for all the 26 sample organisations categorised under the first wave, second wave and third wave organisations. As shown in Figure 5.28 technologies and tools element has scored an average 0.25 for the first wave, about 0.55 for the second wave and 0.70 for the third wave. This suggests that the organisations in the second wave and the third wave respectively, have progressively introduced new tools and technologies. Figure 5.28 also shows the importance of organisation elements, which have grown up from one-quarter for the first wave to over three-quarter for the third wave. Similar improvement is also recorded in the people elements, where scores for the third wave recorded even higher against the values of the technology and organisation counterparts.

Figure 5.29 gives a summary of analysis by showing the correlation between the respective T, O, and P dimensions for the twenty-six sample organisations. Looking at the clusters of first wave, second wave and third wave organisations, it is evident that there are definite enabling mechanisms to move from the first wave to the third wave continuum. Also there seems to be relatively stronger relationship for people versus organisation (systems) dimensions of the framework comparing with people versus technology or organisation versus technology dimensions.

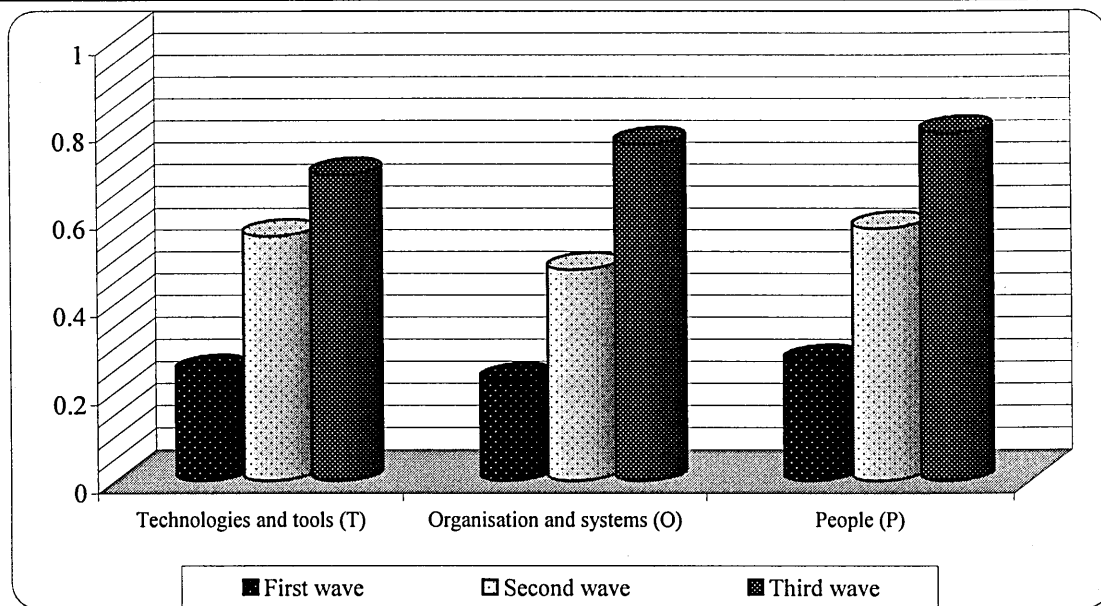

Figure 5.28: Average score of the twenty-six sample organisations according to T, O, and P classifications

The respondents cited people (38%) as the most important factor, followed by technologies and tools (36%) and organisations and systems (26%). Over two-thirds (67%) of the respondents thought that there should be more emphasis within their organisation on the people issues. This has vindicated the structure of the framework incorporating a greater degree of soft issues. Some 55% indicated there should be a greater emphasis on technologies and tools. While only 36% of the survey group believed that organisations and systems should play a greater role.

Survey results indicate that organisations are experiencing great difficulty in translating organisational learning theory into practice. Few organisations have effectively adopted a holistic approach to organisational learning. In fact, essential ‘building blocks’ for speeding the learning process in the organisation, such as, embedding new knowledge into the organisation and measuring the strategic value of competence assets, are almost completely absent or ineffectively performed in most of the surveyed organisations.

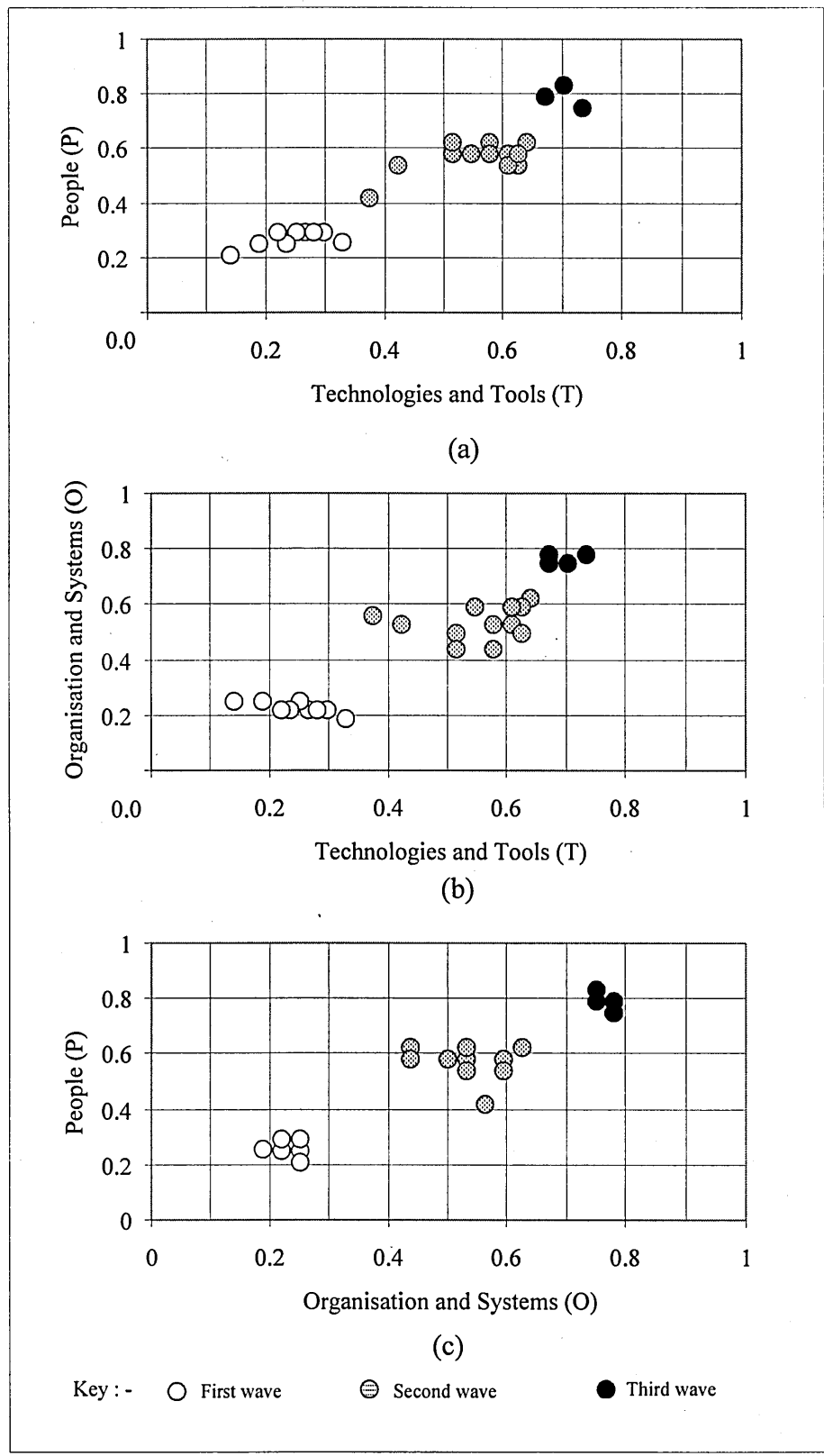

Figure 5.29: Correlation between the T, O, and P enablers for the twenty-six sample organisations (note: - some samples have identical values)

5.6.2 Learning organisation performance

The conceptual framework comprises a range of indicators and groups these according to financial and non-financial performance measures. More than half of the respondents have expected that organisational benefits in terms of reduced defect rates (37%), increased customer satisfaction (47%), improved information sharing process (81%), individual competence development (68%), increased productivity (46%) and reduced order cycle time (51%). Only a few respondents did not anticipate any improvement in organisation performance, and two respondents thought that improved learning process would not help to speed up the innovation process for new products/services.

Again individual organisation responses were summed and averaged under financial and non-financial categories. These were again summed and averaged to determine the overall performance for the twenty-six sample organisations. Figure 5.30, presents the collective scores of the indicators as grouped under non-financial and financial performance. For the first wave non-financial measures have scored very low (15%) against the financial counterpart (30%). On the other hand, non-financial and financial performances respectively for the second wave have comparable measurements (35% against 40%). With regard to the third wave, the non-financial performance scored slightly higher (68%) than the financial performance (65%), which shows the relative importance of non-financial measures in the framework.

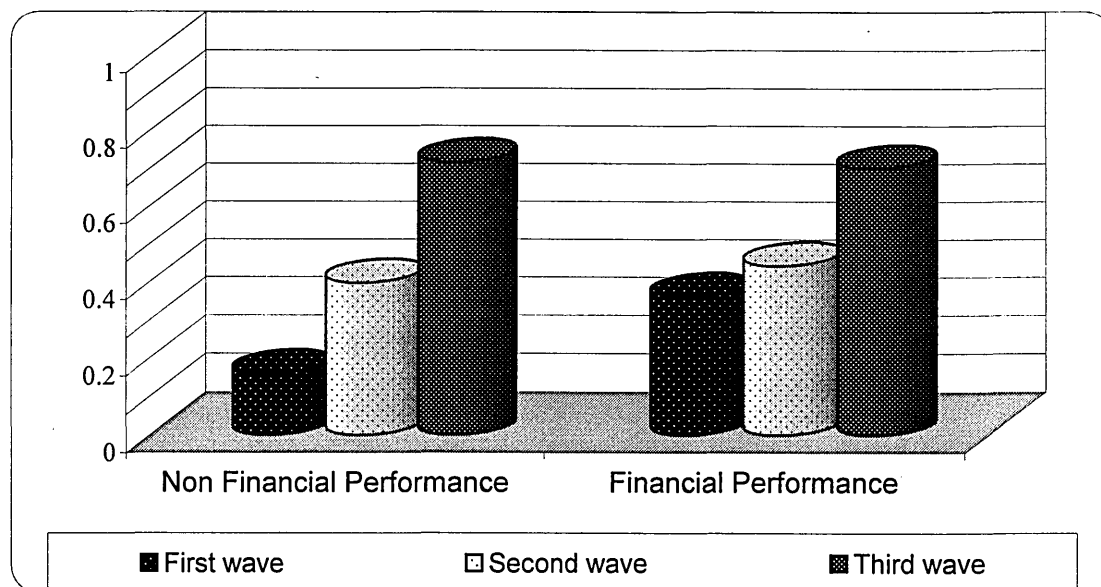

Figure 5.30: The overall financial and non-financial performance scores for the twenty-six sample organisations

Figure 5.31 represents the organisational performance under financial and non-financial categories. It is evident that financial and non-financial performances have a strong positive correlation, which indirectly quantifies the importance of non-financial measures with the organisation performance. Many first wave organisations didn't feel that they have made a significant improvement in the non-financial performance category. The main reason being that improvement in the innovation, workflow and skill development was not realised. Perhaps they didn't have any performance measure in place to this effect. Also such organisations were mainly concerns with the routine operations/products.

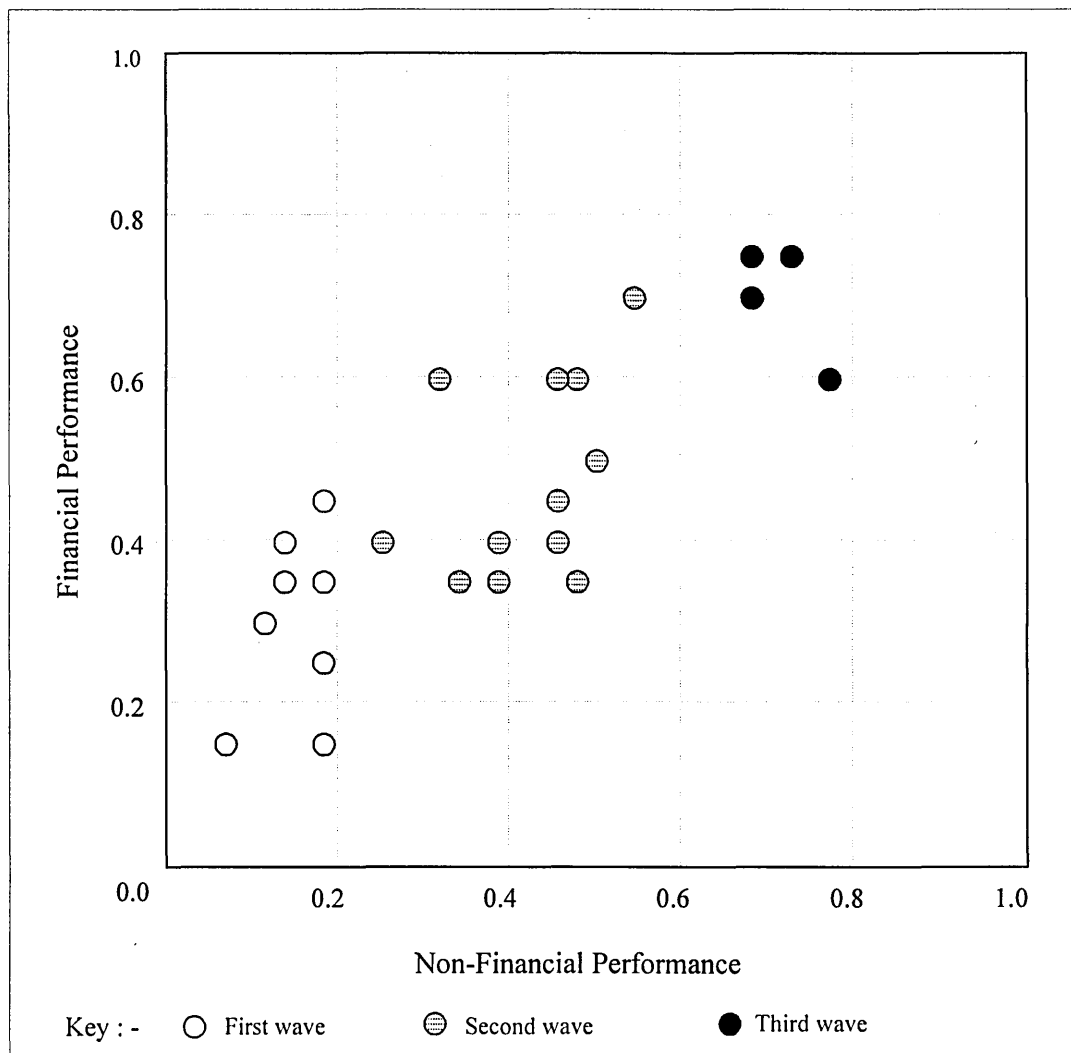

Figure 5.31: Performance matrix for the twenty-six sample organisations (note: - some samples have identical values)

Chapter 5
Implementing an organisational learning framework through questionnaire survey

In the financial performance category, very little difference was noted between the first wave and the second wave organisation (37% to 44%, respectively). So in essence, second wave is more about cultivating qualitative measures and essential organisation support systems in an organisation. However, with respect to the third wave, financial as well as non-financial performances improvement is recorded. The main difference between the second wave and the third wave organisations are the knowledge management efforts and the competence development programmes, and these organisations have experienced direct benefits of such implementation. These results are in line with the framework developed in Chapter 4 emphasising that non-financial measures are the key difference between the first, second, and third waves of quality. Finally, Table 5.3 summarised the overall profile of the twenty-six organisation respondents. Also presents the correlation between the respondent perception and the framework evaluation to validate the three waves of quality. Table 5.3 indicates that eighteen organisations (70%) of the respondents were found belongs to the role of framework analysis. Eight organisations (30%) were found not matched that role.

5.7 Summary

Whilst organisations recognise the importance of creating, processing and transferring knowledge, so far they have been unable to translate this competitive need into organisational strategies. This observation is supported by the fact that only two respondents reported that their organisations currently were 'very efficient' at leveraging learning to improve performance. In fact altogether, 65% respondents reported that their organisations were developing dynamic system wide performance as an organisational strategy. However, only 15% of the respondents indicated that their organisations were 'extremely good' or 'very good' at generating new knowledge, using knowledge in decision-making or accessing external knowledge (the third wave organisations).

To verify these findings, each respondent was asked (within the questionnaire) to indicate whether their organisation was developing an organisational learning strategy and/or if the organisation was either implementing or had developed specific continuous improvement programs. A total of nine respondents (35%) stated that their organisations were developing TQM as a base line for the organisational learning. Most of the seventeen organisations (65%) were in the early stages of rolling out programmes and initiatives to support their organisation learning strategies. Of these thirteen

organisations (50%) were in the second wave of quality implementing dynamic system wide performance. On the other hand only four organisations (15%), were actively introducing all of the organisational learning activities listed in the framework.

Organisation number	Sector			Implementation period			Number of employees (Size)				Estimated sale (£ m/year)				Organisation perception			Framework evaluation			Match	
	Manufacturing	Services	Public	≤3 Years	3 – 5 Years	5 – 10 Years	< 100	100 - 200	201 – 500	501 - 1000	> 1000	< 5	5 – 50	50 - 500	> 500	First wave	Second wave	Third wave	First wave	Second wave		Third wave
1	X			X						X	X					X			X			Yes
2	X			X			X						X			X			X			Yes
3	X				X					X				X			X			X		Yes
4	X			X						X				X		X				X		Yes
5	X				X			X				X				X			X			Yes
6	X				X			X					X			X			X			Yes
7	X			X				X					X			X			X			Yes
8	X				X		X				X				X		X			X		Yes
9	X				X			X					X			X			X			Yes
10	X				X				X				X				X			X		Yes
11	X				X					X				X			X			X		No
12				X			X						X				X			X		Yes
13		X		X								X					X			X		No
14		X		X			X					X					X			X		Yes
15		X			X					X				X		X				X		Yes
16		X			X		X							X		X				X		Yes
17		X		X				X					X				X			X		Yes
18		X		X			X					X					X			X		No
19		X		X			X					X					X			X		No
20		X		X						X			X				X			X		No
21		X			X			X						X			X			X		No
22		X		X				X					X				X			X		Yes
23			X	X			X						X				X			X		No
24			X	X			X						X				X			X		No
25			X		X			X					X			X				X		Yes
26			X	X			X						X		X					X		Yes

Table 5.3: The overall profile and results of the twenty-six sample organisations

Survey results indicate that organisations are experiencing great difficulty in translating organisational learning theory into practice. Few organisations have effectively adopted a holistic approach to organisational learning. In fact, essential ‘building blocks’ for speeding the learning process in the organisation, such as, embedding new knowledge

into the organisation and measuring the strategic value of competence assets, are almost completely absent or ineffectively performed in most of the surveyed organisations.

The organisations with strategies that correspond to the third wave strategies, reported that learning is taking place both at the organisational as well as at the individual level. However, for organisations still adapting first wave techniques, no or very little learning take place to improve production or training practices. The second wave creates an atmosphere where the individual learns by acquiring specialised skills.

In conclusion, from this sample group of organisations it is seen that although most of them understand the commercial or institutional demands to introduce organisational learning as a business strategy, few benchmarks of best practice have emerged. Indeed, when considering the noted lack of learning process expertise and skills and the cited organisational barriers to create knowledge-based organisations, the substantial difficulties organisations face in this critical transformation process becomes readily apparent.

In the next two Chapters, combining systems thinking, modelling technology and system dynamics to create appropriate learning environment for individuals as well as organisations would be discussed and may be one way forward. In order to identify learning barrier and to analyses how the information and knowledge is disseminated over time the dynamic model would be developed. It intends to ensure that information and knowledge are getting to the right place within the shortest duration. The dynamic model would speeds up the learning process within an organisation.

5.8 References

- Likert, R. A. (1952), A technique for the development of attitude scales, *Educational and Psychological Measurement*, 12, 313-15.
- Hague, Paull, (1993), "Questionnaire design", Kogan Page Limited
- Denscombe, Martyn, (1993), "An introduction to questionnaire design", Leicester Business School.
- Kompass Company Information, (1998), CBI-UK, Reed Business Information.

LEARNING PROCESSES MODELLING

6.1 Introduction

Learning for the purpose of this section is studied as a process to detect and correct the error and to challenge the existing knowledge in order to develop new norms. This concept can be applied at individual, teams and/or organisational levels and is anticipated to develop explicit link between learning and performance. Relationships between, training, skills and competence development and knowledge are explained, which the present author believes are the main ingredients in the learning process.

Elements of TQM and organisational learning identified respectively, in Tables 4.1 and 4.2 (Chapter 4) showed that many enablers are common (e.g. benchmarking, leadership, organisation structure, management responsibility, empowerment, rewards/recognition and training and education). Other enablers indicate that there is an implicit relationship between TQM and organisational learning. In this Chapter, TQM and learning organisation relationship is illustrated more explicitly in a causal-loop form using system dynamics. Also guidelines are provided how to understand the time-based dynamics of skills attribution and training programmes within an organisation setting.

6.2 System dynamics

System dynamics is defined as a modelling and simulation methodology to study the complex dynamics of large, non-linear managerial, socio-economic, human systems (Richardson, 1981). There are three main tools to represent a system dynamics model: Causal-loop or influence diagrams, stock flow diagrams and equations, in increasing order of detail and precision. An example of how to develop a system dynamics model is illustrated in Appendix 6.1.

Causal thinking is at the core of organising ideas. The core of a system is the composition of its structure, which contains circular chains of cause and effect relationships (causal feedback loops) to control its behaviour. Causal-loop diagrams display all the major influences and feedback loops that exist between variables; they provide a qualitative representation of the feedback structure of the system. A more

detailed and precise representation is the stock flow diagram. A stock flow diagram consists of stocks, flows and converters. Stocks reflect the condition and accumulations within the system at any point of time. Flows represent activities that change the stocks in the system. They are connected to stocks that they either fill or drain over time. Mathematically, flows represent the time rate of change of stocks.

Converters are intermediate conversion variables used to model the effect of several variables on a flow variable. A stock flow diagram is a more concrete and detailed model of the dynamics of the system than causal-loop diagrams. Finally, the most precise representation consists of equations that describe how all the variables are interrelated in the system. Mathematically, a system dynamics model corresponds to a set of non-linear simultaneous differential equations (Richardson, 1981). There are no analytical solutions for such models. Computer simulation is therefore used to analyse the behaviour of such complex dynamic models. Various software packages exist for system dynamics modelling and for the purpose of this study *ithink* software is used.

System dynamics as a modelling tool is used in this work due to its following advantages (Purnendu, 1998).

- System dynamics considers a holistic view of the problem. The modeller can integrate a number of subsystems to give an overall picture of the continuous improvement processes system (e.g. a step by step procedure for developing TQM model in this work).
- The modelling effort goes towards experimentation on policy issues (e.g. how many employers to retain).
- Dynamics of the process in a medium to long term. Since system dynamics is a methodology for analysing strategic issues, a long term horizon is desirable (around two years in this study).
- Feedback loops as the basic building blocks of a model. A feedback loop is created whenever an input to a system is affected by its output. For example, the organisation, when selling goods from built-up inventories, usually takes into account the current inventory level when planning future production. If inventory is too high, production will usually be slashed; if the inventory is too low, production

will go up. This creates a loop in which inventory affects production which affects inventory, which, in turn, influences production.

- Endogenous explanation of system behaviour. Modelling causal structures in feedback loop helps the endogenous explanation of real system behaviour (e.g. how staff training would improve productivity or quality).
- Structure rather than the parameter values for a system. A feedback structure can generate similar behaviour for a wide range of values of parameters. Thus, model structure is given priority over model parameters (a total system view).
- Validation through a multi-stage procedure. Building confidence in a system dynamics model and its usefulness are considered more important than the absolute model validity. Model validity in system dynamics is established through qualitative judgement and quantitative analysis (this is quite useful for modelling soft issues such as skills and training).
- Model understanding as the basis for designing new policy. System dynamics requires a complete understanding of the causal structures and mechanisms, which generate the behaviour of interest. This understanding paves the way for designing new policy structures (for example new recruitment or training policy).

Causal-loop diagramming has been applied in areas such as production, inventory management, manpower planning, research and development management, capacity planning, corporate planning and quality management (Purnendu *et al.*, 1998). An earlier project used system dynamics to model the interaction between competitive capabilities of quality and cost during total quality management (TQM) initiatives (Burgess, 1996). System dynamics has been around for a number of years (Forrester, 1961) and has received a boost recently with the prominence of systems thinking as promulgated by such as Senge (1990). System dynamics has often been seen as a hard-edged approach because of its quantitative aspects. Nowadays, its use as a “soft” tool in problem structuring is increasingly recognised. This is particularly the case with TQM where system dynamics is used to develop high-level models (Purnendu *et al.*, 1998 and Anil, 2000).

6.3 System approach for organisational learning

System dynamics is used in the current work to develop a family of conceptual learning models, which describes the relationships and influences between the three waves of quality. The models are used to highlight the main variables that have a dominant impact on the functioning/performance of the learning organisation. These models represent the major feedback loops that would stimulate or inhibits the learning process in an organisation.

Influence diagram (causal-loop) (Coyle, 1977; Mohaparta *et al.*, 1994) are constructed in order to link the major variables of the first-loop, double-loop and triple-loop, as identified in Chapter 4, through cause and effect relationships. The primary focus in system dynamics (and in causal-loop diagramming) is the examination of the effect of one element on another. The overall simplistic causal-loop diagram as identified in Figure 6.1 establish the cause-effect relationships among the major factors or variables of the first-loop, double-loop, and triple-loop learning.

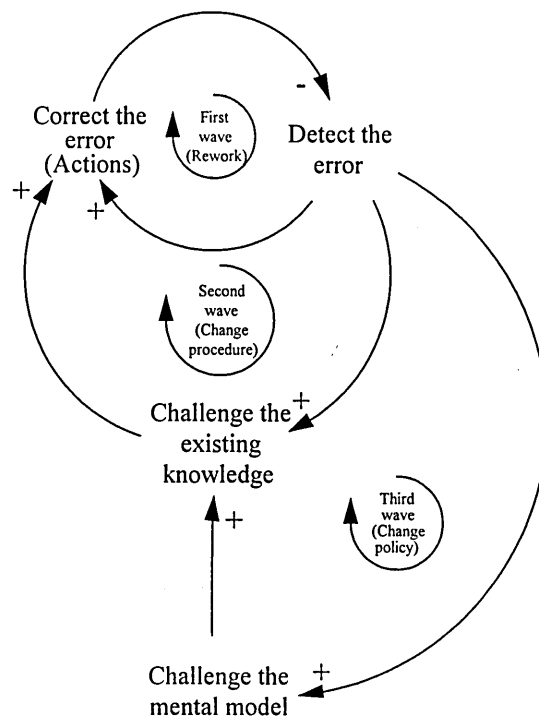

Figure 6.1: Influence diagram of the three quality waves.

The simplistic model is composed of those components of a quality waves concerning flow of information and allowing for a way of intervention. More specifically, the model is built to analyse the learning loops. As such, the model must represent the learning processes like, skill acquisition through training, the existing knowledge to

introduce new norms by learning, and how to develop the organisation competence pool. The definitions of the learning, knowledge, skill and competence are presented in Table 6.1.

Term	Definition	Author
Learning	The process of improving actions through better knowledge and understanding	Fiol and Lyles (1985)
Knowledge	Knowledge is the appropriate collection of information, such that it's intent is to be useful. Knowledge is a deterministic process.	Gene Bellinger (1997)
Skill	Skill is the ability to master the concepts of a discipline or domain, and to apply this knowledge appropriately in new situations.	Sanchez <i>et al</i> , (1996)
Competence	The set of skills and knowledge that an individual needs in order to effectively perform a specified job.	Baker <i>et al</i> . (1997)

Table 6.1: Definitions of learning, knowledge, skill and competence.

6.3.1 First wave influence diagram

Quality improvement is determined by defect correction less the rate of defect generated. Work processes sometimes fail to cover inputs into the desired outputs; items produced incorrectly are termed defects. Defect will be used as a generic term for any undesirable outcome of a conversion process (Schneiderman, 1988). For example a product produced correctly but delivered late is defective if timely delivery is a desired attribute of the conversion process. Figure 6.2 shows the basic physical relationship between training rate, the skill level, defect generated and quality improvement in the form of a causal-loop diagram (Forrester, 1961 and Richardson, 1991). In Figure 6.2, an increase/decrease in defect correction causes an increase/decrease in quality improvement. Also, an increase/decrease in quality improvement causes an increase/decrease in training rate. But skill level increases by increasing the training rate. Evidently increasing the skill level reduces the defect generated.

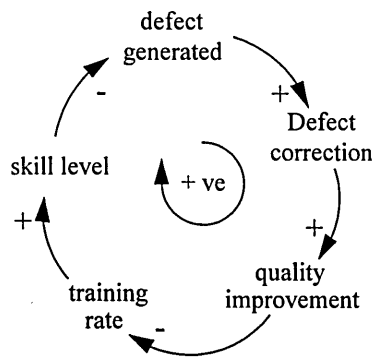

Figure 6.2: A causal-loop diagram of skill and quality improvement

A fundamental contribution of TQM's founders was to recognise the distinction between "correcting" defects and "preventing" them from occurring (Deming, 1986). The present author agrees with the view that the causes of defects may be attributable to the actual skill level. Skill is the ability to master the concepts of a discipline or domain, and to apply this knowledge appropriately in new situations (Sanchez *et al.*, 1996). The skill level in an organisation should have an effect on the defect rate. As shown in Figure 6.3 the actual skill pool is increased through skill acquisition. Similarly, skills acquired increase by increasing the rate of skill recruitment. The organisation needs to constantly check the skill level as skill gap may arise due to employ turnover (skill pool) or by changes in products and process that render existing skills and procedures obsolete (skill level).

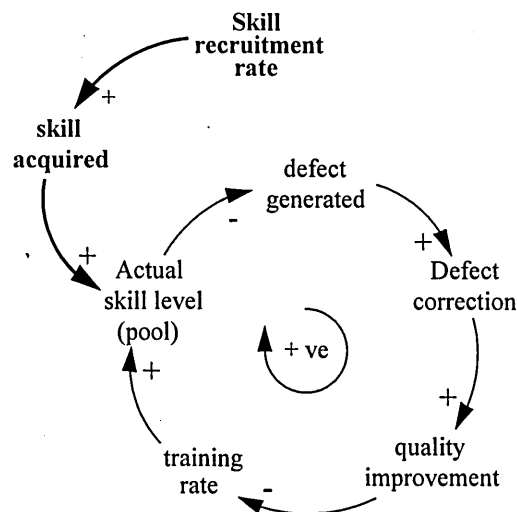

Figure 6.3: Causal-loop diagram of skill level

Consider the feedback loop by which managers regulate the skill level. Managers assess the adequacy of actual skill level by comparing it to desired skill level (Figure 6.4). Desired skill pool is determined by the demand for the organisation's products or services. The comparison of desired and actual skill level generates the skill gap.

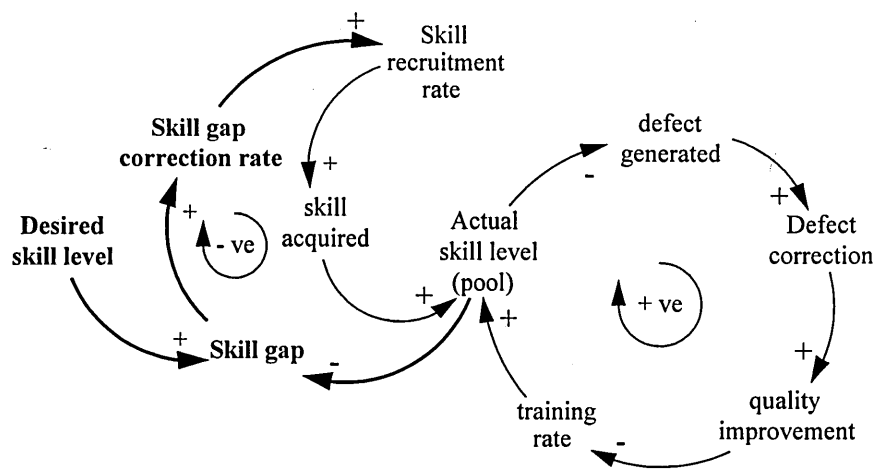

Figure 6.4: Causal-loop diagram of skill level with skill gap correction.

Figure 6.4 represents a negative or self-reinforcement feedback loop in which an increase in the skill gap correction rate attributed to adjust the skill gap. This would dictate the additional skill recruitment rate, which in turn would lead to increase the actual skill pool. The loop is created by adding a link between skill gap and recruit skill rate. Also this loop attempts to control the level of actual skill such that the gap between the organisations desired skill level and its current skill level is minimised. This model has the same structure as of standard IOBPCS (Coyle, 1977).

The causal-loop diagram shown in Figure 6.5 illustrate that, starting from the basic feedback configuration of skill level based on recruit skill control system, a more complicated model is obtained using feed-forward of the present skill loss rate to influence directly the skill recruitment rate. In section 6.5.1 present skill loss rate is exponentially averaged and feedback to the original recruit skill rate. The average skill loss rate is referred to as an inertial component of the system as shown in Figure 6.5.

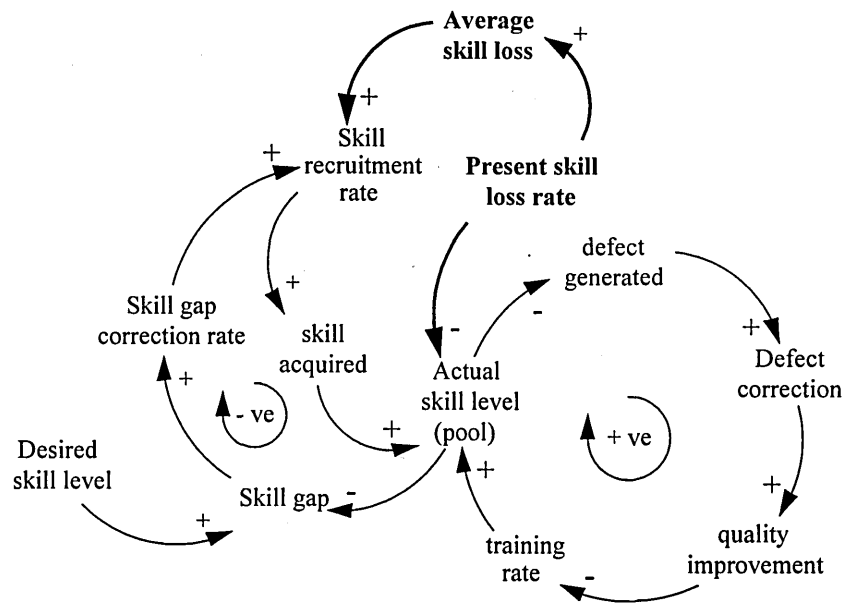

Figure 6.5: Causal-loop diagram for skill loss rate

When employees are asked to participate in the transformation to a quality organisation, extensive training is imperative. Samson and Terziovski (1993) believe training is vital to the internal diffusion of quality ideas and practices, as without it there is no solid foundation for formal quality programme. Training basically has two major benefits, it is a method for involving employees and it increases the skill level of employees.

Training is measured by the level of acquired skill. Figure 6.6 provides a broad picture of what the most important variables and feedback loops are. The additional variable and links creates another positive feedback loop. This balancing loop is related to the effect of training on the skill level. The loop consists of actual skill level → skill gap → skill gap correction rate → skill recruitment rate → training completion rate, which close the loop by affecting actual skill level. This loop captures the development of trainees. While the linkage that it is created it is strongly supported by the desired value of trainees, the main impact is the adjustment of the trainee development that should result in better overall business. Clearly the rate of trainee development increases the skill rate as shown in Figure 6.6.

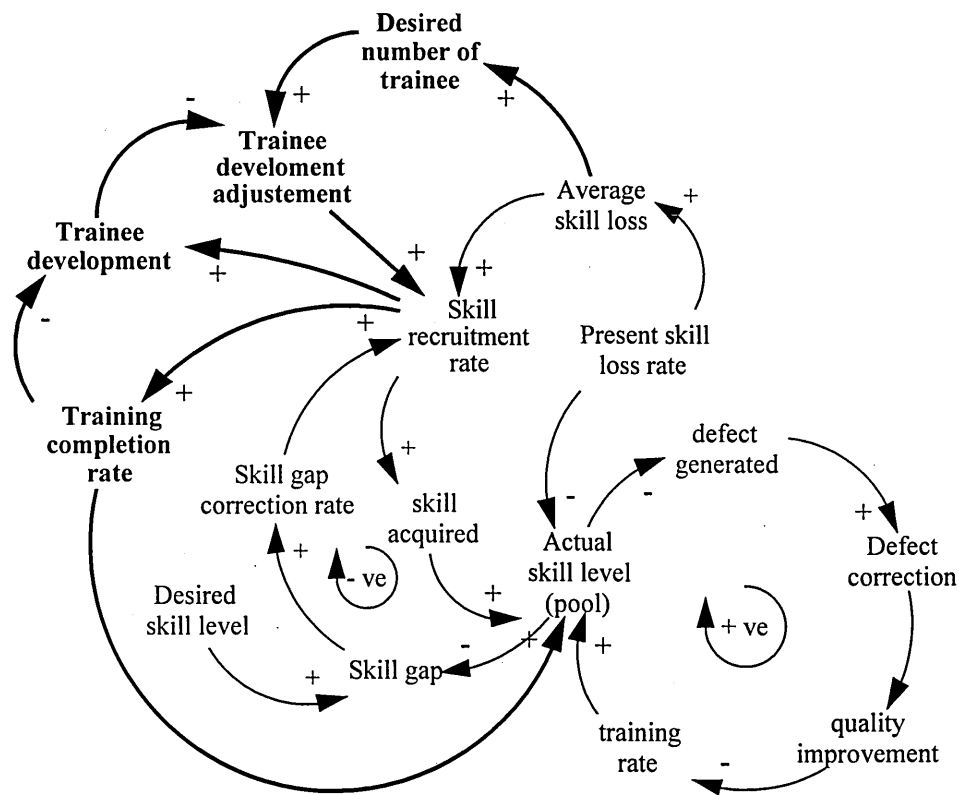

Figure 6.6: Causal-loop diagram representing first wave of quality

As shown in Figure 6.6, first wave describes a learning process as a learning to detect and correct the error from the existing norms and values. In an organisation context learning processes are usually measured by efficiency. The measure of objective fulfilment is attained with the help of effective adaptation of given objectives and norms without being at a tangent to the central organisational system of defaults and standards (Probst & Buchel, 1994). The optimisation of the existing system, by identification and elimination of errors, is the essential aim. Because existing norms and defaults are not reviewed, the total capacity to solve problems cannot be increased (Figure 6.6).

6.3.2 Second wave influence diagram

As explained in Chapter 4 double-loop learning has challenged the existing knowledge to introduce new norms and ideas. As shown in Figure 6.7 with the birth of new ideas as the results of the increase the acquiring the applicable knowledge to the organisation. Similarly, the feedback from the implementation of new ideas would affect the level of actual knowledge.

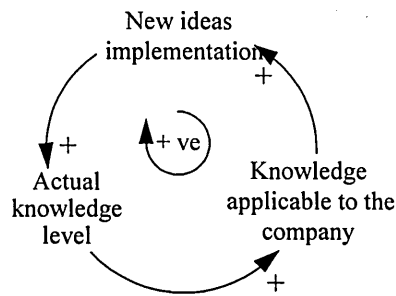

Figure 6.7: Causal-loop diagram illustrating the relationship between knowledge and new ideas

Also, with this research the actual knowledge level is a function of learning completion rate, which is affected by the knowledge acquisition rate. Also, the higher the knowledge acquisition rate means the higher the learning rate as shown in Figure 6.8. In reality the extent to which an organisation is involved in adjustment the knowledge gap has an impact on the growth of this actual knowledge level.

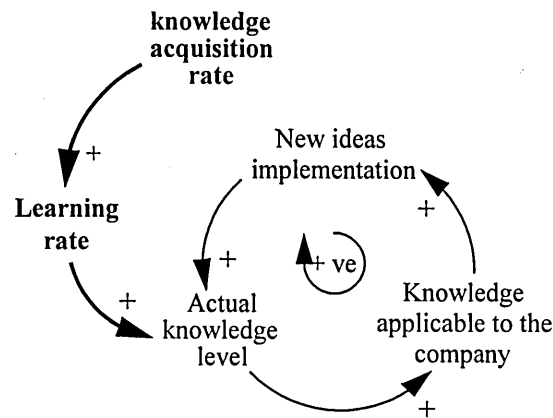

Figure 6.8: Causal-loop diagram representing knowledge and learning relationships.

For this study, the knowledge gap is a function of the actual knowledge reporting and desired knowledge level needed to conduct business in a new market or introduction of new product. Higher the desired knowledge level, higher the knowledge gap. Knowledge gap decreases with the progression of knowledge depository. The variables on this loop are, actual knowledge level \rightarrow knowledge gap \rightarrow knowledge acquisition rate \rightarrow learning completion rate, which then influences the actual or residing knowledge level as shown in Figure 6.9. This loop attempts to control the level of actual knowledge such that the gap between organisation's desired and its current knowledge level is minimised. If knowledge gap is being actively pursued by management policies, it enhances the rate of knowledge acquisition.

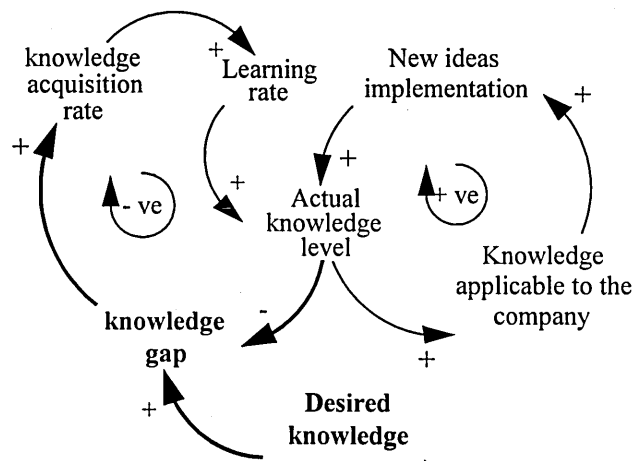

Figure 6.9: Causal-loop diagram representing flow of knowledge within organisation.

In reality present organisation knowledge could erode with time due to change in environment or people leaving the organisation taking important knowledge away with them. This additional influence may be represented using a feed-forward loop of knowledge erosion. This influence is between the knowledge erosion and the actual knowledge level as shown in Figure 6.10. More the knowledge erosion rate, the actual knowledge level decreases. The management needs to take appropriate action to maintain the needed knowledge through new recruitment and/or training existing employee.

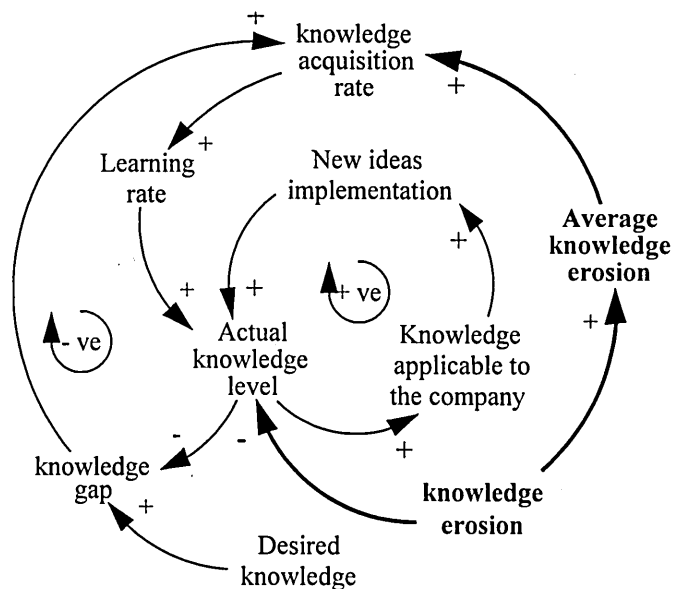

Figure 6.10: Causal-loop diagram representing knowledge acquisition and erosion

Knowledge in process, which is defined as the interpretation of information and understanding the data, increases the rate of acquisition knowledge. This rate of increase depends on the feedback of adjustment knowledge in process, which equal the difference between the desired knowledge in process and the actual knowledge in process as shown in Figure 6.11. Knowledge in process is affected by the learning rate and the knowledge acquisition rate. Knowledge in process also influences the actual knowledge level as it identifies the gained knowledge over the learning time and feedback that gained to the knowledge acquisition rate.

As explained in Chapter 4 the second wave summarises learning processes that lead to a modification of organisational norms or standards and challenge the existing knowledge (Figure 6.11). Within this process, single-loop learning is the foundation of double-loop learning as shown in Figure 6.1. Compared with the conventional control of divergences, used in single-loop learning, a modification of governing values also becomes feasible (Probst & Buchel, 1994; Wright, 1997). The simplified causal-loop diagram shown in Figure 6.11 illustrates the major feed-forward and feedback loops.

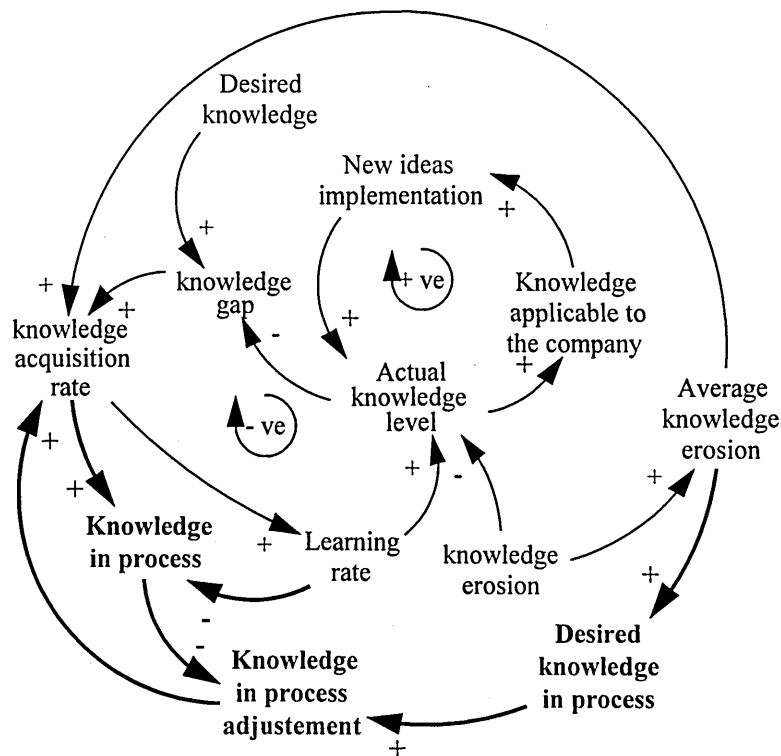

Figure 6.11: Causal-loop diagram of second wave of quality

6.3.3 Third wave influence diagram

As in Chapter 4 the third wave prescribe for a complete change and renewal. This requires an individual to reflect on his/her mental models by challenging it, thereby learning to learn new things. Increasing/decreasing the learning rate in this context is attributable to external teaching (consulting) and internal training as shown in Figure 6.12. Also training needs depends on learning rate and internal training. Increasing training needs increases the internal training. But increasing the learning rate would decrease the organisation's needs of training. From this perspective, increase the learning rate would increase the knowledge and skill development as shown in Figure 6.13. Knowledge and skill development are fundamental to organisational competence. The competence pool is defined as the set of skills and knowledge that an individual needs in order effectively to perform a specified job.

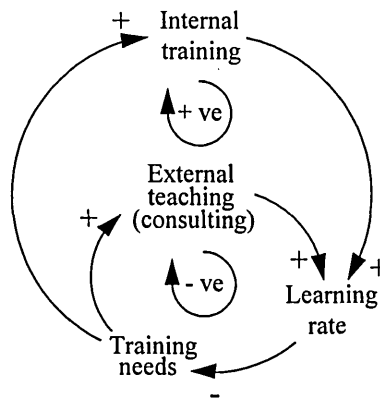

Figure 6.12: Causal-loop diagram representing the learning and training relationships.

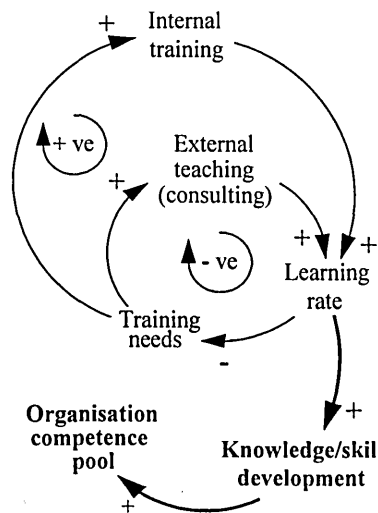

Figure 6.13: Causal-loop diagram representing knowledge/skill development relationships.

Competence gap is defined as the difference between the desired value of competence pool and the actual one. This would eventually lead to reduce the training needs, which should further increase the importance of learning. The feedback from the competence gap would control the learning rate through the adjustment of the competence correction rate as shown in Figure 6.14.

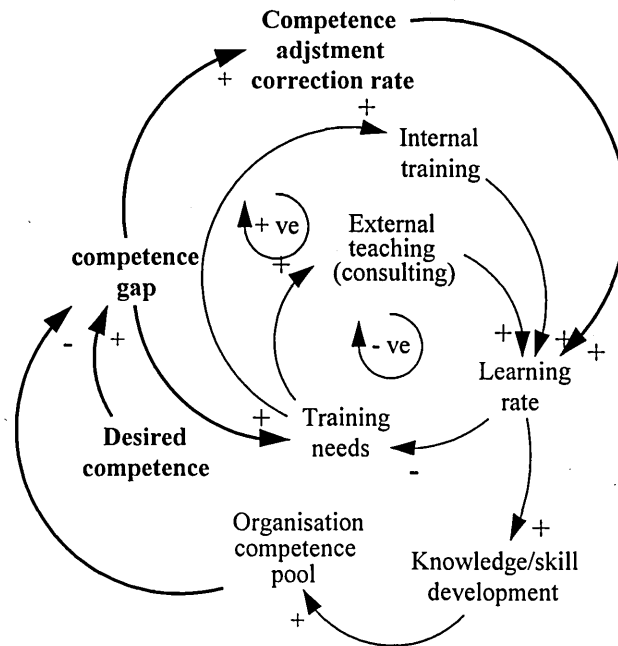

Figure 6.14: The effect of competence gap on competence pool

Another link is presented as a feed-forward to the learning rate. This link is between the present competence loss and the actual competence pool. The competence loss is defined as, decreasing the ability to implement and understand the knowledge/skill development to a work activity. Higher the competence loss would decrease the actual competence pool as shown in Figure 6.15.

Competence under development is the evidence that links the learning rate with the knowledge/skill development that would place it as part of a feedback loop. The adjustment competence in process is driven by the difference between the desired competence in process and the actual value of competence in process. The adjustment value of competence in process is feedback to control the learning rate as shown in Figure 6.16.

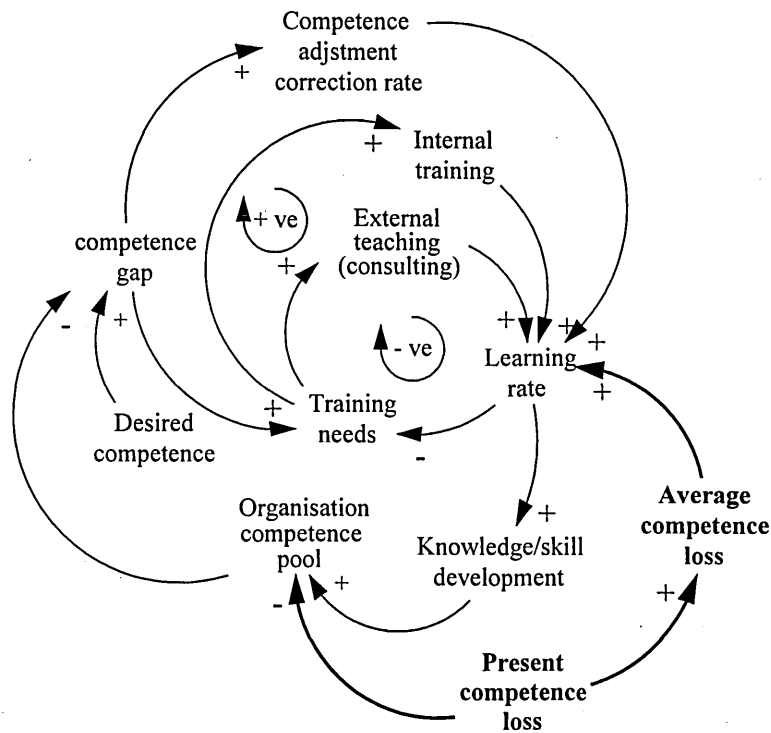

Figure 6.15: Causal-loop diagram of competence pool with the effect of the present competence loss

Figure 6.16 shows the feedback and feed-forward loops of the third wave of quality. A simplified balancing loop is consciously used to develop the feedback to competence pool. This loop variables are competence pool → competence gap → competence adjustment correction rate → learning rate → knowledge acquisition which completes the loop by impacting on competence pool. This loop attempts to control the organisation's level of competence such that the gap between desired and its current competence level is minimised. Another balancing loop is related to the effect of training on organisation competence. This loop variables are, competence pool → competence gap → training needs → external teaching (consulting) → learning rate → knowledge acquisition, which closes the loop by influencing the level of competence pool.

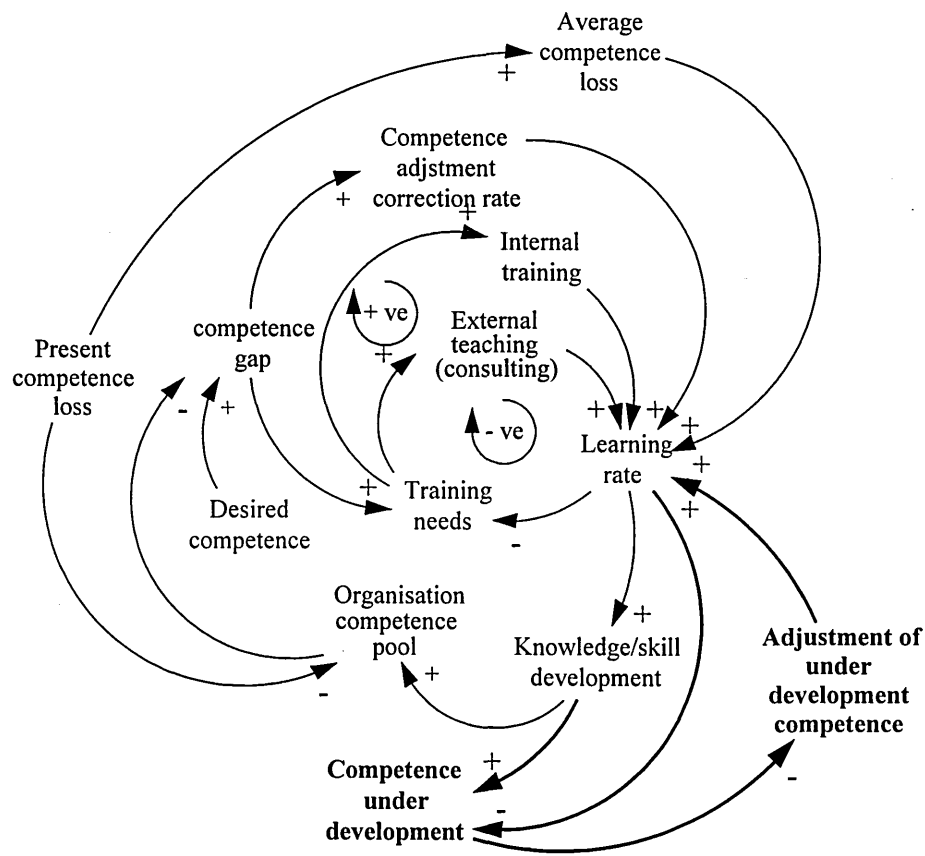

Figure 6.16: Causal-loop diagram representing the third wave of quality

6.3.4 Summary of the three waves

From a system dynamics point of view, the outputs of the causal-loops or influence diagrams as described above are similar to what one would expect at the end of a typical conceptualisation phase with a model building exercise. System dynamics have employed various approaches to facilitate the front-end of the modelling process in different settings (Senge, 1990 and Richardson & Steinhurst, 1992). The purpose of many conceptualisation efforts is seen as the beginning steps towards the development of a system dynamic computer model. The purpose of the methodology outlined above, however, is to help elicit an individual's understanding of an issue and map it out in a systemic representation. A major distinguishing feature of this methodology relative to many other methods used for conceptualisation is the relative representation and heavy focus on an inductive process at the very front end. Causal-loop diagrams are not intended to provide mathematical specification of the relationships, which may be linear or non-linear, and may include time delays between cause and effect.

6.4 Simulation analysis

Skill, knowledge and competence, as a measure of improvement, cannot be bought and delivered instantly. It takes a considerable amount of time to develop and support infrastructure. As shown with the causal-loop diagrams, the scope of the model is too large if one were to measure the performance of an organisation in all aspects. Therefore a simplified model is constructed to focus the dynamic response of one key variable i.e. skill. The skill base of an enterprise can rise as a result of training. The skill can be removed or loss if people leave an organisation. This loss has to be replaced either by new recruitment or by training and development within the existing workforce. These two are time consuming and costly activities.

The Skill Pool Model (SKPM) is developed to help understand the dynamics of skill acquisition and retention, particularly during times when an organisation is going through major change. This model implicitly link with the organisation environment to show how new skills would improve the organisation productivity and would develop new product. Also it aims to respond to the training and learning needs as a result of present skill loss rate (feed-forward) as well as skill level and training performance (feedback).

6.5 The Skill Pool Model (SKPM)

The Skill Pool Model (SKPM) is adapted from the Inventory and Order-Based Production Control System (IOBPCS). The IOBPCS model has been identified by Coyle (1977) as representing much of UK's industrial practice associated with manual production control systems. He simulated the response of this system to a range of dynamic inputs and selected optimum parameter values using some empirical procedure. Coyle stated that the model described many industrial systems, which also involve human experience. Towill (1982) shows how the IOBPCS model can be shaped to satisfy those conditions under which analogous linear control systems for other applications have been regarded as optimum. Hafeez *et al.* (1994 & 1996) have shown its usefulness for modelling supply chains.

The IOBPCS forms the basis of a generic family of production control systems whose behaviour has been tested against the performance of sectors of UK industry (Edghill, 1990). The model makes use of feed-forward information, with regards to ordering trends and variance and target customer service level, and the feedback of information

on finished goods stock, and product lead-times (Cheema *et al.*, 1989). Relevant conceptual and block diagram of the IOBPCS model are given in Appendix 6.1. Appendix 6.2 illustrates the variation of the actual IOBPCS model for a range of scenarios (Ferris and Towill, 1993).

6.5.1 SKPM block diagram

The influence diagram for SKPM is shown in Figure 6.17. For organisations to anticipate the skill loss replacement requirement in future, some kind of forecasting is useful. Therefore the present skill loss rate is exponentially averaged over a time T_a and added back to the original training rate as illustrated in a block diagram form Figure 6.18. The forecast expected skill loss rate is referred to as an inertial component of the system as shown in Figure 6.18.

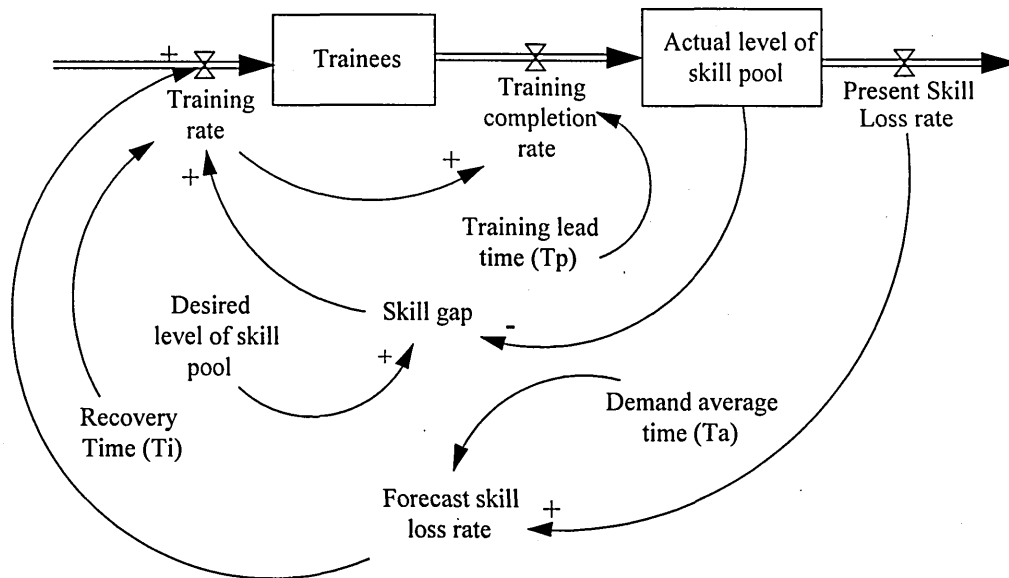

Figure 6.17: Influence diagram of SKPM.

Figure 6.18 illustrate that the organisation-training rate comprises two parts. One is due to the present skill deficit/gap, and the other due to the forecast skill loss rate. Training rate is therefore effectively controlled via T_a (the average time to determine the forecast skill loss rate), and T_i (the time over which the present skill gap is to be recovered). The difference between the present skill loss rate and recruitment or skill development rate, the change in acquired skill is accumulated to give the present actual level of skill pool. Finally, the skill gap is determined by subtracting actual level of skill pool from the desired level of skill pool. Therefore the model as shown in Figure 6.18 consists of two

parts; feedback control based on skill gap and the feed-forward control based on the forecast skill loss rate.

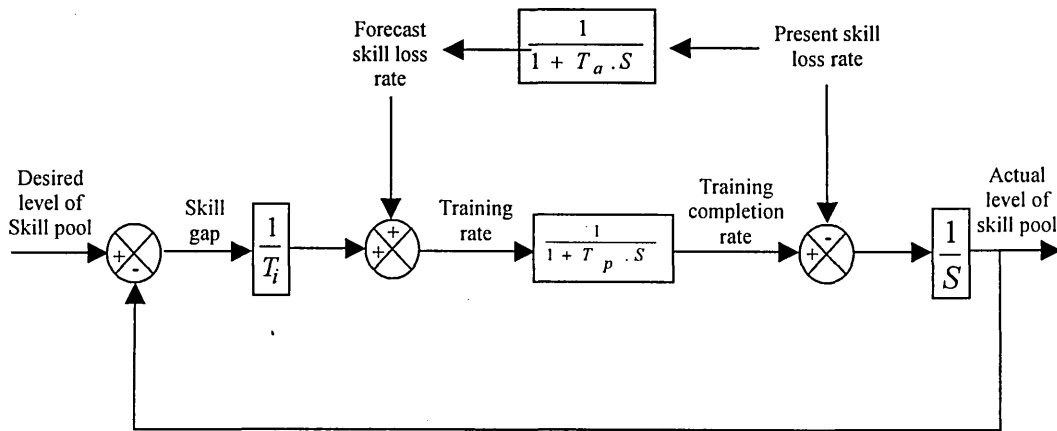

Figure 6.18: A block diagram representation of SKPM.

As shown in Figure 6.18 the policy parameters T_i , T_a and T_p are needed to be varied to determine their optimum settings using simulation results. Once selected, the system operates with the recruit skill rate automatically governed by T_a and T_i for a present skill loss rate and skill gap. During normal operation, the management would observe skill gap and training completion rate to meet the organisation's requirement.

The main blocks and flows of the SKPM block diagram as shown in Figure 6.18 are: -

- Present skill loss: it is a rate of losing skill due to staff leaving or skill obsolescence and it refers to present loss rate. The units of skill loss rate are skill unit/week.
- Forecast skill loss: it is a time average of skill loss rate and refer forecast loss rate. The units of forecast skill loss rate are skill unit/week.
- Desired level of skill pool: it is a level of a desired skill pool so it is a target. It refers to desired pool levels. The unit of desired level of skill pool is skill unit.
- Skill gap: it is the difference between the desired level of skill pool and the actual level. The unit of skill gap is skill unit.
- Training rate: it is a demanded training rate and it refers to the present skill loss rate. Skill unit/week are the units of training rate.
- Training completion rate: it may refer to skill acquisition rate. Skill unit/ week are the training completion rate units.

Actual level of skill pool: it is the actual skill pool an organisation needs to run its daily operation. The units are skill unit.

$$\frac{1}{T_i}$$

It is the proportional constant to deal with the discrepancy between the desired and actual values of skill. T_i is used in the control algorithm determining the training rate placed in the light of any skill stock discrepancies from the desired level.

$$\frac{1}{S}$$

This represents the level of skills pool accumulated over time through the training development and imported by the present skill loss rates.

$$\frac{1}{1 + T_p \cdot S}$$

It is the training process to acquire skill during the training session or overall development time (T_p). T_p is the actual learning and training lead-time.

$$\frac{1}{1 + T_a \cdot S}$$

It is the process to average the skill loss rate over the demand average time (T_a). T_a refers to exponential smoothing time over which skill loss has been averaged.

6.5.2 Transfer function of SKPM

The simulation of time varying system requires the solution of differential equations (when written as a function of continuous time), or difference equations (when written as a function of discrete time). The ready availability of cheap digital computing power means that the solution of difference equations is now a matter of routine. This means that except in the case where real-time simulation of relatively fast systems is required, the problem will be written in difference equation form even if the real system operates in continuous time (Daves, 1984).

Figure 6.18 shows the block diagram representation of the key variables of the model and their interactions. Equations (6.1) to (6.5) outline the main structure of SKPM in terms of its variables. Equation (6.1) calculates the skill gap as the difference between a fixed or constant desired level of skill and the actual level of skill pool.

Equation (6.5) shows the forecast skill loss rate as a smoothing function, $[1/(1+T_a S)]$, of the present skill loss rate. The later are then used to derive the scheduled training rate in Equation (6.2). The schedule aims to meet the forecast skill loss rate but adjusts this target to take into account current skill gap. The adjustment is given by function $(1/T_i)$ representing a control algorithm as shown in Equation (6.3). The training completion rate is given as the result of delaying function $[1/(1+T_p S)]$ of the schedule-training rate in Equation (6.3). Finally in Equation (6.4) the actual level of skill level is shown as the accumulation onto its previous level, function $(1/S)$ of the training completion rate less present loss rate. These equations can be written down directly from Figure 6.18 using the control theory.

$$SKG = DLSKP - ALSKP \quad (6.1)$$

$$TRATE = SKG \cdot \left(\frac{1}{T_i} \right) + FSKLR \quad (6.2)$$

$$TCRATE = TRATE \cdot \left(\frac{1}{1 + T_p \cdot S} \right) \quad (6.3)$$

$$ALSKP = \left(\frac{1}{S} \right) \cdot (TCRATE - PSKLR) \quad (6.4)$$

$$FSKLR = PSKLR \cdot \left(\frac{1}{1 + T_a \cdot S} \right) \quad (6.5)$$

Equations (6.1) to (6.5) are solved to develop actual level of skill pool/present skill loss rate transfer function (Equation 6.6), and actual level of skill/training completion rate (Equation 6.7) as shown in the following: -

$$\frac{ALSKP}{PSKLR} = -T_i \left[\frac{(T_p + T_a) \cdot S + T_p T_a S^2}{(1 + T_a S)(1 + T_i S + T_i T_p S^2)} \right] \quad (6.6)$$

$$\frac{TCRATE}{PSKLR} = \frac{1 + (T_i + T_a) \cdot S}{(1 + T_a S)(1 + T_i S + T_i T_p S^2)} \quad (6.7)$$

Equations (6.6) and (6.7) are extremely useful in understanding how the two parameters T_i and T_a , to be set by the system designer, interact and affect the actual level of skill pool dynamic recovery pattern. If the feed-forward component is removed, so that the

control law is actual level of skill pool only based, then application of the Final Value Theorem shows that there is steady-state skill deficit of T_i for a sudden unit change in present skill loss rate. With the feed-forward component added, it may be similarly shown that this deficit is eliminated. Equations (6.6) and (6.7) are the form required if the recovery is to be calculated via standard Laplace Transform Tables, such as those provided by Barbe (1963).

6.5.3 System performance indices

Any system evaluation requires measures of performance to determine the system behaviour. In the case of SKPM it has been decided to highlight the actual skill level (Equation 6.6), and training completion rate (Equation 6.7). The selection of performance criteria for particular applications may be subject to much debate, which is one reason why they must be agreed as acceptable prior any analysis. Dorf (1989) discussed the importance of the selection of appropriate criteria. Dorf defines the performance index as a quantitative measure of the performance of a system and is chosen so that due emphasis is given to important system specification. In order to evaluate SKPM the performance indices are shown respectively in Figures (6.19) and (6.20).

6.5.3.1 Skill level measurements

Figure 6.19 shows the time response for a typical SKPM plot with selected performance measures. The system shows the characteristic skill pool droop, which then recovers and eventually attains steady state. The following characteristic properties are important for this analysis.

- Initial skill pool droop (Y_1)

A step increase in present skill loss is used to induce a transient in the model and an initial drop in the skill level is observed. This is due to initial loss being compensated from skill level whilst extra recruit skills are being acquired on the training session. It is important to measure this droop (Y_1) so as to minimise the probability of skills obsolescence. An obvious way of eliminating this problem is to hold large number of skilled staff, but this has the detrimental affect on the overheads and there is a real risk of skill obsolescence.

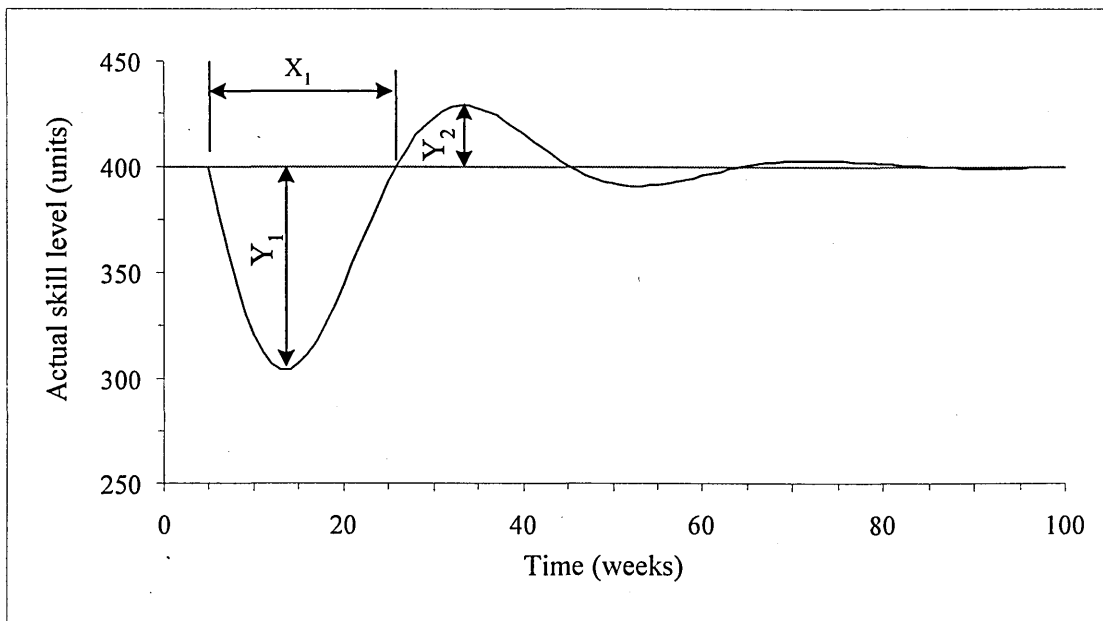

Figure 6.19: Skill level measurements

- Duration of the skill pool deficit (X_1)

The duration of the skill pool deficit (X_1) gives an indication of speed of recovery from the skill pool deficit. This is calculated by looking at the time it takes for the skill pool level to return to its initial value after the skill pool droop.

- Peak skill pool overshoot (Y_2)

The peak skill pool overshoot (Y_2) is an illustration of how well the skill pool control laws are behaving. A large overshoot would mark itself as low skill level turnover. The overshoot is therefore an essential measurement both in satisfying the organisation needs and also in having an efficient level control policy. For the purpose of simulation, it is measured by looking at the difference of the peak overshoot value and the initial skill pool level.

6.5.3.2 Training completion rate measurement

Figure 6.20 shows a typical training completion rate time response showing an initial rise with an overshoot and finally reaching steady state.

- Rise time (X_2)

The smoothing response of the step input system can be measured by its rise time (X_2). For the purpose of the analysis, the rise time is considered to be the time taken to first attain its final value that is zero to 100% Dorf (1989). A measurement of rise time will

give the manager a useful indication of how long it will take to first hit the steady training completion rate and hence refill demand service shock.

- Peak overshoot (Y_3)

A peak overshoot (Y_3) will only occur with an under-damped system and it's defined as the maximum value of the output to a step change in its input. For the purpose of analysis, the definition of peak overshoot is the difference of the maximum value of training completion rate from its final steady state value. To achieve a level of good management control, large overshoots are to be avoided as they put an undue strain on trainee capacity. A small overshoot has to be balanced against a rise time that is not excessively long, hence the designer must find a compromise between the two.

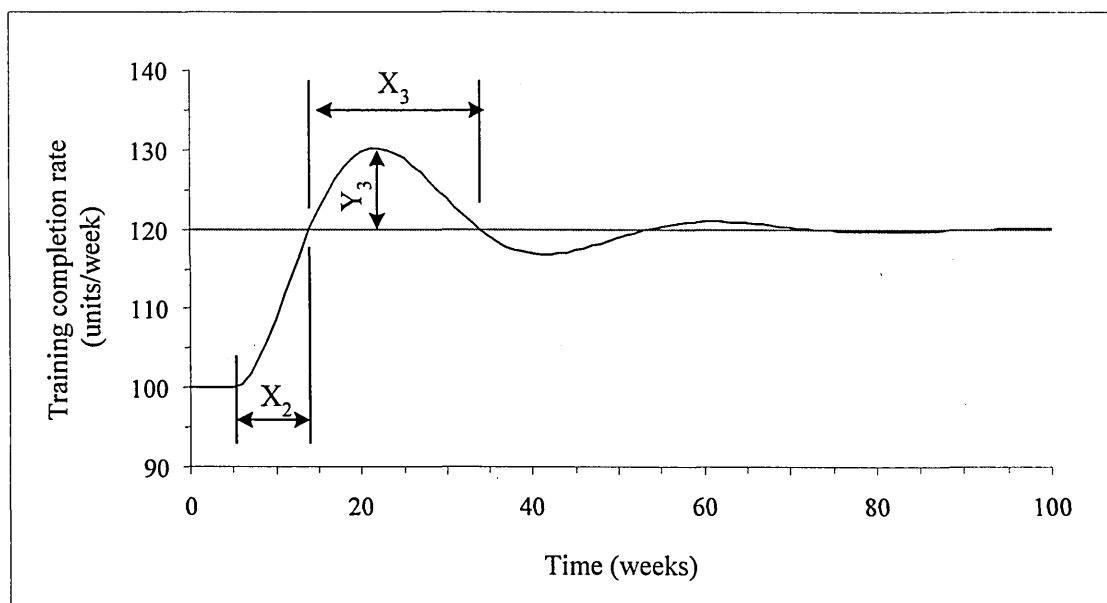

Figure 6.20: Training completion rate measurement

- Duration of overshoot (X_3)

The duration of overshoot (X_3) is an important measure to see the length of time the system is over trainee. This will manifest itself in large skill levels and a poor level turnover ratio. In the analysis the duration of overshoot is calculated between the times the peak overshoot starts and finishes.

6.5.4 Dynamic behaviour analysis

It is important to recognise that how to manage actual level of skill pool. To reach the desired value, a policy must be defined by which to achieve this. A simple and

appropriate policy for this is proportional control, where information concerning the magnitude of the level (actual level of skill pool), is feedback to control the training rate. The training rate is calculated by dividing the discrepancy between the desired and actual value of the level by a time factor, which represents the average delay in performing the training rate.

The assumption is that recruits will be taken on as available and that the delay in recruitment will vary about the average due to variation in the time of response to acquire the new skill, training time, and availability of skill. All these factors could be explicitly modelled but are combined here for simplicity under an average recruitment delay.

However to analyse the skill pool model dynamic response it is needed to find a suitable way of describing the process delays, which exist within the system. In other words, how to represent the practical effect of T_p (training lead time) and T_a (averaging time for forecast skill loss rate) in difference equation form. Towill (1982) has found the exponential delay particularly suitable for industrial dynamics simulation, and so it is the discrete version which be used in SKPM. Delays are a major feature of dynamic behaviour and are illustrated in Appendix 6.3.

The pool of skill is initially made equal to the value of desired level of skill (400 unit of skill per week). A skill drop of 20% is implemented at time 2 weeks. Figure 6.21a shows the actual skill level response of the model to a step input in the present skill loss rate. When the present skill loss rate is suddenly increased the actual skill level falls as shown in Figure 6.21a but this in turn causes the present skill loss rate to fall. The simulation is implemented using *ithink* simulation package.

Figures 6.21 examine the step response of the skill pool level and training completion rate depends on the influence of the parameter T_i whereas T_a , and T_p are time constants (4 weeks). As shown in Figure 6.21a, the largest value of T_i gives the largest droop in the skill level at the initial, which means larger risk of obsolescence. But the smallest value of T_i explored in the Figures reverses this trend, protecting skill level, and in so doing, creates an oscillatory response. Yet smaller values of T_i would induce instability in a real system. The characteristic in these responses is an acceptable drop in skill

levels whilst satisfying the initial increase in skill loss. This is then followed by a recovery facilitated by increased the training completion rate.

The duration of the skill pool deficit increases for high values of T_i . It gives an indication that recovery takes longer with the increasing of T_i . Also increasing T_i would decrease the peak skill pool overshoot. It illustrates how well the skill pool control laws are behaving. It should also be noted that increasing T_i gave a linear development in response characteristics.

Figure 6.21b concentrates on the influence of T_i on the training completion rate. Clearly the largest value of T_i gives the smoothest training completion rate. But at lowest value of T_i some oscillation would occur, which indicates the system is under-damped. Managers tend to be more concerned to avoid larger overshoots than to deal with the rise time. In other words, increasing overshoot would decrease rise time but smaller overshoots reverse this trend. Also increasing T_i would decrease the duration of overshoot as shown in Figure 6.21b.

Figure 6.22 shows the influence of T_a , the parameter reflecting the exponential smoothing coefficient to forecast skill loss rate. The distinctive skill level droop is again evident but with less oscillation than the effect of T_i . Figure 6.22a, shows that the actual skill level responses indicate that as T_a increase the overshoot is damped down, although there is a corresponding increase in settling time. Figure 6.22b illustrate the training completion rate responses for a step input. The aim is to observe how the system recovers to such an input. The training completion rate shows that with increasing T_a the overshoot slightly decrease while there is slight increase in the duration of overshoot time. Decreasing T_a , the rise time or the dynamic recovery to the input improves. Also to note is the narrower range of behaviour demonstrating that the feedback path design discussed above is the most influential. and thus of primary importance rather than the feed-forward path in which T_a is the controlling parameter.

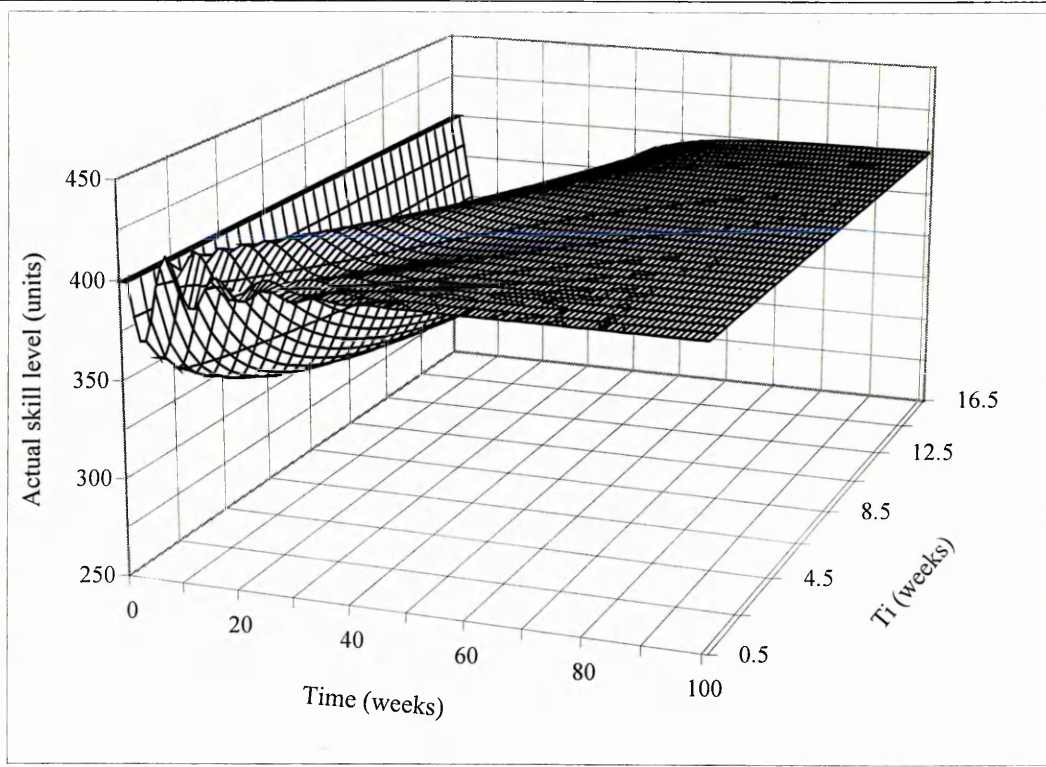

(a) Skill level behaviour ($T_p = T_a = 4$ weeks)

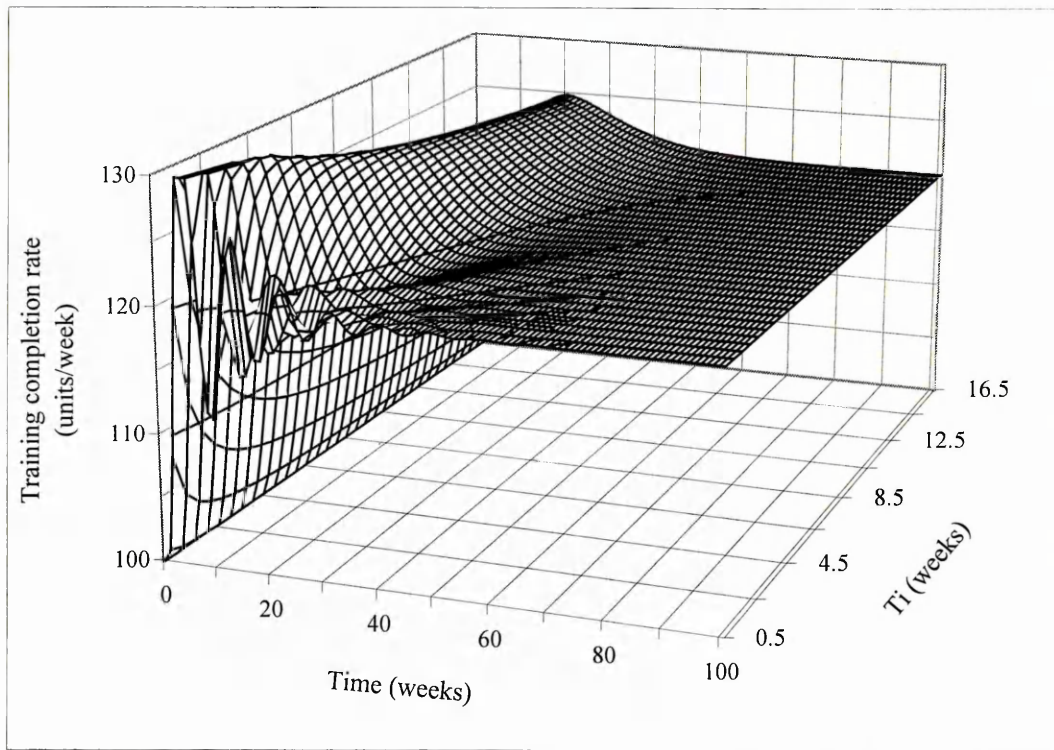

(b): Training completion rate behaviour. ($T_p = T_a = 4$ weeks)

Figure 6.21: Step response of SKPM for varying values of T_i .

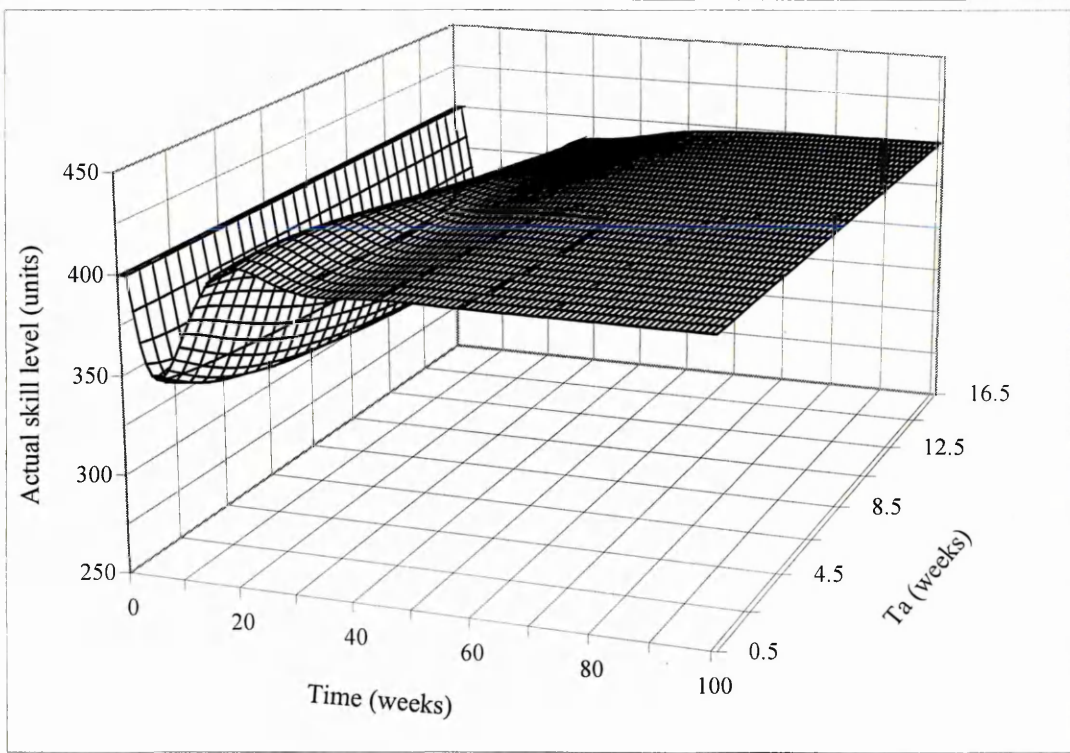

(a): Skill level behaviour ($T_p = T_i = 4$ weeks)

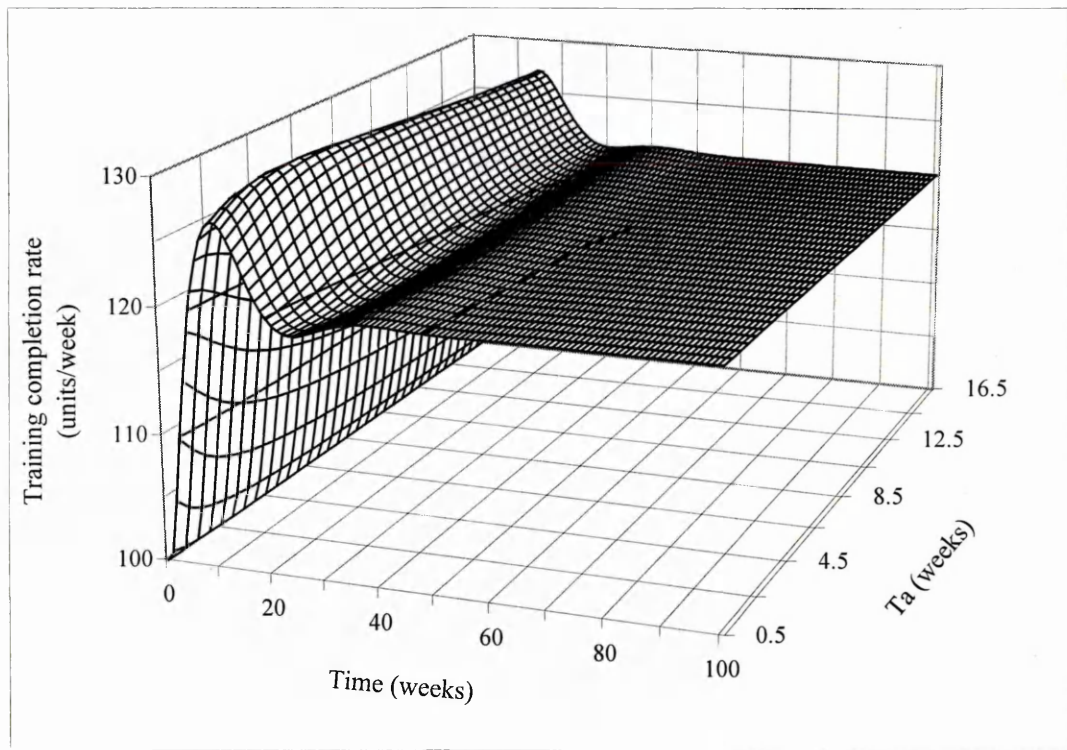

(b): Training completion rate behaviour. ($T_p = T_i = 4$ weeks)

Figure 6.22: Step response of SKPM for varying values of T_a .

Figure 6.23 shows the actual skill level and training completion rate response while varying the lead-time/training time T_p . As shown in Figure 6.23a, reducing T_p improves the system response to the step up in skill loss. But increasing the T_p causes the system to be more oscillatory. As shown in Figure 6.23b, increasing T_p would increase the system oscillation, as well as increase the settling time. Whereas the changes in the rising time are slightly the same.

The second and third waves models follow exactly the same simulation patterns. These two waves influence and block diagrams respectively are presented in Appendix 6.4.

From the presented results, the question of which values of T_i , T_a related to T_p yields the best performance. Towill (1982) optimise the IOBPCS model using the “trade off” between the given parameters. Translating those into the present model would give rise to the following optimisation guidelines: -

- Good skill pool recovery in response to changes in skill loss
- Good training completion rate in response to skill loss changes including the ability to attenuate fluctuations that lead to increased training on-cost.

The SKPM optimum is stated as $T_i = T_p$ and $T_a = 2 T_p$ at $T_p = 4$ weeks. It should also be noted that the response of the actual skill pool, as shown in Figures 6.21, 6.22, and 6.23, at the optimum values are the recovery rate to skill changes is marginally the lowest. Also at the optimum values these Figures show the response of the training completion rate rising to reflect the organisation skill loss, and less the worst training completion overshoot. The latter is explained theoretically because the skill level droop that is being recovered during the peak training completion rate is the least at the optimum value of design parameters. Table 6.2 summaries the effect of T_i , T_a , and T_p on the measurement of performance indices.

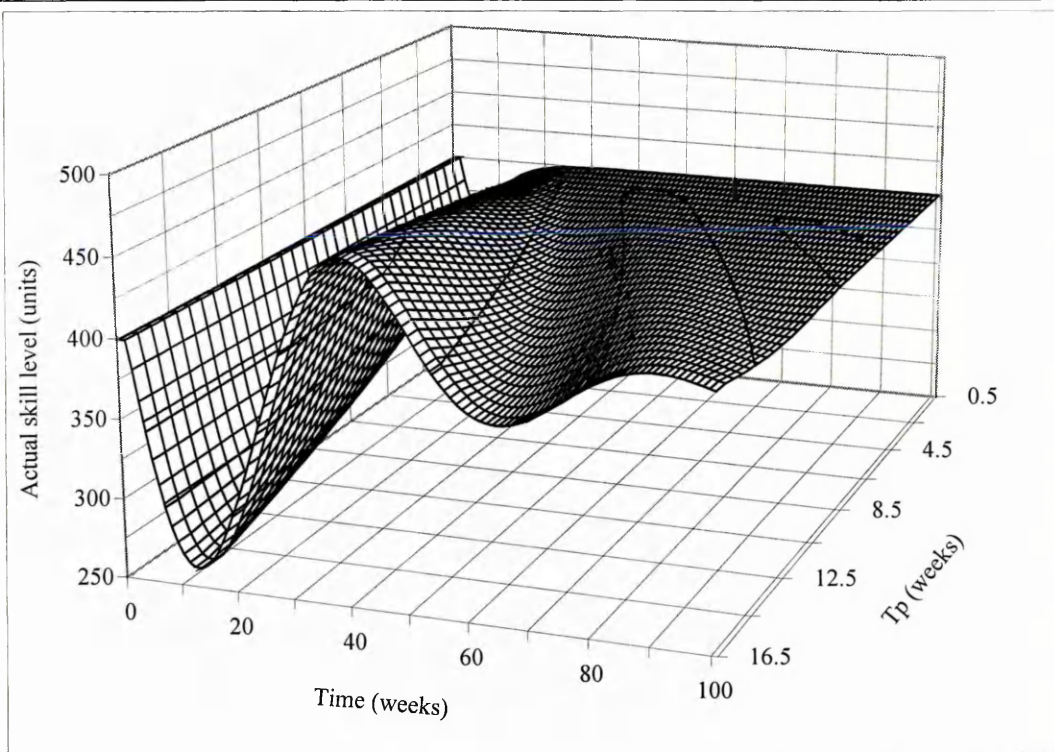

(a): Skill level behaviour ($T_a = T_i = 4$ weeks)

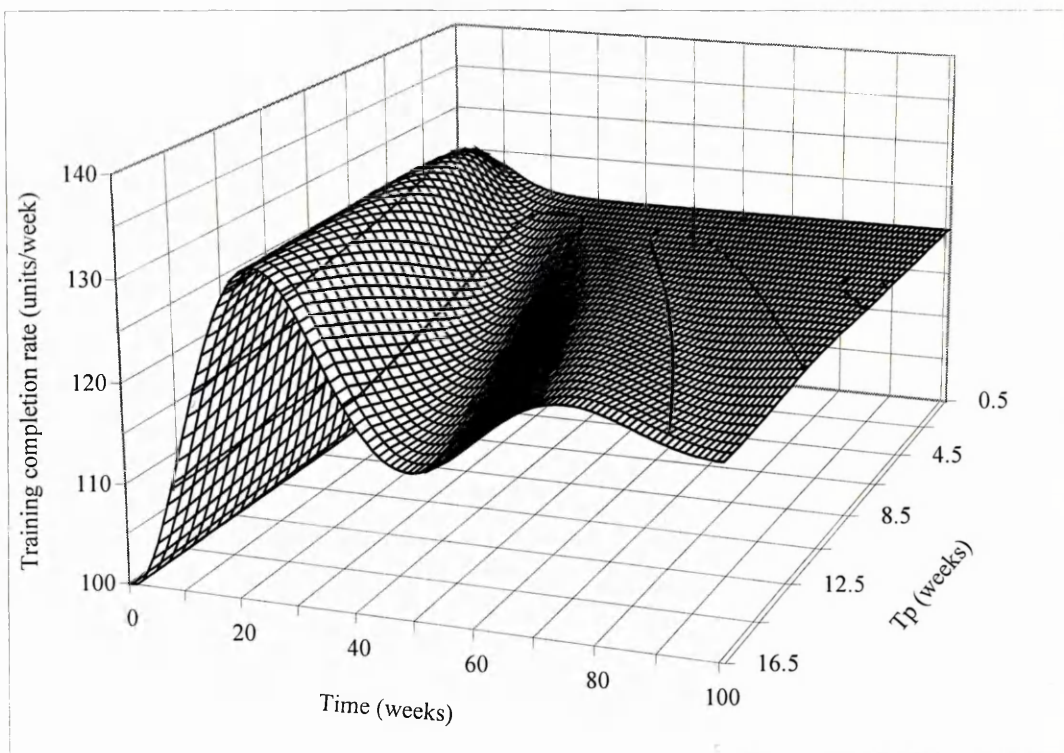

(b): Training completion rate behaviour. ($T_i = T_a = 4$ weeks)

Figure 6.23: Step response of SKPM for varying values of T_p .

Performance index		SKPM parameter			Performance index at the optimum design parameters ($T_i = T_p = 4$ weeks and $T_a = 2T_p = 8$ weeks)
		T_a	T_i	T_p	
Skill level measurements	Initial skill pool droop	Increasing T_a increases the initial skill pool droop.	Increasing T_i increases the initial skill pool droop.	Increasing T_p increases the initial skill pool droop.	20.37%
	Duration of the skill pool deficit	Increasing T_a increases the settling time	Increasing T_i increases the settling time	Increasing T_p increases the settling time	22 week
	Peak skill pool overshoot	Increasing T_a decreases the peak skill pool overshoot	Increasing T_i decreases the peak skill pool overshoot	Increasing T_p increases the peak skill pool overshoot	0.46%
Training completion rate measurements	Rise time	Increasing T_a increases the rise time	Increasing T_i slightly increases the rise time	Increasing T_p increases the rise time	8 weeks
	Peak overshoot	Increasing T_a decreases the peak overshoot	Increasing T_i slightly increases the peak overshoot	Increasing T_p increases the peak overshoot	6.94%
	Duration of overshoot	Increasing T_a increases the duration of overshoot	Increasing T_i slightly increases the duration of overshoot	Increasing T_p increases the duration of overshoot	16 week

Table 6.2: Summary the effect of T_i , T_a , and T_p on the measurement of performance indices

6.6 Summary

In practice, most organisations are focused on the single-loop learning, which aim to get organisation skilled in their work and create competitive advantages based on these skills. Single-loop learning is the first step to understand the organisational learning especially learning among front-line workers. These workers typically rely more heavily on skill acquisition.

The skills and capabilities of learning organisations are the capacity of individuals, teams, and eventually larger organisations to orient toward what they truly care about, and to change because they want to, not just because they need to (Senge, 1990). According to Senge, the category of learning skills is the motivation to learn and improve. This includes having time for learning, learning objectives, interest in learning, etc. Management commitment for learning tasks is also one of the aspects that fall under aspiration.

Managers are more likely to be concerned with managing the desired parameter (T_i , T_a , and T_p) of learning behaviours that exist in a large workforce. In this situation, manager can use the optimum values of the parameter to control the difference between the current reality and a desired future. The gap between the current reality and the desired future should not be too large, because the objectives of the organisation become too abstract and concrete actions towards improvement are not clearly visible. On the other hand, the gap between current reality and the desired future should not be too small either, because this will result in no action at all, since the need for action might seem unnecessary. This creative tension principle indicates to set reachable objectives for learning.

The situation remains relatively straightforward in terms of gradual change due to slow change in the external environment and/or internal initiative like continuous improvement. In this case the skill loss rate can be counter balanced by increased training. However, the situation become more difficult to handle if staff turnover is significant at such times, particularly if replacements tend to have skill levels significantly lower. Training must then be relied upon to make up for shortfalls due to turnover, as well as with loss skill. In such times, clearly minimising turnover is going to be highly beneficial.

To improve the organisation-training dynamic response and to minimise the staff turnover an extra feedback term is added to SKPM. The pipeline policy and the automated pipeline policy are presented and discussed in next Chapter to improve the performance indices measurements.

6.7 Reference

- Anil B., (2000), "A systems thinking perspective of maintenance, operations, and process quality", *Journal of Quality Maintenance Engineering*, Vol. 6, No. 2, pp. 123-132
- Banker, R., Potter, G. & Schroeder, R., (1993), "Manufacturing performance reporting for continuous quality improvement", *Management International Review*, Vol. 33, PP. 69-85
- Barbe, E. C., (1963), "Linear Control Systems", Scranton: International Textbook Company, Appendix A3.
- Baker J.C., Mapes J., New C.C., Szwajczewski M., (1997), "A hierarchical model of business competence", *Integrated Manufacturing Systems*, Vol. 8 No. 5, pp. 265–272
- Burgess, T.F. (1996), "Modelling quality-cost dynamics", *International Journal of Quality & Reliability Management*, Vol. 13 No. 3, pp. 8-26.
- Coyle, R., (1977), "Management System Dynamics", Chichester, John Wiley & Sons
- Cheema, P., Towill, D. R., and Bishop, B., (1989), "A combined feed-forward/feedback 'to-make' model for a multi-product machine shop", *Proceedings of the 5th National Conference on Production Research*, Huddersfield Polytechnic, UK, PP. 101 – 105.
- Davies R., (1984), "Analogue Alternative", *Systems International*, Vol. 12, No.1
- Deming, W. E., (1986), "Out of the crisis". Cambridge: MIT Centre for Advanced Engineering Study, Cambridge, MA.
- Dorf, R. C., (1989), "Modern control systems", Published by Addison Wesley" pp. 150-153 (p125)
- Edghill, J. S., (1990), "The application of aggregate industrial dynamics techniques to manufacturing systems", Ph.D. Thesis, University of Wales College of Cardiff, Cardiff, Wales
- Evans J., and Lindsay W., (1996), "The management and control of quality", 3rd Edn. (Minneapolis, West)

- Ferris J.S., Towill D.R., (1993), "Benchmarking a generic family of Dynamic Manufacturing Ordering and Control Models", *J Syst Eng*, Vol. 3, pp 170-182.
- Fiol, C., & Lyles, M., (1985), "Organisational learning" *Academy of Management Review*, Vol. 10, pp. 803-813
- Forrester, J. W., (1961), "Industrial Dynamics" Cambridge, MA: The MIT Press.
- Garvin, D., (1995), "The process of organisation and management", Working paper #94-084, Harvard Business School, Boston MA 02163.
- Gene Bellinger, (1997), "Knowledge Management", Notes from a Presentation at the Knowledge Management Town Meeting at Documation, February, San Jose, CA.
- Hafeez, K., Griffiths, M., and Naim, M. M., (1993), "Use of statistical techniques in the dynamic modelling of an industrial supply chain", *Proc. 30th MATADOR Int. Conf.*, Manchester, UK, pp 413-420
- Hafeez, K., Griffiths, M., Griffith, J., and Naim. M. M., (1996), "System design of a two-echelon steel industry supply chain", *International Journal of production economics*, Vol. 45, pp 121-130.
- Juran, (1988), "Quality Control Hand book", Mc Graw - Hill
- Mohapatra, P., Mandel, P. & Bora, M., (1994), "Introduction to System Dynamic Modelling", India, Universities, Press.
- Probst, G. & Buchel, B., (1994) *Organisationales Lernen-Wettbewerbsvorteile der Zukunft*. Wiesbaden: Gabler.
- Purnendu M., Andrea H., and Amrik S., (1998), "A systemic approach to quality improvements: The interactions between the technical, human and quality systems", *Total Quality Management*, Vol. 9, No. 1, pp. 79-100.
- Richardson, G. and Steinhurst, W., (1992), "Group model building", in proceedings of the 1992 international system dynamics conference, Utrecht, The Netherlands: system dynamics society.
- Richardson, G. P, (1991), "Feedback through in social science and systems theory", Philadelphia: University of Pennsylvania Press.
- Richardson G.P. and A.L. Pugh, (1981), "Introduction to system dynamics modelling with DYNAMO, MIT Press, Cambridge, MA.
- Samson, D. & Terziovski, M., (1993), "Quality based vision for the Australian manufacturing sector", *Asia Pacific Journal of Quality Management*, Vol. 2, pp.10-29.

- Sanchez, Ron, Aime Heene and Howard Thomas, (1996), "Towards the theory and practice of competence-based competition", in *Dynamics of Competence-Based Competition: Theory and Practice in the New Strategic Management*, Ron Sanchez, Aime Heene and Howard Thomas, editors, Oxford: Elsevier.
- Schneiderman, A., (1988), "Setting quality goals", *Quality Progress*, April, 55-57
- Senge, P., (1990), "The Fifth Discipline: The Art and Practice of the Learning Organisation", New York, Doubleday.
- Towill D. R., (1982), "Dynamic analysis of an inventory and order based production control system", *INT. J. PROD. RES.*, Vol. 20, No. 6, PP 671-687.
- Winch G., (1998), "Dynamic visioning for dynamic environments", *Journal of the Operational Research Society*, Vol. 49, pp. 354-361.
- Wright, R. W. (1997). Tangible integration versus intellectual codification skills: a comparison of learning processes in developing logic and memory semiconductors. In R. Sanchez, & S. Heene (Eds.), *Strategic learning and knowledge management* (pp. 83–102). Chichester: John Wiley and Sons.

OPTIMISING DYNAMIC BEHAVIOUR OF SKILL POOL MODEL USING THE PIPELINE POLICY

7.1 Introduction

In order to improve the business results Sterman (1989) has emphasised the significance of the process pipeline control based on the work in progress. He sets out the premise that dynamic response of a system greatly improves by using a pipeline control policy based on work in progress. For this research work in process or pipeline delay concerns the training lead-time. In this particular case pipeline policy is concerned with how many people are undergoing training and what skills are on offer during the organisation's training programme. The skills in process or under development are a function of the expected skills loss rate and the time it takes to acquire skill i.e. training lead-time. However it is not proposed to update the system controller settings in real time during the robustness experiments: this accords with known industrial practice (Cheema, 1994, and Hafeez *et al.*, 1994).

During periods when there are deficiencies of skills, for example, after a step change in the skill loss rate, then it would be beneficial to increase the recruitment and/or training to account for the skill shortfall with the pipeline policy. However there will be periods when there are excessive skills in an organisation if the skill pool and present skills loss rate policies don't consider the effects of the time delays in the system.

It has already been proven that the addition of feedback loops can increase the robustness of a system (Horowitz, 1963). This has been confirmed by Towill (1981) for a number of commonly met practical system designs. In the skill control model pool feedback is provided to help counteract drift problems met with skill levels. Pipeline control is then referring to the act of taking into account resources already committed (that is, those in the pipeline) when determining the rate at which resources are to be committed in subsequent time periods. In a production system the amount of resource in the pipeline would be referred to as work in progress.

This Chapter discuss and analyse two models, the first one is the Pipeline Skill Pool Model (PSKPM), which is developed to improve the dynamic behaviour of the SKPM model by adding an extra feedback term to SKPM. However, for a step change in present skill loss rate this introduces a final value offset in the actual skill level. The second model is the Automated Pipeline Skill Pool Model (APSKPM). It is shown how the addition of an extra feed-forward path to PSKPM, representing the pipeline skills in process target value eliminates the actual level of skill pool offset problem.

7.2 The Pipeline Skill Pool Model (PSKPM)

Adapted from (Cheema, 1994) Pipeline Inventory and Order-Based Production Control System (PIOBPCS), Figure 7.1 illustrates the Pipeline Skill Pool Model (PSKPM). The PSKPM shown in Figure 7.1 allows suitable consideration of the pipeline to stabilise dynamic behaviour of the performance measurements. The terminology and nomenclature used are based on the baseline SKPM, which was developed in Chapter 6. This model has three controllers, skill loss, skill in process and skill pool.

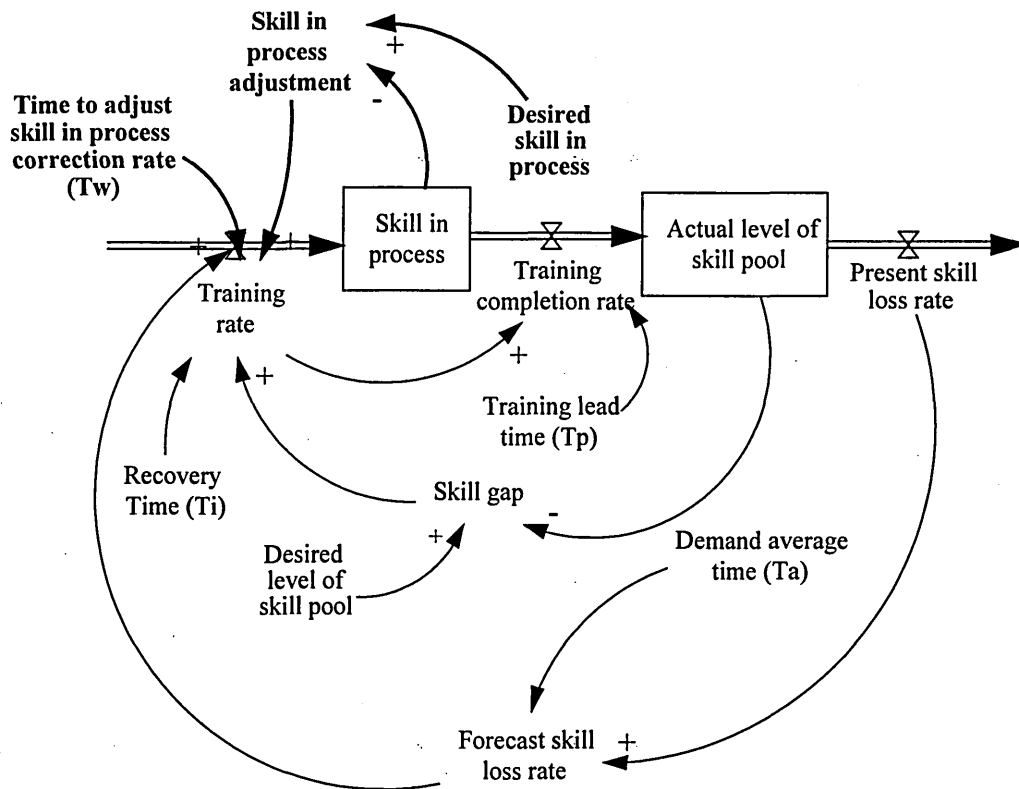

Figure 7.1: Influence diagram of PSKPM.

The purpose of simulation would be to show how these controllers affect the skills recruitment requirement, how they interact with each other, and how the emphasis can

be shifted from one controller to another by altering the values of T_i , T_a and T_w . The feed-forward of forecasted skills loss rate and skills pool and skills in process feedback loops are the main influences on the system. These are in turn greatly affected by the time to average skill loss, T_a , fraction $1/T_i$ and fraction $1/T_w$. The skill pool target and pipeline skills in process targets also affect the response, but only in the magnitude of the level in the system.

There are two important advantages in utilising skill under development feedback: On the one hand the benefits of obtaining better visibility of the pipeline. On the other hand it allows to cater for any change in the process pipeline due to skill obsolescence or disturbances are compensated for the number of experienced staff leave. The results depend on obtaining an accurate estimate of the training lead-time.

7.2.1 PSKPM block diagram

In comparison with the SKPM model, PSKPM consider the addition of a feedback loop to improve the dynamic performance. A block diagram representation of PSKPM with training lead-time is presented in Figure 7.2.

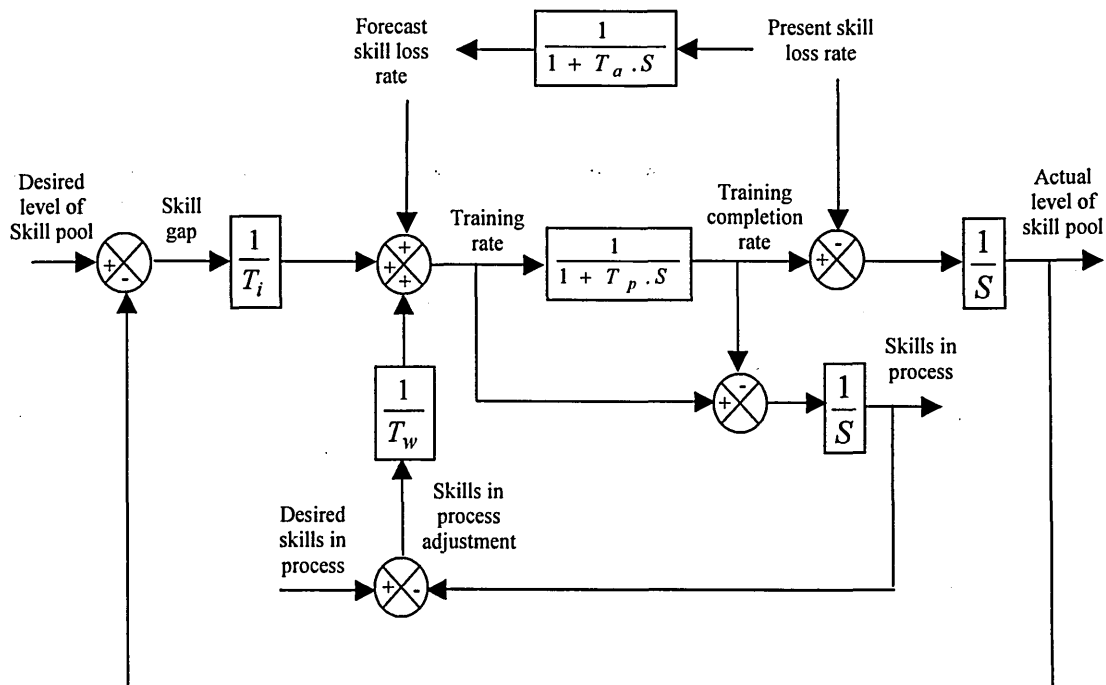

Figure 7.2: A block diagram representation of PSKPM.

In addition to the main blocks and flows described in section 6.5.1 for SKPM there are another four parameters as shown in Figure 7.2, as described in the following: -

- Skill in process:** is concerned with how many people are under an organisation's training programme. The unit of skill in process is skill unit/week.
- Desired skill in process:** it is a level of a desired skill in process so it is a target. It refers to skill obsolescence as well as the skill loss level due to the experienced staff leave. The unit of desired level of skill in process is skill unit.
- Skill in process adjustment:** it is the difference between the desired level of skill in process and the actual value. The unit of adjustment skill in process is skill unit.
- $\frac{1}{T_w}$ It is the proportional constant to deal with the skill in process adjustment. T_w is used in the control algorithm refers to time to adjust skill in process

7.2.2 Transfer function of PSKPM

The transfer functions for PSKPM can be derived using the block diagram analysis as shown in Figure 7.2. A detailed analysis is presented in Appendix 7.1.

$$\frac{ALSKP}{PSKLR} = -T_i \left[\frac{\frac{T_p}{T_w} + \left(T_a + T_p + \frac{T_a T_p}{T_w} \right) \cdot S + T_a T_p S^2}{(1 + T_a S) \left(1 + \left(1 + \frac{T_p}{T_w} \right) \cdot T_i S + T_p T_i S^2 \right)} \right] \quad (7.1)$$

$$\frac{TCRATE}{PSKLR} = \frac{1 + (T_a + T_i) \cdot S}{(1 + T_a S) \left(1 + \left(1 + \frac{T_p}{T_w} \right) \cdot T_i S + T_p T_i S^2 \right)} \quad (7.2)$$

$$\frac{SKIP}{PSKLR} = T_p \left[\frac{1 + (T_a + T_i) \cdot S}{(1 + T_a S) \left(1 + \left(1 + \frac{T_p}{T_w} \right) \cdot T_i S + T_p T_i S^2 \right)} \right] \quad (7.3)$$

7.2.3 PSKPM performance indices

For this model, the performance criteria measurements are the actual skill level, training completion rate and skill in process level. The first two measurement criteria are illustrated at section 6.5.3. Skill in process is an important measurement, which depends on the training delay. Therefore the total skill pool at a given time is the sum of skill inventory and the amount of skill acquired during the training programme. The training delay is a function of the actual training lead-time. Figure 7.3 shows a typical skill in process time response.

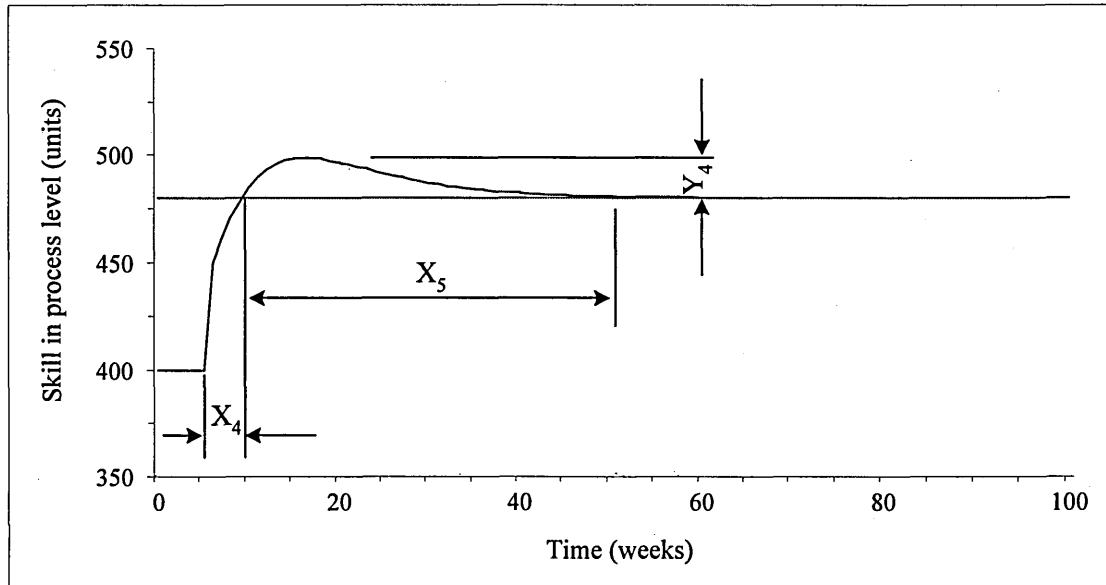

Figure 7.3: Measurement of skill in process criteria.

- Rise time (X_4)

The rise time is defined in similar terms to that of training completion rate (X_4 in Figure 7.3). The importance of measuring the rise time gives the management information at what rate skills are being developed in the training programme.

- Peak overshoot (Y_4)

The peak overshoot in the skill in the process is defined in similar terms to that training completion rate (Y_4 , Figure 7.3). A large value may imply training programme problems i.e., large lead-time and consequently more than desired skill levels.

- Duration of overshoot (X_5)

The duration of overshoot is defined in similar terms to that of training completion rate (X_5 , Figure 7.3). This measure will give a true picture of the problematic areas and inefficiencies in training programme.

7.2.4 Dynamic behaviour analysis

As discussed earlier, the addition of an extra feedback term to the original SKPM model i.e. decision rule based on expected number of staff in the training programme (PSKPM) improves dynamic performance. The simulation runs confirm that. For a step change in the present skill loss this introduces a final value offset in the actual skill level. This creates a constant deficiency of skill pool in an organisation. Therefore with the PSKPM the skill gap is never recovered and there is the associated risk of skill obsolescence due to the fixed value of desired value of skill under development.

In order to simulate dynamically the design parameter must be identified. Appendix 7.2 provide some guidance how the design parameters T_a , T_i and T_w to be set by the system designer. It can be seen that for $T_i \geq 10$ the value of ζ is greater than one (i.e. the system is over damped). Therefore the design parameter T_i is set as $0 < T_i \leq 10$. Whereas the parameter settings for T_w ranging $0 < T_w \leq 16$ have ideal values of ζ . The following section investigates the performance criteria of the PSKPM using the values of the design parameters as $1 \leq T_i \leq 8$ and $1 \leq T_w \leq 16$. These parameters settings give values of $\zeta \approx 0.75$, which is within the standard acceptable system design criteria.

The response to a step change is of importance not only because it gives a shock to the system but also additionally it is an input that is easily visualised (the response of which are also easily interpreted) and determines the basic dynamic characteristics of the system (Edghill, 1990). The system behaviour to this step change for actual skill pool, training completion rate and skills in process for PSKPM is present by varying the design parameters T_i , T_a , and T_w , between “0.5” to “16”. The simulation is implemented using *itink* simulation package, and the simulation equations are given in Appendix 7.3.

Figure 7.4 shows the effect of T_i on the actual skill pool level, training completion rate, and skills in process, following a step increase in the skill loss rate from 100 to 120 units/time at time = 2 weeks. This may be attributable to skills shortage in the

organisation for new products/process or due to skill staff turnover. The actual skill pool has been reduced from its nominal value (Fig. 7.4a), while the training completion rate and skills in process have experienced 5% overshoot to its nominal values at $T_i = 1$ week (Fig. 7.4b). Decreasing value of T_i reduces the maximum skill pool deficit and reduces the offset value of recover. For $T_i < 2$ there are some oscillation but the peak values still under the nominal value of actual skill level. As $T_i > 6$ the actual skill pool deficit increases correspondingly. There is no recovery for skill pool with this design.

As shown in Figure 7.4b, increasing T_i values will damp the training completion rate overshoot but it will take longer for the organisation to recover the skill gap. At $T_i \leq 6$ weeks the system response with the training completion rate overshoot which is manifested in over staffing or over training for a period of time. The organisation would recover the skill loss at the values of $6 \leq T_i \leq 8$ without overshoot. For $T_i > 8$ the organisation would never recover. This is due to the extra damping introduced by increasing the skills in process feedback gain.

As shown in Figure 7.4c T_i has the similar impact to that of training completion rate on the skills in process. But at the large value of overshoot may imply training programme problem in terms of, large training lead-time and consequently excess skill level. Also an increased of settling time may give some indication of some problem at the organisation training programme and the inefficiencies in that programme.

Figure 7.5 concentrates on the effect of T_a of the actual skill level, training completion rate and skill in process responses. Figure 7.5a shows that for the best T_a values, the organisation would recover only up to 80% of the nominal value of actual skill level. At value of $T_a \leq 1$ there is initial skill pool drop at the 80% of the nominal value. By increasing $T_a > 1$, the initial skill pool drop increases and so is the settling time for recovery. Also there is no skill pool overshoot at any value of T_a . This gives the indication that either improve the organisations training recruitment efforts or to increase the level of skill pool (staff members).

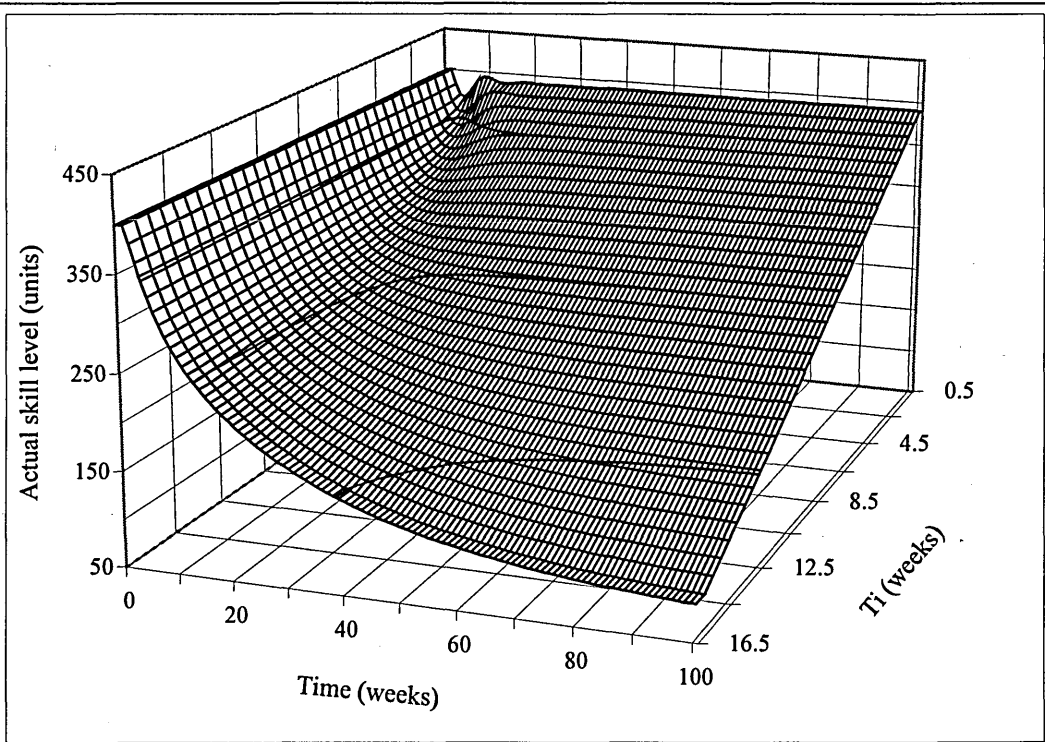

(a) Skill level behaviour ($T_p = T_a = T_w = 4$ weeks)

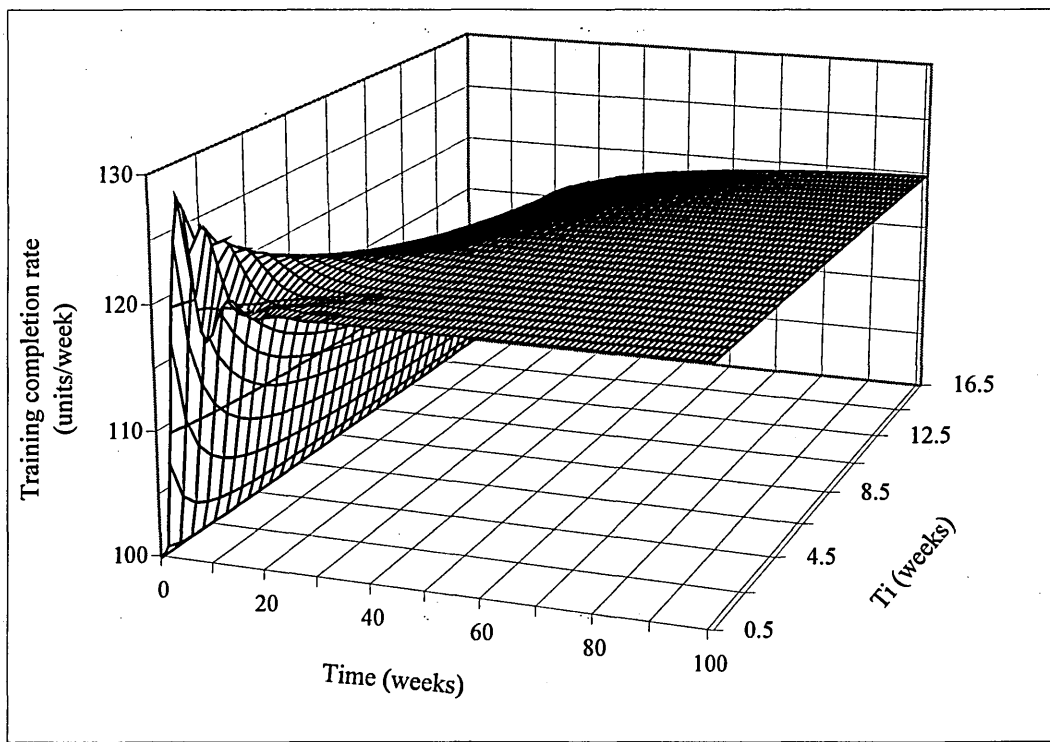

(b) Training completion rate behaviour ($T_p = T_a = T_w = 4$ weeks)

Figure 7.4: Step response of PSKPM for varying values of T_i .

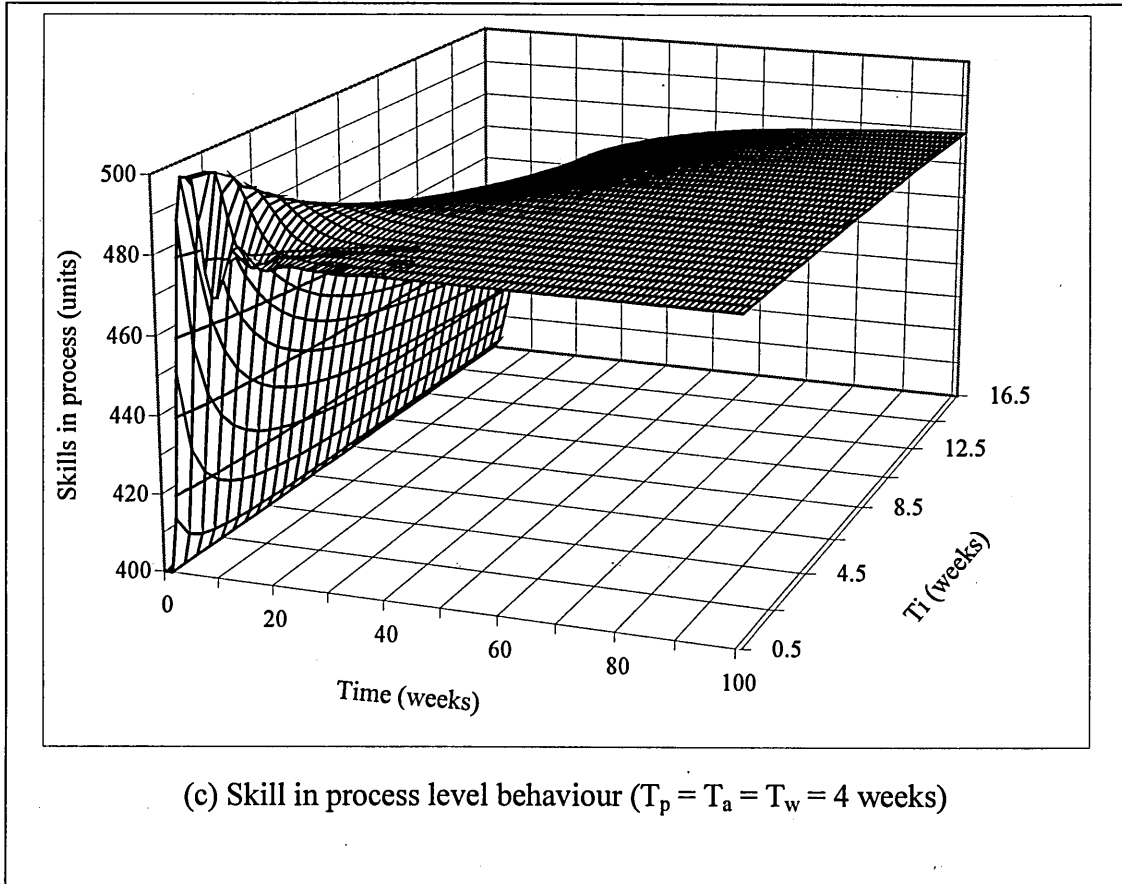
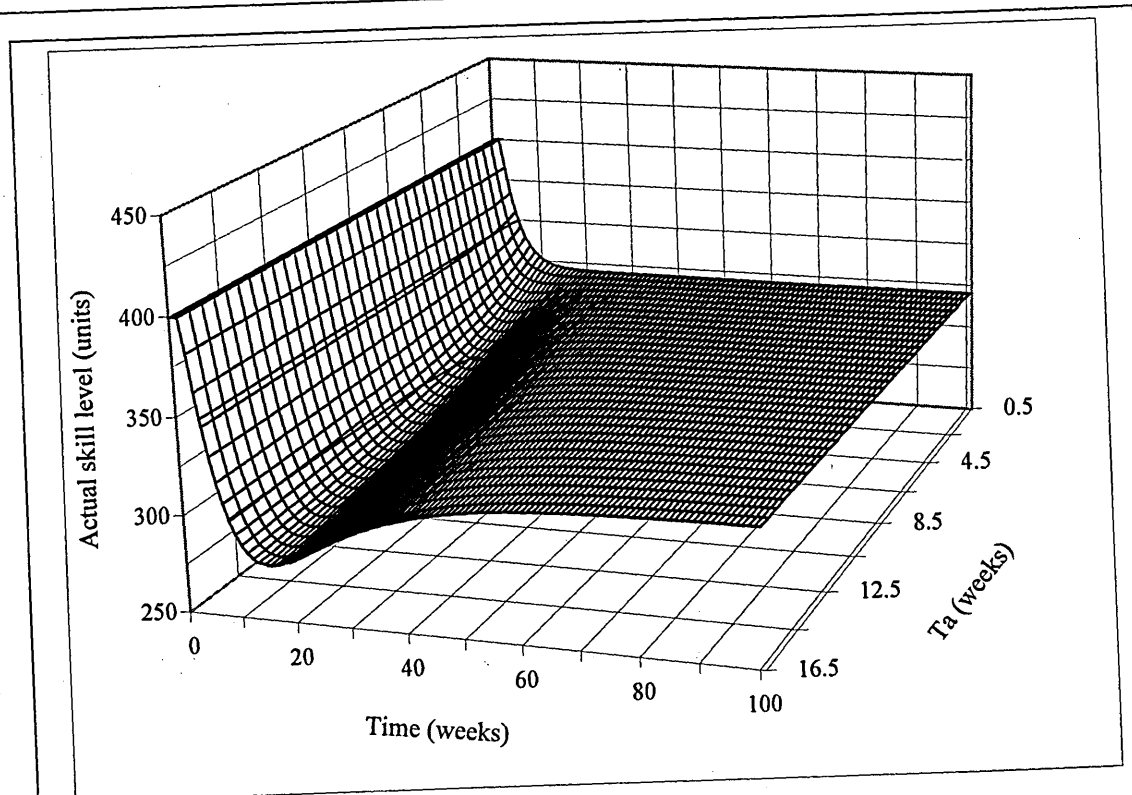

Figure 7.4: Continued

Figure 7.5b shows that for all values of T_a the maximum training completion rate overshoot is 1.35% of the nominal value, and there is no peak overshoot. The maximum rise time is 30 weeks at value $T_a = 0.5$, that decrease by increasing T_a . This means that the organisation needs at least 30 weeks to hit the steady training completion rate. Comparing the Figures 7.5b and 7.5c show that T_a has the similar impact to that of training completion rate on the skills in process. Decreasing T_a has a similar effect to T_i , but is less pronounced as shown in Figure 7.5. T_a will reduce the skill pool freefall considerably less than reducing T_i . T_a also has the advantage over T_i in that the offset value is less.

Figure 7.6 shows the skills level, training completion rate, and skills in process at different values of skill pipeline control parameter T_w . The aim is to observe how the system recovers to step input changes. Figure 7.6a indicate that as T_w decreases the actual skill level overshoot damps down although there is a corresponding increase in settling time. Specifically at $T_w < 1$ the actual skill level fall even below then the negative value after 30 weeks. This is due to the extra damping introduced by increasing the skills in process feedback gain. But at high T_w values the actual skill level gap diminishes within 20 weeks. Also at value of $T_w < 8$ organisation would never have the needed skill level. Generally, the actual skill level responses show that for the cases when $T_w \neq \infty$, there is a final value steady state offset. Figure 7.6a also shows that as T_w decrease from ∞ this final value offset increase, as does the peak skill pool deficit. Therefore, with the PSKPM the skill pool deficit is never recovered and there is the associated risk of skills obsolescence.



(a): Skill level behaviour ($T_p = T_i = T_w = 4$ weeks)

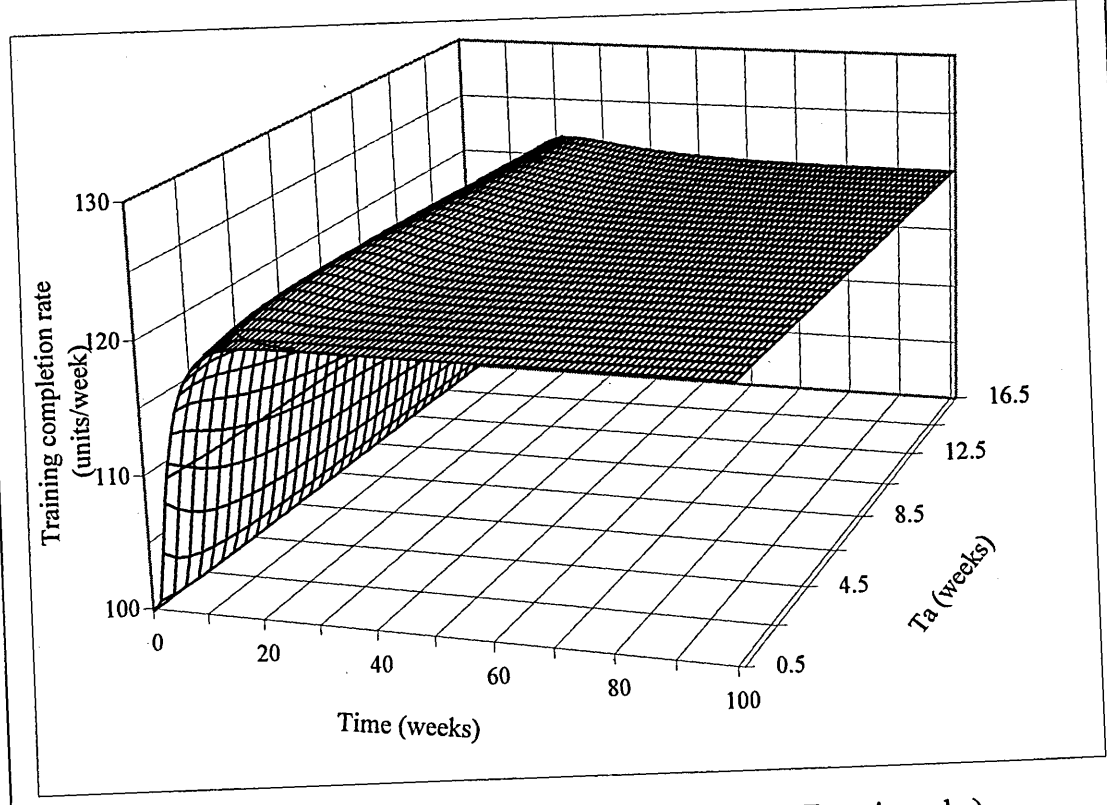

(b): Training completion rate behaviour ($T_p = T_i = T_w = 4$ weeks)

Figure 7.5: Step response of PSKPM for varying values of T_a .

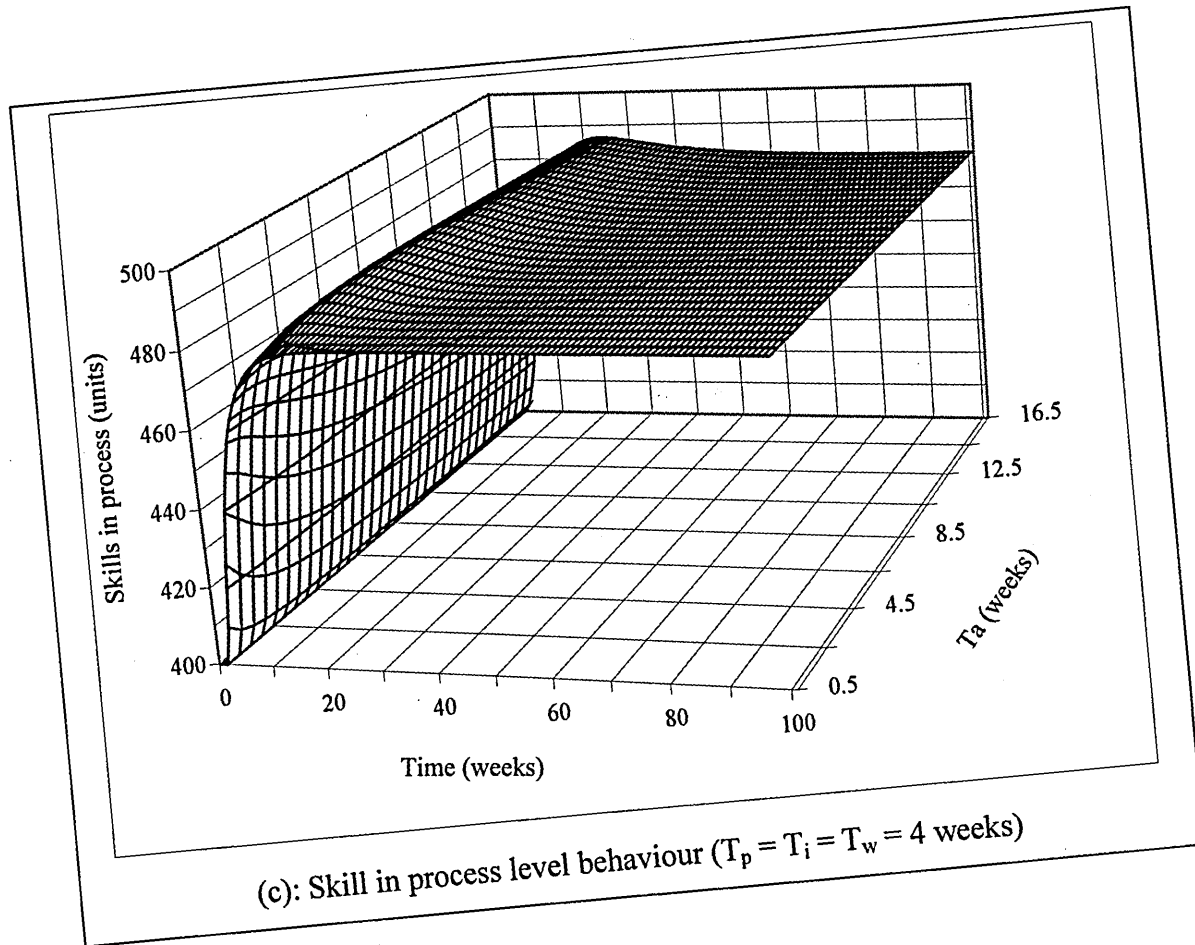
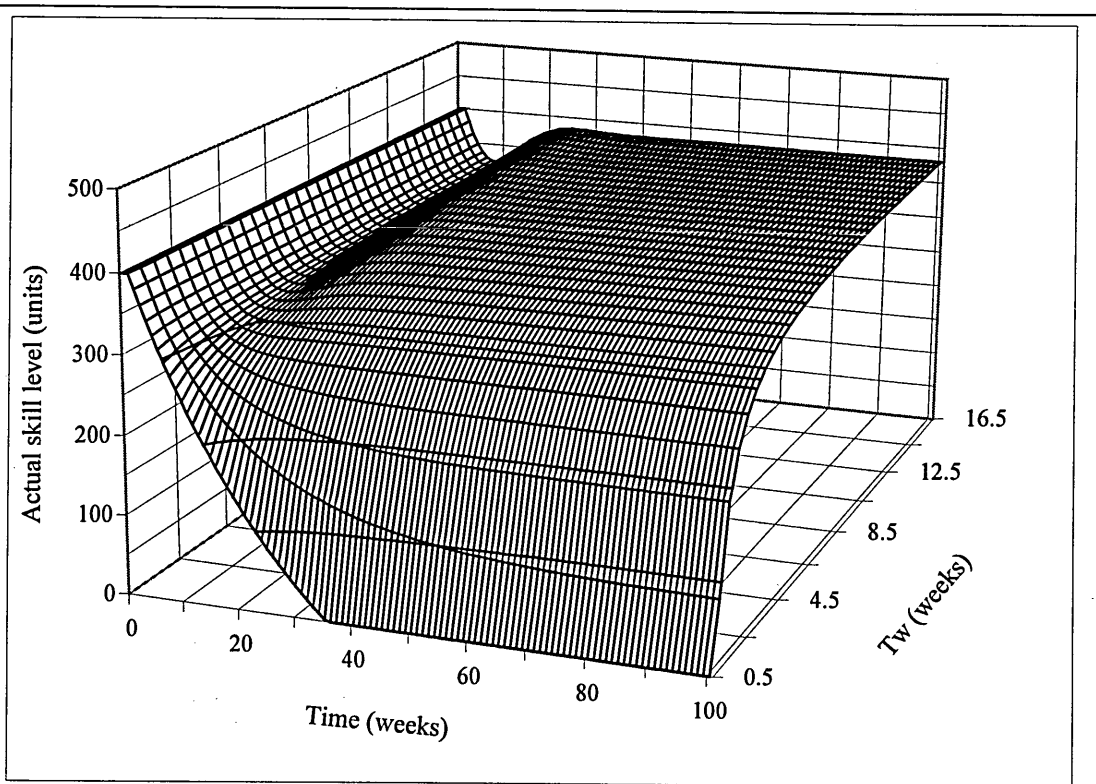
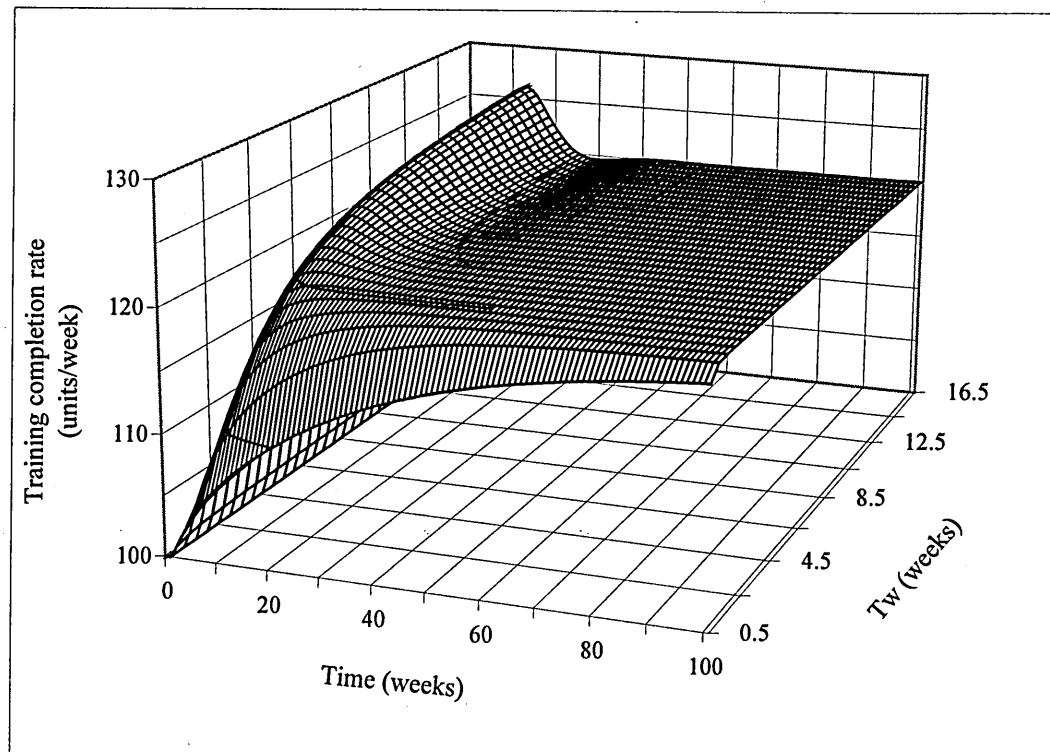

Figure 7.5: Continued



(a): Skill level behaviour ($T_p = T_a = T_i = 4$ weeks)



(b): Training completion rate behaviour ($T_p = T_a = T_i = 4$ weeks)

Figure 7.6: Step response of PSKPM for varying values of T_w .

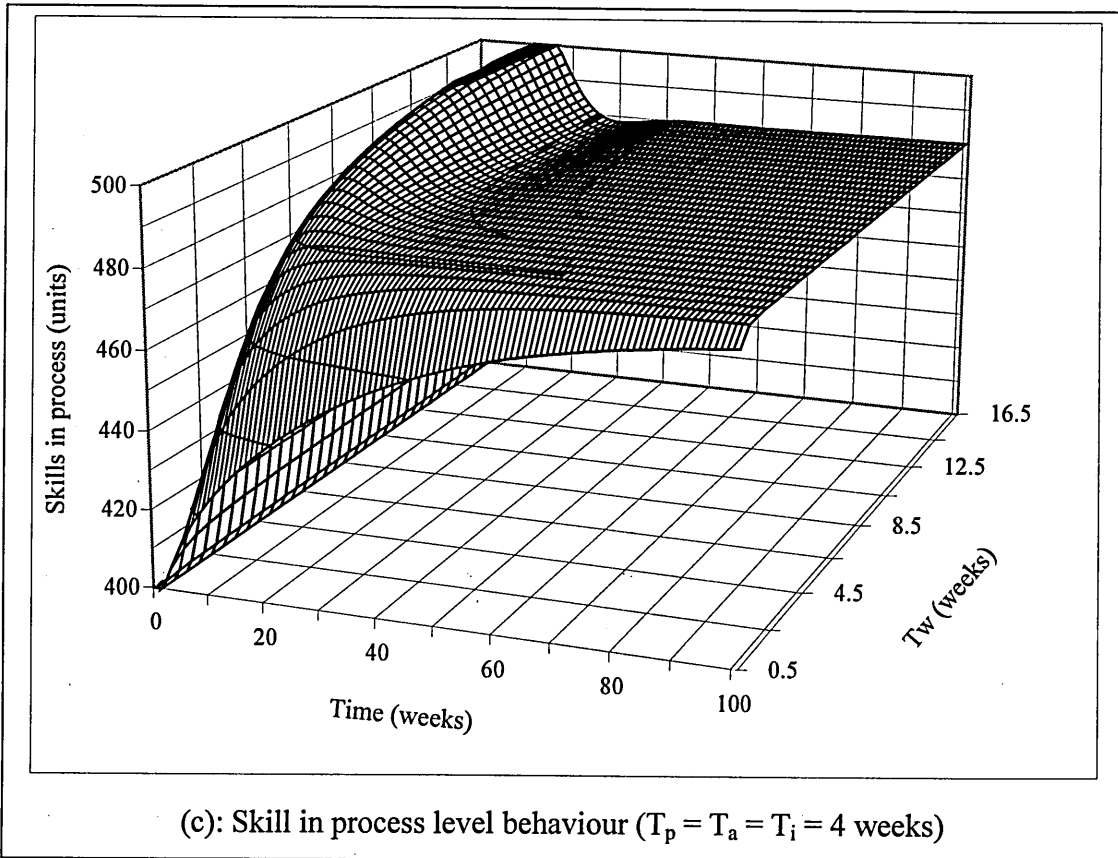
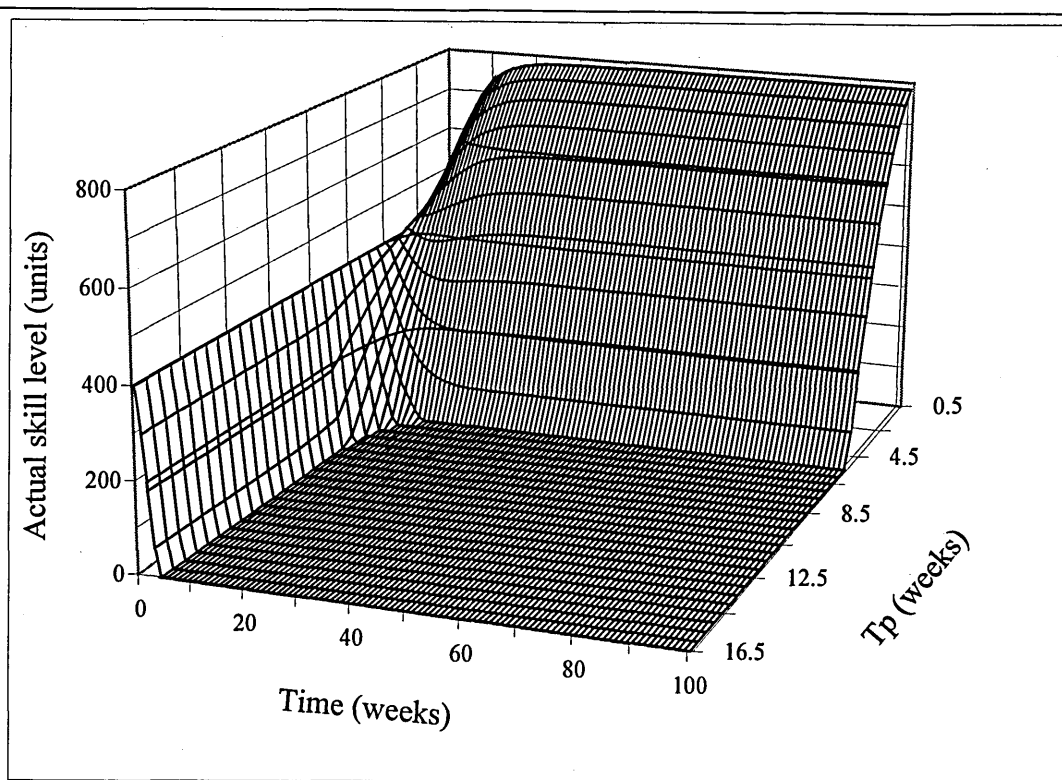

Figure 7.6: Continued.

The training completion rate responses Fig. 7.6b show that with $T_w = \infty$ (as this is the response of SKPM), the response is quite good however has an overshoot. As T_w decreases, the dynamic recovery to the input improves as both the magnitude of the peak overshoot and the corresponding settling time decreases. Also for the value of $T_w < 4$ there is no overshoot but the rise time is relatively high and approximately equal to two years. But at the value of $T_w > 8$ the system has more overshoot values and the lower setting time which the manager can hit the steady training completion rate in 35 weeks. This is due to the additional damping introduced by the extra feedback term (John, 1994). Figure 7.6c shows the skill in process responses. As shown the responses are similar to that of training completion rate. The overshoot again decrease as T_w decrease from infinity which is the original SKPM case.

Figure 7.7 illustrates the responses of actual skill level, training completion rate and the skill in process at different values of the training lead-time T_p . Comparing Figures 7.4, 7.5, 7.6 and 7.7 the responses shown at Figure 7.7 are drastically different. As shown in Figure 7.7a the actual skill level approaches zero and cross over the negative values at $T_p > 5$ weeks. At $4 \geq T_p \geq 5$ values of the actual skill level are around the nominal value. But at T_p less than the value of four weeks the actual skill level is more than the nominal values that means the organisation has an abundance of skills or redundant skills.

Figure 7.7b shows that at $T_p = 4$ weeks the training completion rate equal 100 units/week initially which is equal to the initial values of the present skill loss before applying the step increase unit/week. At the values of $T_p < 4$ the training completion rate starts with overshoot values, which increases for decreasing T_p . But at $T_p > 5$; there is no overshoot for the training completion rate. Also the initial response values decrease by increasing T_p and equals zero at $T_p = 9$ weeks. This slow recovery trend deteriorates for increasing values of T_p . The best response is at the values of $4 \geq T_p \geq 5$ for the training completion rate. At such values the rise time to recover the skill loss equals 12 weeks. As well as the maximum overshoot equals to 1% of the nominal value for a duration of 38 weeks.



(a): Skill level behaviour ($T_w = T_a = T_i = 4$ weeks)

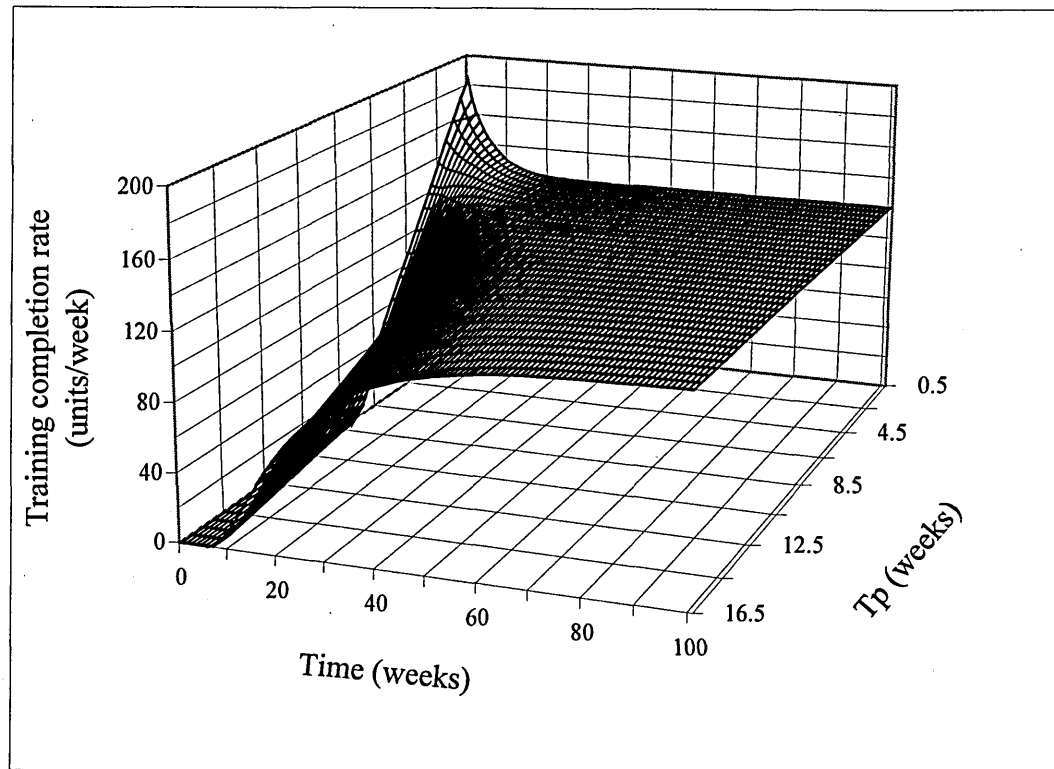

(b): Training completion rate behaviour ($T_w = T_a = T_i = 4$ weeks)

Figure 7.7: Step response of PSKPM for varying values of T_p .

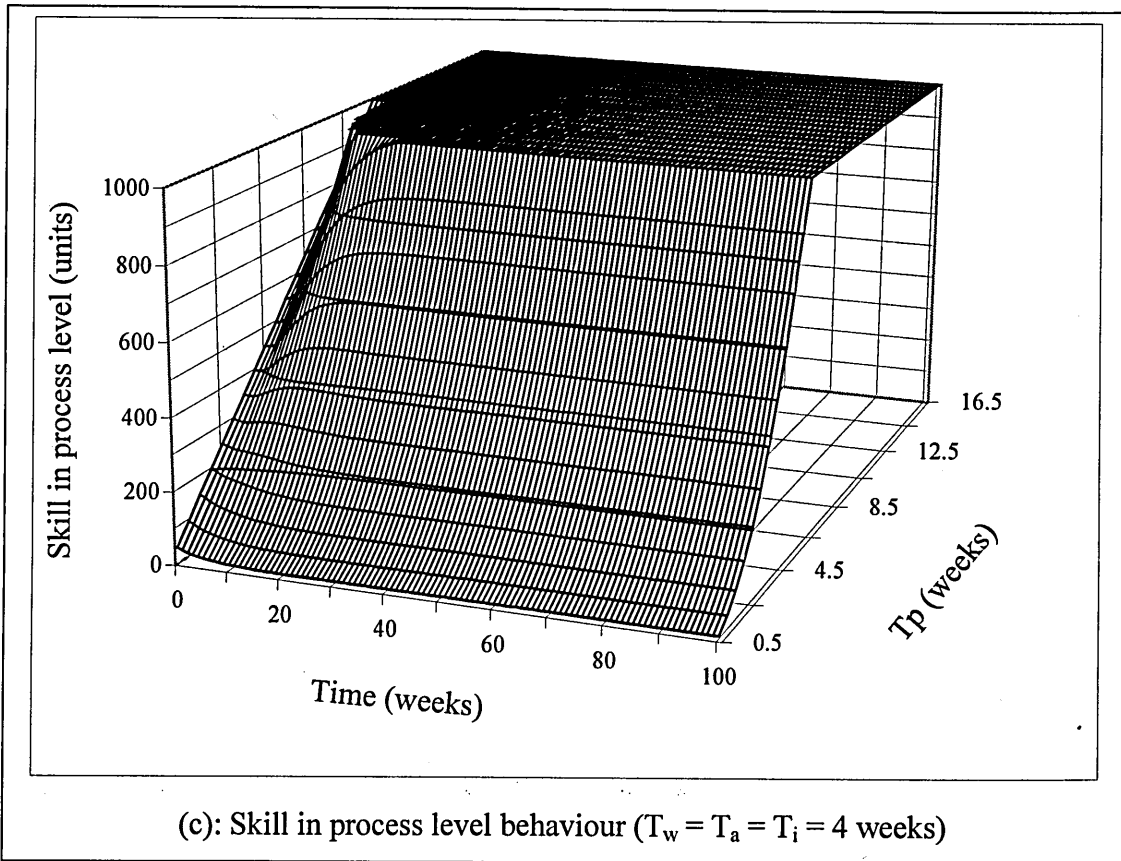

Figure 7.7: Continued.

Figure 7.7c shows the variation of T_p on the skill in process level. T_p has not the same impact to that of training completion rate. For increasing values of T_p , skill in process overshoots increase. At $T_p \leq 3$ weeks there is no overshoot however the skill in process doesn't recover and the rise time has excessive values. Also at $T_p \geq 3$ weeks the duration of skill in process overshoot is too large and never regain its nominal value.

7.2.5 Summary

The analysis, as indicted above, shows that there is a final value offset of skill pool level in the opposite direction to the change of the present skill loss. Training completion rate eventually equals to the present loss rate. While the skills in process level reaches a steady state value proportional to the training lead-time. The main problem with the PSKPM structure is that an undesirable permanent deficit results in actual skill level for a step change in skill loss rate for all values of T_w except $T_w = \infty$.

7.3 The Automated Pipeline Skill Pool Model (APSKPM)

This skill pool offset is addressed in an Automated Pipeline Skill Pool Model (APSKPM) by incorporating an extra feed-forward path where the desired level of skills in process is calculated as justified by current organisation demand. The skill recruitment rule takes into account any excesses or shortfalls in skills in process. On the basis that no skill pool offset is the desired behaviour to meet the organisation skill requirement level, the following sections consider the APSKPM structure.

The model in Figure 7.8 is a time-varying extension of the baseline SKPM. It is adapted from the simplified Work In progress (WIP) feedback and an automated PIOBPCS model (APIOBPCS) as detailed in (John *et al.*, 1994 and Cheema, 1994). The model shows that the desired value of skill in process is controlled by the adjustment time (T_w).

The influence diagram as illustrated in Figure 7.8 incorporates an experiment to eliminate some of the fluctuations. This policy experiment is set up to take into account the skills in process when defining the skill recruitment rate. The desired skill in process equals the product of the forecast skill loss rate and the T_c . The discrepancy between the desired and actual skill in process was then divided by the recruit skill delay T_w and

used as an additional component of the recruitment skill rate equation. Such a policy is generally referred to as proportional plus pipeline control.

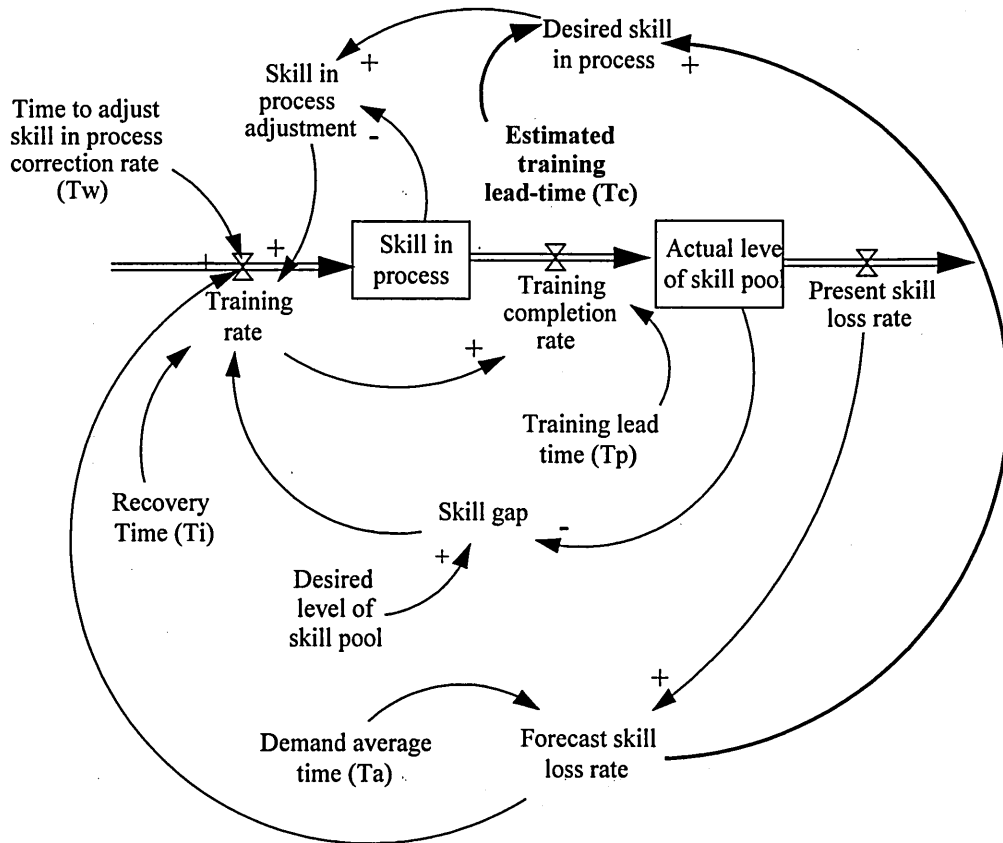

Figure 7.8: Influence diagram of APSKPM

7.3.1 APSKPM block diagram

Figure 7.9 shows a generalised form of the APSKPM model that incorporates skill in processes feedback. The terminology and nomenclature used relates to the baseline SKPM model (Chapter 6).

The structure and methodology of the design of APSKPM are derived as functions of the present skill loss rate, actual skill and skill in process levels. The skill gap is the difference between a constant desired level of skill pool and the actual skill level. The error is covered over a period specified by the proportional controller ($1/T_i$). The skill in process adjustment is the difference between the desired skill in process of the forecast skill loss rate multiplied by a gain of T_c (the theoretical value of training lead time) and the current skill in process level. The skill in process adjustment is covered over a period specified by the proportional controller ($1/T_w$).

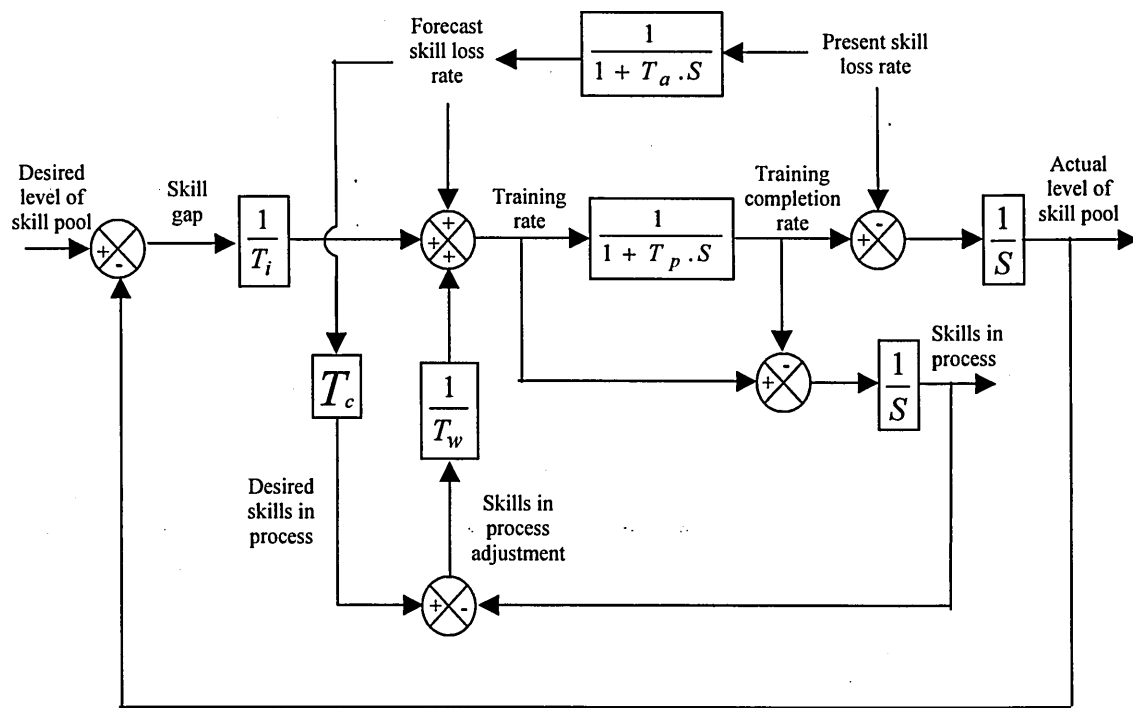

Figure 7.9: A block diagram representation of APSKPM.

The forecast skill loss rate is a function of the present loss rate where the forecast is based on exponential smoothing (this is shown as an equivalent of a first order delay with time constant equal to T_a). The organisation-training programme is controlled by the feedback from the skill in process and the actual skill level control loops as well as the smoothed forecast skill loss rate. The organisation training delay time is also based on exponential smoothing equivalent to a first order delay with time constant T_p . The organisation training programme completion rate is a function of the initial/start training programme and the training time delay. The actual skill level pool is the accumulation of the difference of the training completion and the present skill loss levels.

7.3.2 Transfer function of APSKPM

The aim of the simulation studies is to examine the effect that skill in process feedback has on the dynamic performance of APSKPM. It investigates the influence of the design parameter T_i , T_a , T_w and T_c on the dynamic behaviour of skill level, training completion rate, and skill in process. Prior to undertaking simulation studies of these controllers the transfer functions of interest are developed (the details are illustrated in Appendix 7.4).

The transfer function models of the APSKPM are: -

$$\frac{ALSKP}{PSKLR} = -T_i \left[\frac{\left(\frac{T_p - T_c}{T_w} + \left(T_a + T_p + \frac{T_a T_p}{T_w} \right) \cdot S + T_a T_p S^2 \right)}{\left(1 + T_a S \right) \left(1 + \left(1 + \frac{T_p}{T_w} \right) \cdot T_i S + T_p T_i S^2 \right)} \right] \quad (7.4)$$

$$\frac{TCRATE}{PSKLR} = \frac{1 + \left(T_a + T_i + \frac{T_c T_i}{T_w} \right) \cdot S}{\left(1 + T_a S \right) \left(1 + \left(1 + \frac{T_p}{T_w} \right) \cdot T_i S + T_p T_i S^2 \right)} \quad (7.5)$$

$$\frac{SKIP}{PSKLR} = T_p \left[\frac{1 + \left(T_a + T_i + \frac{T_i T_c}{T_w} \right) \cdot S}{\left(1 + T_a S \right) \left(1 + \left(1 + \frac{T_p}{T_w} \right) \cdot T_i S + T_p T_i S^2 \right)} \right] \quad (7.6)$$

7.3.3 APSKPM performance indices

In the case of the APSKPM, the measurement criteria are defined in similar terms to that of PSKPM, which are illustrated at section 7.1.3. These criteria highlight the actual skill level, training completion rate, and skills in process. Nine performance criteria have been chosen to describe the simulation of the model. Those are adopted from Edghill (1990) where these were used in the analysis of production control systems.

7.3.4 Dynamic behaviour analysis

The response to a step change in present skill loss rate is of importance as it is an input that is easily visualised (the responses of which are also easily interpreted) and determines the basic dynamic characteristics of the system (Coyle, 1977; Edghill, 1990). The basis of the simulation is the block diagram as shown in Figure 7.9. The simulation is implemented using *ithink* simulation package, and the simulation equations are given in Appendix 7.5.

The APSKPM is subjected to 20% drop in present skill loss rate from an initial steady state rate of 100 units of skills. The system behaviour to this step change for the three

controllers named as actual skill level, training completion rate, and skills in process for APSKPM are investigated. The design parameters T_p , T_i , T_a , T_w and T_c have been varied between 0.5 and 16 weeks. In the case of APSKPM, although the additional feed-forward term, T_c has the effect of increasing the response time, it is counteracted and the response in fact is dominated by the damping of T_c . Also for APSKPM actual skill level recovers fully to its desired level. In general the addition of skills in process feedback leads to added system stability. The skills in process error are recovered over a period specified by the proportional controller ($1/T_w$).

Figure 7.10 shows the dynamic response to a 20% step increase in the present skill loss rate for actual skill level, training completion rate and skills in process by changing the value of T_i . Figure 7.10a shows that the step increase in the present skill loss causes an initial deficit whilst skill losses are met from the existing skill level. The response then shows a moderate overshoot before settling to its steady state value. This is due to initial skill loss being met from actual skill level pool whilst extra staff is being recruited on the training programme, or new skilled staff is recruited. An obvious way to eliminate this problem is to hold extra numbers of the qualified staff or to conduct more frequent training sessions but this has the detrimental affect on the total costs. Also training is dependant on the individual capacity of acquiring these skills to become an expert or competent. Also, increasing T_i will increase the duration of the skill pool deficit. This duration gives an indication of speed of recovery from a skill pool deficit. This is calculated by looking at the time it takes for the actual skill level to return to its initial value after the skill pool drop. As T_i increases the peak skill pool overshoot reduces as well. This pool is an illustration of how well the inventory control laws are behaving. A large skill pool will manifest itself as less skill level or turnover. But this has to be balanced against a net skill pool deficit and would present difficulties with meeting the organisation requirement.

Figure 7.10b illustrates that a step change in training completion rate shows an overshoot before settling to a steady state value. Increasing T_i will reduce the peak overshoot as shown in Figure 7.10b. A peak overshoot will only occur with an under-damped system and is defined as the maximum value of the output to step change in its input. Obviously, to achieve a level of good control, large overshoots are to be avoided. A small overshoot has to be balanced against a moderate skill recovery rise time, hence a trade-off is needed.

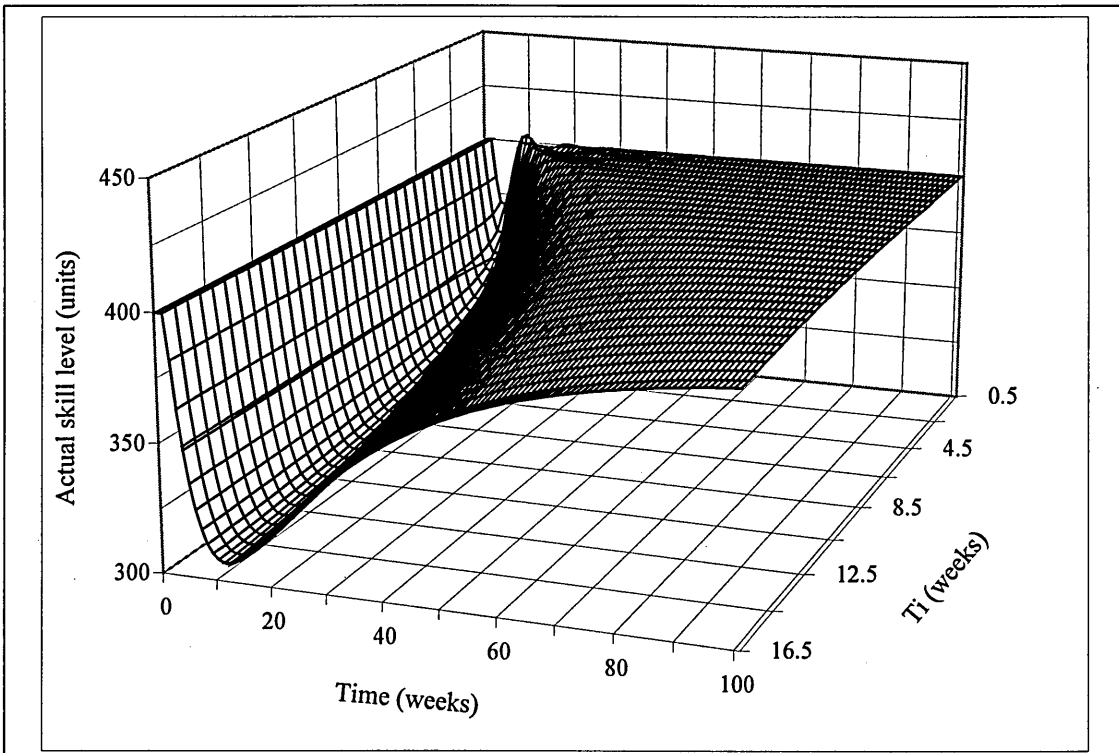

(a): Skill level behaviour ($T_p = T_a = T_w = T_c = 4$ weeks)

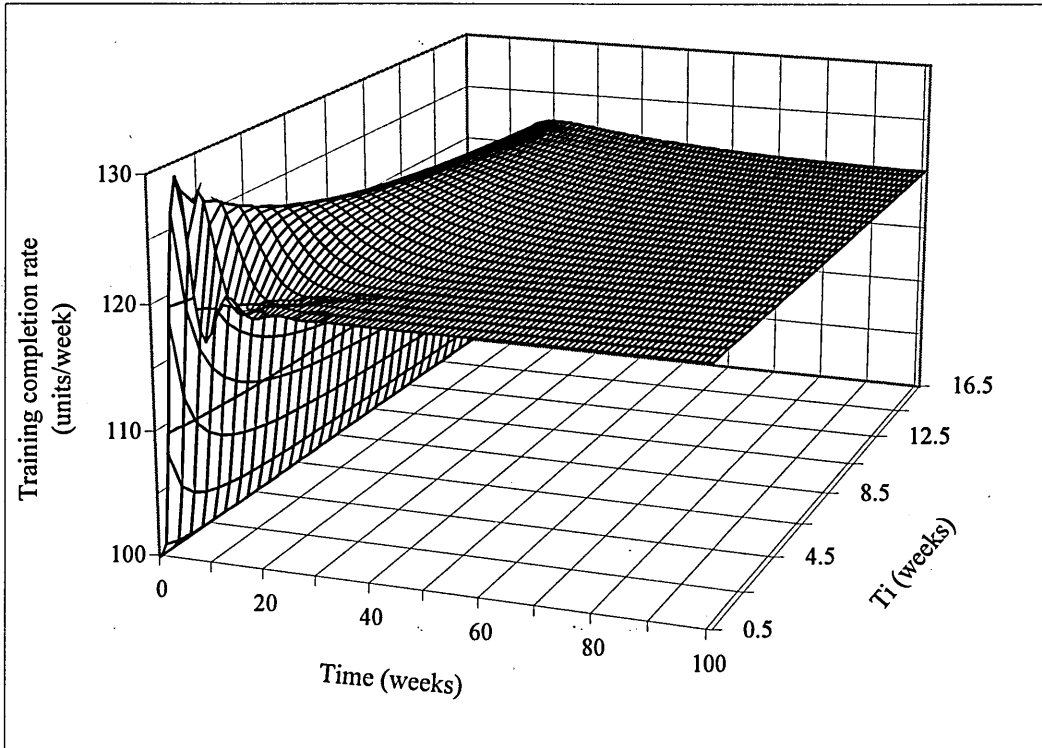

(b): Training completion rate behaviour ($T_p = T_a = T_w = T_c = 4$ weeks)

Figure 7.10: Step response of APSKPM for varying values of T_i .

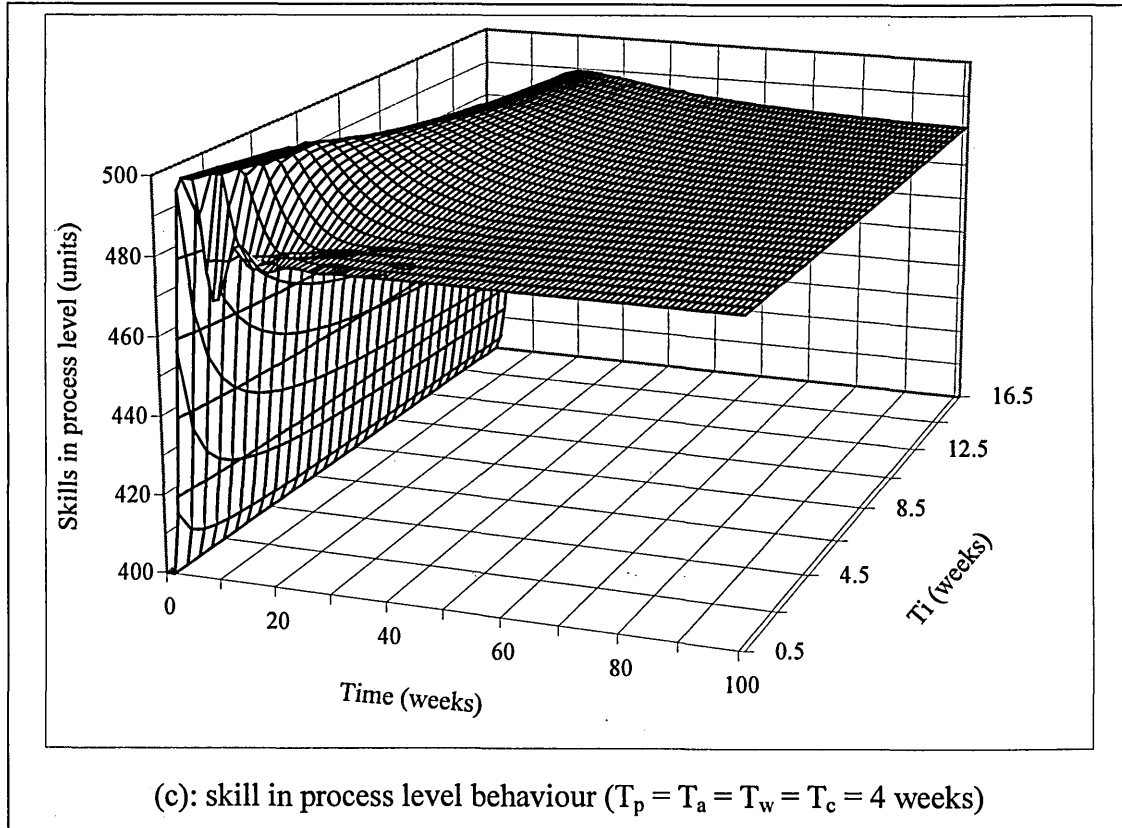
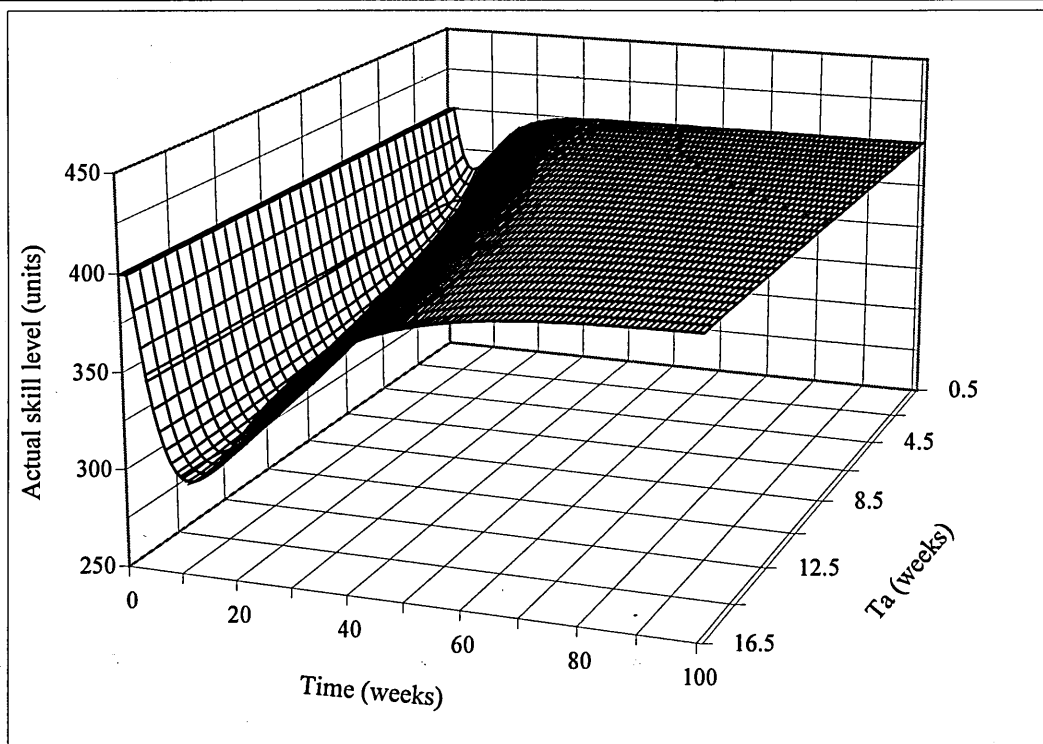

Figure 7.10: Continued.

Figure 7.10b show that increasing T_i increases the rise time. The rise time is the time taken to attain the final value of a system; (that is from 100 to 120). This rise time measurement will give the manager a useful indication of how long it will take to acquire the steady training completion rate and hence to control the frequency of training sessions. Skill in process is one of the important controllers in the training delay of uncompleted training programme. Therefore the total skill pool within the system at any point in time is the sum of actual skill level and skill in process. The training delay is also a function of the actual training lead-time. If the theoretical and actual lead-times are similar this may also imply that skill in process is being controlled, however, any deviation would show an excessively high values of skill in process. The responses for skill in process show similar properties to that of training completion rate but with the actual values multiplied by T_p as shown in Figure 7.10c.

Figure 7.11 illustrates the variation of T_a , the exponential smoothing coefficient for estimating the expected skills loss rate in the skill recruitment rate decision. The actual skill level drop and training completion rate overshoot are again evident. Also of note is the relatively narrower range of dynamic behaviour demonstrating that the feedback path design is the most influential and thus of primary importance rather than the feed-forward path in which T_a is the controlling parameter. Clearly as shown in Figure 7.11a the large value of T_a gives a slow actual skill level recovery. For decreasing T_a the skill level drop decreases as well as the settling time. For example, if the organisation forecast the skill loss rate of 20% of its pool over a period of 2 weeks, the actual skill level recovery would take about 30 weeks.

On the other hand, if the organisation is slow to react by averaging the skill loss over 16 weeks time the skill recovery time is 90 week. This means by changing the averaging time (T_a) from 2 to 16 week the actual skill level recovery time increases by 300%. As shown the smaller value of T_a explored in the Figure 7.11a reverse this trend, but in so doing creates an oscillatory response. That is to say, smaller values of T_a would induce instability in a real system. At all values of T_a there is no skill pool overshoot, which gives indication that the recruitment skill is always under or equal the nominal values.



(a): Skill level behaviour ($T_p = T_i = T_w = T_c = 4$ weeks)

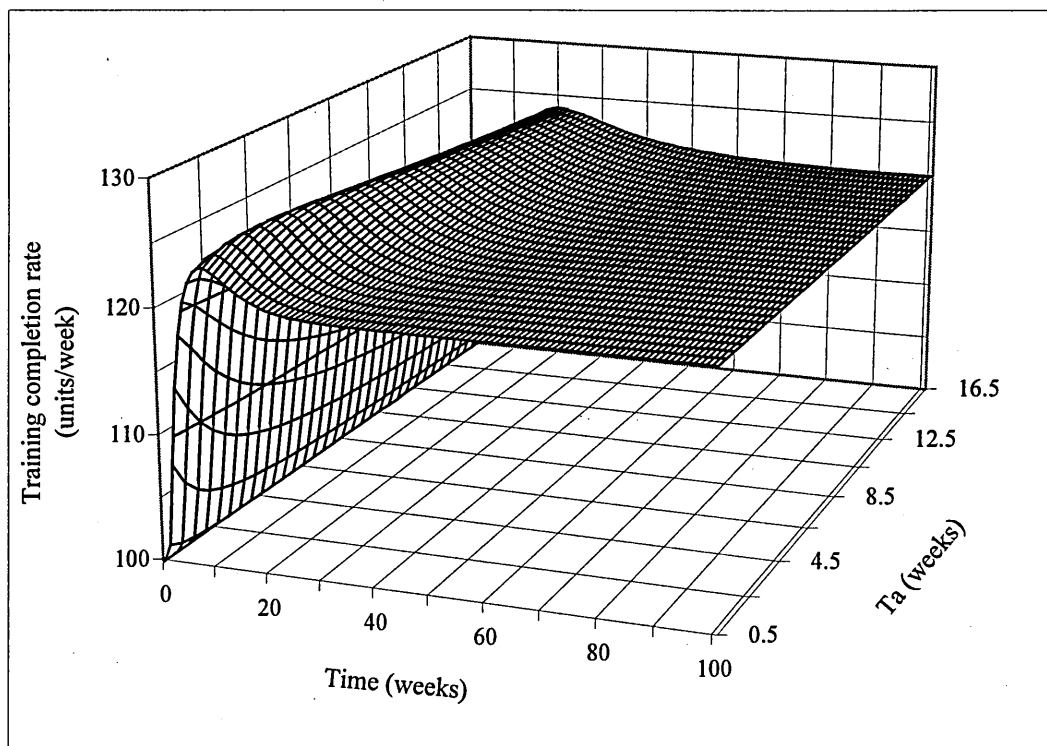

(b): Training completion rate behaviour ($T_p = T_i = T_w = T_c = 4$ weeks)

Figure 7.11: Step response of APSKPM for varying values of T_a .

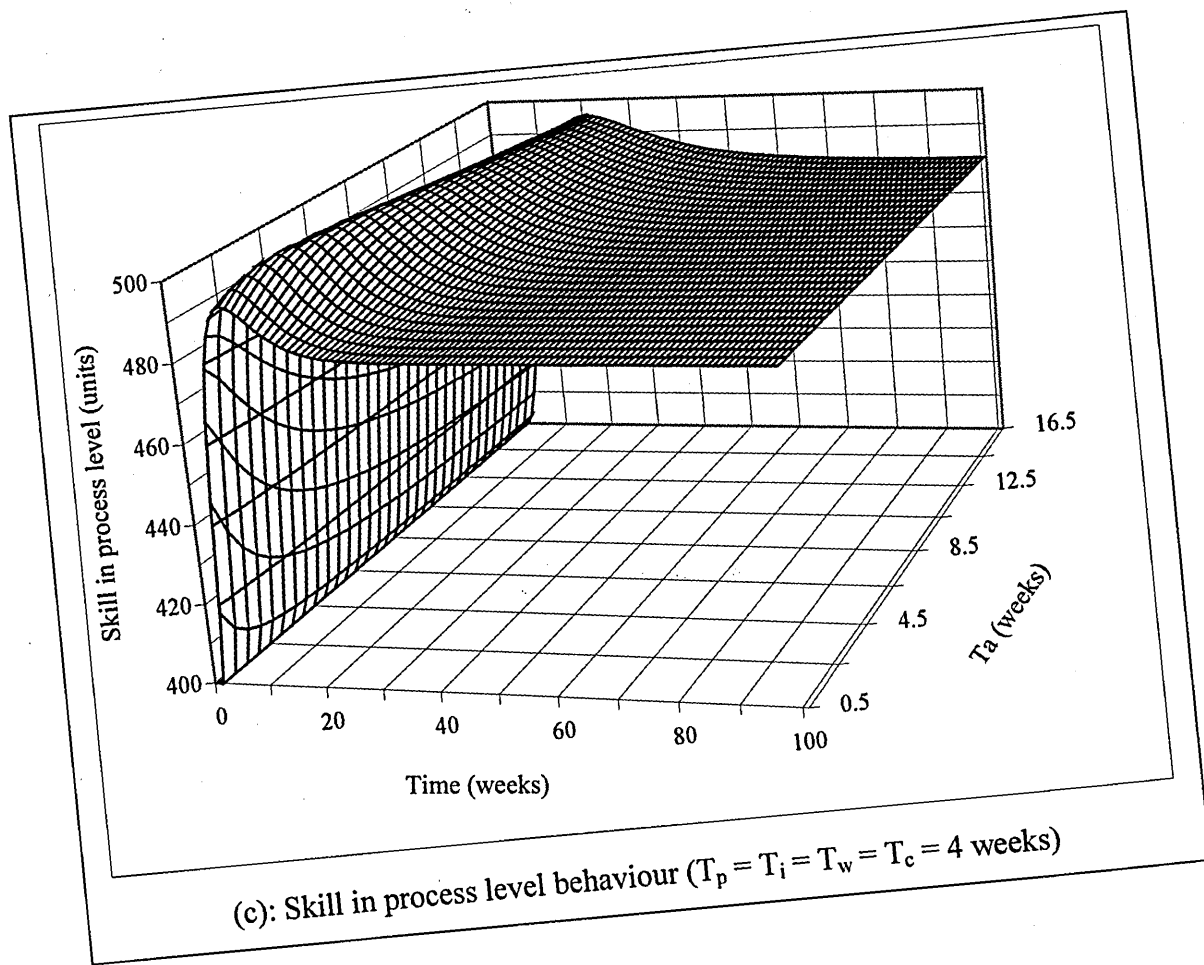

Figure 7.11: Continued.

Figure 7.11b show that the largest value of T_a gives less oscillatory response for the training completion rate. Also the changes in rise time are relatively low. For example at $T_a = 0.5$ the rise time equals 5 week and for $T_a = 16$ it equals 10 week. Also the smoothing response of the step input is not affected strongly by changing the value of T_a . At $T_a = 6$ the training completion rate peak overshoot reach the maximum value of 4.125% of its nominal value. As T_a decreases (than 6 weeks) the training completion rate overshoot increase, but the settling time decrease. However increases T_a beyond 6 weeks the overshoot decrease and the settling time increase. Figure 7.11c presents the skill in process responses, which are similar to that of training completion rate with a multiplying factor of T_p .

Figure 7.12 illustrates the behaviour of the three controllers namely, the actual skill level pool, training completion rate and skill in process at varying T_w . As shown in Figure 7.12a for T_w less than 4 weeks there is no overshoot. For $T_w > 4$ weeks the actual skill level overshoot increases. Also the actual skill level recovers fully to its desired level.

The actual skill level responses indicate that as T_w decreases, the overshoot is damped down although there is a corresponding increase in settling time. At the same time the initial skill pool deficit increase slightly for smaller values of T_w . Also as T_w decreases from infinity the peak skill pool deficit increases but the dynamic recovery does improve showing a very small deficit.

For the training completion rate, with $T_w = \infty$ the response is SKPM. As shown in Figure 7.12b as T_w decrease (from infinity) the training completion rate overshoot decrease in magnitude. However the time it takes the system to reach its steady state value slightly increases. The additional feed-forward term T_c has the effect of counteracting the damping introduced by the extra feedback term. This shows there is still enough damping present to improve the dynamic performance as T_w decreases. The training completion rate responses show that as T_w decrease, the dynamic recovery to the input improves as both the magnitude of the peak overshoot and the settling time correspondingly decrease.

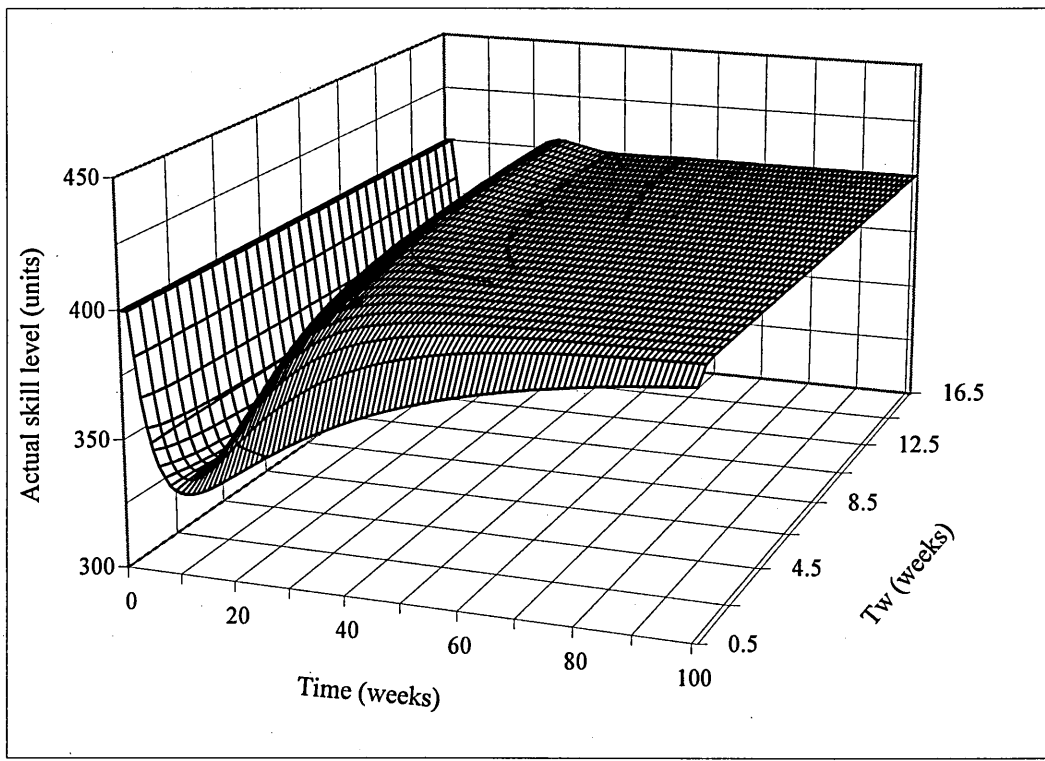

(a): Skill level behaviour ($T_p = T_a = T_i = T_c = 4$ weeks)

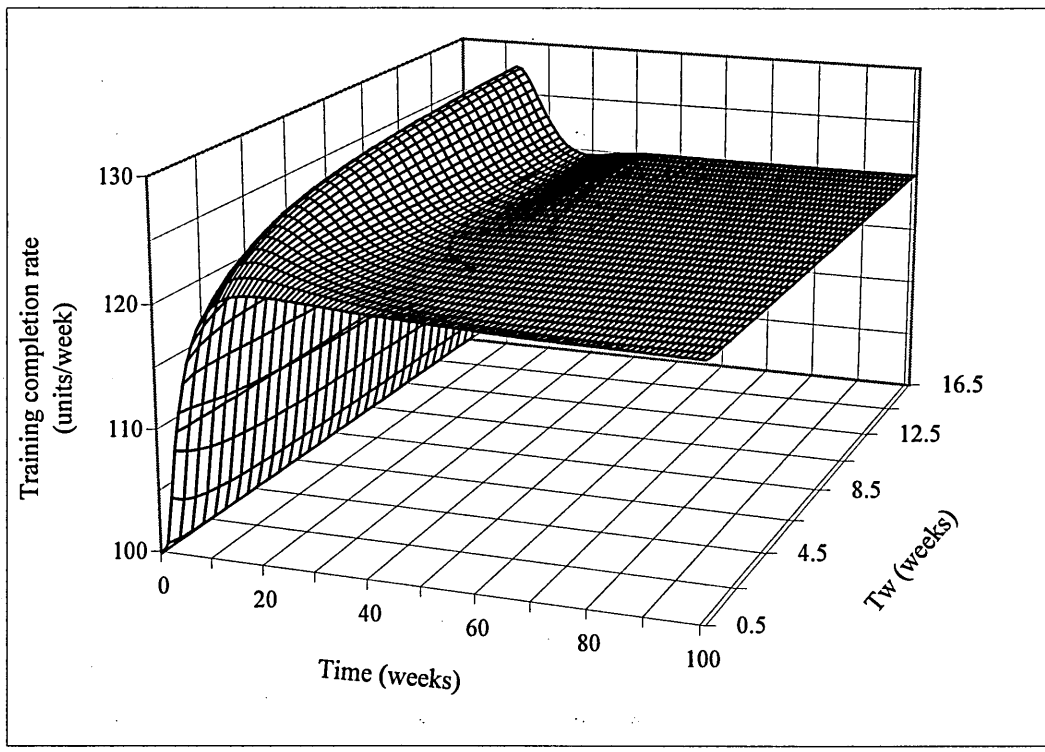

(b): Training completion rate behaviour ($T_p = T_a = T_i = T_c = 4$ weeks)

Figure 7.12: Step response of APSKPM for varying values of T_w .

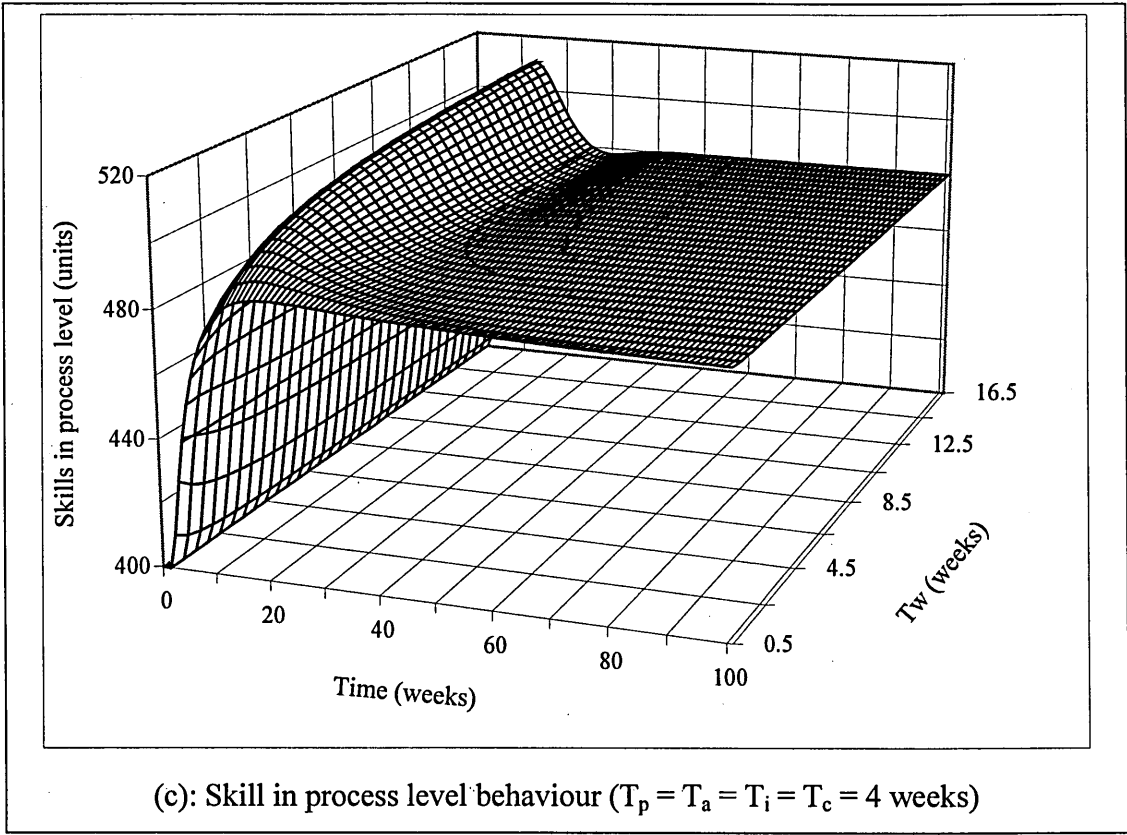
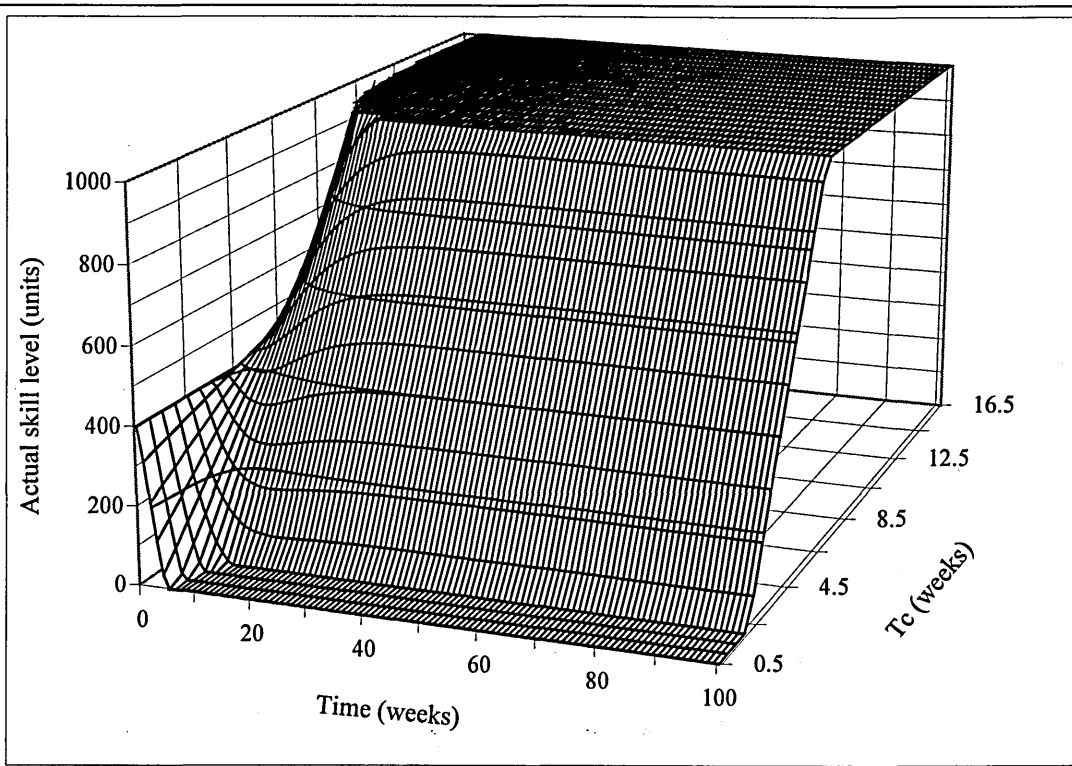
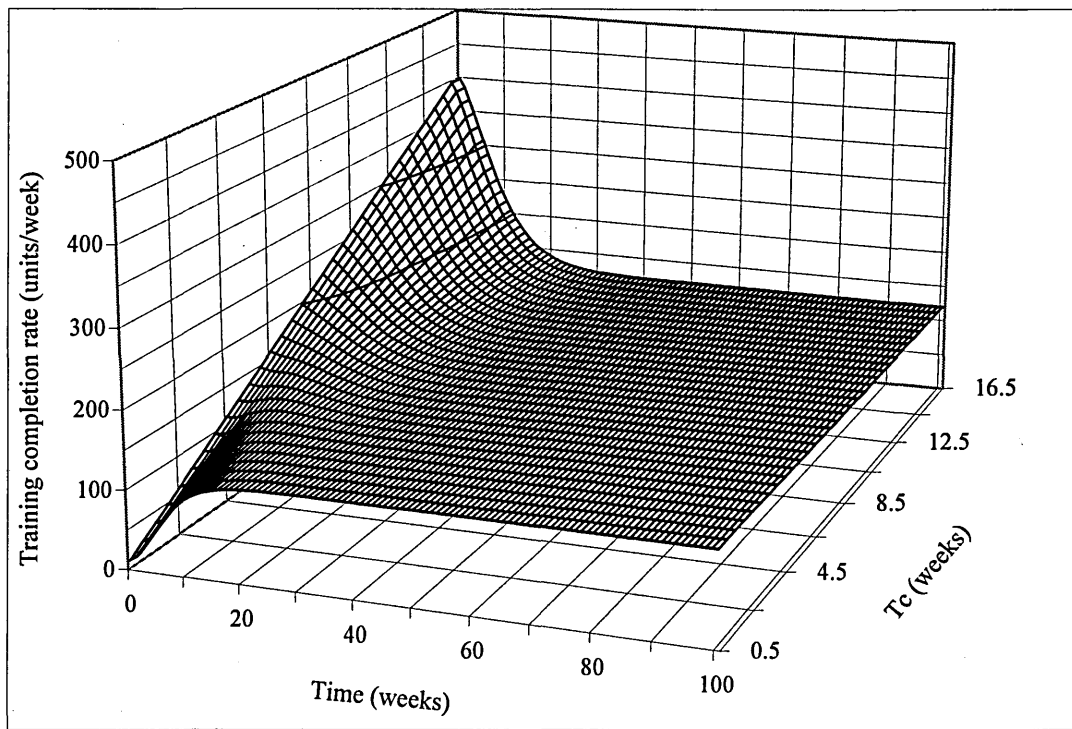

Figure 7.12: Continued.



(a): Skill level behaviour ($T_p = T_a = T_w = T_i = 4$ weeks)



(b): Training completion rate behaviour ($T_p = T_a = T_w = T_i = 4$ weeks)

Figure 7.13: Step response of APSKPM for varying values of T_c .

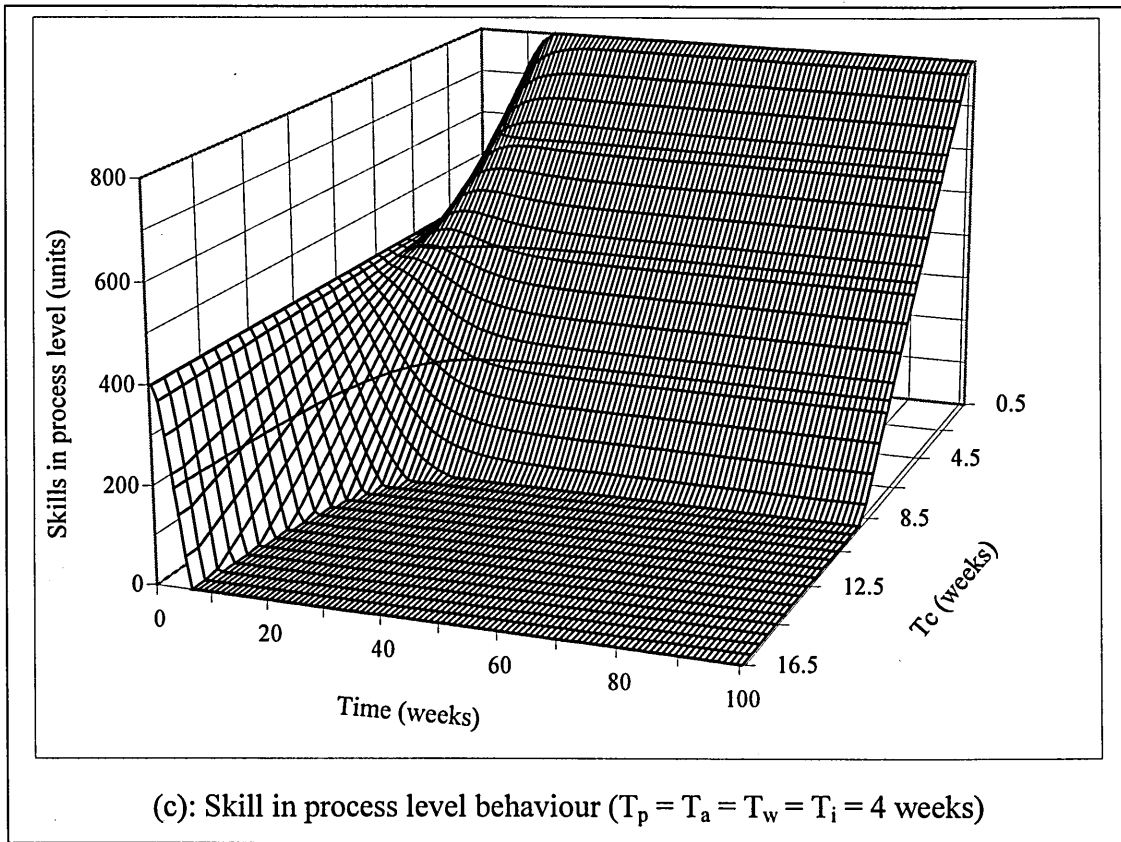

Figure 7.13: Continued

The skill in process response is similar to that of training completion rate but with a multiplying factor of T_p as shown in Figure 7.12c. The peak overshoot decrease as T_w decrease from infinity. For the APSKPM structure Figure 7.13 illustrates the influence of the parameter T_c on the same three controllers as indicated above. This parameter is used to estimate the training lead-time to control the desired skills in process.

Figure 7.13a shows that at $T_c \leq 2$ weeks the actual skill level pool drop below negative values, (skill backlog). The actual skill pool level has satisfactory behaviour for T_c between 2 and 4 weeks. At T_c equals 4 week, the actual skill level initial drop and the duration of the skill deficit are small and there is no overshoot. For $T_c > 4$ weeks the actual skill level pool constantly increase and it doesn't get to steady state value. These are unrealistic values showing organisations needs a huge space and budget to continually undertake recruitment and training resulting in excessive or redundant skills.

As mentioned earlier the simulation analysis shows the dynamic response to 20% skill loss. The training completion rate initial is set to 100 units. As shown in Figure 7.13b the training completion rate graph shows values for $T_c = 4$ week up wards. At $T_c < 4$ week the starting value is less than 100 units. Clearly for all T_c values, the training completion rate is completely recovered to the nominal value as shown in Figure 7.13b.

Figure 7.13c shows the skill in process responses for different values of T_c . There is no overshoot at $T_c = 4$ week. For $T_c > 4$ weeks the skill in process level drop extenuates and skill pool never recovers, (i.e. the duration of skill in process drop equal infinity). As T_c decrease less than 4 weeks, the skill in process level overshoot increase permanently.

Distinctive in the response of T_c parameter is an unacceptable drop or rise in the actual skill level, training completion rate, and skills in process. This indicates that T_c as a design parameter is very sensitive at certain values. The results shown in Figure 7.13 indicate that T_c should be equal 4 weeks, same as T_p .

Figure 7.14 presents the effect of T_p variation on the three controllers, actual skill level, training completion rate and skill in process. Figure 7.14a shows that at $T_p = 4$ the actual skill level behave as an optimum behaviour. At that training time the actual skill level initial drop equal to 17% of the nominal value and the settling time is 35 weeks with no overshoot. As T_p decrease below 4 weeks, the system response show a permanent

overshoot. While for $T_p > 4$ weeks, the initial skill level drop get worse and so is the recovery time, which tends to infinity. This means if the training programme takes longer than 4 weeks, the system would suffer a constant skill shortage over a sustained period of time.

Figure 7.14b illustrates that the training completion rate response experience an overshoot values for T_p less than 3 weeks. The settling time to control the duration of overshoot is 25 weeks. As T_p increase over 4 weeks, the response is under the nominal value and it doesn't recover completely. But at value of $T_p = 4$ week the training completion rate has a good behaviour. The maximum peak overshoot at $T_p = 4$ is 4% of the nominal value and the duration of this overshoot takes 42 weeks, while the rise time is 8 weeks. So the organisation can compensate for the step change in skill loss within two months.

The skill in process behaviours is different comparing to the training completion rate for varying T_p as shown in Figure 7.14c. As T_p increase the oscillatory response increases. For $T_p < 4$ weeks, the skill in process level response is under the nominal value. For all other values greater than 4 weeks, the responses are a pronounced overshoot. Obviously at $T_p = 4$ week the skill in process has good response with the rise time equal to 8 weeks. The peak overshoot is 4.25% to its nominal value, and duration of overshoot equals 42 weeks.

From the dynamic analysis as shown in Figures 7.10, 7.11, 7.12, 7.13 and 7.14, illustrate that by making skill recruitment rate a function of the skills in process change the behaviour of the system. The actual skill level reach to steady state value with no overshoot and the recruit skill rate stabilises at the new present skill loss rate with relatively less overshoot than in Figures 7.4, 7.5, 7.6 and 7.7 (PSKPM).

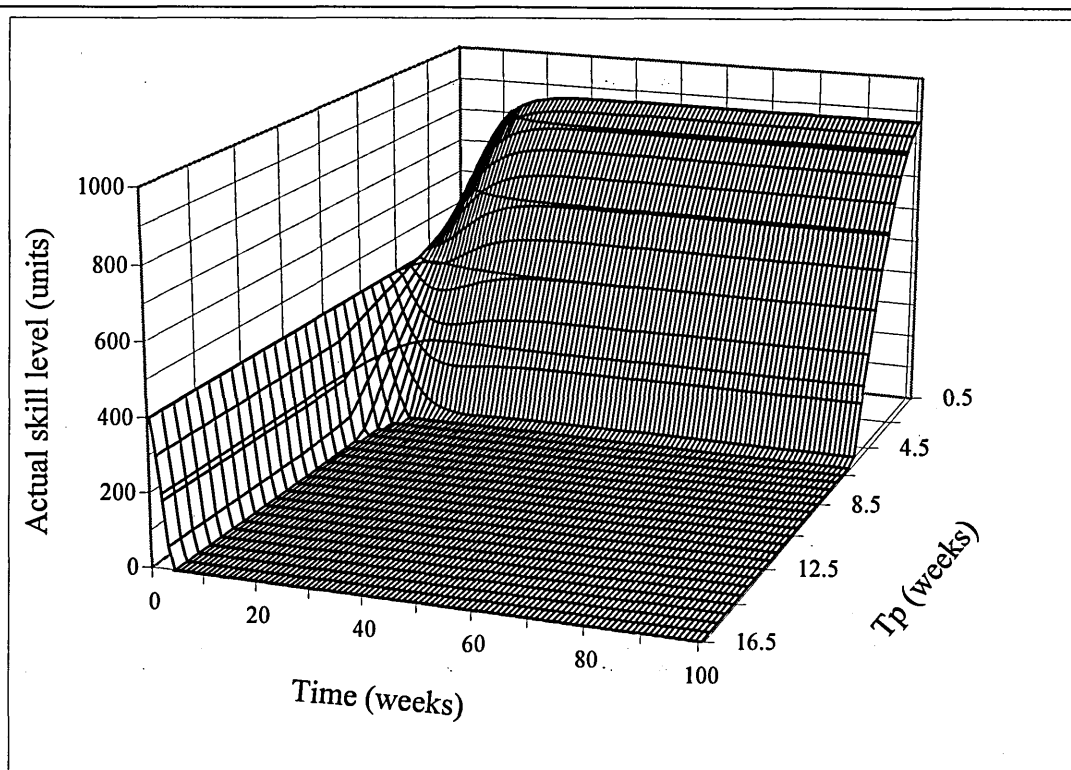

(a): Skill level behaviour ($T_c = T_a = T_w = T_i = 4$ weeks)

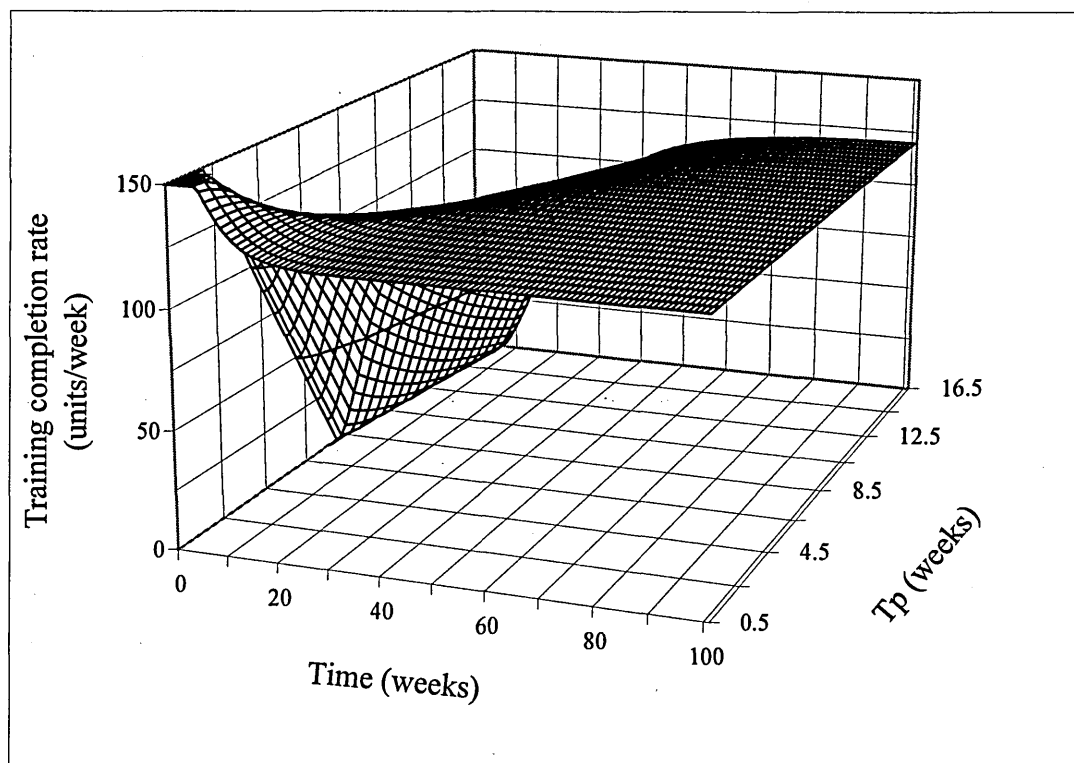

(b): Process completion rate behaviour ($T_c = T_a = T_w = T_i = 4$ weeks)

Figure 7.14: Step response of APSKPM for varying values of T_p .

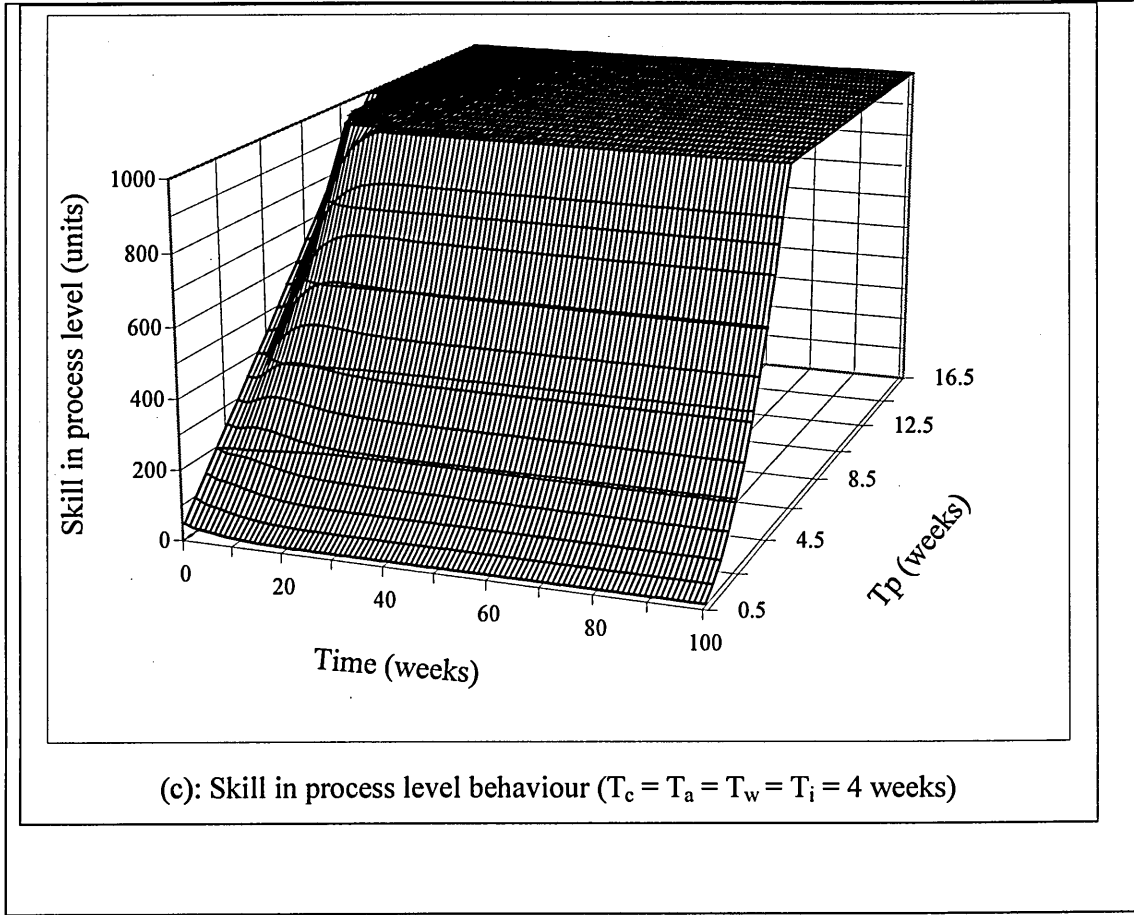

Figure 7.14: Continued

7.4 Comparison between SKPM, PSKPM and APSKPM

A comparison of the two pipeline models PSKPM and APSKPM with SKPM on the basis of the simulation results is conducted. The intention is to propose an optimum value of the time to recover the skills in process adjustment (T_w). The smoothing element (T_a) and the time to recover skill gap (T_i) are varied and good design values for these variables are obtained.

As illustrated in the previous sections the basic PSKPM model has a permanent final value offset for all values of T_w expect $T_w = \infty$. This skill pool offset difficulty is addressed in APSKPM by the extra feed-forward path where the desired level of skill in process is calculated and justified by current organisation skill level. This is compared with the actual skill in process level and adjusted to show any excesses or shortfalls. This offset is completely recovered when the gain in the feed-forward path (T_c) equals the training lead-time (T_p), the accuracy of estimating T_c is also important.

The improvement in the actual skill pool offset and its steady state recovery to a step change follows a deterioration in the training completion rate and the skill in process level. The responses show an increase in overshoot for the APSKPM for all values of T_w , however smaller the overshoot, larger the T_w .

In summary, the addition of the extra feed-forward path containing T_c improves the final value pool offset difficulty noted in PSKPM but consequently increasing the training completion rate and skill in process overshoot. APSKPM is the preferred model due to its ability to overcome the skill pool offset without making the training completion rate and skill in process level much worse.

John *et al.* (1994) have shown that $T_a = 2T_p$ and $T_i = T_p$ appear to be satisfactory designs as fluctuations are removed and the system recovers well. They determined the optimum setting for the design parameters as $T_i = T_c = T_p$ and $T_a = T_w = 2T_p$. SKPM is the same as the APSKPM without the skill in process feedback loop. The SKPM optimum was stated as $T_i = T_p$ and $T_a = 2T_p$ (Towill, 1982). Now T_a stays the same, and is not altered by the addition of the skill in process loop. T_i would naturally decrease slightly as it now has the help of T_w to reduce the rise time. This comparison is illustrated in Figure 7.15, showing the response of the three controllers for the actual

skill level, training completion rate and skill in process level at the optimum design values.

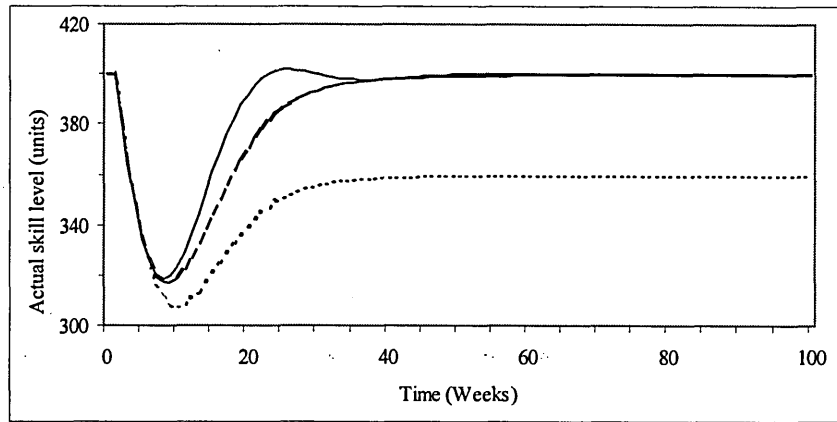

(a): Skill level behaviour

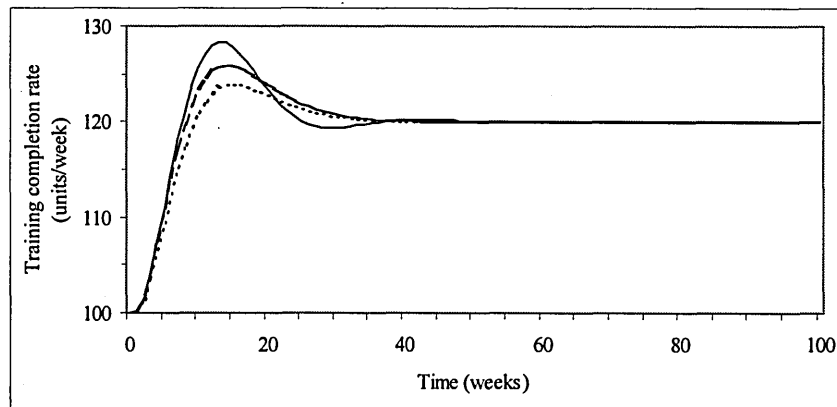

(b): Process completion rate behaviour

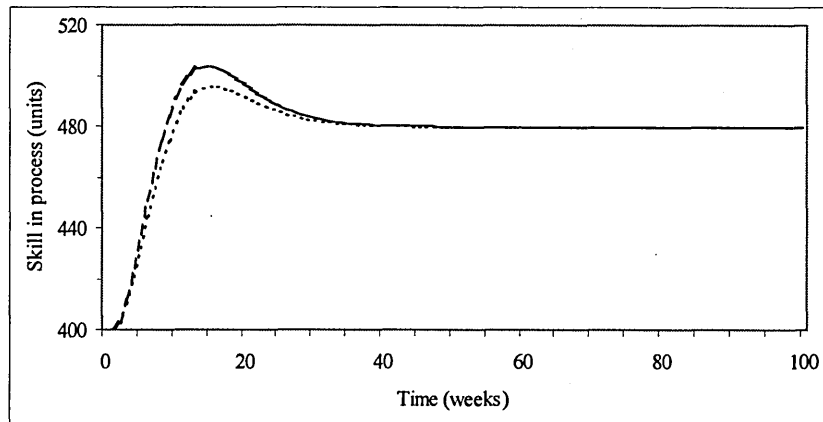

(c): Skill in process level behaviour

Figure 7.15: Step response of SKPM, PSKPM, and APSKPM at the optimum design values ($T_i = T_c = T_p$ and $T_a = T_w = 2T_p$)

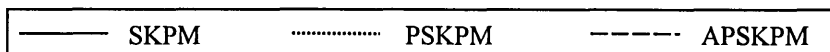

It is evident that the robustness of the algorithm to training programmes variation is improved by the inclusion of skill in process information. Also the effect of varying the training lead-time is investigated. As shown in Figure 7.14, the selective/optimum value of $T_p = 4$ week. For all other T_p values, there are permanent skill pool deficit and overshoot. Whereas at the optimum values of T_p the skill pool is completely recovered, but with an increase in overshoot in training completion rate and skill in process. The skill pool offset that occurs can only be corrected by accurate estimations of the lead-time. The value of training lead-time (T_p) should be selected by the human resource development manager. The skill in process loop also improves the filtering characteristics of the algorithm. This is because this loop forces the training rate to be closer to the forecast skill loss rate, i.e. it is counteracting the effect of the skill pool signal. However, it was shown earlier that the skill in process loop moderately increases the settling time. Table 7.1 summarise the effect of the optimum design parameter and corresponding performance indices.

7.5 Summary

The analysis of the system dynamics models developed above illustrate that Human Resource managers should use the identified design optimum parameter to develop training and recruitment policies. The skill gap can be identified by auditing the organisation's existing skills and devising training for basic learning activities and the management of the independent learning process. These skills are essential to sustain a competitive advantage and must be persistently developed over time.

The flow of appropriate skills has to be deployed rapidly to compensate the organisation changes. The rapid deployment would concern the speed at which an organisation can build, and acquired new skills. The skill development process needs to be carefully managed. In particular, it is vital to match the speed of skill development to the degree of change in organisation.

Long-term skill planning should be an important feature of a learning organisation. The culture of organisational learning allows for the systematic storage of information for future decision-making by others in the organisation or in other words embedding the knowledge. Possession of such skill can make the difference between success and failure (Nigel, 1997).

The next Chapter concludes this thesis by presenting discussion of conclusions, contribution to knowledge and recommendations.

Performance index at the optimum design parameters ($T_i = T_c = T_p$ and $T_a = T_w = 2T_p$)		Skill pool models		
		SKPM	PSKPM	ASKPM
Skill level measurements	Initial skill inventory drop (Percentage from the desired value)	20.37%	23.1%	20.65%
	Duration of the skill inventory deficit (Week)	22	∞	40
	Peak skill inventory overshoot (Percentage from the nominal value)	0.46%	0%	0%
Training completion rate measurement	Rise time (Week)	8	10	8
	Peak overshoot (Percentage from the nominal value)	6.94%	3.3%	4.99%
	Duration of overshoot (Week)	17	30	30
Skill in process measurements	Rise time (Week)	N/A	10	9
	Peak overshoot (Percentage from the nominal value)	N/A	3.29%	4.99%
	Duration of overshoot (Week)	N/A	60	64

Table 7.1: Summary the effect of the optimum design parameters and corresponding performance indices.

7.6 Reference

- Coyle, R., (1977), "Management System Dynamics", Chichester, John Wiley & Sons
- Cheema, P., Towill, D. R., and Bishop, B., (1989), "A combined feed-forward/feed-back 'to-make' model for a multi-product machine shop", Proceedings of the 5th National Conference on Production Research, Huddersfield Polytechnic, UK, PP. 101 – 105.
- Cheema, P., (1994), "Dynamic analysis of an inventory and production control system with an adaptive lead-time estimator", PhD Dissertation, UWCC, University of Wales College, Cardiff

- Edghill, J. S., (1990), "The application of aggregate industrial dynamics techniques to manufacturing systems", Ph.D. Thesis, University of Wales College of Cardiff, Cardiff, Wales
- Hafeez K., Bhip B., Towill D., (1994), "systems design of an adaptive to make model", DTI technology's conference, London 1994.
- Horowitz, I. M., (1963), "Synthesis of feedback systems", Academic Press, New York, NY
- John, S., Naim M., and Towill D., (1994), "Dynamic analysis of a WIP compensated decision support system", International Journal of Manufacturing System Design, Vol. 1, No. 4, PP 283-297.
- Nigel Petts, (1997), "Building growth on core competences - a practical approach", Long Range Planning, Vol. 30, No.4, PP.551-561.
- Parnaby, J., (1979), "Concept of a manufacturing system", International Journal of Production Research, 17(2), pp 123-135
- Sterman, J. D., (1989), "Modelling managerial behaviour: Misperceptions of feedback in a dynamic decision-making experiment", Management Science, 35(3), 321-339.
- Towill D. R., (1981), "Coefficient plane models for control systems analysis and design", Research studies press, New York, NY, pp. 178-83.
- Towill D. R., (1982), "Dynamic analysis of an inventory and order based production control system", INT. J. PROD. RES., Vol. 20, No. 6, PP 671-687.

DISCUSSION AND CONCLUSIONS

8.1 Introduction

This study has reinforced that total quality management is a fundamental dynamic step on the path to become a learning organisation. This research developed a questionnaire designed to examine the organisation efforts (first, second, or third wave) and measure the effect of learning on the organisational performance. However, close examination of the questionnaire reveals more attention to organisational learning enabler, as well as, the organisation outcomes (organisation performance). In general, it may be too much to expect conventional questionnaire items to capture the events implicit in a learning process, even if they are administered at different points in time.

For the present author it was beneficial to combine the outcome and process approaches, thereby establishing a stronger association between actions that are construed as learning and the outcomes of learning. The research method that most commonly incorporates both process and outcome is simulation (e.g., March, 1991 and Ouksel *et al.*, 1997). However, simulations only achieve their knowledge of process because the researcher has created a mathematical model to represent it. The learning process is both described and deliberately manipulated to study the effects of alternative processes on outcomes. Obviously, simulation studies are limited in their capacity to represent events in the real world, although they have generated valuable insights in many cases.

The purpose of this Chapter is to present the discussion and conclusions, and contribution to the body of knowledge, which are significant to the fields of total quality management, learning organisation, system thinking and system dynamics. A critically assessment and recommendations for future research directions are also be made.

8.2 Discussion of conclusions for each Chapter

Chapter two provided an assessment of the meaning of quality and total quality management. A literature review was undertaken to establish whether a generic

definition of quality exists. The various definitions of TQM in the literature, rely on the hard aspects of quality (production/operations aspects, measurement and control of work.) i.e. tools and techniques, without reference to organisational design and human issues. TQM has been superimposed on existing organisational structures with minimum attention paid to wider issues of organisational structure, worker dignity, process improvement, communication, culture and organisational politics. Furthermore, two types of the quality award models, which are the Malcolm Baldrige National Quality Award (MBNQA) and the European Foundation for Quality Management (EFQM) have been presented and discussed. Chapter two concluded by identifying the gaps and weakness in TQM field and synthesising the information in the literature into a coherent framework in an attempt to portray the key principles and components of TQM.

Chapter three conducted a detailed literature review of learning and organisational learning. The difference between organisational learning and learning organisation has been presented. The literature of learning organisation has tended to focus on the learning process; many of the recipes offered by authors in this field has been concerned with the social interactions and cultural precedents which encourage the learning process within teams and between teams in organisations. Rather less attention was paid to the outcome of the learning process. These outcomes are in the form of set of skills and knowledge that are created within the organisation. More recently contributions to the debate have considered the knowing, and knowledge creating, organisation, and the field of knowledge management has encouraged the perspectives on how knowledge can be created and managed.

In the present author's view a learning organisation is an organisation skilled at creating, acquiring and transforming knowledge, and at reforming the behaviour patterns of workers and decision makers to reflect new knowledge and insights so as to evaluate total quality management in every process. Organisation failing to grasp the basic truth that TQM requires a commitment to learning is the reason that failed programme outnumbers successes, and success rates remain distressingly low. In order TQM to succeed the entire workforce must acquire new knowledge, skills and abilities.

Chapter four offered a historical account of the evolution of TQM. It has identified eighteen essential factors contributed to total quality management Table (4.1). Table (4.1) concluded by identifying the minimum and maximum ratings of these elements. The most important element is the continuous improvement (6.5). This is matched with the objectives of the TQM is the continuous improvement process. However it is highlighted in order TQM to succeed, management commitment to learning and acquiring new knowledge and skills are required. The learning cycle element scored very low (1.75) which provide some explanation why do TQM implementation success rates remain distressingly low? Also, this Chapter delivered a survey of ten most notable authors in the learning organisation field in a tabular form (Table 4.2), where various subjective weightings have been assigned identifying learning characteristics. This is to help organisations see the learning organisation elements and systems benchmarked in a compact format. Further a relationship between TQM and organisation learning has been established in the form of learning flywheel (Figure 4.2), and transformation from TQM to learning organisation has been described in a step-by-step procedure (Figure 4.3).

The main deliverable of this Chapter was the conceptual framework for the learning organisation (Figure 4.4). The conceptual framework consists of twenty-eight elements, which are again categorised under the Technologies and tools (**T**), Organisation and system (**O**), and People (**P**) dimensions. Nineteen endogenous dependent outcomes has also been identified and grouped under, non-financial and financial performance categories. Chapter four laid out framework for illustrating the link between the total quality management (first wave), dynamic system wide performance (second wave) and organisational learning (third wave). The relationships between training, skills, knowledge and competence developments are the main ingredients in the learning processes, which are equivalents to the three waves of quality. Another contribution of this Chapter was identifying and providing the relationships of non-financial measures in the context of TQM and organisational learning.

Chapter five provided the findings of a questionnaire survey, which was used to evaluate the conceptual framework for both manufacturing and non-manufacturing organisations. Through analysis of the collected data, some important research findings have been summarised and presented. In fact only four organisations were found to be in the third

wave of quality. Nine organisations were found to be in the second wave of quality. Seven of them had not yet embarked on a journey to become a learning organisation.

The overall results have shown that more than half of the respondents expect that organisational learning should benefit in terms of reduced defect rates (37%); increased customer satisfaction (47%); improved information sharing process (81%); individual competence development (68%), increased productivity (46%) and reduced order cycle time (51%). Only a few respondents did not anticipate any improvement in organisation performance, and 2 respondents thought that improved learning process would not help to speed up the innovation process for new products/services.

In the financial performance category, very little difference was noted between the first wave and the second wave organisation (37% to 44%, respectively). So in essence, second wave is more about cultivating qualitative measures and essential organisation support systems in an organisation. However, with respect to the third wave, financial as well as non-financial performances improvement has been recorded. The main difference between the second wave and the third wave organisations are the knowledge management efforts and the competence development programmes, and these organisations have experienced direct benefits of such implementation. These results are in line with the framework developed in Figure 4.4 emphasising that non-financial measures are the key difference between the first, second, and third waves of quality. Finally, Table 5.3 summarised the overall profile of the twenty-six organisation respondents.

Whilst organisations recognise the importance of creating, processing and transferring knowledge, so far they have been unable to translate this competitive need into organisational strategies. This observation was supported by the fact that only 2 respondents reported that their organisations currently were 'very efficient' at leveraging learning to improve performance. In fact altogether, 50% respondents reported that their organisations were developing dynamic system wide performance as an organisational strategy. However, only 15% of the respondents indicated that their organisations were 'extremely good' or 'very good' at generating new knowledge, using knowledge in decision-making or accessing external knowledge.

To verify these findings, each respondent was asked to indicate whether their organisation was developing an organisational learning strategy and/or if the organisation was either implementing or had developed specific continuous improvement programs. A total of nine respondents (35%) stated that their organisations were developing TQM as a base line for the organisational learning. Most of the 17 organisations (65%) were in the early stages of rolling out programmes and initiatives to support their organisation learning strategies. Of these thirteen organisations (50%) were in the second wave of quality implementing dynamic system wide performance. On the other hand only four organisations (15%), were actively introducing all of the organisational learning activities listed in the framework.

Survey results have been indicated that organisations are experiencing great difficulty in translating organisational learning theory into practice. Few organisations have effectively adopted a holistic approach to organisational learning. In fact, essential 'building blocks' for speeding the learning process in the organisation, such as, embedding new knowledge into the organisation and measuring the strategic value of competence assets, were almost completely absent or ineffectively performed in most of the surveyed organisations.

The organisations, which introduce the third wave strategies, believe that learning is taking place both at the strategic organisational level and at the level of individual worker. However, for organisations still utilising first wave techniques, no or very little learning take place within production practices or training practices. The second wave creates an atmosphere where the individual learns by acquiring specialised skills.

In conclusion, from this sample group of organisations it was seen that although most of them understand the commercial or institutional demands to introduce organisational learning as a business strategy, few benchmarks of best practice have emerged. Indeed, when considering the noted lack of learning process expertise and skills and the cited organisational barriers to create knowledge-based organisations, the substantial difficulties organisations face in this critical transformation process becomes readily apparent.

Chapter six presented causal relationships for the three learning waves. The value of system dynamics model, both theoretical and problem specific, in establishing cause-effect relationships and providing a vehicle for studying design alternatives has been highlighted. The learning process system is complex and time varying, often with counter-intuitive relationships between cause and effect. This has been shown that using the dynamic analysis techniques and computer simulation model of IOBPCS greatly improves the understanding of system behaviour. This has been lead to a better system design in terms of skill level control without excessive fluctuations in the skills recruitment. Using IOBPCS model the Skill Pool Model (SKPM) has been used as a datum for the dynamic analysis. Computer simulation was used to find the criteria values for the step input responses for a combination of parameter values for the skill models. Using an industrial dynamics simulation model of skill pool has been lead to a better system design (Human resources system in this case) in terms of skill level control without excessive fluctuations in the rate at which skills are recruited. SKPM optimum was stated as $T_i = T_p$ and $T_a = 2 T_p$ at $T_p = 4$ weeks.

The primary concern is what happens when an organisation faces fundamental change. The organisation can possibly utilise consultants to assist in the change implementation, but of equal concern is how its regular managers will be able to manage the new situation. In this case there is significant skill reduction as the new processes. To boost the necessary skill through training may not be feasible, and even if it were, there are long time lags. The other option is to acquire the necessary skills by recruiting new staff who already possesses those skills. This highlights the skill paradox, that if growth is not generating the need for new posts that can be filled by staff with the new skill then this may only be possible if the organisation has staff leaving who can be replaced (Winch, 1998).

The recruitment may be an expensive way to acquire the new skill, particularly if redundancy, early retirement or other inducement has been required to create the space for the new staff. It also assumes that the necessary new skills are readily available in the employment market place.

Chapter seven improved the dynamic behaviour of the skill-acquired model by adding an extra feedback term to SKPM. The addition of an extra feedback term to SKPM

algorithm based on expected skill in process pipeline levels improves the dynamic performance of PSKPM. However, the analysis has been shown that the main problem with the PSKPM structure was that an undesirable permanent deficit results in actual skill pool level for a step change in the present skill loss rate for all values of T_w (except $T_w = \alpha$). This skill offset has been addressed in APSKPM by adding the extra feed-forward path where the desired level of skills in process has been calculated as justified by current organisation demand. Although APSKPM reduce the risk of skill unavailability, the downside is that increased amplification is evident in training completion rate for the corresponding values of T_w .

The addition of an extra feed-forward path to PSKPM, representing the pipeline skills in process target value based on the knowledge of expected training lead-time and smoothed skill recruit rate, eliminates the actual skill level offset problem although this is based on accurate visibility of the training such that $T_c = T_p$. whilst in reducing or eliminating this offset, this however increase the overshoot for the training completion rate and skill in process level for the step input.

It was concluded that the APSKPM would be a good model for the skill recruitment and training. The optimum design parameter values are $T_i = T_c = T_p$ and $T_a = T_w = 2T_p$ for the given values of skill level and skill loss rate. It can also be concluded that this design responds well to an expected step input, and following the input signal closely for training completion rate without worsening the actual skill levels.

8.3 Contribution to the body of knowledge

The overall contributions of this work are summarised as: -

1. The characteristics of TQM and organisational learning are identified in a very clear format.
2. The conceptual relationships between TQM and organisational learning are clearly established, and the process to move from TQM to become a learning organisation is identified.
3. A structured framework is devised to link organisational learning elements with the financial and non-financial performance measures. This allows organisations to structure their strategic thinking and operational processes in line with the organisational learning elements.

4. On the basis of the framework, a questionnaire survey has been designed and implemented as a means to identify the milestones reached for an organisations on journey to become a learning organisation.
5. Introduced the system thinking tools to provide a better understanding of the causal relationships for the first, second, and third waves of quality.
6. A quantitative analysis of the fields of organisational learning, TQM and human resource management is provided on the basis of system dynamics models.

The above contributions are of particular relevance to the fields of total quality management, organisational learning and system dynamics. This is reviewed in detail in the following sections.

8.3.1 Contribution in TQM field

TQM is not just about improving production steps and reducing cycle times, however. It is a thought revolution in management (Ishikawa, 1985). In other words, TQM is about changing the mental models of management in order to enhance an organisation's fundamental capability to determine its own future. This change requires more than a one-time shift in thinking; it means continually re-evaluating the way managers think. Sustaining this thought revolution requires not only engaging in the continual improvement activities already accepted by many organisations, but also changing the conventional wisdom and mental models shared within an organisation. As Garvin (1993) states "continuous improvement requires a commitment to learning. How after all can an organisation improve without first learning something new?"

8.3.2 Contribution in organisational learning field

The outcome of the learning process is the ability to continue to learn, the set of skills and knowledge that are created within the organisation, and are accessible to those who might be in a position to use them in contributing towards the vision of the organisation. More recently contributions to the debate have considered the knowing, and knowledge creating, organisation, and the field of knowledge management has encouraged the development of perspectives on how knowledge can be created and managed as described in Chapter 3.

In this dissertation, the main building blocks of the learning organisation are identified to meet objective 1 as described in Chapter 4. Also the conceptual framework and a theory for linking total quality management to organisational learning have been developed and outlined in Chapter 4. Chapter 5 evaluates the learning organisation framework through the questionnaire survey. The dynamic simulations of the first wave learning are presented. A methodology and research process was proposed for making progression link between the first, second and third wave of quality using causal-loop tool.

A learning organisation should be an organisation skilled at creating, acquiring and transforming knowledge, and at reforming the behaviour patterns of decision makers to reflect new knowledge and insights so as to evaluate total quality management in every process. Organisations failing to grasp the basic truth that TQM requires a commitment to learning is the reason why failed programmes outnumber successes.

8.3.3 Contribution in the system thinking and system dynamics fields

It is established that the field of system dynamics, its methodology, principles, and practices, can make a significant contribution in helping to understand the dynamic complexity of organisational learning. Intuitively, managers find value in the approach because of its ability to capture complex organisational dynamics, but the methodology can be very difficult to put into practice. This research gained some important insights in attempt to translate the methodology into more digestible pieces for mass consumption.

One lesson is that causal-loop diagrams can be made easier to use by delineating a step-by-step process for constructing them. Causal thinking is at the core of organising idea. Causal-loop diagrams are to display all the major influences and feedback loops that exist between variables; they provide a qualitative representation of the feedback structure of the system as outline in Chapter 6.

The present research has proved the application of system dynamics in the field of organisational learning whose visual form supports understanding of the problems of retaining and developing the skills base as illustrated in Chapter 6 and 7. This model would apply to most kind of organisation. However, some organisations, large multi-divisional organisation in particular, may have additional means of supplementing their

skill base in times of major change. One form of enhancement is through job rotation or secondment with sister organisations, which is available as an option to the organisation; this can be called upon to quickly boost the skill base.

8.4 A critique

Many organisations for example, manufacturing, as well as private organisations delivering professional services and operating in a rapidly changing socio-economic environment are often concerned mainly with the production of any tangible outputs rather than innovation, problem-solving and learning. An innovation organisation must necessarily incorporate a strong interplay of the learning processes which regulate the creation of knowledge, skills, and its competence in the organisational context and which would constantly improve operations affecting productivity. All three learning loops, as identified in this thesis, have an information exchange with one another, in the form of three high-level feedbacks. This creates an extended interdependence between the roles played within the context of each learning loop. These relationships form the basis for the development of a formal system dynamics model, which is presented in Chapters 6 and 7.

There are however, a number of limitations in the present work: -

- No clear criteria to chose the TQM elements in Table 4.1 and use of subjective weighting against each quality Guru. This also applied to organisational learning Table 4.2.
- There is a lack of explicit inter-relationships between the learning organisation framework enablers with results.
- A small sample size to validate the framework.
- The questionnaire is based on subjective assessments.
- Crisp rules were used to distinguish between the first, second, and third wave organisations.
- The system dynamic models need validation in a “real” case scenario.

8.5 Future directions

Along with the limitations identified in section 8.3, future work could build on this study in a number of ways.

- First, field research (questionnaire survey) can be conducted to develop some explicit and quantitative relationships between learning organisation framework element and continuous improvement, continuous learning and organisation performance.
- Second, the system dynamics model developed here can be challenged and improved. This work has drawn on one model of learning loops (skills inventory model) and on supporting theory (organisational learning framework). Therefore, some alternative organisational learning theories can be studied to formulate the relationships between organisational learning and the new product development process.
- Third, the simulation model can be extended by linking the three learning waves and by including other feedback loops. There are numerous factors that affect learning organisation and organisational performance that can be represented in such a model. Factors and mechanisms affecting learning loops/processes could be studied and incorporated into the model.
- Fourth, further work is needed for a better understanding of the role of mental model in individual and organisational learning, especially the types of mental models that are appropriate for representing dynamic complexity, the methods with which to capture the understanding of such complexity, and the means through which new learning's can be transferred to the whole organisation.
- A way forward is the examining of the influence of process-oriented learning, which is based on interactions between the members of the organisation and its objectives. On the basis of the so-called holographic-learning (Morgan, 1986) learning processes would be self-organising instead of being initialised by their environment conditions, or by the management interventions. The question is what kind of effects will appear if employees gain the ability of self-recognising and self-solving problems which belong to their own reality, and which are original and new to them.

8.6 References

- Garvin, D. A., (1993), "Building a learning organisation", *Harvard Business Review*, July – August, 71, pp.78-91.
- Ishikawa K., (1985), "What is Quality Control? ", Prentice Hall.
- March, J. G., (1991), "Exploration and exploitation in organisational learning", *Organisation Science*, 2 (1), 71–87
- Morgan, G., (1986), "Images of organisation", Beverly Hills: Sage Publisher.
- Ouksel, A. M., Mihavics, K., & Chalos, P., (1997), "Accounting information systems and organisation learning: a simulation", *Accounting, Management and Information Technologies*, 7 (1), 1–19.
- Winch G., (1998), "Dynamic visioning for dynamic environments", *Journal of the Operational Research Society*, Vol. 49, pp. 354-361

APPENDIX 1.1

PUBLICATIONS STEMMING FROM PHD WORK

Publications related to PhD work: -

1. Hafeez K., Abdelmeguid H., and E. K. Lo, (1997), "Learning in virtual supply chains", 3rd Anthropocentric Lean Production Systems (ALPS) Conf. Free University, Belgium.
2. Hafeez K., Abdelmeguid H., and E. K. Lo., (1998), "Establishing a learning culture in transnational supply chains", Workshop on International Operations, Aston University, 31st March. 26
3. Hafeez K., H. Abdelmeguid, E. K. Lo and E. M. Rodriguez-Falcon, (2000), "Information Systems for Facilitating Learning in Supply Chains", The 4th World Multiconference on Systemic, Cybernetics and Informatics (SCI2000) and the 6th International Conference on Information Systems Analysis and Synthesis (ISAS2000), Orlando, USA, July 23-26.
4. Hafeez K., Abdelmeguid H., and E. K. Lo., (2000), "A framework for Organisational Learning", International Conference on Systems Thinking in Management (ICSTM), 8-10 November, Deakin University Waterfront Campus, Geelong, Victoria, Australia

Other publications: -

1. Hafeez K., E.M. Rodriguez-Falcon and H. Abdelmeguid, (2000), "Knowledge Management in Supply Chains", International Conference on Systems Thinking in Management (ICSTM), 8-10 November, Deakin University Waterfront Campus, Geelong, Victoria, Australia
2. Hafeez K., H. YB. Zhang, H. Abdelmeguid and S. Iqbal, (2000), "Firm Competence Evaluation Framework using AHP", International Conference on Systems Thinking in Management (ICSTM), 8-10 November, Deakin University Waterfront Campus, Geelong, Victoria, Australia

APPENDIX 2.1

QUALITY DEFINITIONS

Table below defines quality from the viewpoint of different quality professionals and to provide a conceptual scheme for the discussion of TQM. This can be classified in three sections: - customer-base, Service and Manufacturing-base, and Value-based definition.

1 - Customer-base definition.	
ISO 8402 (1986)	The totality of features and characteristics of a product or service that bare on its ability to satisfy a given need.
Garvin (1988)	Quality is measured by the degree to which the wants and needs of customer are satisfied.
Juran (1988)	Quality is fitness for use.
Morris (1992)	The degree of fitness for purpose or function indicating that quality is a measure of the satisfaction of customer needs.
Oakland (1993)	The core of a total quality approach is to identify and meet the requirements of both internal and external customer

2 - Service and Manufacturing-base definition.	
Crosby (1979)	Quality means conformance to requirements.
Garvin (1988)	Quality refers to the amount of desired attributes contained in the product.
Price (1990)	Do it right first time.

3 - Value-based definition.	
Deming (1986)	A predictable degree of uniformity and dependability at low cost and suited to the market.
Garvin (1988)	Quality is measured by the percentage of scrap or rework required during the production process.
Ishikawa (1990)	Quality management is a revolutionary management philosophy characterised by the quality strategic goals
Kanji (1990)	Quality is to satisfy customer's requirements continually; TQM is to achieve quality at low cost by involving everyone's daily commitment.
Feigenbaum (1991)	Quality is the degree to which a specific product conforms to a design or specification.
Dale (1991)	Quality must be achieved in five basic areas: people, equipment, methods, materials and the environment to ensure customer's need are met.
Taguchi (1996)	The quality of product is the minimum loss imparted by the product to the society from the time the product is shipped.

There are some more precise terms and descriptions are gaining international acceptance: -

- **Quality management**

That aspect of the overall management function that determines and implements the quality policy.

- **Quality policy**

The overall quality intentions and direction of an organisation as regards quality, as formally expressed by top management

- **Quality assurance**

All those planned to provide adequate confidence that a product or service will satisfy given requirements for quality.

- **Quality control**

The operational techniques and activities that are used to fulfil requirements for quality

- **Quality system**

The organisational structure, responsibilities, procedures, processes and resources for implementing quality management

- **Quality plan**

A document setting out the specific quality practices, resources and sequence of activities relevant to a particular product, service, contract or project.

- **Quality audit**

A systematic and independent examination to determine whether results comply with planned arrangements and whether these arrangements are implemented effectively and are suitable to achieve objectives.

References

Crosby, (1979), "Quality is free", Mc Graw - Hill, New York

Dale, B.G. and Plunkett, J.J. (1991), "Quality Costing", Chapman and Hall, London.

Deming, E., (1986), "Out of the crisis", Cambridge, Massachusetts

Feigenbaum, (1991), "Total Quality Control (3rd edition)", Mc Graw-Hill, New York

Garvin, D. H., (1988), "Managing Quality: The Strategic and Competitive Edge", New York, The Free Press.

Ishikawa K., (1990), "Introduction to Quality Control", London, Chapman and Hall.

ISO 8402, (1986), "Quality Vocabulary, International Standard Organisation", Geneva

Juran J. M., (1988), "Quality Control Hand book", Mc Graw - Hill

Kanji, G. K., (1990), " Total Quality Management, The second Industrial Revolution", Total Quality Management, Vol. 1, No. 1, pp. 3-21.

Morris, B., (1992), "Total Quality Management", International Journal of Health care Quality Assurance, Vol. 2, No. 3, pp. 4 - 6.

Oakland, J, S., (1993), "Total quality management - The route to improving performance", Butterworth – Heinemann.

Price, R.C. and Gaskill, G.P. (1990), "Total quality management in research philosophy and practice", in Oakland, J.S. (Ed.), Proceedings of the 3rd International Conference on Total Quality Management, Warwick, IFS Ltd, Bedford.

Taguchi, (1996), "The Taguchi approach to parameter design", ASQC quality congress transaction, Anaheim

APPENDIX 3.1

FIVE DISCIPLINES

- **Systems thinking**

System thinking is a conceptual framework that has been developed in an attempt to clarify how the patterns of inter-correlated actions within a system affect the entire system, and thus it provides ideas for how to change the system effectively. This is the fifth discipline, according to Senge, the most important discipline, because it suggests that the five disciplines must be viewed as part of a larger system, and any attempt at creating a learning organisation must start from the premises of the organisation as a system.

What Senge stresses in his account of what constitutes a learning organisation is how systemic orientation integrates the disciplines into a coherent whole that exceeds the sum of its parts. He believes a vision without systems thinking ends up glorifying the future without understanding the forces that must be over-come in order to arrive there. However, just as important, systems thinking need the other disciplines to realise its potential:

- Building a shared vision is necessary for fostering a long-term commitment;
- Mental models contribute to the openness needed to see reality for what it is and unearth the organisation's present short-comings;
- Team learning develops the skills necessary for people to see beyond themselves and focus on the organisational perspective;
- Personal mastery is important for developing the personal motivation to try continuously to understand how we as individual's influence and are influenced by our surrounding environment.

It must be emphasised that Senge sees systems thinking as the foundation upon which a learning organisation must be founded. At the heart of the learning organisation is a shift of mind – from seeing ourselves as separate from the world to connected to the world, from seeing problems as caused by someone or something “out there” to seeing how our own actions create the problems we experience (Senge, 1990).

- **Personal mastery**

Personal mastery is “the learning organisations spiritual foundation” (Senge, 1990). It refers to a personal commitment of continuously clarifying and deepening your personal vision, of focusing your energies, of developing patience, and the ability to see reality as objectively as possible. Senge (1990) argues that the organisation’s commitment and capacity for learning can be no larger than that of its members. He argues further that few organisations focus on encouraging the personal growth of its members, and that this results in vast untapped resources not being developed. It is not quite clear how personal mastery can be fostered throughout an organisation, except through key people modelling behaviours and attitudes that reflect their personal commitment to growth and development. Organisations can learn only if the individuals in them are learning. “Personal mastery” is the phrase used to describe the discipline of personal growth, the goal of which is to expand one’s ability to produce desired results.

- **Mental models**

A mental model is another word for world-views, narratives, organisational Gestalts, or organisational cognitive structures. It refers to deeply held assumptions or metaphors through which we interpret and understand the world, and take action. Senge argues that many new insights into new market opportunities or outdated managerial practices fail to be put into practice because they conflict with strongly held, unconscious mental models.

Mental models govern how we make sense of the world and how we take action in it. An easy example is the generalisation “people are untrustworthy”. Such a sentiment shapes how we act and how we perceive the acts of others.

- **Building shared vision**

Building shared vision is important for bringing people together and to foster a commitment to a shared future. According to Senge, this idea of leadership has inspired organisations for thousands of years, but what have been lacking are principles and guiding practices for translating a personal vision into a truly shared vision. He believes that a shared vision for the organisation must transcend a charismatic leader or a galvanising crisis that brings people together temporarily, and binds people together around a common identity and a sense of destiny. Building a shared vision must start

with a personal vision to which one is committed. It is only through personal choice that people can become committed to a shared vision. Governing ideas can be used to aid in this process, ideas about future states, purposes, and values. However, it is not enough to state governing ideas, they must be the ideas by which key people in the organisation live. Shared vision is vital for learning organisations that want to provide focus and energy for its employees.

- **Team learning**

Team learning is vital according to Senge (1990) because in a modern organisation, teams are the fundamental learning units. The paradox of teams is that they can both perform well below or well beyond the capacity of any one individual. Senge feels the discipline of team learning confronts this paradox. Further, team-learning starts with “dialogue” which is the ability of team members to suspend assumptions and judgement and enter into a free flowing dialogue in which different ideas can be explored together. This means that it is essential to develop an understanding of the practices that encourage as well as hamper such a dialogue. Research into techniques and practices of dialogue have been initiated through the dialogue project at MIT’s organisational learning centre (Isaacs, 1993).

Team learning is really the process of aligning a team to avoid wasted energy and to create the results its members want. Team learning builds on the disciplines of shared vision and personal mastery, because talented teams are, necessarily, made up of talented individuals.

Reference

- Isaacs, W. N., (1993), “Taking flight: dialogue, collective thinking, and organisational learning”, *Organisational Dynamics*, pp. 24-39.
- Senge, P., (1990), “The Fifth Discipline: the Art and Practice of the Learning Organisation”, Doubleday Currency, New York, NY

CONCEPTUAL FRAMEWORK ELEMENTS

4.1.1 Technologies and tools elements

4.1.1.1 First wave elements

- **Single-loop learning**

Single-loop learning primarily concentrates on specific activity or direct effect. According to Dodgson (1993) single-loop learning can be equated to activities that add to the knowledge base or organisation-specific competences or routines without altering the fundamental nature of the organisation's activities. Single-loop learning has also been referred to as lower-level learning by Foil and Lyles (1985) adaptive learning or coping by Senge (1990) adaptive/maintenance learning; learning from experience; coping by Dixon (1993) and non-strategic learning by Mason (1993). Adaptive learning is usually fairly straightforward. The organisation identify a problem or a gap between where it is and where it want to be, and set about to solve the problem and close the gap.

Many authors for example, (McKee, 1992; Nonaka and Takeuchi, 1995; Slater and Narver, 1995) believe that the Single-loop learning is the most fundamental and passive learning style. With Single-loop learning the organisation finds out a solution to differentiate the results and the expected outcomes, but does not analyse their causes. The errors are tracked down and corrected within the existing set of rules and norms because the organisation concentrates on what is already being done. Single-loop learning is related to individual activities directed towards providing a solution to specific problems and can be associated to a linear process of innovation. For example, when a product manager sees that new product sales have fallen below expectations, he/she may inquire into the shortfall, hoping to uncover the reason and adjust the organisation's marketing strategies to bring sales performance back in line (Argyris and Schon, 1996). While the single-loop learning process is open to feedback, it does filter incoming information through current norms or capabilities, which can cause problems to be hidden, disguised, or denied (McKee, 1992).

Because single-loop learning focuses on immediate problems and opportunities it limits knowledge development and behaviour modification to the task at hand, which may

speaking to why so many organisations employ the same organisational learning techniques time and time again.

- **Problem solving**

Problem solving is bringing a group of individuals together to analyse a situation, determine the real problem, look at possible solutions, evaluate these solutions, and choose the best one for the given situation (Jay, 1997).

Systematic problem solving relates to the philosophy and methods of the quality movement relying on the scientific method, rather than guesswork, uses actual data, rather than assumptions, and simple statistical tools for diagnosing problems (Garvin, 1993). One example of this is Deming's cycle, i.e. Plan, Do, Check, and Act. The organisation has to introduce mechanisms to collect data on which decision-making and problem solving can be based. These include the introduction of various quality oriented programmes; quality history sheets; or a customer feedback study to determine which of their products were in demand and why?

Most training programmes focus primarily on problem solving techniques, using exercise and practical examples. These tools are relatively straightforward and easily communicated. The necessary mind-set is more difficult to establish. Accuracy and precision are essential for learning. Employee commitment is a must. If there were a problem that the employees do not care about, it would not be sensible for them to be involved in the problem solving process.

The problem-solving process will most likely increase the motivation and satisfaction not only of employee, but also of the management. It will give the employee a chance to voice their ideas and be listened to. This will also give them a feeling of participation by having input into the solution. Many managerial studies have found a direct correlation between employees' motivation, satisfaction increased, and productivity (Jay, 1997).

- **Benchmarking**

Bendell *et al.* (1993) define benchmarking as the process of identifying and learning from best practices anywhere in the world in the quest for continuous improvement. Rank Xerox, provides the most practical definition; benchmarking is a continuous, systematic, process of evaluating organisations recognised as industry leaders, to

determine business and work processes that represent best practices, establish rational performance goals (Zairi, 1994). The primary objective of benchmarking is performance improvement. Identifying opportunities for performance improvement by comparing one organisation's performance with that of another is a reflex of learning organisation. Benchmarking is the internal/external activity for identifying opportunities and ensuring that the wheel of improvement is turning in the right direction and is making the necessary effort towards the end destination, i.e. achieving high standards of competitiveness. Many best organisations are using benchmarking as a tool for obtaining the information to be used in the continuous improvement process, and to gain competitive edge (Booth, 1995; McNair and Leibfried, 1992).

Benchmarking is an ongoing investigation and learning experience that ensures that best industry practices are uncovered, analysed, adopted and implemented (Camp, 1989). It is a discipline process that begins with a thorough search to identify best-practice organisations, continuous with careful study of one's own practice and performance, progresses through systematic site visits and interviews, and concludes with an analysis results, development of recommendations, and implementation. Customers are one of the sources of ideas. Conversation with customers invariably stimulates learning; they are after all experts in what they do. Customer can provide up-to-date product information, competitive comparisons, insights into changing performance, and immediate feedback about service and patterns of use. Organisations need these insights at all levels, from the executive suite to the shop floor.

- **Action learning**

Bourner *et al.* (1996) describe the approach of action learning as the process of reflection and action, aimed at improving effectiveness of action where learning is an important out-come. The approach involves testing out ideas and then modifying the respective ideas as a consequence. Sandelands (1998) views action learning as a form of learning by doing, i.e. working on real life issues, focusing on learning and implementing pragmatic solutions.

Action learning is concerned with generating new ideas by putting them into natural experience, seeking to make meaning from experience (Raelin, 1997). The action learning approach suggests that people learn best about work, at work and through work, within a structure, which encourages learning (Peters, 1996).

Limerick *et al.* (1994) cited Pedler's description of action learning as an approach to the development of people in organisations, which takes the task as the vehicle for learning. It is based on the premise that there is no learning without action and likewise no sober and deliberate action without learning. It results both self-development and organisational development.

In order for the process of action learning to happen, each participant must select a problem. It may sound like an exercise in semantics; however, in action learning there is a clear distinction between a puzzle, which usually has one "correct" answer, and a problem, which may have a number of different answers.

Action learning is single-loop learning because the opportunity to reflect on experience with the support of others followed by action means that members engage in learning from repeating previous patterns of behaviour. Action Learning satisfies both individual and team learning needs by providing effective ways of identifying and addressing these needs in the workplace. Action learning is providing means for the creation and development of new skills, ways of working and approaches.

- **Continuous improvement**

Continuous improvement means incremental improvement of products, processes, or services over time, with the goal of reducing waste to improve workplace functionality, customer service or product performance (Suzaki, 1987). Process subjected to analysis by this concept characteristically reveals significant opportunities for reductions in process time or expense, and improvements in quality or customer satisfaction. Continuous improvement principles, as practised by the most devoted manufactures, result in astonishing improvements in performance that competitors find nearly impossible to achieve.

So far, continuous improvement principles are mainly applied in manufacturing industries and then predominantly in repetitive environments. There is growing interest in applying continuous improvement principles to product development and innovation processes (Barthezzaghi *et al.*, 1998). The common basis of these studies is that the successful application of continuous improvement to non-repetitive activities requires a deep understanding of the processes of focused improvement over time (Hayes *et al.*,

1988). Many authors have highlighted that sequences of learning cycles are the basis of continuous improvement (Deming, 1986; Bessant *et al.*, 1994).

- **Learning cycle**

Figure 4.1.1 illustrates the typical elements of a learning cycle (Handy, 1995). As Senge stated, “all in the organisation must master the cycle of thinking, doing, evaluating, and reflecting. Without, there is no valid learning” (Senge, 1990).

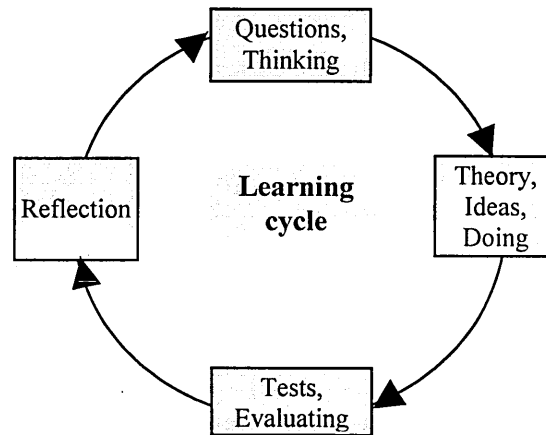

Figure 4.1.1: Learning cycle.

There is a general progression through these stages as shown by the arrows. Such learning occurs continuously, largely through social processes, and is primarily tacit in most organisations. This permeates the organisation, existing at multiple levels in the organisation ranging from individual to organisational. Therefore, the organisational learning cycle articulate as a process, which can be applied to a specific learning unit to develop organisational learning skills.

- **Data management**

Data in general refers to a collection of facts, which may or may not be related. A unit of data is quantitative or qualitative description of a physical or abstract entity. A unit of data compromise two elements one is the name of the attribute referred to; the other is the value of that attribute for a given entity. For example the attribute is monthly salary and the value is £1000 (Kenneth, 1999). Data is raw. It simply exists and has no significance beyond its existence. It can exist in any form, usable or not. It does not have meaning of itself (Gene Bellinger, 1997).

Data are carriers of knowledge and information a means through which knowledge and information can be stored and transferred. Both information and knowledge are communicated through data, and by means of data storage and transfer devices and systems. In this sense, a piece of data only becomes information or knowledge when it is interpreted by its receiver (Kock Jr *et al*, 1996). In the same sense, information and knowledge held by a person can only be electronically communicated to another person after they are encoded as data. Printed-paper and computer disks are examples of data storage devices. A corporate e-mail and the international airmail systems are examples of data storage and transfer systems. Data management is defined as the process of collecting, analysing and interpreting related data to the causes of variations in organisation characteristics (Gene Bellinger, 1997).

4.1.1.2 Second wave elements

- **Double-loop learning**

Double-loop learning is described as the second or the higher-level learning (Fiol and Lyles, 1985), generative learning (or learning to expand an organisation's capabilities) (Senge, 1990), anticipative/innovative learning or productively creating (Dixon, 1993) strategic learning (Mason, 1993). However double-loop learning is about changing the organisation's knowledge base or organisation-specific competence's or outlines (Dodgson, 1993).

With double-loop learning, the errors are tracked down and corrected, and accordingly organisation incorporates changes in its fundamental rules and norms involving action and behaviour (Argyris and Schon, 1978). It questions the overall effectiveness of current norms, values and practices, and suggests that fundamental changes may be required to improve performance. For example, after introducing the concept of the learning organisation, Federal Express challenged employees to rethink its delivery process for a major bio-chemical customer. As a result, employees mapped-out a new delivery system in just two days, which saved the customer \$1.3 million a year. Using double-loop learning, the employees solved a problem in a few days instead of nearly two years (Worrwill, 1995).

Double-loop learning is more related to iterative models of innovation. Innovation processes cover the stages of new product, service or process development, from idea conception to market acceptance and should perform the activities of prototype

development, testing, production and commercialisation. Innovation is an iterative, double-loop organisational learning process that, undertaking short-term specific activities, overcomes problems and, in the long term, modifies the fundamental rules and norms underlying actions and behaviours (culture). Hence, innovative organisations have to consider that problems lead, on the one hand, to individual actions to solve them and, on the other hand, to a collective reflection of the problem itself, of its causes and of the possible strategic options that may provide a solution to it.

- **Learning orientation**

Learning orientation is an organisational characteristic that affects the organisation propensity to value double-loop learning. Learning orientation is reflected by a set of knowledge-questioning values (Sinkula *et al.* 1997) and is a set of critical dimensions of organisational learning. Learning orientations are the values and principles that reflect where learning takes place and are the methods of sharing, developing, and utilising knowledge (Nevis, 1995). It defines the organisation's values, principles, and actual venue where learning takes place within an organisation; it is the organisation's learning personality.

For example Nevis, (1995) documented seven learning orientations that can be used to describe an organisation. These are:

- Knowledge source: internal-external, is there a preference for developing knowledge internally or acquiring knowledge developed outside the organisation?
- Product-process focus: what? -How? A focus on the product or service itself, or on how it is produced or delivered.
- Documentation mode: personal-public, knowledge is possessed by individuals or is publicly available.
- Dissemination mode: formal-informal, formal and prescribed methods of sharing knowledge or an informal casual process based on daily interaction.
- Learning focus: incremental transformative, incremental or corrective learning versus transformative or radical learning.
- Value-chain focus: design-deliver, a focus to invest learning activities in design/production or in sales/service functions.
- Skill development focus: individual-group, a focus on the development of individual skills versus team or group skills.

Learning orientation is conceptualised as a set of values that influence the degree to which an organisation is satisfied with its theories in use (Argyris and Schon 1978). Organisations with strong learning orientations encourage, or even require, employees to constantly question the organisational norms that guide their learning process activities and organisational actions (Garvin 1993). In this respect, learning orientation affects the degree to which organisational members are encouraged, even required, to “think outside the box.” Hence, it has a direct bearing on the degree to which higher order learning occurs (Slater and Narver 1995).

A learning orientation is likely to increase the rate of internal and external change in an organisation, but the process of establishing a learning orientation takes time. Changes in an organisation’s learning orientation, as Garvin (1993) noted are “the product of carefully cultivated attitudes, commitments, and management processes that have accrued slowly and steadily over time”.

- **Information system**

An information system is a specific kind of a technology. Dodgson (1993), Brown and Puguid (1991) merely make a passing mention of the influence of technology on learning. Both suggest that new technologies such as multimedia communications, computer-aided learning, information dissemination and training will be a great ground for future research in this area. Gershman (1993) states that technology can be used to clarify assumptions, speed up communications, elicit tacit knowledge, and construct histories of insights and catalogue them. The influence of information systems, in particular, can be considered two-fold: direct influence and indirect influence. Information systems can indirectly influence organisational learning by affecting contextual factors such as structure and environment, which, in turn, influence learning. They can also directly influence the organisational learning processes. For example, in recent time information systems may be viewed as database, which allows a result to conduct transactions.

Learning is important for organisations to survive and sustain competitive advantage and promote innovation. Information systems can enable this survival strategy, the innovative spirit, and the competitive edge.

- **Information management**

Information is a basic resource like materials, money and personnel. Information can be considered either as an abstract concept (ideas) or as a commodity, usually in the form of letters and reports. Information is a data that has been directed to the right place (or person) at the right time (or decision instant). Information is data that has been given meaning by way of relational connection. This “meaning” can be useful, but does not have to be (Gene Bellinger, 1997). Essentially, therefore, information has become a critical resource, just like energy, both of which are vital to the well being of individuals and organisations in the modern world.

Information management has been defined as the organisation-wide capability of creating, maintaining, retrieving and making immediately available the right information, in the right place, at the right time, in hands of the right people, at the lowest cost, in the best media, for use in decision making (Langemo, 1980). In the same vein, Best (1988) defines information management as the economic, efficient and effective co-ordination of the production, control, storage and retrieval and dissemination of information from external and internal sources, in order to improve the performance of the organisation. Therefore, the key issue involved in information management is managing information in an organisation using modern information technologies.

Garvin, (1988), found that high quality performance organisations generate, process, and distribute more information about their products, processes, and failure-rates than low quality performance organisations. For example, leading edge quality organisations, such as Xerox, Federal Express, and Texas Instrument, generate and process scores of pieces of information to create useful knowledge about customer satisfaction and the quality and the performance of their products and services (Fortune, 1993).

Practically speaking, any organisation needs information both about its own internal processes, in order to ensure effectiveness and efficiency, and about its environment, in order to respond and adapt to the actions, attitudes and decisions of external agencies such as governments, competitors and social groups. Both types of information must be put together in a coordinated manner so that the actions and decisions of the organisation can be matched closely to its external circumstances.

4.1.1.3 Third wave elements

- **Triple-loop learning**

According to (Argyris and Schon, 1996) triple-loop learning is the most advanced level of learning that seeks to gain insight into the “learning process” itself while addressing the problems or opportunities at hand. This learning level is required when the existing knowledge is no longer adequate in order to reach the objectives. There is a need for a complete change and renewal, which requires the individual to reflect on its mental models, thereby learning to learn new things (Argyris & Schon, 1978). Triple-loop learning involves learning how to learn and it requires organisational members to inquire into the nature of their learning system and its effects on their inquiry.

Argyris & Schon (1978) and Swieringa and Wierdsma (1992) distinguish between three levels of learning – single-loop learning: questioning how things are done; double-loop learning: questioning underlying purposes and why things are done; and triple-loop learning: questioning essential principles on which the organisation is based, and challenging its mission, vision, market position and culture. Double-loop and Triple-loop learning are concerned with the why and how to change the organisation while single-loop learning is concerned with accepting change without questioning underlying assumptions and core beliefs. A major benefit of the learning processes, according to Schrage (1989), is that “organisations that learn how to fail intelligently outperform organisations that seek to minimise the frequency of failure.”

While each learning process creates varying degrees of information, this review suggests that Triple-loop learning may offer more value to organisations challenged with generating a steady stream of product innovations. The missing ingredient has been the lack of field-testing to evaluate the linkage between organisational learning, total quality management, knowledge development and organisational behaviour.

- **Knowledge management**

Knowledge is the appropriate collection of information, such that it’s intent is to be useful. Knowledge is defined as a set of beliefs held by an individual about causal relationships among phenomena (Sanchez *et al.*, 1996). Knowledge can be viewed as the interpretation of the information.

Knowledge (broadly conceived to include both what we know and what we can do) indicates a state, i.e. a person or organisation has a certain measure of knowledge, which creates the potential for action and decision. Learning indicates some change in the state of knowledge, which is often manifested, by a change in explanation, decision or action. Learning must involve an increase in knowledge or a change in something previously known (i.e. we correct an error or change from one theory to another).

Knowledge management has been broadly defined as “the acquisition, sharing and use of knowledge within organisations, including learning processes and management information systems” (University of Warwick, 1999) or, more specifically, knowledge management is a knowledge creation, which is followed by knowledge interpretation, knowledge dissemination and use, and knowledge retention and refinement (De Jarnett, 1996). Knowledge management is the process of critically managing knowledge to meet existing needs, to identify and exploit existing and acquired knowledge assets and to develop new opportunities (Quintas *et al.*, 1997).

The purpose of knowledge management is to integrate internal and external knowledge at all times in order to cope with environmental changes both within and outside the organisation, to solve existing problems as well as to innovate for organisation expansion. However, to fulfil these functions, the organisation has to provide a learning process to speedup the flow of information.

To enhance organisational learning ability is to practice knowledge management. A good knowledge management system not only helps establish internal consensus and a competition mechanism, but also contributes to corporate competitiveness and adaptability in the face of rapid external changes. Therefore, the knowledge management system in a learning organisation must be able to coordinate work and learning activities, and it should contain enough stimuli or incentives to attract all members to get involved in learning activities (Quintas *et al.*, 1997).

4.1.2 Organisation and systems elements

4.1.2.1 First wave elements

- **Culture**

Culture can be defined as, a pattern of basic assumptions invented, discovered, or developed by a group as it learns to cope with its problems of external adaptation and

internal integration that has worked well enough to be considered valid and, therefore, to be taught to new members as the correct way to perceive, think, and feel in relation to those problems (Schein, 1985). Learning culture support shared learning from experience to perceive and understand a new vision. The learning culture of an organisation can be considered as “a constantly changing, multi-faceted organism, which draws on the collective energies of the learning conditions of its people” (Johnson and Scholes, 1993).

Culture is the first aspect, which needs to be appraised with a view to establishing the current state of learning in the organisation. Culture means the way in which learning is viewed, talked about and interpreted in the organisation. Culture is something that every person in the organisation contributes to and has a role in either perpetuating or changing over a very long period of time. Implementing organisational learning in any organisation requires a large amount of change. People behaviour and attitudes must change. Manager and staff must be able to do their jobs more skilfully. New attitudes are needed which stress the importance of meeting customer requirements. Culture change is therefore a sensitive issue and management must lead the whole process all the time.

- **Organisation structure**

A critical issue concerning the process of organisational learning is the effectiveness of the organisation at processing information and influencing different factors throughout the organisation. One of the structural determinations is the structure of the organisation (Foil and Lyles, 1985). Organisation structure can be defined as the arrangement among people in order to get work done (Perrow, 1967). The organisation structure can be viewed as a facilitator of interaction and communication within the organisation to control and coordinate the organisation’s activities.

Organisational structure is characterised by its size, its degree of specialisation and integration, its configuration of positions, information flow and location. The division of functions among the departmental sub-structures in the organisation and their specialisation characterises the way organisations’ activities are structured (Pugh and Hickson, 1976; Pugh *et al.*, 1988). An additional characteristic of the structure is the stability of configuration of positions. Intensive changes lead to instability of all processes in the organisational and the management block. With regard to the

communication system, two essential characteristics are specified: information supply (i.e. the structure of information channels and the continuity of information flow, the nature of the information itself and the degree of formality (Arnold and Feldman, 1988).

A useful way to conceptualise organisational structure is from an information processing view. The key characteristic of such structure is that it links the various elements of the organisation through the transformation of information. The structure of the organisation provides channels of communication through which information flows in the organisation (Duncan and Weiss, 1979). An appropriate structure can foster the information processing cycle, a process that requires significant human interactions.

- **Communication**

Communication is part of the cement that holds together the bricks of the learning process supporting the principle of organisational learning. Communication is vital in the empowerment process. If employees are to share the decision-making in the organisation, they must know and understand organisation objectives and values, and have access to the information relevant to their area of responsibility. Communication is defined as the process by which an idea is transferred from a source to a receiver with the intention of changing his or her behaviour. Thus, effective communication results in changes intended by the information source (Rogers *et al.*, 1976).

In addition to traditional forms of information distribution such as telephone, facsimile, face-to-face meetings, and memorandums, computer-mediated communication systems such as electronic mail, bulletin boards, computerised conferencing systems, electronic meeting systems, document delivery systems, and workflow management systems can facilitate the sharing of information. Studies have shown that such systems increase participation and result in better quality decisions since decisions are made by consensus and not by domination (Hiltz & Turoff, 1993). These systems, also called groupware or collaborative systems, allow the joint interaction and distribution of experiences and insights. They also enable social contraction or the creation of social networks of members narrating and sharing their stories. These systems can also support feedback and review mechanisms among members of a team. Thus, they not only support communication but also collaboration. The development of such information systems-enabled communities results in better interpretation of information and greater understanding. In addition, groupware enables equal participation at all levels and

supports members learning from each other simultaneously (unlike traditional learning systems which are usually top-down and time-consuming) thereby reducing cumulative learning cycle time. Group calendars and workflow management systems can help ensure the timely participation of members in the learning exercise.

Communication needs to be clear, fast and focused to transfer knowledge across departmental boundaries and to transfer knowledge from the external environment, e.g. from suppliers, customers and even from benchmarking of competitors (Garvin, 1993). The amount of information flow or communication between organisational units and individuals determines learning. Poor communication between people and organisational units can be a major block to learning and quality improvement.

- **Shared vision**

Shared vision is the process whereby the personal views of key leaders are translated into forms that can be shared by all members of the organisation (Senge, 1990). He believes that “a shared vision for the organisation must transcend a charismatic leader or a galvanising crisis that brings people together temporarily, and binds people together around a common identity and a sense of destiny”. Building a shared vision must start with a personal vision to which one is committed. It is only through personal choice that people can become committed to a shared vision.

Shared vision is vital for organisations that want to provide focus and energy for its employees. People learn best when they strive to accomplish things that matter to them. In fact, you cannot have a learning organisation without shared vision. The overarching goal that the vision establishes brings about not just commitment but new ways of thinking and acting. It fosters risk-taking and experimenting. It also encourages a commitment to the long term. Learning strategy can be determined essentially by leadership at the top or be incrementally emergent, involving a number of layers of management.

Mastering the discipline of shared vision means you have to give up the idea that visions come from top management or from an institutionalised planning process. To begin the process of encouraging vision, leaders must instead share their personal visions and ask that employees follow them. Leaders must ask for support, then be patient as the shared vision takes time to emerge. It will grow as people interact with

their own visions – as people express their dreams and learn how to listen to the dreams of others. When listening, new insights and beliefs as to what is possible will surface.

- **Performance management**

Rogers S., (1994), argue that performance should be defined as the outcome of work because it provide the strongest linkage to the strategic goals of the organisation, customer satisfaction, and economic contributions. Performance management is an approach to management, which harnesses the endeavours of individual managers, and workers towards organisation's strategic goals. It defines goals and the outputs needed to achieve those outputs, and monitors outcomes. Performance management is an integrated set of planning and review procedures, which cascades down through the organisation to provide a link between each individual and the overall strategy of the organisation (Rogers, 1994).

A typical statement of the goals of performance management is expressed in question form by Walters (1995a):

- What are organisational objectives? What do we wish to achieve and over what time-scale?
- How do we prioritise objectives? Do we expect prioritisation to change over time?
- What kinds of qualities are needed to deliver these objectives? What are the implications in terms of corporate skills and competencies, values, behaviours and working styles?
- What are our current strengths and weaknesses in relation to these objectives? What do we need to change or develop in order to achieve our goals?
- What specific contributions do we require from particular parts of the organisation?

Most organisations can benefit from a periodic review of this kind. However, as detected in the following the outcome of such review a more prescriptive model of a performance management system emerges (Walters, 1995b):

- “Establish a portfolio of measures, quantitative and qualitative, designed to track both inputs and outputs
- Forge forward-looking appraisal schemes, underpinned by clear and precise information, to enhance everyday management activities throughout the year
- Design up comprehensive personal development plans based on careful analysis of opportunities and needs.
- Encourage learning and development, overcome the obstacles to learning and evaluate the results
- Design and implement schemes for performance-related pay, which motivate and reward employees for achieving corporate goals.”

Any enterprise would benefit from clarifying goals and monitoring progress. It is with the prescribed formula for controlling performance that there are difficulties.

4.1.2.2 Second wave elements

- **Fostering new ways of thinking**

This can be described as a learning process which deliberately; creates opportunities for informal employee learning, both “on the job” and “off the job”; and stimulates employees not only to attain new knowledge and skills, but also to acquire skills in the field of learning and problem solving and thus develop their capacity for future learning, or “learning to learn” (Tjepkema and Scheerens, 1998).

Thus, fostering new ways of thinking seeks to become one of the critical elements of a learning organisation, and attempts to achieve this by supporting individual lifelong learning, whether formal or informal, and by encouraging the sharing of this learning in order that all members of the organisation might learn and change and improve performance (organisational learning and development).

- **Change organisation’s potential behaviour**

In an attempt to define organisational behaviour, Financial Times Mastering Management series pointed out (1997) that: “organisational behaviour is one of the most complex, but perhaps least understood academic elements of the modern general management, but since it concerns the behaviour of people within organisations it is also one of the most central, its concern with individual and group patterns of behaviour makes it an essential element in dealing with the complex behavioural issues thrown up

in the modern business world". Organisational behaviour particularly relates to setting business goals and performance measure, which have a significant influence on decision-making and action-plans.

While there is a tendency to state that organisations do not learn, people do; the organisational potential behaviour emphasised as the basic unit of analysis. Morgan (1997), consider the notion that organisations learn, as opposed to individuals in organisations learning together, which introduces an unnecessary level of abstraction to the debate.

The notion of the learning organisation is unhelpful if it leads to the attribution to the organisation of systems properties, which are in some way independent of its members. Viewing organisations as systems is essentially adopting the metaphor of organisations as organisms. Such a metaphor has significant limitations primarily its assumption of functional unity, whereas in reality organisations are not normally characterised by harmony.

4.1.2.3 Third wave elements

- **Establish learning communities**

The learning community is a vehicle for meaningful involvement of community residents, program participants, clients and other stakeholders in program activities and the assessment of program performance. The learning community strategy is not a substitute for conventional evaluation designs (Daniel *et al.* 1997). It assumes that traditional data collecting methods are available as a source of information for learning community dialogues. A learning community dialogue provides space for stakeholders to continuously examine and negotiate programme goals, activities and desired outcome within an atmosphere of trust, collaboration and inquiry into producing effective results.

- **Learning strategy**

Learning strategy is not only regenerative for the organisation, but is also a learning activity. The importance of a learning dimension in the strategy process is one of the critical elements to implement organisational learning. Strategy is the key link between theory and practice, and it is what relates the team to its role within the organisation. Hayes, (1988), observed, "unless one understands how an organisation got where it is, it is difficult to determine the appropriate steps to take next. If not properly understood,

the forces that drive it in a certain direction will continue to operate, despite whatever well intentioned decisions are imposed upon it”

Strategy can be determined essentially by leadership at the top or be incrementally emergent, involving a number of layers of management. The important point to note in relation to organisational learning is that strategic decisions, like all decision-making, turn a complex of information inputs into action.

4.1.3 People

The people element is common to all three waves of quality. However the nature and emphasis of these elements would have different degree of weighting (involvement) for the each wave of quality.

- **Leadership**

Leadership is the necessary mediating function between the organisation and its members, imprinting on both e.g. (Schein, 1988). Schneider depicts as (yet again) a circular model of attraction-selection-attrition (Schneider, 1987; Schneider *et al.*, 1995). Leadership play a key role in reshaping and transforming shared mental models. Leadership is mentioned by virtually all writers as an important element in fostering a learning climate through their behaviours, such as seeking feedback, being open to criticisms, admitting mistakes and empowering their employees to make decisions and take some risks (Garvin, 1993). The role of the leader in facilitating movement through the learning process, by interacting with individuals and teams, is crucial for success.

In a learning organisation, a leader is not just a charismatic decision maker but also a teacher, a designer, and a steward of change (Senge, 1990). The essential function of leadership is to build an organisation quotes culture and shape its evolution. Leaders are designers who help build a strong foundation of purpose and core values. They should shape the design of the organisational structure and policies so as to best fulfil the corporate mission. Leaders should foster systems thinking and system dynamics to facilitate both individual and organisational learning (Stata, 1989). System dynamics can be used as a training tool while planning and quality improvement can accelerate organisational learning. Leaders as teachers should help individuals restructure their views of reality by identifying and challenging prevailing mental models and

fundamental assumptions and by promoting double-loop learning. Leaders as stewards should have a sense of purpose and commitment to the organisation's larger mission.

- **Management responsibility**

The role of managers in change and managerial commitment to change are key concerns for organisations. Commitment has become an element of the dynamics of business strategy (Ghewamat, 1991). Any type of change requires managerial support and commitment, in essence, a powerful actor for leading and accomplishing change efforts. In organisational behaviour, managing organisational change is one of the key issues.

The implementation of TQM is an organisational change process that involves learning and often requires an extensive cultural change. In this process, managers are responsible for the improvement of management systems; collaborative/participatory management style seems to be essential for the process of implanting new ideas and practices.

Managers are assumed to be loyal professionals dedicating themselves to the organisation's goals. Research is especially needed to increase the understanding of the managerial commitment process in the context of change. The issue related to commitment formation is: what are the behavioural consequences of commitment? For example, what is the relationship between commitment and learning in organisational change processes; do they reinforce each other? How does a varying "psychological bond" affect a learning process? Management is a natural part of these processes by which different types of organisational issues are resolved and reformed. Therefore, the systematic evidence of the managerial behaviours stemming from commitment is needed. According to the philosophy of organisational learning managing requires new attitudes and skills from all managers.

- **Empowerment**

The term empowerment is generally used to refer to a form of employee involvement initiative. In the workplace, the term "empowerment" carries two different meanings, which are often confused: the process by which management delivers power to employees, and the process by which an employee assumes power. Much of the management literature emphasises the first of these meanings. For example, Pearn *et al.* (1995) discuss the need to both empower employees (that is, supply power) and equip

them to behave in new ways (supply the right skills and attitudes). Plunkett and Fournier (1991) describe empowerment as a mechanism for investing responsibility in individuals and teams. Quigley (1994) illustrate empowerment as a process in which power flows down from the enterprise's vision to leaders and on to those below.

Within the literature of organisational learning, there is a close link between the concepts of "empowerment" and "learning". For example, according to Watkins and Marsick (1993), "a learning organisation has a culture of empowerment". Some authors argue, "the learning organisation is the result of empowerment" (Watkins and Marsick, 1993). Pearn *et al.* (1995) echo these views: "it is not possible to become a learning organisation without a high commitment to empowerment".

The result is a self-reinforcing cycle – empowerment results in learning, which further empowers. In the role of empowered learner, employees can act autonomously and flexibly to interpret, absorb and apply knowledge (Nonaka, 1993; 1994).

- **Rewards and recognition**

Rewards and recognition are the enablers, which maximises employees' potential and involvement, and in doing so, become one of the main contributors to the organisation's journey to organisational learning. As Bennett and O'Brien, (1994) stated, "reward and recognition systems must support and encourage individual and organisational learning". Bennett and O'Brien insist reward and recognition are essential aspects of building a learning organisation. Recognition considered as one of the most important steps of the continuous improvement process. In good organisations, rewards and recognition are linked to sustaining the appropriate behaviour. Reward and recognition is an essential element of the learning process and a prerequisite to achieving and maintaining a corporate culture, which embraces the learning process. Rewards and recognition schemes must continually evolve to meet the organisation's changing needs.

- **Team learning**

A team is people doing something together. Team learning is vital according to (Senge, 1990), because in a modern organisation, teams are the fundamental learning units. The paradox of teams is that they can both perform well below or well beyond the capacity of any one individual. Senge feels the discipline of team learning confronts this paradox. Teams are social units engaged in collective learning and sites for the cross-

fertilisation of ideas and for setting learning norms (Masrick, 1994; Senge, 1990). This perspective draws attention to team members' skills and competencies as well as to informal processes linking individual and organisational learning, and the role of self-managed or self-directed teams.

The most frequently cited forms of small group/team-working are cross-functional problem solving/project teams, quality improvement teams, TQM action groups, and communication groups. A number of organisations were using more than one form of team working. The main functions reported for these groups/teams were: quality improvement, better communication, development of team-working/team spirit, and greater employee awareness of organisations' problems.

Team learning is a critical element for organisational learning to succeed. Successful organisations have teams for solving problems, for improving quality, for introducing new processes and products. Compared to employees, who work individually, effective teams tend to have higher morale and productivity, and take pride in the job and the organisation. Getting employees together in groups does not guarantee a successful outcome. Members need to work effectively as a team. Team learning is characterised as a triple-loop learning process.

- **Training and education**

Training has been identified as the single most significant factor in improving quality (Oakland, 1993). Effective training pursuits must be planned systematically and objectively. Training and education are key aspects of the learning organisation. As Gephart *et al.* (1996) note, training is a tool for learning; learning as a desired outcome influences performance improvement. Some scholars believe the goal of training and education in learning organisations is to reach the level of learning facilitation (Cusimano, 1996). Nadler (1994) argue that training leads to learning and learning leads to improved job performance. Moreover, they go on to state there are three domains of learning- skills, knowledge, and attitude. These three domains are the result of training and education, which ultimately lead to enhanced performance. McManus (1996) echoes this approach as well. He states knowledge, skills, and aptitudes are essential for organisational success and learning, and avoiding extinction, in the twenty-first century. Iles (1994) and Robinson *et al.* (1997) join the argument by emphasising that knowledge and skills must be developed in order for organisations to learn.

4.1.4 Organisational performance

Organisation hoping to become learning organisations cannot rely exclusively on the traditional measures such as cost and schedule performance, while ignoring learning that affects other variables such as quality and new product developments. Hultink and Robben (1995) concluded that performance measurement impact an organisation by shaping the behaviour of managers and employees alike. For example, the Apple Computer case, Kaplan and Norton (1993) found that measures which include financial as well as customer, innovation and learning perspectives, had benefited executives more than the pure financial measurement. Therefore two sets of performance measurements are identified to evaluate the output performance. The first set is concerned with quantifying non-financial performance. The other set include a financial factors.

4.1.4.1 Non-financial performance

4.1.4.1.1 First wave measures

A description of the non-financial measure specific to the first wave is given in the following subsections.

- **Customer satisfaction**

Customer satisfaction is a psychological concept that involves the feeling of well being and pleasure that results from obtaining what one hopes for and expects from an appealing product and/or service (WTO, 1985). Customer satisfaction can also be defined as satisfaction based on an outcome or a process. Vavra (1997) characterises satisfaction as the end-state resulting from the experience of consumption. This end state may be a cognitive state of reward, an emotional response to an experience or a comparison of rewards and costs to the anticipated consequences. Vavra, (1997) also puts forth a definition of customer satisfaction based on a process, emphasising the perceptual, evaluative and psychological processes contributing to customer satisfaction. In this definition, assessment of satisfaction is made during the service delivery process.

- **Delivery reliability**

Consistent and on-time deliveries are a key objective of world-class manufacturing. The detailed analysis of the production process that is required when total quality is

introduced has the objective of removing the variability within the production plant. As variability is reduced it becomes possible consistently to deliver the products on time.

Delivery reliability is one of the organisation's objectives is to deliver on time all the time, then this is a good, clear measure of the success or failure of that policy on a continuous basis (Brian, 1989). It is also a measure of the stability and efficiency of the total master scheduling and production planning process. In addition any unnecessary or unplanned changes to an order or a schedule is wasted effort that must be eliminated. The number of changes to customer orders, purchase orders or the production schedule is a leading indicator of the future delivery problems.

- **Order cycle time**

Order cycle time can be defined as the time from receipt of order until the product is delivered to the customer. Reducing cycle time is success because time is the ideal driver of process performance and time can be managed (Grubb, 1998). There are important distinctions between driver measures and results measures. The order cycle time is consists of two times, one is process time and the other is the delivery time.

The process time stands for the total manufacturing lead-time of a product, including the time it takes to order and receive components, the time to make sub-assemblies and the finished product assembly. This is sometimes called the cumulative lead-time of the product. The delivery time is the delivery lead-time offered to customers. This may be the delivery lead that the organisation has traditionally offered or it may be the lead-time the customer would like to have or the lead-time that would provide advantage over other suppliers. The objective of all world-class manufacturers is to so reduce their order cycle time.

- **Innovation (produce new product)**

Innovation is a crucial process for the well being of an organisation. Kay (1993) considers that innovation can be competitive advantage and the key to sustained innovation arises from the architecture of the organisation. Informal structures, speed of response and free sharing of information form part of these foundations. Managers should be able to protect, exploit and appropriate innovation and create time for individuals and groups to consider change and fund the staff resources, familiarise training needs to turn ideas into implementation. Utterback (1994) deals with issues of

strategic innovation and how technologies, and the organisations that support them, are displaced by newer technologies and new organisations. He provides histories of various product developments and how organisations have dealt with declining markets.

The importance of innovation to organisational performance has led to a growing interest in the topic by the European Commission (Commission of the European Communities, 1995) and the UK government (DTI and CBI, 1994). The DTI state that in nine out of ten “winning” UK organisations studied, the characteristics of innovation best practice are: leadership by visionary, enthusiastic champions of change; knowing their customers; constantly introducing new, differentiated products and services; delivering products and services that exceeded customer expectations; and unlocking the potential of people by good communications, team work and training, flattening the organisational pyramid and creating a customer focused culture. The relevance of innovation to business success led the UK government in 1993 to support the development of modules for the teaching of innovation on continuing education and Master's programmes in business schools. The resulting curriculum analysis and design led to a framework for innovation management training, comprising five core areas: product innovation; process innovation; technology and strategy; creative problem solving; and implementing technological innovation. Innovation together with continuous improvement requires a commitment to continuous learning otherwise organisation repeat old practices.

- **Workflow improvement**

Workflow is concerned with the automation of procedures where documents, information or tasks are passed between participants according to a defined set of rules to achieve, or contribute to, an overall business goal. A workflow management system provides procedural automation of a business process by management of the sequence of work activities and the invocation of appropriate human and or information technology resources associated with the various activity steps (Hollingsworth, 1994).

- **Data collection/processing capability**

The first step to induce learning is when an organisation introduces a data collection mechanism for decision-making and problem solving. Acquisition of declarative data or facts is achieved by monitoring the environment, using information systems to store, manage, and retrieve information, carrying out research and development, carrying out

education and training, and patent watching (Dodgson, 1993). Learning occur not only due to data collection from outside the organisation but also due to the rearrangement of existing data, the revision of previous data structures, and the building and revision of theories. According to Dodgson (1993), organisational learning occurs when it creates a database, organisation-specific competence, and routines. Database is created by acquiring, storing, interpreting, and manipulating information both from within and outside the organisation.

- **Data storing capability**

The concept of data storing capability springs from the combination of two sets of needs; the business requirement for an organisation-wide view of information and the need of the information systems department to manage organisation data in a better way. Data warehousing is one of the data storing capability. Devlin (1997) defined the data warehouse simply as a single, complete, and consistent store of data obtained from a variety of sources and made available to end users in way they can understand and use in a business context. A data warehouse is a large physical database that holds a vast amount of data from a wide variety of sources. Data warehousing consists of data importing and exporting for accessing, transforming, distributing, storing, and exporting the data.

- **Skills development**

Skill is a combination of ability, knowledge and experience that enables a person to do something well. Skills are as competences that can generate explicit knowledge. Skill is the ability to master the concepts of a discipline or domain, and to apply this knowledge appropriately in new situations. Skill is usually task-related competence (Garavan, 1991). A learning skill defines a generic heuristic that enables mastery of a specific domain.

Learning skills, however, are developed by learning from experience and as a result are more variable and subject to intentional personal development. For example, Anderson (1982) described the acquisition of cognitive skill as a “learning by doing” system that translates declarative knowledge into procedural knowledge.

4.1.4.1.2 Second wave measures

A description of the non-financial measures specific to the second wave is given in the following subsections.

- **Information acquisition capability**

The organisational learning cycle starts with the collection of information, both from internal and external sources (Dixon, 1994). Market research, corporate intelligence, and news from published sources constitute the external information source. Learning the experience of other organisation and new employees is a common phenomenon in organisations (Huber, 1991).

- **Information storing capability**

Organisational memory refers to the repository where information is stored for future use. Organisational memory can be made of both hard data such as numbers, facts, figures, and rules as well as soft information such as tacit knowledge, expertise, experiences, anecdotes, critical incidents, stories, artefacts, and details about strategic decisions (Morrison, 1993). Most organisations have various kinds of information systems such as inventory control systems, budgetary systems, and administrative systems to store and retrieve hard data or facts but do not have similar systems to capture softer information. Organisational memory plays a very critical role in organisational learning. Both the demonstrability and usability of learning depend on the effectiveness of the organisation's memory. The major challenge for organisations exists in interpreting information and creating organisational memory that is easily accessible.

- **Knowledge development**

Knowledge development actively is usually based on the difference between the needed and available knowledge. It starts from information collection and distribution, which is then given some meaning. "Interpretation is the process of translating these events, of developing models for understanding, of bringing out meaning, and of assembling conceptual schemes" (Weick and Daft, 1984). Events are translated into stories, paradigms, and frames for interpretation (Levitt and March, 1988). Insights are developed for improving existing skills and routines, understanding the cause-and-effect relationship, changing the central norms and underlying assumptions, which are

described by Argyris and Schon (1978, 1996) as “single-loop” and “double-loop” learning, respectively.

Strategic applications of information systems for knowledge acquisition can take two forms (Mason, 1993): capabilities for assimilating knowledge from outside (such as competitive intelligence systems acquiring information about other organisations in the same industry) and capabilities for creating new knowledge from the reinterpretation and reformulation of existing and newly acquired information (such as executive information systems or decision-support systems). They can also be environment scanning and notification systems, and intelligent and adaptive filters.

4.1.4.1.3 Third wave measures

A description of the non-financial measure specific to the third wave is given in the following subsections.

- **Knowledge processing/analysis capability**

How knowledge is acquired, disseminated and interpretation, is critical to organisational learning. Nonaka (1994) believes that successful organisations are those that consistently create new knowledge, are able widely to disseminate it throughout the organisation and embody it in new technologies and innovation. Huber, (1991), refers to organisational learning as the “development of insights or awareness, which is a change in states of knowledge that expands the range of potential behaviours”.

Slater and Narver (1995) suggests that organisations acquire knowledge through one of three ways: direct experience, the experience of others, and organisational memory. Direct experience can originate from within the organisation, such as corporate reports covering inventory, cost-of-good sold, sales, market-share, etc. or outside the organisation through marketing intelligence gathering and feedback systems (Kotler, 1997). Learning from others, occurs when managers interface with individuals or groups outside of the business. For example, through benchmarking, forming joint ventures, networking, making strategic alliances, and working with lead customers, who both recognise strong needs before the rest of the market and are motivated to find solutions to those needs (Slater and Narver, 1995).

Once collected, management must then disperse the knowledge on a timely basis (Cooper and Klindschmidt, 1991). They suggest that two benefits derived from enhancing the flow of communications when launching a new product are rapid decision-making or effective strategy implementation. The third stage of knowledge processing involves the ability to gain consensus on the meaning and implications of the new knowledge. Slater and Narver (1995) write, “to ensure that all information is considered, organisations must provide forums for knowledge exchange and discussion”.

- **Knowledge retrieving capability**

Organisational memory addresses the issue of how knowledge resides in the organisations. It is embedded in different entities, namely physical location, operating procedures, individuals, codes of conduct and culture. Walsh and Ungson (1991) argue, “organisational memory is both an individual and organisational level construct”. The implications for this definition of organisational memory concern the way information is stored, the types of information contained and the information acquisition and retrieval process.

- **Individual/team competence development**

Competencies defined as a system of human beings, using (hard) technology in an organised way and under the influence of a culture to create an output that yields a competitive advantage for the organisation (Drejer, 1996).

McClelland, (1993), describes competence as basic personal characteristics that are determining factors for acting successfully in a job or a situation. Individual competence are concerned with the fundamental personality characteristics that are inherent in a person’s actions in relation to all kinds of tasks and situations.

4.1.4.2 Financial performance

Unlike the non-financial measures, this report suggests that financial measures are common to all the three waves. A description of these is given in the following subsections.

- **Inventory turnover**

Inventory turnover is defined as the cost of goods sold divided by average inventory (Manuel, 1996). This is the traditional financial accounting measure to evaluate inventory management. Inventory turnover rate is the number of times that the average inventory level could be sold per year if consumed at the average annual rate (Ronald, 2000). In addition to investigating unplanned stock-outs, the inventory turnover rate should be checked at the end of each order cycle to see if it is out of control.

- **Productivity**

Productivity relates to the efficient utilisation of inputs in producing prescribed outputs of goods or services. Definitions of productivity are numerous, but in the simplest terms, productivity is measurement of output relative to an input (Siegel, 1986). The challenge for learning organisation is to minimise input for an improved output while remaining flexible and meeting customer demands.

- **Employee productivity**

Lagasse (1995) refers to two types of productivity: Productivity is in its pure sense the ratio of outputs to inputs and has been classically computed at two levels: Type I productivity, defined as employee productivity, is very specific to the type of service provided and does not allow for easy comparison across different services. An example of this would be to try and compare the number of visits per hour for primary care physicians to the number of procedures performed by a surgeon. Type II, or multi-factor productivity, is a more generic form that transforms all outputs and inputs into a common unit of measure, making comparisons across services effective. Historically, productivity has been measured accurately in manufacturing environments and, in general, poorly in service related fields due to the difficulties in measuring outputs and inputs whose work content vary widely.

- **Market share/profit**

The relationship between market share and profitability is strong and positive as evident from recent analysis of market share and profitability (Kuzma and Shanklin, 1992). They surveyed 1,000 industrial product manufacturers identified in 239 four-digit Standard Industrial Classification (SIC) codes. Focusing on improving the profitability of middle market share organisations, they found that improving product quality is the

first step toward improving profitability, and that target marketing and rapid response to change are crucial elements for success.

- **Defect rate/quality cost**

The relation between the defect rates and cost of quality is positive and very strong. Quality costing can provide a measure of quality in the language that most senior manager know best money. Quality costing puts a financial sum against people, materials, equipment and over head cost resulting from the activities relating to meeting the agreed requirements of external and internal customer. Quality costing provides a financial measure of the state of health of organisation. The aim is simple to achieve least cost to meet agreed customer requirements first time every time.

References

- Anderson, J., (1982), "Acquisition of cognitive skills", *Psychological Review*, Vol. 89 No. 4, pp. 369-406
- Argyris, C. and Schon, D., (1978), "Organisational Learning: A Theory of Action Perspective", Addison Wesley, Reading, MA.
- Argyris, C. and Schon, D., (1996), "Organisational Learning II: Theory, Method and Practice", Addison Wesley, Reading, MA.
- Arnold, H. and Feldman, D., (1988), "Organisational Behaviour", McGraw-Hill, New York, NY
- Barthezzaghi, E., Corso, M. and Verganti, R. (1997), "Continuous improvement and inter-project learning in new product development", *International Journal of Technology Management*, Vol. 14 No. 1, pp. 116-38
- Bendell, T., Boulter, L. and Kelly, J., (1993), "Benchmarking for Competitive Advantage", Pitman Publishing, London
- Bennett, J.K. and O'Brien, M.J., (1994), "The building blocks of the learning organisation", *Training*, Vol. 31 No. 6, pp. 41-9
- Bessant, J., Caffyn, S., Gilbert, J., Harding, R. and Webb, S., (1994), "Rediscovering continuous improvement", *Technovation*, Vol. 14 No. 1, pp. 17-29
- Best, D.P., (1988), "The future of information management", *International Journal of Information Management*, Vol. 8 No. 1, March, pp. 13-24.
- Booth, D., (1995), "Benchmarking – the essential phase of preparation", in Kanji, G.K. (Ed.), *Total Quality Management, Proceedings of the First World Congress*, Chapman & Hall, London.

- Bourner, T., Beaty, L., Lawson, J. and O'Hara, S., (1996), "Action learning comes of age: questioning action learning", *Education + Training*, Vol. 38 No. 8, pp.32-5.
- Brian H., (1989), "Performance measurement for world class manufacturing", *Management Accounting*, July/August
- Brown, J.S. and Pugh, P., (1991), "Organisational Learning and Communities of Practice". *Organisation Science*, 2(1), 40-57.
- Camp Robert C., (1989), "Benchmarking: The search for industry best practices that lead to superior performance", Milwaukee: ASQC Quality Press, P .12
- Commission of the European Communities (CEC), (1995), "Green Paper on Innovation", Office for Publications of the European Communities, Brussels
- Cooper, R. G. and Kleinschmidt, E. J., (1991), "New product process at leading industrial firms", *Industrial Marketing Management*, Vol. 20, pp. 137-47
- Cusimano, J.M., (1996), "Managers as facilitators", *Training & Development*, Vol. 50 No. 9, pp. 31-3
- Daniel V. Folkman and Kalyani Rai, (1997), "Reflections on facilitating a participatory community self-evaluation", *Evaluation and Program Planning*, Vol. 20, No. 4, pp. 455-465.
- De Jarnett, L. (1996), "Knowledge the latest thing", *Information Strategy, The Executives Journal*, Vol. 12, pt 2, pp. 3-5.
- Deming, W.E. (1986), *Out of Crisis*, MIT Press Cambridge, MA.
- Devlin, B., (1997), "Data warehouse: From architecture to implementation", Addison-Wesley, Reading, MA.
- Dixon, N., (1994), "The Organisational Learning Cycle: How We Can Learn Collectively", McGraw-Hill, London.
- Dixon, N., (1993), "Organisational Learning", Ottawa; Conference Board of Canada Report, pp. 111-93.
- Dodgson, M., (1993), "Organisational learning: A review of some literatures", *Organisation Studies*, 14(3), pp.375-394
- Drejer, A., (1996), "Integration of Business Strategy and Competence Development", Ph.D. Thesis, Department of Production, Aalborg University
- DTI and CBI, (1994), "Competitiveness - How the Best UK Companies Are Winning", Cm 2563, The Stationery Office, London
- Duncan, R. and Weiss, A., (1979), "Organisational learning: Implications for organisational design", *Research in Organisational Behaviour*, Vol. 1, pp. 75-123.

- Financial Times Mastering Management, (1997), "Introduction to Module 6",
Organisational Behaviour, FT Pitman Publishing
- Fiol, C.M. and Lyles, M.A., (1985), "Organisational learning", Academy of
Management Review, Vol. 10, pp. 803-13
- Fortune, (1993), "Quality '93: Empowering people with technology", September 20,
Advertisement Section.
- Garavan, T.N., (1991), "Strategic human resource development", Journal of European
Industry Training, Vol. 15 No. 1, pp. 17-31
- Garvin, D.A., (1988), "Managing Quality: The Strategic and Competitive Edge", The
Free Press, New York, NY.
- Garvin, D.A., (1993), "Building a learning organisation", Harvard Business Review,
71(July/August), pp. 78-91
- Gene Bellinger, (1997), "Knowledge Management", Notes from a Presentation at the
Knowledge Management Town Meeting at Documation, February, San Jose,
CA.
- Gephart, M.A., Marsick, V.J., Van Buren, M.E. and Spiro, M.S., (1996), "Learning
organisations come alive", Training & Development, Vol. 50 No. 12, pp. 34-46.
- Gershman, A., & Gottsman, E., (1993), "Hypermedia for corporate knowledge
dissemination", Proceedings of the twenty-sixth Hawaii International
Conference on System Sciences '93, CA: IEEE Press.
- Ghewamat, P., (1991), "Commitment: The Dynamic of Strategy", The Free Press, New
York, NY.
- Grubb L., (1998), "Using Total Cycle Time for Quick Response Manufacturing",
Assembly Automation, Vol. 18, No. 1, PP. 20-24.
- Guillermo Pérez-Bustamante, (1999), "Knowledge management in agile innovative
organisations", Journal of Knowledge Management, Vol. 3, No. 1, pp. 6-17
- Handy, C. (1995), "Trust and the virtual organisation", Harvard Business Review, Vol.
73 No. 3, May/June, pp. 40-50
- Hayes, R.H., Wheelwright, S.C. and Clark, K.B., (1988), "Dynamic Manufacturing",
Collier Macmillan, Basingstoke
- Hiltz, S. R. & Turoff, M., (1993), "The network nation: Human communication via
computer", MA: MIT Press.
- Hollingsworth D., (1994), "The workflow reference model", The Workflow
Management Coalition Document TC00-1003, November,
<http://www.aiim.org/wfmc/DOCS/refmodel/rmv1-16.html>

- Huber, G., (1991), "Organisational learning: the contributing processes and the literatures", *Organisation Science*, Vol. 2 No. 1, pp. 88-115.
- Hultink, E. J. and Robben, H. S. J., (1995), "Measuring new product success: the difference that time perspective makes", *Journal of Product & Innovation Management*, Vol. 12, No. 5, PP. 392-406.
- Iles, P., (1994), "Developing learning environments: challenges for theory, research and practice", *Journal of European Industrial Training*, Vol. 18 No. 3, pp. 3-9.
- Jay T. Knippen and Thad B. Green, (1997), "Problem solving", *Journal of Workplace Learning*, Vol. 9, No. 3, PP. 98-99.
- Johnson, G. and Scholes, K., (1993), "Exploring corporate strategy", 2nd edition, Prentice
- Kaplan, R. S. and Norton, D. P., (1993), "Putting the balanced scorecard to work", *Harvard Business Review*, Vol. 71, September /October, PP. 134-43.
- Kay, J., (1993), "Foundations of Corporate Success", Oxford University Press, Oxford
- Kenneth P., (1999), "Modelling of knowledge flows and their impact", *Journal of Knowledge Management*, Vol. 3, No. 1, PP. 36-46
- Kock Jr, N.F., McQueen, R.J. and Baker, M., (1996), "Learning and process improvement in knowledge organisations: a critical analysis of four contemporary myths", *The Learning Organisation*, Vol. 3 No. 1, pp. 31-41.
- Kotler, P., (1997), "Marketing Management-Analysis", Planning, Implementation and control, Prentice Hall, Upper Saddle River, NJ.
- Kuzma, A. T. and Shanklin, W. L., (1992), "How Medium-market-share Companies Achieve Superior Profitability", *Journal of Consumer Marketing*, Vol. 9, Winter, pp. 39-49.
- Lagasse, P., (1995), "Physician productivity measurement methodology and implementation", *Institute of Industrial Engineers, Quest for Quality and Productivity in Health Services Conference Proceedings*, pp. 108-16.
- Langemo, M., (1980), "Records management/word processing – a needed team effort", *Records Management Quarterly*, Vol. 14 No. 4, pp. 10-14.
- Levitt, B. and March, J.G., (1988), "Organisational learning", *Annual Review of Sociology*, Vol. 14, pp. 319-40
- Limerick, D., Passfield, R. and Cunnington, B., (1994), "Transformational change towards an action learning organisation", *The Learning Organisation*, Vol. 1 No. 2, pp. 29-40.

- Manuel Pedro, (1996), "Performance measurement in supply chains", 3rd international conference of the European operations management association, London 2-4 June, PP 45-50
- Mason, R. M., (1993), "Strategic information systems: Use of information technology in a learning organisation", Proceedings of the twenty-sixth Hawaii International Conference on System Sciences '93 S24, CA: IEEE Press, pp. 840-849.
- Masrick, V. J., (1994), "Trends in managerial reinvention: creating a learning map", Managerial Learning, Vol. 25 No. 1, pp. 11-34.
- McClelland, D.C., (1993), "The concept of competence", in Spencer, L.M. and Spencer, S.M., Competence at Work, John Wiley & Sons, New York, NY.
- McKee, D., (1992), "An organisational learning approach to product innovation", Journal of Product Innovation Management, Vol. 9, pp. 232-45
- McManus, K., (1996), "Acquiring knowledge and skills for twenty-first century supervision", Management Development Review, Vol. 8 No. 5, pp. 18-24
- McNair, C.J. and Leibfried, L., (1992), "Benchmarking: A Tool for Continuous Improvement, Harper Business, New York, NY.
- Morgan, G., (1997), "Images of Organisation", Sage Publications, Thousand Oaks, CA
- Morrison, J., (1993), "Team Memory: Information management for business teams", Proceedings of the twenty-sixth Hawaii International Conference on System Sciences '93, CA: IEEE Press, 122-131.
- Nadler, L. and Nadler, Z., (1994), "Designing Training Programs: The Critical Events Model", 2nd edition, Gulf Publishing Company, Houston, TX.
- Nevis, E. C., DiBella, A. J. and Gould, J. M., (1995), "Understanding organisations as learning systems", Sloan Management Review, Vol. 36 No. 2, pp. 73-85
- Nonaka, I., (1993), "The knowledge-creating company", in Howard, R. (Ed.), The Learning Imperative: Managing People for Continuous Innovation, Harvard Business School Press, Boston, MA.
- Nonaka, I. And Takeuchi, H., (1995), "The knowledge-Creating company", Oxford University Press, New York, NY, PP. 10-11
- Nonaka, I., (1994), "A dynamic theory of organisational knowledge creation", Organisational Science, Vol. 5 No. 1, pp. 14-37
- Oakland, J., (1993), "Total quality management - The route to improving performance", Butterworth- Heinemann.
- Pearn, M., Roderick, C. and Mulrooney, C., (1995), "Learning Organisations in Practice", McGraw-Hill, London

- Pedler, M., Boydell, T. and Burgoyne, J., (1989), "Towards the learning company", *Management Education and Development*, 20(1)
- Perrow, C., (1967), "A Framework for the Comparative analysis of Organisations", *American Sociological Review*, Vol. 32, p. 195
- Peters, J. and Smith, P., (1996), "Developing high-potential staff – an action learning approach", *The journal of Workplace Learning: Employee Counselling Today*, Vol. 8. No. 3, pp. 6-11.
- Plunkett, L. and Fournier, R., (1991), "Participative Management", John Wiley and Sons, New York, NY.
- Pugh, D. and Hickson, D., (1976), "Organisational Structure in its Context", *Aston Programme*, Vol. 1, Saxon House, Farnborough, UK.
- Pugh, D., Hickson, D. and Hinings, C., (1988), "Writers on Organisations", 3rd Ed., Penguin Books, Harmondsworth, Middlesex
- Prahalad, C.K. and Hamel, Gary, (1990), "The core competence of the corporation", *Harvard Business Review*, May-June, pp. 79-91
- Quigley, J., (1994), "Vision: how leaders develop it, share it and sustain it", *Business Horizons*, Vol. 37 No. 5, pp. 37-42.
- Quintas, P., Lefrere, P. and Jones, G., (1997), "Knowledge management: a strategic agenda", *Journal of Long Range Planning*, Vol. 30 No. 3, pp. 385-91.
- Raelin, J.A., (1997), "Action learning and action science: are they different?", *Organisational Dynamics*, Vol. 26 No. 1, pp. 21-34.
- Rogers, E.M. and Agarwala-Rogers, R., (1976), "Communication in Organisations", Collier Macmillan Publishers, The Free Press, London.
- Rogers, S., (1994), "Performance Management in Local Government", Longmans, Essex
- Robinson, T., Clemson, B. and Keating, C., (1997), "Development of high performance organisational learning units", *The Learning Organisation*, Vol. 4 No. 5, pp. 228-34
- Sandelands, E. (1998), "Creating an online library to support a virtual learning community", *Internet Research: Electronic Networking Applications and Policy*, Vol. 8 No. 1, pp. 75-80.
- Sanchez, Ron, Aime Heene and Howard Thomas, (1996), "Towards the theory and practice of competence-based competition", in *Dynamics of Competence-Based Competition: Theory and Practice in the New Strategic Management*, Ron Sanchez, Aime Heene and Howard Thomas, editors, Oxford: Elsevier.

- Schein, Edgar H., (1985), "Organisational culture and leadership: a dynamic view", Jossey-Based Publishers.
- Schein, E. H., (1988), "Process Consultation", Vol. 1, 2nd ed., Addison-Wesley, Reading, MA
- Schneider, B., (1987), "The people make the place", Personnel Psychology, Vol. 40, pp. 437-54.
- Schneider, B., Goldstein, H. W. and Smith, D. B., (1995), "The ASA framework: an update", Personnel Psychology, Vol. 48, pp. 747-73.
- Schrage, M., (1989), "Innovation and applied failure", Harvard Business Review, Vol. 67, November/December, pp. 42-7
- Senge, Peter, M., (1990), "The Fifth Discipline: The Art and Practice of the Learning Organisation". Doubleday New, York.
- Siegel, I. H., (1986), "Productivity Measurement in Organisations: Private Firms and Public Agencies", Pergamon Press, New York, NY, PP. 4-6
- Sinkula, James M., William Baker, and Thomas G. Noordewier, (1997), "A Framework for Market-Based Organisational Learning: Linking Values, Knowledge and Behaviour", Journal of the Academy of Marketing Science 25 (Fall): 305-318.
- Slater, S. F. and Narver, J. C., (1995), "Market information processing and organisational learning" Journal of Marketing, Vol. 59, July, pp. 63-74.
- Smith, P.A.C., (1997), "Q'ing action learning: more on minding our Ps and Qs", Management Decision, Vol. 35 No. 5, pp. 365-72.
- Stata, R., (1989), "Organisational learning - The key to management of innovation", Sloan Management Review, 30(3), 63- 74.
- Suzaki, K., (1987), "The New Manufacturing Challenge", The Free Press, New York, NY
- Swieringa, J. and Wierdsma, A., (1992), "Becoming a Learning Organisation: Beyond the Learning Curve", Addison-Wesley, London.
- Tjepkema, S. and Scheerens, J., (1998), "Role of HRD in learning organisations—European concepts and practices", University of Twente, The Netherlands
- University of Warwick, (1999), "Knowledge management", Business Processes Resource Centre, University of Warwick. URL:<http://bprc.warwick.ac.uk/Kmweb.html> (site visited at: 2 February 1999) This site also provides useful links to further "Knowledge Management" sites.
- Utterback, J. M., (1994), "Mastering the Dynamics of Innovation", Harvard Business School Press, Boston, MA.

- Vavra, T.G., (1997), "Improving Your Measurement of Customer Satisfaction: A Guide to Creating, Conducting", Analysing, and Reporting Customer Satisfaction Measurement Programs, ASQ Quality Press.
- Walsh, J.P. and Ungson, G.R. (1991), "Organisational memory", *Academy of Management Review*, Vol. 16 No. 1, pp. 57-91.
- Walters, M., (1995a), "Developing organisational analysis", Chapter 2, in Walters, M. (Ed.), *The Performance Management Handbook*, Institute of Personnel and Development, London.
- Walters, M. (Ed.), (1995b), "The Performance Management Handbook", Institute of Personnel and Development, London
- Watkins, K. and Marsick, V., (1993), "Sculpting the Learning Organisation", Jossey-Bass, San Francisco, CA.
- Weick, K.E. and Daft, R., (1984), "The effectiveness of interpretation systems", in Cameron, K.S. and Whetten, D.A. (Eds), *Organisational Effectiveness: A Comparison of Multiple Models*, Academic Press, Orlando, FL, pp. 70-93.
- Worrll, D., (1995), "The learning organisation: management theory for the information age or new age fad?", *Journal of Academic Librarianship*, Vol. 21, No. 5, pp. 351-8.
- WTO, (1985), "Identification and Evaluation of those Components of Tourism Services which have a Bearing on Tourist Satisfaction and which can be Regulated and State Measures to Ensure Adequate Quality of Tourism Services", World Tourism Organisation, Madrid.
- Zairi, M., (1994), "Measuring Performance for Business Results", Chapman & Hall, London

APPENDIX 5.1

THE COVERING LETTER

Organisational practice and organisational performance

<Date>

Dear <Title> <Name>

I am sure you are a very busy person because you hold a very important position in your organisation. I am a PhD research student at Sheffield Hallam University, UK, currently doing a questionnaire survey on organisational practice and organisational performance. The present survey is an integral part of my research, which will help me to obtain required information in order to develop a learning organisation and to examine the relationships between total quality management and organisational learning to improve the organisational performance.

Your organisation has been selected from the CBI-UK Kompass source. You could significantly contribute to the research by participating in the survey. Consequently, I would be most grateful if you could spare a little of your time to complete the enclosed questionnaire and returning it as soon as you can. Please use the provided pre-paid envelope.

If you have any questions at all, please don't hesitate to contact me. I respect the confidentiality of information you provide and therefore give assurance of anonymity in the research report. Please, cross the box at the end of questionnaire if you wish to have a summary of findings. Thank you for your co-operation.

Hamdy Abdelmeguid

Sheffield Hallam University
School of Engineering
City Campus
Howard Street
Sheffield, S1 1WB
UK

Tel: 0114-2253091
Fax: 0114-2253433
E-mail: H.Abdelmeguid@shu.ac.uk

The revised covering letter

Organisational practice and organisational performance

<Date>

Dear <Title> <Name>

I would like to remind you of a request for your participation in a recent survey on developing a learning organisation. As of this time, I am afraid I have not received your organisation's completed questionnaire. Data from your organisation is very important to be included in this study to develop a learning organisation to improve the organisational performance. In case your organisation does not implement one of the continuous improvement programmes, which are presented in section 3, I would be very grateful if you could write no in the space provide.

I would be extremely grateful if you could spend a few minutes of your time to complete the questionnaire and return it to me when you can by surface mail using the pre-paid provided envelop. Please, let me know if you need another copy of the questionnaire so that I could provide you with one.

Your time and interest are sincerely appreciated. Please ignore this letter if you have already responded to the questionnaire.

Thank you.

Yours sincerely,

Hamdy Abdelmeguid
Sheffield Hallam University
School of Engineering
City Campus
Howard Street
Sheffield, S1 1WB
UK
Tel: 0114-2253091
Fax: 0114-2253433
E-mail: H.Abdelmeguid@shu.ac.uk

Organisational practice and organisational performance

Questionnaire

Introduction

Organisational practice and organisational performance

PLEASE READ THIS BEFORE YOU FILL IN THE QUESTIONNAIRE

The aim of the survey is to examine the strength of the relationship between organisational practice and organisational performance.

- The research is for educational purposes only and is not a commercial activity
- All individual and company data will be treated in confidential
- Please indicate if you wish to receive a copy of the final analysis

Hamdy Abdelmeguid
Sheffield Hallam University
School of Engineering
City Campus
Howard Street
Sheffield
S1 1WB
UK
Tel: 0114-2253091
Fax: 0114-2253433
E-mail: H.Abdelmeguid@shu.ac.uk

➤ **Indicate the following characteristics for your organisation.**

	Not Applicable N/A	No progress 0 %	Some progress 25 %	Satisfactory 50 %	Good progress 75 %	Achieved 100 %
• The organisation is continuously evaluating the work processes against an industry leader.	<input type="checkbox"/>	<input type="checkbox"/>	<input type="checkbox"/>	<input type="checkbox"/>	<input type="checkbox"/>	<input type="checkbox"/>
• The employee know how to learn from mistakes	<input type="checkbox"/>	<input type="checkbox"/>	<input type="checkbox"/>	<input type="checkbox"/>	<input type="checkbox"/>	<input type="checkbox"/>
• The organisation is continuously introducing advanced technologies	<input type="checkbox"/>	<input type="checkbox"/>	<input type="checkbox"/>	<input type="checkbox"/>	<input type="checkbox"/>	<input type="checkbox"/>
• Individuals and teams have an easy access to the information relevant to their area of responsibility.	<input type="checkbox"/>	<input type="checkbox"/>	<input type="checkbox"/>	<input type="checkbox"/>	<input type="checkbox"/>	<input type="checkbox"/>
• A data collection mechanism for decision-making and problem solving is in place.	<input type="checkbox"/>	<input type="checkbox"/>	<input type="checkbox"/>	<input type="checkbox"/>	<input type="checkbox"/>	<input type="checkbox"/>
• The organisation understands the process by which individuals/teams learn.	<input type="checkbox"/>	<input type="checkbox"/>	<input type="checkbox"/>	<input type="checkbox"/>	<input type="checkbox"/>	<input type="checkbox"/>
• The organisation has developed a model to facilitate learning process.	<input type="checkbox"/>	<input type="checkbox"/>	<input type="checkbox"/>	<input type="checkbox"/>	<input type="checkbox"/>	<input type="checkbox"/>

Any other:

.....

➤ **Do the following factors support organisational process in your organisation?**

	Not Applicable	Disagree	Slightly Agree	Agree	Strongly Agree	Very Strongly agree
	N/A	0 %	25 %	50 %	75 %	100%
• Culture	<input type="checkbox"/>	<input type="checkbox"/>	<input type="checkbox"/>	<input type="checkbox"/>	<input type="checkbox"/>	<input type="checkbox"/>
• Rewards/recognition	<input type="checkbox"/>	<input type="checkbox"/>	<input type="checkbox"/>	<input type="checkbox"/>	<input type="checkbox"/>	<input type="checkbox"/>
• Leadership	<input type="checkbox"/>	<input type="checkbox"/>	<input type="checkbox"/>	<input type="checkbox"/>	<input type="checkbox"/>	<input type="checkbox"/>
• Organisation structure	<input type="checkbox"/>	<input type="checkbox"/>	<input type="checkbox"/>	<input type="checkbox"/>	<input type="checkbox"/>	<input type="checkbox"/>
• Information system	<input type="checkbox"/>	<input type="checkbox"/>	<input type="checkbox"/>	<input type="checkbox"/>	<input type="checkbox"/>	<input type="checkbox"/>
• Communication	<input type="checkbox"/>	<input type="checkbox"/>	<input type="checkbox"/>	<input type="checkbox"/>	<input type="checkbox"/>	<input type="checkbox"/>
• Empowerment	<input type="checkbox"/>	<input type="checkbox"/>	<input type="checkbox"/>	<input type="checkbox"/>	<input type="checkbox"/>	<input type="checkbox"/>
• Management responsibility	<input type="checkbox"/>	<input type="checkbox"/>	<input type="checkbox"/>	<input type="checkbox"/>	<input type="checkbox"/>	<input type="checkbox"/>
• Individual/team development	<input type="checkbox"/>	<input type="checkbox"/>	<input type="checkbox"/>	<input type="checkbox"/>	<input type="checkbox"/>	<input type="checkbox"/>
• Performance management	<input type="checkbox"/>	<input type="checkbox"/>	<input type="checkbox"/>	<input type="checkbox"/>	<input type="checkbox"/>	<input type="checkbox"/>
• Continuous improvement	<input type="checkbox"/>	<input type="checkbox"/>	<input type="checkbox"/>	<input type="checkbox"/>	<input type="checkbox"/>	<input type="checkbox"/>
• Shared vision/strategy	<input type="checkbox"/>	<input type="checkbox"/>	<input type="checkbox"/>	<input type="checkbox"/>	<input type="checkbox"/>	<input type="checkbox"/>

Any other:

.....

➤ **Does your organisation implement one or more of the following continuous improvement/learning process/advanced technology programmes:**

- | | | |
|---|--|---|
| 1. TQM
<input type="checkbox"/> | 2. Organisational learning
<input type="checkbox"/> | 3. BPR
<input type="checkbox"/> |
| 4. Knowledge management
<input type="checkbox"/> | 5. Supply chain management
<input type="checkbox"/> | 6. Information Technology
<input type="checkbox"/> |

Any other:

.....

➤ **When did your organisation implement the continuous improvement/learning process/advanced technology programmes?**

- | | | | |
|--|---|---|---|
| 10 years ago
<input type="checkbox"/> | 5 years ago
<input type="checkbox"/> | 3 years ago
<input type="checkbox"/> | less than 3 years
<input type="checkbox"/> |
|--|---|---|---|

➤ **Please indicate the effect of your continuous improvement/learning process/advanced technology activities on the following performance measure:**

	Not Applicable N/A	Gone Worse 0 %	No change 25 %	Improved 50 %	Improved between 75 %	Substantially improved 100 %
• Customer satisfaction	<input type="checkbox"/>	<input type="checkbox"/>	<input type="checkbox"/>	<input type="checkbox"/>	<input type="checkbox"/>	<input type="checkbox"/>
• Delivery reliability	<input type="checkbox"/>	<input type="checkbox"/>	<input type="checkbox"/>	<input type="checkbox"/>	<input type="checkbox"/>	<input type="checkbox"/>
• Order cycle time (time from receipt of order to delivery to customer)	<input type="checkbox"/>	<input type="checkbox"/>	<input type="checkbox"/>	<input type="checkbox"/>	<input type="checkbox"/>	<input type="checkbox"/>
• Inventory turnover	<input type="checkbox"/>	<input type="checkbox"/>	<input type="checkbox"/>	<input type="checkbox"/>	<input type="checkbox"/>	<input type="checkbox"/>
• Productivity	<input type="checkbox"/>	<input type="checkbox"/>	<input type="checkbox"/>	<input type="checkbox"/>	<input type="checkbox"/>	<input type="checkbox"/>

	Not Applicable N/A	Gone Worse 0 %	No change 25 %	Improved 50 %	Improved between 75 %	Substantially improved 100 %
• Employee productivity	<input type="checkbox"/>	<input type="checkbox"/>	<input type="checkbox"/>	<input type="checkbox"/>	<input type="checkbox"/>	<input type="checkbox"/>
• Market share	<input type="checkbox"/>	<input type="checkbox"/>	<input type="checkbox"/>	<input type="checkbox"/>	<input type="checkbox"/>	<input type="checkbox"/>
• Information sharing process	<input type="checkbox"/>	<input type="checkbox"/>	<input type="checkbox"/>	<input type="checkbox"/>	<input type="checkbox"/>	<input type="checkbox"/>
• Defect rates	<input type="checkbox"/>	<input type="checkbox"/>	<input type="checkbox"/>	<input type="checkbox"/>	<input type="checkbox"/>	<input type="checkbox"/>
• Innovation (new products)	<input type="checkbox"/>	<input type="checkbox"/>	<input type="checkbox"/>	<input type="checkbox"/>	<input type="checkbox"/>	<input type="checkbox"/>
• Workflow improvement	<input type="checkbox"/>	<input type="checkbox"/>	<input type="checkbox"/>	<input type="checkbox"/>	<input type="checkbox"/>	<input type="checkbox"/>
• Individual competence development	<input type="checkbox"/>	<input type="checkbox"/>	<input type="checkbox"/>	<input type="checkbox"/>	<input type="checkbox"/>	<input type="checkbox"/>
• Knowledge collection / acquisition capability	<input type="checkbox"/>	<input type="checkbox"/>	<input type="checkbox"/>	<input type="checkbox"/>	<input type="checkbox"/>	<input type="checkbox"/>
• Knowledge storing capability	<input type="checkbox"/>	<input type="checkbox"/>	<input type="checkbox"/>	<input type="checkbox"/>	<input type="checkbox"/>	<input type="checkbox"/>
• Knowledge processing / analysis capability	<input type="checkbox"/>	<input type="checkbox"/>	<input type="checkbox"/>	<input type="checkbox"/>	<input type="checkbox"/>	<input type="checkbox"/>
• Knowledge retrieving capability.	<input type="checkbox"/>	<input type="checkbox"/>	<input type="checkbox"/>	<input type="checkbox"/>	<input type="checkbox"/>	<input type="checkbox"/>

Any other:

.....

Section 4	GENERAL INFORMATION
-----------	---------------------

➤ **Please provide the following information about you and your company.**

Your name: Tel:

Your position in the organisation:

Organisation name and address:

.....

.....

Number of employees at your organisation	Under 100	100-200	201-500	501-1000	Over 1000
	<input type="checkbox"/>	<input type="checkbox"/>	<input type="checkbox"/>	<input type="checkbox"/>	<input type="checkbox"/>
Estimated sales for the last financial year (£ m / year)	Under 5		5-50	50-500	Over 500
	<input type="checkbox"/>		<input type="checkbox"/>	<input type="checkbox"/>	<input type="checkbox"/>
				Yes	No
Would you like to participate in a second survey to this study?				<input type="checkbox"/>	<input type="checkbox"/>
Would you be interested in to receive a copy of the final analysis?				<input type="checkbox"/>	<input type="checkbox"/>

Thank you for taking time to complete this questionnaire

APPENDIX 5.2

SURVEY ANALYSIS OF THE TEN ORGANISATION

As reported in Chapter 5 the initial analysis of the questionnaires revealed that ten out of the thirty-six returned questionnaires were either not completed or had some contradicted information, therefore they were excluded from the analysis. As shown in Tables 5.2.1 and 5.2.2 organisations numbers two, four and eight are partially completed, while organisations one and three have some conflict information between the enablers and the results ratings. On the other hand, the average values of T, O, and P for the organisations five, six, seven, nine, and ten are not consistent with the role of categorise the organisations under the three waves of quality. For example, the average values of T, O, and P for the organisation seven are 0.1875, 0.40625 and 0.70833 respectively. According to the T, O, and P role, which is discussed in Chapter 5, it is difficult to identify the organisation wave (first, second or third wave) because the T value is in the first wave, the O value is in the second wave and the P value is in the third wave.

		Organisation number															
		1	2	3	4	5	6	7	8	9	10						
Enablers	Technologies	Learning loops/process	0.5	0.5	0.25	0	0.25	0	0.25	0	0.25	0	0.25	0	0.25	0.25	
		Problem solving	0.25	0.5	0.25	0	0	0.25	0	0.25	0	0.25	0	0.25	0	0.5	0.25
		Benchmarking	0.25	0.5	0.25	0	0.25	0.25	0	0.25	0.25	0.25	0	0.25	0	0.75	0.25
		Action learning	0.25	0.25	0.5	1	0.25	0	0.25	0	0.25	0	0.25	0	0.5	0.5	0.25
		Continuous improvement	0.5	0	0	0.25	0.25	0	0	0	0.25	0	0	0	0.75	0	0
		Learning cycle	0.25	----	0.5	0	0	0.25	0	0.25	0	0.25	0	0.25	0.25	0.25	0.5
		Learning orientation	0.75	----	0.25	0	0.25	0	0.25	0	0.25	0	0.5	0	0.5	0.25	0.25
		Information system	0.75	----	0.5	0.25	0.5	0	0.25	0	0.5	0	0	0	0.75	0.75	0
		Technology elements average value	0.4375	0.35	0.3125	0.1875	0.21875	0.09375	0.1875	0.1875	0.041667	0.53125	0.53125	0.21875	0.21875	0.21875	0.21875
		Organisation	Culture	0.25	0	0	0	1	0	0.5	0	1	1	0.5	0	0	0
Organisation structure	0.25		0	0.25	1	1	1	0.75	0.5	0.75	0	0.75	0	0.75	0	0.25	
Communication	0.75		0.25	0.25	----	1	0.5	0.25	0.25	0.75	0.25	0.25	0.75	0.25	0.25	0.5	
Shared vision/learning Strategy	0.5		0.5	0.5	----	0.25	1	0.25	0	0.25	1	0.25	0	0	0	0.75	
Performance management	0.75		----	0	----	0.75	1	0.75	0	0.75	1	0.75	----	0	0	0.5	
Fostering new ways of thinking	0.5		----	0.25	0	0.5	0.75	0.25	0.25	0.25	0.75	0.25	0.25	0.25	0.25	0.25	
Potential behaviour	0.75		----	0.25	0	0.5	1	0.5	1	0.5	1	0.5	----	0.5	0.5	1	
Learning communities	0.5		0.25	0.25	----	1	1	0.25	1	0.25	1	0.25	1	0.5	0.5	1	
Organisations elements Average value	0.53125		0.2	0.21875	0.25	0.75	0.875	0.40625	0.40625	0.5	0.1875	0.59375	0.59375	0.59375	0.59375	0.59375	
People	Leadership		0.75	----	0.25	0	1	0.75	0.75	0.75	0.75	0.75	0.75	0.75	0.75	0.75	0.25
	Management responsibility	0.75	----	0.5	----	1	0	0.75	0	0.75	0	0.75	0	0.25	0.25	1	
	Empowerment	0.25	----	0.25	----	0.75	0	0	1	0	0	1	----	0	0	1	
	Rewards/recognition	0.5	0.25	0.25	----	0.5	0	0.5	0	0.5	0	0.5	0	0	0	0.5	
	Team learning	0.5	0.25	0.25	0	1	0	0	0.5	0	0	0.5	0	0	0	0.75	
	Training and education	0.25	0.25	0.25	0	0.75	0	0.75	0	0.75	0	0.75	0	0	0	1	
	Average value of people	0.5	0.25	0.291667	0	0.833333	0.125	0.708333	0.708333	0	0.125	0.125	0.125	0	0.125	0.75	

Table 5.2.1: The values of enablers for the ten organisations

Results	Organisation number									
	1	2	3	4	5	6	7	8	9	10
Financial performance	0	---	1	---	0.25	0.75	0.25	0	0.5	0
Inventory turnover	0	---	1	---	0.25	0.75	0.25	0	0.5	0
Productivity	0	1	1	---	0.25	0.75	0.25	0	0.5	0
Employee productivity	0	0.75	1	---	0.5	0.5	0.5	0.75	0.25	0
Market share	0	0	1	0	0.25	0.75	0.25	0	0.5	0
Reduce defect rates	0	0	1	0.25	0.25	0.5	0.25	0	0	0.25
Financial performance average value	0	0.4375	1	0.125	0.3	0.65	0.3	0.15	0.35	0.05
Customer satisfaction	0	0.75	1	0.25	0.25	0.5	0.25	---	0.5	0.5
Delivery reliability	0	---	1	---	0.25	0.25	0.25	---	0.25	0.75
Order cycle time	0	---	1	0	0.5	0.5	0.5	---	0.5	0
Innovation (new products)	0	---	1	0	0.25	0.75	0.25	---	0.5	0
Workflow improvement	0	0	1	0	0.25	0.5	0.25	---	0.5	0.5
Knowledge acquisition capability	0	0	1	---	0.25	0.5	0.25	---	0.25	0.25
Knowledge storing capability	0	---	1	---	0.25	0.75	0.25	0.25	0.25	0.5
Knowledge processing	0	---	1	0.75	0.25	0.5	0.5	0	0.25	0.25
Knowledge retrieving capability	0	1	1	---	0.25	0.25	0.25	0	0.5	0.25
Information sharing process	0	0	1	0	0.25	0.75	0.25	---	0.5	0.25
Individual competence development	0	---	1	0.25	0.25	0.25	0.25	---	0.5	0.25
Non-financial performance average value	0	0.35	1	0.178	0.272	0.5	0.295	0.083	0.409	0.318

Table 5.2.2: The values of organisational performance (results) for the ten organisation

APPENDIX 6.1

CAUSAL-LOOP DIAGRAMS

The methodology is a synthesis of several disciplines, the philosophy of systems thinking, the principle of feedback dynamics, and the experimental methodology of computer simulation. A feedback exists whenever there is a two-way causal relationship between variable. A change initiated by variable X causes Y to change, which in turn causes Z to change, which finally closes the loop by influencing X. There are two types of feedback loops. A balancing or negative loop represent the case where a change initiated by X propagates through the loop and returns to X in a way to counter the direction of initial change in X. A reinforcing or positive loop on the other hand reinforces the change initiated by one of its variables. Typically, reinforcing loops generate growth patterns over time. When many balancing and reinforcing loops act and interact simultaneously over time, they create the dynamic behaviour patterns of the system. To better understand the system structure the diagram shown in Figure 6.1.1 illustrates the graphical notation for representing the influence diagram.

Figure 6.1.1 defines notation for the causal-loop / influence diagram. This diagram is an annotated causal-loop diagram for a simple inventory based production system. This diagram includes elements and arrows (which are called causal links) linking these elements together. It also includes a sign (either + or -) on each link. These signs have the following meanings: -

- A causal link from one element A to another element B is positive (that is, +) if either A adds to B or a change in A produces a change in B in the same direction.
- A causal link from one element A to another element B is negative (that is, -) if either A subtracts from B or a change in A produces a change in B in the opposite direction.

The causal-loop diagram shown in Figure 6.1.1 illustrates this notation. For example, if the “demand production rate” is increased then the “Rate at which orders are completed” increases. Therefore, the sign on the link from demand production rate to COMRATE is positive. Another example, the “inventory error” element is the

difference between the “desired inventory” and “actual inventory level”. From this definition, it follows that an increase in AINV decrease EINV, and therefore the sign on the link between these two elements is negative.

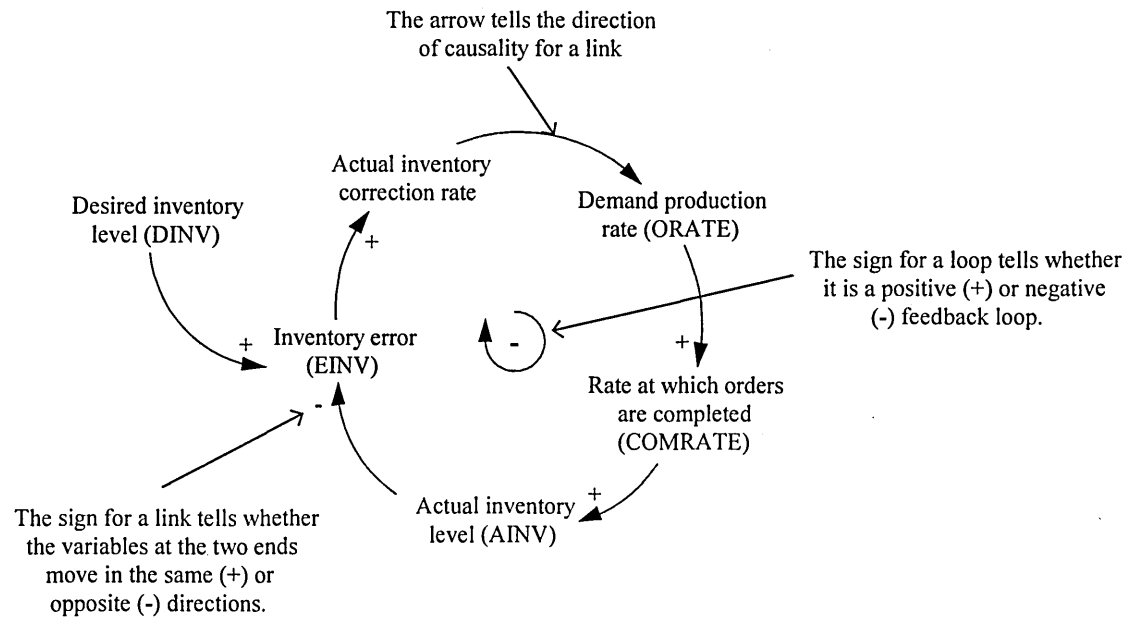

Figure 6.1.1:Causal-loop diagram notation

In addition to the signs on each link, a complete loop also is given a sign. The sign for a particular loop is determined by counting the number of minus (-) signs on all the links that make up the loop. Specifically,

- A feedback loop is called [positive, indicated by a + sign in parentheses, if it contains an even number of negative causal links.
- A feedback loop is called negative, indicated by a – sign in parentheses, if it contains an odd number of negative causal links.

Thus, the sign of a loop is the algebraic product of the signs of its links. Often a small looping arrow is drawn around the feedback loop sign to more clearly indicate that the sign refers to the loop, as is done in Figure 6.1.1. Note that in this diagram there is a single feedback (causal) loop, and that this loop has one negative sign on its links. Since one is an odd number, the entire loop is negative.

- **Stock-flow diagrams**

Stock-flow diagram are composed of four different components: stocks, flows, converter, and connectors. The labels shown in Figure 6.1.2 may vary slightly in

different arenas. These labels were taken from the *ithink* software documentation. There are several conventions for stock-flow diagrams: -

- Flows can influence stocks
- Stocks can influence flow or converters
- Converters can influence flows or other converters
- Flows cannot influence converters or other flows
- Converters cannot influence stocks
- Stocks cannot influence other stocks.

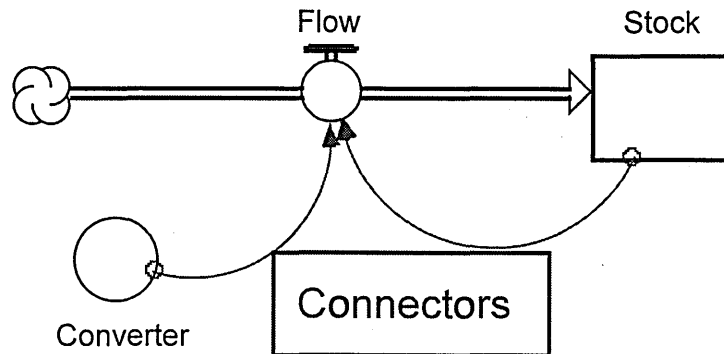

Figure 6.1.2: Stock-flow diagram

The language of system dynamics is simple (Figure 6.1.2). Stocks (also called Levels) contain quantities describing the state of the system. If the model (or system) were stopped, each of these would continue to hold its quantity for observation. For example, the amounts of money in various financial accounts are typically levels in a financial system. In a typical system dynamics diagram, these appear as labelled rectangles.

Flows (also called Rates) are the inflows to and outflows from the various levels. These appear as labelled valves on pipes connecting levels. If the system were stopped, rates also stop. For example, the paying of interest into an account is a rate. If the system were frozen in time, there would be no flow of interest into accounts.

Connectors and converters (also called auxiliaries) measure the quantities in levels and, through various calculations, control the rates. These appear as lines with arrows and as circles. Management policies (the rules by which managers make decisions) are modelled by these calculations.

- **System dynamics equations**

The equations for the model shown in Figure 6.1.2 are: -

Stock:

$$\text{Stock (t)} = \text{Stock (t - dt)} + \text{Flow} * \text{dt}$$

Document: This is the stock of the system. It corresponds to the bank balance, the stock of knowledge, the population and inventory in the example above.

UNIT: units

Converter:

There are two types of converters

1. If the converter is the compounding fraction or growth factor. The equations for the flow and compounding fraction are: -

Inflows:

$$\text{Flow} = \text{Stock} * \text{Converter}$$

Document: The flow is the fraction of the stock that flows into the system per unit time. It corresponds to the interest earned, the learning, and the birth.

UNIT: units/time

Compounding fraction = a constant

Document: This is the compounding fraction or growth factor. It determines the inflow to the stock. The compounding fraction corresponds to the interest rate and birth fraction. It is the amount of units added to the stock for every unit already in the stock, every time.

UNITS: units/unit/ time

2. If the converter is a time constant the equation for the flow and time constant would be: -

Inflows:

$$\text{Flow} = \text{Stock} / \text{time constant}$$

UNITS: units / time

Time constant = a constant

Document: This is the time constant. It is adjustment time for the stock. It corresponds to the time to learn and production time in the above example. This is the time for each initial unit to compound into a new unit.

UNITS: time

- **Block diagram**

The first step towards the model building is to transform the conceptual model into a block diagram. A block diagram representation of Inventory Order Based Production Control System (IOBPCS) is given in Figure 6.1.3. In this format, the flows of information and materials are represented via various paths. Production, ordering and other physical/administrative operations are represented using blocks. The block diagram describes how the system works and which shows the exact relationship between variables by including a mathematical notation. It's very common in control theory and it is very applicable when describing production and inventory problems. The block diagram aids in formulating mathematical and simulation models.

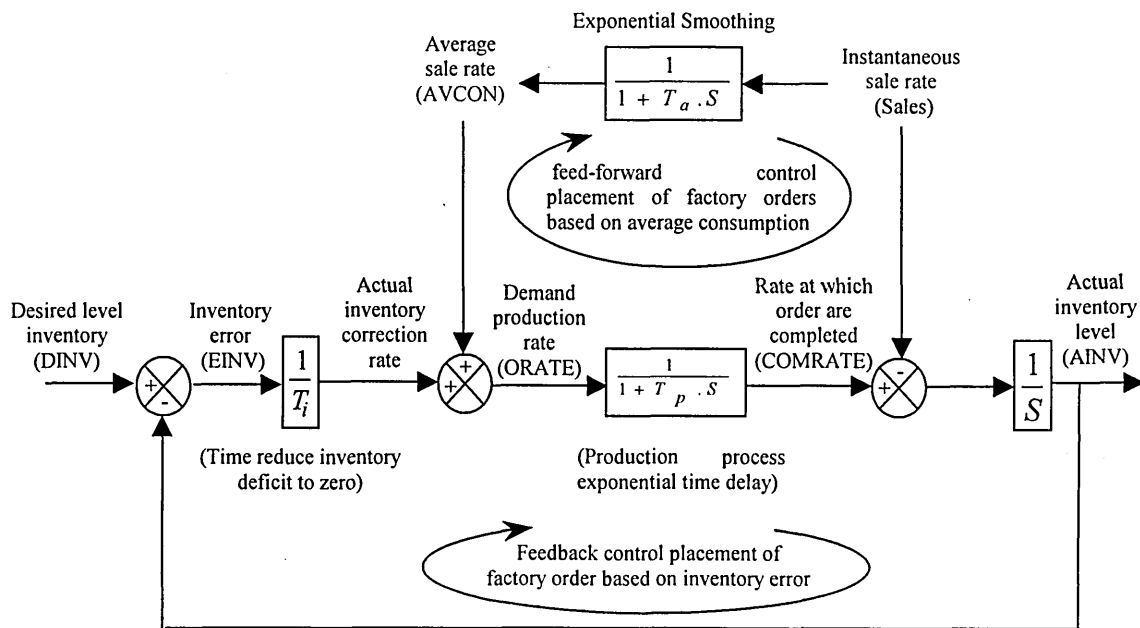

Figure 6.1.3: Block diagram of IOBPCS

APPENDIX 6.2

A GENERIC FAMILY OF IOBPCS

Nomenclature:

DINV:	Desired inventory.
AINV:	Actual inventory.
EINV:	Error inventory.
CINV:	Change in inventory.
SALES/CONS:	Sales or consumption.
ORATE:	Order rate placed on pipeline.
AVCON:	Average sales or consumption.
COMRATE:	Completion rate.
T_i	Time to recover the stock deficit.
T_p	The factory pipeline lead-time.
T_a	The demand averaging time.

Levels:

AINV: It is a level of an actual inventory that an organisation to store and it refers to acquired stocks. It considers that the units of the actual inventory are widgets.

WIP: It is a state to refer a process production. It considers that the units of the work in process are widgets.

Rates:

ORATE: It is a demanded production rate and it refers to process order. Widgets/weeks are the units of order rate placed on pipeline.

COMRATE: It is a rate at which orders are completed and it refers to process acquisition rate. Widgets/weeks are units of completion rate.

SALES/CONS: It is a rate of sales or consumption and it refers to present loss rate. The units of sales/consumption are widgets/weeks.

AVCON: It is an average sales/consumption rate and it refers forecast expected loss rate. The units of average consumption/sale are widgets /weeks.

Constants:

DINV: It is a level of a desired inventory so it is a target. It refers to desired stocks levels. The units of desired inventory are widgets.

T_i : It is the time to adjust inventory and it is proportional of inventory error that is feedback. It is important because adjustment order for supply chains effects. The units of time to adjust inventory are weeks.

T_p : It is the actual pipeline lead-time and it refers to a process acquisition lag. Weeks are the units of actual pipeline lead-time.

T_a : It is the time to average consumption/sales. It refers to exponential smoothing parameters used when forecasting expected loss rate. The units of time to average consumption are weeks.

Benchmarking a generic family of IOBPCS.

A manufacturing ordering and control system's operation can be viewed in some conceptual terms. These conceptual terms are the interaction between the system and its environment as well as between the sub-systems of which it is comprised (Patching, 1990). Such systems operate within the environment of a market from which it hopes to gain customer orders. In turn it aim to respond with products that have been generated as a result of information flow between sales forecasting, stores and production capabilities. This simple model is shown in Figure 6.2.1.

The models of different ordering and control structures were assembled into a generic progression from the simplest viable structure. This created the nucleus of family, which could be compared via analysis and simulation (Edghill, 1990). The generic development ensured that the increasing complexity in the ordering and control algorithms considered would be judged in terms of the change in performance from a simpler model. The manufacturing models considered herein cover the following strategic consideration: -

- Whether to fix or vary desired inventory levels as a function of demand (IOBPCS; VIOBPCS1 And 2)
- The consequences of utilising information on real-time shop-floor production performance in the algorithm to modify factory orders (CPIOBPCS)
- The relative merits of allowing for production lead-times by incorporating a despatch delay (DIOBPCS).

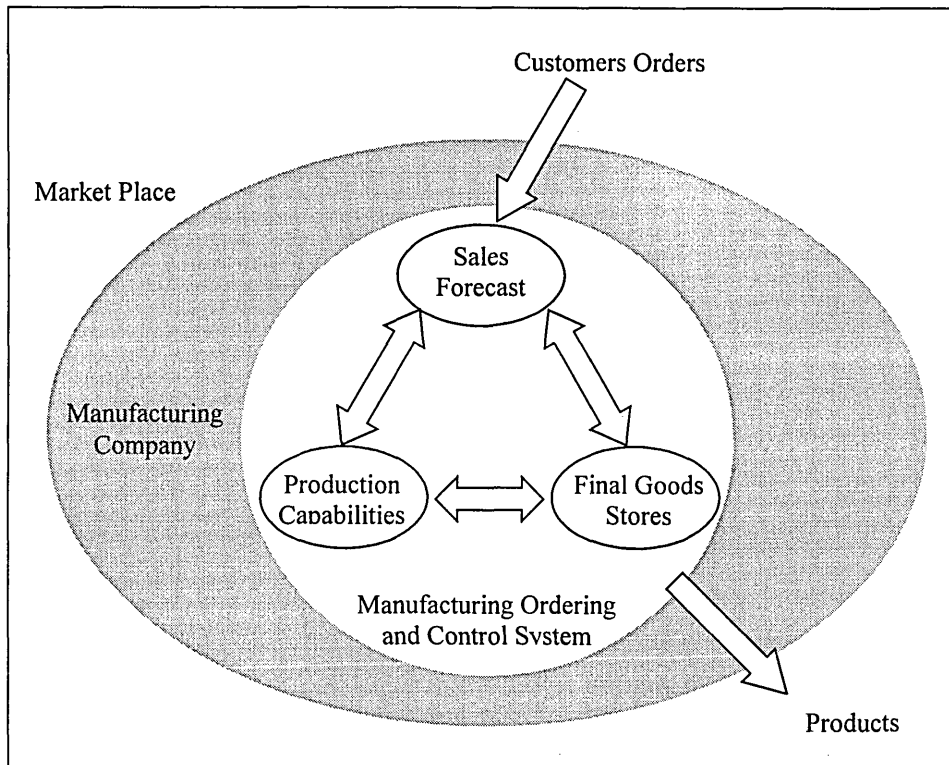

Figure 6.2.1: Initial soft system model of an inventory and order based manufacturing control system (Ferris, 1993).

The additional complexity for each of the above options comes from the [presence of additional feedback and feed-forward paths. Table 6.2.1 gives the strategic development between different family members using IOBPCS as a baseline.

The family of manufacturing ordering and control models studied are variants of the IOBPCS structure. The variations used to date are summarised in Figure 6.2.2 and relate to the strategies listed in Table 6.2.1. The first pair of variants form the IOBPCS considers freeing inventory levels from a predefined constant value. This is represented by the Variable Inventory and Orders based Production Systems (VIOBPCS1 and VIOBPCS2). These differ from IOBPCS in only one respect: the desired inventory level varies as a multiple (K) of the estimated weekly sales/consumption. Thus should sales fall, so too will the target stock levels and the reverse will happen if the market is buoyant. This is shown in Figure 6.2.2 where path b is used in the calculation of the inventory deficit contribution to the order rate scheduled ($T_b = T_a$) rather than the constant input DINV.

Generic family members	Development strategy for the structure's design	Assumptions that might be problematic in practice
IOBPCS	The simplest effective structure considered, without counter intuitive steady state offsets.	Ensuring the accuracy of the stock levels.
CpIOBPCS	Adding an extra control path around the shop floor to decrease the effective production lead-time.	Ensuring that the shop floor performance information used in scheduling decisions is accurate.
VIOBPCS1	Extending the feed-forward path to vary target stock levels in line with market demand.	
VIOBPCS2	Adding an extra feed-forward path to vary stocks levels in line with market demand.	
DIOBPCS	Allowing for a delivery delay as part of marketing policy.	Ensuring that the estimation of production lead-time used to set the delivery delay is accurate.

Table 6.2.1: The proposed generic family of manufacturing system structural designs, given in terms of both their strategic design and their practical assumptions (Ferris, 1993).

In VIOBPCS2 any variation in the desired stock is restrained by heavier smoothing in path b, whilst path a is used with smoothing on it deliberately chosen to be of a shorter duration ($T_b > T_a$). This lighter, direct contribution to the order rate ensures that the production ordering is responsive to changes in sales, whilst changes in stock holdings more cautious.

In the conditional feedback Inventory Order Based Production Control System includes current production performance levels and it is represented by the conditional feedback. This structure differs from the IOBPCS in one respect: the added consideration of shop floor performance in the order rate calculation shown in Figure 6.2.2 via path d. This additional path speeds up the system response provided there is the ability to constantly "fine tune" plant leading available. It compares the production currently completed with the sum of the current inventory error and sales rate estimates that form the IOBPCS style current production order rate. CpIOBPCS then further adjusts the order rate proportional to the difference between the two signals. In this model, it is included here in a simple form with only the proportional control law used and the process model being assumed to be unity.

The final scheduling strategy represented is that of scheduling within a despatch delayed, Delivery Inventory and Order Based Production Control System (DIOBPCS). This again builds from a basis of the IOBPCS with the targeted constant inventory (DINV) set to zero. The strategy modelled is to include a despatch delay allowance to the customer, which allows for production time and negates the need for stock.

Table 6.2.2 summarises which feed-forward and feedback paths are included in the different model structures. It also quotes the parameters included in each model. Showing those values that were treated as constants in this study and those, which were varied. The values of the parameters are normalised by being quoted as multiples of T_p , i.e. the delay time in the function modelling the production process and manufacturing lead-time.

Family member	Information paths (w.r.t. Fig. 2)				System parameters							
	Feed-forward		Feedback									
	a	b	c	d	T_p	T_i	T_a	T_b	T_f	T_D	K	DINV
IOBPCS	---	√	√	---	Fixed	Var.	Var.	0	∞	0	0	$100T_p$
DIOBPCS	---	√	√	---	Fixed	Var.	Var.	0	∞	T_p	0	0
VIOBPCS1	√	√	√	---	Fixed	Var.	Var.	T_a	∞	0	T_p	0
VIOBPCS2	√	√	√	---	Fixed	Var.	$T_p/2$	Var.	∞	0	T_p	0
CpIOBPCS	---	√	√	√	Fixed	Var.	$T_p/2$	0	Var.	0	0	$100T_p$

Table 6.2.2: Summary of the feed-forward and feedback paths used by the different structures in the study and their parameter values. (Ferris, 1993)

Where: -

T_p : was fixed throughout at 4 weeks and other values held constant as given above.

Var.: parameter value varied as part of the assessment of the family. The range over which individual parameter values were varied from $T_p/8$ to $4 T_p$

The system transfer functions for each of the family members are shown in Table 6.2.3. These functions describe how both production output and stock levels would be affected by any change in sales. The transfer functions are straightforward to obtain, given the information in Figure 6.2.2 and Table 6.2.3, by following the rules of block diagram

manipulation. Classical control theory offers several techniques by which these transfer functions can be interpreted to predict the system's dynamic behaviour (Towill, 1982).

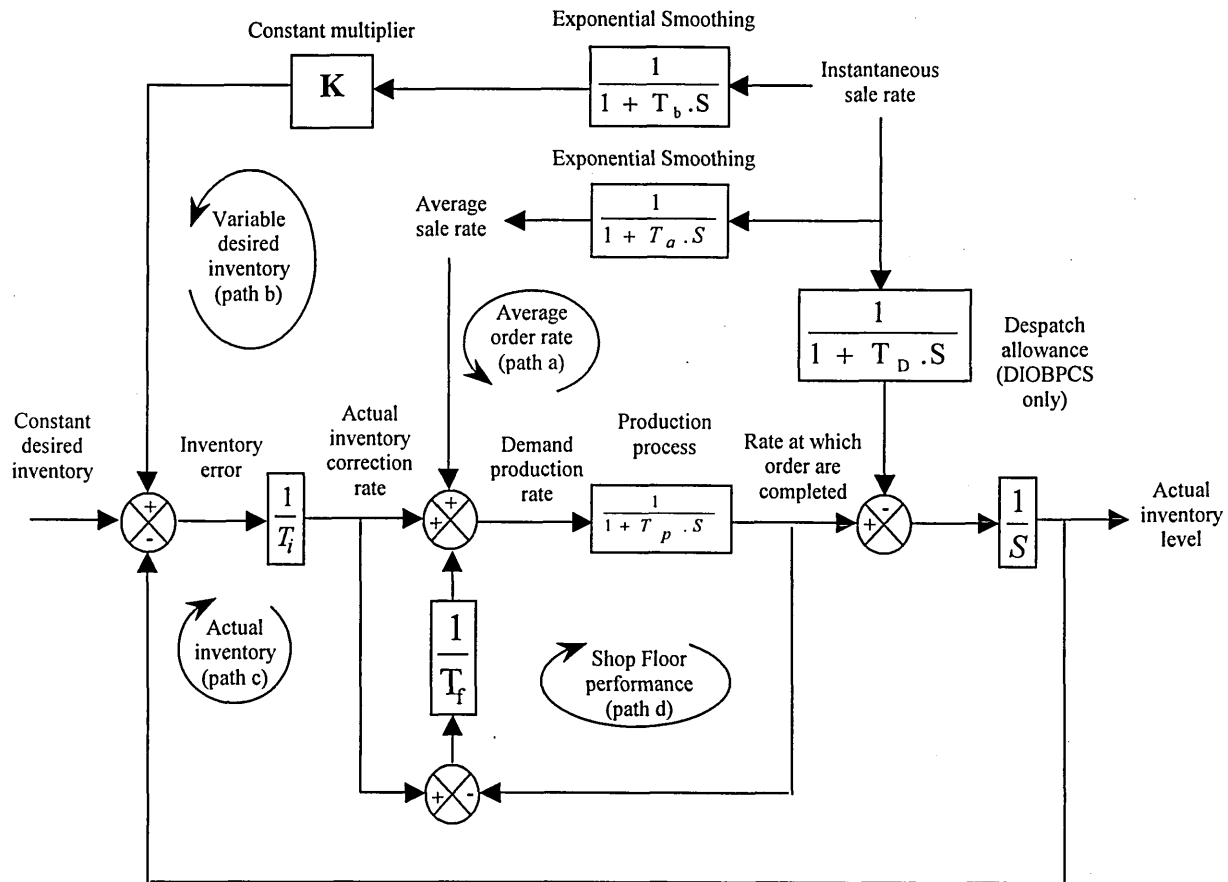

Figure 6.2.2: Block diagram of the generic family members: (Ferris, 1993)

IOBPCS: - constant Desired inventory (DINV) and paths b and c.

CPIOBPCS: - constant DINV and paths b, c, and d.

DIOBPCS: - constant DINV, despatch allowance and paths b and c.

VIOBPCS1: - paths a, b and c ($T_a = T_b$).

VIOBPCS2: - paths a, b and c ($T_a < T_b$).

Dynamic performance assessment

Any assessment should therefore be carried out across a wide range of parameter values within the region of absolute stability. The range chosen over which to vary the parameter values for individual family members is given in Table 6.2.2. The experimental design was such that only two parameter values were varied for any one family member. The choice of which combination to vary was made with regard to which parameter was likely to be the most influential on the behaviour characteristics (i.e. T_i) or formed part of the distinguishing feature of the family member in comparison

with IOBPCS. In every case the production lead-time (T_p) was fixed at four weeks as the benchmark for the other parameter values. The responses were assessed by a variety of measurements, e.g. for the pure step responses production output rise time, overshoot value and maximum stock level droop were selected.

Figure 6.2.3 shows typical step responses from these alternative plans of action. The different family members were clearly specialists. CPIOBPCS is the most complex system to operate but is a more responsive system whilst still providing the scope for stock level reduction. It is a good compromise performance, especially for operational characteristics that encourage inventory reduction. DIOBPCS is the smoothest system to operate but obviously requires tolerant customers or market dominance. Generally it reduces operational pressure due to sluggish market response requirements. VIOBPCS structures are those where the stock levels varied to reflect sales, stock holdings would fall with a falling market and rise to meet a buoyant one. Furthermore VIOBPCS systems are also very sensitive to constrain or varying production capabilities. VIOBPCS1 requires careful parameter selection, thought altering target stocks levels to reflect market needs. VIOBPCS2 is responsive to market need but weak in terms of production considerations.

Family member	$\left[\frac{\text{Production output (COMRATE)}}{\text{Sales}} \right]$	$\left[\frac{\text{Actual stock level (AINV)}}{\text{Sales}} \right]$
IOBPCS	$\frac{T_i s + (T_a s + 1)}{(1 + T_a s)(1 + T_i s + T_i T_p s^2)}$	$-T_i \left[\frac{(T_p + T_a) \cdot s + T_p T_a s^2}{(1 + T_a s)(1 + T_i s + T_i T_p s^2)} \right]$
DIOBPCS	$\frac{1 + (T_i + T_a) \cdot s + T_i T_p s^2}{(1 + T_a s)(1 + T_i s + T_i T_p s^2)(1 + T_p s)}$	$\frac{-T_i T_a s}{(1 + T_a s)(1 + T_i s + T_i T_p s^2)}$
VIOBPCS1	$\frac{1 + (T_i + T_a + K) \cdot s}{(1 + T_a s)(1 + T_i s + T_i T_p s^2)}$	$\frac{K - T_i \cdot (T_p + T_a) \cdot s + T_p T_a s^2}{(1 + T_a s)(1 + T_i s + T_i T_p s^2)}$
VIOBPCS2	$\frac{1 + (K + T_i + T_a + T_b) \cdot s + [T_a \cdot K + T_p \cdot (T_i + T_a)] \cdot s^2}{(1 + T_a s)(1 + T_b s)(1 + T_i s + T_i T_p s^2)}$	$\frac{K \cdot (1 + T_a s) - [T_i \cdot (T_p + T_a) \cdot s + T_p T_a s^2](1 + T_b s)}{(1 + T_a s)(1 + T_b s)(1 + T_i s + T_i T_p s^2)}$
CpIOBPCS	$\frac{(T_i + T_a) \cdot s + 1}{(1 + T_a s)(1 + T_i s + T_i \delta s^2)}$	$-T_i \left[\frac{(T_a + \delta) \cdot s + T_a \delta s^2}{(1 + T_a s)(1 + T_i s + T_i T_p s^2)} \right]$

Table 6.2.3: The system transfer functions for each of the generic family of structures considered (Ferris, 1993).

$$\text{Where: } \delta = T_p \left[1 + \frac{1}{T_f} \right]$$

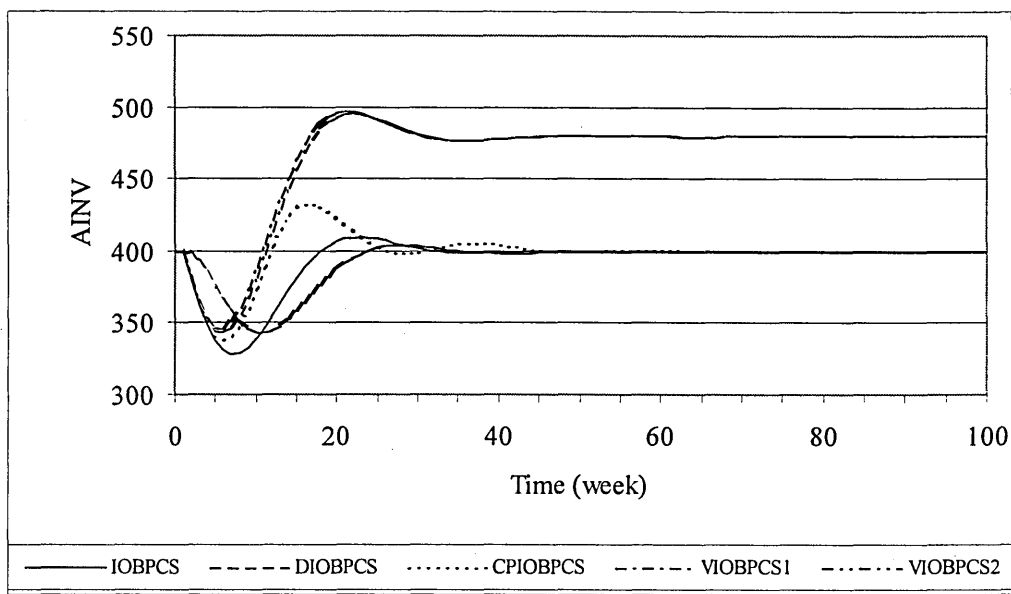

(a)

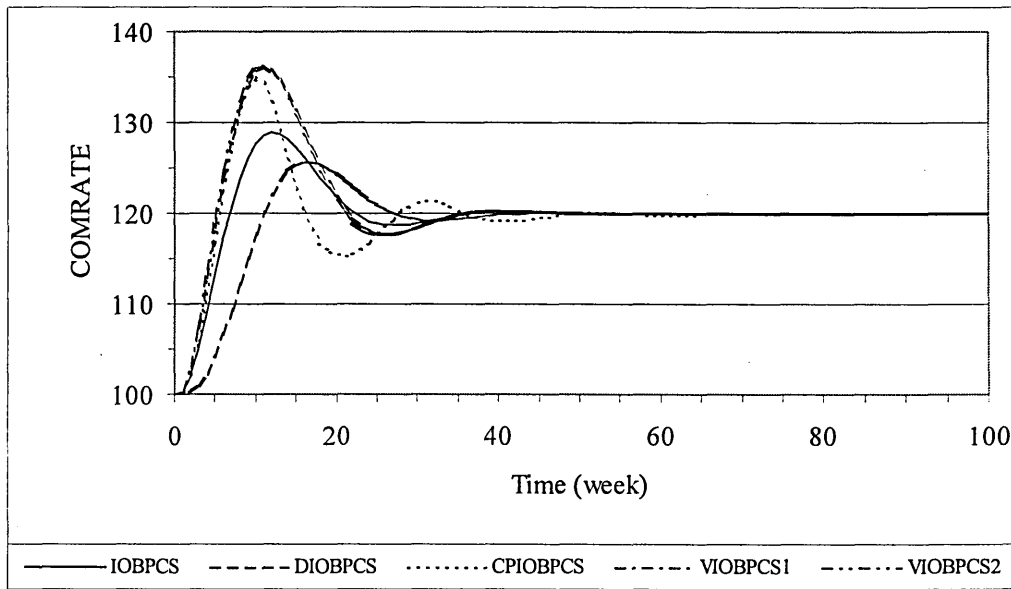

(b)

Figure 6.2.3: AINV and COMRATE comparative of IOBPCS, DIOBPCS, VIOBPCS1, VIOBPCS2 and CPIOBPCS behaviour ($T_i = 4$, $T_a = 4$) for the system step response to a change of 100 to 120 produced units per week in customer demand.

Conclusion

IOBPCS model is representative of much industrial practise associated with manual production control systems also it is a system for which an analytical solution exists, but it was the simplest effective structure considered and it is suitable for ensuring the accuracy of stock levels.

Each model from the generic family is typical of a branch of industrial practice. The most common model (IOBPCS) has been used as a datum against which the remaining four configurations have been compared on a strength-weaknesses basis. The potential user can then select for the design most clearly matching their performance specification. It is a feature of the generic family that it is in a form for expansion, ideally inspired by industrial case studies and theoretical justification. Computer simulation was used to find the criteria values for the step input responses of combinations of parameter values for the family members.

Finally the use of generic family has been tested on an industrial case study, which has been well documented (Edghill, 1990 & Olsmats, 1988). This evaluation proved the practical relevance of the family members selected and that access to the collated results of such a generic family could be a valuable short cut to understanding the dynamic behaviour exhibited by manufacturing systems. Table 6.2.4 summaries the main points of the IOBPCS generic family.

IOBPCS	<ul style="list-style-type: none"> Needs careful parameter selection but can match individual operational characteristics with respect to other family members
DIOBPCS	<ul style="list-style-type: none"> Generally reduces operational pressure due to sluggish market response requirements It is the smoothest system to operate but obviously requires tolerant customers or market dominance
VIOBPCS2	<ul style="list-style-type: none"> Response to market needs but weak in terms of production considerations
VIOBPCS1	<ul style="list-style-type: none"> Though altering target stock levels to reflect market needs, requires careful parameter selection VIOBPCS 1 & 2 structures are those where the stock levels varied to reflect sales; stock holdings would fall with a falling market and rise to meet a buoyant one. Though responsive, and a way of efficiently tailoring inventory profiles, the VIOBPCS systems are also very sensitive to constrained or varying production capabilities.
C _p IOBPCS	<ul style="list-style-type: none"> Good compromise performance, especially for operational characteristics that encourage inventory reduction It is the most complex system to operate but is a more responsive system whilst still providing the scope for stock level reduction

Table 6.2.4: Summary of the IOBPCS generic family

Reference

- Edghill, J. S., (1990), "The application of aggregate industrial dynamics techniques to manufacturing systems", Ph.D. Thesis, University of Wales College of Cardiff, Cardiff, Wales
- Ferris J.S., Towill D.R., (1993), "Benchmarking a generic family of Dynamic Manufacturing Ordering and Control Models", J Syst Eng, Vol. 3, pp 170-182.
- Olsmats C, Edghill J, Towill DR., (1988) "Industrial model building of a close-coupled production distribution system", Eng Costs Prod Econ, 13: 295-310
- Patching D., (1990), "Practical soft system analysis", Pitman, Chapter 2
- Towill D. R., (1982), "Dynamic analysis of an inventory and order based production control system", INT. J. PROD. RES., VOL. 20, No. 6, PP 671-687

DELAYS REPRESENTING

A delay is essentially a conversion process that accepts a given inflow rate and delivers a resulting flow rate at the output. The outflow may differ instant by instant from the inflow rate under dynamic circumstances where the rates are changing in value. This necessarily implies that the delay contains a variable amount of the quantity in transit. The content of the delay increases whenever the inflow exceeds the outflow, and vice versa.

The concept of delay implies that resources or information will be held up relative to other flows in the system. This suggests that delays can be represented by levels. In other words how the practical effect of T_p (production delay) can be represent in difference equation form. The type of delay used in the simulation can vary according to the system designer. Figure 6.3.1 shows the simplest form of a resource delay in influence diagram form. This delay, which consists of one delaying level only, is referred to as a first-order resource delay and has already been encountered in the basic structure of the skill model. Figure 6.3.2 shows a third-order resource delay its associated equations, where the total delay (DEL) is split into three equal parts to control the resource flow between three levels.

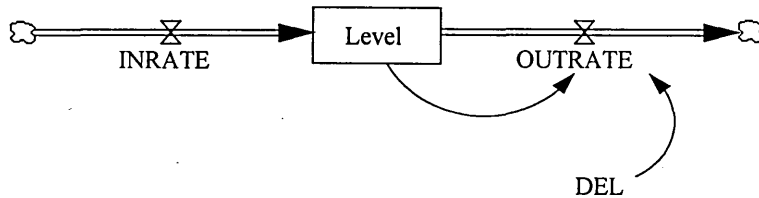

Figure 6.3.1: Influence diagram for a first-order resource delay.

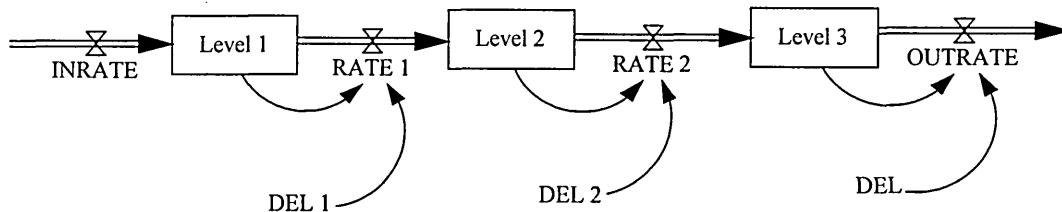

Figure 6.3.2: Influence diagram for a third-order resource delay.

Three possible delay representations are shown in Figures 6.3.3, 6.3.4 and 6.3.5. The concept of delays applied to information flows creates the idea of a level within an information flow. Such an information level has already been encountered in the skill model and is commonly known as a smoothed level. This differs from a resource level and its name arises from the fact that delaying of information effectively represents smoothing of information.

The easiest way to understand the effect of delays on system behaviour is to consider the response of a delay to impulse and step input. Figures 6.3.3, 6.3.4 and 6.3.5 show selections from the exponential family. In the Figures the solid line represents the input to the delay; the dotted line shows the output. Time moves to the right along the horizontal axis. In each Figure the left-hand diagram is for an impulse input; that is, a quantity is inserted into the delay in a negligibly short time, and the dotted line shows the rate of arrival at the output. In the right-hand diagram, the input is a sudden step increase in input rate, and the dotted line again shows the resulting output rate. Figure 6.3.3 shows a first-order exponential delay. In Figure 6.3.3a the maximum rate of output occurs immediately after an impulse input, and the output rate declines exponentially thereafter. Figure 6.3.3b represents a step change in input rate and the resulting exponential rise in output rate from a first-order delay. The area between the solid and dotted curves is a measure of the quantity that accumulates in the in-transit level in the delay. So long as there is a flow through the delay, the total amount delivered at the output is less than total amount that has been put in.

Figure 6.3.4 is the output response of a second-order exponential delay. The second-order delay is the equivalent of two first-order delays cascaded one after the other so that the output of the first is the input to the second. In Figure 6.3.4a the initial output rate in response to an impulse input is zero, and the output curve has its maximum slope at the origin. In Figure 6.3.5 is a third-order exponential delay. This shape of output response is the first of the sequence that satisfies the more obvious characteristics of the actual shipping process. In Figure 6.3.5a the output response to an impulse input is initially zero. Also the initial slope of the output curve is zero. The curve begins to rise slowly, reaches a maximum slope and then a peak value, and falls off. In Figure 6.3.5b is the output following a step change in the input rate.

To refine the delay function further would require a careful study in the actual system of item-by-item delays and their time distribution. It is unlikely that any further on refinement will have appreciable effect on system behaviour.

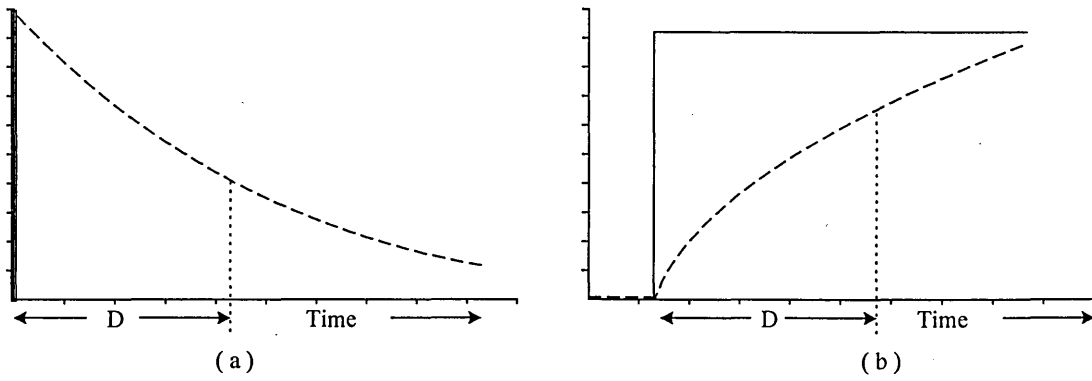

Figure 3.3: First-order exponential delay

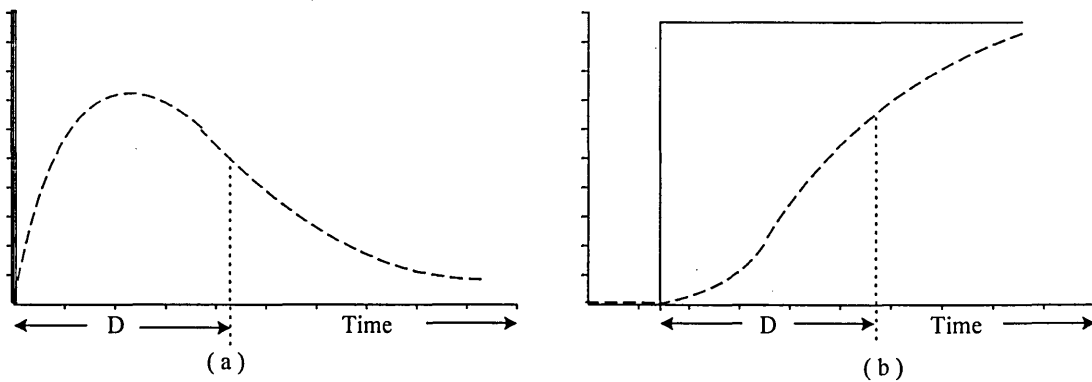

Figure 3.4: Second-order exponential delay

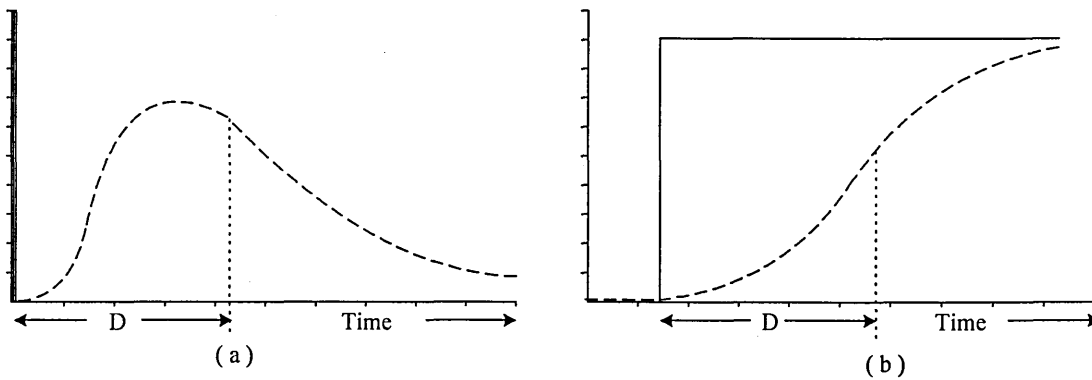

Figure 3.5: Third-order exponential delay

Reference:

Forrester J.W., (1961), "Industrial Dynamics", MIT Press, Cambridge, Mass.

KNOWLEDGE AND COMPETENCE BLOCK DIAGRAMS

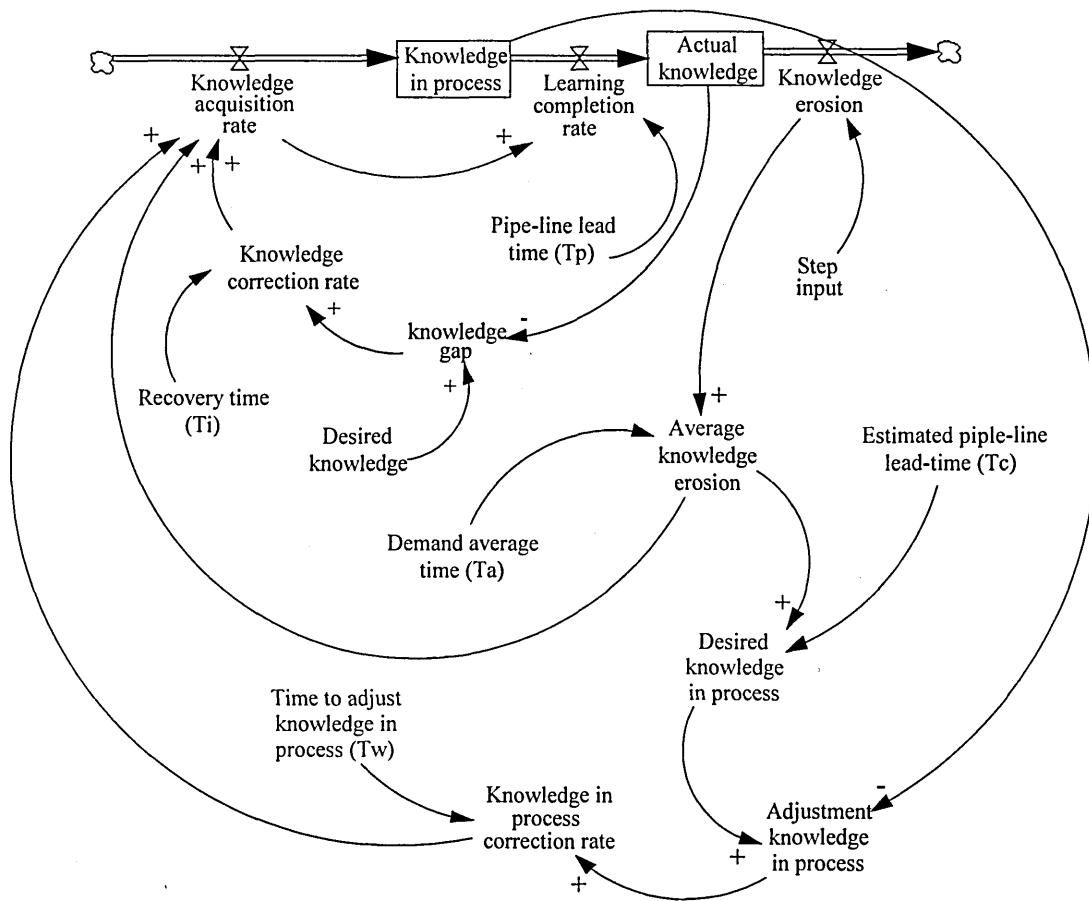

Figure 6.4.1: The influence diagram of knowledge model

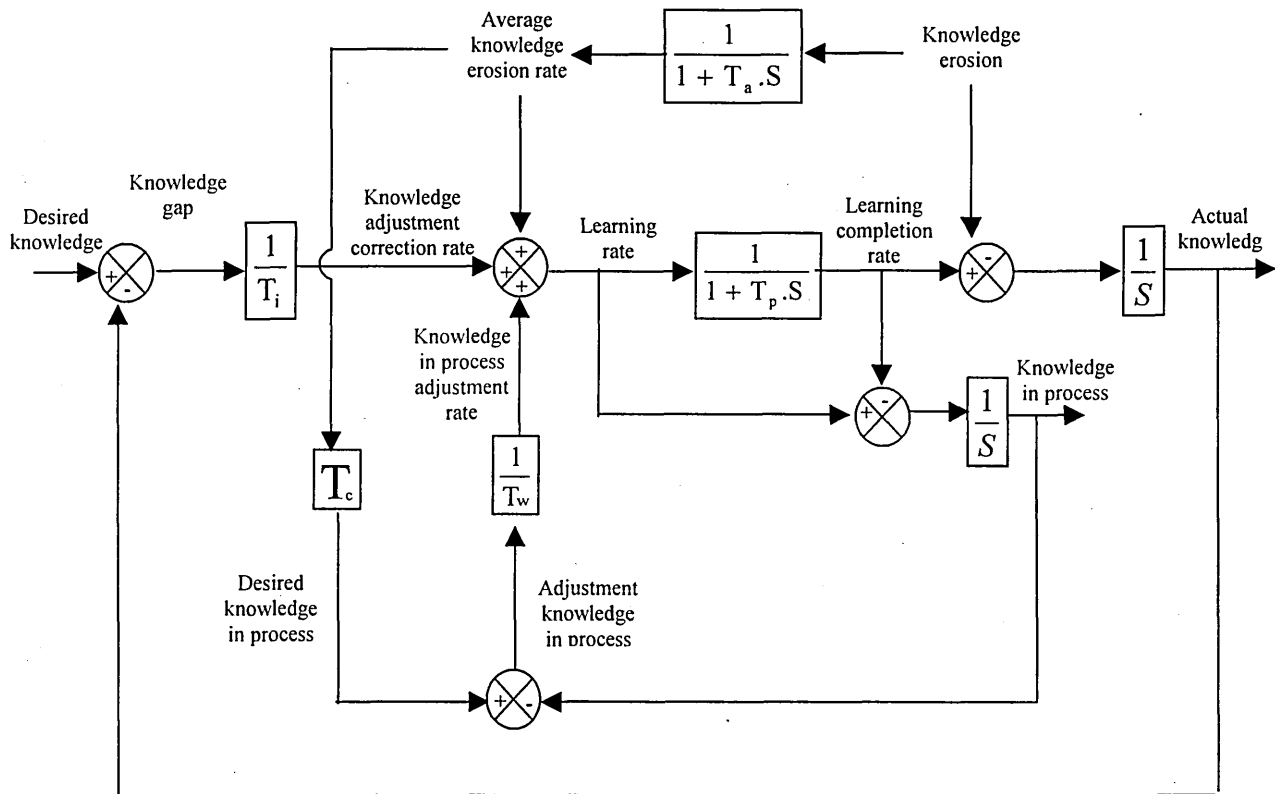

Figure 6.4.2: Block diagram of knowledge model

The transfer functions of knowledge model are: -

$$\frac{\text{Actual knowledge level}}{\text{Knowledge erosion rate}} = -T_i \frac{\left[\frac{(T_p - T_c)}{T_w} + \left(T_a + T_p + \frac{T_a T_p}{T_w} \right) \cdot S + T_a T_p S^2 \right]}{\left(1 + T_a S \right) \left(1 + \left(1 + \frac{T_p}{T_w} \right) \cdot T_i S + T_p T_i S^2 \right)} \quad (6.4.1)$$

$$\frac{\text{Learning completion rate}}{\text{Knowledge erosion rate}} = \frac{1 + \left(T_a + T_i + \frac{T_c T_i}{T_w} \right) \cdot S}{\left(1 + T_a S \right) \left(1 + \left(1 + \frac{T_p}{T_w} \right) \cdot T_i S + T_p T_i S^2 \right)} \quad (6.4.2)$$

$$\frac{\text{Knowledge in process level}}{\text{Knowledge erosion rate}} = T_p \frac{\left[1 + \left(T_a + T_i + \frac{T_i T_c}{T_w} \right) \cdot S \right]}{\left(1 + T_a S \right) \left(1 + \left(1 + \frac{T_p}{T_w} \right) \cdot T_i S + T_p T_i S^2 \right)} \quad (6.4.3)$$

Where learning is defined as: -

Learning is the process by which existing knowledge is enriched or new knowledge is created (Van Solingen et al, 2000). Learning deals with expanding knowledge. Knowledge is the personal ability that enables a person to perform a certain task. This ability is the product of information, experience, skill and attitude of a person at a certain time (Van Solingen et al, 2000).

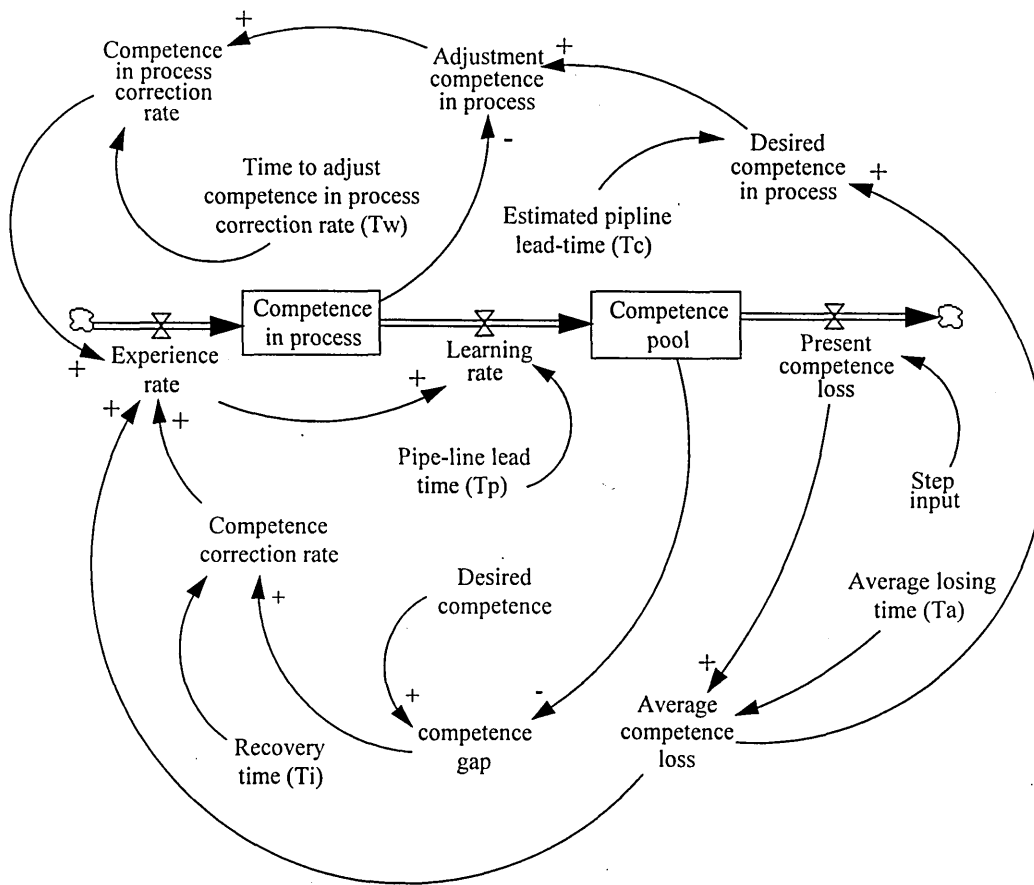

Figure 6.4.3: The influence diagram of competence model

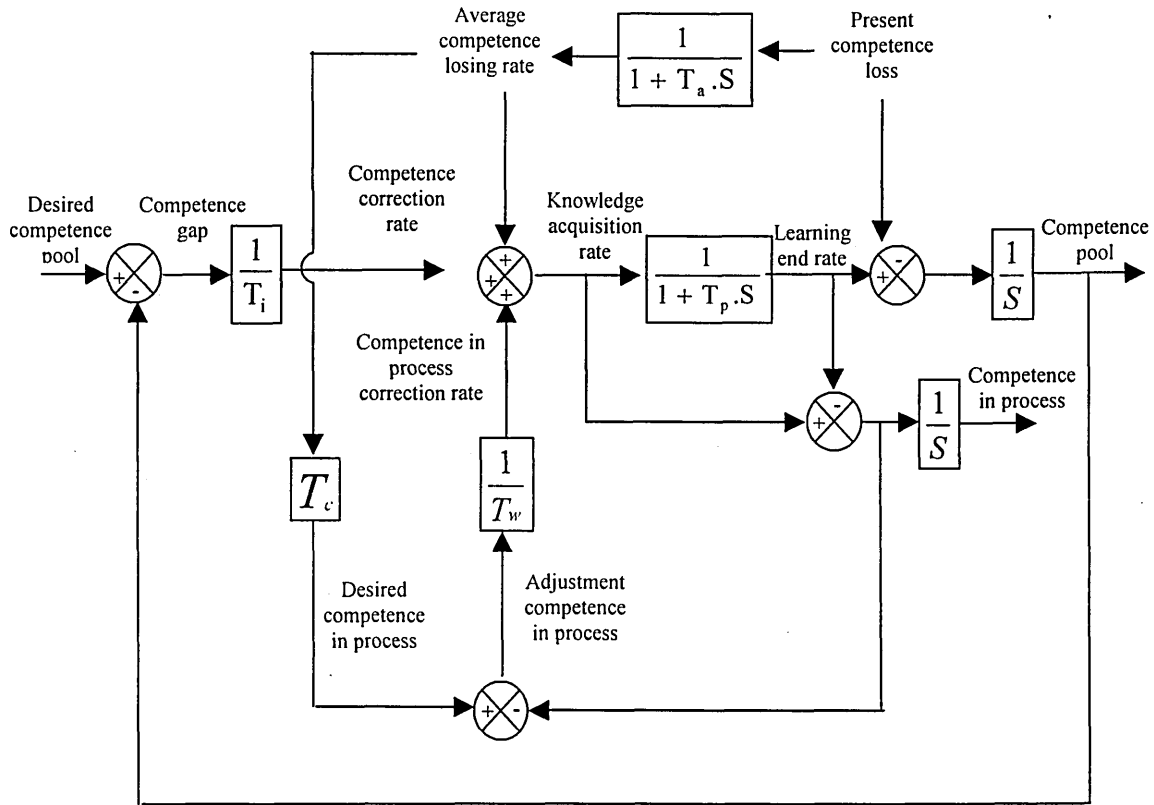

Figure 6.4.4: Block diagram of competence model

The transfer functions of competence model are: -

$$\frac{\text{Competence pool}}{\text{Present loss competence rate}} = -T_i \left[\frac{\left(\frac{T_p - T_c}{T_w} + \left(T_a + T_p + \frac{T_a T_p}{T_w} \right) \cdot S + T_a T_p S^2 \right)}{(1 + T_a S) \left(1 + \left(1 + \frac{T_p}{T_w} \right) \cdot T_i S + T_p T_i S^2 \right)} \right] \quad (6.4.4)$$

$$\frac{\text{Learning rate}}{\text{Present loss competence rate}} = \frac{1 + \left(T_a + T_i + \frac{T_c T_i}{T_w} \right) \cdot S}{(1 + T_a S) \left(1 + \left(1 + \frac{T_p}{T_w} \right) \cdot T_i S + T_p T_i S^2 \right)} \quad (6.4.5)$$

$$\frac{\text{Competence in process level}}{\text{Present loss competence rate}} = T_p \left[\frac{1 + \left(T_a + T_i + \frac{T_i T_c}{T_w} \right) \cdot S}{(1 + T_a S) \left(1 + \left(1 + \frac{T_p}{T_w} \right) \cdot T_i S + T_p T_i S^2 \right)} \right] \quad (6.4.6)$$

Where: the definition of competence is:

The competence is defined as the set of skills and knowledge that an individual needs in order effectively to perform a specified job (Baker, 1997).

Reference

- Van Solingen R., Berghout E., Kusters R., Trienekens J., (2000), "From process improvement to people improvement: enabling learning in software development", *Information and Software Technology*, Vol. 42, 965-971
- Baker J.C., Mapes J., New C.C., Szwejcowski M., (1997), "A hierarchical model of business competence", *Integrated Manufacturing Systems*, Vol. 8, No. 5, PP. 265-272

APPENDIX 7.1

PSKPM TRANSFER FUNCTION

Investigation of the transfer functions

For the PSKPM model: -

$$DLSKP = DSKIP = 0$$

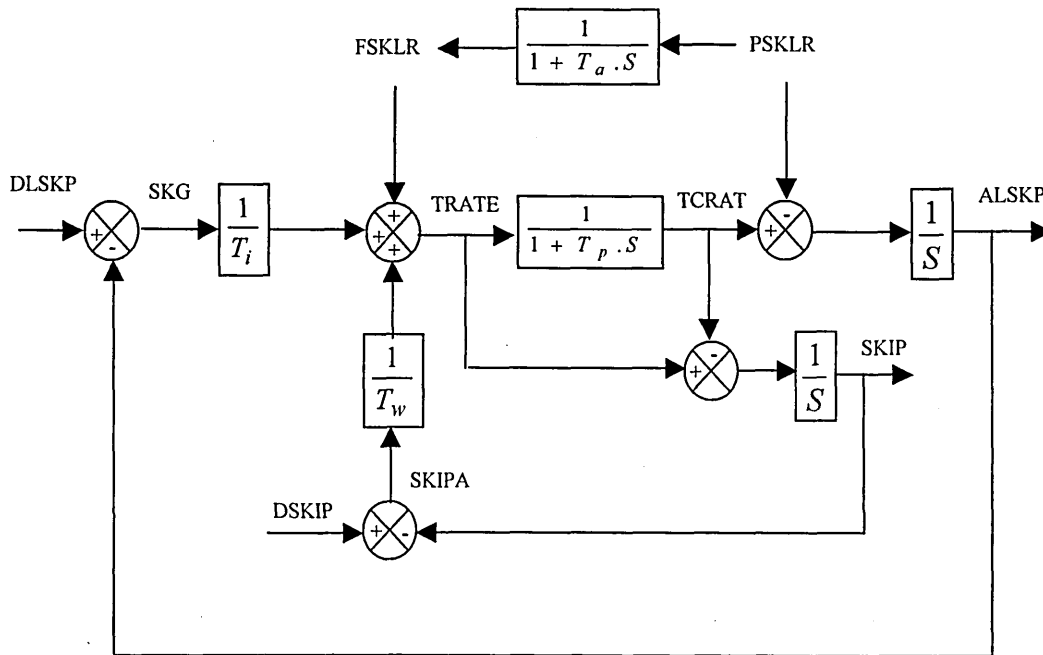

Figure 7.1.1: PSKPM Block diagram

The extra feedback algorithm can be reduced to one block as shown the following.

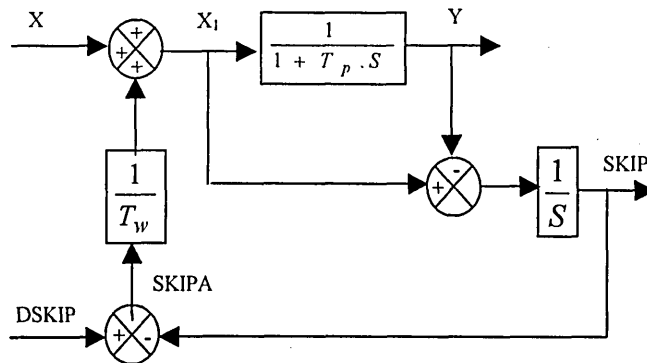

Figure 7.1.2: The extra feedback loop.

From Figure 7.1.2: -

$$Y = X_1 \left(\frac{1}{1 + T_p S} \right) \quad (7.1.1)$$

$$SKIP = (X_1 - Y) \left(\frac{1}{S} \right) \quad (7.1.2)$$

$$SKIPA = -SKIP \quad (7.1.3)$$

$$X_1 = X - SKIP \left(\frac{1}{T_w} \right) \quad (7.1.4)$$

From Equations (7.1.1) and (7.1.2)

$$SKIP = [Y(1 + T_p S) - Y] \left(\frac{1}{S} \right)$$

$$SKIP = YT_p \quad (7.1.5)$$

From Equations (7.1.5) and (7.1.4)

$$X_1 = X - YT_p \left(\frac{1}{T_w} \right) \quad (7.1.6)$$

Equating Equation 7.1.6 and 7.1.1

$$X = Y \left(1 + T_p S + \frac{T_p}{T_w} \right) \quad (7.1.7)$$

This reduces the block diagram shown in Figure 7.1.1 to: -

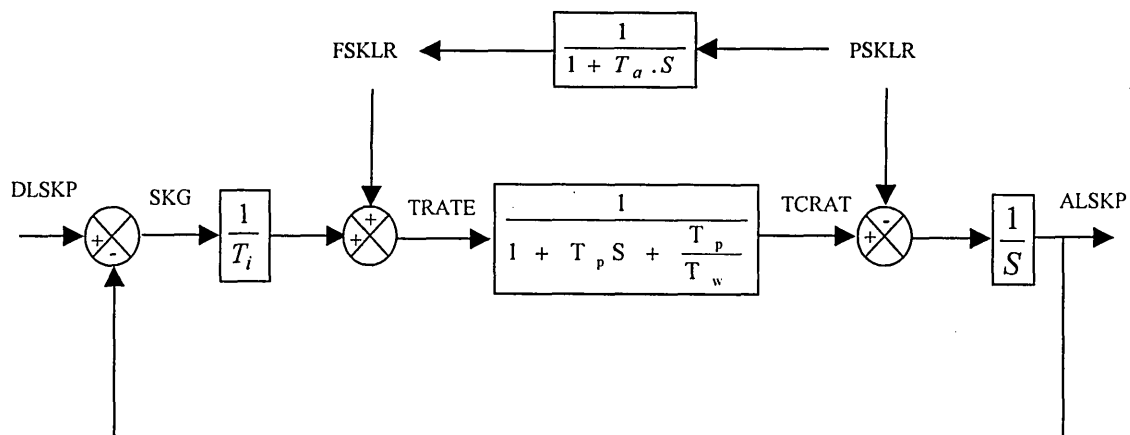

Figure 7.1.3: The reduced block diagram.

The equations can be written down directly from Figure 7.1.3 using the block diagram analysis. These equations are: -

$$SKG = DLSKP - ALSKP \quad (7.1.8)$$

$$FSKLR = PSKLR \cdot \left(\frac{1}{1 + T_a \cdot S} \right) \quad (7.1.9)$$

$$TRATE = FSKLR + SKG \cdot \left(\frac{1}{T_i} \right) \quad (7.1.10)$$

$$TCRATE = TRATE \cdot \left(\frac{1}{1 + T_p \cdot S + \left(\frac{T_p}{T_w} \right)} \right) \quad (7.1.11)$$

$$ALSKP = \left(\frac{1}{S} \right) \cdot (TCRATE - PSKLR) \quad (7.1.12)$$

Equations (7.1.8) to (7.1.12) are solved in the order listed to develop the actual level of skill pool/present skill loss rate (ALSKP/PSKLR) and training completion rate/present skill loss rate (TCRATE/PSKLR) transfer functions.

$$\frac{ALSKP}{PSKLR} = -T_i \frac{\left[\frac{T_{pc}}{T_w} + \left(T_a + T_p + \frac{T_a T_p}{T_w} \right) \cdot S + T_a T_p S^2 \right]}{\left(1 + T_a S \right) \left(1 + \left(1 + \frac{T_p}{T_w} \right) \cdot T_i S + T_p T_i S^2 \right)} \quad (7.1.13)$$

$$\frac{TCRATE}{PSKLR} = \frac{1 + (T_a + T_i) \cdot S}{\left(1 + T_a S \right) \left(1 + \left(1 + \frac{T_p}{T_w} \right) \cdot T_i S + T_p T_i S^2 \right)} \quad (7.1.14)$$

The SKIP transfer function is derived algebraically from Figure 7.1.1 as follows.

$$TRATE = TCRATE \cdot (1 + T_p \cdot S) \quad (7.1.15)$$

$$SKIP = (TRATE - TCRATE) \cdot \left(\frac{1}{S}\right) \quad (7.1.16)$$

From Equations (7.1.15) and (7.1.16)

$$TCRATE = \frac{SKIP}{T_p} \quad (7.1.17)$$

$$TRATE = SKG \cdot \left(\frac{1}{T_i}\right) + SKIPA \cdot \left(\frac{1}{T_w}\right) + FSKLR \quad (7.1.18)$$

$$SKG = - ALSKP$$

$$ALSKP = \left(\frac{1}{S}\right)(TCRATE - PSKLR) \quad (7.1.19)$$

From Equations (7.1.17) and (7.1.19)

$$ALSKP = \left(\frac{1}{T_p \cdot S}\right)(SKIP - PSKLR \cdot T_p) \quad (7.1.20)$$

$$SKIPA = - SKIP \quad (7.1.21)$$

$$FSKLR = PSKLR \cdot \left(\frac{1}{1 + T_a \cdot S}\right) \quad (7.1.22)$$

From Equations (7.1.20), (7.1.21), (7.1.22) and (7.1.18)

$$TRATE = - \left(\frac{SKIP - PSKLR \cdot T_p}{T_p \cdot T_i \cdot S}\right) - \left(\frac{SKIP}{T_w}\right) + \left(\frac{PSKLR}{1 + T_a \cdot S}\right) \quad (7.1.23)$$

From Equations (7.1.15), (7.1.17) and (7.1.23) the transfer function of SKIP is the following.

$$\boxed{\frac{SKIP}{PSKLR} = T_p \left[\frac{1 + (T_a + T_i) \cdot S}{(1 + T_a S) \left(1 + \left(1 + \frac{T_p}{T_w}\right) \cdot T_i S + T_p T_i S^2\right)} \right]} \quad (7.1.24)$$

INVESTIGATION OF THE DESIGN PARAMETERS SETTING

Investigation of the design parameter setting

The transfer function models of the APSKPM are :-

$$\frac{ALSKP}{PSKLR} = -T_i \left[\frac{\left(\frac{T_p - T_c}{T_w} + \left(T_a + T_p + \frac{T_a T_p}{T_w} \right) \cdot S + T_a T_p S^2 \right)}{\left(1 + T_a S \right) \left(1 + \left(1 + \frac{T_p}{T_w} \right) \cdot T_i S + T_p T_i S^2 \right)} \right] \quad (7.2.1)$$

$$\frac{TCRATE}{PSKLR} = \frac{1 + \left(T_a + T_i + \frac{T_c T_i}{T_w} \right) \cdot S}{\left(1 + T_a S \right) \left(1 + \left(1 + \frac{T_p}{T_w} \right) \cdot T_i S + T_p T_i S^2 \right)} \quad (7.2.2)$$

$$\frac{SKIP}{PSKLR} = T_p \left[\frac{1 + \left(T_a + T_i + \frac{T_i T_c}{T_w} \right) \cdot S}{\left(1 + T_a S \right) \left(1 + \left(1 + \frac{T_p}{T_w} \right) \cdot T_i S + T_p T_i S^2 \right)} \right] \quad (7.2.3)$$

Equations (7.2.1), (7.2.2) and (7.2.3) are useful to understand how the design parameters T_a , T_i and T_w to be set by the system designer, interact and affect the ALSKP dynamic recovery pattern. Equations (7.2.1), (7.2.2) and (7.2.3) can be normalized. So that the effect of the design parameters can be more readily observed.

$$\left. \begin{aligned} \lambda_a &= \frac{T_a}{T_p} \\ \lambda_i &= \frac{T_i}{T_p} \\ \lambda_w &= \frac{T_w}{T_p} \\ \lambda_c &= \frac{T_c}{T_p} \end{aligned} \right\} \quad (7.2.4)$$

Since T_p will now occur everywhere that s occurs, it will also simplify matters to define a normalized Laplace operator, $S = T_p s$, leading to normalized time (T/T_p) as a convenient horizontal axis. The normalised transfer functions are now: -

$$\frac{ALSKP}{PSKLR} = -\lambda_i T_p \left[\frac{\frac{(1-\lambda_c)}{\lambda_w} + \left(1 + \lambda_a + \frac{\lambda_a}{\lambda_w}\right) \cdot S + \lambda_a S^2}{(1 + \lambda_a S) \left(1 + \left(1 + \frac{1}{\lambda_w}\right) \cdot \lambda_i S + \lambda_i S^2\right)} \right] \quad (7.2.5)$$

$$\frac{TCRATE}{PSKLR} = \frac{1 + \left(\lambda_a + \lambda_i + \frac{\lambda_c \lambda_i}{\lambda_w}\right) \cdot S}{(1 + \lambda_a S) \left(1 + \left(1 + \frac{1}{\lambda_w}\right) \cdot \lambda_i S + \lambda_i S^2\right)} \quad (7.2.6)$$

$$\frac{SKIP}{PSKLR} = T_p \left[\frac{1 + \left(\lambda_a + \lambda_i + \frac{\lambda_i \lambda_c}{\lambda_w}\right) \cdot S}{(1 + \lambda_a S) \left(1 + \left(1 + \frac{1}{\lambda_w}\right) \cdot \lambda_i S + \lambda_i S^2\right)} \right] \quad (7.2.7)$$

The quadratic term in the transfer functions in Equations (7.2.5), (7.2.6) and (7.2.7), which emanates from the feedback loops, can be written in the standard second order form in control theory (Marshall 1986). The characteristic equation is: -

$$\left[1 + \frac{2\zeta}{\omega_n} S + \frac{1}{\omega_n^2} S^2 \right] \quad (7.2.8)$$

Where: -

ω_n is the undamped natural frequency

ζ is the damping ratio

The damping ratio is regarded by systems engineers as a direct measure of system performance. A value of $\zeta > 1$ indicates a system which is over damped (which can imply long recovery times), whilst $\zeta < 1$ denotes a system that is under damped. A value of $\zeta = 1$ indicates that a system is critically damped. The ideal values of $0.5 < \zeta < 0.707$ are considered to be ideal (Towill, 1982).

Equating the quadratic term of the transfer functions in Equations (7.2.5), (7.2.6), (7.2.7) and (7.2.8) give the following relationships: -

$$\left. \begin{aligned} \frac{2\zeta}{\omega_n} &= \left(1 + \frac{1}{\lambda_w}\right) \cdot \lambda_i \\ \frac{1}{\omega_n^2} &= \lambda_i \end{aligned} \right\} \quad (7.2.9)$$

The relationship between ζ , λ_i and λ_w can be determined from Equation (7.2.9) as the following.

$$\zeta = 0.5 \cdot \sqrt{\lambda_i} \cdot \left(1 + \frac{1}{\lambda_w}\right) \quad (7.2.10)$$

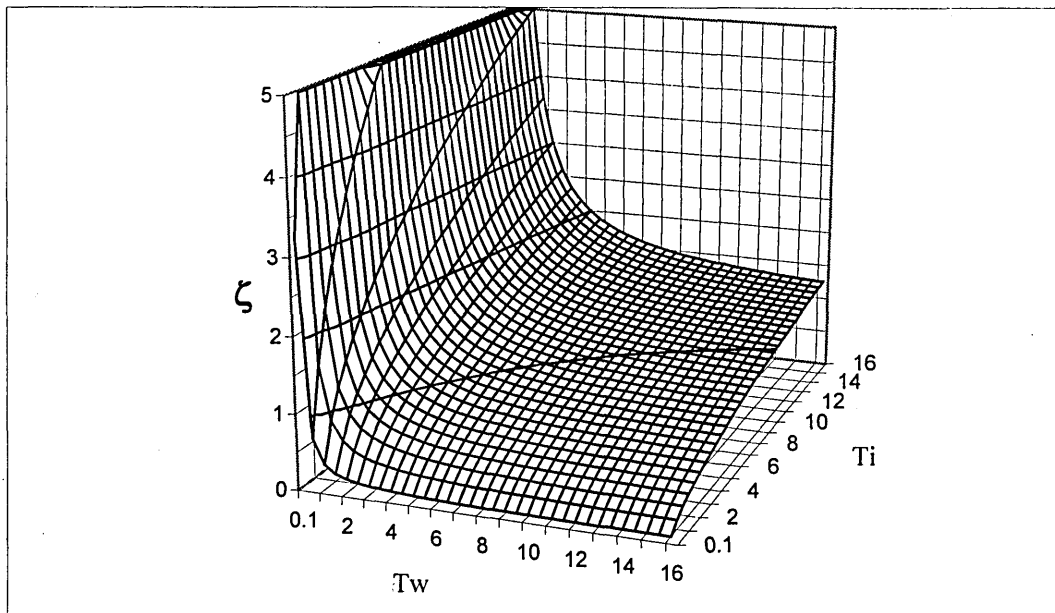

Figure 7.1: The relationships between the damping ratio ζ , T_w and T_i .

Equations (7.2.1), (7.2.2) and (7.2.3) are useful to understand how the design parameters T_a , T_i and T_w to be set by the system designer, interact and affect the ALSKP dynamic recovery pattern. Equations (7.2.1), (7.2.2) and (7.2.3) can be normalized. So that the effect of the design parameters can be more readily observed.

Figure 7.1 shows a three dimensional relationships between ζ , T_w and T_i . T_w and T_i have been varied between 1 and 16 respectively. Figure 7.1 will be used to determine the boundary limit of the parameter T_w , and T_i for an ideal range of values for ζ .

It can be seen that for $T_i \geq 10$ the value of ζ is greater than one (i.e. the system is over damping). Therefore the design parameter T_i is setting as $0 < T_i \leq 10$. whereas the parameter settings for T_w ranging as $0 < T_w \leq 16$ which have ideal values of ζ . The following sections investigate the performance criteria of the APIOBPCS model using the values of the design parameters as $1 \leq T_i \leq 8$ and $1 \leq T_w \leq 16$. These parameters settings give values of $\zeta \approx 0.75$, which is within the acceptable design criteria.

References

- Marshall, S. A., (1986), "Introduction to control theory", Published by Macmillan Education Limited, ISBN 0-333-18311-8, Chapter 5
- Towill, D. R., (1982), "Dynamic analysis of an inventory and order based production control system", IJPR, Vol. 20, No 6, PP. 671-687.

APPENDIX 7.3

PSKPM ITHINK MODEL

The following figure shows the PSKPM simulation model using the *ithink* software.

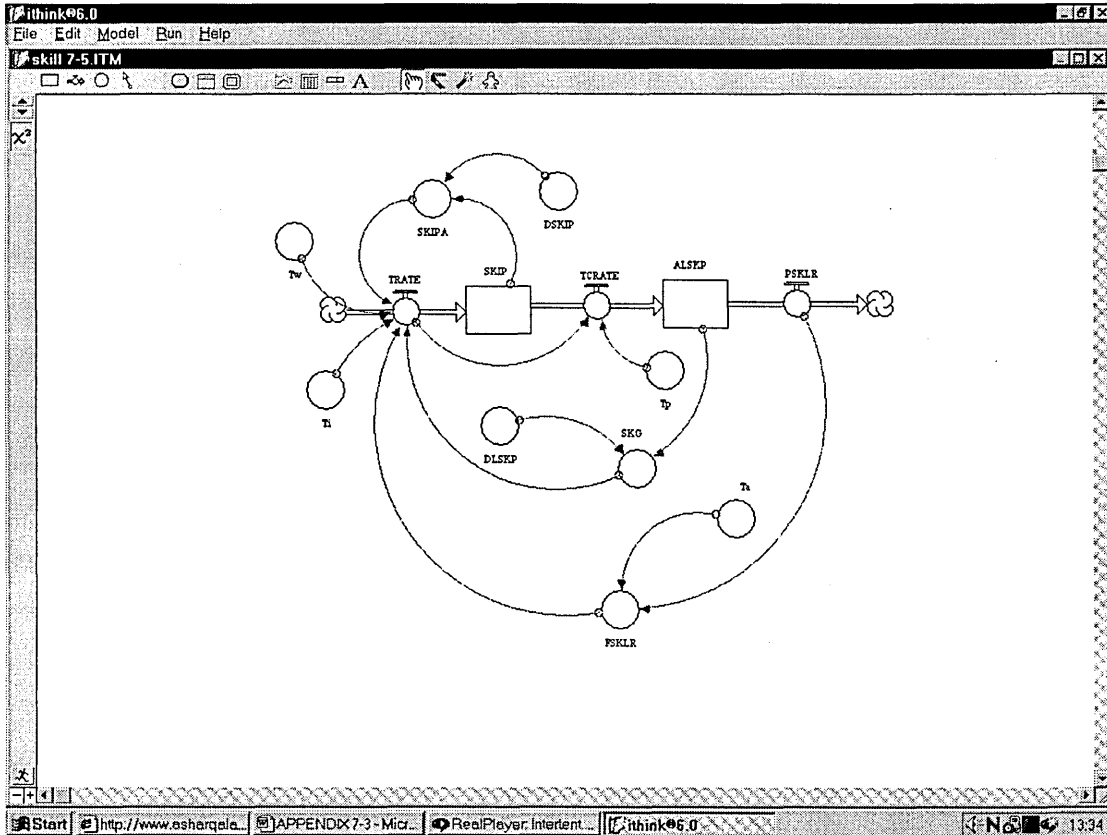

Figure 7.3.1: PSKPM model

The *ithink* simulation equations for the PSKPM model are:

$$\text{ALSKP}(t) = \text{ALSKP}(t - dt) + (\text{TCRATE} - \text{PSKLR}) * dt$$

$$\text{INIT ALSKP} = \text{DLSKP}$$

INFLOWS:

$$\text{TCRATE} = \text{SMTH1}(\text{TRATE}, T_p)$$

OUTFLOWS:

$$\text{PSKLR} = \text{STEP}(20,1)+100$$

$$\text{SKIP}(t) = \text{SKIP}(t - dt) + (\text{TRATE} - \text{TCRATE}) * dt$$

$$\text{INIT SKIP} = \text{FSKLR} * \text{Tp}$$

INFLOWS:

$$\text{TRATE} = (\text{SKG}/\text{Ti}) + \text{FSKLR} + (\text{SKIPA}/\text{Tw})$$

OUTFLOWS:

$$\text{TCRATE} = \text{SMTH1}(\text{TRATE}, \text{Tp})$$

$$\text{DLSKP} = 400$$

$$\text{DSKIP} = 400$$

$$\text{FSKLR} = \text{SMTH1}(\text{PSKLR}, \text{Ta})$$

$$\text{SKG} = \text{DLSKP} - \text{ALSKP}$$

$$\text{SKIPA} = \text{DSKIP} - \text{SKIP}$$

$$\text{Ta} = 4$$

$$\text{Ti} = 4$$

$$\text{Tp} = 4$$

$$\text{Tw} = 4$$

APSKPM TRANSFER FUNCTIONS

Investigation of the APSKPM transfer functions

The transfers functions of the APSKPM can be derived algebraically form the block diagram as shown in Figure 7.4.1 as following: -

For the APSKPM model: -

DLSKP = 0

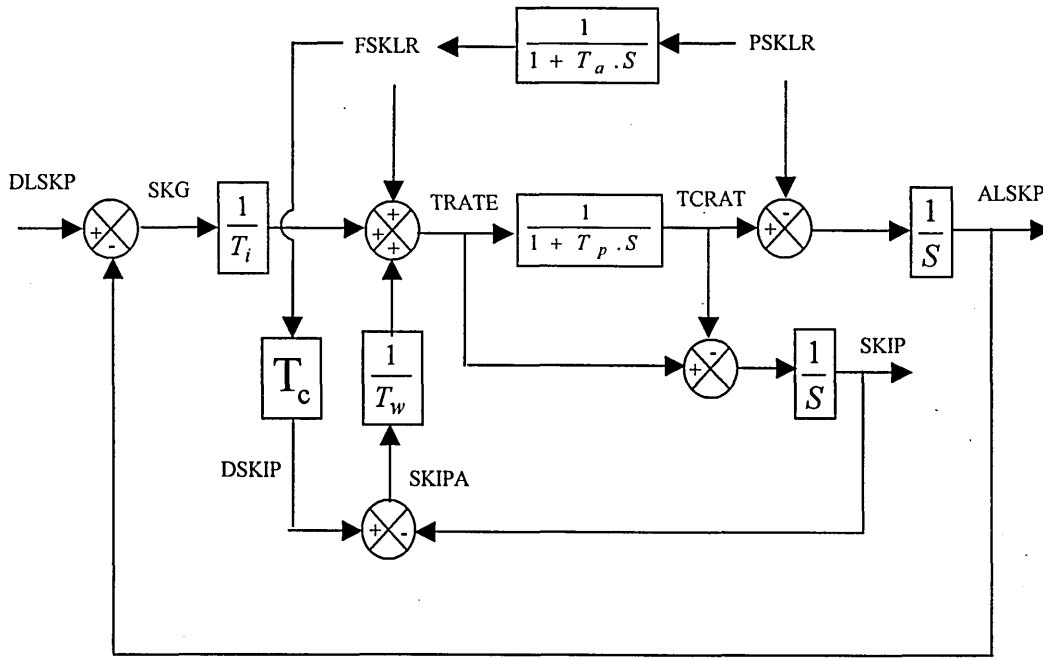

Figure 7.4.1: APSKPM block diagram

The (ALSKP/PSKLR) transfer function is derived algebraically from Figure 7.1.1 as follows.

$$TRATE = TCRATE \cdot (1 + T_p \cdot S) \quad (7.4.1)$$

$$SKIP = (TRATE - TCRATE) \cdot \left(\frac{1}{S}\right) \quad (7.4.2)$$

From Equations (7.4.1) and (7.4.2)

$$TCRATE = \frac{SKIP}{T_p} \quad (7.4.3)$$

$$TRATE = SKG \cdot \left(\frac{1}{T_i}\right) + SKIPA \cdot \left(\frac{1}{T_w}\right) + FSKLR \quad (7.4.5)$$

$$SKG = -ALSKP \quad (7.4.6)$$

$$ALSKP = \left(\frac{1}{S}\right)(TCRATE - PSKLR) \quad (7.4.7)$$

From Equations (7.4.7) and (7.4.3)

$$SKIP = T_p \cdot S \left(ALSKP - PSKLR \cdot \left(\frac{1}{S}\right) \right) \quad (7.4.8)$$

$$SKIPA = T_c \left(\frac{1}{1 + T_a S} \right) PSKLR - T_p \cdot S \left(ALSKP - PSKLR \cdot \left(\frac{1}{S}\right) \right) \quad (7.4.9)$$

$$FSKLR = PSKLR \cdot \left(\frac{1}{1 + T_a \cdot S} \right) \quad (7.4.10)$$

From Equations (7.4.5), (7.4.6), (7.4.9) and (7.4.10)

$$\begin{aligned} TRATE = & -ALSKP \cdot \left(\frac{1}{T_i}\right) \\ & + \left(T_c \left(\frac{1}{1 + T_a S} \right) PSKLR - T_p \cdot S \left(ALSKP - PSKLR \cdot \left(\frac{1}{S}\right) \right) \right) \cdot \left(\frac{1}{T_w}\right) \\ & + PSKLR \cdot \left(\frac{1}{1 + T_a \cdot S} \right) \end{aligned} \quad (7.4.11)$$

From Equations (7.4.1), (7.4.3) and (7.4.8)

$$TRATE = (1 + T_p \cdot S) \left(ALSKP - PSKLR \cdot \left(\frac{1}{S}\right) \right) \cdot S \quad (7.4.12)$$

By equating Equations (7.4.11) and (7.4.12) the (ALSKP/PSKLR) transfer function is

$$\boxed{\frac{ALSKP}{PSKLR} = -T_i \frac{\left[\frac{(T_p - T_c)}{T_w} + \left(T_a + T_p + \frac{T_a T_p}{T_w} \right) \cdot S + T_a T_p S^2 \right]}{\left(1 + T_a S \right) \left(1 + \left(1 + \frac{T_p}{T_w} \right) \cdot T_i S + T_p T_i S^2 \right)}} \quad (7.4.13)$$

The derivation of the (ALSKP/PSKLR) transfer function is as follows: -

From Equations (7.4.7) and (7.4.11)

$$\begin{aligned}
TRATE &= -\left(\frac{1}{T_i}\right) \cdot \left(\frac{1}{S}\right) (TCRATE - PSKLR) \\
&+ \left(T_c \left(\frac{1}{1+T_a S} \right) PSKLR - T_p \left((TCRATE - PSKLR) - PSKLR \right) \right) \cdot \left(\frac{1}{T_w} \right) \\
&+ PSKLR \cdot \left(\frac{1}{1+T_a \cdot S} \right)
\end{aligned} \tag{7.4.14}$$

By equating Equations (7.4.1) and (7.4.14) the (TCRATE/PSKLR) transfer function is

$$\boxed{\frac{TCRATE}{PSKLR} = \frac{1 + \left(T_a + T_i + \frac{T_c T_i}{T_w} \right) \cdot S}{(1+T_a S) \left(1 + \left(1 + \frac{T_p}{T_w} \right) \cdot T_i S + T_p T_i S^2 \right)}} \tag{7.4.15}$$

The derivation of the (SKIP/PSKLR) transfer function is as follows: -

From Equations (7.4.8) and (7.4.11)

$$\begin{aligned}
TRATE &= -\left(\frac{1}{T_p \cdot S}\right) \cdot \left(\frac{1}{T_i}\right) (SKIP + PSKLR \cdot T_p) \\
&+ \left(\left(\frac{T_c}{1+T_a S} \right) PSKLR - T_p S \left(\left(\frac{1}{T_p S} \right) (SKIP + PSKLR \cdot T_p) - PSKLR \cdot \left(\frac{1}{S} \right) \right) \right) \cdot \left(\frac{1}{T_w} \right) \\
&+ PSKLR \cdot \left(\frac{1}{1+T_a \cdot S} \right)
\end{aligned} \tag{7.4.16}$$

From Equations (7.4.1), (7.4.3) and (7.4.16) the transfer function of SKIP is the following.

$$\boxed{\frac{SKIP}{PSKLR} = T_p \left[\frac{1 + \left(T_a + T_i + \frac{T_c T_i}{T_w} \right) \cdot S}{(1+T_a S) \left(1 + \left(1 + \frac{T_p}{T_w} \right) \cdot T_i S + T_p T_i S^2 \right)} \right]} \tag{7.4.1.7}$$

APPENDIX 7.5

APSKPM *IThink* MODEL

The following figure shows the APSKPM simulation model using the *ithink* software.

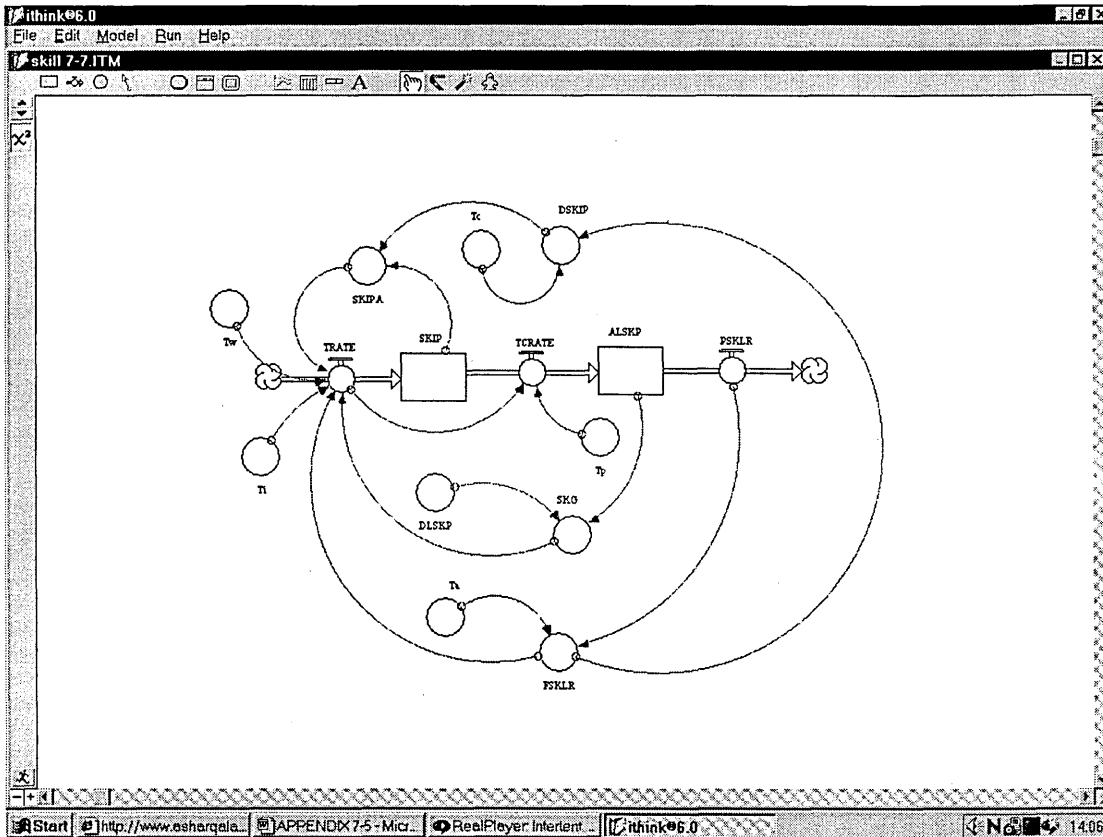

Figure 7.3.1: APSKPM model

The *ithink* simulation equations for the APSKIM model are:

$$\text{ALSKP}(t) = \text{ALSKP}(t - dt) + (\text{TCRATE} - \text{PSKLR}) * dt$$

$$\text{INIT ALSKP} = \text{DLSKP}$$

INFLOWS:

$$\text{TCRATE} = \text{SMTH1}(\text{TRATE}, T_p)$$

OUTFLOWS:

$$\text{PSKLR} = \text{STEP}(20, 1) + 100$$

$$\text{SKIP}(t) = \text{SKIP}(t - dt) + (\text{TRATE} - \text{TCRATE}) * dt$$

$$\text{INIT SKIP} = \text{FSKLR} * T_p$$

INFLOWS:

$$\text{TRATE} = (\text{SKG}/\text{Ti}) + \text{FSKLR} + (\text{SKIPA}/\text{Tw})$$

OUTFLOWS:

$$\text{TCRATE} = \text{SMTH1}(\text{TRATE}, \text{Tp})$$

$$\text{DLSKP} = 400$$

$$\text{DSKIP} = \text{FSKLR} * \text{Tc}$$

$$\text{FSKLR} = \text{SMTH1}(\text{PSKLR}, \text{Ta})$$

$$\text{SKG} = \text{DLSKP} - \text{ALSKP}$$

$$\text{SKIPA} = \text{DSKIP} - \text{SKIP}$$

$$\text{Ta} = 4$$

$$\text{Tc} = 4$$

$$\text{Ti} = 4$$

$$\text{Tp} = 4$$

$$\text{Tw} = 4$$