

# DESIGN OF A FINGER LIME LOADING SYSTEM

A Senior Project submitted to  
the faculty of California Polytechnic State University,  
San Luis Obispo

In partial fulfillment  
of the requirements for the Degree of  
Bachelor of Science in Manufacturing Engineering

By  
Joel Hitchen  
June 2017

ABSTRACT  
DESIGN OF A FINGER LIME LOADING SYSTEM  
Joel Hitchen

**Abstract**

Automation for post harvest processing of finger limes is required to meet demand for the new citrus fruit being introduced to United States of America food and agriculture market. As labor wages rise, and demand climbs for finger lime product a creative solution is needed to eliminate human labor and reduce the manual input needed to process finger limes. Building on an already successful processing tool, a semi-automated loading system was designed and implemented to overcome the problem.

## **ACKNOWLEDGMENTS**

Jim Shanley – President of Shanley Farms  
Dr. Xuan Wang – IME Technical Advisor  
John Penvenne – Cal Poly BRAE Faculty  
Jim & Kathy Hitchen – Excellent parents

## TABLE OF CONTENTS

	Page
Abstract .....	2
List of Figures .....	5
Introduction .....	6
Literature Reviews .....	7
Background .....	7
Design .....	8
Methodology .....	16
Results .....	16
Conclusion .....	17
Bibliography .....	18



## LIST OF FIGURES

	Page
Figure 1 – Shanley Farm finger lime section view .....	6
Figure 2 – Processing machine currently in operation .....	7
Figure 3 – Finger lime sample placed on processing belt .....	8
Figure 4 – System Drawing and Subsystem breakdown .....	9
Figure 5 – Hand sketch of loader concept .....	10
Figure 6 – Hand sketch of end-of-line loader concept .....	10
Figure 7 – Sketch to prototype demonstration .....	11
Figure 8 – 3D / 2D CAD model compared to physical prototype .....	12
Figure 9 – Screen shot of a video demonstrating the lime sorting capabilities .....	13
Figure 10 – Drop testing to understand the C&O device .....	14
Figure 11 – Fitment test to processing belt .....	14
Figure 12 – Gen 2 (front) compared to Gen 1 (back) .....	15
Figure 13 – Gen 2 C&O with limes in position to be processed .....	15
Figure 14 – Sample of population shown with 30 limes .....	16

## 1. Introduction

The subject of this report is the design and implementation of semi-automated finger lime loading system that will integrate with an existing processing machine.



**Figure 1 – Shanley Farm finger lime section view.**

Introduction of automation systems has become widely adopted as a business tool to stay competitive. Agriculture traditionally has been highly labor dependent with limited application of automation equipment (Suprem, 2012). With advances in technology and an ever-growing global demand of food, automation is one effective way to increase production throughput of many agriculture systems (Suprem, 2012). When produce processing equipment can be automated, repetitive human labor is minimized. This allows human input to be focused on more meaningful tasks that are not suited for automation. Shanley Farms of Morro Bay, California is facing a shortage on production capacity of a unique citrus fruit known as the finger lime. Shanley Farms is the leading grower of finger limes in the USA and is ramping up for new distribution of the finger lime product. The projections for sales of the finger lime produce are outside of the current capacity of Shanley Farms. There is a processing machine currently in operation but this machine requires manual loading of finger limes as seen in Figure 1 and Figure 3. To meet growing demand for the finger lime product and boost profit margins, the processing of this rare fruit needs to be further automated. Currently three employees are needed to operate and load the machine, which is a large non-value adding cost for the finger lime produce. Shanley Farms is seeking a creative design solution that can singulate, orient, and load finger limes into the machine. A loading system would reduce the labor needed to operate the processing equipment, ultimately making the product more profitable and ready to scale sales volume.

## 2. Literature Review

To accomplish the objectives, a study of existing conveyance methods and automation standards was conducted. Due to the new introduction of the Finger Lime into US markets and mass consumption, there was no literature directly concerning the processing of Finger Limes. To learn useful information, most of the literature and background information was collected by studying similarly shaped produce items such as carrots, peppers, and green beans. There are several mechanical conveyor systems used for food processing, however, the most ideal method of mechanical conveyors for agriculture products is vibratory conveyance (Keppler, 2016). Vibratory conveyance allows for produce to have a rather large variance in shape and size but still be effective at moving from one place to another. In contrast to a, belt fed systems the vibratory system will also allow fruit to accumulate when the machine is loaded without causing damage to the produce before processing. Vibratory conveyance also was found to prevent bridging and clogging of fruit (Gan-Mor, 1983).

## 3. Background

The focus of this project will be the conveyance and sorting of finger limes from a bulk hopper and placing them precisely and accurately on the conveyor belt for processing. To insure every part of this complex sub-system is given equal attention, the report will be broken out into two sections as detailed below. The machine shown in Figure 1 is currently in operation, it functions well and is producing product for market. There are three more machines of similar function being produced to meet early demand for the product. Upwards of 25 machines like this are desired by the farm owner. Should the farm scale to 25 machines, manual labor to load the machines would create a large burden on the company's profit margins due to high labor costs. Shanley farms is interested in the subsystems called about above to semi-automate the process.

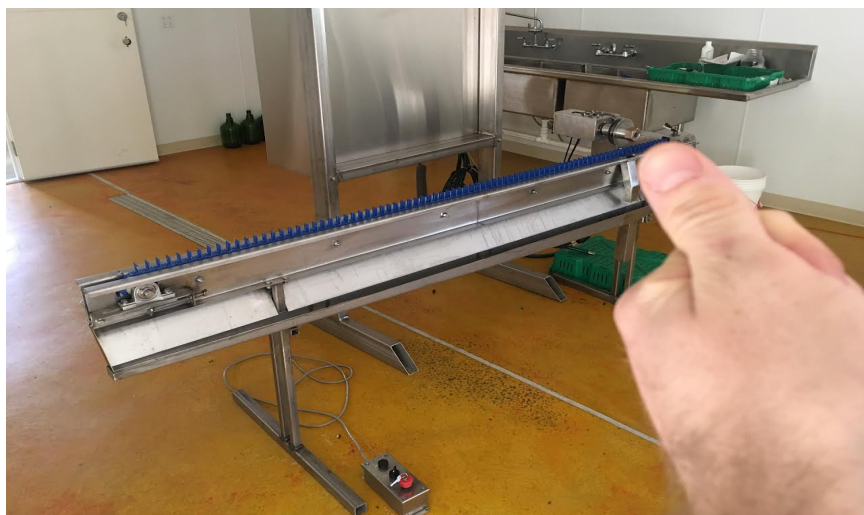

**Figure 2 – Processing machine currently in operation.**

## 1. Design

### 1.1. Design Objectives

Design objectives early in the project were agreed upon by Shanley farms and are listed below. These objectives guided the design to meet the requirements but not be bogged down with unneeded features and design considerations.

#### Objectives:

- 1) Design a hopper with capacity of 2.0 cubic feet of limes.
- 2) Sort, orient, and organize limes in single file line.
- 3) Load onto belt with 99% accuracy or better.
- 4) Center limes on processing belt to maximize yield.

### 1.2. Current State

Shanley Farms is currently operational with their processing equipment shown in Figure 1 and Figure 2. Figure 2 shows the belt direction of motion and ideal lime placement on processing belt. a photograph of the current machine that is operated by Shanley Farms. In the initial condition before this project was started, each finger lime is hand placed on the conveyor belt in the shown orientation in Figure 3.

### 1.3. Design Constraints

Design constraints that exist are as follows:

- Belt moves at 1 inch / 3 seconds, this is fixed and not up for change.
- Conveyor belt is fixed to a 1 inch spacing between slots and a 1-inch cube to fit finger limes into.
- All parts that contact food must be easy to sanitize, and service.
- All parts should be robust and ready for daily production use.

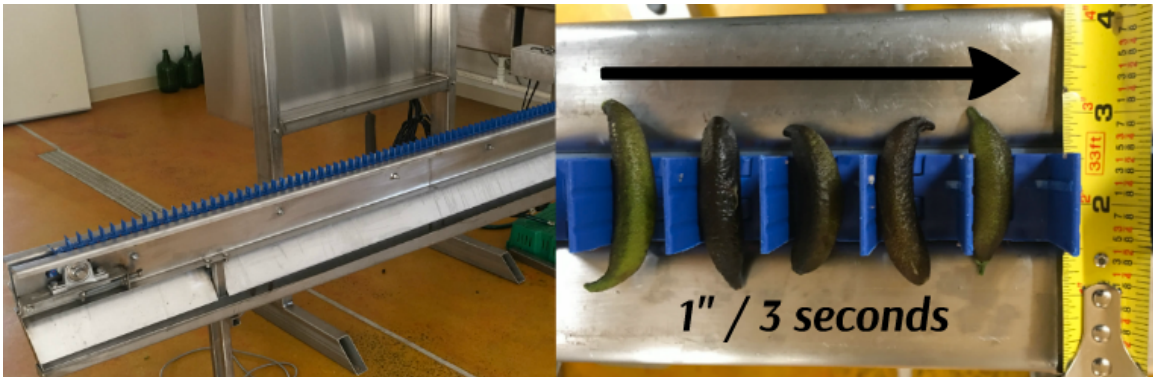

Figure 3 – Finger lime sample placed on processing belt.

### 1.3. Abandoned Design Concepts

During the projects design and test phase, two concepts were ruled out from further development due to complexity, and assumptions proving to be false. The two rejected concepts are as follows.

#### 1.3.1 Side-of-line Loader (3 subsystems)

This design concept was rejected due to the failed assumption that limes would slide down chute with the gravity alone. This assumption proved to be false with the stainless steel we attempted to use. The coefficient of static and kinetic friction proved to be variable depending on the lime and was not reliable.

The second reason the side-of-line loader design concept was rejected was due to the complexity of the subsystem. Shown in Figure 3, subsystem 2 would be used to control the flow of finger limes one by one into the belt landing zone. This subsystem would rely on a constant velocity delivery of the finger lime so that an optical sensor can measure the beam break and then give the length of a lime to subsystem 3. Then once the lime arrived onto the processing belt, subsystem 3 would move a linear servo with a paddle attached to adjust and center the finger lime to maximize yield. This proved to be overly complex for the desired result.

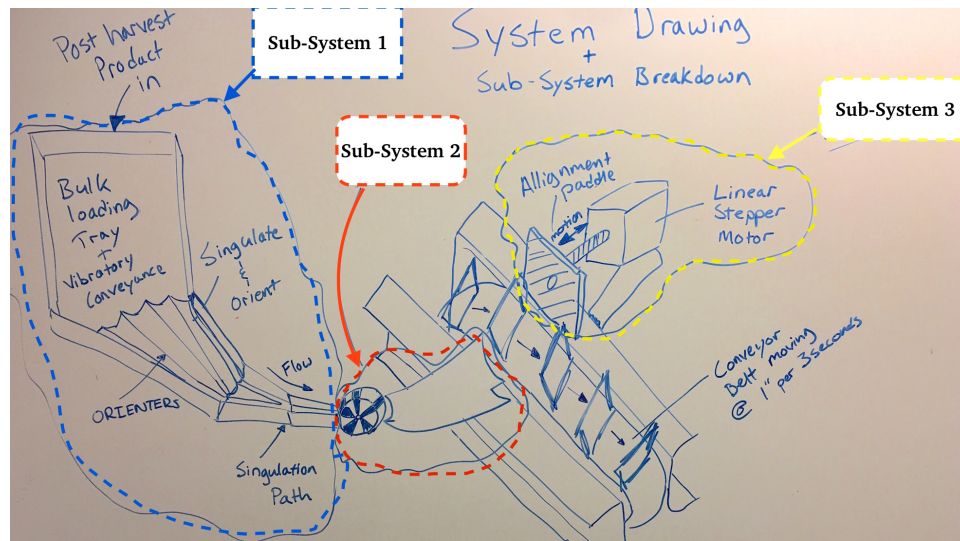
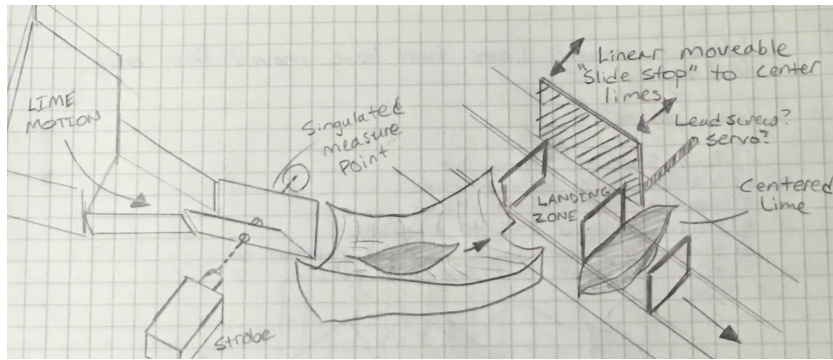

Figure 4 – System Drawing and Subsystem breakdown.

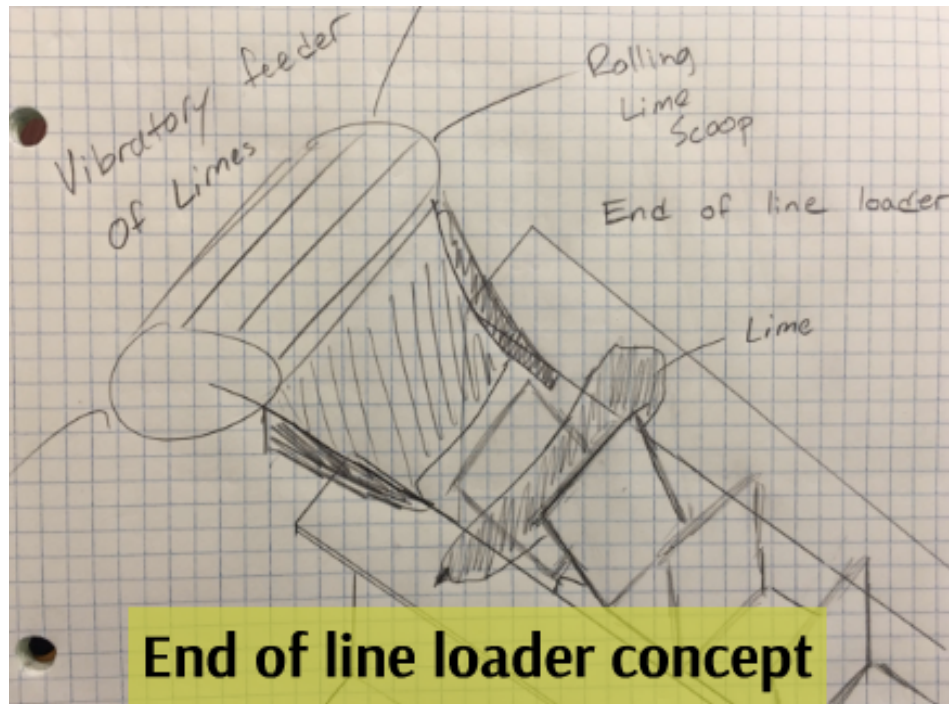



**Figure 5 – Hand sketch of loader concept.**

### 1.3.2 End-of-line loader (1 subsystem)

The end-of-line loader focused on an interesting space on the processing belt where the paddles returned to the top side of the machine. This concept was built on an assumption that if one finger lime was delivered to the spot where the belt wraps around, the lime will shift to center and then be perfectly located on the belt. This assumption proved to be false as there was a favoring of shorter limes for centering. The belt did not correct the orientation of most limes but rather just cycled them around which often led to the finger lime falling from the belt.



**Figure 6 – Hand sketch of end-of-line loader concept.**

## 1.4. Selected Design Concept (Two subsystems)

The selected design was chosen due to the least moving parts and lowest cost to implement while still being effective and meeting the design objectives. The winning design was broken into two subsystems to manage them easier. Once each concept was proven successful, a design for manufacturing (DFM) evaluation was completed to optimize function and minimize production time, and difficulty.

Underlying assumptions for this design are that the limes will be pre-qualified in a packing plant for minimum length and width dimensions.

Subsystem #1: Manage ~2.0 cubic feet of pre-sized and qualified limes, sort, singulate, and deliver one lime at a time into processing belt.

Subsystem #2: Orient, control degrees of freedom, and manage lime arrival onto belt. Limes must be centered on belt to maximize yield.

Cost for the chosen system to prototype is around \$500.00 including materials and labor. Shanley Farms agrees that the cost to experiment is negligibly small in the scope of delivering the systems. The total cost of this selected system would be approximately \$750.00-\$1000 per unit (2 subsystems) after shop time, CNC machine time, and labor.

### 1.4.1 Subsystem #1

The first subsystem in this design will be conveyance and sorting of the finger limes after they are loaded with approximately 2 cubic feet of finger lime product. The finger limes are assumed to be tangled and randomly oriented in this bulk loading tray after being dumped out of harvesting bins. After bulk loading, the finger limes are moved into a single file line so they can be dispatched to the processing belt. 2-D and 3-D design models are shown below in Figure 6. During testing, it was discovered that the center flange which acts as an aperture to limit flow, was removed due to negative impact.

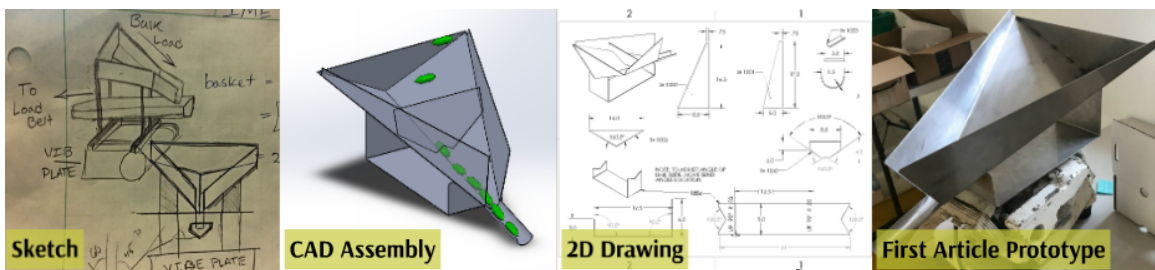
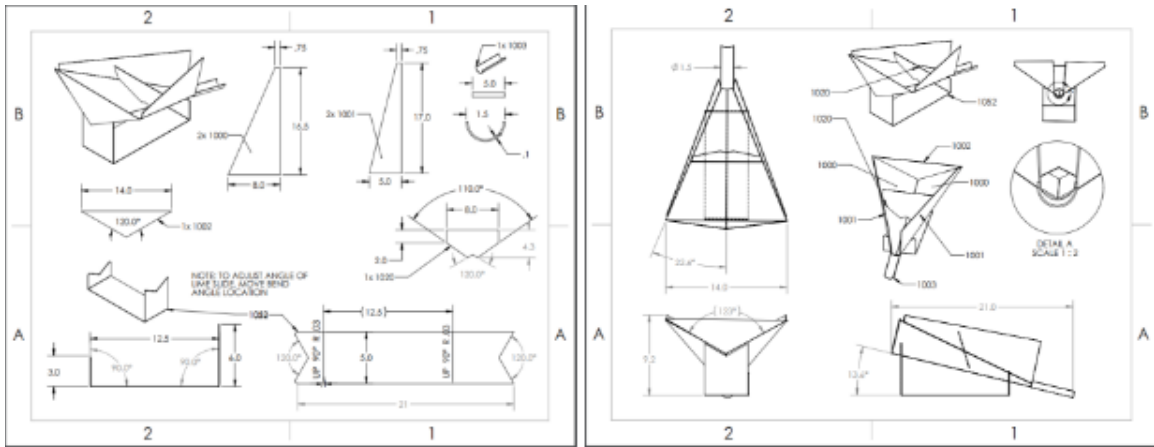
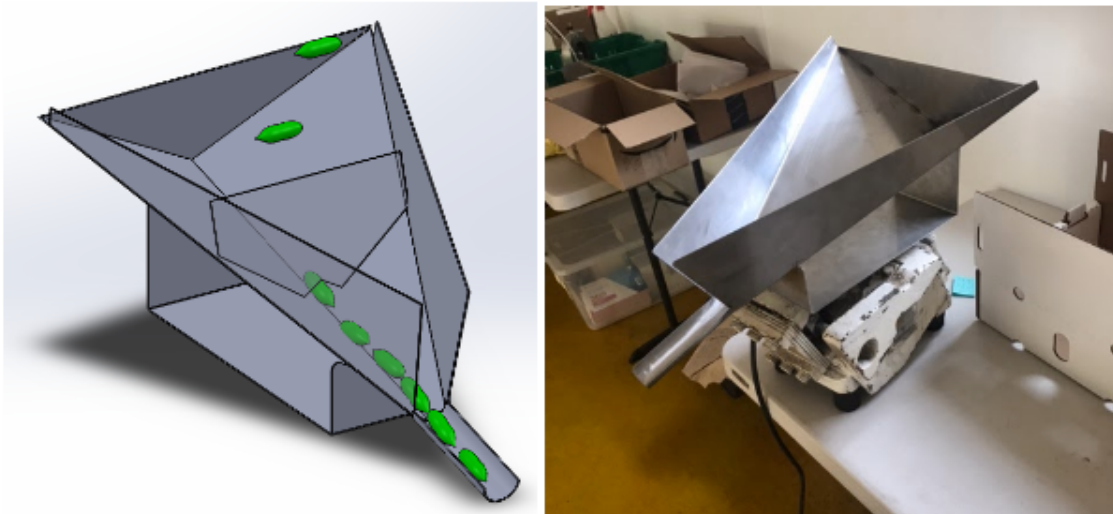

Figure 7 – Sketch to prototype demonstration.



**Note: Physical part has middle flange removed. After testing, it proved counter productive.**



**Figure 8 – 3D / 2D CAD model compared to physical prototype.**



In the screen shot shown in Figure 7, the left image is Time=Initial when a clump of limes is at the top of the slide. The screenshot on the right side is Time = 15 seconds when the limes started to singulate and move. Video will be included with final presentation.



**Figure 9 – Screen shot of a video demonstrating the lime sorting capabilities.**

### 1.4.2 Subsystem #2

The purpose of this system is to orient, place, and control lime arrival onto the belt to be properly processed. This is a “catch and orient” device (C&O) I designed and 3D printed. The device restricts the lime about 4 of the 6 degrees of freedom which helps with alignment onto the processing belt. The device works by allowing clearance of the belt, while the large aperture catches limes as they are delivered by 1<sup>st</sup> subsystem.

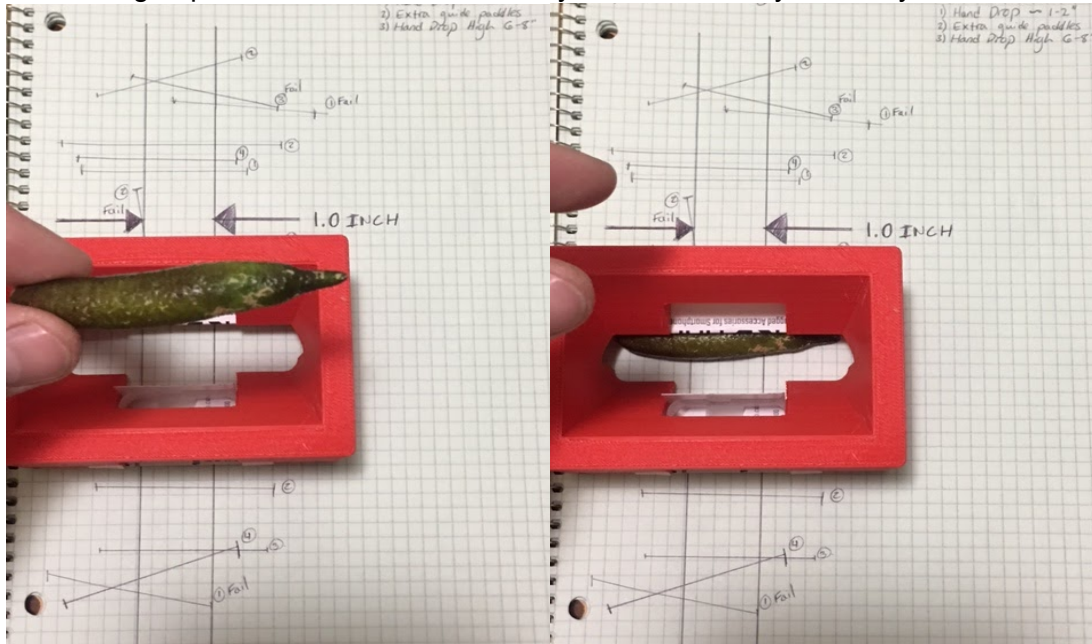

**Figure 10 – Drop testing to understand the C&O device.**

The 1st iteration part (pictured above and below) proved valid for the right size lime, but was not successful with smaller limes. A 2nd iteration was made to fit smaller, more common limes.

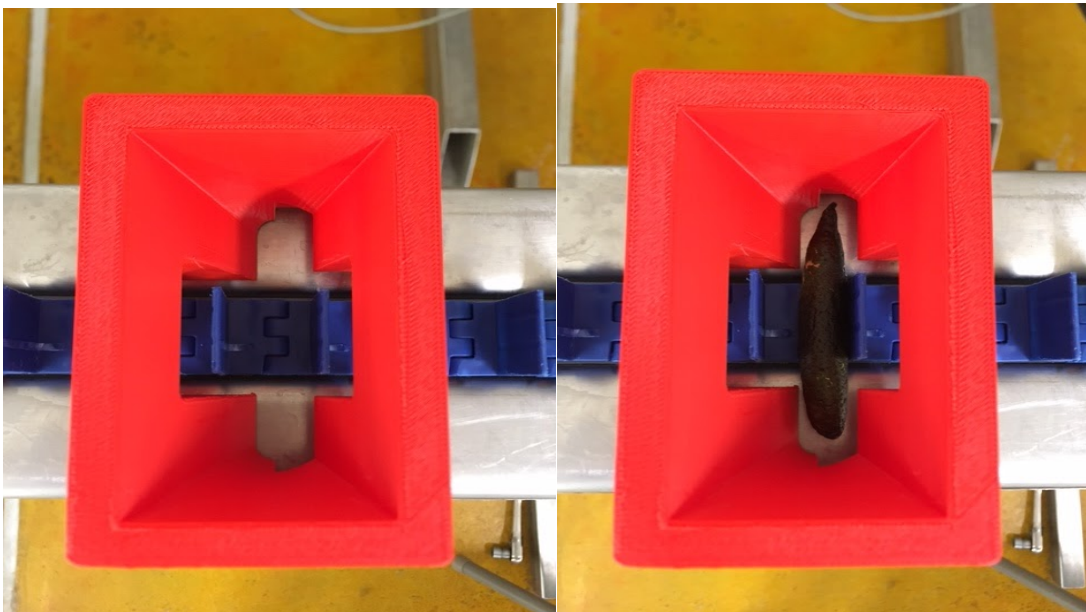

**Figure 11 – Fitment test to processing belt.**

The design was modified to be less bulky, and better sized to a 2.2inch lime which is the most common lime being processed. The pass-thru slot to clear the belt flanges was tightening up to reduce error as pictured below. Note: Larger red part in back is 1st iteration, smaller part in front of the picture below is 2nd iteration.

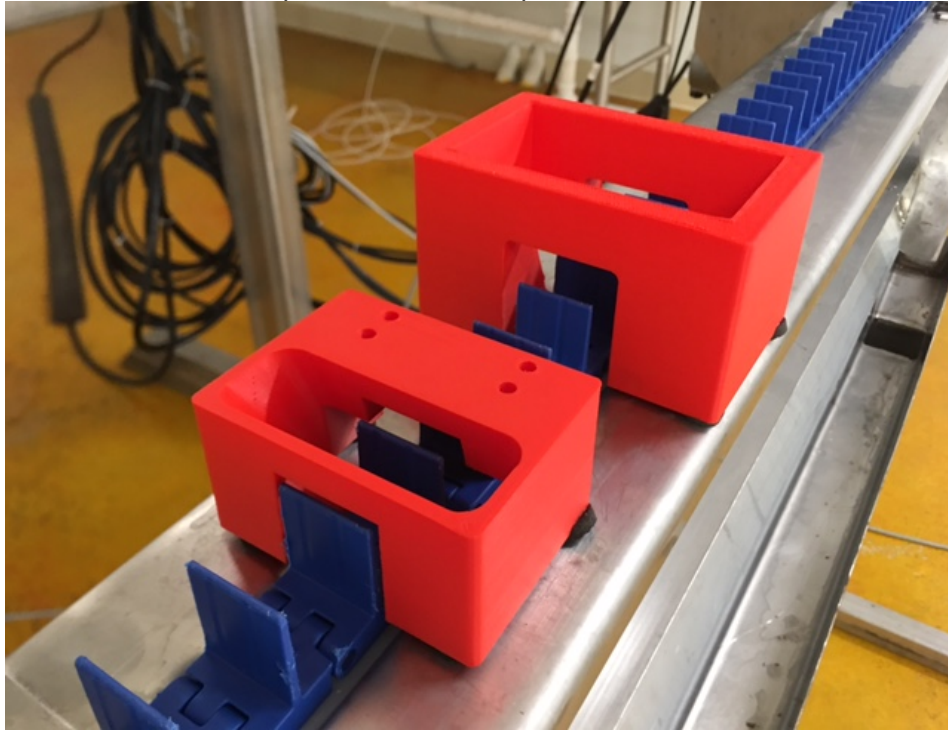

**Figure 12 – Gen 2 (front) compared to Gen 1 (back).**

Below are 3 limes stacked into the 2nd iteration part. This inspired the 3rd part which is currently being designed. Vibratory motion will be used to keep Finger Limes from becoming wedged into the loading device and will clear jams as they happen.

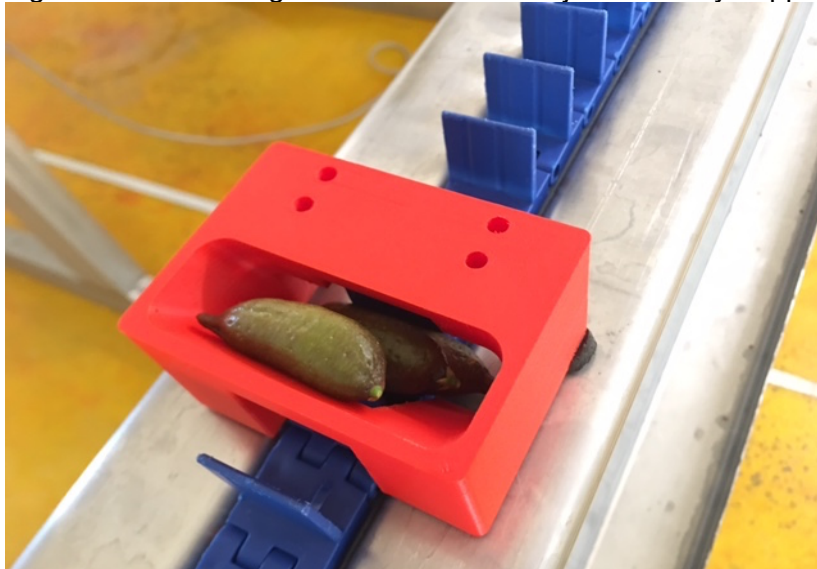

**Figure 13 – Gen 2 C&O with limes in position to be processed.**



## 5. Methods

To ensure designs of equipment for loading finger limes can handle the wide range of the limes, a random sampling of 30 limes was pulled from a random harvest batch on March, 2<sup>nd</sup> 2017, and studied to see the range of length, girth, and shape. The sampled limes are pictured below in Figure 6, and Figure 7 and provide a good visual understanding of how the finger limes vary. Further sampling and study will be complete in the coming weeks to construct histograms and understand variance in the limes. Shanley Farms believe there is not a normal distribution curve associated with the limes since their size varies greatly with the time of harvest. Further statistical tests will be conducted to decided upon ideal singulation methods. Some of the designs proposed for prototype have a chute that will deliver finger limes to the processing belt. With statistical data, better selection of materials can be made.



**Figure 14 – Sample of population shown with 30 limes.**

To test the design, the two sub-systems were prototyped individually with physical and virtual prototypes. For sub-system 1, the vibratory plate was purchased used from an agriculture fabrications shop in Santa Maria. The design for sub-system 2 involved a 3D print to prove out the design. Final manufacturing will be made out of CNC machined Delrin.

Physical prototypes proved out to be our best method of testing the products. Pictures and video were recorded of different situations. Theory and assumptions gave way to field testing and it was clear which designs failed and which design was a viable option.

## 6. Results

Subsystem #1 - Successfully accomplishes design objectives to manage bulk loading, deliver one-by-one in controlled pattern.

Subsystem #2 - Keep testing, and revising part design. Confident that desired result is plausible. Then design for manufacturing after concept validated.

## 7. Conclusions

Due to the success of the selected design, and promising results in subsystem 2, the project is worth pursuing to completion. The impacts of scale will be minimized and the business will have the flexibility to ramp and meet demand without impact on employees.

### 7.1. Ethical Impacts

- Upholding FDA and Food Processing standards when selecting materials and designing.
- Prevent biological issues from harming customers.

### 7.2. Societal Impacts

- Possible new job opportunities to meet demand.
- Local Commerce and tax revenue generation.
- New crop introduced to local agriculture and market generation.
- Lime skin peels that are not used for human consumption are being studied for the types of oils found in pores.

### 7.3. Organization Impacts

- Projected to be minimal.
- No existing positions are likely to be terminated due to automation.
- New product sales potentially lead to more job opportunities.

### 7.4. Environmental Impacts

- Machine production uses metal fabrication, CNC Delrin, PLC automation equipment.
- Possible increase of transit, processing, pre-qualifying, washing, etc. as volume increase.

#### Proposed design:

- 1 operator can operate 4 different machines to perform both load management and processed fruit management.

#### No automated loader:

- ~ = 25 employees @ \$15.00 with 40hr week = +/- \$15,000.00 labor.
- Monthly incurred cost of new hires: ~ = \$60,000.00
- 6 Month Labor Expense: ~ = \$360,000.00
- Assumption of +20% to overhead on top of new staff costs.

#### New semi-automated loader:

- New automated loader + existing system < \$10,000 (One time cost per machine)
- 25 machines @ \$7,500.00 per each machine ~ = \$187,500.00

All objectives laid out in the project are plausible and can likely be met with continuation of the design. Due to the short time commitment of this project, not all objectives were able to be addressed such as achieving 99% accuracy. Since the final design tests will conclude after the scope of this class, speculation will not be included with this document. The project was a great learning experience

for learning how to design bigger systems and focusing on the design of function with less regard to form. Much was learned about the importance of testing early and failing often so that innovation can take place.

### WORKS CITED

- Blasco, J., S. Cubero, J. Gomez-Sanchis, P. Mira, and E. Molto. "Development of a Machine for the Automatic Sorting of Pomegranate (*Punica Granatum*) Arils Based on Computer Vision." *Journal of Food Engineering* 34th ser. 90.27 (2008): 1-8. Engineering Village. Web. 3 Mar. 2017.
- Costa, Corrado, and Francesca Antonucci. "Shape Analysis of Agricultural Products: A Review of Recent Research Advances and Potential Application to Computer Vision." *Rev. of Food Bioprocess Technol.* Springer Science+Business Media, LLC (2011): 1-20. Print.
- Jarimopas, Bundit, Nuttapong Ruttanadat, and Anupun Terdwongworakul. "An Automatic Trimming Machine for Young Coconut Fruit." *Elsevier* 175th ser. 103.167 (2009): 1-9. Science Direct. Web. 8 Mar. 2017.
- Keppler, S., S. Bakalis, C.E. Leadley, and P.J. Fryer. "Processing of Barley Grains in a Continuous Vibrating Conveyor." *Journal of Food Engineering* 123rd ser. 187.114 (2016): 1-10. Compendex. Web. 5 Mar. 2017.
- Mahalik, Nitaigour P. *Processing and Packaging Automation Systems: A Review.* Tech. N.p.: Springer Science+Business Media, LLC, 2009. Engineering Village. Web.)
- Masood, S. H., B. Abbas, E. Shayan, and A. Kara. "An Investigation into Design and Manufacturing of Mechanical Conveyors Systems for Food Processing." *Engineering Village.* Cal Poly, 23 June 2004. Web. 1 Mar. 2017.

Nambiar, Arun N., and Nitaigour P. Mahalik. "Trends in Food Packaging and Manufacturing Systems and Technology." Trends in Food Science & Technology 128th ser. 21.117 (2010): 1-12. Compendex. Web. 8 Mar. 2017.

Patel, Krishna Kumar, A. Kar, S. N. Jha, and M. A. Khan. "Blasco, J., S. Cubero, J. Gomez-Sanchis, P. Mira, and E. Molto. "Development of a Machine for the Automatic Sorting of Pomegranate (Punica Granatum) Arils Based on Computer Vision." Journal of Food Engineering 34th Ser. 90.27 (2008): 1-8. Engineering Village. Web. 3 Mar. 2017." Engineering Village. Cal Poly, 9 Apr. 2017. Web. 3 Mar. 2017.

Suprem, Abhijit, Nitaigour Mahalik, and Kiseon Kim. "A Review on Application of Technology Systems, Standards and Interfaces for Agriculture and Food Sector." Computer Standards & Interfaces 364th ser. 35.355 (2012): 1-10. Compendex. Web. 8 Mar. 2017.

Thabet, Hassaan TH. H., and Mayasara A. Qasim. Proposed Industrial Concept for Automating a Food Production Process Using PLC. Proc. of Engineering ICECCPCE, Iraq, Mosul. 1-5. 18 Dec. 2013. Web. 5 Mar. 2017.