

Commercial Application of Sustainable Self-Consolidating Grout

A Senior Project

presented to

the Faculty of the Architectural Engineering

California Polytechnic State University, San Luis Obispo

In Partial Fulfillment

of the Requirements for the Degree

Bachelor of Science in Architectural Engineering

by

Adrian Saraf and Nick Knowles

December, 2017

© 2017 Adrian Saraf, Nick Knowles

Acknowledgements

We would like to give special thanks to the following individuals for contributing to the success of our research and the facilitation of our learning experience. The generosity of these individuals to share their time and resources is much appreciated and made possible the project that follows

Kurt Siggard | Concrete Association of California and Nevada
Arrangement of Sustainable Materials Donation

Bill Boughton | Lehigh Cement
GGBS Donation

Josh Patterson | Lehigh Cement
GGBS Donation

Doug Yeggy | Headwaters Inc.
Fly Ash Donation

Ron Jordan | Jordan Pumping
Job site visit to observe commercial pumping

Erik Geil | Air-Vol Block
CMU manufacturing plant tour

Nomenclature

- Blast Slag:** Obtained by quenching molten iron slag (a by-product of iron and steel-making) from a blast furnace in water or steam, to produce a glassy, granular product that is then dried and ground into a fine powder.
- Cement:** A powdery substance made with calcined lime and clay. It is mixed with water to form mortar or mixed with sand, gravel, and water to make concrete.
- Coarse Aggregate:** Rocks, crushed stone, or ore between 12.5 mm and 600 μm in diameter.
- Consolidation:** Term describing a grout's ability to fill all voids within the cells of CMU construction. This becomes more difficult to achieve with the installment of reinforcing rebar.
- Curing:** The process in which any cement based products are placed in temperature and moisture and temperature controlled locations in order for a proper chemical process to occur.
- Entombed:** Encased within the cells of a masonry wall filled with grout.
- Fine Aggregate:** Sands and other particles between 9.5 mm and 75 μm in diameter.
- Fly Ash:** A coal combustion product composed of fine particles that are driven out of the boiler with the flue gases.
- Grout:** A plastic mixture of cementitious materials, aggregates, and water, with or without admixtures, initially produced to pouring consistency without segregation of the constituents during placement.
- Hydration:** A chemical process activated by the combination of water and cement, resulting in a mixture that gradually solidifies and bond the various sized aggregate and other materials within the mixture.
- Lift:** The height of grout to be poured in one pass, several lifts may be required to fill the cells of a completed masonry wall.

Lime:	A white caustic alkaline substance consisting of calcium oxide, which is obtained by heating limestone and which combines with water with the production of much heat; quicklime.
Limestone:	A sedimentary rock, composed mainly of skeletal fragments of marine organisms such as coral, forams and molluscs.
Masonry:	The building of structures from individual units (no larger than what a person can handle by hand, such as a brick), which are often laid in and bound together by mortar.
Pour:	The height of masonry to be filled with grout prior to any additional masonry construction. (Can be comprised of multiple lifts)
Pozzolan:	A broad class of siliceous or siliceous and aluminous materials which, in themselves, possess little or no cementitious value but which will, in finely divided form and in the presence of water, react chemically with calcium hydroxide at ordinary temperature to form compounds possessing cementitious properties.
Slump:	A measurement of the grout's consistency and workability.
Slump Flow:	A measurement of the self-consolidating grout's flowability.

Purpose

The purpose of this senior project is to perform ASTM (American Society of Testing and Materials) tests that would mimic commercial construction on a sustainable self-consolidating grout mix that utilizes waste products and investigate its ability to flow, structural properties, and real world applications. The goal is to become familiar with standard test methods and observe commercial construction techniques to gain experience about issues in subject matter outside of engineering curriculum.

Introduction

Masonry grout is a mixture of water, cement, and aggregates. Grout fills concrete masonry unit (CMU) voids, known as cells, and hardens thus adhering the steel rebar to the masonry. Now the rebar and CMU can act as one unit, transferring stresses back and forth. The masonry cells are limited in size and the inclusion of rebar often causes congestion (see Figure 1).



Figure 1: Rebar Congestion in CMU cell

This congestion requires the grout to flow throughout the CMU cells and get between all of the rebar. A measure of the ability to flow is the water to cement ratio. The water to cement ratio is measured by a slump test. Typical slump for grout is 8-11 inches (see Figure 4A)

In order for a specific mix of grout to be commercially used in buildings, the mix must be tested through standard test methods to ensure there is a proper ratio of aggregates, cement, and water to reach standard design strengths. ASTM provides specific procedures on how to prepare, handle, and test materials. Two examples of ASTM standards are as follows.

- ASTM C476 – Standard Specification for Grout for Masonry
- ASTM C1019 – Standard Test Method for Sampling and Testing Grout

For grout, the ASTM provides steps to ensure strength, but also that the grout is fluid enough to flow through concrete masonry unit cells and between rebar. Though grout has flow characteristics, there are still voids and trapped air.

In order to eliminate voids, grout that is placed inside CMU cells must be mechanically vibrated to consolidate between all of the rebar. Then the pumpers must wait for the water in the grout to be absorbed into the CMU block. This absorption causes more voids and the grout must be vibrated again. This second vibration process is known as reconsolidation.

Grout that does not need to be mechanically vibrated and reconsolidated is known as self-consolidating grout. Today, self-consolidating grouts achieve their properties with the addition of chemical admixtures. These chemical admixtures can reduce the viscosity of the mix without increasing the water to cement ratio. While self-consolidating grout with chemical admixtures is beneficial, using it requires skilled laborers, careful temperature and humidity control, and can be difficult to produce on the construction site (Lanier 2003).

For our *sustainable* self-consolidating grout, rather than using chemical admixtures to reduce the viscosity of the mix, a large portion of the Portland cement will be replaced with fly ash and blast slag. While Portland cement is cheap and abundant, the environmental impact of mining, manufacturing, and transporting is great. For the production of cement, a mixture of sand and limestone must be heated to 2700 °F and machines must crush and grind the mix into a fine powder. Considering the high demand for cement worldwide, reducing a percentage of its usage could have huge environmental impact (Baltimore and Mwangi 2009).

Currently, testing has shown that replacing 20% to 50% of the volume of Portland cement in grout with Class F Fly Ash met the minimum code strength requirement of 2000 psi within the standard construction time duration of 28 days (Baltimore and Mwangi 2009). This shows that supplementing Portland cement with waste products can be a viable

solution to making a more sustainable mix that may have other benefits such as strength and fluidity. But simply replacing the cement is not enough to increase flow. Research by Brigham Young University has shown this (Fonseca 2012). In order to increase the flow properties, ground granulated blast slag (GGBS) was also added.

Self-consolidating grout is a relatively new concept and there seems to be potential for improvement. In this senior project we will be investigating grout mixes with different percentages of Portland cement replaced with waste products to see if there are benefits in mix workability while maintaining standard design strength. We will perform repeatability tests to ensure consistency in results of future tests that may be done on similar mixes and investigate issues for testing under commercial conditions.

Background

Traditional grout consists of coarse and fine aggregates, Portland cement, water, and lime. ASTM C404 defines aggregates as coarse if 100% of the aggregate passes the 12.5 mm (1/2 inch) sieve and no more than 5% (10% for manufactured sand) passes the 600 μm (No. 30) sieve. ASTM C404 defines aggregates as fine if 100% of the aggregate passes the 9.5 mm (3/8 inch) sieve and no more than 5% (10% for manufactured sand) passes the 75 μm (No. 200) sieve.



Figure 2: Grout Pumped into Masonry Wall

Portland cement is a fine powder made up of limestone and clay minerals that are heated in a kiln. When the cement reacts with water, it goes through a chemical process called “hydration” that creates a crystalline structure and bonds the aggregate. This process is quick at first, with the grout reaching 70% of its strength after 28 days, and slows down to reaching 90% strength after 1 year, thus it gives the appearance of strengthening the grout over time. Small amounts of lime are added to increase workability, increase water resistance, and minimized cracking due to shrinkage.

Once a CMU wall is laid, pumpers must place the grout in *pours* and *lifts*. Due to the height of grout that is to be placed, vibration is required intermittently to make sure the grout gets fully consolidated between all of the spaces and rebar. Multiple lifts and vibrations take time and slow down construction. A pour is the amount of grout that is to be poured before additional CMU wall is to be built. A lift is the amount of grout to be poured and allowed to set a little before the next lift (“Grout Pours and Lifts” 1999).

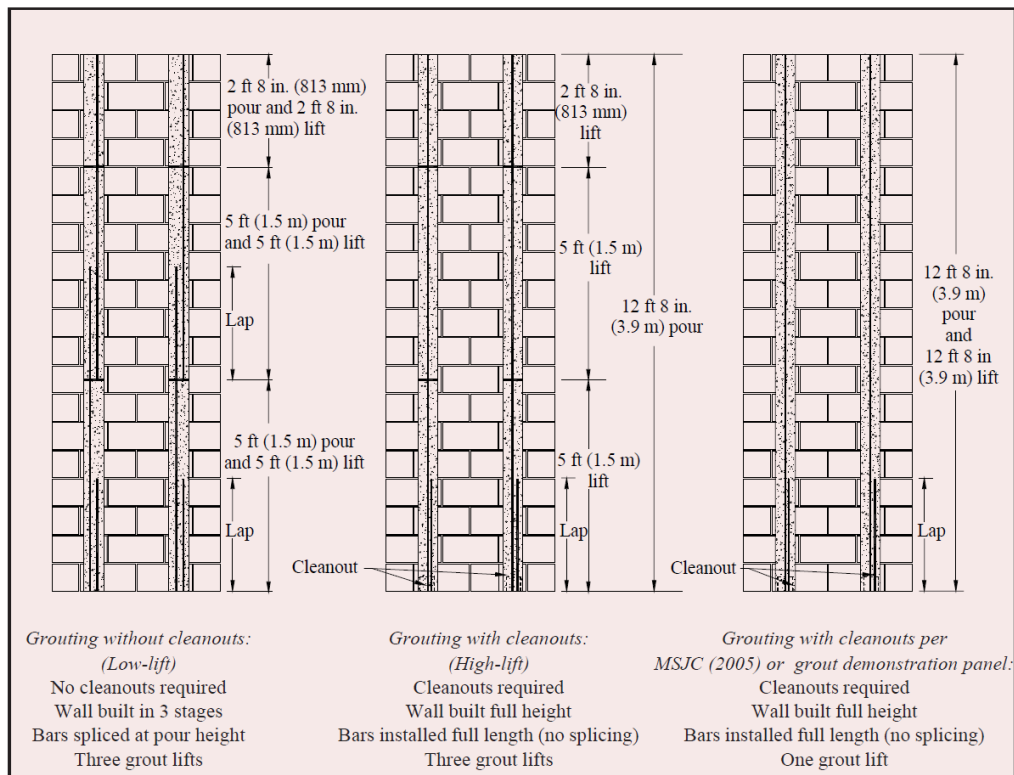

Figure 3: Grout Pour and Lift

Cite: NCMA TEK Note 3-2A

Making a mix that can be poured all at once and doesn't need to be vibrated would be very beneficial by speeding up the construction time. Such a mix can be achieved by replacing a portion of Portland cement with fly ash and blast slag.

Fly ash is a waste product of burning fossil fuels and can be a sustainable and environmentally friendly supplement to Portland cement. Fly ash is a pozzolan that induces a pozzolanic reaction with Portland cement. The reaction converts the silica in the fly ash into calcium silicate which has good cementing properties (Dunstan 2011). In a fully grouted CMU wall, grout makes up about half the volume so reducing a percentage of Portland cement can add up on large construction projects (Baltimore and Mwangi 2009). In addition to being a waste product, fly ash particles are spherical and act like ball

bearings to increase the workability (decrease viscosity) of the grout without having to add more water.

Ground Granulated Blast Slag is a waste product from steel and iron production where impurities and toxins from the ore remain on the molten surface. When cooled and ground up into fine particles, blast slag can supplement cement to slow the setting process to make the mix more workable for a longer period of time (“Ground Granulated Blast Furnace Slag in Concrete and its Advantages.” 2017). The blast slag is the impurities of the steel making process. It is difficult to control or predict the actual impurities. If there are any toxic impurities in the blast slag, the final assembly of grout is that the grout is entombed by the CMU. Thus any toxin is safely separated from society. It is noted that a masonry building can have a life cycle of over 100 years. This makes the use of GGBS as a grout material extremely sustainable.

Once a new mix of grout is made from different parts cement, fly ash, and blast slag, the grout must be tested to ensure proper strength as well as fluidity. In order for mixes to be tested for fluidity, a slump test and a slump flow test are necessary. Grout is poured into a cone with specific dimensions, and lifted up letting the grout flow out the bottom. Slump is measured from the top of the cone to the top of the mound of grout (see Figure 4A). Slump flow is measured by taking the diameter of the mound of grout in two directions 90 degrees to each other (see Figure 4B). Normal grout should have a slump between 8 and 11 inches, and self-consolidating grout a slump flow of 24 to 30 inches.

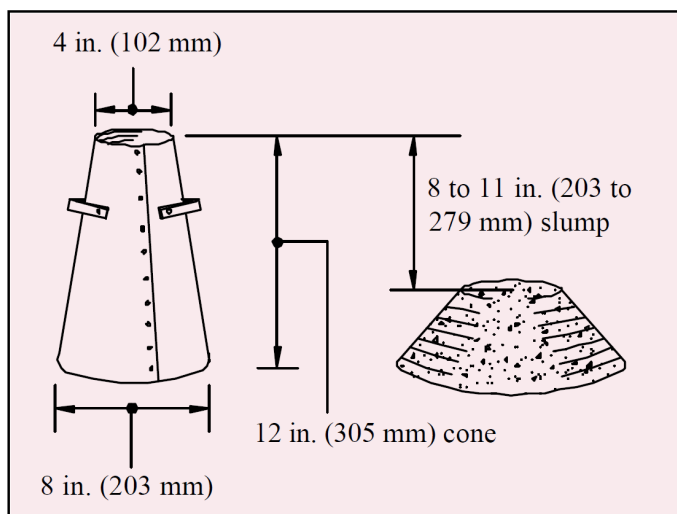

Figure 4A: Slump Test
Cite: NCMA TEK Note 18-8B

Figure 4B: Slump Flow Test

Testing Grout

There are three reasons as to why laboratory testing was necessary for this project. The first is to demonstrate repeatability. Repeatability means that test results can be recreated by anyone following the given procedure, which was achieved in this project by using the standard grout testing procedure and different methods of obtaining the grout test specimen and comparing the results to other lab results. The second reason is to further understand commercial application. Testing different methods of obtaining grout test specimen provides a better judgment of what could be the most efficient way to test grout at a larger, commercial scale. The third and final reason for the testing is to investigate a sustainable self-consolidating grout mix.

When testing, the universally accepted code for all building material is the ASTM standards which contains all testing procedures for building materials. The ASTM standards (ASTM C1019 for standard masonry grout and ASTM C1611 for self-consolidating grout) inform that testing grout mainly consists of two criteria: slump (or slump slow for self-consolidating grout) and compressive strength. Slump is measured to establish the grout's water content based on the type, and compressive strength is required for the structural integrity to any CMU wall that is filled with grout. This is important because all high seismic areas in California require CMU construction to be fully grouted.

Repeatability

This section will discuss three different methods of obtaining grout test specimen as specified by the ASTM standards as well as provide test results and compare them to previous data from another laboratory.

Compression Test Specimen - Pinwheel

This method requires the use of four CMU's organized in a "Pinwheel" orientation, leaving a 3-inch square void in the center for the grout to fill. A non-absorbent block is placed at the bottom of the void and the walls of the center void will be lined with damp paper towels as well as on top after the grout is poured into the void. An illustration of the method is shown below (see Figure 5).

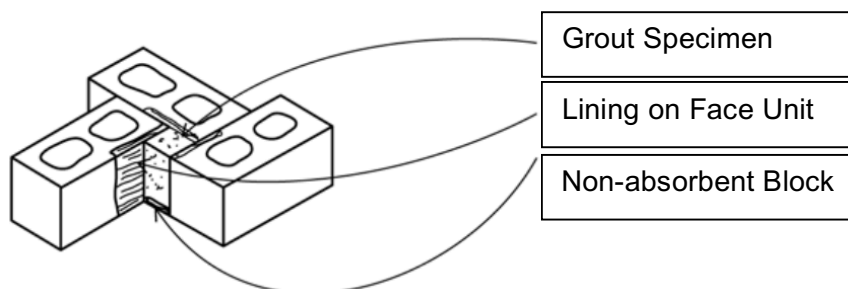

Figure 5: Masonry Pinwheel Specimen for Grout Compression Testing

Compression Test Specimen - Filled Then Cut CMU

This method is as straight-forward as it sounds, an empty CMU is filled with the grout to be tested. Then it will be cut into the desired 3x3x6 inch specimen to be tested. The ASTM standards show preference to the pinwheel, most likely for the control of size of specimen and the fact that cutting the grout will mean the coarse aggregate will be cut at the boundaries, potentially affecting strength tests. In addition to having to cut the specimen out, the top and bottom will need to be “capped” in order to make sure both ends are flat for testing. The flat surface will help assure a uniform pressure. An illustration of the capped specimen is shown below (see Figure 6).



Figure 6: Filled then Cut CMU Test Specimen

Note: all coarse aggregate along edges has been cut open.

Compression Test Specimen - Cardboard Grout Box

This method is by far the easiest to execute, all that is required is to assemble the boxes, fill with grout, and tape shut. It is also the most efficient, yielding four specimens per box versus one per pinwheel and two per CMU block. Unfortunately, this method has not been widely accepted by most, therefore testing was necessary to put the cardboard grout box in comparison with a separate studies' results on normal grout. An illustration of the grout box and specimen are shown on the next page (see Figure 7).



Figure 7: Masonry Grout Sample Box and Test Specimen

Test Results and Comparison of Standard Grout

The pinwheel method and cardboard grout box methods were tested to determine if the grout sample boxes would be reliable for testing at a commercial scale. The first test that was conducted was that of standard grout to insure that repeatability had been achieved in the laboratory setting. The results of our laboratory tests were then compared to another set of test data performed by a private lab that asked not to be identified.

The tables below provide the results of a 28-day compressive strength test of standard masonry grout for both pinwheel and cardboard box samples. Test results from the filled CMU cells method are not included because of issues with the capping process. The caps were not even, therefore unexpected concentrated stresses were administered during the tests, leaving the data unreliable.

Label	Type	Height (in)	Length (in)	Width (in)	Area (in ²)	Force (lbs)	fc (psi)
SG1	Pinwheel	6	2.875	2.875	7.766	19350	2492
SG2	Box	6.375	3.25	3.25	10.563	30100	2850
SG3	Box	6.25	3.125	3.25	10.156	27490	2707
SG4	Box	6.25	3.125	3.25	10.156	29200	2875
SG5	Box	6.375	3.125	3.125	9.766	28250	2893

Table 1: Standard Grout Compressive Strength Test - Saraf & Knowles

The first thing to notice is that all of the grout specimen passed the required 2000 psi 28-day compressive strength requirement for all masonry grout. Another observation is that the cardboard boxes out-performed the pinwheel method. In results provided by the other lab, the Pinwheel method averaged 4546 psi and the cardboard boxes averaged 3473 psi. These results are a flipped image of our lab test in terms of which method performed better.

The other lab's tests were using a premixed design where our lab tests had been mixed with individual components. The average slump of the other tests was ten inches, where our slump was just under eleven inches because we wanted to create an "upper bound" of water content in the mix. This additional water could potentially be the reason for the different results since the cardboard may have a higher absorption rate than the CMU. Nevertheless, these tests both showed that the cardboard grout sample boxes were able to achieve proper design strengths, therefore making the testing process more time efficient, especially at a commercial scale where hundreds of specimen could potentially be required. All remaining tests were completed with predominantly Cardboard Box grout specimen with at least one pinwheel specimen as both a control and also due to the fact that ASTM prefers the pinwheel method because it most accurately simulates the absorption rate grout will experience when poured into a masonry wall.

Test Results of Sustainable Self-Consolidating Grout

The next test consisted of a grout mix that replaced a large amount of the Portland cement with GGBS and Fly Ash. The goal of this test was to see if the 28-day compressive strength of the mix would achieve the required 2000 psi.

Label	Type	Height (in)	Length (in)	Width (in)	Area (in ²)	Force (lbs)	fc (psi)
NG1	Pinwheel	6	3	2.875	8.625	26000	3014
NG2	Box	6.25	3.375	3.25	10.969	32450	2958
NG3	Box	6.125	3.25	3.125	10.156	32700	3220
NG4	Box	6.25	3.25	3.25	10.563	33250	3148
NG5	Box	6.125	3.125	3.25	10.156	22600	2225

Table 2: S.C. Grout Compressive Strength Test - Saraf & Knowles

As shown in the table above, the sustainable mix, with a slump flow of 28 inches performed roughly ten percent better than the standard grout mix (see Table 1).

The next mix to be tested was exactly the same as the mix above, however a small percentage of a "grout enhancer" was added to the mix in attempt to achieve a larger

slump flow without changing the water content of the mix. The results are shown below in Table 3.

Label	Type	Height (in)	Length (in)	Width (in)	Area (in ²)	Force (lbs)	fc (psi)
G1	Pinwheel	6.125	2.875	3	8.625	20700	2400
G2	Box	6.375	3.25	3.125	10.156	25000	2462
G3	Box	6.25	3.125	3.25	10.156	25100	2471
G4	Box	6	3.125	3.25	9.906	27000	2726
G5	Box	5.875	3.125	3.25	10.156	26500	2609

Table 3: S.C. Grout Compressive Strength Test - Saraf & Knowles

The mix above did not perform as well as the original sustainable self-consolidating grout mix, however it still achieved the 28-day minimum requirement for compressive strength. The important thing to note about this test is that the mix resulted in a slump flow of 31 inches, which by ASTM C1611 is over the limit of 24 inches to 30 inches. The results above are expected to be slightly higher if the slump flow of the mix is kept to under 30 inches by reducing the water content. Despite the slight undervalue of strength, it is concluded that the sustainable self-consolidating grout mix without the “grout enhancer” had the best performance of initial 28-day strength.

Interdisciplinary

The intention of this final section is to take the newfound knowledge and experience of the above sections and apply them to a commercial scale. It is not feasible for two students to conduct a commercial size operation. In order to properly outline what a commercial test procedure would entail, we reached out to professionals in the construction industry to better understand what it means to build with masonry and grout.

To get a better understanding of the potential commercial benefits of self-consolidating concrete, we met with Ron Jordan at Jordan Pumping to watch how concrete is pumped and see the issues with regular concrete. Since regular concrete is not as fluid, it was difficult for the concrete to make its way through the pump from the truck to the formwork. Pumpers had to constantly monitor the concrete as it made its way through the hose to make sure it didn't get stuck and build up too much pressure. Pumpers had to turn off the pump, shake the hose, and repeatedly hit it with a hammer to unclog the concrete. With self-consolidating concrete, the concrete would flow more easily and eliminate these delays.

Another thing we learned from the site visit was the need for construction tolerances. When the concrete was being placed, the workers simply put their boot underneath the rebar to lift it off the ground before pouring the concrete. As engineers, we specify things like rebar placement, but it is important to keep in mind that construction workers may not be able to be as precise as what is put on paper.



Figure 8: Jordan Pumping Pouring Sidewalk

Conclusion

Grout is widely used all around the world, so any improvements to the pre-existing mixes can have a big impact worldwide. The sustainable self-consolidating grout mixes yielded a slump flow as opposed to the slump of the standard grout mix for

an easier and faster pouring process for the pumpers and masons during construction. The replacement of Portland cement with waste products would greatly reduce the carbon footprint of grout production. All of the sustainable self-consolidating mixes reached the required 28-day strength of 2000 psi and in some cases the mixes outperformed the standard grout mix. A sustainable self-consolidating grout mix that can utilize waste products, speed up construction time, and maintain structural integrity is very beneficial environmentally and economically. The compressive tests performed in this report demonstrate there is potential for a sustainable self-consolidating grout mix to be used for commercial construction.

References

- American Society for Testing and Materials (ASTM). "Standard Specification for Aggregates for Masonry Grout" C404-03, West Conshohocken, Pa.
- American Society for Testing and Materials (ASTM). "Standard Test Method for Slump Flow of Self-Consolidating Concrete" C1611, West Conshohocken, Pa.
- American Society for Testing and Materials (ASTM). "Standard Test Method for Sampling and Testing Grout" C1019, West Conshohocken, Pa.
- (Baltimore and Mwangi 2009) "Going Green with Concrete Masonry Grout ." Masonry Chronicles.
- (Dunstan 2011) "How Does Pozzolanic Reaction Make Concrete 'Green'?" *World of Coal Ash Conference*, 11 May 2011.
- (Fonseca 2012) "High Volume Fly Ash Masonry Grout", *STRUCTURE Magazine*, May 2012
- ("Ground Granulated Blast Furnace Slag in Concrete and its Advantages." 2017) *The Constructor*, <<https://theconstructor.org/concrete/ggbfs-concrete-advantages/15274/>> (May 2017).
- ("Grout Pours and Lifts" 1999) *Masonry Construction*, <http://www.masonryconstruction.com/how-to/grout-pours-and-lifts_o> (May 2017).
- "GROUTING CONCRETE MASONRY WALLS TEK 18-8B - ncma-br.org." (2005). *NCMA TEK*, Cinder & Concrete Block Corporation.
- "GROUTING CONCRETE MASONRY WALLS TEK 3-2A - ncma-br.org." (2005). *NCMA TEK*, Cinder & Concrete Block Corporation.

(Lanier 2003) "Interim Guidelines for the Use of Self-Consolidating Concrete in PCI
Member Plants ." PCI Journal.